

JPRS-JST-86-025

10 SEPTEMBER 1986

JAPAN REPORT  
SCIENCE AND TECHNOLOGY

**DTIC QUALITY INSPECTED 2**

**DISTRIBUTION STATEMENT A**

**Approved for public release;  
Distribution Unlimited**

**19980218 090**

FOREIGN BROADCAST INFORMATION SERVICE

#### NOTE

JPRS publications contain information primarily from foreign newspapers, periodicals and books, but also from news agency transmissions and broadcasts. Materials from foreign-language sources are translated; those from English-language sources are transcribed or reprinted, with the original phrasing and other characteristics retained.

Headlines, editorial reports, and material enclosed in brackets [] are supplied by JPRS. Processing indicators such as [Text] or [Excerpt] in the first line of each item, or following the last line of a brief, indicate how the original information was processed. Where no processing indicator is given, the information was summarized or extracted.

Unfamiliar names rendered phonetically or transliterated are enclosed in parentheses. Words or names preceded by a question mark and enclosed in parentheses were not clear in the original but have been supplied as appropriate in context. Other unattributed parenthetical notes within the body of an item originate with the source. Times within items are as given by source.

The contents of this publication in no way represent the policies, views or attitudes of the U.S. Government.

#### PROCUREMENT OF PUBLICATIONS

JPRS publications may be ordered from the National Technical Information Service, Springfield, Virginia 22161. In ordering, it is recommended that the JPRS number, title, date and author, if applicable, of publication be cited.

Current JPRS publications are announced in Government Reports Announcements issued semi-monthly by the National Technical Information Service, and are listed in the Monthly Catalog of U.S. Government Publications issued by the Superintendent of Documents, U.S. Government Printing Office, Washington, D.C. 20402.

Correspondence pertaining to matters other than procurement may be addressed to Joint Publications Research Service, 1000 North Glebe Road, Arlington, Virginia 22201.

10 SEPTEMBER 1986

## JAPAN REPORT SCIENCE AND TECHNOLOGY

### CONTENTS

#### AEROSPACE SCIENCES

First Japan Helicopter Show Held at Tokyo Heliport (AEROSPACE JAPAN, Jun 86) .....	1
Commercial Operation To Buy 42 Helicopters in FY86 (AEROSPACE JAPAN, Jun 86) .....	2
Fokker Zeros in on YS-11 Replacement Market (AEROSPACE JAPAN, Jun 86) .....	4
Memorandum on Development of Commuter Plane Signed With PRC (AEROSPACE JAPAN, Jun 86) .....	5
Construction of Kansai International Airport To Begin (AEROSPACE JAPAN, Jun 86) .....	6
MITI To Study Hypersonic Transport (JPE AVIATION REPORT-WEEKLY, 28 Jul 86) .....	7
NLA To Study Copter Rescue System (JPE AVIATION REPORT-WEEKLY, 28 Jul 86) .....	8
Japan, Indonesia Agree To Undertake Survey (JPE AVIATION REPORT-WEEKLY, 28 Jul 86) .....	9
MITI To Mull Measures To Promote Sales of 7J7, V2500 (JPE AVIATION REPORT-WEEKLY, 28 Jul 86) .....	11
Nikkeo-Boeing May Set Up Joint Ventures (JPE AVIATION REPORT-WEEKLY, 28 Jul 86) .....	12

KHI, Swiss Company Sign Agreement on Gas Turbines (JPE AVIATION REPORT-WEEKLY, 28 Jul 86) .....	13
NASDA Launches Research on Power Supply Systems (JPE AVIATION REPORT-WEEKLY, 28 Jul 86) .....	14
<b>NEW MATERIALS</b>	
Trends in R&D of New Metallic Materials Discussed (KOGYO ZAIRYO, Oct 85) .....	15
Present Status, Future Trends	15
Superconductive Material, by Yasuzo Tanaka	21
Super Heat-Resistant Materials, by Hiromitsu Tanaka	36
Hydrogen Storage Alloys, by Tsutomu Iwaki	51
Amorphous Alloys, by Yasuo Yamamoto	73
Shape Memory Alloys, by Toshio Honma	88
<b>NUCLEAR DEVELOPMENT</b>	
Nuclear Industry Activities Discussed (GENSHIRYOKU SANGYO SHIMBUN, 17 Jul 86) .....	100
Research on KWU-type PWR	100
Delegation Dispatched to Soviet Union	101
Chinese Tour Nuclear Fusion Facilities	102
Reverse Magnetic Field Pinch Device	103

/9986

AEROSPACE SCIENCES

FIRST JAPAN HELICOPTER SHOW HELD AT TOKYO HELIPOINT

Tokyo AEROSPACE JAPAN in English Jun 86 p 68

[Text]

The first Japan Helicopter Show was held May 9-11 at Tokyo Heliport under the auspices of All Japan Air Transport Service Association.

Beginning this year, the association has selected April 14 as the "Helicopter Day" in commemoration of the birth of Leonardo da Vinci. The helicopter show was held as part of the events for the day.

At the show, quite a few helicopters were displayed on the ground such as Aerospatiale Super Puma, Bell 222UT as well as Bell's single piston helicopters, in addition to demonstration flights. The show was also used as a market place by helicopter makers and trading houses in chalets.

Based on the government's Action Program to foster imports, Japan last year relaxed the regulations of heliport construction. In the circumstance, the helicopter demand for corporate use is now growing.

/13046

CSO: 4307/19

## AEROSPACE SCIENCES

### COMMERCIAL OPERATION TO BUY 42 HELICOPTERS IN FY86

Tokyo AEROSPACE JAPAN in English Jun 86 pp 68-69

[Text]

The Japanese commercial helicopter operators plan to purchase a total of 42 helicopters during the current fiscal year ending March 31, 1987, compared with 29 helicopters in the previous fiscal year.

Of the 21 commercial helicopter operators, 13 companies plan to buy new helicopters. Among such operators, New Japan Domestic Airline Co., Ltd. plans to buy as many as 9 helicopters for transportation of golfers, while Aero Asahi Corp. will purchase 8 helicopters including its second Aerospatiale Super Puma ordered last April. Though the demand is not necessarily strong, each of the companies seems quite enthusiastic about introduction of additional helicopters primarily because of strong yen.

In a breakdown by type, Aerospatiale AS350B tops the list of the helicopters to be purchase by the Japanese operators in FY'86. This is followed by Bell 222, Aerospatiale AS356F, AS332L and so on. Helicopter purchase plans break down by company as follows:

Aero Asahi Corp. . . . one each of AS332L, AS355F, AS350B, BO105CBS, and two each of Bell 222 and S-76 for a total of 8 helicopters.

Toho Air Service Co., Ltd. . . . one each of AS355 and AS350B for a total of 2.

Hankyo Air Lines Co., Ltd. . . . one each of AS355F1, Hiller UH12E or AS350B, and Bell 47KH4 for a total of 3.

Honda Airways Co., Ltd. . . . two AS350Bs and one Agusta 109A for a total of 3.

Imperial Air Line Co., Ltd. . . . two Bell 206Bs

Naka-Nihon Air Service Co., Ltd. . . . three AS350Bs

New Japan Domestic Airline Co., Ltd. . . . two AS322Ls and seven Bell 222Us or SA365Ns or BK117s for a total of 9.

All Nippon Helicopter Co., Ltd. . . . five AS350Bs (to be transferred) and one AS355FII for a total of 6.

Royal Av Co., Ltd. . . . one AS350B

Nishi-Nippon Airlines Co., Ltd. . . . one helicopter (type undecided)

Toa Domestic Airlines Co., Ltd. . . . two Bell 222s

Japan Helicopter K.K. . . . one Bell 47KH-4

Kansai Koku Yuso Co., Ltd. . . . one Hughes 300 or Enstrom F28

/13046

CSO: 4307/19

## AEROSPACE SCIENCES

### FOKKER ZEROS IN ON YS-11 REPLACEMENT MARKET

Tokyo AEROSPACE JAPAN In English Jun 86 p 69

[Text]

Fokker B.V has named Sumitomo Corp., one of the major Japanese trading houses, its sales agency to promote sales of the Dutch maker's Fokker 100 (109 passenger seats) fanjet and the Fokker 50 (60 seats) turboprop planes in Japan as the replacement of the YS-11 planes now in service on domestic local air routes.

The Fokker 100, which is due to make its first flight this fall, has already received orders totaling 69 aircraft (including 31 aircraft on option). The Fokker 50, of which first flight was made late last year, has received orders for 50 aircraft (including 12 on option).

Sumitomo will promote sales of the two planes to Toa Domestic Airlines and All Nippon Airways as the replacement of their 70 YS-11 planes. In addition, the company also aims at the short-haul commuter air transport market.

Full-scale competition for the YS-11 replacement sales is expected to begin next year. British Aerospace has already started sales with its Japanese sales agency Kanematsu-Gosho Ltd., another major Japanese trading house.

Fokker and Sumitomo also agreed to promote sales of the Fokker 50 and the Fokker 100 jointly in China, Middle East and Southeast Asia.

Shintoa Koeki Kaisha Ltd., an affiliate of Mitsubishi Corp., used to be the sales agency for Fokker. In beginning full-scale sales of the planes in Japan, Fokker decided to change its Japanese sales agency.

/13046

CSO: 4307/19

MEMORANDUM ON DEVELOPMENT OF COMMUTER PLANE SIGNED WITH PRC

Tokyo AEROSPACE JAPAN in English Jun 86 p 69

[Text]

Machinery and Information Industry Bureau Director General Hiromichi Sugiyama of the Ministry of International Trade and Industry (MITI) said, asked about the prospective Japan-China joint development of a new commuter plane at a Upper House session on April 10, "Japan has made its decision (in the direction of performing feasibility studies for a while). (Already) Japan has signed a memorandum of understanding (MOU) and sent it to China. If everything goes well, the two countries will likely reach an agreement on the feasibility studies around this May. Japan's decision on whether to start actually the joint development will be made based on the results of the feasibility studies."

He referred to the joint development with China in reply to a question asked by a Diet man of the 'Komeito' Party. Sugiyama made earlier similar reply to a question asked by a Dietman of the Socialist Party too.

The joint development was proposed by China last year to the Japanese civil aviation authorities. The Society of Japanese Aerospace Companies (SJAC) sent an aerospace technology delegation to China in late last August to exchange opinions. Then, the SJAC set up a "Chinese Project Promotion Special Committee" (chaired by Yoshio Sasaki, an executive of Mitsubishi Heavy Industries, Ltd.) to begin detailed studies on the joint development.

At the seventh medium/high working-level talks of the Japanese and Chinese governments held in Peking on November 18-19, the joint development was also brought up there. As a result, it was confirmed important for the two countries to carry out the joint project which has a significance in terms of industrial cooperation between Japan and China.

Sugiyama said, however, "Though the joint development with China is not necessarily excluded from the legal objects to be subsidized (under the government-aided New Scheme System), it is unlikely to give financial aids to the project for a while as the government is now tied up with the YXX and the V-2500 international joint development programs."

His comment is believed to have implied the government's negative view on the subsidies from the Funds of International Joint Aircraft Development.

AEROSPACE SCIENCES

CONSTRUCTION OF KANSAI INTERNATIONAL AIRPORT TO BEGIN

Tokyo AEROSPACE JAPAN in English Jun 86 p 68

[Text]

Full-scale construction of the Kansai International Airport is likely to begin this August with a view to opening in late FY'92 as the long pending fishery compensation agreement was finally signed on April 18 between Kansai International Airport Corp. and the Federation of Osaka Fishermen's Cooperative Associations through conciliation by Governor of Osaka Prefecture. The compensation totals ¥25 billion (or approximately \$150 million). The construction was initially scheduled to be started in March this year.

Kansai International Airport will be built on a man-made island 5 kilometers off Senshu in south of Osaka. Under the first phase planning, the airport to be constructed on a 500-hectare reclaimed land is designed to be operational around the clock with a 3,500-meter runway and an airport terminal.

Kansai International Airport Corp. which will construct and operate the airport is the so-called third sector company established jointly by the central and local governments and private enterprises. Kansai International Airport is Japan's first airport to be built by such a joint venture.

The presently used Osaka International Airport located in the north of Osaka cannot meet airlines' request for increased flights despite strong demand because of the limited number of jet flights, prohibited takeoffs and landings late at night, and strict noise pollution regulations like at John Wayne Airport in Orange Country, California.

/13046

CSO: 4307/19

## AEROSPACE SCIENCES

### MITI TO STUDY HYPERSONIC TRANSPORT

Tokyo JPE AVIATION REPORT-WEEKLY in English 28 Jul 86 p 1

[Text]

The Ministry of International Trade and Industry will inaugurate a special committee in FY 1987 in order to conduct feasibility studies on a hypersonic transport aircraft similar to a "New Orient Express", the concept of which was announced by US President Ronald Reagan last February.

MITI believes that the hypersonic transport it has in mind would be a collaborative project of the United States, European countries and Japan, and that it would be targeted for service entry in the early part of the 21st century.

The hypersonic transport will be powered by a liquefied hydrogen engine. It would not only be used as a passenger aircraft but as a transport vehicle capable of launching an artificial satellite, MITI sources say.

Mitsubishi Heavy Industries, Ltd. (MHI) has already begun preliminary studies on a Mach 5 engine. The Japanese Science and Technology Agency and the National Aerospace Laboratory are also promoting basic studies on such hypersonic aircraft. MITI plans to bring together those studies so that Japan can prepare for launching of an international collaborative project in the future.

President Reagan's "New Orient Express" will be able to link Washington - Tokyo in only about two hours. Complete development is estimated to cost approximately \$13,000 million.

/9317

CSO: 4307/21

AEROSPACE SCIENCES

NLA TO STUDY COPTER RESCUE SYSTEM

Tokyo JPE AVIATION REPORT-WEEKLY in English 28 Jul 86 p 1

[Text]

The National Land Agency (NLA) has started working out a system to utilize helicopters for transporting emergency and serious cases from mountainous regions inaccessible for ambulances to hospitals.

NLA has set up a study group on the emergency transport system for mountainous regions, which will draw a conclusion by the end of this year on ways to promote cooperation among local governments, hospitals and the Self-Defense Forces.

/9317

CSO: 4307/21

## AEROSPACE SCIENCES

### JAPAN, INDONESIA AGREE TO UNDERTAKE SURVEY

Tokyo JPE AVIATION REPORT-WEEKLY in English 28 Jul 86 pp 5, 6

[Text]

Japan and Indonesia signed a memorandum in Jakarta on July 7 on implementation of a survey on demand for transport in the island republic. The agreement emerged from an intergovernmental working-level meeting to discuss Indonesia's high-speed transit systems held in the Indonesian capital earlier this month.

The Japanese participants included working-level officials from the Foreign Ministry, the Ministry of International Trade and Industry, the Ministry of Transport and the government-controlled Japan International Cooperation Agency (JICA).

Conferees at the meeting discussed ways to improve the high-speed transit systems linking outlying islands, points in main islands, and outlying and main islands. In particular, they studied ways to use aircraft and ships under the systems, and even conducted field surveys. They chose the aircraft as the main transport means.

The Japanese government intends to send a second mission to Indonesia around September for consultations on specific ways to implement the planned demand survey. JICA is expected to lead the Japanese in the forthcoming survey, which will probably get under way on a full scale at the beginning of next year.

As a result of the two governments' selection of the aircraft as the main transport means in the improvement of Indonesia's high-speed transit systems, plans to develop small/medium transport aircraft, especially a small flying-boat, are expected to come to the fore.

In Indonesia, Prof. Dr. B.J. Habibie, Minister of Research and Technology, and President of Nurtanio Indonesian Aircraft Industry Ltd., has shown keen interest in the joint Japanese-Indonesian development of a small flyingboat. Under such circumstances, the two governments are likely to study a small flyingboat project in detail after outcome of the forthcoming demand survey is made available.

/9317

CSO: 4307/21

AEROSPACE SCIENCES

MITI TO MULL MEASURES TO PROMOTE SALES OF 7J7, V2500

Tokyo JPE AVIATION REPORT-WEEKLY in English 28 Jul 86 pp 6, 7

[Text]

The Ministry of International Trade and Industry (MITI) will convene the second meeting of the Aircraft Industry Council to discuss ways to further promote the international aircraft and engine collaborative programs in which the Japanese industry is participating. Discussions at the meeting will probably focus on sales financing measures, observers say.

The convocation of the meeting will follow the inauguration of the financing organization called "International Aircraft Development Fund," designed to finance the Boeing 7J7, International Aero Engines V2500 and other aircraft related international programs.

The Japanese aircraft industry and Boeing are jointly producing the 767 aircraft with loans from the Japanese government. They have also launched joint research on the 7J7 new 150-seater aircraft project.

The V2500 engine development has been undertaken by the consortium of Japan, Britain, the United States, West Germany and Italy.

Accordingly, the panel is expected to study specific measures to establish sales financing measures for prospective buyers of the 7J7 and the V2500 both at home and abroad at the forthcoming meeting.

In the case of exports of 767s, a joint financing scheme between the Japanese government and Boeing was realized for Transbrasil Airlines.

/9317

CSO: 4307/21

## AEROSPACE SCIENCES

### NIKKESO-BOEING MAY SET UP JOINT VENTURES

Tokyo JPE AVIATION REPORT-WEEKLY in English 28 Jul 86 pp 7, 8

[Text]

Nikkiso Co. and Boeing Co. recently reached a basic agreement to set up joint ventures both in Japan and the United States next spring at the earliest to produce carbon fiber materials for aircraft and develop other kinds of new materials. The new companies will start producing cascades for thrust reversers and other PAN carbon fibers next spring, if things go smoothly. Details of the joint ventures will be worked out from now on.

This will be Nikkiso's first joint venture in the new materials field. The new company to be established in Japan, in which Nikkiso will have a majority stake, will set up a plant within the compound of Nikkiso's Shizuoka Plant to manufacture five to six tons of PAN carbon fibers initially.

The U.S. joint venture, in which Boeing will take a majority stake, will likely be established in Oak Ridge, Tennessee. It will turn out 10 to 20 tons of PAN carbon fibers initially. All the carbon fibers to be produced by the two joint ventures will be supplied to Boeing.

Nikkiso developed the technology to manufacture ultra-strong PAN carbon fibers two years ago. It provided the technology to Boeing last March and the two companies have been conducting research on ways to use the PAN carbon fibers as materials for aircraft parts since then.

Nikkiso claims that the cascade made of PAN carbon fibers is light and very strong. It has also succeeded in development of the technology for continuous manufacturing of the graphite whisker, a reinforcing material.

/9317

CSO: 4307/21

AEROSPACE SCIENCES

KHI, SWISS COMPANY SIGN AGREEMENT ON GAS TURBINES

Tokyo JPE AVIATION REPORT-WEEKLY in English 28 Jul 86 p 8

[Text]

Kawasaki Heavy Industries, Ltd. (KHI) signed a licensing agreement with Brown Boveri and Co. Ltd. (BBC) of Switzerland last week on production and marketing of industrial gas turbine engines. The agreement is valid for 10 years.

KHI will be licensed to produce BBC's gas turbines ranging from 35,400 kw to 98,500 kw. It also plans to produce a 142,900 kw unit in the future. BBC's gas turbines can use all kinds of fuel including LNG, kerosine and heavy oil.

KHI plans to market BBC designed gas turbines for use in iron works and petrochemical plants.

/9317  
CSO: 4307/21

AEROSPACE SCIENCES

NASDA LAUNCHES RESEARCH ON POWER SUPPLY SYSTEMS

Tokyo JPE AVIATION REPORT-WEEKLY in English 28 Jul 86 pp 8, 9

[Text]

Japan's National Space Development Agency (NASDA) has launched research on a system to generate supplemental electric power for a Japanese manned experimental module to be linked to the proposed U.S. Space Station.

This followed the U.S., National Aeronautics and Space Administrations's (NASA) rejection of NASDA's request for power supply of at least 5 kwh needed to maintain and operate the Japanese module. NASA said it would provide 4 kwh.

NASDA will look into costs and technical problems involved in the inclusion of a power generation system in the module for the time being.

Preliminary studies indicate that attaching solar cells to the outer part of the Japanese module's pressurized section, a cylinder-type object measuring 4 meters in diameter and 10 meters in length, for power generation will be the most feasible idea. This setup will enable the generation of about one kwh of power. Experiments will begin in or after 1994.

The U.S. Space Station will be equipped with ultra-large solar panels and solar power plants to generate 75 kwh of power. Japan and European countries, which plan to link their experimental modules to the U.S. Space Station, have asked NASA to supply them with sufficient power.

/9317  
CSO: 4307/21

## NEW MATERIALS

### TRENDS IN R&D OF NEW METALLIC MATERIALS DISCUSSED

#### Present Status, Future Trends

Tokyo KOGYO ZAIRYO in Japanese Oct 85 pp 26-28

[Article: "A Review of Trends of the Development of New Metallic Materials:  
[Part 1] Present State and Future Trends of New Metal Materials"]

[Excerpts] With rising concern in recent years for new materials, corporations are charging ahead with relevant research intensively and attaining practical applications in many cases. Because of the limitations involved in existing materials and because of the need for new materials of higher function, development of superior materials is acutely desired. New materials for which research and development [R&D] is moving ahead and which have prospects of major expansion, in general, are: 1) high-performance polymers, 2) fine ceramics, 3) new metal materials, 4) composite materials.

High-function polymer materials display functions which have not been available from the old polymers. These include, for example, high-strength and high-electric conductance, which compare with metals, and capacity for separating and extracting component materials from mixtures. These and other desirable functions have a wide range.

Fine ceramics represent an inorganic, non-metallic material which, in contrast to so-called ceramic products such as glass, potteries, etc., which have been daily necessities from ancient times, are prepared with high precision, from highly purified, finely divided material and afforded high functions. Their applications range widely, from structural materials to electronic and medical uses.

New metal materials, as opposed to conventional metals of iron, aluminum, copper, lead, etc., are capable of new functions such as contraction and expansion like rubber or change of shape with temperature. Their application ranges from household goods to space and nuclear-power technologies.

Composite materials, finally, are those in which high functions are materialized by combining plural numbers of raw materials, as can be seen in FRP combining carbon fiber with a plastic, and in FRM combining alumina fiber with a metal. Their applications are rapidly expanding, ranging from

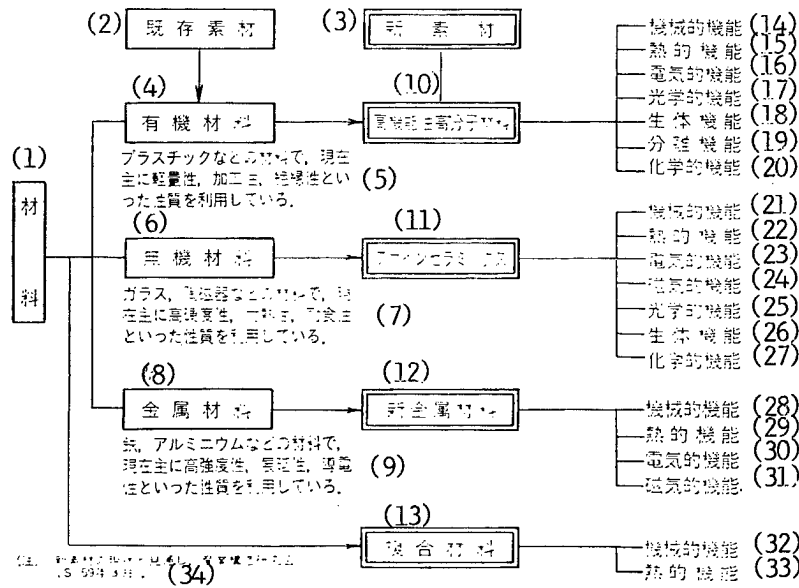

Figure 1. System of New Materials

Key:

1. Materials
2. Conventional materials
3. New materials
4. Organic materials
5. This type of material is used for plastics, etc., and applications are based largely on its properties of light weight, workability, insulation, etc.
6. Inorganic material
7. This type of material relates to glass, ceramics, etc., and applications are based largely on properties of high hardness, resistance to heat, resistance to corrosion, etc.
8. Metal materials
9. This type of material, including iron and aluminum, finds applications largely on the basis of its properties of high strength, malleability, ductility, electric conductivity, etc.
10. Materials for polymers of higher functions
11. Fine ceramics
12. New metal materials
13. Composite materials
14. Mechanical function
15. Thermal function
16. Electric function
17. Optical function
18. Biological function

[Key continued on following page]

[Key for Figure 1 continued]

19. Separation function
20. Chemical function
21. Mechanical function
22. Thermal function
23. Electrical function
24. Magnetic function
25. Optical function
26. Biological function
27. Chemical function
28. Mechanical function
29. Thermal function
30. Electric function
31. Magnetic function
32. Mechanical function
33. Thermal function
34. (Note) Source: "The Present State and Prospects for New Materials"  
by the Institute for Research of Industrial Structures (March 1984)

aeroplanes to various types of materials related to internal combustion engines and, most recently, in the sector of recreational and sporting goods. Functions required of each of these materials are represented in Figure 1. The present feature article deals with new metal materials, in particular, among these materials, and reviews present development trends and future problems.

New metal materials may be grouped into various types by functions and applications. Current articles, nevertheless, pick up largely the following materials in order to look into their present state of development: a) shape-memory alloys, b) amorphous alloys, c) hydrogen-storage alloys, d) super-conducting alloys, e) alloys super-resistant to heat.

### Shape Memory Alloys

This type of alloy was discovered long ago. A research team of the University of Illinois found the unique phenomenon that an alloy of gold and cadmium changes shape as its temperature changes, for the first time in the early 1950's. This fact, however, attracted scant attention from researchers at the time. Full-scale research and development started with the discovery, by a research institute of the U.S. Navy, of a nickel-titanium alloy which exhibited the same property. With the progress of the research and development involved, shape memory alloys of a copper series, such as copper-zinc and aluminum alloys were later commercialized, and, more recently, the development of iron alloys has commenced.

The alloy was made generally known by its application in an antenna on the surface of the moon carried by NASA's Apollo moon rocket. The parabolic antenna, which changes its shape by solar heat and works on the moon's surface, was shipped to the moon by the rocket in small folded form but regained its original semi-spherical shape to serve as an antenna on the moon after it had reached there. Other practical applications of the alloy, however, seem to have followed only since the 1970's.

The shape memory alloy is currently in transition from the developmental to the commercialization stage. The first example of its successful application seems to be a pipe joint. Another that followed it is seen in the sector of electric appliances. The alloy found use in the flap of an air conditioner as an automatic converter of wind direction; i.e., with a view to stepping up the efficiency of air conditioning. A flap attached to the site where the wind blows out directs the wind downward when it is warm and upward when cold, with the shape memory alloy of the flap switching the direction of the wind up or downward automatically by sensing the temperature of the wind.

In comparison with the mechanism coupling a motor with a thermistor or a semiconductor device for sensing temperature, which was the conventional method, the new mechanism involving the alloy is said to have greatly reduced the number of components required.

On the basis of the unique functions exhibited by this type of alloy, researchers are also going ahead step by step with commercialization of various ideas for the application of the alloy. For example, orthopedic

applications were under study as material for medical use and, similarly, an artificial tooth-root was developed for dental purposes. Robots using the alloy as a material have likewise been trial-manufactured and spotlighted in industry.

It is true that commercialization of the alloy has advanced in a large measure. Its characteristics and methods of application, nevertheless, have yet to be fully explored and areas of its application still are limited. Practical data is not adequately available for designing the alloy, and much hope is pinned on future development.

Among the major corporations engaged in the development and application of this alloy are: Furukawa Electric; Sumitomo Special Metal Co., Ltd.; Mitsubishi Metal Corp.; Tohoku Metal Industries, Ltd.; Hitachi Metals, Ltd.; and Daido Steel Co., Ltd.

#### Amorphous Alloys

Amorphous metals that lack a crystalline structure, such as glass, are prepared by a rapid quenching of molten alloys at a rate of 100,000 degrees C/second. The metals thus artificially produced provide excellent characteristics in super-high hardness, high strength, superior resistance to corrosion, magnetic characteristics, etc., which are not available from crystalline metal materials in general.

Amorphous metal, being noncrystalline and, in that sense, having a structure similar to that of glass, is alternatively referred to as metal glass. Nevertheless, it has mechanical, chemical, and magnetic properties different from those of crystalline metals, hence the prospect of diverse applications based on these properties.

Amorphous metals have superior hardness and tensile strength but poor workability, and they are not amenable to welding. They are, therefore, hardly available as structural materials and currently have the prospect of being used as a reinforcement component in composite materials, i.e., fibrous amorphous metals are mixed with rubber tire, plastics, polymer materials, etc. One major application of the metal is the magnetic head based on the magnetic properties of the alloy, and applications in VTR's, computers, and sound equipment will advance. Major corporations engaged in development and applications are: Nippon Steel Corp.; Kawasaki Steel; Hitachi Metals; Nihon Mining Co., Ltd.; Hitachi, Ltd.; Toshiba; Mitsubishi Electric; TDK; and many others.

#### Hydrogen Storage Alloys

Hydrogen storage alloys represent material which, upon cooling or pressuring, absorbs hydrogen resulting in metal hydrides with heat generation which, upon heating or depressuring in contrast, gives back the hydrogen with heat absorption. Storage of hydrogen with this alloy, therefore, reduces the volume of hydrogen gas to be stored to one-third to one-fifth. There is, besides, neither the danger of the gas exploding nor the need for an extremely low temperature as is true in liquefaction of the gas. The alloy's unique

property was first discovered in 1968 at the Brookhaven National Research Laboratory in the United States. It has conceivable applications largely in the storage and transfer of hydrogen and also in air conditioning on the basis of heat generation and absorption involved in the reversible reaction. Research on hydrogen automobiles has been progressing, meanwhile, because of the adverse effects of exhaust gas of conventional automobiles. Corporations continuing development on this type of alloy include: Nippon Heavy Chemical Industry Corp.; Daido Steel Co., Ltd.; Mitsubishi Steel Manufacturing Co., Ltd.; Nippon Kokan; Kawasaki Heavy Industry.

### Superconductive Materials

The electric resistance of certain substances falls to zero at and below a certain temperature unique to the substance--a phenomenon referred to as superconductivity. This permits large currents to flow without power loss and magnetic fields of high intensity to be generated. Among the applications of this superconductivity phenomenon are magnets used in MHD [magneto-hydrodynamic] power generation, nuclear fusion, automobiles, ships propelled by superconductive magnets. The nuclear magnetic resonance computer tomography represents applications in medical sectors. Developmental research is being conducted in sectors of large, superhigh-speed computers and electric power storage. Practical materials for the applicable wire are represented largely by niobium titanium alloy, vanadium-3 gallium, and niobium-3-tin, and are manufactured in the main by heavy electric equipment makers such as Toshiba, Hitachi, Mitsubishi Electric, and Fuji Electric, Furukawa Electric, Showa Electric Wire, Sumitomo Electric Industries, Kobe Steel, and Nippon Vacuum Metallurgy.

### Alloys of Superhigh Resistance to Heat

In the past, high temperatures were always dealt with by heat-resistant steel. They never afforded fully satisfactory results, however. Recent years have seen the development of alloys of superhigh resistance to heat. The high-strength alloy, which is as heat resistant as it is resistant to corrosion, finds applications, on the basis of these properties, in jet engines, rockets, gas turbines, high-temperature gas-cooled reactors, heat exchangers, etc., over a wide range, and is now accounted for largely by nickel based alloys. Japan has a high level of technology in the development of this alloy, with research and development moving ahead by the concerted effort of the government and private corporations, led by the National Research Institute for Metal of the Science and Technology Agency.

### Recent Trends--Setting Up of a New Material Center for Metals

With a view to stepping up research and development of new metal materials, MITI is going to set up a New Material Center for Metals--tentatively named--which combines the function of testing and assessment with that of research and development on the material.

MITI plans to set up the center by next year as a legal foundation shared by makers and users of metals, the government, and universities. The Ministry is going to materialize the plan as part of new policies for fiscal 1986, and

intends to have the center fulfill largely such functions as testing and assessment of new metal materials; survey and research testing technologies, assessments and guidance, setting up a data bank and international exchange of researchers and information.

First of all, the center will embark on: a) testing and assessment of functional metal materials; b) testing hazardous environments; c) testing for biological adaptability; etc. The testing and assessment of functional materials will involve infrared spectroscopy, secondary ions mass spectrometry, transmission electron microscopes, x-ray diffraction of ultraprecision, Auger-electron spectroscopy, x-ray-excited electron spectroscopy, etc. These will be fully utilized in order to test the characteristics of metal crystals and devices. New metal materials to be subjected to testing include composite materials, shape memory alloys, hydrogen storage alloys, amorphous alloys, and electromagnetic special alloys. In hazardous environment tests, meanwhile, data is to be collected for mechanical and functional characteristics of the material in the space environment, e.g., those of high vacuum, below  $10^{-5}$  torr, and those of exposure to radiation (over 10 rad in terms of the corresponding  $\gamma$ -ray value). In the marine environment, tensile and compression tests will be made under high pressure in salt water.

The standardization of new metal materials and testing and assessment methods will be advanced, and, on these bases, a national standard will be set up.

Besides the above, testing and assessment services will be made on the new metal materials for the sake of small- and medium-size enterprises.

#### Superconductive Material

Tokyo KOGYO ZAIRYO in Japanese Oct 85 pp 29-33, 39

[Article by Yasuzo Tanaka of Furukawa Electric Co., Ltd.]

[Text] More than 70 years have passed since H. Kamerlingh-Onnes discovered the so-called superconductivity phenomenon of zero electric resistance in 1911. However, the practical application of this phenomenon took a fairly long period, though the year 1957 saw J. Bardeen, et al., put forward the BCS theory. In 1962, Josephson reported on the Josephson effect. The phenomenon of superconductivity, conceivably, had not found its actual application until the latter half of the 1970's. An advance of superconductivity from the research sectors of nuclear fusion and high-energy physics to the medical sector of NMR-CT, etc., in particular, is of significance in that superconductive materials have been admitted as one of the new industrial materials.

The present article deals with the current state of the technologies and applications for superconductive materials and their future. It, further, discusses the special requirements for the material in each sector of application.

## Nature of Superconductivity

What are the differences in electric conduction mechanisms between the superconductivity of zero electric resistance at very low temperatures and normal electric conductivity? The electric resistance for metal of normal electric conductivity results from a reciprocal action between individual conducting electrons and atoms located at each lattice site. The electric resistance of a superconductive body, meanwhile, is accounted for, by the BCS theory,<sup>1</sup> as being produced also by the mutual reaction between electrons and phonons, i.e., quantized lattices. In the case of superconductivity, however, the resistance falls to zero only when two electrons, with both their momentums and spins in opposite directions, form a pair (Cooper's pair) via the lattices (phonon) and migrate through the space through the lattices, exchanging energy with one another. The typical properties of superconductivity are perfect electric conductivity and perfect die magnetism. Figure 1 compares specific resistances, which, for the substances of superconductivity, are generally defined as below  $1 \times 10^{-19} \Omega \text{ cm}$ . The other feature of superconductive substances is their zero magnetic field. That is, the magnetic flux is prevented from expanding into them. To be more precise, the magnetic flux penetrates the superficial layers of thickness  $0.01\text{-}0.1 \mu \text{m}$  of the first type of superconductive substances. The persistent current is allowed to flow inside of the conductor where it seems as if the magnetic flux there is completely thrust out. In the second type of superconductive substance, on the other hand, the magnetic flux penetrates the substance in a regular manner, producing a mixed condition [as published] which yet permits the superconductive state to hold on.

Where its chemical composition and its pressure are kept constant, the superconductive state is determined by temperature  $T$ , magnetic field intensity  $H$ , and electric current density  $J$ , with each of these parameters having a critical value. For example, when the temperature of a superconductive substance is made to go up gradually from an extremely low value, the superconductivity is replaced by normal conductivity at its critical temperature  $T_C$ .

Known superconductive substances presently comprise 34 types in the elemental state and 10 types in raised pressure conditions. If compounds, alloys, and organic compounds are added, the total is said to be well over 1,000 types. Table 1 presents the values of  $T_C$  and  $H_C$  for representative superconductive substances.<sup>2</sup> The maximal value of  $T_C$  is 23.2 K of  $\text{Nb}_3\text{Ge}$  and that of  $H_{C2}$  of  $\text{PbGd}_{0.2}\text{Mo}_6\text{S}_8$ . If substances with higher  $T_C$  become available, that is, if materials which can maintain superconductivity at a liquefaction temperature of hydrogen of 20.4 K or of nitrogen of 77 K, the material will see its applications further expand. Organic superconductive materials, conceivably, will make higher  $T_C$  values available.<sup>3</sup> The values of  $T_C$  and  $H_C$  are dictated largely by the microscopic electronic structure of the material and hence by its crystalline structure, its composition, and the degree of orderliness of the crystal, among other things. The critical current density  $J_C$ , on the other hand, is dependent largely on the macroscopic structure of the material, such as dislocation nets, deposited substances, and grain boundaries of the crystal and affected, in large measure, by processing methods of the material.

(1) 物名	Tc (K)	Hc (T)	(1) 物名	Tc (K)	Hc (T, 4.2K)
Al	1.196	0.0099	Nb 60Ti	9.3	12.0
In	3.403	0.0293	Nb 25Zr	10.8	7.5
Sn	3.722	0.0303	V <sub>3</sub> Ga	16.8	21.0
Hg	4.153	0.0412	Nb <sub>3</sub> Sn	18.1	24.5
Ta	4.433	0.0830	Nb <sub>3</sub> Al <sub>0.2</sub> Ge <sub>0.2</sub>	20.7	41.0
V	5.3	0.1020	Nb <sub>3</sub> Ge	23.2	35.0
Pb	7.193	0.0803	PbGd <sub>0.2</sub> Mo <sub>0.8</sub> S <sub>8</sub>	13.8	61.0
Tc	7.92	0.1410	NbN	15.7	13.0
Nb	9.13	0.1980	V <sub>3</sub> Hf	8.8	20.0
			(TMTSF) <sub>2</sub> ClO <sub>4</sub>	1.2	-
			SiNx	0.3	-

(2) ただし、T(テラス): 10,000G(カウス)

Table 1. Tc and Hc of Major Superconductive Materials in telas and in 10,000 gaus

Key:

1. Material
2. In telas (T) and 10,000 gaus (G)

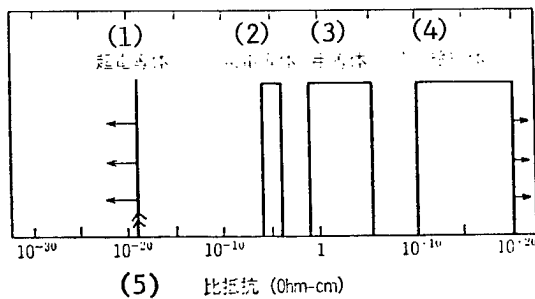

Figure 1. Comparison of Specific Resistances of Materials

Key:

1. Specific resistance
2. Materials of super conductivity
3. Materials of normal conductivity
4. Semiconductors
5. Insulation materials

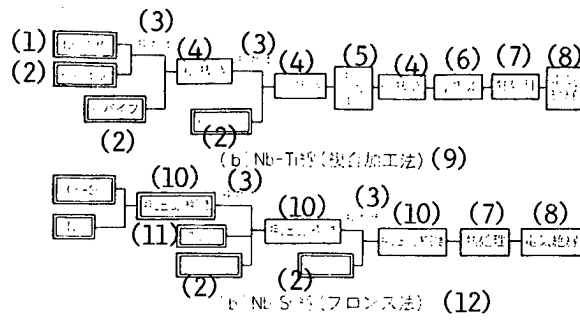

Figure 2. Process of Manufacture of Practical Superconductive Wires

Key:

1. Nb-Ti rods
2. Copper pipes
3. In plural number
4. Drawing out
5. Intermediate annealing
6. Switching
7. Heat treatment
8. Electric insulation
9. Nb-Ti rods (the composite processing method)
10. Extrusion, wire drawing
11. Ta [tantalum] pipes
12. Nb<sub>3</sub>Sn wires (the bronze method)

## Methods of Manufacture of Practical Superconductive Materials

### 1. Conditions Required for Superconductive Materials

Practical superconductive materials fall largely into five types, as shown in Table 2, and must meet the special conditions dictated by their applications and methods of application.

In the case of NbTi and Nb<sub>3</sub>Sn, large currents are passed and high-intensity magnetic fields produced, a case of large power application. The requirement here is a stabilizing technology that permits elimination of magnetic instability. The second type of superconductive materials, which permit a magnetic flux to invade them regularly, may have their superconductive state destroyed after repeating cycles of  $J_C$  drops and magnetic flux invasion in cases where the magnetic flux somehow moves and generates heat. This instability is eliminated when the superconductive material, in the form of very thin filaments of diameters in scores of microns, is buried in the copper matrix. The transmission through the portion of normal conductivity is further limited by coating the filaments with copper or aluminum of high purity or by providing grooves for cooling.

In the case of pulse magnets and varying magnetic fields, losses due to hysteresis and eddy current which accompany the shift of magnetic flux have to be diminished. In order to step up the dynamic properties of the complex multicore wires, the diameter of the filaments is reduced, the external diameter of the multicore wire reduced, and the filaments subjected to either a twisting or an intertwining process. Furthermore, a three-layer structure in which the copper matrix surrounding the filaments is further partitioned by a material of high electric resistance like cupronickel is used sometimes in order to reduce coupling loss among the superconductive filaments.

### 2. Manufacture Method

The manufacture of superconductive wires is accomplished largely by composite processing, as seen in Table 2. The manufacturing process of commercial wire rods is presented in Figure 2. In the case of NbTi wires, NbTi rods are buried in copper pipes, their diameters are reduced, and they are subsequently buried again in copper pipes. This method, the most firmly established of the manufacturing technologies is also applicable for wires of the compound Nb<sub>3</sub>Sn. The manufacture of this compound wire uses bronze as the matrix and the method involved is referred to as the bronze method. In the bronze method, the material is turned into a product close to the final product in size by means of composite processing. It is subsequently subjected to a diffusion reaction such that the compound Nb<sub>3</sub>Sn is formed at the interface between niobium and the matrix bronze.

### Characteristics of Superconductive Wire Rods

#### 1. Improvement of the Critical Electric Current Density $J_C$

The critical temperature  $T_C$ , the critical magnetic field intensity  $H_{C2}$ , and the critical electric current density  $J_C$ , which are the basic properties of

(1)	(2)	(3)	(4)
形態	超電導材料	製造方法	用途
(5) 多 芯 線	NbTi	(7) 析出法	複合加工法 (13)
		(8) 拡散法	表面拡散法 (14)
	複合加工法 (15)		
	In-Situ法 (16)		
	VaGa	(9) 化学的	CVD法 (17)
(10) 変態法		変態析出法 (18)	
(6) フ ィ ル ム	Pb	(11) 物理的	真空蒸着法 (19)
			スパッタリング法 (20)
	Nb	(12) 化学的	CVD法 (21)
			プラズマCVD法 (22)

□ 工業的方法 (25)

Table 2. Methods of Manufacture of Practical Superconductive Materials

Key:

1. Form of the product
2. Superconductive material
3. Method of manufacture
4. Application
5. Multicore wire
6. Film
7. Deposition method
8. Diffusion method
9. Chemical method
10. Modified method
11. Physical method
12. Chemical method
13. Composite processing
14. Surface diffusion
15. Composite processing
16. In-site method
17. CVD method
18. Modified deposition method
19. Vacuum (vapor-)deposition method
20. Sputtering method
21. CVD method
22. Plasma CVD method
23. High-power applications: for large currents for strong magnetic fields, for electromagnets, and for power transmission
24. Low-power applications: for low or very small magnetic fields, for elements and devices
25. Industrial method

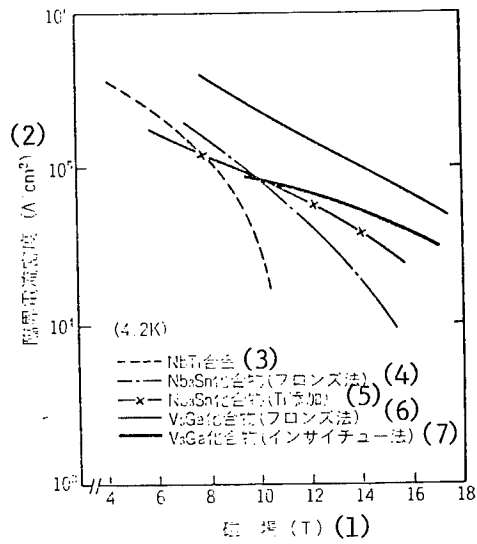

Figure 3. Critical Current Density of Various Types of Superconductive Wires

Key:

1. Magnetic flux density T [tesla]
2. Critical current density
3. Nb-Ti alloys
4. Nb<sub>3</sub>Sn compounds (the bronze method)
5. Nb<sub>3</sub>Sn compounds (titanium added)
6. V<sub>3</sub>Ga compounds (the bronze method)
7. V<sub>3</sub>Ga compounds (the In Situ method)

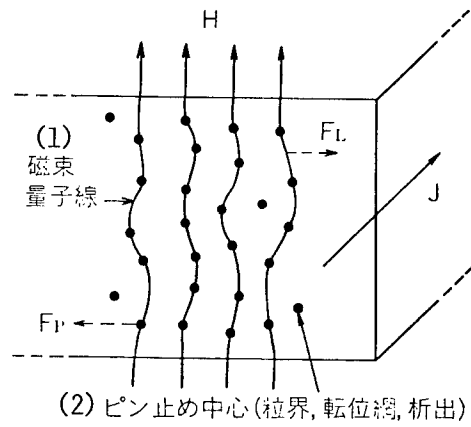

Figure 4. Pinning of Fluxoid-Quantum Lines in Superconductors of the Second Type

Key:

1. Fluxoid-quantum line
2. Center of pinning (grain boundaries, dislocation nets, depositions)

superconductivity, need to have higher values if a superconductive magnet is to produce higher magnetic field intensity and to be made smaller in size. The values of  $T_C$  and  $H_{C2}$ , nevertheless, are inherent to the material and cannot be improved appreciably by mere modifications of the manufacturing method etc. The  $J_C$ , on the other hand, is sensitively affected by the macroscopic structure of the metal and has been improved to more than double the value of a decade ago as a result of many ingenious devices made in the manufacturing process. Figure 3 presents a plot of  $J_C$ 's per cross sectional area against magnetic field intensity for various superconductive wires other than stabilized copper.

When a conductor of the second type of superconductive materials, e.g., the alloy NbTi or the compound  $Nb_3Sn$ , is put in a magnetic field of intensity  $H$  with a current  $J$  applied, a Lorenz force  $F_L$  acts on the magnetic flux as shown in Figure 4. Meanwhile, grain boundaries, deposits, and other pinning points in the conductor work to prevent the flux from shifting. The greater the latter force, which is referred to as pinning force  $F_p(J_C B)$ , the greater will be the value  $J_C$  and the more valuable will be the wire.

In the alloy NbNi, the value of  $J_C$  is improved by subjecting the material to heavy processing from the  $\beta$  phase to give a wire of cross-sectional area below  $10^{-4}$ . This is done by subjecting the material to an aging heat process and allowing it to deposit a fine  $\alpha$ -Ti phase which serve as pinning points, or by coupling this process with a heat treatment. Meanwhile, in the compound  $Nb_3Sn$  wire, the pinning force increases in proportion to the reciprocal of the diameter of crystal grain in the  $Nb_3Sn$  layer. The value  $J_C$  is thereby improved by making the crystal grain more fine. Furthermore, where superconductive materials intended for high magnetic-field intensity are concerned, the addition of a third element to the superconductive material produces an improvement in  $J_C$ , for example, the addition of tantalum<sup>4</sup> to the alloy NbTi and that of titanium<sup>5</sup> to the compound  $Nb_3Sn$ . The improvement of the value  $J_C$  is also expected when the temperature of the cooling medium is brought below 4.2 K--an assumption having been proved for the alloy NbTi.

## 2. Improvement of Resistance to Stress

Superconductive wire rods are subjected to mechanical and electromagnetic stress and strain in the manufacturing process of magnets or of excitation of the coil. Figure 5 shows a plot of  $B_{C2}$  against stress for various superconductive wires.<sup>6</sup> A decline in  $B_{C2}$  leads to declines in  $J$  and  $(B)$ . It is, therefore, apparent that compound wires are more sensitive to stress than alloy NbTi wires. It is true that the compound type of superconductive wires is subjected to a compression stress of coefficient 0.3 percent due to the difference in thermal expansion rate of the materials involved as these wires are a compound body in a bronze matrix. They nevertheless exhibit no deterioration of performance even if subjected to a tensile strain of coefficient around 0.6 percent, thereby permitting designs of practical magnets. This elucidation has led to a major advance in the practical application of the compound type of superconductive wires.

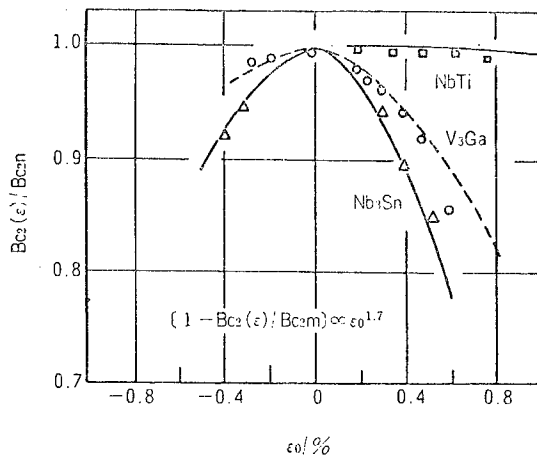

Figure 5. Plot of  $B_{c2}$  (4.2 K) Against Deformation for Practical Composite [Superconductive] Alloy Rod Wires (All represented by universal curves)

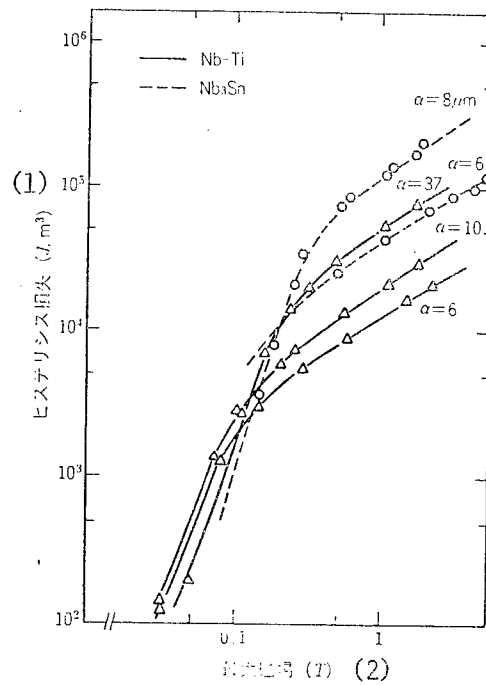

Figure 6. Plot of Hysteresis Loss Against the Maximum Magnetic Induction for the Wires of the Nb-Ti Alloy and the Nb<sub>3</sub>-Sn Compound

Key:

1. Hysteresis loss
2. Maximum magnetic induction in T [or tesla]

### 3. Low Alternating Current Loss

In high-uniformity magnets, in the case of pulse magnets, AC generators, etc., where large variations in the magnetic field are involved, and in applications where AC current is used, conductors of low AC loss are required. An approximation for the assessment of the superconductive wires of AC current application is given by

$$W = \frac{8df\lambda J_c(B_m)B_m}{3\pi} + \frac{B_m^2 f^2 l_p^2}{2\rho^2}$$

Where  $W$  denotes the total loss ( $W/m^3$ ),

$d$  the diameter of the filaments (m),

$f$  the frequency,

$\lambda$  the rate of area occupied by the filaments,

$J_c(B_m)$  the total electric current density ( $A/m^2$ ) at the maximum magnetic induction  $B_m$ ,

$B_m$  the maximum amplitude of magnetic induction in the alternating field,  $l_p$  the twist pitch of the filament,

and  $\rho$  specific resistance of the conductor in its vertical direction ( $\Omega m$ ).

The first term of this approximation represents the loss due to hysteresis, which is made smaller by reducing the diameter of the filament  $d$ . Figure 6 shows a plot of hysteresis loss versus magnetic inductance for varying diameters of alloy NbTi wires and the compound Nb<sub>3</sub>Sn. It is apparent from the figure that the hysteresis loss is proportional to the diameter of the filament. Wires currently developed as conductors for commercial frequencies are of filament diameters 0.3-0.5 microns.<sup>8</sup> The second term of the above equation denotes the loss due to coupling of the filaments, which drops with decreasing twist pitch of the filament and increasing specific resistance of the matrix. The twist pitch is dictated largely by the external diameter of the filament. Growing importance, therefore, is being attached to the technology of the complex processing. The twist pitch of 0.5-mm is regarded as the present minimum possible limit for external wire-diameters of around 0.1-mm. Meanwhile, a specific resistance of the matrix of  $10^{-7} \Omega cm$ , has been attained by introducing the above three-layer structure.

Under these processing conditions, which are close to the possible limit for compound substances, the technology of utmost significance is the total elimination of the break and construction of the filaments.  $J_c > 2.7 \times 10^5 A/cm^2$  (5T) affords a high credibility to the alloy NbTi having a filament diameter of 3  $\mu m$  as does  $J_c > 2.3 \times 10^5 A/cm^2$  (8T) to the compounds Nb<sub>3</sub>Sn with filament diameter 1  $\mu m$ .

#### Applications of Superconductive Wires and Their Future

##### 1. Physical and Chemical Research Sector

The development of the technologies of superconductive magnets and wire rods comes in great measure from magnets for physical and chemical research and, in particular, from high-energy particle accelerators. In the sector of high-energy physics, superconductive magnets of enormous size are necessary for use

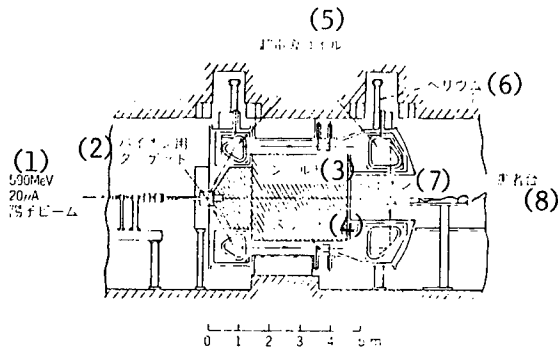

Figure 7. Diagram of Biotron

Key:

1. Proton beam
2. Target for Bion
3. Shield
4. Slit
5. Superconductive coil
6. Helium
7. Bion beam
8. Table for examining patients

in bipolar and tetrapolar magnets, which respectively deflect and focus beams, as well as in collision detectors and bubble chambers for elementary particle detectors.

The largest current energy accelerator in the world is the superconductive proton synchrotron of the Fermi Research Institute, United States, which has reached the level of 800 GeV.<sup>10</sup> An accelerator of 20 TeV, furthermore, is being embarked on also in the United States. Another high technology in the sector of superconductivity is found in the development of nuclear-fusion facilities of the magnetic confinement type and a superconductive magnet of high magnetic field intensity. Whereas the magnetic field intensity accomplished exclusively by a superconductive magnet is 17.5 T at maximum presently, a hybrid method combining the superconductive magnet and the normal conductive magnet has recorded a value of over 30 T.<sup>11</sup> This achievement has contributed greatly to the development of the toroidal coil of the tokamak-type nuclear fusion reactor and to that of the axis cell coil in the thermal barrier of the nuclear fusion reactor of the tandem mirror type.

## 2. Apparatuses for Nuclear Magnetic Resonance, NMR<sup>12</sup>

If the distribution of a substance and its molecular structure are to be elucidated by the NMR, the following requirements have to be met: a) high magnetic field, b) high uniformity of magnetic field, c) stability of the function throughout a certain fixed period of time. Superconductive magnets meet all of the above requirements most satisfactorily.

The NMR-CT for diagnostic purposes makes the utmost of this magnet. With a uniformity of its magnet field of over  $10^{-8}$  and with a stability of  $10^{-6}$  per day, the magnet permits the persistent current modes of operation and small-size freezer attachment. The equipment, of which over 300 units are currently in operation in major medical institutions of the nation, has prospects for increasingly generalized applications as it serves, in great measure, to discover malignant tissues of the body in an earlier phase of the disease.

In addition, the superconductive magnet finds application also in deflecting beams of biotron equipment for therapeutic purposes<sup>13</sup> (Figure 7). A superconductive toroidal magnet, which is incorporated in this biotron equipment, is capable of sharply deflecting  $\pi$ -mesons produced by the collision of a proton beam onto the target, and thus leading the meson to the afflicted portion of the patient.

### 3. Applications for Energy and for Industrial Equipment

Where the utilization of energy is concerned, the nuclear fusion reactor represents the ultimate application of the magnet. In terms of the storage of magnetic energy, nevertheless, only around one-tenth of the size of the target capacity has been attained and many problems exist in connection with the expansion of its capacity, though much hope rests on it. One can but admit that the superconductive technologies required involve high degrees of difficulty. For example, the tokamak type requires a conductor of low AC loss for use in the superconductive poloidal magnets that apply heat to plasma. Also, the mirror type needs an axis cell magnet capable of generating an intense magnetic field of over 20 T. The energy sector also has seen the application of the magnet in MHD power generation, in energy storage, in power transmission, etc. However, these applications are all economically practicable on the large scale only, and are dictated, in large measure, by the fluctuation of demand for energy.

In the sector of industrial machines and equipment, application in AC power generation is conceivable. As referred to above, this application is connected, in large measure, with the development of a superconductive wire of very low AC loss. The problem involved has changed in phase from the development of a superconductive rotor to that of a superconductive armature--the component which is affected by the alternating current to the greatest extent.

Applications of superconductive magnets in the semiconductor industry are the focus of interest where industrial applications of the magnet are concerned. First, the magnet has an application in the prevention of the convection of melts during pulling of the single crystals of silicon and gallium arsenide.<sup>14</sup> Also being diligently developed are copying apparatuses<sup>15</sup> using electron beams that incorporate superconductive magnets of high uniformity and lithographic apparatuses<sup>16</sup> using a synchrotron-radiation apparatus of a reduced size, such that ISI's and super ISI's have imprinted circuit patterns.

Primarily described above were developments in technologies of superconductive wires and advances in the technology from the research stage to that of practical application. The fact that superconductive technologies, which had been built up in the sector of high-energy physics, bore fruit spectacularly as the NMR-CT apparatus must have secured a position for superconductive materials as industrial materials.

The superconductive material, nevertheless, still must depend on liquid helium as the cooling medium and, hence, hope for a better value of the critical temperature will grow more intense in the coming years. Although there are a number of bright prospects in connection with the improvement of existing substances and exploration of new substances, the time may have arrived when targets for development of superconductive materials have to be selected for a particular range of applications. For example, the home electric appliance sector may need development of a substance that is capable of exclusively raising the critical temperature of superconductive materials, and which is indispensable for the development of the Josephson device, the semiconductor

of the next generation and, hence, of great significance. On the other hand, in the heavy electric machinery sector, the development of materials for superhigh intensity of magnetic field and that of a conductor of superlow AC loss may be among the major targets involved.

#### FOOTNOTES

1. Bardeen, J., Cooper, L.N., and Schrieffer, J.R., PHYSICS REVIEW 106 (1957) 162; 108 (1957) p 1175.
2. Tanaka; MATERIAL, No 6, (1984) p 56.
3. Tanaka, "Technology Forecast Series," Vol 5, "New Materials Edition," Nippon Business Report (1985) p 53.
4. Suenaga, M. and Ralis, K.M., JOURNAL OF APPLIED PHYSICS, 40 (1969) p 4457.
5. Tanaka, Y., et al., 2nd U.S.-Japan Workshop on HFSM for Fusion (1983).
6. Ekin, J.W., "IEEE Trans.," MAG-17 (1981) p 658.
7. Hlasnik, I., JOURNAL DE PHYSIQUE, Tome 45 (1984) CI-459.
8. Dubots, P., et al., JOURNAL DE PHYSIQUE, Tome 45 (1984) CI-467, MT-8, Grenoble, France.
9. Tanaka, Y., et al., "IEEE Trans. on Nuclear Science" (1985).
10. Orr, J.R., "IEEE Trans. on Nuclear Science," NS-30 (1983) p 1967.
11. Noto, T., et al., MT-9, Zurich, Switzerland (1985).
12. Williams, J.E.C., et al., "Rev. Sci. Instrum.," 52-5 (1981) p 649.
13. Veccecy, G., "IEEE Trans. Mag.," MAG-17-5 (1981) p 2324.
14. Research Institute for Future Engineering, "Investigation and Research on the Application of Superconductivity and Related Technologies," Mar 1984.
15. San-ne, et al., "Cryogenics," 17-3 (1982).
16. Isobe and Suzuki, "Industrial Material," Vol 33, No 5 (1985) p 10.

## Super Heat-Resistant Materials

Tokyo KOGYO ZAIRYO in Japanese Oct 85 pp 34-39

[Article by Hiromitsu Tanaka, member of the General Research Institute of Toshiba Corp.]

[Text] There is growing demand for a major advance in the performance of materials of superhigh resistance to heat because of rising thermal efficiency of energy-related machines and equipment and a resulting rising temperature at which these machines and equipment are operated. Meanwhile, with the recent emergence of some ceramics which display superior mechanical performance even at high temperatures, the concept of super heat-resistant material has begun expanding into the domain of ceramics from that of metal alloys. This article concerns a study of the features of both materials in present stages of development, pointing toward future applicable technologies.

### Features of Materials and Improvements in Related Technologies

#### 1. Super Heat-Resistant Alloys

Figure 1 presents a forecast for the development of super heat-resistant alloys made some years ago in connection with the blade of the gas turbine. The predictions have generally proved true up to 1985, although these predictions concerned facts of the past. This implies that the technologies for heat resistance of alloys based on alloy design technologies have advanced and matured, thereby making it possible to control alloy compositions to an extremely high degree. Table 1, for example, shows the composition of IN 738, the representative nickel-based alloy super-resistant to heat, as compared with SUS 304, which is also a typical stainless steel, and is a conventional alloy. It is apparent that the former is far more complex and has a far greater number of metals added than the latter.

Where nickel-based alloys super-resistant to heat are concerned, three methods, are available for increasing their strength at high temperatures. One method is the reinforcement of the alloy matrix itself by admixing high melting metals like W, Mo, Ta, and Nb. Another is fine deposits referred to as the  $\gamma$ 'phase, which are interspersed in the alloy and increase its resistance to the deformation due to external forces. This method, though the most effective of all for reinforcing nickel-based alloys, makes the alloy fragile if the quantity of the deposits formed is excessive. Therefore, its quantity in the alloy has to be optimized. Since the  $\gamma$ 'phase is an inter-metallic compound of Ti, Al, and Ni, the quantity of these metal elements must be the control factor. Lastly, reinforcement of the grain boundaries is effected by adding C, B, Hf, Zr, etc. since grain boundaries sometimes dictate the destruction of metallic materials at high temperature. The heat-resistant metal materials must also have not only high strength at high temperatures, but also high resistance to oxidation and corrosion. Cr is added to the alloy for this purpose. These additions of various elements for various purposes turn the alloy into a multi-elementary one on one hand. On the other, one special composition of metals adapted for one special purpose is chosen, since it is impossible to get the best of all these added elements in one alloy.

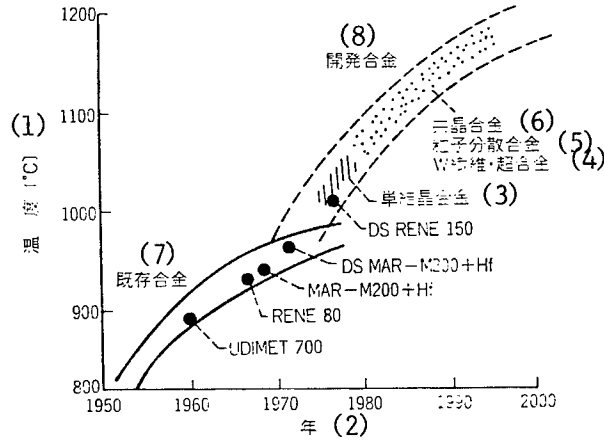

Figure 1. Forecast for Development of Heat-Resistant Materials of Turbine Blades

Key:

1. Temperature
2. Year
3. Single crystal alloy
4. Tungsten (W) fiber super alloy
5. [Oxide] particle-dispersion alloy
6. Eutectic alloy
7. Existing alloys
8. Alloys under development

(1) 合金成分	C	Ni	Cr	Co	Al	Ti	Mo	W	Ta	Nb	Fe	B	Zr
SUS304	0.17	8	18	—	—	—	—	—	—	—	(2)	残	—
IN738	0.05	残	16	8.5	3.4	3.4	1.8	2.6	1.8	0.9	0.5	0.01	0.1

Table 1. Composition Comparison of a Conventional Alloy, SUS 304, With a Superheat-Resistant Alloy, IN 738

Key:

1. Composition of alloy
2. Trace

Table 2 presents compositions and characters of frequently used alloys of superhigh resistance to heat for comparison.

As referred to above, the development of alloys of superhigh resistance to heat has approached perfection on the basis of alloy design technologies. Nevertheless, new methods have been introduced for further improvement of the performance of the alloy. These methods include a technology for the control of crystals, reinforcement of alloys by the dispersion of oxide particles (ODS) and fiber-reinforced alloys which follow (refer to Figure 1).

### (1) Technologies for the Control of Crystals

Destruction related to the grain boundary of crystals can be effectively reduced by eliminating the grain boundaries which are at right angles to the direction of the force of stress applied. To this end, a method has been developed for allowing a columnar growth of crystals in the direction of stress--unidirectional solidification--and, furthermore, a technology for growing single crystals with no grain boundaries in any direction. The reduction of unnecessary grain boundaries has the additional advantage that the addition of grain-boundary reinforcing elements, which are indispensable for usual alloys, is made unnecessary and a reduction in the melting point produced by the metal addition has been eliminated.

### (2) Alloys Reinforced by the Dispersion of Oxide Particles (ODS)

As referred to above, the dispersion of the  $\gamma$  'phase serves to reinforce nickel-based alloys. The  $\gamma$  'phase involved is produced by a metallographical method.

The ODS method described here disperses fine particles in the alloy artificially, aiming to produce similar effects. Furthermore, it has an advantage over the  $\gamma$  'phase method in that the former allows the reinforcing effect to hold on because it involves the use of fine particles of oxides that are stable even at high temperatures while the  $\alpha$  'phase is absolutely unstable at high temperatures, as is evident from the process of its formation.

### (3) Fiber-Reinforced Alloys

The principle of reinforcing basic materials by means of a fiber of high strength, as exemplified by reinforced plastics, holds true also in the sector of materials of superhigh resistance to heat. Nevertheless, it is not necessarily easy to find a fiber that works at high temperatures and to devise a method for molding the fiber. Prospective fibers available for this purpose are those of inorganic substances and heat-resistant metals. The former, however, is confronting a number of problems in adapting itself to base materials, and has yet to find practical applications. One difficulty for the latter, which is represented by W and Mo, is poor resistance to oxidation of these materials. Learning how to bury and seal these in a highly anti-oxidant base material is the key to its solution. It is also necessary to devise a method for preventing the reaction between the reinforcing fiber and the matrix alloy after long hours of exposure of the composite metal to high

(1) 成 分 (%)	
ALLOY	C Mn Si Cr Ni Co MOW Cb Ti Al B Zr Fe 他
Alloy713LC	.05 12.0 Bal 4.5 2.0 .6 5.9 .01 .1
B-1900	.1 .2 .25 8.0 Bal10.06.0 .1 .11.0 6.0 .015 .08 .354.37a
Hastelloy X	.1 1.01.0 22.0 Bal 1.59.0 .6 .15 5.008 18.50.90c
IN-100	.18 10.0 Bal15.03.0 4.7 5.5 .014 .06 1.0'
IN-738	.17 .2 .3 16 Bal 8.51.75 2.6 .93.4 3.4 .01 .1 .5 1.751a
MA-754	.05 20 78.5 .5 .3 .61203
Alloy718	.04 .2 .2 18.552.5 3.0 5.1 .9 .5 18.5.20c
Mar-M200	.15 9.0 Bal10.010.0 2.6 1.0 .005
Udimet700	.07 15 Bal18.5 5.0 3.5 4.4 .025
WaspalloyA	.07 .5 .5 19.5 Bal13.5 4.0 3.0 1.4 .006 .09 2.0.10c
FSX-414	.25 1.01.0 29.510.5 Bal 7.0 .012 2.0
X-40	.5 .5 .5 25 10 Bal 7.5 1.5
Mar-M509	.6 .1 .1 21.510 Bal 7.0 .2 .01 .5 1.03.57a
S-816	.38 1.2 .4 20 20 Bal 4.0 4.0 4.0 4
A-286	.05 1.4 .4 15 26 1.25 2.15 .2 .003 Bal.03V
(2) ラフチャ-強度 (1,000ksi)	
ALLOY	1,200°F 1,500°F 1,800°F 2,000°F
	100hr 1,000hr 100hr 1,000hr 100hr 1,000hr 100hr 1,000hr
Alloy713LC	— — 62 47 20 15 — —
B-1900	— — 73 55 26 15.4 — —
Hastelloy X	48 34 14 10 3.7 2.1 1.2 0.6
IN-100	— — 73 55 25 15 9.0 —
IN-738	— — 66 52 19 12 — —
MA-754	41.2 37.2 27 24 19.7 18.7 14.8 13.6
Alloy718	102 86 — — — — —
Mar-M200	— — 76 60 27 19 11 6.5
Udimet700	— — 58 43 16 8 — —
WaspalloyA	108 88 40 25.5 6.8 — — —
FSX-414	— — 22 17 8.0 5.0 3.1 —
X-40	57 49 26 20 11 8.0 4.0 —
Mar-M509	— — 39 33 17 13 8.0 5.5
S-816	60 46 25 18 — — — —
A-286	61 46 35 21 13 8 — —
	1,350°F 1,500°F

Table 2. Property and Composition of Super[heat-Resistant] Alloys

Key:

1. Composition
2. Rupture strength

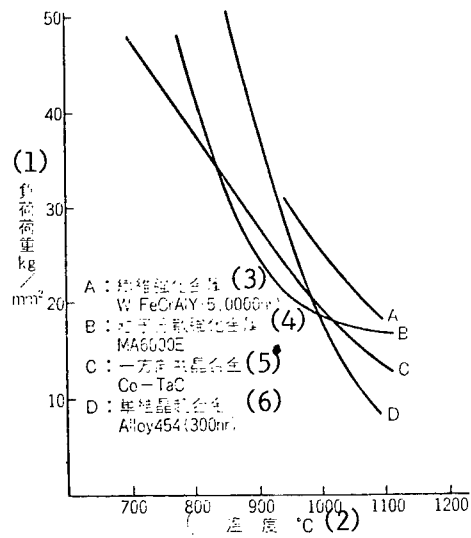

Figure 2. Rupture Strength After 1,000 Hours of Creep for Various Types of Superheat-Resistant Alloys (Time Differing for Some of the Alloys)

Key:

1. Weight of the load
2. Temperature
3. Fiber-reinforced metal
4. Particle dispersion reinforced metal
5. Unidirectional eutectic alloy
6. Single-crystal alloy

temperatures. For example, where a heat-resistant metal fiber such as W or Mo is combined with a nickel-based alloy--the usual base of super heat-resistant materials--the reaction between the two components is excessive and the product is not practically applicable. Fe-based alloys, therefore, are chosen, which react less intensively with the fiber.

In addition to the above two, a method for the control of crystal growth has been used for processing a fiber-reinforced alloy. The alloy, which is referred to as a unidirectional-solidification eutectic alloy, has crystals of an intermetallic compound, which is of a superior performance and of a fiber or plate form, grown unidirectionally in itself. The crystal is excellent in its adaptability to the base metal since it is grown metallographically, even though the composition of metals may be limited in kind.

Figure 2 shows a plot for the performance of super heat-resistant alloys of which some have already found practical applications but most are under development.

## 2. Heat-Resistant Ceramics

Since ceramics are a product of burning clay, "heat resistant" may not be an appropriate adjective. Now that ceramics have become available for structural materials at high temperature, however, the adjective "heat resistant" must imply more than simple heat resistance.

Though a large number of ceramic kinds have been developed, the ceramics available for high-temperature structural materials are limited largely to  $\text{Si}_3\text{N}_4$ ,  $\text{SiC}$ , and  $\text{SiAlON}$  at present. Figure 3 gives high-temperature characteristics of heat-resistant ceramics.<sup>1</sup> These characteristically have properties varying, in great measure, with the method of manufacture, even if chemical compositions are identical.

Table 3 presents the methods of manufacture of heat-resistant ceramics and their characteristics,<sup>2</sup> showing the influence of the microscopic structure of molded bodies on their properties. Each of the manufacturing methods, meanwhile, requires different additives or sintering agents, which also lend themselves to varying properties of the product.

The inherent property of heat-resistant ceramic material is fragility, with no capacity for plastic deformation like that of metals. Data for the strength of heat-resistant ceramics generally involve results of the bending test<sup>3</sup> (see Table 4), the value of which, however, represents an average of values obtained from test pieces produced by careful machining. In actual practice, the data for assessment exhibits substantial variance in value: because of its fragility, a ceramic product has its performance reduced by the presence of a minor fault, and the probability of this presence of faults in products produces a large variance in the strength of the product. A statistical method of expression such as the Weibull distribution is sometimes used. Because of the presence of large variances in the value of its strength, heat-resistant ceramics have yet to find a direct application as a structural material even though they have attained a substantial level in this regard. A reduction of potential defects, by any means, is an important objective in the

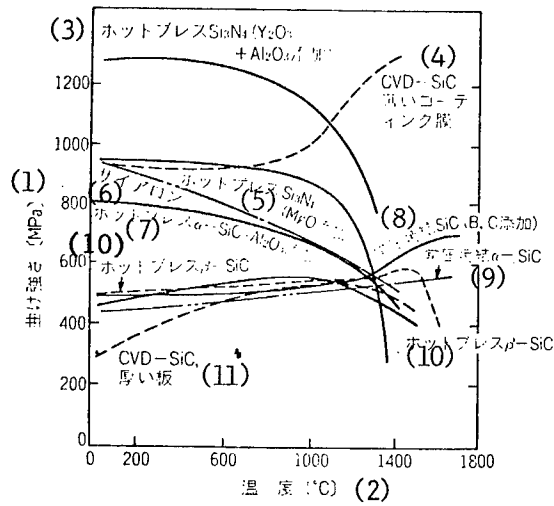

Figure 3. Bending Strength at High Temperatures of Fine Ceramics

Key:

1. Bending strength
2. Temperature
3. Hot press  $\text{Si}_3\text{N}_4$  ( $\text{Y}_2\text{O}_3$  +  $\text{Al}_2\text{O}_3$  added)
4. CVD [chemical vapor deposition] SiC, thin coating in film
5. Hot press  $\text{Si}_3\text{N}_4$  (MgO added)
6. Sialon
7. Hot press  $\alpha$ -SiC ( $\text{Al}_2\text{O}_3$  added)
8. Normal pressure sintering SiC (B and C added)
9. Normal pressure sintering  $\alpha$ -SiC
10. Hot press  $\beta$ -SiC
11. CVD-SiC, thick plate

(1) 材料	(2) 焼結法	(3) 特徴
Si <sub>3</sub> N <sub>4</sub>	(4) 反応焼結	多孔質、低強度だが複雑形状の成形品が可能 (9)
	(5) ホットプレス	高密度、高強度、しかし一般に単純形状しかできない (10)
SiC	(6) 常圧焼結	多孔質あるいは高密度、低強度だが複雑形状の成形品が可能 (11)
	(7) 自己焼結 (Si注入法も含む)	一般に多孔質、高密度なものではSiを含む、複雑形状の成形品が可能 (12)
Sialon	(8) CVD	一般に表面コーティング、高純度・高密度の皮膜形成には好適だが大型成形品は困難 (13)

Table 3. Heat-Resistant Ceramic Material and Manufacture Methods

Key:

1. Material
2. Method of sintering
3. Characteristics
4. Reaction sintering
5. Hot press
6. Normal pressure or atmospheric sintering
7. Self-sintering, including Si injection method
8. CVD
9. The method provides a product which, though porous and of low strength, is of complex shapes.
10. The method provides a product which is compact and of high strength, though of simple shape in general.
11. The product is either porous or compact and can be of complex shapes though of low strength.
12. The products are porous except those containing Si, which are compact, and can be of complex shapes.
13. The method is adapted generally to surface coating and to the formation of film of high purity and high compactness, but not to molding large objects.

	K <sub>IC</sub> (MN/m <sup>3/2</sup> )	(1) 強度 (MN/m <sup>2</sup> )*
(2) ホットプレス Si <sub>3</sub> N <sub>4</sub>	4.7	870
"    (1,000°C)**	5.0	810
"    (1,200°C)	5.8	670
(3) 常圧焼結 SiC	4.2	470
"    (1,000°C)	4.5	560
"    (1,200°C)	4.6	590
(4) ホットプレス Al <sub>2</sub> O <sub>3</sub>	5.0	600
"    (ZrO <sub>2</sub> 添加)	17.0	1,150
(5) 炭素鋼(低強度)	210以上	235
(6) マルエージ鋼(300KSI級)	93	1,670
(7) アルミ合金(2024-T3)	34	392

(8) \*セラミックスは曲げ強度、金属は降伏応力を示す  
(9) \*\*温度の指示のないものは室温値

Table 4. Fracture Toughness and Strength of Ceramics and Metals

Key:

1. Strength
2. Hot press Si<sub>3</sub>N<sub>4</sub>
3. Normal pressure or atmospheric sintering SiC
4. Hot press Al<sub>2</sub>O<sub>3</sub> (ZrO<sub>2</sub> added)
5. Carbon steel of low strength
6. Marage steel
7. Aluminum alloy
8. Bending strength for ceramics and yield stress for metals are provided.
9. At room temperature unless otherwise indicated

development of existing heat-resistant ceramics. Developmental efforts in  $\text{Si}_3\text{N}_4$ , meanwhile, have afforded a powder where the size and shape of particles are very uniform. This permits a reduction in the degree of dispersion of the ceramic products in comparison with the other heat-resistant ceramics.

### Application Technologies

The development of super heat-resistant materials is expected to go on in the coming years with a view to further improve their performances. It is likewise important that technologies for an effective application of these materials be explored. Though there are a number of technologies, each adapted to one application, a few that are commonly available for every objective are described below.

#### 1. Joining Technologies

Super heat-resistant materials, by nature, have very poor processability and, when used as component materials, have to be molded in the intended shape at the initial stage of their manufacture. Metallic materials are molded by precision casting and ceramic materials by a combination of the methods of injection molding and normal-pressure sintering. However, with increasing sophistication of the functions of mechanical systems and the shape of their components, these technologies are no longer able to meet requirements satisfactorily. Joining technologies emerged dominantly among component-manufacturing technologies.

##### (1) Joining of Super Heat-Resistant Alloys

Welding and soldering have been conventionally available for firmly joining metals. Neither of them, however, ensures sufficient strength at high temperatures as far as super heat-resistant alloys are concerned. Welding causes fusion of the alloy matrix and fails to keep the metal structure at desired conditions. With soldering, the properties of the solder dictate consequent performances. It becomes necessary, therefore, to develop a method of joining which permits a joining site strength equivalent to that of the alloy itself.

A method, referred to as diffusion joining has been adapted to this objective and has produced favorable results. Diffusion joining is made up of solid-phase diffusion and liquid-phase diffusion joining.

##### i) Solid-Phase Diffusion Joining

Pieces to be jointed are contacted and subjected to pressure at high temperatures to allow metal atoms to diffuse between the pieces. This method is simple and of high joint efficiency, but has the disadvantage that it often is not capable of affording sufficient precision in size due to the application of pressure. Also, the joining is not reliable in cases where the surface to be joined has a complex shape.

## ii) Liquid-Phase Diffusion Joining

Though similar to a soldering, this method of joining leaves no solder at the site of joining after the joining has been effected, but turns the structure of the site, characteristically, into the one identical with the alloy metal. In other words, the method uses a solder which is similar to the alloy metal in composition, but has some elements of high diffusion speed added, effecting a fall in melting point. Joining is accomplished by the formation of a temporary liquid phase at the joining site, which is subsequently made identical in structure with the alloy metal by heat treatment. The principle of this method is presented in Figure 4. If super heat-resistant alloys of highly sophisticated alloy design are to be joined by this method, the use of a solder of sufficiently adjusted composition has to be combined with proper application of the heat treatment. Figure 5 presents the relationship between the joint efficiency and solders applied for the liquid-phase diffusion joining as tested on Mar M247,<sup>4</sup> super heat-resistant alloys of the highest strength currently commercially available.

### (2) Joining Heat-Resistant Ceramics With Metal Ceramics

Joining of heat-resistant ceramics with metal ceramics is not yet reliable enough for heat-resistant structural components of a system to be made up exclusively of ceramics. The prevailing method for this purpose, is a hybrid method in which heat-resistant ceramics are used at sites where they are indispensable and metals are in the remaining portions. The method of joining the two materials must play a decisive role here. Nevertheless, the heat resistant ceramics described above are much more stable than conventional oxide-type ceramics and, hence, their joining faces great difficulties. One potent method recently developed is soldering using an activated metal solder. The solder, which is made up of the usual silver or copper with titanium zirconium and other active metals added, accomplishes joining on the basis of a ceramic reaction.

Figure 6 presents the joining strength accomplished by this method between  $\text{Si}_3\text{N}_4$  and steel.<sup>5</sup> Up to a temperature of 400 degrees C, the method is practical, but not satisfactory in strength beyond that temperature. In joining a ceramic with a metal, not only is the reaction between the two materials enhanced, but also a reduction of the thermal stress produced by the difference in thermal expansion coefficients between them is significant. For the latter purpose, the plastic deformation of soft metals is being used, which, however, has the adverse effect of bringing down the joining strength at high temperatures. Increasing the strength at the joint will be a major problem in the coming years.

## 2. Coating Technology

It is hardly possible to find all the required properties of super heat-resistant materials to be embodied in single materials. One approach to the problem, therefore, is to aim at the improvement of a material exclusively and comprehensively in strength on the one hand, and to depend on anticorrosive coating for other functions such as resistance to oxidation and to corrosion.

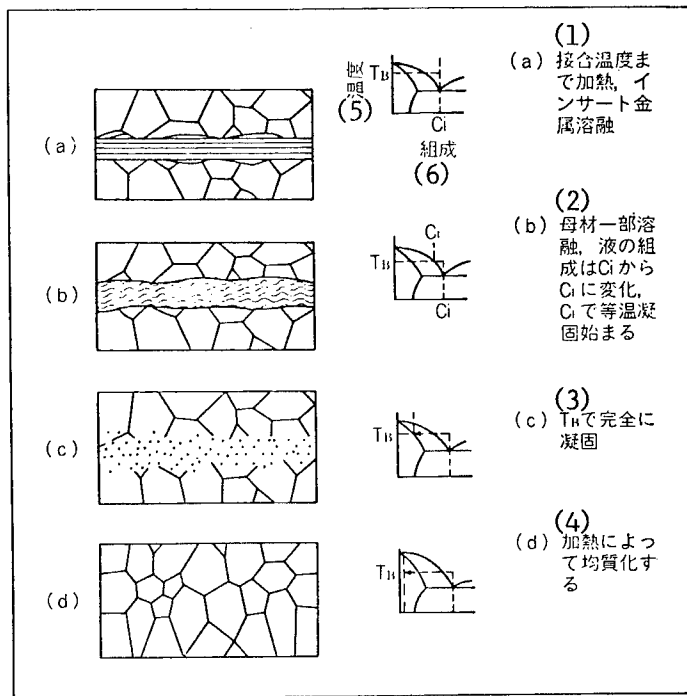
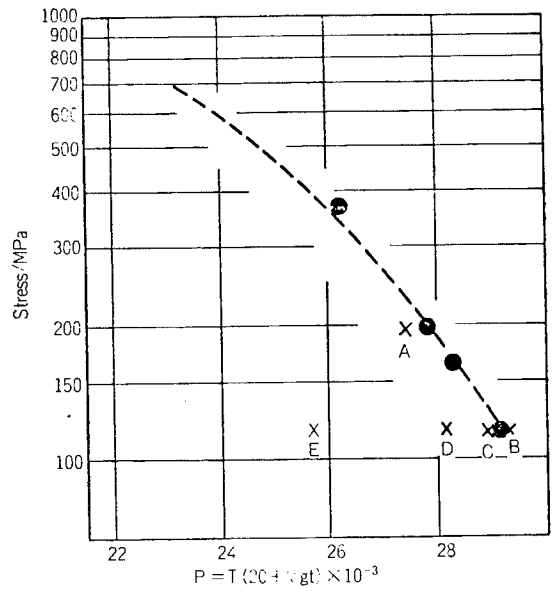

Figure 4. Principle of Liquid-Phase Diffusion Bonding

Key:

1. Heat is applied in order to raise the temperature to that of bonding, in-site melting of the metal.
2. Part of the matrix of the metal has fused and the composition of the liquid changed from  $C_i$  to  $C_1$  at which solidification at a constant temperature begins to proceed.
3. Solidification is complete at  $T_B$
4. The material is made uniform in quality by application of heat.
5. Temperature
6. Composition



Filler Metal	C	Cr	Co	Ni	W	Al	B	Ta	Other
A	0.03	8.3	10.9	Bal.	4.5	3.2	2.2	3.4	
B	0.01	8.8	10.8	"	3.9	3.0	2.5	3.0	
C		8.7	11.3	"	6.6	3.8	3.8	2.7	
D	0.03	8.5	10.5	"	4.0	3.2	2.3	3.5	H <sub>2</sub> 4 Zn 1
E		15.2		"			4.0		

Figure 5. Relationship of the Strength of Bonding (Joint Efficiency) of Mar M247 to Soldering Materials (Filler Metals)

A heat shielding coating is also available as an effective means in connection with high-temperature components equipped with a cooling system.

#### 1) Anticorrosive Coating

Anticorrosive coating has, to date, been accomplished largely by diffusion permeation, a chemical method also referred to as pack coating. This involves diffusion of highly anticorrosive aluminum and chromium over the surface of the metal to be coated. The method has undergone transition from a single element to a multielement system, and has come to be coupled with chemical or physical vapor deposition.

Plasma spray coating, meanwhile, has a very high degree of freedom in control of the compositions of metals and has recently been in the spotlight from the viewpoint of formation of the layer of a coating involving multiple elements. A low-pressure plasma-spray coating, in particular, brings about the coating in a vessel of reduced pressure and provides compact coating of superior microscopic structure. It thus can play a major role in the future in the sector of anticorrosion coating.

Anticorrosive coating is available not just for super heat-resistant materials but also for heat-resistant ceramics since even these ceramics, where the non-oxide type is concerned, have their surfaces sometimes oxidized slightly at high temperatures. A compact ceramic coating affords them better resistance to oxidation.

#### (2) Heat-Insulation Coating

The gas turbine, as a representative of machines and equipment that are subjected to super-high temperatures, has to be operated at temperatures exceeding the tolerable limit of the super heat-resistant alloys used therein. These alloys, therefore, need to be cooled such that a proper difference in temperature be sustained between the alloy and the turbine and that the temperature of the alloy be held below its limit. The cooling of the component alloy, nevertheless, acts adversely to the operating temperature of the turbine, which must be raised as high as possible if the operating efficiency of the turbine is to be improved. The cooling of the component alloys, therefore, has to be limited to the maximum possible extent. Heat-insulation coating has been developed for this purpose: the surface of the alloy, which is to be subjected to high temperatures, and to which cooling is to be applied, is coated with a ceramic of low heat conductance by means of plasma-spray coating such that the flow of heat to the cooling media is obstructed. Figure 7 shows the improved efficiency of a power generation system to be gained by the application of heat-insulation coating. This heat-insulation coating has already found practical applications in the combustion chamber of the turbine and also in the turbine blades of some airplane engines. It has the prospect of increasing applications in the coming years.

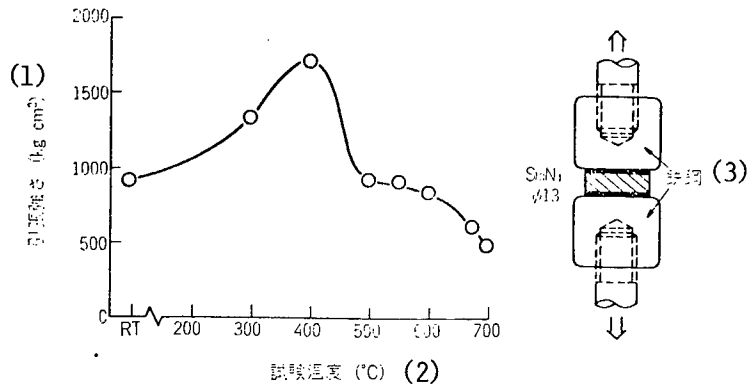

Figure 6. Plot of Tensile Strength Against Testing Temperatures for  $\text{Si}_3\text{N}_4$ , an Agent for Bonding Steel Objects

Key:

1. Tensile strength
2. Testing temperature
3. Steel

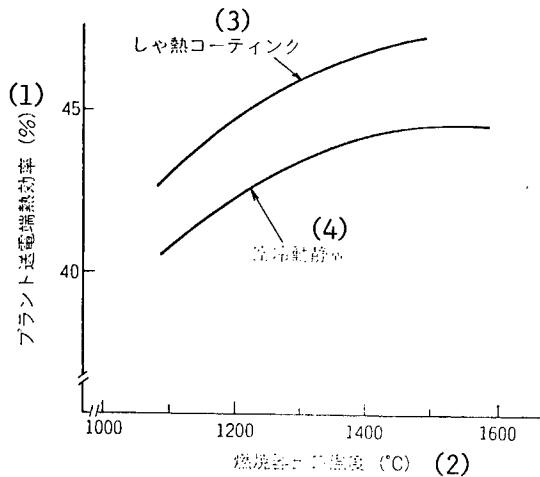

Figure 7. Effect of Heat-Insulation Coating on the Efficiency of Power Plants

Key:

1. Thermal efficiency at the power transmission terminal of the power plant
2. Temperature at outlet of the combustion chamber
3. Heat insulation coating
4. Air-cooled mobile-stationary blade

Super heat-resistant materials are required to have more diverse properties than other structural materials. Their development extends existing technologies as shown in Figure 1, and must be pushed ahead on the basis of their features. It is unrealistic to expect the emergence of a new material by a sudden mutation-like change.

#### FOOTNOTES

1. Suzuki, Hiroshige, "A Collection of Drafts for Lectures at Meetings of the Japan Material Science Society," (1982) p 16.
2. Shimada, Masahiko, Koizumi, Mitsue, "Industrial Rare Metals," 73, (1980) p 29.
3. Abe, Hiroshi, "Promising Advanced Materials," The Industrial Survey Association, 1982, p 160.
4. Nakahashi, M., et al., "Superalloys (1985) Japan-U.S. Seminar," (1985), p 239.
5. Shirokane, Makoto, "A Collection of the Summaries of Lectures at Meetings of the Japan Metallurgy Society," (1985.4) p 233.

#### Hydrogen Storage Alloys

Tokyo KOGYO ZAIRYO in Japanese Oct 85 pp 40-47

[Article by Tsutomu Iwaki of Matsushita Electric Industry Co., Ltd.]

[Text] Much time has passed since hydrogen was spotlighted as a clean energy, i.e., energy involving no pollution problems. Though the problem of hydrogen energy has yet to be taken up as a fuel of extensive applications because of the supply-demand relations of petroleum and various other energy resources at this juncture, the problem of energy needs to be evaluated from a long-term viewpoint. Research on hydrogen storage alloys which permit storage and transportation of hydrogen for fuel use have been continuing steadfastly. Also conceivable for these alloys are many other applications, including refining of hydrogen, heat pumps, batteries, catalysts, chemical engines, etc. Research on these problems is moving ahead in parallel. This paper deals with the characteristics of hydrogen storage alloys for the above applications and the future development of these applications.

#### Characteristics of Hydrogen Storage Alloys

##### 1. Nature of Hydrogen Storage Alloys

Among the metal hydrides produced by the reaction of hydrogen with metals, those that are capable of repeating reciprocally the absorption and release of hydrogen are referred to as hydrogen storage alloys. Hydrogen, upon contact with a metal, is absorbed on its surface, and after having decomposed into hydrogen atoms, H, penetrates into the crystal lattice of the metal and

occupies intervening spaces between the metal atoms, i.e., inter-lattice or interstitial positions. When the pressure of the hydrogen is raised gradually, hydrogen atoms continue to penetrate the metal until it has been saturated with the atoms, thereby forming a metal hydride.<sup>1</sup> The release of hydrogen is the reverse phenomenon of this.

The absorption of hydrogen, which is exothermic, is represented generally as

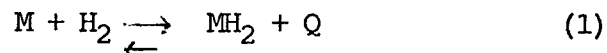

Among the typical hydrogen absorption alloys are: LaNi<sub>5</sub> and MnNi<sub>5</sub> for the rare earth group; TiFe, TiCo, and TiMn for the titanium series; the calcium and magnesium series; and also the zirconium and beryllium series.<sup>2</sup>

## 2. Absorption and Release of Hydrogen

The most important property required of the hydrogen storage alloys is a large capacity for the absorption and release of hydrogen. Table 1 presents the capacities for the absorption of hydrogen of some alloys which have been developed to date. These values vary to some extent with sources, LaNi<sub>5</sub>, for example, absorbs 1.4 percent by weight of hydrogen, which is equivalent to around 160 milliliters per gram under normal conditions. Whereas the values for most of the alloys are at the 1 percent level, those for the magnesium series are distinctly larger. In terms of handling the reaction involved, meanwhile, the pressures of the dissociation of hydrogen of several atmospheres (atms) at normal temperatures are favored, and, the dissociation pressure with corresponding reaction temperatures for each alloy is added in Table 1. The reaction temperature for magnesium seems to be excessively high, though the adequacy of the temperature must of course depend on the application.

Another property required is a high speed in the reaction for the absorption and liberation of hydrogen. However, the speeds of the reaction even for two identical materials can vary depending on the quantities and particle shapes of the material, the temperature and pressure of the reaction, the vessel of the material, conditions of packing of the material in the vessel, etc. Thus, no criteria for the evaluation of these values have yet been set up. An example for these values is presented for TiMn<sub>1.5</sub> in two plots of Figure 1. One is a plot of the speed of the absorption of hydrogen for different temperatures and the second is that for the speed of the liberation of hydrogen for different pressures. They indicate that a temperature of 20 degrees C is the optimum for absorption, and a pressure of 25 atms for liberation.<sup>3</sup>

Where LaNi<sub>5</sub> is concerned, nickel seems to play, in theory, a major role in the rate of absorption of hydrogen. The surface of this alloy is filled with such atoms as Ni, La<sub>2</sub>O<sub>3</sub>, and La(OH)<sub>3</sub>. Hydrogen atoms, nevertheless, are chemically absorbed exclusively by nickel-atom layers. Subsequently, they are turned into an atomic state by the action of La<sub>2</sub>O<sub>3</sub> and La(OH)<sub>3</sub>. Finally, they settle in the inter-lattice space of the LaNi<sub>5</sub>. If the nickel is replaced by Fe, Co, or Mn, the rate of absorption is Mn, Fe, Co, Ni in that order. The surface of

(1) 水素貯蔵合金	(2) 水素含有率 (wt%)	(3) 解離圧 (atm)
MgH <sub>2</sub>	7.6	1(290°C)
Mg <sub>2</sub> NiH <sub>4.0</sub>	3.6	1(250°C)
Mg <sub>2</sub> CuH	2.7	1(239°C)
CaNi <sub>5</sub> H <sub>4.0</sub>	1.2	0.4( 30°C)
LaNi <sub>5</sub> H <sub>6.0</sub>	1.4	4( 50°C)
MmNi <sub>5</sub> H <sub>6.3</sub>	1.4	34( 50°C)
Mm <sub>0.5</sub> Ca <sub>0.5</sub> Ni <sub>5</sub> H <sub>5.0</sub>	1.3	19( 50°C)
MmNi <sub>4.5</sub> Mn <sub>0.5</sub> H <sub>6.6</sub>	1.5	4( 50°C)
MmNi <sub>2.5</sub> Co <sub>2.5</sub> H <sub>2.5</sub>	1.2	6( 50°C)
MmNi <sub>4.5</sub> Al <sub>0.5</sub> H <sub>4.9</sub>	1.2	5( 50°C)
Mm <sub>0.5</sub> Ca <sub>0.5</sub> Ni <sub>2.5</sub> H <sub>4.5</sub>	1.1	9( 50°C)
MmNi <sub>4.5</sub> Mn <sub>0.5</sub> Zr <sub>0.05</sub> H <sub>7.0</sub>	1.6	4( 50°C)
LaNi <sub>4.6</sub> Al <sub>0.4</sub> H <sub>5.5</sub>	1.3	2( 80°C)
TiFeH <sub>1.9</sub>	1.8	10( 50°C)
TiFe <sub>0.85</sub> Mn <sub>0.15</sub> H <sub>1.9</sub>	1.8	5( 40°C)
TiCo <sub>0.5</sub> Mn <sub>0.5</sub> H <sub>1.7</sub>	1.6	1( 90°C)
TiMn <sub>1.5</sub> H <sub>2.47</sub>	1.8	5~8( 20°C)
Ti <sub>0.8</sub> Zr <sub>0.2</sub> Mn <sub>1.8</sub> Mo <sub>0.2</sub> H <sub>3.0</sub>	1.7	2~6( 20°C)
Ti <sub>0.5</sub> Zr <sub>0.1</sub> Mn <sub>1.4</sub> Vo <sub>0.2</sub> Cr <sub>0.1</sub> H <sub>3.2</sub>	2.1	8~9( 20°C)
Ti <sub>0.8</sub> Zr <sub>0.2</sub> Cr <sub>0.8</sub> Mn <sub>1.2</sub> H <sub>2.0</sub>	1.8	5( 20°C)
Ti <sub>1.2</sub> Cr <sub>1.2</sub> Mn <sub>0.8</sub> H <sub>3.2</sub>	2.0	7( 10°C)
Ti <sub>1.2</sub> CrMnH <sub>3.1</sub>	2.1	5(-10°C)
Ti <sub>0.95</sub> Fe <sub>0.05</sub> Zr <sub>0.04</sub> Nb <sub>0.04</sub> H	1.8	1.8( 30°C)
Ti <sub>0.5</sub> Zr <sub>0.5</sub> Fe <sub>0.2</sub> Mn <sub>0.5</sub> H <sub>1.5</sub>	1.0	3(150°C)
ZrMn <sub>2</sub> H <sub>3.0</sub>	1.7	1(210°C)

Table 1. Hydrogen Content and Hydrogen Dissociation Pressure for Various Types of Hydrogen Storage Alloys

Key:

1. Hydrogen storage alloys
2. Content of hydrogen
3. Dissociation pressure

the alloy of Mn and Ni are made up of a single element layer of Mn of thickness 20 Å and that of Ni of thickness 200 Å respectively. These layers dictate the rate of hydrogen absorption.<sup>1,4</sup>

In the alloy TiFe, meanwhile, clusters of iron atoms occur over the active surface of the alloy,<sup>5</sup> lend themselves to the formation of hydrogen atoms, and thus enhance hydrogen absorption. Where alloys in which β-Ti-phase and TiFe coexist, hydrogen atoms seem to press ahead through the interface between the two structures and hydridation to be facilitated with an increase of the presence of the oxide Fe<sub>7</sub>Ti<sub>10</sub>O<sub>3</sub>, according to one report.<sup>6</sup>

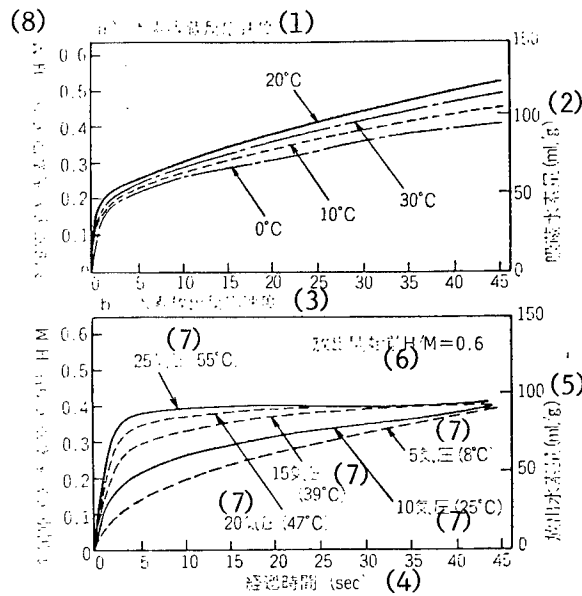

Figure 1. Speeds of Hydrogen Combining and Hydrogen Relinquishing Reactions for the Hydrid TiMn<sub>1.5</sub>

Key:

1. Speed of hydrogen combining reaction
2. Quantity of hydrogen combined
3. Speed of hydrogen relinquishing reaction
4. Time elapsed (in seconds)
5. Quantity of hydrogen relinquished
6. Prior to the start of hydrogen release
7. Atmospheres (atms)
8. Ratio of the number of atoms of hydrogen to that of metal

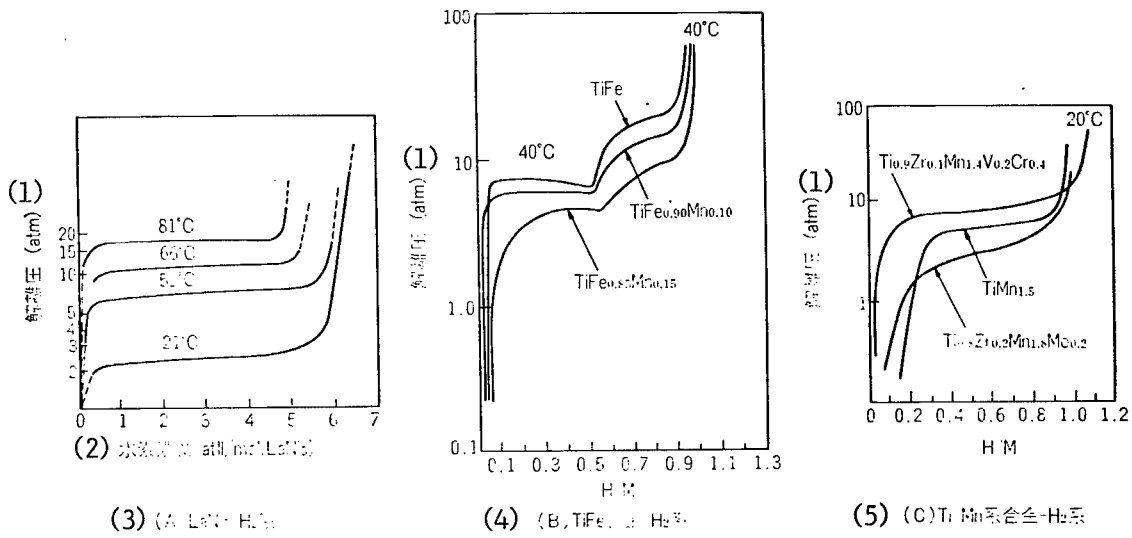

Figure 2. Plot of Equilibrium Hydrogen Pressure versus Composition Represented by Isothermic Curves for Various Types of Hydrogen Storage Alloys

Key:

1. Dissociation pressure
2. Hydrogen concentration
3. LaNi<sub>5</sub>-H<sub>2</sub> series
4. TiFe alloy-H<sub>2</sub> series
5. TiMn alloy-H<sub>2</sub> series

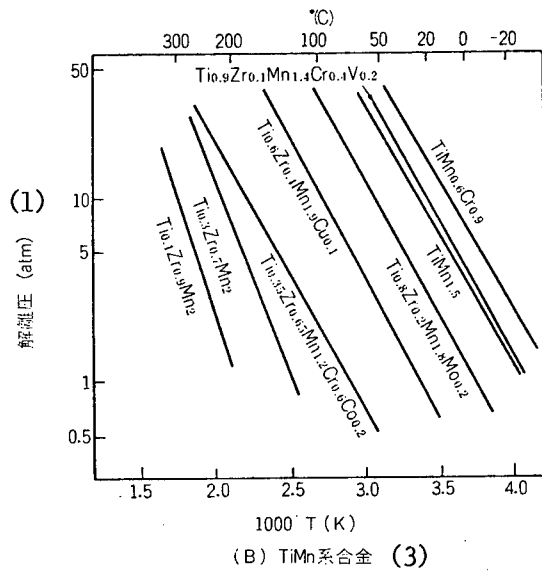
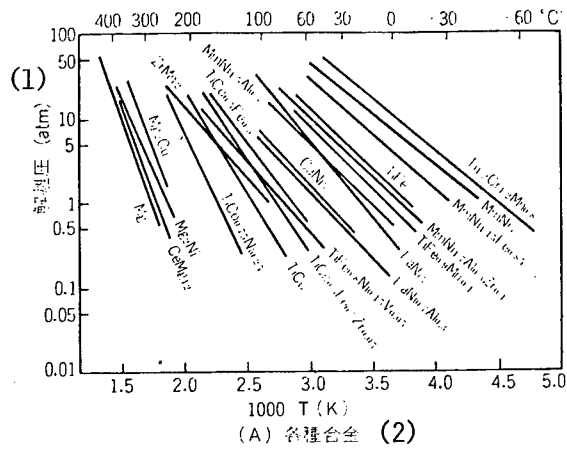

Figure 3. Dependence on Temperature of Hydrogen Dissociation Pressure for Various Types of Hydrogen-Storage Alloys

Key:

1. Dissociation pressure
2. Various alloys
3. TiMn series of alloys

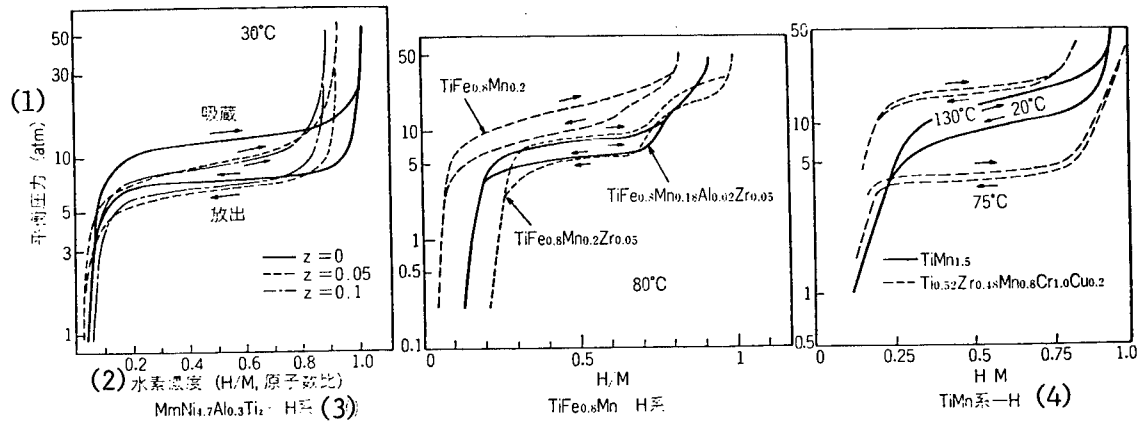

Figure 4. Plot of Equilibrium Pressure versus Hydride Composition at a Constant Temperature for Hydrogen Combining and Hydrogen Relinquishing Reactions

Key:

1. Equilibrium pressure
2. Hydrogen concentration (H/M or the ratio in the number of atoms)
3.  $\text{MmNi}_{4.7}\text{Al}_{0.3}\text{Ti}_2$ -H series
4. ----- series

### 3. P.C.T. Characteristics

When the reaction of hydrogen storage alloys is represented by a plot of the logarithm of its equilibrium pressure  $P$  as the ordinate, versus the hydride concentration  $C$  as the abscissa, isothermal lines  $T$  need to exhibit a plateau region. Figure 2 A presents a plateau region of high quality exhibited by  $\text{LaNi}_5$ , and Figure 2 B displays a two-stage plateau by  $\text{TiFe}$ . In the latter figure, the plateau at low pressure indicates the coexistence of a solid solution, wherein hydrogen dissolves in the alloy crystal, and the metal hydride  $\text{TiFeH}$ . The one at higher pressure, on the other hand, is produced by the coexistence of the metal hydrides  $\text{TiFeH}$  and  $\text{TiFeH}_2$ . In Figure 2 C, one can see that the  $\text{TiMn}$  series permits plateaus in a fairly wide temperature range providing the alloy has some variable elements added.

Let us consider the relationship between the dissociation pressure and the temperature in the above reaction. The reaction involving the formation of a metal hydride, i.e., the reaction of the formation of a metal hydride phase  $\text{MH}_y$  from a solid-solution phase  $\text{MH}_x$ , proceeds at a fixed pressure  $P_{\text{H}_2}$  in the plateau region and is given by:

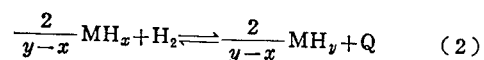

Assuming that changes of the standard formation free energy, the standard enthalpy, and the standard entropy, ( $\Delta G^\circ$ ,  $\Delta H^\circ$ , and  $\Delta S^\circ$ , respectively), are constant regardless of the temperature, the value of the  $P_{\text{H}_2}$  may be represented by:

$$\ln P_{\text{H}_2} = \frac{\Delta H^\circ}{RT} - \frac{\Delta S^\circ}{R} \quad (3)$$

where  $R$  denotes the gas constant and  $T$  the absolute temperature. The  $\ln P_{\text{H}_2}$ , therefore, relates linearly to  $1/T$ , to the slope  $\Delta H/R$ , and to the term  $\Delta S/R$ .

Figure 3 A exhibits this relation for various types of alloys and Figure 3 B displays the intriguing fact that the  $\text{TiMn}$  multielements series ranges fairly widely in temperature. Some examples of actual formation heat, meanwhile, are  $-7.2$  Kcal.per mol for  $\text{LaNi}_5\text{H}_{6.7}$ ,  $-6.7$  Kcal.per mol for  $\text{TiFeH}_{1.95}$ ,  $-17.8$  Kcal.per mol for  $\text{MgH}_2$ , and  $-15.4$  Kcal.per mol for  $\text{Mg}_2\text{NiH}_4$ . The  $\text{Mg}$  series evidently has larger values.

One question other than that of the plateau pressure above is the difference between the equilibrium pressures of hydrogen absorption and release, i.e., the question of hysteresis. Figure 4 shows the PCT characteristics of the absorption and liberation of hydrogen for a few alloys. The question of how such hysteresis is produced has yet to be explained. It seems, nevertheless, that an interlattice stress due to an expansion of the lattices which run parallel with the hydridation of the alloy is involved. It has been observed for the  $\text{MmNiAl}$  alloy series that the hysteresis factor  $H_f$ , which is the ratio of the absorption plateau pressure  $P_a$  to the dissociation plateau pressure  $P_d$  and is denoted by  $\ln P_a/P_d$ , is linearly related to a crystal lattice constant, the ratio of the  $c$  axis to the  $a$  axis  $c/a$ . The greater is the ratio  $a/c$ , the

smaller will be its hysteresis. The hysteresis effect is large for zirconium and smallest for copper. Some of the actual values of Hf are: around 0.44 for  $\text{MnNi}_{4.7}\text{Al}_{0.3}$ , 0.23 for  $\text{MnNi}_{4.7}\text{Al}_{0.3}\text{Co}_{0.1}$ , and 0.09 for  $\text{MnNi}_{4.7}\text{Al}_{0.3}\text{Zr}_{0.1}$ . The effect of additional metals in reducing hysteresis is also observed in the TiMn series. Figure 4 gives, as an example, the case of the alloy  $\text{Ti}_{0.52}\text{Zr}_{0.48}\text{Mn}_{0.8}\text{Cr}_{1.0}\text{Cu}_{0.2}$  with an Hf of around 0.1 at any temperature.

#### 4. Finely Divided Powders

Still another question in terms of practical application of hydrogen storage alloys is the pulverization of the alloy going on with repeated absorption and release of hydrogen. Differences in the degree of pulverization have been noted among alloys, particularly during the early cycles of the absorption and release of hydrogen.  $\text{TiMn}_{1.5}$  exhibits pulverization earliest with its particles reduced to several microns in size after only several cycles of the reaction and diminished by one order of magnitude further after 1,000 cycles of the reaction have been repeated. It is also known that  $\text{LaNi}_5$  is reduced in size to below 400 meshes after 10 cycles and that  $\text{MnNi}_{4.5}\text{Al}_{0.5}$  and  $\text{MnNi}_{0.5}\text{Mn}_{0.5}$  are more subject to pulverization than is  $\text{MnNi}_{2.5}\text{Co}_{2.5}$ . Conversely, the alloy TiFe undergoes pulverization only to a limited extent and keeps largely a powder size of 100 to 200 meshes even after more than 5,000 cycles.

This pulverization seems to be attributable to the expansion of alloys which takes place in parallel with hydrogen absorption. After hydrogen absorption, the alloy TiFe expands by 14 percent and the alloy  $\text{LaNi}_5$  by 25 percent. After having been pulverized, the alloy may produce local stress to the container by expansion during hydrogen absorption, reduce the efficiency of heat conductance, and block pipes and valves, leading to faulty operation.

Even if such pulverization is essentially an inevitable consequence, efforts have been made with a view to blocking this by improving the alloy, using additives and filters, etc. Some examples, as seen in the MnNiAl series and the MnNiMn series of alloys, are replacement of Al and Mn partly by zirconium or simple addition of zirconium and mixing of the alloy with silicon oil. Attachment of alloy particles to a porous metal skeleton is also being performed to cope with a drop in heat conductance. The use of copper microcapsules in the MnNi series of alloys has the same aim.<sup>7</sup>

#### 5. Lifespan of the Alloys

The extent of deterioration of a hydrogen storage alloy may be evaluated by repeating cycles of absorption and liberation of hydrogen, and subsequently measuring the capacity of the alloy. This life of hydrogen storage alloys is dictated by the quantity of the alloy, its packing conditions, types of hydrogen sources as associated with impurity, temperature, pressure, etc. a good choice of alloys on the basis of their applications is mandatory.

For example, an experiment was carried out with an apparatus as illustrated in Figure 5. Using commercial, pressurized hydrogen in cylinders of the JIS 4th grade as a source of hydrogen, absorption was effected under pressure of up to 40 atms and at normal temperatures and liberation was under pressures going

down to  $10^{-2}$  mm Hg also at normal temperatures. Each cycle of the reaction lasted 30 minutes. Results of the experiment, as presented in Figure 6, proved that  $\text{LaNi}_5$  displays a sudden, sharp fall in capacity and that, though the capacity of the alloy is retrieved by keeping it under a pressure of around  $10^{-2}$  mm Hg at 500 degrees C for an hour, it undergoes the same deterioration as cycles are repeated. It was also proved, however, that in the TiMn multi-elements series, deterioration is limited to 20-30 percent even after repetition of 10,000 cycles.<sup>6</sup>

In addition, life tests involving 500 cycles of repetition, with each cycle lasting 30 minutes, were carried out for the TiFe and MnNi series. The results proved that  $\text{MnNi}_{4.5}\text{Al}_{0.5}$ , for example, absorbs 160 milliliters of hydrogen per gram initially, but around 140 milliliters after 500 cycles of the reaction--a comparatively large drop in capacity, and that  $\text{MnNi}_{4.5}\text{Cr}_{0.5}$  suffers a greater degree of deterioration in function, down to 87 percent. It also showed that TiFe has its second plateau (in Figure 2 B) gone after 100 cycles of the reaction but keeps its first scarcely diminished after 500 cycles.<sup>4</sup>

These drops in the capacity of hydrogen storage are attributable to the pollution of the alloy by contaminant gases such as oxygen, carbon dioxide, carbon monoxide, sulfur dioxide, and chlorine, as well as to the phase separation and phase change of the alloy. The alloy TiFe seems more susceptible to this contamination effect than the  $\text{TiFe}_{1-x}\text{Mn}_x$  series and the alloy  $\text{LaNi}_5$ . In fact, it has been reported that in a reaction-cycle test, at a temperature of 85 degrees C,  $\text{CaNi}_5$  suffers deterioration after 200 cycles of the reaction, but that  $\text{LaNi}_5$  remains intact after 5,000 cycles.<sup>9</sup> The results in Figure 6, meanwhile, were affected substantially by the presence of contaminant gases. The presence of 10 ppm of oxygen produces an adverse effect, as does 100 ppm of chlorine. In a survey on the effect of 300 ppm of water vapor, oxygen, and carbon monoxide, on the other hand, carbon monoxide exerted the most adverse effect on alloys, with the alloy TiFe forced by this gas to part with absorption capacity after only four cycles of the reaction.

## 6. Miscellaneous

In addition, requirements for hydrogen storage alloys are: easy activation in the initial phase, high safety, low price, etc. The TiFe series of alloy, in particular, is characterized by difficulties in the initial phase, which are being tackled by the addition of oxide, Mn, etc.

### Development of Applications in the Coming Years

Current cylinders for hydrogen storage require pressure as high as 150 to 200 kg per  $\text{cm}^2$ , with a liquid hydrogen temperature as low as -253 degrees C. Methods of storage and transportation of the substance with high safety and high efficiency are being explored.

For example, a hollow cylinder made of an alloy of the TiMn series with a capacity for hydrogen storage of around 180 milliliters per gram was produced. It achieved a reduction in volume of some 80 percent and in weight of some 30 percent compared with ordinary hydrogen cylinders. A vessel made up of 28

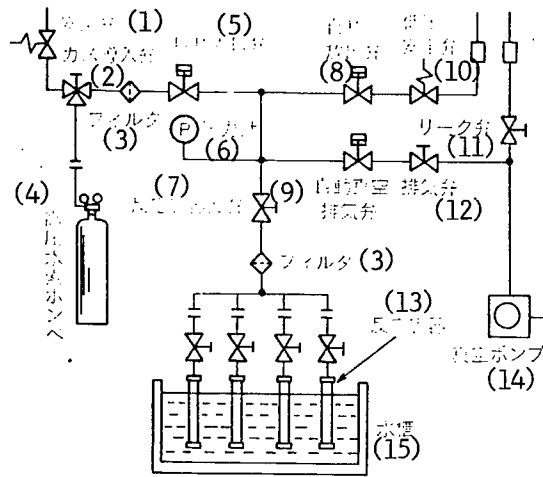

Figure 5. Diagram of an Automated Apparatus for Measuring the Life Span of an Alloy With Respect to Cycles of Hydrogen Absorption and Release

Key:

1. Safety valve
2. Gas inlet valve
3. Filter
4. Hydrogen cylinder containing the gas at high pressure
5. Automatic inlet valve
6. Pressure gauge
7. Main valve of the reactor
8. Automatic release valve
9. Automatic vacuum outlet valve
10. Low pressure safety valve
11. Leak valve
12. Outlet valve
13. Reactor
14. Vacuum pump
15. Water tub

aluminum tubes with attached internal fins, as shown in Photo 2 [omitted], meanwhile, was packed with 7.7 kg of  $TiMn_{1.5}$  and tested. Results for hydrogen dissociation characteristics are shown in two charts attached to Photo 2. Total hydrogen stored in the vessel was  $2.9 Nm^3$ .<sup>3</sup>

Capacity for heat exchange is a major factor in effecting rapid absorption and release of hydrogen. Vessels made up of a number of tubes are favored in this respect, also by virtue of blockage of aggregate formation from the pulverized alloy. With a view to speeding up heat exchange, an apparatus of the installation type was produced such that water of 5 degrees C and 75 degrees C is provided at the time of hydrogen storage and liberation, respectively. The alloy  $MnNi_{4.5}Mn_{0.5}$  of total hydrogen capacity  $16 m^3$  was used. Also developed was an apparatus of the medium size with supplies of water of 30 degrees C and 50 degrees C during hydrogen absorption and liberation, respectively, and which uses the alloy  $TiFe_{0.9}Mn_{0.1}$  and has a hydrogen capacity of  $260 m^2$ .<sup>1</sup>

As described above, the alloys have a sure prospect of commercial application in terms of hydrogen storage. Nevertheless, they have only poor prospects in the transportation of substances because not much is expected from the alloys for the reduction of weight. Though alloys of the Mg series with high capacity for hydrogen absorption may be favored in improving the weight-efficiency factor, a heat source to be used for the liberation of hydrogen is not available to them except in cases where waste heat and so forth are accessible. An alloy with a high capacity for hydrogen absorption at normal temperatures is a key to the problem.

## 2. Fuel Source for Automobiles

To curtail petroleum spending and reduce contamination involved, developmental efforts are underway for the use of hydrogen stored in the hydrogen storage alloys as an automobile fuel. The energy density was estimated on the order of 500 to 1,000 watt-hours per kilogram of the alloy, which is far below that of gasoline of 13,000 watt-hours. Some people regard liquid hydrogen as more promising. Others still favor the use of the alloy since the secondary battery of electric automobiles, which are to serve the same objective as the alloy automobiles, has values of only 40 to 150 watt-hours.

Alloys of the  $TiCrMn$  series,  $MnNi$  series, etc. are being investigated for this purpose. Liberation of hydrogen is induced by the use of warm water. Some use a carburetor that mixes hydrogen and air in the combustion chamber in order to prevent a backfire resulting from the advance of fuel into the air inlet tube and its combustion there because hydrogen is more inflammable than gasoline.

If 70 kilograms of the alloy  $MnNiMn_{0.5}$  is mounted on an automobile and 11.3 cubic meters of hydrogen packed, and if 1 cubic meter of hydrogen permits, as reported, an automobile to run for a distance of 5 to 6 kilometers, one packing operation for hydrogen may permit a car to run a distance of 55 to 65 kilometers. A car mounted with the alloy in a quantity three times the above figure can cover almost any practical range required of it. Other researchers investigated a vehicle with the alloy  $FeTiMn$  mounted primarily with a view to lowering its operating temperature and pressure and curtailing its weight.<sup>11</sup>

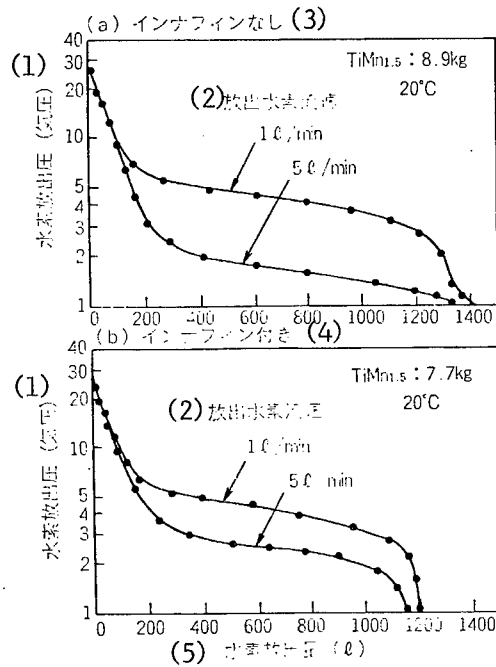

Photo 2. [Attached Charts] Relationship of the Quantity of Hydrogen Released to the Pressure of the Released Hydrogen for a Hydrogen-Storage Container of Multiple-Pipe Type Using the Alloy Series TiMn /\_photo omitted\_/

Key:

1. Pressure for hydrogen release, in atms
2. Speed of the flow of hydrogen
3. Container not equipped with internal fines
4. Container equipped with internal fines
5. Quantity of hydrogen released

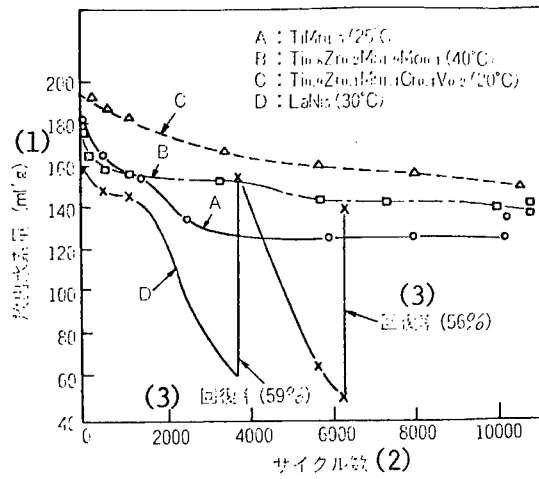

Figure 6. Life Span With Respect to Cycles of Hydrogen Absorption and Release for Alloys of the TiMn Series and the Alloy LaNi<sub>5</sub>

Key:

1. Quantity of hydrogen releasable
2. Number of cycles of the reaction
3. Rate of recovery

Still others, in order to step up the distance that can be covered by vehicles, coupled the alloy TiFe, which can release hydrogen at low temperatures but has a low capacity for hydrogen storage, with the metal Mg or Mg<sub>2</sub>Ni, which has a high capacity for hydrogen storage but needs waste heat of the engine for the release of its hydrogen.<sup>12</sup> This device may indicate one direction of future development (see Figure 7).<sup>13</sup>

### 3. Apparatuses for Hydrogen Refining

Hydrogen is presently manufactured largely by means of catalytic steam reforming of hydrocarbons, partial oxidation of the heavy fractions of petroleum, catalytic reforming of coke-oven gas and petroleum, etc. The chemical industry and the semiconductor industry, which require hydrogen of particularly high purity, have to resort to such means as the subzero temperature absorption method and separation using a palladium alloy membrane in order to eliminate contaminants from the gas. The latter method, though available for the purification of all impure gases and affording a high degree of purity to the gas, involves difficulties in connection with the durability of the membrane, price, the need for high temperatures, etc. Thus, the choice of hydrogen storage alloys instead.

An apparatus for the purification of hydrogen with a circuit system as given in Figure 8 was trial manufactured.<sup>3</sup> Two vessels containing a hydrogen-storage alloy were coupled such that the release of hydrogen may be made continuously and that the heat so generated may be available for both. The alloy TiMn<sub>1.5</sub> was packed into the vessels, and hydrogen from the commercial hydrogen cylinder was used as the source.

Following the experiment, it was found on the basis of gas chromatographic analysis that no traces of the gases O<sub>2</sub>, N<sub>2</sub>, CH<sub>4</sub>, CO, and CO<sub>2</sub> were detectable in the hydrogen gas produced in the plateau region of the reaction pressure, whereas they had previously been proved in the amounts of 0.3 ppm, 11.1 ppm, 0.17 ppm, 0.02 ppm, and 0.42 ppm, respectively, in the source hydrogen. The purity of the hydrogen was increased from 99.9 percent to over 99.9999 percent. The speed of removing contaminant gases by the alloy, was compared with those for the alloys LaNi<sub>5</sub> and TiFeMn<sub>0.1</sub> at the same time. The alloy TiMn<sub>1.5</sub> disposed of the gases N<sub>2</sub>, O<sub>2</sub>, and CH<sub>4</sub> such that the hydrogen produced attained a high purity in terms of these contaminants, except the initial 3 percent of the yield, whereas several percent of the yield had to be discarded for the other alloys. The speed of removing contaminants after repeated cycles of hydrogen absorption and release was also investigated. This was done in form of accelerated tests. An alloy TiMn<sub>1.5</sub> after repetition of 6,000 cycles exhibited a speed approximately equivalent to that of alloy LaNi<sub>5</sub> following a repetition of 10 cycles.

The effect of the purification of hydrogen gas by means of the alloy MnNi<sub>4.5</sub>Al<sub>0.5</sub> was also examined. Oxygen is absorbed partly on the surface of the alloy, and reacts with the hydrogen partly to yield water. Nitrogen is absorbed on the alloy surface only in a very limited amount and largely increases its concentration as a gas in space. Carbon monoxide and carbon dioxide are also absorbed on the alloy surface. The capacity of the alloy for hydrogen storage, thereby, is reduced but retrieved by the supply of pure

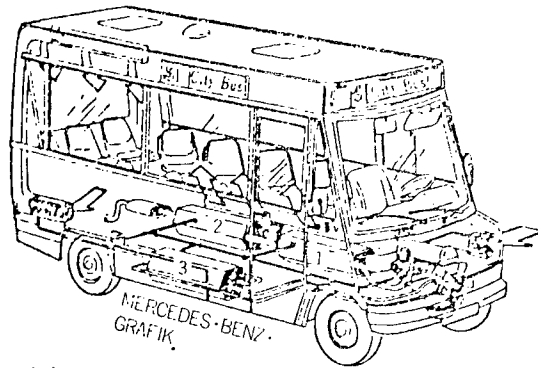

- (1) 1. 高溫 MH, 排氣加熱  
 (2) 2. 低溫 MH, 排氣加熱, H<sub>2</sub>O 凝結, 冷卻, 冷空氣  
 應進入室給用水口加濕  
 (3) 3. 低溫 MH, 液體加熱, 冷卻室

Figure 7. Bus With a Hydrogen Storage Alloy Mounted

Key:

1. High temperature metal hydride heated by exhaust fumes.
2. Low temperature metal hydride heated by exhaust fumes, H<sub>2</sub>O condensation, the arrows indicate the flow of ventilating air, used for the water to be supplied to the inlet air.
3. Low temperature metal hydride heated by liquid, which is used for cooling the room.

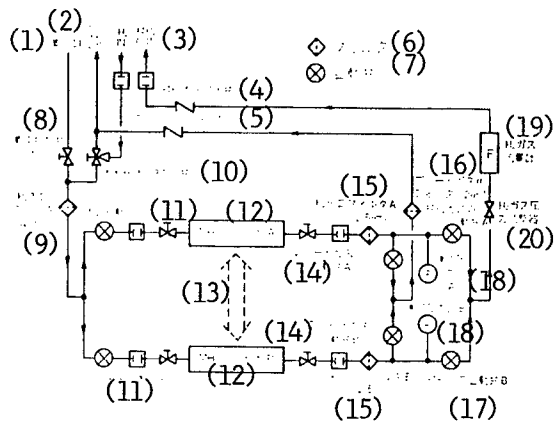

Figure 8. System of Apparatuses for the Manufacture of Hydrogen of High Purity Using the Hydrid  $TiMn_{1.5}$

Key:

1. Vacuum inlet
2. Breed-hydrogen outlet
3. Pure hydrogen outlet
4. Check valve for pure hydrogen
5. Check valve for breed hydrogen
6. Filter
7. Automatic valve
8. Gas outlet valve for vacuum
9. Hydrogen-inlet filter
10. Three-way valve for raw-material hydrogen
11. Inlet automatic valve
12. Metal-hydrid container
13. Heat exchange
14. Automatic valve for breed gas
15. Hydrogen outlet filter
16. Filter for breed gas
17. Automatic valve for pure hydrogen
18. Coupled pressure gauge
19. Flow meter for hydrogen
20. Regulator of hydrogen pressure

hydrogen or degasification treatment. It has been noted that the alloy acts as a catalyst for the formation of methane and water from hydrogen and carbon monoxide. The formation of methane, nevertheless, is not favored in some types of applications. The MgNi series, still another alloy having been studied in this connection, exhibited superior characteristics in hydrogen purification rather than in transport of the material.<sup>14</sup>

#### 4. Heat Pump

Two types of hydrogen-storage alloys whose equilibrium hydrogen-pressures are different are coupled such that heat emitted or absorbed is utilized as hydrogen is absorbed or released by a difference in pressure. A heat-energy conversion cycle system which is made up of two or more types of the alloy permits the flow of heat from high to low temperatures or vice versa, and thus acts as a heat pump. This is a quiet thermal machine which permits effective application of waste heat and which is capable of operation in a wide range of temperatures compared with conventional heat pumps based on compression by means of an electromotor or on absorption.

The heat of formation derived from the reaction of the alloy with hydrogen must be as large as possible since differences in temperature have to be used. It is also essential for the high efficiency of this system that hysteresis of the alloy be small, the plateau of the reaction pressure large, and the reaction fast. Alloys of the rare earth group are favored over the others for this purpose. Alloys with small hysteresis and a long plateau curve are presented in Table 2. The TiMn series of alloys have their hysteresis values improved by rendering constituent elements multiple. The alloy  $\text{Ti}_{0.8}\text{Zr}_{0.2}\text{Mn}_{0.8}\text{Cr}_{1.2}$  for high pressure applications and the alloy  $\text{Ti}_{0.35}\text{Zr}_{0.65}\text{Mn}_{1.2}\text{Cr}_{0.6}\text{Co}_{0.2}$  for low pressure applications have values of around 0.45 and 0.29, respectively. Though these values still cannot meet the provisional target value of 0.25, the two alloys used in combination with the aid of a 150 degrees C heat source are capable of bringing down the temperature of the surface of pipes to -9.7 degrees C in one minute and to -25.2 degrees C in 20 minutes. Meanwhile, as shown in Figure 4, the five-element alloy  $\text{Ti}_{0.52}\text{Zr}_{1.46}\text{Mn}_{0.8}\text{Cr}_{1.0}\text{Cu}_{0.5}$  has a hysteresis factor below 0.10 at temperatures 75-100 degrees C, suggesting the possibility of improved efficiency of the system on the basis of an improved alloy.

#### 5. Battery

The application of this type of alloy in batteries is either direct or indirect. The direct method involves use of the alloy as an electrode itself. In the indirect method, either hydrogen produced by using surplus electric power or natural energy is stored by means of the alloy and later supplied to the fuel electrode of a fuel cell. Also, hydrogen generated at the cathode of a secondary battery is stored by the alloy and later returned when the battery discharges. This latter application belongs also to the domain of storage and purification.  $\text{LaNi}_5$  finds uses in secondary batteries, with long life under low pressure accomplished. Where D-size 5 Ah batteries are concerned, water vapor seems to have adverse effects on the alloy. It is also conceivable that fuel cells may provide both heat and electric power.

Table 2. Alloys for Use in Heat Pumps and Their Power Levels

Alloy	Cycle and Power (Kcal/hr)
LaNi <sub>5</sub> , CaNi <sub>5</sub>	Heat-amplifying cycle
MmN <sub>4.15</sub> Fe <sub>0.85</sub> , LaNi <sub>4.7</sub> Al <sub>10.3</sub>	Heat-amplifying cycle
LaNi <sub>5</sub> , LaNi <sub>4.7</sub> Al <sub>0.3</sub>	Temperature-raising cycle 3.5 (kW)
LaNi <sub>4.5</sub> , Al <sub>0.5</sub> LaNi <sub>5</sub>	Freezing cycle 3000
LaNi <sub>4.7</sub> Al <sub>0.3</sub> , TiFe <sub>0.8</sub> Ni <sub>0.2</sub>	Heat-amplifying cycle 50 (kW)
MmN <sub>4.15</sub> Fe <sub>0.85</sub> , MmNi <sub>4.5</sub> Al <sub>0.5</sub>	Temperature-raising cycle
Ti <sub>0.9</sub> Zr <sub>0.1</sub> CrMn, LaNi <sub>5</sub>	Freezing cycle
LaNi group, LaNiAl group	Heat-amplifying and cooling cycles 9,660
LaNi <sub>5</sub> group, MmNi <sub>5</sub> group	Cold-heat generating cycle
MmNi <sub>5</sub> group, 2 kinds	Cold-water generating cycle
LaNi <sub>5</sub> , LaNi <sub>4.7</sub> Al <sub>0.3</sub>	Temperature-raising cycle 3000

In the direct method, the alloy is used as a reversible hydrogen electrode, in which hydrogen generated during charging is stored and which uses the hydrogen during discharging. Developmental efforts for the application of alloys in the seal type of battery is also underway. The alloys to be used need to fulfill various requirements which are associated with stability, dependence on temperature, electrode-reaction over voltage, amenability to molding, costs, and many other factors.

Theoretical energy density of cells using the nickel electrode as the anode are 161 watt-hours per kilogram for the lead acid battery, 209 watt-hours for the NiCd battery, and a rather high value of 275 watt-hours for  $\text{LaNi}_5\text{H}_6$ .

Alloys used for this purpose are largely rare earth element series and TiNi series and partly TiMn series. Some alloys of MmNi series are coated with copper in the form of microcapsules and have capacities and life spans thereby improved.<sup>16</sup> Results of packing alloys in foamed nickel of high porosity proved that  $\text{La}_{0.2}\text{Ca}_{0.8}\text{Ni}_5$  is excellent and that, by heat treatment,  $\text{LaNi}_{4.25}\text{Mn}_{0.75}$  and  $\text{MmNi}_{4.25}\text{Mn}_{0.75}$  have their consistency rendered uniform, their hysteresis factor reduced to 0.196, and their capacity raised beyond 0.3 Ah per gram.<sup>7</sup>  $\text{LaNi}_{0.7}\text{Al}_{0.3}$ , as examined in a sealed cell, meanwhile, proved able to maintain a high capacity of over 0.24 Ah per gram and, as for its life span, to have its capacity for hydrogen absorption reduced by a limited 5 percent or so after 200 cycles.<sup>8</sup> In addition, it has been suggested that the cell may be designed in such a way that it can be used in direct or indirect manner, i.e., it may be charged by supply of hydrogen or electrically as illustrated in Figure 9.<sup>9</sup> Also under study is a cell of the solid electrolyte system, e.g.  $(-)\text{Na}/\text{Na}^+\text{H}^-$  in  $\text{NaAlEt}_4/\text{hydride}(+)$ , as a problem of electrochemical research.<sup>20</sup>

## 6. Miscellaneous

One application other than those described above is that of catalysts. Hydrogenation of carbon monoxide, dealkylation of aromatic compounds, and hydrogenation of ethylene are conceivable. It has also been noted that the alloy, when coupled with platinum catalysts, enhances dehydrogenation of cyclohexane.<sup>21</sup>

Also in development are quiet compressors, which make use of the pressure produced upon release of hydrogen from the alloy; chemical engines, which use the function of the alloy converting thermal energy into pressure; heat-accumulating agents; temperature sensors, etc. Efforts are being made to separate deuterium and tritium, the raw materials to be used in future nuclear fusion, from hydrogen on the grounds that hydrogen is released first at low pressure from the alloy when a mixture of the three gases is used.

A large number of applications of hydrogen-storage alloys have been suggested in connection with their absorption and release of hydrogen. The heat and pressure thereby created, among other things, and a reactor for purification of hydrogen have been put on the market. It is hoped that new alloys will be made available which surpass existing ones in absorption and release of hydrogen, in speed and quantity, in life span, safety, and price.

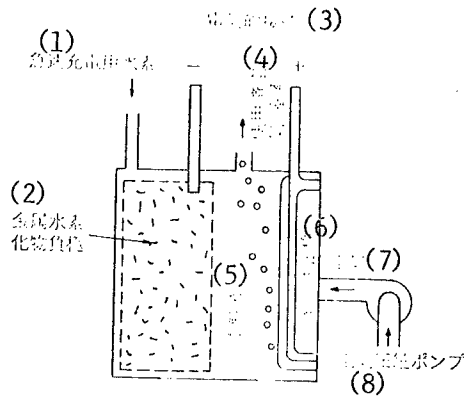

Figure 9. Hydrogen/Hybrid-Air Battery Amenable to Charging Like Usual Secondary Batteries as Well as Charging by Means of Hydrogen Gas

Key:

1. Hydrogen for rapid charging
2. Cathode of metal hydride
3. Electrical connection
4. Spent air (nitrogen)
5. Electrolyte solution
6. Porous anode
7. Air
8. Air compressor (pump)

## FOOTNOTES

1. Okado, Yasuaki, "Hydrogen Storage Alloy" Yono Publishing Corp., Jun 1985.
2. Maeland, A.J., Libowitz, G.G., Hydrides of Beryllium-Based Intermetallic Compounds J. of the Less-Common Metals, 89 (1983) p 197.
3. Gamau, Koji, Moriwaki, Yoshio, Yanagihara, Nobuyuki, Iwaki, Tsutomu, "Alloy-Hydrides of Ti-Mn Series and Their Applications," N.T.R., 29 (1983) p 78.
4. Kuroda, Seihiro, "Hydrogen-Storage Alloys," Application Technology Publishing Corp., Nov 1984.
5. Schlapbach, L., Seiler, A., Stucki, F., and Siegmann, H.C., Surface Effects and the Formation of Metal Hydrides, J of the Less-Common Metals 73 (1989) p 145.
6. Amano, Muneyuki, Sasaki, Yasuo, Yoshioka, Takayuki, "Effects of Oxide Phase and  $\beta$ -Ti Phase on the Hydridation Characteristics of FeTi Phase," Journal of the Japan Metallurgy Society, 45 (1981) p 957.
7. Ishikawa, Hiroshi, Oguro, Keisuke, Kato, Akihiko, Suzuki, Hiroshi, Ishii, Eiichi, "Characteristics of Hydrides in Microcapsules," the 50th Annual Spring Meeting of the Japan Chemical Society.
8. Gamo, T., Moriwaki, Y., Yanagihara, N., and Iwaki, T., Life Properties of TiMn Alloy Hydrides and Their Hydrogen Purification Effect, J. of the Less-Common Metals 89 (1983) p 495.
9. Goodell, P.D., Stability of Rechargeable Hydriding Alloys During Extended Cycling, J. of the Less-Common Metals 99 (1984) p 1.
10. "Hydrogen Storage Alloys Soon to Bear Fruit," NIKKEI MECHANICAL (1982.9) p 114.
11. Bradhurst, D.H., Heuer, P.M., The Properties of a Metal Hydride Fuel for Use in an Urban Vehicle, J. of the Less-Common Metals 89 (1983) p 575.
12. Buchner, H., The Hydrogen/Hydride Energy Concept Int. J. Hydrogen Energy 3 (1978) p 385.
13. Furuhashi, Shoichi, "The Present and Future States of Hydrogen Engines," Automobile Technology, 34 (1980) p 311.
14. Ono, S., Ishido, Y., Akiba, E., Jindo, K., Sawada, Y., Kitagawa, I., and Kakutani, T., MgNi Alloys as Hydrogen Transporting Media, Hydrogen Energy Prog. 3 (1984) p 1291.
15. Iwakura, Chiaki, "Batteries Using Hydrogen Storage Alloys," CMC, Ltd., (1985.3) p 178.

16. Iwakura, Chiaki, Asaoka, Sakahiko, Sakai, Tetsuo, Ishikawa, Hiroshi, Oguro, Keisuke, "Use of  $\text{LaNi}_5$  of Microcapsule Form as the Cathode of the Nickel-Hydrogen Secondary Battery," A Collection of Abstracts of Lectures at the 52nd General Meeting of the Electro-Chemical Association, (1955) p 82.
17. Ikoma, Munehisa, Kawano, Hiroshi, Moriwaki, Yoshio, Yanagihara, Nobuyuki, "Applications of Hydrogen Storage Alloys in Batteries (II)," A Collection of Abstracts of Lectures at the 52nd General Meeting of the Electrochemical Association, 1985.
18. Kanda, Hajimu, Sato, Yuji, "Electrode Characteristics of Hydrogen-Storage Alloys," A Collection of Abstracts of Lectures at the 25th Meeting for the Discussion on Batteries," (1984) p 356.
19. Videm, K., Hydrides for Energy Storage, Pergamon Press (1978) p 463.
20. Luedecke, C.M., Deublein, G., and Huggins, R.A., Electrochemical Investigation of Hydrogen Storage in Metal Hydrides J. Electrochem. Soc. 132 (1985) p 52.
21. Imai, Hisao, Tagawa, Tomohiko, Ishikura, Michio, "Enhancing Action of Hydrogen-Storage Alloys on the Catalytic Dehydrogenation of Cyclohexane," CATALYST, 27 (1985) p 143. [All footnote numbers in text are as published.]

#### Amorphous Alloys

Tokyo KOGYO ZAIRYO in Japanese Oct 85 pp 48-52

[Article by Yasuo Yamamoto, chief researcher of the Enterprise-Developing Office of Osaka Transformer Co., Ltd.]

[Text] Application of amorphous magnetic materials in transformers for electric power transmission has long been an intriguing subject for manufacturers of transformers. They have been pressing ahead with developmental work through trial manufacture and testing to solve the problems involved. Since its trial manufacture and publication of a 6 kV, 10 kVA transformer using an amorphous iron core, the first practical one for electric power supply, in July 1981, Osaka Transformer Co., Ltd. has been actively gaining basic data on the basis of both model and practical iron cores.

This paper deals with a comparison of the character and problems involved in amorphous magnetic material with those for silicon steel plate. It presents a brief introduction of the concept for the design and manufacture of the material, recent trends, and future prospects, with a view to apply it in transformers and particularly in relays in power transmission lines.

#### Amorphous Magnetic Material

Amorphous alloys have been in the limelight since Prof Duwez of the United States produced such material by the Gunn method in 1960. Prof Matsumoto of

Japan then prepared a continuous ribbon of foil of the material by the liquid rapid cooling method in 1970. Study of physical properties has gathered momentum, since leading to the discovery of a number of alloys for soft magnetic materials.

The study of amorphous alloys for soft magnetic materials was embarked on first with the Fe-P-C series, and subsequently the Fe-B series was spotlighted for use in power transmission. Much research is presently being carried out on Fe-B-Si series and Fe-B-Si-C series because of their practical composition.

Among the properties of a material favored as the core of a transformer are, in terms of electromagnetics: 1) low loss, 2) high saturated magnetic flux density, 3) high magnetic permeability, 4) low magnetostriction, 5) high Curic point and minimum variation of magnetic properties with temperature, 6) high electrical resistance, and, in terms of manufacturing, 7) high liability to the amorphous state or facile transition to the amorphous form. Also, 8) good processability, 9) minimum deterioration of properties due to processing, and 10) high space factor are also important.

Among the iron series of amorphous materials which have so far been examined and studied are: 1) Fe-B-C series, e.g.,  $\text{Fe}_{86}\text{B}_7\text{C}_7$  of saturation flux density 1.78 T, 2) Fe-B series, e.g.,  $\text{Fe}_{80}\text{B}_{20}$  of saturation flux density 1.6 T, 3) Fe-B-Si series, e.g.,  $\text{Fe}_{78}\text{B}_{13}\text{Si}_9$  of density 1.56 T, 4) Fe-B-Si-C series, e.g.,  $\text{Fe}_{81}\text{B}_{13.5}\text{Si}_{3.5}\text{C}_2$  of density 1.61 T. Of these, the Fe-B and Fe-B-C series were omitted because of their poor heat stability, with a crystallization temperature of around 300 degrees C. On the other hand, the Fe-B-Si and Fe-B-Si-C series have extensive applications due to their high crystallization temperatures and good magnetic properties. In comparing the latter two series, the Fe-B-Si series of amorphous materials has better magnetic properties, though its saturated magnetic flux density is somewhat lower than the other, as evidenced by MEIGLAS 2605 S-2, a product of Allied Corp. Fe-B-Si series, on which is presently based the development of transformer cores. In addition to the application of amorphous alloys in power transmission, many are in development on the basis of their superior properties and, in the sector of radio frequency-wave application, sales of alloy materials of cobalt series and nickel series are being pushed ahead rapidly in place of iron series, as are commercialization of application products of these materials.

Amorphous materials currently commercially available are presented in Table 1 based on a catalog of Allied Corp.

#### Economic Effects of Transformers Using Amorphous Iron Cores

Amorphous magnetic materials have been in the spotlight in the transformer industry because of their energy conservation effect in connection with curtailing non-load loss. The effect of their application may be estimated as follows: Transformers, as major equipment for electric power transmission, are used in large numbers along power lines from power stations to plants, houses, and other users. Electricity generated at power stations, meanwhile, suffers various losses before it reaches the user. These losses amount to 6 percent, in the case of Japan, of the total of 620 billion kilowatt-hours generated in fiscal 1983. Of these losses, more than half are produced in the power supply sector, and nearly 40 percent of the loss of this sector is due to relay transformers.

There are two factors in power loss resulting from transformers: non-load loss, which results from mere connection of a transformer to the power supply line, and load loss, which increases in amounts in proportion to the power consumed by the user. The former, however, is twice as large as the latter and, efforts have been made to reduce load-loss of transformers by improving both materials and processing methods. It is expected that this non-load loss can be cut to less than one-third by the application of amorphous materials.

With over 8 million relay transformers across the nation in the power distribution section alone, a complete switching from conventional to amorphous materials will permit, on the basis of an average of 25 RVA, a conservation of power of an annual 3 billion kilowatt-hours in that section alone, double that quantity if the figure in the power transmission section is added.

#### Comparison of Amorphous Materials with Silicon Steel

Various materials have been investigated in connection with their application in electric power transformers. Developmental efforts have been and are being made on the basis of METGLAS 2605 SC initially and METGLAS 2605 S-2 presently, both of Allied Corp.

Amorphous materials are compared with silicon steel in Table 2. Notable features of the former, as compared with the latter, are: isotropic soft magnetic material, high electrical resistance, low power loss, low temperature for annealing, and reduced amounts of energy required for production of the material. Disadvantages, on the other hand, are: reduced thickness, low space factor, low saturation magnetic flux density, hardness and brittleness of the material, poor thermal stability, large magnetostriction and need of magnetic field annealing.

(1) METGLAS 番 号	(2) 组 成	(3) 飽和磁束密度 密度Bs: T	(4) 与最大磁束率 Hc A m	(5) 最大磁束率 $\mu_{max}$	(6) キュリー温度 温度Tc(°C)
2605 SC	Fe <sub>81</sub> B <sub>13.5</sub> Si <sub>3.5</sub> C <sub>2</sub>	1.61	3.3	300,000	370
2605 S-2	Fe <sub>78</sub> B <sub>13</sub> Si <sub>9</sub>	1.56	2.4	300,000	415
2605S-3A		1.41	4.8		388
2605 CO	Fe <sub>77</sub> Co <sub>18</sub> B <sub>14</sub> Si <sub>1</sub>	1.80	4.0	250,000	415
2826 MB	Fe <sub>80</sub> Ni <sub>10</sub> Mo <sub>1</sub> B <sub>9</sub>	0.88	1.2	600,000	353

Table 1. Properties of Amorphous Magnetic Materials of Allied Corp.

Key:

1. Number
2. Composition
3. Saturation flux density
4. Coercive force
5. Maximal magnetic permeability
6. Curie temperature

	(1) 項	II	METGLAS 2605S-2	現用けい素鋼 (2) Z-6H0.23t
(3)	電 磁 氣 的 性 質	鉄損 (W/kg) 1.4T 60Hz (4)	0.2	0.75
		励磁特性 (VA/kg) " (5)	0.25	
		飽和磁束密度 (T) (6)	1.56	2.03
		抗磁力 (Oe) (7)	0.03	
		磁歪 (8)	(23) 大きい	小さい (24)
		固有抵抗 ( $\mu\pi$ cm) (9)	130	45
(10)	物 理 的 機 械 的 性 質	厚み ( $\mu$ m) (11)	28	300
		比重 (12)	7.18	7.65
		占積率 (%) (13)	>75	97
		結晶化温度 (°C) (14)	550	—
		キュリー一点 (°C) (15)	415	746
		抗張力 ( $\text{kg/mm}^2$ ) (16)	>150	32
		硬 度 Hv (17)	900	210
(18)	焼 鈍 条 件	温 度 (19) (°C)	400	780-820
		時 間 (20) (h)	2	2
		磁場条件 (Oe) (21)	10	—
		雰囲気ガス (22)	N <sub>2</sub>	N <sub>2</sub>

Table 2. Comparison of METGLAS 2605 S-2 With Conventional Silicon Steel

Key:

1. Item
2. Conventional silicon steel
3. Electromagnetic properties
4. Iron loss
5. Excitation characteristics
6. Saturation flux density
7. Resistance to magnetic force or antimagnetic force
8. Magnetostriction
9. Specific resistance or resistivity
10. Physiomechanical properties
11. Thickness
12. Specific gravity
13. Space factor
14. Crystallization temperature
15. Curie temperature
16. Tensile strength
17. Hardness
18. Annealing conditions
19. Temperature
20. Time
21. Magnetic-field conditions
22. Atmospheric gas
23. Large
24. Small

## Application of Amorphous Materials in Transformers

Application of the material in transformers involves largely three areas: questions related to characteristics, questions related to processing of the material, and questions related to the life span of the material. These are accounted for briefly below by taking the design and manufacture of relay transformers as examples.

### 1. Problems Related to the Characteristics of Amorphous Materials

#### (1) Problems of Saturation Magnetic Flux Density

Both METGLAS 2605 SC and 2605 S-2 have low saturation magnetic flux density, values around 80 percent of those of silicon steels currently available, leading to designs of transformers of low magnetic flux density and large cross section areas of the iron core and, hence, large sizes of the transformer made and large quantities of the material used.

#### (2) Space Factor Problems

Because of a thickness around one-tenth that of silicon, amorphous materials, when laminated to make an iron core, have a limited actual material-to-apparent external size ratio or space factor. Silicon steel has a value of 97 percent, whereas amorphous materials have a value in the range of 75 to 80 percent. This makes the transformer larger again.

#### (3) Problem of Temperature Characteristics

The amorphous material has its saturation magnetic flux density varying slightly with temperature and dropping by some 3 percent in going from the ambient temperature to 100 degrees C. This is due to low Curie points of the material. These questions, in addition to values listed on a catalog, must be taken account of in designing transformers. Alternating-current magnetic properties, except for the above, improve with rising temperature in general.

### 2. Problems Involved in Processing of the Material

#### (1) Problem of Thickness

Standard amorphous materials have a thickness of 28 microns, a value one-tenth that of the materials currently used. They have to be laminated 10 times and, besides, the iron core produced must have a low structural rigidity, for which some means of compensation must be devised.

#### (2) Problem of Hardness

The material is not amenable to processing and handling because its hardness and tensile strength is close to five times that of currently used silicon steel and because it turns fragile when subjected to annealing.

### (3) Problem of Deterioration Due to Deformation Produced by Processing

Properties of the material deteriorate after processing such as bending, bonding, and cutting. Since the material is more sensitive to, and suffers great deterioration from deformation, a technology development on reduction of the deterioration produced in the course of processing from the material to the product is acutely needed.

### 3. Problems of Life Span

Amorphous materials, being in a semistable state, are converted to a crystal state when the temperature is raised above that of crystallization. It also must undergo structural changes, though slowly, and it approaches the crystal state even at ambient temperatures. It thereby produces gradual changes, leading to a deterioration over time of their magnetic and mechanical characteristics.

In response to this question, a number of organs have been conducting investigations such as a forced deterioration test using model iron cores, a long-term life test using actual transformers, and a field test using the transformer in an actual power supply system. No noteworthy deterioration, however, has yet to be recognized, with long-term stability being ensured.

### Designing

In designing a transformer using amorphous material as the iron core, an assessment of the iron loss involved must be a prerequisite if the low iron-loss characteristic of the material is to be used. The assessment of iron loss implies conversion of energy losses to a value or price as produced during the operation of a transformer. These values are added to those of transformers themselves for comparison.

The total price of a transformer, when the assessment of iron loss is taken into account, is as follows:

$$\text{total price of a transformer} = \text{price of transformer} + \text{price of assessed iron-loss}$$

where the price of assessed iron loss is again estimated by the formula

$$\text{price of assessed iron loss} = \text{non-load loss} \times \text{unit price of non-load loss} + \text{load loss} \times \text{unit price of load loss}$$

A trial-manufactured transformer is presented in Table 3. The value of assessed iron loss for the transformer using amorphous material as the core as compared with a transformer using silicon steel as the core is Y88,300 versus Y135,750. This value is on the assumption that the assessed unit prices of non-load and load losses are Y1,000 per watt and Y250 per watt, respectively. The prices of these transformers, added to the above respective figures, make up the total price. The assessed unit prices of iron loss provided will permit design of a transformer of a minimal total price.

The price of a transformer rises with decreasing iron loss whether or not it is non-load or load loss. The assessed price of iron loss, on the other hand, falls with a decrease in iron loss. The total price, which is the sum of the two prices, makes an upward concave curve generally. A minimal price is present for a certain value of iron loss. Figure 1 may illustrate how the total price varies with design with a 6 kV, 10 kVA transformer. When assessed unit prices of iron loss are given, transformers with certain load and non-load loss values afford the most economical function. In general, higher assessed unit prices of iron loss shift the minimal value of the total price to the lowest-iron loss side.

## Structure of Transformers

### 1. Structure of the Iron Core Made of Silicon Steel Plates

Where silicon steel plates are used as material, the iron core has two types of structures with current practical applications: 1) three-phase tape-laminated core and 2) single-phase tape-wound core. Typical of the latter structures are the following:

#### 1) Cut Core Method

The steel tapes are wound around an oblong winding frame and subjected to annealing for removal of deformation. Subsequently, they are bonded with adhesive, and cut and finished into two U-shape pieces.

#### 2) Lap Core Method

Steel tapes of length equal to the perimeter of an oblong frame are wound over the frame over one another in required thickness, such that the two edges of each tape contact firmly. This contact point of any tape advances that of the preceding one by several millimeters. The laminated tapes are then subjected to annealing for removal of deformation.

#### 3) Non-Cut Core Method

The steel tapes are stacked over one another such that the cross section of the iron core thus produced makes a circle. The core, then, is wound around an oblong frame and subjected to annealing.

Where the cut core and lap core methods are concerned, the coil is wound beforehand such that it can be coupled with the iron core by means of the gap provided to the core. In the case of the non-cut core method, on the other hand, a frame for winding coils is fixed over a worked-out iron core and an electric wire is wound around the core directly by rotating the frame. The wound tape core method for silicon steel has long been used industrially in various ways and has improved with each use. The lap core method, nevertheless, is largely used by manufacturers.

## 2. Structure of the Iron Core Made of Amorphous Material

In order to examine the iron core structure of transformers using amorphous material as the core, the method of processing the core is reviewed below.

### 1) Cut Core Method

Use of adhesives for solidification leads to deformation and, hence, to deterioration of magnetic properties. The cleavage of the product also increases deterioration by creating voids.

### 2) Lap Core Method

The product turns brittle after annealing and is not amenable to the assembling work that follows.

### 3) Laminated iron core method

The material is not adapted to lamination work because of its thinness and of its low rigidity. Nevertheless, one can see an engineering method being developed which creates a product with several sheets of the material in layers. One will have to take this product into account in the near future.

### 4) Non cut method

In order to produce a core made of multiple layers of steel tapes of varying width, such that the cross section of the core makes a circle, tapes of several widths need to be combined. Nevertheless, this method suffers minimal deterioration resulting from processing because it dispenses with other processing steps. Also in development in connection with the non-cut method is a toroid iron core, or a ring-shaped iron core around which is wound a wire as a coil. The Osaka Transformer Co., with which the author works, has selected this method for trial manufacture.

## 3. Comparison of the Structure of the Transformer Using Amorphous Materials as the Core with Conventional Transformers

Refer to Table 4 for this comparison

### Trial Manufacture

Osaka Transformer has trial manufactured several types of transformers using amorphous material as the core since it announced the development of a single-phase 10 kVA transformer of that material in 1981. This has been done in order to: 1) compare these transformers with conventional ones, 2) verify the performance of the transformers in a laboratory, a simulation of the field operation, and, 3) make field experiments. Other transformer manufacturers have so reported on the results of their trial manufactured transformers. The author would like to present, in Table 3, the case of a 1  $\theta$  , 20 kVA transformer trial manufactured and tested from joint research of seven

(1) 形	(2) 6kV油入自冷式	
(3) 相・周波数	(4) 単相 60 Hz	
(5) 容量	20kVA	
(6) 変圧器の種類	(7) アモルファス鉄心変圧器	(8) けい素鋼変圧器
(9) 鉄心材料	METGLAS 2605S-2	オリエントコア G-6H (10)
(11) 無負荷損(W)	16.8	61
(12) 無負荷電流(%)	0.12	0.39
(13) 負荷損(W)	286	299
(14) インピーダンス電圧(%)	2.2	2.2
(15) 騒音(phon)	36.3	36.0
(16) 重量(kg)	172	140

Table 3. Example of Transformer Involving an Amorphous Iron Core

Key:

1. Type
2. Oil-immersed and self-cooling types
3. Phase and frequency
4. Single phase
5. Capacity
6. Transformer iron core
7. Amorphous iron-core transformer
8. Silicon steel transformer
9. Type of iron-core material
10. Orient core G-6H
11. No load loss
12. No load current
13. Load loss
14. Impedance voltage
15. Noise
16. Weight

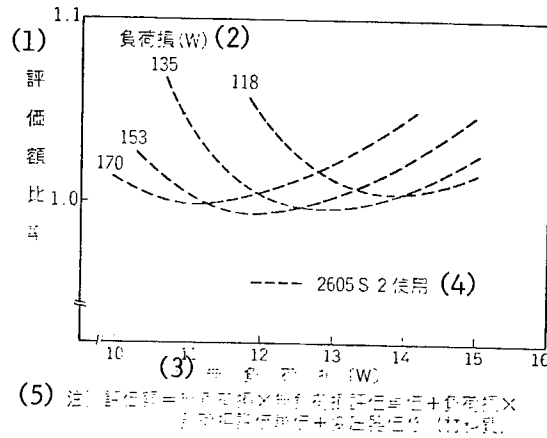

Figure 1. Theoretical Estimation of the Characteristics of a Transformer Involving an Amorphous Iron Core and Assessed Prices (10 kVA, 60 Hz)

Key:

1. Assessed price ratio
2. Load loss (W)
3. No-load loss (W)
4. 2605 S-2 used
5. Note: Assessed price = no-load loss x unit price of no-load loss + load loss x unit price of load loss + price of the transformer (material cost)



	(1)	(2)
	アモルファス鉄心変圧器	けい素鋼鉄心変圧器
(3) 鉄心と巻線の組み合せ方	鉄心を切断せず直接その上に巻付ける (4)	鉄心を切断部を作って製作し、別に巻いておいたコイルと組み合わせる (5)
(6) 鉄心断面形状	円に内接した多段鉄心 (7) 	長方形またはそれに類似の鉄心 (8) 
(9) 鉄心磁路の継ぎ目	なし (10)	1枚ごとに切れ目があり、その継ぎ目が階段状にステップしている (11) 
(12) コイル形状	円形コイル (13) 	長方形コイル (14) 

Table 4. Comparison of the Structure of the Transformer Using Amorphous Materials as the Core with Conventional Transformers

Key:

1. Transformer using amorphous material as the core
2. Transformer using silicon steel as the core
3. Method of combining a coil with an iron core
4. The iron core is not cleaved and an electric wire is wound directly around the core in the form of a coil.
5. The iron core is cleaved and has cleaved edges. The core is set to a coil separately wound beforehand.
6. Shape of the cross sections of the iron core
7. Steel tapes are laminated into a band, the cross section of which makes a circle.
8. Iron core of an oblong shape or of shapes similar to it
9. Joint point of the tapes of the iron core
10. Joint points lacking
11. Each type has cut edges that make the joint site. This is an advance over that of directly underlying tape.
12. Shape of coil
13. Circular coil
14. Oblong coil

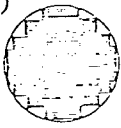
corporations: the three electric power companies Chugoku, Shikoku, and Kyushu, Chugoku Electric Manufacturing, Shikoku Transformer, Kyushu Transformer, Osaka Transformer.

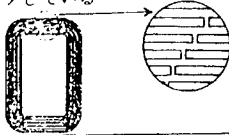
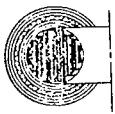
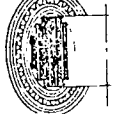
These transformers, for comparison with currently available ones, are designed in such a way that they have the same load loss. Results of the testing have proved that they have an excellent non-load loss, below one-quarter that of conventional transformers. These trial manufactured 20 kVA transformers, totaling three units, are presently being subjected to actual application tests in laboratories of the three electric power companies.

#### Recent Trend of Transformers Using Amorphous Iron Cores

Transformer manufacturers of Japan and the United States have trial manufactured a number of transformers of this type since the two countries, almost simultaneously in 1981, announced the development of such a relay transformer for practical applications. The maximum capacities in Japan are 30 kVA for single phase and 100 kVA for three phases achieved by Osaka Transformer and Toshiba, respectively. Their performance for power transmission has been verified on the basis of this trial manufacture series. Testing for long-term reliability is utilizing field power transmission lines.

In the United States, meanwhile, the Electric Power Research Institute, EPRI, and General Electric in 1983 embarked on a 3-year program of joint research for the manufacture of 1,000 units of 25 kVA transformers of this type. At the end of 1984, they invited power companies for field testing involving 800 of the 1,000 transformers produced. These are to be installed, for testing, in commercial power supply lines. This program, meanwhile, includes development of a quantity production line for these 1,000 transformers trial manufactured.

EPRI is also conducting joint research with Westinghouse for a three-phase transformer of this type. It has been reported that a three-phase, 500 kVA transformer has been completed.

In Japan, Shikoku Electric Power Co., together with Shikoku Transformer and Osaka Transformer, started in 1982 a survey of general feasibility for this type of transformer, including an assessment of the life of the transformer. The project expanded into seven company joint research in 1984 with the participant of Kyushu Electric Power Co., Chugoku Electric Power Co., Chugoku Electric Manufacturing, and Kyushu Transformer. They are pressing ahead with a project currently involving a forced deterioration test for a 10 kVA transformer and a field test for a 20 kVA unit. The Technology Research Institute of Tokyo Electric Power Co., on the other hand, embarked on the establishment of mass production technology and its evaluation in 1984.

Where development of amorphous raw material is concerned, Allied Corp. is presently shipping METAGLAS 2605 S-2, 1 inch, 2 inch, and 3 inch in width and 0.028 millimeter in thickness. It has trial manufactured a material of 170 nonometers width, and a material of 8 inch width is slated to come to the market in the near future. The corporation already has a facility capable of

producing a material of 4 inch width at an annual rate of 10,000-15,000 tons, and can hence afford to supply it in large quantities.

The material, meanwhile, is not amenable to fabrication into a laminated iron core structure due to low rigidity and the large number of steps required in processing, because a foil of the material has a thickness of only one-tenth that of silicon steel. This problem, however, is being solved by a technology development which permits lamination of 5-10 sheets of the foil. The resulting product has a thickness equivalent to that of silicon steel of 0.15-0.30 millimeters. This material may be put on the market soon under the trade name Power Core and may be treated in the same manner as silicon steel because this product is also amenable to annealing and lamination at the same time.

Amorphous materials were available at ¥40,000-50,000 per kilogram when Osaka Transformer began trial manufacture. Their price has already gone down to the level of ¥10,000 and even a price of ¥1,500 per kilogram is said to be possible providing orders are placed continually and in large quantities. As shown in Figure 2, data offered by Allied Corp. indicates that the price of the material has been falling annually and is expected to be equal to that of silicon steel by 1986 if the assessment of iron loss is included in the calculation.

#### Assessment

A number of assumptions are necessary if amorphous magnetic material for application in power transmission is to be assessed properly. Several calculations made by different institutions have led to the conclusion that the price of amorphous materials at which the transformer using that material is equivalent in value to that using silicon steel has a certain range. That is, a transformer using amorphous material is competitive with one using silicon steel if amorphous material is in a price range of one to two times the price of silicon steel. The estimations made by the author, et al., on varied assumptions have also verified this price range in most cases. The questions that confront researchers in making this estimate are largely: 1) method of estimation of the number of manufacturing steps and of the facilities required for transformer manufacture, 2) assessed values of non-load and load losses of transformers and methods of estimation, 3) selection of a transformer using silicon steel for comparisons, and, in addition, 4) assumptions of the characteristics of amorphous material cannot be ignored.

Compared with transformers using silicon steel as the core, those using amorphous material are fairly large, as shown in Table 4, providing the comparison is made with commercially available transformers with respect to the former. However, if one assumes that the assessed iron losses for both types of transformers are equal, that is, both types have a non-load loss of ¥1,000 per watt and a load loss of ¥250 per watt, the silicon steel type transformer has to be designed in such a way as to have a lower iron loss. Therefore, it must have larger size and weight. Transformers of the amorphous alloy type, therefore, need not necessarily be larger than others, providing conditions for both types are equivalent.

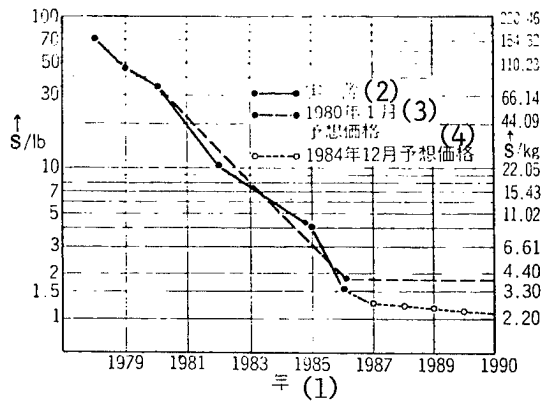

Figure 2. Trend of the Price of Amorphous Iron-Core Material

Key:

1. Year
2. Actual price
3. Price projected in January 1980
4. Price projected in December 1984

## Future Problems

Though much hope is pinned on the future of amorphous material because of its low iron loss characteristics, the basic question involved in connection with power transmission is whether the effect of energy conservation produced by the low iron loss can counterbalance the higher unit price of the material and difficulties in processing. The critical economic question is the introduction of the concept of the assessed iron loss above together with such factors as energy price, unit price of the raw material, improvement in performance of the material, and the development of processing methods. The user of the transformer, in turn, needs to be assured of its reliability on the basis of field testing. Since many organizations are pressing on with research and development in order to solve these problems, it may not be long before this type of transformer finds practical application.

## BIBLIOGRAPHY

1. Datta, et al., "Accelerated Aging Behavior of an Iron Base Amorphous Alloy for 60 Hz Application, IEEE," Vol MAG-18, No 6 (Nov 1982), pp 1391-1393.
2. Tsuchiya, "Transformers Using Amorphous Materials as the Core," JOURNAL OF ELECTRICITY SOCIETY, Vol 104 No 3 (March 1984) pp 25-32.
3. Yamamoto, et al., "Transformers Using Amorphous Materials as the Core," Research Association for Stationary Appliances, Electricity Society, SA-81-42 (1981) pp 1-10.

## Shape Memory Alloys

Tokyo KOGYO ZAIRYO in Japanese Oct 85 pp 53-57

[Article by Toshio Honma, professor of the Research Institute for the Dressing and Smelting of Ores, Tohoku University]

[Text] The fact that reports on shape memory alloys once were spotlighted in newspapers, but the fact that they have recently shown up only infrequently does not mean that popular interest has gone, but rather that knowledge of the alloy has generalized sufficiently and development of the alloy has entered the stage of commercial application.

New difficulties involved in the alloy, meanwhile, have been pointed out one after another as work on the alloy has left the stage of research and entered that of practical applications. This article deals with the present applications of the alloy and problems primarily in connection with the TiNi series of alloys which are being put to practical use. If one studies the method of improvement of the alloy's performance, one needs to learn once more, firmly and precisely, the mechanism of shape memory alloys.

## Essential Properties of Shape Memory Alloys

### 1. Martensite Transformation of the Thermoelastic Type

Shape memory effect means phenomenon observed in alloys when a low temperature phase of the alloy with a shape change produced by the martensite transformation of the thermoelastic type returns to its original high temperature phase of the original shape--a reverse transformation--with the application of heat.

Martensite transformation, in turn, means a shift from one type of crystal lattice to another in a manner comparable to that of shear-stress deformation, without involving the process of diffusion of individual atoms. In this transformation, one type produced by a very slight driving force is distinguished from the others and referred to as the thermoelastic type. It has been verified that all alloys showing shape-memory phenomenon involve this type of martensite transformation. In this type of transformation, the temperature at which an alloy begins to turn into the martensite phase of low temperature by the application of cold is denoted as  $M_s$  and the temperature at which this change is completed is as  $M_f$ . In just the same way,  $A_s$  and  $A_f$  denote the starting and terminal temperatures, respectively, at which an alloy undergoes reverse transformation into the austenite phase of high temperature with the application of heat. These temperatures vary with the composition of the alloy and hence may be controlled. Since shape memory phenomenon of an alloy starts at temperature  $A_s$  and ends at temperature  $A_f$ , it is evident that the composition of the alloy be designed so that the temperature range in which this phenomenon is to be used lies above the  $A_f$  level.

### 2. Mechanisms of Deformation and Shape Recovery for Shape Memory Alloys

Whereas the plastic deformation of metals and alloys generally involves shifts of line defects or dislocation, producing a permanent set, the shape memory alloy undergoes a unique shape change.

NICHINOL, or NiTi, the most typical of the shape memory alloy is subjected to shape change by one of the following mechanisms: 1) shape change due to growth, in the direction of priority, of martensite as induced by stress (SIM), 2) shape change due to variants tightly fitting to each other in martensite transformation, 3) shape change due to shift of twins in the martensite crystal, among other things.

Two or more modes usually take place in one shape change. In the Ti-50 at percent Ni alloy, mode 3 above takes place in the initial phase and mode 2 in the later phase, predominantly. The variants of the transformation referred to above, mean that the twin crystals of martensite grown from one matrix crystal are crystallographically identical, though their directions are different. Figure 1 presents schematically the mode of shape change 3) involving a shift of the plane of the twin in transformation and the subsequent shape memory process upon application of heat. When a specimen is made into a thin film by means of electro-polishing and subjected to a shearing strain under an electron microscope, the process of crystal change given in the figure can be observed directly.

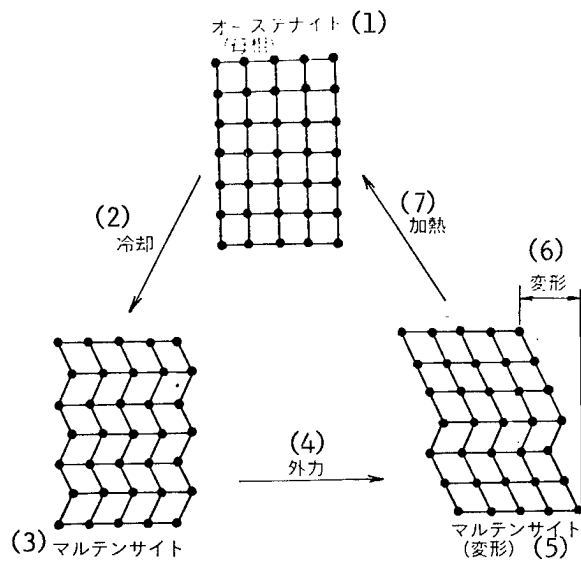

Figure 1. Diagram of the Change of Crystalline Structure in Shape Memory Action

Key:

1. Austenite (parent phase)
2. Cooling
3. Martensite
4. External force
5. Martensite (shape change)
6. Shape change
7. Heat application

This implies that the external shape change of shape memory alloys is produced by shifts of the crystal plane in the martensite phase, among other things, and disappears in the reverse process of transformation to its original phase produced by heating. A complete recovery to its original shape, therefore, may be impossible, if it has suffered an excessive shape change such as dislocations of the crystal.

It is to be noted, therefore, that complete shape-memory action is exhibited in certain range of strain, and that an excessive strain going beyond that limit necessarily leaves that excess part as the permanent set of the alloy. The limit of strain for one-dimensional tensile stress is around 7 percent.

### 3. Types of Shape Memories

The shape memory action described above is the most basic one-way type. By subjecting an alloy to special processing and heat treatment, however, it may be turned into a shape memory alloy of the two-way type capable of recovering a changed second shape in the reversible manner at room temperature.

This implies that when subjected to martensite transformation an alloy does not exhibit a martensite crystal of two different directions in equal proportion like the lower left model of Figure 1, but one with, predominantly, one special direction as shown in the lower right model.

When its temperature is lowered and reaches  $M_s$ , therefore, the alloy begins to gradually change its shape held at high temperature and regains the changed second shape of a linear form completely at temperature  $M_f$ . In effect, the alloy has two memories, gained at a high and an ambient temperature, and can change reversibly between the two. Shape memory alloys of the two-way type, therefore, permit functions like that of bimetals. However, because a complete processing method for the two-way type of shape memory alloys has not yet been established and the performance of the alloy is not yet fully reliable, and because the alloy has the disadvantage that the power of regaining the assigned shape upon cooling is significantly weaker than upon heating, the two-way type alloy has yet to find practical application and the one-way type combined with an auxiliary spring, instead, is currently being used.

It is also known that, when a piece of stress-induced martensite, SIM, is subjected to shape change at temperatures above  $A_f$ , it exhibits a phenomenon of deformation pseudo-elasticity where a major plastic-deformation strain completely disappears after the load has been removed.

More recently, it has been learned in Japan that Ti-51 at percent Ni, a high nickel-side alloy of ring form, when subjected to aging under constrained stress, exhibits a phenomenon of all-round shape memory, a very specific type of shape memory. Here, the alloy of a plate form can assume any curvature spontaneously with varying temperature, and a few application products have been put on the market.

(1) 合金系	(2) 組成	M, (°C)	A, (°C)
Ti Ni	Ti 50Ni (at%)	60	78
	Ti 51Ni (at%)	-30	-12
Ti Ni-Cu	Ti 20Ni 30Cu (at%)	80	85
Ti Ni Fe	Ti 47Ni 3Fe (at%)	-90	-72
Cu Zn	Cu 39.8Zn (wt%)	-120	—
Cu-Zn Al	Cu 27.5Zn 4.5Al (wt%)	-105	—
	Cu 13.5Zn 8Al (wt%)	146	—
Cu Al Ni	Cu 14.5Al 4.4Ni (wt%)	-140	-109
	Cu 14.1Al 4.2Ni (wt%)	2.5	20
Cu Au-Zn	Au 21Cu 49Zn (at%)	-153	—
	Au 29Cu-45Zn (at%)	57	—
Cu Sn	Cu 15.3Sn (at%)	-41	—
Ni Al	Ni 36.6Al (at%)	60±5	—
Ag-Cd	Ag 45.0Cd (at%)	-74	-80
Au-Cd	Au 47.5Cd (at%)	58	74
In-Tl	In-21Tl (at%)	60	65
In-Cd	In-4.4Cd (at%)	40	50

Table 1. Compositions and Deformation Temperatures for Various Types of Alloys

Key:

1. Alloy system
2. Composition

(1) 合金	弾性異方性 因子 (2)	母相の (3) 結晶構造	(4) すべりの発生 応力 (MPa)	破壊様式 (5)
Cu Al Ni	13	DO <sub>3</sub>	~600	粒界破壊 (6)
Cu Zn Al	15	B <sub>2</sub>	~200	粒内破壊 (7)
		DO <sub>3</sub>	高い (8)	粒界破壊 (6)
TiNi	2	B <sub>2</sub>	~100	粒内破壊 (7)

Table 2. Characteristics of Various Shape Memory Alloys and Modes of Destruction

Key:

1. Alloy
2. Elastic heterotropy factor
3. Crystalline structure of the matrix or parent phase
4. Stress for producing sliding [of crystal lattices]
5. Mode of destruction
6. Grain-boundary destruction
7. Intra-grain destruction
8. High

## Types of Shape Memory Alloys

The essential conditions for an alloy to be of the shape memory type, as referred to above, are the following: a) the alloy is capable of making a martensite transformation of thermoelastic type, b) the martensite phase is softer than the high-temperature or austenite phase, which implies that the crystal planes of twins and variants in the martensite crystal are extremely mobile and, the crystal undergoes deformation by stress less than that critical for dislocation, c) the high-temperature phase has a regular lattice structure, d) the martensite phase has a structure of low symmetry. A variety of alloys meeting the above requirements has been studied or developed. Table 1 presents a list of these alloys and their transformation temperatures.

In recent years Japan has seen development of iron alloys capable of displaying shape memory. For example, FeNiCoTi alloy, FeMnSi alloy, and FeNiC alloy have been found to exhibit this function under special conditions.

Only two types of alloys, NICHINOL (TiNi alloy) and BETALLOY (CuZnAl alloy) are practical alloys that have been put on the market to date. The CuNiAl alloy has prospects of practical applications in the near future.

Properties of the above three practical shape-memory alloys are compared in Table 2 in summary form. As can be readily seen from the table, Copper series of shape memory alloys have extremely large elastic heterotropy, which produces stress concentration at the grain boundary and development of cracks. Various methods for reducing the size of the grain boundary have therefore been advised.

### Major Properties of the TiNi Alloy

Applied products of shape memory alloys developed exclusively in Japan involve the TiNi alloy or NICHINOL at present, and the author will now look at the major properties of the alloy.

First, the properties characteristic of these alloys are: 1) a temperature at which a shape memory function takes place, 2) mechanical properties, 3) capacity for the recovery of original shape. The force acting on the alloy at the time of shape recovery is equal to the one acting when the alloy is in the low-temperature phase and with a certain amount of deformation is heated and turned into the high-temperature phase. This may be defined as the difference between tensile stress of the alloy in the high-temperature phase with that amount of deformation and that in the low-temperature martensite phase. It is given by:

$$\Delta\sigma = \sigma_H - \sigma_L$$

It is, therefore, only necessary to make the tensile test at various temperatures and to plot stress versus strain curves. Item 3) may be regarded as part of item 2).

Item 1), i.e., the temperature range at which shape memory action takes place, starts at  $A_s$  and ends at  $A_f$ , providing there is no load. It is obtained either by plotting an electric resistance versus temperature curve or by means of thermal analysis. (DTA or DSC)

The martensite transformation produced by cooling exhibits an exothermic peak while the reverse transformation by heating shows an endothermic peak, indicating temperature  $A_s$  as the leading edge and temperature  $A_f$  as the terminal. Where transformation involves two steps, as in the high-temperature phase  $\pm$  intermediate phase  $\pm$  low-temperature martensite phase, the electric resistance methods is a powerful means of recognition.

Transition from the high-temperature phase to the intermediate phase is accompanied by an acute increase of electrical resistance, and shift to the low-temperature phase is by an acute drop. Figure 2 gives the change of curves for the plot of electric resistance versus temperature after repeated cycles of cooling and heating for the Ti-50.8 at percent Ni alloy. The transformation temperature, meanwhile, shifts to the high-temperature side upon application of external stress to the alloy. One therefore needs to understand stress conditions of an alloy accurately when this is used as an actuator, and must determine experimentally the transformation temperatures of the alloy under that stress.

Figure 3 presents stress versus strain plots at various temperatures for the Ti-51 at percent Ni alloy as an example of the mechanical properties of the alloy, item 3. The upper row shows the tensile property of specimens in the martensite state and deformation disappears upon application of heat in all cases. In the intermediate row, specimens in the austenite state undergo deformation, upon application of stress, to give martensite with a priority direction, SIM. Upon removal of the stress, the specimens return to the original austenite state, the deformation vanishes, and pseudoelasticity is seen. In the bottom row, deformation involving dislocation begins, and not even heat application can remove its permanent set.

#### Present State of Applications of Shape Memory Alloys

Applications of shape memory alloys are grouped largely into two types: alloys for one single application, involving an irreversible reaction, and alloys for multiple applications, involving a reversible reaction. Both groups of applications have further subgroups that require either shape recovery alone or require the force of shape recovery as well as shape recovery. Most of the applied products of the alloy available in Japan use the force of shape recovery of the alloy in repeated cycles as actuators.

##### 1. Examples of One Single Application of Shape Recovery

This represents the simplest of applications of shape memory alloys and is a proper subject of study for those who embark on research for the first time. Artificial flowers and personal decorations like brooches are of this type, as

are the best known moon-surface antenna developed by NASA in the United States. This semispherical antenna, made by appropriately cutting and welding NICHINOL wires in the martensite phase, was folded into a small pack and sent to the moon. When set on the surface of the moon, the antenna resumes its semispherical shape and serves for communication purposes. These alloys' capacity to be placed at sites to which the transportation of bulky objects is difficult has applications not just on the moon, but in human bodies and in ultra-vacuum vessels where access by usual means is also difficult. Filters for preventing thrombosis, such as pulmonary-artery thrombosis, serve as one example.

## 2. Examples of One Single Application of Both Shape Recovery and Force Involved

This manner of application is represented by a pipe joint, which accounts for the largest proportion, by weight, of shape memory alloys used.

The joint is fabricated such that its internal diameter is slightly smaller than the external diameter of the pipes to be joined, as measured at the temperature of application. When joined, the diameter of the joint is enlarged by lowering the temperature of the joint. After two pipes are connected to the joint, they are left at room temperature such that, with the rise in temperature of the joint, the joint constricts and the pipes connect firmly. As developed by Leikem Corp. of the United States, this type of pipe joint has a very large force of constriction and works effectively, connecting pipes not amenable to welding. The joints find application in the oil-hydraulic system, etc., of F-14 jet fighters and nuclear submarines. This type of alloy finds applications also in clips, clamps, in clamping pins for steel plates, etc., and in the orifice adjuster of the carburetor of vehicles.

For medical applications, this type is put to use in rods for backbone correction, artificial joints, and bone plates of the construction type.

## 3. Examples of Repeated Applications of Shape Recovery

As often seen in science expositions and elsewhere, an exhibited artificial flower made of NICHINOL blooms and withers as either cold or warm wind is blown on it. Though it finds little practical application as yet, except in small measure in artificial hearts, in electric circuits, and in shape memory robots, there are good prospects for applications as components in large vacuum equipment.

## 4. Examples of Repeated Applications of Both Shape Recovery and Force

This type of application is found in various actuators and holds the leading share of products of shape memory alloys in Japan. Among the products developed in the United States and Britain are an automatic device to open and close greenhouse windows, temperature control valves for hot water heating of rooms, thermostats, fire exit doors, various (electric) relays, etc.

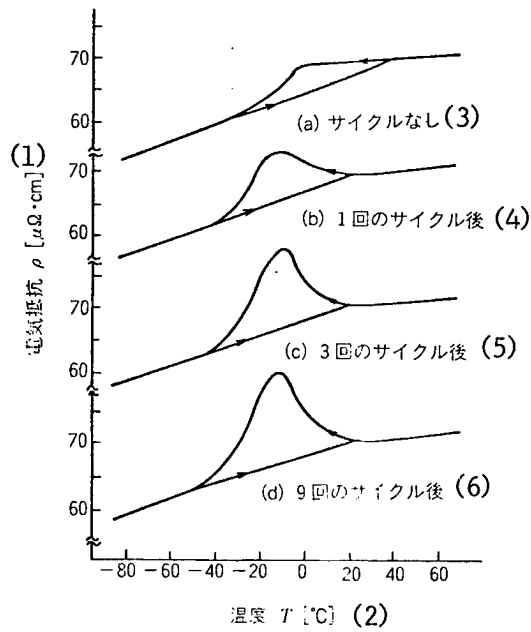

Figure 2. Effects of Heat Cycles on the Electrical Resistance of the Alloy Ti-50.8 at Percent Ni

Key:

1. Electrical resistance
2. Temperature
3. No previous cycle of cooling and heating
4. After one cycle
5. After three cycles
6. After nine cycles

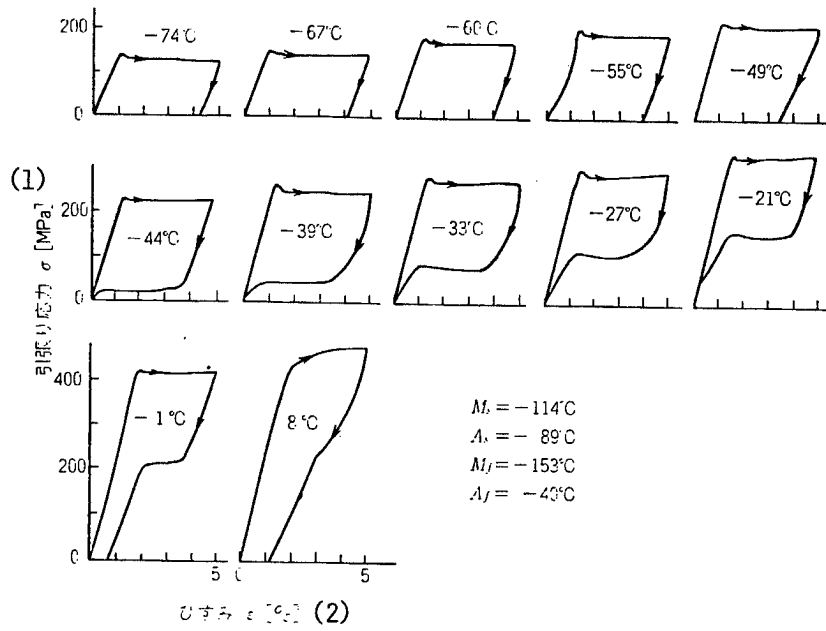

Figure 3. Plots of Stress Versus Strain at Various Temperature for the Alloy Ti-51 at Percent Ni

Key:

1. Tensile stress
2. Strain

The major products developed in Japan in order of their time of commercialization are: as actuators opening and closing automatic doors of a drying and storage warehouse referred to as "autodry" in 1982, as actuators of a damper for ventilation in microwave ovens in 1983, as adjusters of air-stream outlets for control of air-current direction in room air conditioners, also in 1983, coffee makers, in the hot water washer of flush toilets referred to as "(shawatole,)" as actuators for cold water removal, as circuit contact-point components of a simplified, portable fire alarm box referred to as "Memo alarm," all in 1984, as temperature indicating components in electromagnetic cookers "clean ranges," overheat detector "heat plugs" in 1984. These products, which have all been put on the market, are made to function in two ways, all by combining one-way shape-memory coils made of TiNi alloy wires with a bias coil, except the "memo alarm," which uses a TiNi thin plate of the all-round shape memory alloy as the circuit contact point, and which is shown diagrammatically in Figure 4.

Additionally, a robot using shape memory alloys is being developed energetically in Japan with products of trial manufacture having been successively reported in newspapers. Also in active research and development are heat engines of shape memory alloys. The turbine type, the offset crank type, and the oblique-board type of heat engines are being developed by various research organs, and basic data is being collected on each of the types.

#### Future Prospects and Problems

A wonderful alloy has been described above, an alloy capable of memorizing its shape and retrieving it upon application of heat, in connection with crystallographic reasons of this function and various examples of application. Present applications of the alloy available in Japan, however, are for the most part limited to those in which neither the temperature at which shape is recovered nor the absolute force of the shape recovery need allowance. One cannot depend fully on the material for their credibility in the case of applications where strict limitations have to be imposed on shape recovery temperatures and shape recovery forces.

This difficulty comes from the fact that a method of heat treatment which permits the material to memorize its shape has not yet been achieved. Varying conditions of heat treatment on identical material result in shifts of the temperature of shape recovery and in variations, in large measure, of shape recovery force. These properties, furthermore, are all subject to changes after repetition of heat cycles, i.e., cycles of heating and cooling, and are also affected by previous processing. The reason for these variations is that the function of shape memory alloys is involved in martensite transformation of the thermoelastic type, and, the mobility of twins in martensite crystals and that of martensite along the borders with the matrix phase are dependent largely on heat treatments, strains due to processing, etc. Standardization of the product of shape memory alloys, at any rate, needs to be set up at the earliest possible date.

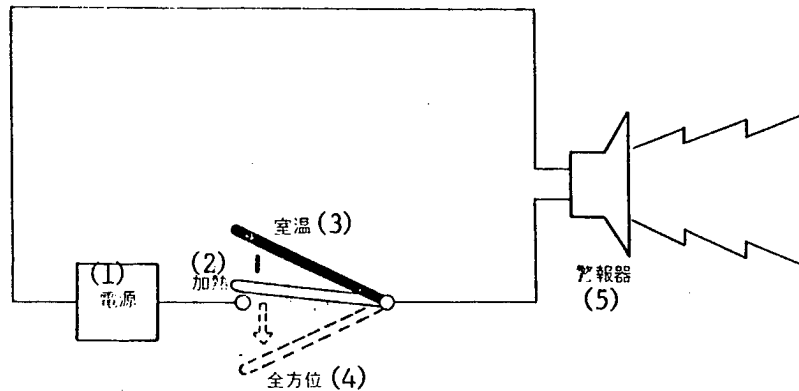

Figure 4. Fire Alarm Box, "Memo-Alarm," Using a Plate of an All-Round Shape-Memory Alloy

Key:

1. Electric power sources
2. Room temperature
3. Heating
4. All-round (in direction)
5. Alarm

This implies that experiments have to be repeated step by step and laboriously in order to establish relations between alloy compositions and heat treatments and between processing conditions and shape-recovery temperatures, shape-recovery forces, shape-recovery rates, etc. It can be expected, with elucidation of these issues, that products of shape memory alloys with greater precision, such as thermomechanical robots and automatic control machines, will be developed and will not only show up as products in the engineering sector, but also be put on the market as electric appliances, readily available to all people.

#### BIBLIOGRAPHY

1. Wayman, C.W., JOURNAL OF JAPAN METALLURGICAL SOCIETY, 19 (1980) p 323.
2. Funakubo, Hiroyasu, (editor), "Shape Memory Alloys," SANGYO TOSHO, 1984, p 53.

20,128/9599  
CSO: 4306/3574

## NUCLEAR DEVELOPMENT

### NUCLEAR INDUSTRY ACTIVITIES DISCUSSED

#### Research on KWU-type PWR

Tokyo GENSHIRYOKU SANGYO SHIMBUN in Japanese 17 Jul 86 p 1

[Text] Tokyo Electric Power plans to begin optimization research soon on a KWU type PWR [pressurized water reactor] for Japan. They have undertaken studies of the possibility of introducing a West German KWU type PWR since 1982. Plans have been firmed up to begin Phase III optimization research, based on the conclusion that "it is basically adaptable to Japan" obtained from the Phase I and Phase II studies conducted so far. Research on the design of a KWU type PWR for Japan will be conducted jointly with four companies: KWU, Hitachi, Toshiba, and Fuji Electric until March 1988. At that stage, a judgment will be made as to whether or not to proceed to the next step.

Currently, Toshiba is undertaking the development of an ABWR [advanced boiling water reactor], aiming at a more advanced BWR [boiling water reactor], but this PWR study will be parallel to that and is aimed at exploring the possibilities of multiple reactor types in the future.

However, the West German KWU type PWR has a superior record of operation and appears to have reached a globally high technology level. The regulation standards are different from Japan and it is impossible to introduce it as is into Japan.

For this reason, Tokyo Electric Power has undertaken jointly with KWU, Hitachi, Toshiba, and Fuji Electric, a study since 1982 of the possibility of introducing it into Japan.

Initially, as the first stage, a feasibility study was conducted for a year beginning in September 1982. A clarification was made of which points would require readjustment if it were introduced into Japan. A shift was made to compatibility research beginning in June 1984, as Phase II, and study was made of specific modification proposals.

As a result, the conclusion was reached that with partial modifications necessary from the aspect of quake-resistance, etc., "overall it was

applicable to Japan." Therefore, a plan has been firmed up to begin optimization research soon, as Phase III.

Based on the points for modification that have been studied so far, Tokyo Electric Power has decided to clarify with this research the basic concept of a KWU type PWR for Japan conforming to the overall plant.

Specifically, under the studies so far, it is necessary, for example, to make the concrete mat set up on the foundation thicker than that of the West German one from the aspect of earthquake-resistance. It also has been learned that the support structure for the steam generator must be stronger than the West German one. Based on these modifications, the decision was made to undertake optimization research, including domestic manufacture of instruments.

It also has been decided that study will include reduction in the amount of waste generation and considerations for the characteristically Japanese aspects of inspection and reduction of exposure.

However, since the West German type already has displayed a good record, Tokyo Electric Power plans not to add great modifications to the basic portion of the plant.

Even if introduced into the nation based on these modifications, it has been decided in this research that the goal will be a plant that is technologically and economically equivalent to an ABWR.

#### Delegation Dispatched To Soviet Union

Tokyo GENSHIRYOKU SANGYO SHIMBUN in Japanese 17 Jul 86 p 1

[Text] The Japan Atomic Industrial Forum (JAIF) held the fifth Japanese-Soviet Atomic Energy Cooperation Delegation Conference, scheduled from 10 to 19 August in Moscow, with the Soviet State Committee for Utilization of Atomic Energy (A. Petros'yants, chairman). They also toured related facilities.

The JAIF signed "an agreement to cooperate in the peaceful use of atomic energy" with the Soviet State Committee for Utilization of Atomic Energy in November 1977. Cooperation has been promoted by the mutual holding of 13 joint seminars in both countries on such themes as development and operational experience with light water reactors and uses of radiation.

Since the policy decision on these programs of cooperation has resulted in the continued mutual holding of conferences by the Soviet Union and Japan with delegates from both sides, the JAIF established a Japanese-Soviet Atomic Energy Cooperation Liaison Committee (committee chairman: Tomiichiro Shirasawa, JAIF vice chairman, Overseas Electrical Industry Survey Institute chairman) to handle them.

For 2 days out of the schedule, this fifth delegates' conference studied the 1987 program of cooperation, details of the seminar scheduled to be held this

year, and plans and current status of development of atomic energy by both the Soviet Union and Japan.

Also, an exchange of opinions was made concerning the Chernobyl nuclear power plant accident.

The JAIF sent eight delegates with Vice Chairman Shirasawa as head of the delegation. In addition to Vice Chairman Shirasawa, there were the following:

Masatoshi Toyoda, vice president of Tokyo Electric Power; Yoshikazu Yoshida, chief, Tokai Research Establishment Health Physics Department, Japan Atomic Energy Research Institute; Hiroshi Kurihara, deputy chief, Power Generation Management Department, Japan Atomic Power Company; Kazuhisa Mori, managing director, JAIF; Shigekazu Yoshijima, Toshiba Atomic Energy chief engineer; Hiroshi Ito, Sumitomo Corp Soviet Office secretary; Masakazu Menju, head, General Affairs Department, Overseas Electrical Industry Survey Institute.

#### Chinese Tour Nuclear Fusion Facilities

Tokyo GENSHIRYOKU SANGYO SHIMBUN in Japanese 17 Jul 86 p 1

[Text] Four Chinese nuclear fusion experts came to Japan on 13 July for about 2 weeks to tour Japanese nuclear fusion-related facilities at the invitation of the Nagoya University Research Institute of Plasma Physics and the Japan Atomic Industrial Forum (JAIF).

The group of four was headed by Huo Yuping, director of the Chinese Academy of Science Plasma Physics Institute who had conveyed his desire to visit Japan to Taijiro Uchida (director, Nagoya University Research Institute of Plasma Physics), head of the nuclear fusion China visit delegation sent by JAIF to China in summer 1985.

Tokamak research is the mainstream of Chinese nuclear fusion development. Currently, they are proceeding with forming a foundation based on long-range prospects. Tokamak research chiefly is conducted at the Xinan Physics Research Institute and Plasma Physics Research Institute. A total of about 1,000 researchers in all are employed at both.

Two medium-size Tokamaks (HLQ-1 and HT-6M) already have been completed and they now have moved from adjustment testing by Joule heating to research testing by rated operation. The HLQ-1, which was built over a long period of time after design in a rather short time, is now under adjustment testing and a remodeling program is now proceeding to upgrade equipment functions.

The HL-6M [as published], a recent design compared to the HLQ-1, appears to have smoothly entered the stage of implementing additional heat by applying various types of measurement rules, but a definite need has been expressed for research exchange with nearby Japan.

While in Japan, the group visited university-related nuclear fusion development facilities, atomic power manufacturers, and national testing research agencies.

## Reverse Magnetic Field Pinch Device

Tokyo GENSHIRYOKU SANGYO SHIMBUN in Japanese 17 Jul 86 p 2

[Text] The Electrotechnical Laboratory recently began preliminary testing of the TPE-1RM15 high performance reverse magnetic field pinch device. The device is a scaled-up version of the TPE-1R(M), which achieved the highest value in the world. Full-scale tests will begin about the middle of September after installing a plasma position control device.

In a fusion reactor, use of a deuterium-deuterium (D-D) reaction or a deuterium-tritium (D-T) reaction is considered.

However, in order for these reactions to occur easily and extract practical energy, the core gas temperature must be heated to about 600 million degrees for a D-D reaction and 100 to 200 million degrees for a D-T reaction. At the same time, the density of the high temperature plasma state gas and the volume during the period of confinement (Lawson number) must be high.

In this way, a "break even" is realized for the first time in which the energy generated by the nuclear fusion reaction and the energy injected to continue the reaction become equal.

Also, if a 100 million degree temperature and a Lawson number of 10 to the 14th power particles per cubic centimeter a second is realized with a D-T reaction, "self-ignition" is possible in which the reactor can be continually operated by the energy generated from the fission reaction alone.

The Tokamak realizes the plasma parameters closest to this ignition. Currently it is approaching a highest temperature of 0.3 to 0.8 hundred million degrees and its Lawson number is  $5 \times 10$  to the 13th power particles per cubic centimeters a second.

However, the reverse magnetic field pinch (RFP) method has been noted because it theoretically can conduct ignition with electric current alone, as opposed to the Tokamak which requires not only current, but a neutron particle injection device and high frequency heating device to reach the critical plasma conditions.

The Electrotechnical Laboratory already is doing tests with the TPE-1R(M) (donut radius, 50 cm; plasma cross section radius, 10 cm) and has great confidence in it.

The TPE-1RM15, which has now begun preliminary testing, is a further scale-up with a donut radius of 70 centimeters and plasma cross section radius of 15 centimeters.

The preliminary tests started at the beginning of the year and favorable results have been obtained at the present point in time. For the future, it has been decided that full-scale testing will begin around September after installation of attached devices.

The RFP method resembles the Tokamak in the point of confining plasma from outside through a magnetic field but in this case, confinement performance is upgraded by reversing the direction the current is flowing, and forming a line of magnetic force in the opposite direction within the plasma.

Parallel to these tests, the Electrotechnical Laboratory is conducting general systems detailed design research on the TPE-RX, aiming at a further scale-up.

12256

CSO: 4306/2104

END