

282092

JPRS-JST-86-027

12 SEPTEMBER 1986

Japan Report

SCIENCE AND TECHNOLOGY

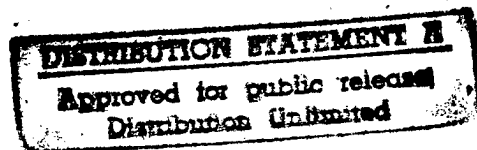

DTIC QUALITY INSPECTED 2

19980218 143

FBIS FOREIGN BROADCAST INFORMATION SERVICE

19
58
A04

NOTE

JPRS publications contain information primarily from foreign newspapers, periodicals and books, but also from news agency transmissions and broadcasts. Materials from foreign-language sources are translated; those from English-language sources are transcribed or reprinted, with the original phrasing and other characteristics retained.

Headlines, editorial reports, and material enclosed in brackets [] are supplied by JPRS. Processing indicators such as [Text] or [Excerpt] in the first line of each item, or following the last line of a brief, indicate how the original information was processed. Where no processing indicator is given, the information was summarized or extracted.

Unfamiliar names rendered phonetically or transliterated are enclosed in parentheses. Words or names preceded by a question mark and enclosed in parentheses were not clear in the original but have been supplied as appropriate in context. Other unattributed parenthetical notes within the body of an item originate with the source. Times within items are as given by source.

The contents of this publication in no way represent the policies, views or attitudes of the U.S. Government.

PROCUREMENT OF PUBLICATIONS

JPRS publications may be ordered from the National Technical Information Service, Springfield, Virginia 22161. In ordering, it is recommended that the JPRS number, title, date and author, if applicable, of publication be cited.

Current JPRS publications are announced in Government Reports Announcements issued semi-monthly by the National Technical Information Service, and are listed in the Monthly Catalog of U.S. Government Publications issued by the Superintendent of Documents, U.S. Government Printing Office, Washington, D.C. 20402.

Correspondence pertaining to matters other than procurement may be addressed to Joint Publications Research Service, 1000 North Glebe Road, Arlington, Virginia 22201.

JAPAN REPORT
SCIENCE AND TECHNOLOGY

CONTENTS

DEFENSE INDUSTRY

- Active Microwave Radar Systems Analyzed
(Junichi Kimura, et al.; BOEI GIJUTSU, Feb 86)..... 1

NEW MATERIALS

- New Materials-Related R&D Reported
(NIKKO MATERIALS, Mar 86)..... 7
- Nonoxide-Based Ceramics Bonding Discussed
(Nobuyuki Tamari, Minoru Kinoshita; NIKKO MATERIALS,
Apr 86)..... 17

NUCLEAR DEVELOPMENT

- Plutonium Use in Future of Nuclear Power Discussed
(Shoji Nomoto; PUROMETEUSU, Nov 85)..... 27
- JAERI, Universities Strengthen Research Cooperation
(GENSHIRYOKU SANGYO SHIMBUN, 3 Jul 86)..... 33

SCIENCE AND TECHNOLOGY POLICY

- Law Promoting Research in Specified Biological Industries
(TOKI NO UGOKI, 1 Jul 86)..... 35

SENSOR TECHNOLOGY

Research on Optical IC Sensor Reported
(Masamitsu Haruna; KINO ZAIRYO, Feb 86)..... 43

/12223

DEFENSE INDUSTRY

ACTIVE MICROWAVE RADAR SYSTEMS ANALYZED

Tokyo BOEI GIJUTSU in Japanese Feb 86 pp 20-24

[Article by Junichi Kimura, Guided Missile Office, Third Research Center, Technical Research and Development Institute (TKDI), Defense Agency; Ryuicha Takeda, First Department, Third Center, TRDI; Yuhkichi Fujimatsu, Test Section, Gifu Test Center, TRDI; and Toshiyuki Kato, Air Proving Wing, Air Self-Defense Force: "Feasibility Study of Airship for Military Use, Part 6"]

[Text] (4) Sea Surveillance

The purpose of sea surveillance is continuous observation of the movement of vessels on the oceans of the earth. The United States has continued marine monitoring work using artificial satellites since 1976. When operations are controlled, it is necessary to check the position of friendly as well as enemy fleets. This work can be easily carried out to required levels even using present technologies. We describe here the active microwave radar systems employing microwaves with much longer wavelength than that of visible infrared regions.

Microwave Radar System

A video system employing active radar technology can be cited as a practical microwave radar system. This system can be broadly classified into two types, i.e., SLARS (side-looking airborne radar system) employing a real aperture antenna, and SARS (synthetic aperture radar system). In either case, the ground surface is irradiated with radar equipment, and the energy of microwaves returning as scattered waves is observed. In order to do this, the active system must have a transmitter which irradiates electromagnetic waves, and a sensor which receives reflected electromagnetic waves. Therefore, a microwave antenna is used in the active system.

The ground surface resolution capacity of radar images poses problems. First, the radar beam must be extremely sharp, and the pulse width must be sufficiently short. In addition, the directivity of a receiving antenna, which observes the reflected waves, must be sufficiently sharp. Theoretically, this is related to the size of the antenna, that is, D :aperture and λ :wavelength. In conclusion, it relies completely on the parameter of D/λ . The larger this value is, the sharper the radar beam becomes, and the more the ground surface resolution capacity is enhanced. The system where the

antenna aperture D is larger than the wave is called "real aperture radar system. On the other hand, the aperture is enlarged effectively in combination with data processing, but the actual antenna itself is not so large. This is called "SARS." Figure 40 shows the principle of a real aperture radar system.

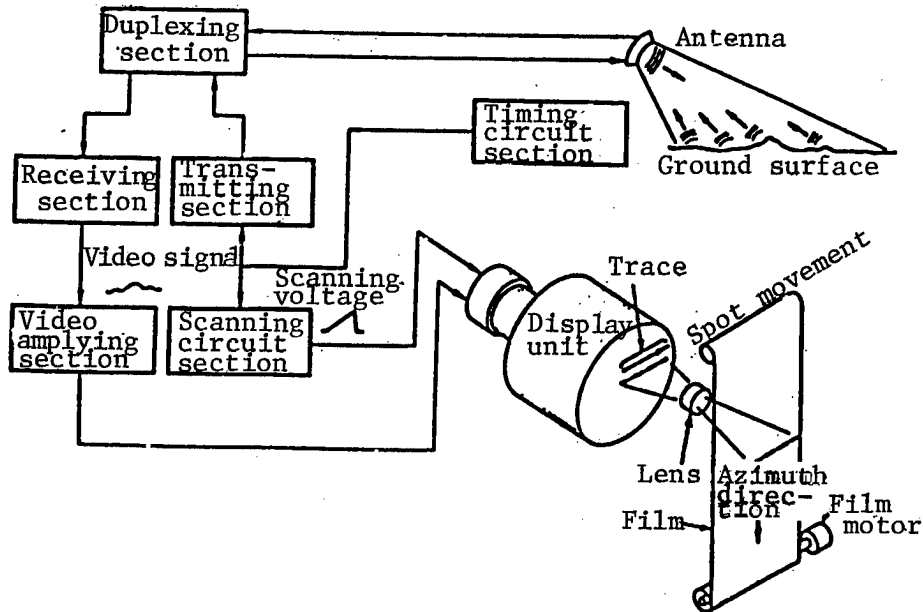

Figure 40. Concept of SLARS (Side-Looking Airborne Radar System) (by MARS Aerial Remote Sensing Co., Ltd.)

Resolution capacity is considered by dividing it into two portions, i.e., an azimuth direction of platforms on which a system is loaded and a right angle direction (range direction). Figure 41 shows the range direction. The pulse of the transmitted radar waves is reflected from the ground surface, but in order to clearly observe reflections for respective targets, the pulse width for their intervals must be sufficiently short.

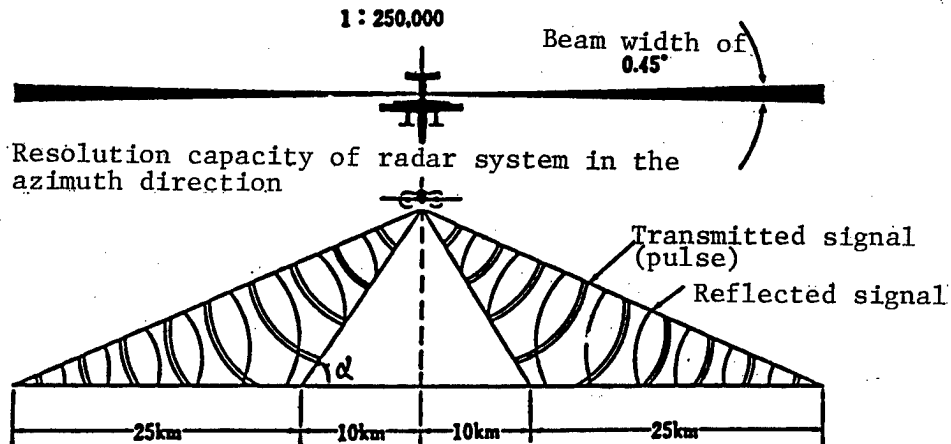

Figure 41. Resolution Capacity of Radar System in the Range Direction (By MARS Aerial Remote Sensing Co., Ltd.)

Basically, the resolution capacity in the range direction depends on pulse width and pulse duration. Also, it relies on wave incident direction. Considering that the relation between them is based on the reciprocation of wave reflections, the resolution capacity, R_r , in the range direction can be expressed as:

$$R_r \doteq (\tau C)/(2 \cos\alpha)$$

where, τ = pulse duration, C = traveling speed of electromagnetic waves in the air, and α = magnetic dip at the time an object is seen from an antenna. The smaller τ is and the smaller magnetic dip α is, the R_r becomes smaller and resolution capacity becomes greater. Therefore, usually, the ground surface is irradiated with radar equipment at an angle inclined to some extent, because shadows formed properly on radar images will clarify the terrain and objects. The name of SLAR comes from this.

On the other hand, the resolution capacity in the azimuth direction, that is, the track direction, relies on the antenna aperture length. The larger the antenna aperture, the better, because the narrower the beamwidth, the higher the resolution capacity. The resolution capacity, R_t , in the track direction depends on the distance between beam angle and antenna. The beam angle is given by the following equation: λ/D (rad), where λ = wavelength, and D = size of antenna. The resolution capacity, R_t , in the track direction depends on the following equation:

$$R_t = (\lambda S)/D$$

where, S = distance between antenna and object.

As shown in the above equations, the resolution capacity in the track direction is completely different from that at a right angle to the track direction. Particularly, the resolution capacity in the track direction related to the size of antennas, is lowered in accordance with the distance from an observation point. When ka band systems of the real aperture SLAR with a wavelength of 0.86 cm are used, the resolution capacity is about 35 m at a distance of 20 km in the case of an antenna length of 4.9 m. On the other hand, when the pulse width τ is 0.1 μ s, and the magnetic dip is 50 degrees in the range direction, the resolution capacity is 23 m. When the wavelength for both cases is the same, the parameters important for performance of the real aperture radar system are the pulse width of microwaves and antenna aperture length.

SARS

In SARS, the resolution capacity in the track direction does not depend on the distance from an object. The reason is explained below. As shown in Figure 42, when microwaves with a certain beamwidth irradiate object A, the object will be irradiated continuously while the microwaves move distance (L) equivalent to the beamwidth on the ground surface. When data is collected continuously and information is processed using the collected data during the above period, a result equivalent to that obtained by using an antenna

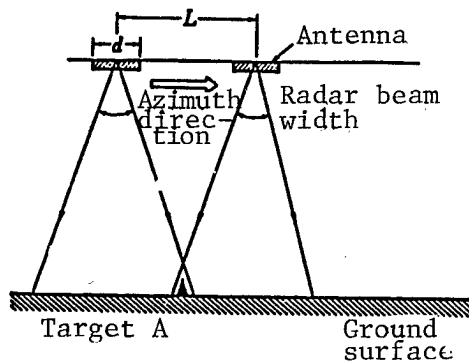

Figure 42. Principle of SARS (Synthetic Aperture Radar System)

with a length of L can be virtually obtained. As previously mentioned, the resolution capacity of the SARS does not depend on the radar range. Therefore, this system is a must when observation work is carried out from a very long distance, for example, radar systems mounted on artificial satellites, etc.

Theoretically, the philosophy of SARS is similar to that of CDP (common depth point stacking), which is a technology on seismic reflection method. A kind of holography is used in SARS. Holography is a method where results obtained by making received signals interfere with an electrical signal, which is a reference signal, are recorded. On the other hand, the range direction for both real aperture radar systems and SARS is the same. Therefore, reflections which incite from the ground surface together with the elapse of time, are recorded consecutively or scanned orderly on the CRT (cathode-ray tube) in accordance with the progress of the platform of aircraft, etc., in the same way as the real aperture radar system.

It seems that the real aperture radar system is optimum as a microwave radar system which can be used for sea surveillance.

(5) Summary

Finally, various systems are compared with each other with a view to summarizing the contents of electronic equipment which will be mounted on strato-flying airships.

Table 16 shows the weight of units mounted on such airships, power consumption, and roughly estimated price. With regard to the early warning radar system and antisubmarine radar system, their prices estimated in fiscal 1983 are shown in the table. Also, with regard to sea surveillance, a rental charge of the U.S. artificial satellite remote sensing system is shown for reference.

The payload of an LB type stratoflying airships introduced as an example for designing this system, is 300 kg. The units shown in Table 16, which can be presently mounted on such airships, are the antisubmarine patrol infrared

Table 16. Weight, Power Consumption, and Price of Units To Be Mounted on Airships

Mission	Unit which will be mounted on airships	Weight (kg) and power consumption (kw)	Price (¥1 billion)
Early warning	Early warning radar equipment	750 kg 50 kw	About 3.6
Antisubmarine patrol	Infrared sensor	227 kg 0.32 kw	About 3.5
	Antisubmarine radar equipment	600 kg 50 kw	
Communications relay	Pentadirectional multiple relaying unit	210 kg 0.2 kw	About 0.1
	Multidirectional small capacity relaying unit	300 kg 3 kw	
Sea surveillance	Microwave radar equipment	750 kg 1 kw	(About 1) (see note)

Note: () means rental charges of the U.S. artificial satellite remote sensing system

sensor and communication repeater. In order to mount other units on these airships, the airships must have a larger capacity, or these units must be miniaturized and lightened.

5. Conclusion

The history of airships and the research on recent systems were surveyed in technical outline for feasibility studies of airships for military use. This was published serially in DEFENSE TECHNOLOGY over six issues, and a system of airships suitable for defense purposes was designed in order to carry out the selection of operational conditions for defense purposes and a definite study on these conditions. As a result, the following conclusions have been drawn.

- (1) It has been learned that compared with aircraft and artificial satellites, airships are in a unique position. The stay of airships in the stratosphere over a long period of time will bring about the best use of the capacity of these airships.
- (2) As a result of comparing the system design of electric propulsion cruising airships employing a lifting body with that of conventional airships manufactured in the past for the same purpose, it is confirmed that the former design system is superior to the latter one.
- (3) It is possible for stratostaying airships, based on systems design, to stay at an altitude of 20,000 m in Japan throughout all seasons, even under high-altitude meteorological conditions.

(4) Early warning units, antisubmarine units, communication repeaters, sea surveillance units which will be mounted on airships, weight, power consumption, etc., have all been thoroughly studied, and those optimum for respective operational purposes have been selected.

(5) As a result of additional study of the fragility of stratostaying airships, it appears possible for the airships to have unexpected resistance to fragility. In addition, they may well be resistant to sudden attack.

20,143/9365

CSO: 4306/2554

NEW MATERIALS

NEW MATERIALS-RELATED R&D REPORTED

Tokyo NIKKO MATERIALS in Japanese Mar 86 pp 24-29

[Text] Ceramics

Ceramics Coating by Laser Sintering

Nichiban Laboratory has developed ceramics membrane sintering technology that uses carbon dioxide gas laser.

Conventionally, ceramics membrane such as enamel has been made by sintering in a furnace, but with this method the base material itself is heated, making it difficult to apply to materials with low melting points, such as cement and plastics.

With the newly developed technology, a carbon dioxide gas laser is set above the conveyer belt so that radiation is directed on the base materials moving on the conveyer sintering the coating material on the base. This method can be used for any type of base material and makes it instantly possible to form ceramic membrane of even quality.

While conventional ceramics coating agents can be used for the new process, the company has developed an alkoxide coating agent specifically for laser sintering.

Crystal Glass With Highest Transparency and Hardness

Nippon Sheet Glass Co., Ltd., has established the technology to produce crystal glass which features not only transparency and hardness at the highest level in the world, but also exhibits zero expansion coefficient. The company intends to make full-fledged efforts to develop the market for this new glass.

Crystal glass is generally produced by heat-treating formed glass at a temperature around 800°C. The conventional products, however, had drawbacks of containing foams and having colors.

For the new product, silica, alumina, and lithium oxide are used as primary ingredients. They are combined to evenly melt at around 1,550°C and zirconia and titanium are added as nuclear forming agents to promote crystallization.

By strictly controlling temperature, fine crystals of 200Å are realized and transparency of the finished glass has been improved by 10 percent from conventional products.

Also, by precisely controlling the alkaline concentration of the raw materials, and by immersing them in high-temperature nitrate solution to exchange sodium ions in the glass for potassium ions in the solution, the surface hardness has been improved by about 10 percent (Vickers hardness 900-1,000).

The company expects applications of this new quality glass in wristwatch cover glass replacing sapphire, and in IC photomask substrate.

Super-Thin Ceramic Film Continuously Produced by Chemical Synthesis

Mitsubishi Mining & Cement Co., Ltd., has developed the technology to continuously produce 30-100 μ super-thin ceramic film. The company has commissioned Research Development Corp. of Japan to develop this and its achievements are expected to be a major contribution to further sophisticated IC's and LSI's.

The new technology chemically synthesizes the film by applying the sol/gel method to aluminum alkoxide produced from metal aluminum and alcohol. The process makes it possible to produce film with a thickness one digit smaller than conventional ones, while maintaining the properties of alumina ceramics.

This new method eliminates conventional production processes dealing with powders, i.e., pulverization, presintering, and classification, and conducts the whole operation with the material in liquid form. Thus, there being no process where impurity contamination is possible, the method features production of uniform high purity/density products.

The company expects the demand for the film to increase rapidly in the fields of satellite broadcasting, and packaging IC's and transistors.

Shock Resistant, Low Price, Ceramic Ink Roll

Fuji Chemical Paper Industry, in cooperation with Filton, has developed an ink roll made of ceramics and has started full-fledged marketing.

The ink-roll, used in electric calculators and cash registers, is presently made of nylon 66 or polyethylene. Compared with conventional products made of these soft materials, the new ink roll uses ceramics to achieve high shock resistance and high density ink application. In addition, the ceramic ink roll is suitable to mass production, resulting in costs at one-half conventional products, according to the company.

Also, it is possible to produce long roll, whose practical application has been so far considered difficult. Fuji Chemical Paper has already produced trial products which correspond to A4 format and obtained the data of Young's modulus (elasticity rate) as 6×10^3 per 1 mm^2 .

Joint development was carried out with Filton, engaging in ceramics material research, and Fuji Chemical Paper, conducting studies on ink, over the past 2 and 1/2 years before the new product was commercialized.

Metals

Fluid Bed Furnace for Heat Treatment of Metals Achieves High Temperature of 1,250°C

Toray Engineering has developed a high-temperature furnace to heat-treat metals using fluid bed technology which can achieve a maximum temperature of 1,250°C. In developing and commercializing standard models for a temperature range of 600-1,200°C, the company succeeded in developing a furnace that can be heated up to 1,250°C, the temperature which exceeds the range of the ordinary fluid bed furnace.

Shafts, gears, springs, and other iron/steel and plastic parts used for automobiles and machinery are usually heated at temperatures of 500-1,200°C and then quenched or immediately cooled to strengthen the surface or to harden the substance.

Salt bath, atmospheric furnace, or vacuum furnace has often been used for heat treatment, but they have problems regarding operation environment, safety, and maintenance.

The newly developed high-temperature furnace operates as follows. Alumina, as the fluid heat medium, is used to fill a metal container. The container is heated by a heater installed inside or around the container, and air or another gas is fed into the container to make the alumina expand and become fluid. The metal to be treated is inserted in the fluid bed, directly or placed in a container such as a basket, and subjected to heat treatment.

Using a mixture of air, nitrogen, or nitrogen gas-based natural gas, methanol steam, and propane, as the atmospheric gas, the new furnace features outstanding controllability and uniformity of the inside temperature, as well as swift heat conductivity and quick temperature rise. Also, it is nontoxic, pollution free, and corrosion resistant.

The company expects the new furnace to be used for the heat treatment of surface hardening of nitriding steel, and in the field of die production.

4-Inch Diameter, Nondislocation GaAs Crystal

Mitsubishi Monsanto Chemical Co., in cooperation with Mitsubishi Chemical Industries Ltd., has developed a nondislocation, nongrowth stripe GaAs crystal with a diameter of 4 inches, the size comparable to the diameter achieved by silicon crystals.

The technology to mass produce 3-inch diameter nondislocation crystals was already established by Mitsubishi Monsanto. The company developed this technology by further improving its crystal breeding furnace and automatic

diameter control technique and by applying VM-FED technology, and realized the 4-inch diameter with In addition in an amount equivalent to the 3-inch product.

Since dislocation in GaAs crystal cause defective properties of LSI devices, their elimination has been desired to improve integration. In view of stress in the crystal, considered as dislocation generator, becoming stronger as diameter becomes larger, the general method to improve integration is to increase the amount of In addition or to moderate the heat environment for lower temperature gradient.

Increasing the In amount to be added, however, has the drawbacks of causing uneven concentration and lowering yield.

The newly developed technology solves such problems and exhibits dislocation density of 50 dislocations per cm^2 for the whole surface of a 4-inch wafer, without causing In concentration difference. Also, the dispersion of the ion-infused layer is no more than 4 percent, a value similar to the 3-inch crystals. Thus, the quality of this large-diameter crystal shows values close to the best of LSI materials.

Metal Sprayed FRP With High-Shielding Effect and Improved Bonding Ability

Nippon Shokubai Kagaku Kogyo has developed metal sprayed FRP (fiber reinforced plastic) and has embarked on cultivating the market.

Currently, metal and FRP are bonded together using epoxy adhesives; however, this process has a drawback in that the bonded pieces come off easily. To solve this problem the company has developed a bonding technology using the metal spray process by which metal and FRP are put together by an intricate boundary where high bonding strength--stronger than the FRP mother material--is achieved.

By means of this bonding technology, a thin layer of metal can be formed on the surface of the FRP and it is possible to finish the surface smooth or rough without performing after-work on the surface.

Recently, following the advance of IC and LSI in electronic equipment, devices are being sought to protect them from noise generated by the equipment or noise outside the equipment. In order to achieve the noise-shielding effect, post-molding zinc spray has been employed but this method has the disadvantages of complicated process and weak adhesive strength. On the other hand, the metal-sprayed FRP method makes it possible to conduct FRP molding and metal film coating simultaneously and can turn out products with excellent shielding effect and adhesion strength.

According to the company, development of this new FRP will contribute to improve rigidity and abrasion resistance. Since the metal-sprayed FRP can achieve the same bonding rigidity as metals with one-half the weight of the metals, the company expects applications will develop in new fields of building materials and tanks.

Cendust Alloy Made Into 0.4 mm Thin Plate

The Institute of Applied Magnetism has developed the hot roll process to work cendust alloy into 0.4 mm thin plate.

Cendust alloy is an iron alloy which contains 10 percent silicon and 5 percent aluminum. Because of its high permeability, excellent abrasion resistance, and capability for high density recording, this alloy is drawing attention as a new material to be used in magnetic heads. Practical application, however, has been hindered by disadvantages common to new alloys, i.e., difficult workability and low yield.

The new process comes in two types, press and roll. In both methods the tools and the materials are heated to the temperature range where sufficient extensibility can be exhibited. Devices are implemented to keep the surface and the inside of the material at the same temperature during the work, thus eliminating cracks and pores unavoidable with conventional heat roll and making it possible to produce quality thin plate. The institute also has developed a special heat resistant material to be used for press tools, and realized non-warp thin plate of 0.4 mm in thickness by press process and 0.2 mm in thickness by roll process. In addition, the institute says it is possible to produce cendust foil by polishing the thin plate.

Super Lightweight Multifunction Foam Aluminum

Shinkou Steel Wire Industry, in cooperation with the Government Industrial Research Institute in Kyushu, an affiliate institution of the Agency of Industrial Science and Technology, has developed foam aluminum "Arupoterasu" (brand name) with specific gravity of 0.2-0.3--1/40 as light as iron--and with multiple functions.

Currently, foam aluminum has been studied in and outside of Japan as a lightweight multifunction material, but has not been practically applied due to the difficulty in producing uniform quality products and because of its high cost.

The new material, made by adding a thickener and foaming agent to molten aluminum, comes in uniform quality and can be made in large size.

This aluminum features not only ease in machine work, such as cutting and bending, but also: 1) high sound-absorbing effect at low frequency region; 2) excellent corrosion resistance, heat resistance, and shock resistance; and 3) heat insulation effect comparable to marble, and electromagnetic wave-shielding characteristic equivalent to aluminum plate.

The new material has a wide range of applications, including construction materials, noise prevention material, electromagnetic shielding material, and materials for parts for cars and ships.

High-Speed Continuous Coating of Lead Frame

Research Development Corp. of Japan has developed "IC packaging material, high-speed continuous coating technology" to coat semiconductor lead frame with aluminum continuously at high speed. The development commissioned by the corporation to Sumitomo Electric Industries, Ltd., is a result of the study by Prof Yoichi Murayama of Toyo University.

Lead frame sends out electric signals of the semiconductor. At present iron, nickel alloy, and copper are used, and plated gold or silver or aluminum belt is pressed for wire bonding. The conventional processes, however, have drawbacks in that aluminum belt, coated lead frame can provide terminals only in two directions, while precious metal plated lead frame lacks reliability.

The newly developed technology uses a high frequency ion-plating process to spot-coat aluminum on long reel tape of lead frame. This process allows providing terminals in four directions and exhibits excellent adhesion characteristics between aluminum and substrate, wire bonding, and sealing upon package-assembling, making the product highly reliable. In addition, it has become possible to perform continuous coating by controlling position deviation at 0.2 mm or less at a speed of 50 cm/minute. The established new technology contributes to widely reduce the size and cost of IC's.

Sanki Engineering and Delta Research Start Working on Amorphous Alloy Products

Sanki Engineering Co., Ltd., in cooperation with Delta Research, has started work in the field of plating and secondary work of amorphous alloys.

Amorphous metals, being noncrystalline with their atomic configuration disorderedly and without the crystal structure of ordinary metals, have characteristics of excellent corrosion resistance, strength, and magnetic properties. These materials, however, have not been used widely in the market because of the limited width and thickness of the commercial products and due to their difficult workability.

The two companies have succeeded in greatly improving the workability of amorphous metals by conducting special surface treatment when plating is performed to prevent amorphous metals from causing hydrogen embrittlement. The new material thus produced not only allows soldering, which cannot be performed on conventional amorphous metals, but also accepts slit forming and etching work, according to the companies.

Sanki Engineering intends to produce electromagnetic wave-shielding materials such as sheet panels, blinds, and tapes, as well as pressure sensors. The company's plant will start operation in December 1985 with a production capacity of 3 tons per month, which is planned to be increased to 10 tons as of the latter half of 1986. After growth of business in the future, the two companies will consider establishing a joint venture company specializing in this business.

High Extensibility, Super Strength Steel Plate With Tensile Strength of 100 kg/mm²

Kobe Steel, Ltd., has developed "high extensibility, super strength steel plate," with tensile strength as high as 100 kg/mm², that exhibits excellent workability and high extensibility. Sample shipment of the new steel plate is underway.

Steel plate for automobiles is becoming increasingly thin to comply with the requirement of light weight, and improvement in tensile strength per unit space of reinforcing bar is also sought after.

The new steel, developed to meet these requirements, is made of iron base with 0.15 percent carbon, 1.52 percent silicon, 2.03 percent manganese, 0.014 percent phosphorus, 0.001 percent sulfur, and 0.054 percent aluminum added. The steel is made by the same production process as existing 60-80 kg steel: 20-mm thick steel slab prepared by hot gross roll is hot pressed into 3.2-mm thickness with the finishing temperature of 910°C and rolling temperature of 560°C before cold pressing into 0.8-mm thick plate. Continuous annealing is conducted by applying gas jet on the steel plate heated to 200-950°C, cooling it at a speed of 15°C/sec until the temperature comes down to 450-400°C, and then water quenching the plate to increase its strength.

Compared with 60-80 kg steel, the new steel contains more silicon and manganese to fix free carbon in the steel. Also, water quenching makes the crystals of the materials smaller and unified in size. Another feature of the new steel is that press forming can be conducted owing to its workability and extensibility being in the order of existing 80-kg class compound tissue steel plate.

Plastics

U.S.-Made Artificial Skin Marketed: Effective in Burn Treatment

Japan Bireen has received the Health and Welfare Ministry's approval on "Biobrane," an artificial skin the company had been importing from Woodroof Laboratories of the United States and marketing on a trial basis, as a specified medical treatment material applicable to health insurance. Bireen will now start nationwide marketing.

"Biobrane" was developed by Woodroof in 1979 as a biologically synthesized skin alternative. This artificial skin is comprised of ultra-fine nylon made by bonding high density collagen peptide--an intermediate substance between protein and amino acid--and silicon membrane. Its characteristics of being thin, pliant, elastic, and enzyme insoluble make it suitable for treating burns.

Its price of ¥26,000 per 30 cm² is less expensive than other artificial skins by about 50 percent because "Biobrane" rarely requires replacement.

Taking advantage of "Biobrane's" characteristics, the company plans to proceed with development of a coating material to treat loss of whole skin layers.

Super-High Polymer Polyethylene With Superior Abrasion and Shock Resistance

Japan Petroleum Chemical has developed a polyethylene with super-high molecular weight which shows abrasion and shock resistance superior to engineering plastics. The company will develop applications of this new material and market it in the form of finished goods.

The special resin, whose mass production technology has been established by Japan Petroleum Chemical by combining the company's own polymerization process with the catalysis technique, has an extremely large molecular weight of 2.5-4.5 million (molecular weight of high density polyethylene is 20,000-200,000). Because of this, the resin features abrasion resistance more than five times larger than fluorine resin, and shock resistance larger than engineering plastics. Another feature is that strength does not decline at low temperature. On the other hand, it has a disadvantage of low melting point at around 130°C, making the material difficult to work on.

Giving attention to such characteristics, the company plans to independently develop applications such as artificial human joints.

Polyplastic To Import/Market Liquid Crystal Polymer

Polyplastic Co. has signed a licensing contract with its U.S. parent company Ceraneeds to start marketing the liquid polymer "Vectra" (brand name).

"Vectra" is to be marketed simultaneously by Polyplastic and Ceraneeds. Polyplastic plans to import the finished goods for marketing in Japan for the time being and, after getting the marketing activities on the right track, will start domestic production.

An aromatic polyester liquid polymer, "Vectra" is made of rigid polymer which maintains straight molecular chains even in the molten state. Therefore, when the molten material flows, the polymer causes orientation toward the flow direction, exhibiting crystal characteristic even while liquid. When the polymer is cooled, the molecular orientation fixes and the fixed state is stabilized, resulting in a very high mechanical characteristic toward the direction of the orientation.

The unfilled glade of this polymer shows tensile strength of 2,100 kgf/cm² and tensile elasticity of 10×10^4 kgf/cm², values obtained by ordinary engineering plastics added with glass fiber as an enforcing material in several tens of percent. "Vectra" also features small linear expansion rate and molding shrinkage rate, low molten viscosity, and outstanding heat and chemical resistance.

Fluorine Resin Filter for Chemicals To Be Used for Semiconductor Production

Asahi Chemical Industry Co., Ltd., has developed and will shortly market a hollow yarn microfilter which is made entirely of fluorine resin. It is designed for use as a filtration membrane for high purity chemicals used in semiconductor production.

This high performance filter is intended to filtrate photosensitive resins and silicon wastes which get into high purity chemicals when a semiconductor's microcircuit pattern is made. Fluorine resin is extruded at high temperature into fine macaroni form (hollow yarn) and made sponge-like by creating uniform fine pores (0.1 μ in diameter) on the surface. About 1,000 hollow yarns are bundled together, compounded with a special fluorine resin sealing material, and put in fluorine resin modules 7 cm in diameter and 35 cm in length.

Since the filter is made entirely of fluorine resin, it has heat and chemical resistance able to process 120°C 98 percent sulfuric acid or high concentration nitric acid. Other features include circle-shaped fine pores to ensure eliminating particles of 0.1 μ in diameter, and cross-flow effect by circulating chemicals to be filtered preventing the membrane being clogged with particles.

There have been several filters where fluorine resin is used as membrane material but all exhibit problems. To make such membranes, fluorine resin powder is sintered, made into a gel and formed into a film, which is then torn to create micropores. The membrane so prepared has pores of uneven diameters, resulting in particles sticking in the pores thus deteriorating filtration efficiency.

Silicone Defoaming Agent for Water Paint, Application to Building Paints

Dow Corning has started the full-fledged marketing of a silicone deforming agent for water paints, "FS Antifoam 013B Emulsion" (brand name).

The polyether defoaming agents currently in use to eliminate foams occurring in paints have drawbacks; i.e., they need to be added in large volume and their shelf life is limited to 2-3 months.

On the other hand, this new defoaming agent having a unique emulsion structure (mutually insoluble liquids mixed and evenly dispersed) can virtually prevent foams when mixed in the paint in a proportion of 0.1-0.5 percent. It also features: 1) long-term (6 months or longer) preservation after mixing without deterioration of defoaming effect; 2) does not cause uneven finish of painting; 3) improved paint flow to make the paint membrane abrasion-resistant; and 4) excellent defoaming effect in applications, such as printer roll, where strong cutting force is imposed.

Next Generation Cyanoacrylate Adhesive With Widely Improved Shock Resistance

Cemedain Co. has developed, and is sample shipping, a next-generation cyanoacrylate adhesive (SCG) "3000DX" (brand name), with shock resistance and bending strength improved by more than five times conventional products.

Cyanoacrylate adhesives are one-solution type agents which harden very quickly at normal temperature and can adhere to a wide range of materials. Because of such characteristics they are widely used in the fields of electricity and woodcraft, and for domestic use. Conventionally available products, however, have the drawback of being weak against shock and twisting because their hardened structure is crystalline.

With the new product, reaction bridges are randomized and elastomer polymer is inserted into the base polymer in order to widen deformation allowance. As a result, T detachment strength (bending strength) compared to aluminum has been increased to 8 kg/cm^2 , 7-8 times that of conventional products; drop strength (shock strength) compared to copper to 17 kg/cm^2 , five times that of the same. The new adhesive comes in two types, depending on viscosity, the unit price for each being ¥1,000/20 g.

Cemedaïn says "3000DX" is most suitable for attaching parts of domestic appliances and light electric appliances, as well as parts for electric devices, such as automobile tail lamps. The company will also try to develop the market of precision equipment, such as cameras.

20,126/9365
CSO: 4306/3583

NEW MATERIALS

NONOXIDE-BASED CERAMICS BONDING DISCUSSED

Tokyo NIKKO MATERIALS in Japanese Apr 86 pp 52-56

[Article by Nobuyuki Tamari and Minoru Kinoshita, Osaka Industrial Technical Testing Institute]

[Text] 1. Bonding of Ceramics

Ceramics are superior, with characteristics of hardness, heat resistance, high-temperature strength, corrosion resistance, abrasion resistance, and high elasticity. They attract attention as a material with superior performance surpassing that of metal materials. On the other hand, they have the disadvantages of fragility, low reliability, and inferior processibility. As to brittleness and low reliability, with the progress in research and development (R&D) of so-called fine ceramics, superior metals are surfacing.

Techniques to manufacture ceramics with proper size, shape and function must be established for their application in structural materials or in mechanical parts. In addition, it is also necessary to develop various incidental techniques, one of which is the bonding technique.¹ This is required to overcome difficulties in manufacturing and processing large-size, complex-shaped products. There are cases where the general parts of products are not necessarily required to be of ceramics. On the contrary, it seems suitable in many cases to use ceramics with metal material, in a sense, to avoid fatal damage due to the abovementioned brittleness of ceramics.

There are various joining methods--mechanical joining such as screwing or fitting, solid-phase diffused bonding by applying heat directly to the material under pressure, and welding, which is widely applied for metal materials. The joining with a media substance between materials, i.e., so-called bonding, is believed to be an effective joining method because of being relatively easy to do resulting in airtightness and excellent strength.

Bonding technology of ceramics has been developed and made practical so far mainly in order to bond oxide ceramics to oxide ceramics or metal. On the other hand, the main material of fine ceramics is nonoxide ceramics such as silicon nitride (Si_3N_4) and silicon carbide (SiC), where the bonding technology of oxide ceramics cannot always be applied. It is necessary to establish the bonding technology of nonoxide ceramics in order to extend their application in the near future.

2. Various Bonding Methods

Bonding methods are generally classified as shown in Table 1 by the type of media substance used and the processes.

Table 1. Ceramic Bonding Method

Bonding method	Characteristics
Organic type adhesive method	Applicable to almost all materials. Inferior in strength and heat resistance.
Inorganic type adhesive method	Applicable to almost all materials. Excellent in heat resistance. Inferior in strength, airtightness, and water resistance.
Oxide soldering method High-melting point metal method Active metal method, et al.	Need processing at high temperature. Usually need adjustment of atmosphere. Excellent in airtightness and strength.

(1) Organic Type Adhesive Method

This is the simplest method used among the various combining methods. Many kinds of adhesives have been on the market and are widely used as general industrial materials. There are many types but the adhesive agent and materials to be bonded are not chemical bonds, but the Van der Waals forces bonding or hydrogen bond. Therefore, their adhesiveness is not necessarily great.

Although the characteristics of ceramics are heat resistance, that characteristic is not demonstrated in the combination by organic adhesives. Polyimide and polybenzimidazol adhesives are known to have excellent heat resistance and are used for the space shuttle; however, their heat resistance is limited to about 300-400°C. Generally, epoxy type adhesives have high tensile bonding and considerable heat resistance, so it is considered suitable for ceramics used at ordinary temperatures (Table 2).

(2) Inorganic Type Adhesive Method

Various kinds of inorganic type adhesives containing alkali silicate or phosphate as a binding agent have been sold. An adhesive composed of only binding and curing agents which dehydrate and condense cause noticeable volumetric shrinkage and cracking. Additionally, fire resisting powder, such as silica, alumina, mullite or zirconia, which have slight reactivity on a binding agent, are added to the adhesive to improve heat resistance and increase the volume ratio of the solid component. Another important role that this filler has is to adjust the coefficient of thermal expansion of

Table 2. Heat Resistance of Organic Type Adhesive²

Resistance temperature	Adhesive
80°C	Epoxy/aliphatic amine, phenol/neoprene Epoxy/polyamine, epoxy/nylon
150°C	Epoxy/aromatic amine, vinyl/phenol
205°C	Epoxy/acid anhydride, nitrile/phenol
260°C	Epoxy/phenol, epoxy/novolak
315°C	Silicon, denatured silicon
370°C	Polyimide, polybenzimidazole
480°C	Polyimide (short period)
540°C	Polybenzimidazole (short period)

the adhesive layer. The thermal expansion coefficient of nonoxide type ceramics is generally low; thus a suitable adhesive agent must be used. Moreover, in case of ceramics-metal bonding, for example, where their coefficients of thermal expansion differ greatly, the filling-bonding method which forms a thick adhesive layer is desirable, using an adhesive agent on both materials in between the coefficient level of thermal expansion (Table 3³).

(3) Oxide Soldering Method

Glass containing lead oxide is applied widely for sealing semiconductor packages, for example, because it is stable, has a comparatively low melting point and excellent electrical properties and adhesiveness. Ceramics is that which combines the glass phase inside and the oxide layer of a metal surface chemically. The PbO-ZnO-B₂O₃ system and the PbO-B₂O₃-SiO₂ system are representative types and the powder glass is applied and sealed by heating to 300 to 600°C. As the softening temperature and thermal expansion coefficient differ by composition as shown in Figure 1, the composition should be made by selecting suitable material and sealing temperature.

It is natural to raise the bonding temperature that forms a crystalline structure in bonding for high temperature use. For example, there is the glass powder of CaO-Al₂O₃-MgO-B₂O₃ system and the CaO-Al₂O₃-MgO-SiO₂ system⁵ having a heat resistance over 1,000°C. In bonding with metal, it is necessary to apply heat to the material in a neutral atmosphere or in a vacuum to prevent oxidation.

Table 3. Physical Property of Inorganic Type Adhesive (Sumiceram®)

Product	S-10A	S-14	S-16A	S-18	S-202	S-301
Main component	Silica aluminum	Silica alumina	Silica alumina	Silica	Alumina	Zirconia
Curing temperature (°C)	Over room temperature	Over 100	Over 100	Over 100	Over 300	Over 100
Resistant temperature (°C)	1,600	1,200	1,200	1,200	1,600	2,400
Compressive strength (kg/mm ²)	200	400	400	400	300	400
Thermal expansion coefficient (x 10 ⁻⁷ /°C)	30	40-80	105	80-145	80	95

High Temperature Bond Strength

Adhesive	Material to be bonded	Bond strength (kg/mm ²)				Thermal expansion coefficient (x 10 ⁻⁷ /°C)	
		100°C	300°C	500°C	700°C	Adhesive	Bonded material
S-14D	W-W	1.03	1.0	1.0	1.0	40	46
S-18C	Ti-Ti	0.81	0.52	0.38	-	80	84
S208B	Alumina-alumina	2.3	2.2	2.1	2.2	80	78
S-16A	Alumina-SUS	0.14	--	-	--	105	78 (alumina) 164 (SUS)

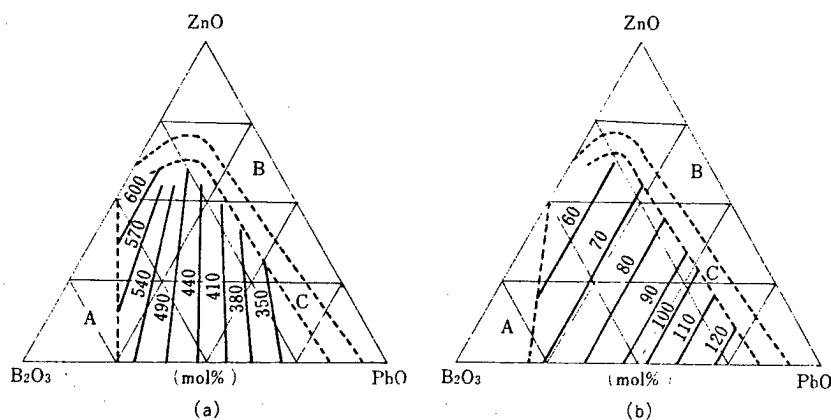

Figure 1. Physical Property of PbO-ZnO-B₂O₃-System Glass With Low Melting Point

- (a) Softening temperature (°C)
- (b) Thermal expansion coefficient (x10⁻⁷/°C)

In addition, oxide soldering which is used for the bonding of nonoxide ceramics is being studied. The bonding is performed by heating until a liquid phase is formed using $\text{Al}_2\text{O}_3\text{-SiO}_2\text{-MgO}$ and $\text{Al}_2\text{O}_3\text{-Y}_2\text{O}_3\text{-MgO}$ -system adhesives or Si_3N_4 -containing adhesives.⁶

(4) High-Melting Point Metal Method

A typical example of this method is the Mo-Mn method used for metallizing alumina. When an Mo-Mn mixture paste is applied on ceramics and heated to 1,300-1,500°C in wet hydrogen, a strong Mo layer is formed on the ceramics. Mo shows effects only on alumina which have a considerable glass phase, but requires the addition of Mn (15-20 percent) on high-purity alumina. However, metallization of higher-purity alumina is difficult (Figure 2⁷).

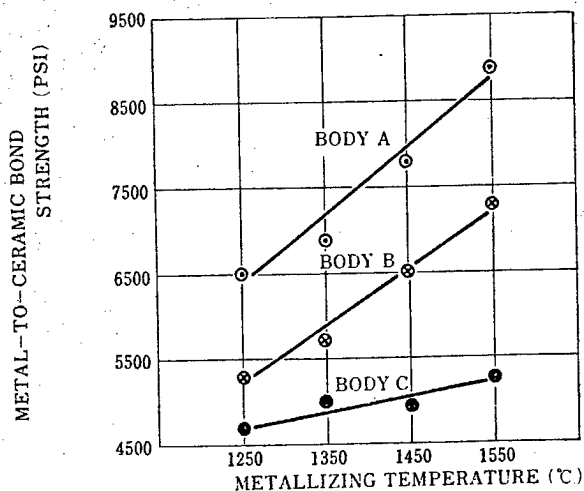

Figure 2. Alumina Bond Strength in the Mo-Mn Method⁷

(Alumina test sample Al_2O_3 : 94 percent, SiO_2 : A = 4.5 percent; B = 3.0 percent; C = 1.5 percent)

In this method, the high-melting point metal is composed of Mo-Mn as a base with its oxide or other oxides system added. It is said that Mo-Mn, W-Mn, Cr-Si, Ta-Ni, and Mo-Ti systems containing SiO_2 or CuO can be applied for metallization of nonoxide ceramics.⁸

Metallized ceramics are usually joined with metal material by soldering after plating with Ni.

(5) Active Metal Method

This method employs Ti or Zr, which easily react with ceramics, i.e., easily joined with oxide and also applied in bonding high-purity alumina, which is almost impossible to adhere with the Mo-Mn method. Ni, Cu or Ag are added to them as they have very high melting points. The alloy obtained is placed between the materials to be bonded, e.g., ceramics and metal, and is bonded

by heating and melting in a high vacuum or in a high-purity inactive atmosphere. Ti, etc., is strong in affinity with oxide and reacts and makes diffusion layers resulting in bonding of excellent strength and airtightness. As for nonoxide ceramics bonding, it is being considered to improve the composition of active metal in this method as well as in the above-mentioned Mo-Mn method⁹ (Figure 3¹⁰).

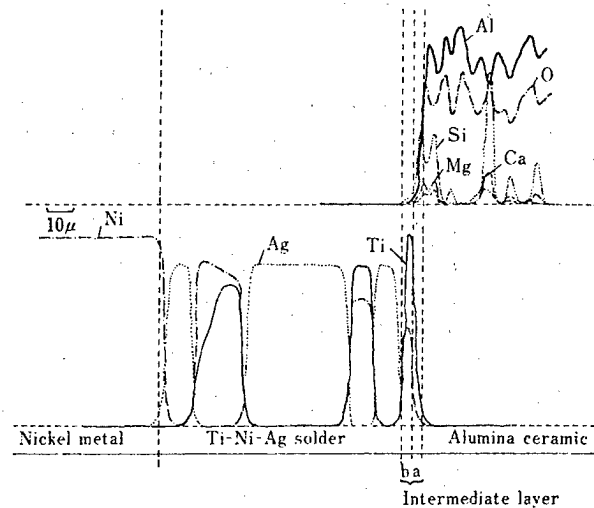

Figure 3. Element Distribution in Alumina-Nickel Bond by Ti-Ni-Ag¹⁰

(6) Bonding of Nonoxide Ceramics

In bonding a strong chemical bonding is desired rather than physical bonding; however, the slight reactivity of nonoxide ceramics to oxide makes bonding difficult. In addition, metallization and wetness become problems in bonding with metal particularly, it should be considered that the differential thermal expansion coefficients of nonoxide ceramics and metal are very different. As for the former, for example, carbon film has remarkable effects to improve Cu-Mn wax soaking¹¹ and it is necessary to consider the metallization which shows such effect on certain kinds of surface treatment or the substance media itself. The latter, a problem of difference in thermal expansion coefficients, relates not only to the bonding time, but also to the time used for bonding material. With regard to fracturing of brittle ceramics by thermal stress, multiple bonding is considered such as having the proper buffer-layer¹² or having a metal medium with an expansion coefficient¹³ similar to the main metal for adhesion.

Recently there have been newspaper reports that the bonding technique of nonoxide ceramics is being developed energetically. New trends in bonding are said to be that of an electrical bonding method where a huge electrical flow is applied to the adhesive agent.¹⁴

3. Bonding Method Development at the Osaka Industrial Technical Testing Institute

Here, the bonding method by coating adhesives on the ceramic surface or placing adhesive between ceramics and adhesives have been studied. Most of them are directed to oxide ceramics, but an introduction of bonding or metallization of nonoxide ceramics by such adhesives was presented.

(1) Using Fluoride-Containing Adhesive¹⁵

The adhesive used is based on a mixture of fluoride and kaolin or silica. This mixture in paste form is placed between silicon ceramics. After applying heat in an atmosphere up to 1,100-1,500°C, a strong adhesive is attained. To prevent oxidation, it is heated in a neutral atmosphere.

Figure 4 shows the relation between the mixture ratio of adhesive and bondage strength in bonding Cyalon. The bond strength attained is as great as 30 kg/mm² with CaF₂-kaolin-system adhesive. The bonding mechanism of this adhesion is not yet clear, but it is believed that a considerable amount of glass phase is formed by the heating, and the glass phase is well moistened by corrosion of the bonded surface produced by fluorine due to fluoride decomposition.

Rare earth oxide, etc., is added to the mixture of this system to improve heat resistance and flexibility of application. But the bonded surface layer contains considerable glass phase so the heat resistance is limited to 800°C. Airtightness and chemical resistance are good. In addition, this adhesive is effective not only on silicon nitride and silicon carbonate ceramics, but also on oxide ceramics.

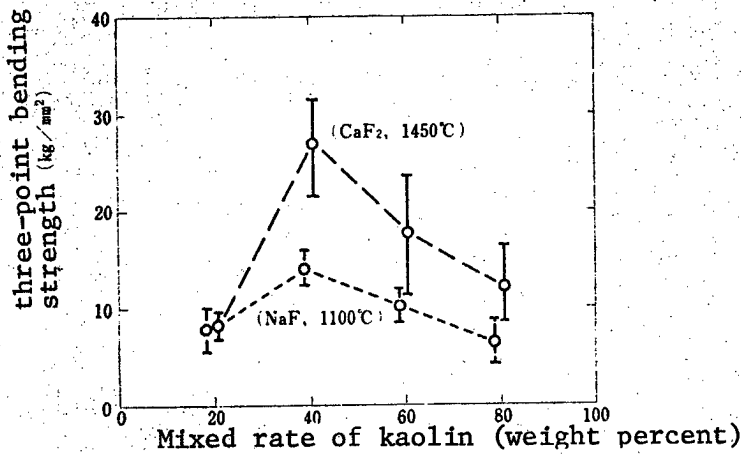

Figure 4. Bond Strength of Cyalon Sintered Under Ordinary Pressure by Fluoride Adhesive¹⁵

Heat treatment temperature is in ().

(2) Using $\text{Si}_3\text{N}_4\text{-Y}_2\text{O}_3\text{-La}_2\text{O}_3\text{-MgO}$ -System Adhesive¹⁶

So far, it is not possible to sinter silicon nitride alone other than under extra-high pressure. Generally, oxide-sintering agents such as MgO , Al_2O_3 , and Y_2O_3 are used. Accordingly, it is believed that such oxides have good affinity with silicon nitride and can be used as adhesives. It was discovered through investigation of the composition that the mixture of the $\text{Si}_3\text{N}_4\text{-Y}_2\text{O}_3\text{-La}_2\text{O}_3\text{-MgO}$ system demonstrates excellent bonding strength.

The mixture of this system is placed between silicon nitride ceramics and is heated under nitrogen atmosphere. The most suitable composition as an adhesive is: Si_3N_4 : 45 mol percent; Y_2O_3 : 27.5 mol percent; La_2O_3 : 27.5 mol percent; and MgO : 30 weight percent. By heating to $1,600^\circ\text{C}$, bonding strength becomes as great as 50 kg/mm^2 (Figure 5¹⁶).

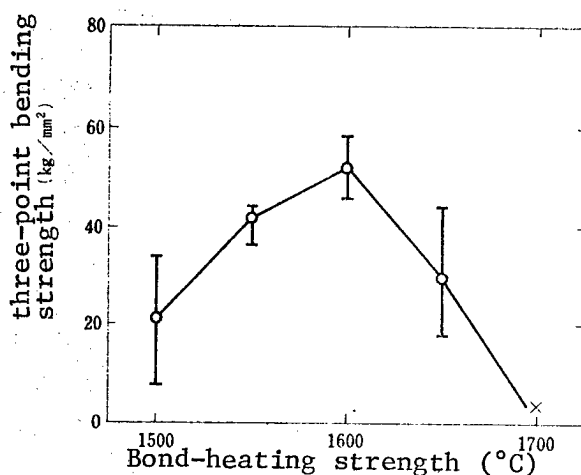

Figure 15. Bond Strength of Silicon Nitride Sintered Under Ordinary Pressure by $\text{Si}_3\text{N}_4\text{-Y}_2\text{O}_3\text{-La}_2\text{O}_3\text{-MgO}$ Adhesive¹⁶

The bonded surface of this system also contains a glass phase. The bonding layer also has a similar characteristic to silicon nitride ceramics (e.g., thermal expansion) because it contains Si_3N_4 , and therefore it is believed that a greater bonding strength was attained. The bonding strength reduces at high temperature because of the glass phase that it contains, but the bonding maintains the strength of a room temperature of about 800°C . It has good results on silicon carbonate ceramics with a certain number of changes in composition.¹⁷

(3) Metallization by Copper Compound¹⁸

Copper sulfide-kaolin mixture is applied on ceramics and heat is applied. Then, copper sulfide becomes copper oxide by decomposition and also kaolin is decomposed. Some copper components infiltrate into the oxide ceramics and form a strong-baked layer containing a small amount of metal copper produced by deoxidation of sulfur dioxide. If the baked layer containing a large amount of metal copper is made by positive deoxidation, adhesion is possible

with metal by soldering. As one of the applications of this method, it is believed possible for it to form a conductive pattern on insulating ceramics.

This method is very effective on oxide ceramics and can also be applied on nonoxide ceramics. But the bonding strength is somewhat reduced because very little copper components infiltrate into ceramics. In addition, as to joining with metal, the greatest issue is its adherence on an extensive area because of the great difference in thermal expansion coefficients (Table 4).

Table 4. Bonding Strength of Metallized Materials by Copper Compound

Ceramics	Tensile strength*
Alumina	600 kg/cm
Silicon nitride	350
Cyalon	400
Silicon carbonate	350

*When the material is bonded to copper chip by silver soldering.

4. Problems of Bonding

It is natural that strong adhesive property and heat resistance are desirable in the joining with a media layer or adhesive layer, in considering ceramics' applicability. Therefore, it is necessary for the adhesive layer to have the same physical property as that of a ceramic-ceramic bond, and the neutral property in bonding ceramics with dissimilar ceramics or metal.

In bonding nonoxide ceramics to metal, it is absolutely essential to devise an alleviating method for stress caused by difference of expansion due to temperature change between the time of bonding and use. In addition, it is necessary to establish an inspection method to guarantee reliability of bonding.

FOOTNOTES

1. Life Industry Department, Ministry of International Trade and Industry: New Material Toward the 21st Century, Fine Ceramics--Survey and Theme--Trade and Industry Investigation Committee, 1984.
2. Japan Adhesion Association, "Adhesion Handbook (Second Edition)," p 373, NIKKAN KOGYO SHIMBUN, 1971.
3. Koichi Yamada, et al., CERAMICS, Vol 11 No 9, 1976, p 785.
4. Taro Moriya, et al., "Glass Engineering Handbook," p 529, ASAKURA SHOTEN, 1963.

5. Haruo Takashio, CERAMICS ASSOCIATION BULLETIN, Vol 84 No 9, 1976, p 9.
6. Ibid., INDUSTRIAL MATERIAL, Vol 32 No 7, 1984, p 33.
7. J.R. Floyd, CERAM. BULL., Vol 42 No 2, 1963, p 65.
8. Provisional Publication No 113682/1980.
9. For example, Provisional Publication No 51774-7/1980, 106587/1982, 99184/1983, 145677/1983, etc.
10. Haruo Takashio, CERAMICS ASSOCIATION BULLETIN, Vol 84 No 12, 1976, p 594.
11. Hisanori Okamura, et al., Lecture Summary of (97th) Japan Metal Association Meeting, 1985, p 178.
12. T. Okuo, et al., HIGH TEMP. TECH., Vol 13 No 2, 1985, p 89.
13. Katsuaki Suganuma, et al., Lecture Summary of (95th) Japan Metal Association Meeting, 1984, p 261.
14. NIKKEI SANGYO SHIMBUN, 16 October and 14 November 1985.
15. Yoshihiro Ebata, et al., CERAMICS ASSOCIATION BULLETIN, Vol 90 No 12, 1982, p 715.
16. Nobuyuki Tamari, et al., Ibid., Vol 93, No 3, 1985, p 154.
17. Ibid., Preparatory Summary of the 51st Autumn Lecture Meeting of the Japan Chemical Association I, 1985, p 558.
18. Yoshihiro Ebata, et al., CERAMICS ASSOCIATION BULLETIN, Vol 92, No 5, 1984, p 294.

20,138/9365
CSO: 4306/3588

NUCLEAR DEVELOPMENT

PLUTONIUM USE IN FUTURE OF NUCLEAR POWER DISCUSSED

Tokyo PUROMETEUSU In Japanese Nov 85 pp 44-46

[Article by Shoji Nomoto, chief of Oarai Engineering Center, Power Reactor and Nuclear Fuel Development Corp.: "Age of Plutonium Use"]

[Text] It is said that petroleum will be depleted within several decades of the "oil shock," and the use of present LWR's (light-water reactors) for generating nuclear power is expected to cause a drain in inexpensive uranium resources within about 40 years.

On the other hand, it is said that concerning the use of uranium resources, the FBR (fast breeder reactor) can be used about 60 times more effectively than the LWR. A simple calculation indicates that the FBR will support human life for 2,400 years.

All the more because of this, the development of the FBR must be attained by making the best use of human intelligence. The FBR is a central item in the nuclear industrial world, and every country is vying to develop it.

Recently, the amount of plutonium for the LWR, and the concept of the HCLWR (high-converter light-water reactor) have been studied from the standpoint of effective resource use. Such plutonium can be obtained by reprocessing spent fuel. The HCLWR can have a high-conversion ratio. This article will describe the movement, significance, and background of the nuclear industrial world based on the "Age of Plutonium Use."

Present Status of Japanese FBR, ATR, and LWR

(1) Development of FBR

The development of the Japanese FBR has been carried out as a national project through the joint efforts of the government and private organizations, particularly the PNC (Power Reactor and Nuclear Fuel Development Corp.). Japan put the experimental reactor "Jo-yo," with a thermal output of 100,000 kilowatts, on-line in 1977, and presently is trying to start full-scale construction work on the prototype reactor "Monju," with an electric output of 280,000 kw. A next-generation demonstration reactor with an electric output of 1 million kw was being designed by PNC, but currently its conceptual design is being carried out by electric power companies.

In Europe, a French demonstration reactor, the "Super-Phoenix," with an electric output of 1.2 million kw went on-line at the beginning of last September. This is wonderful for the entire world.

(2) Development of ATR (Advanced Thermal Reactor)

Considering the importance of plutonium, PNC has developed the FBR and, simultaneously, has developed the heavy-water-moderated light-water-cooled ATR as an intermediate reactor in which plutonium can be used. It has already completed a prototype reactor "Fugen," with an electric output of 165,000 kw, and has operated it smoothly. Its demonstration reactor with an electric output of 600,000 kw is scheduled to be constructed with a view to developing the power source at Oma in Aomori Prefecture (see Figure 1).

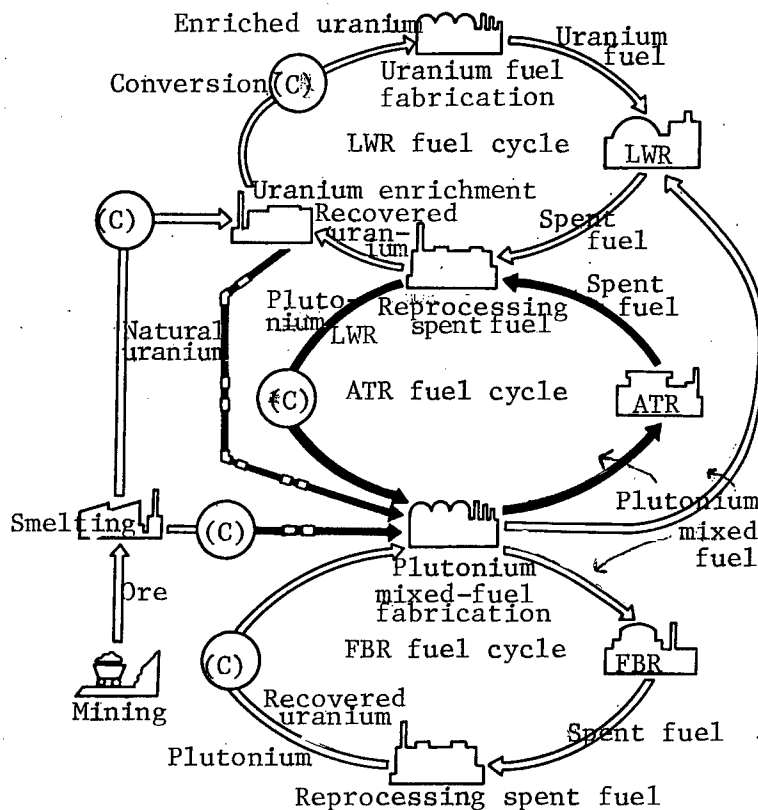

Figure 1. Concept of LWR-ATR-FBR Nuclear Fuel Cycle

(3) Amount of Plutonium Recovered From LWR

In Japan, at present, 31 commercial LWR power plants are operating smoothly, and the movement of the industrial world to the LWR (enrichment, fuel manufacturing work, reprocessing work, waste disposal, and waste storage) has grown more active annually. According to an estimate, with a second reprocessing plant having an annual processing capacity of 800 tons operating in 1995, the amount of plutonium recovered by reprocessing spent fuel will be about 50 tons in terms of fissionable plutonium in the year 2000, including

including the amount of plutonium generated from the Tokai Reprocessing Plant and the plutonium returned from overseas due to reprocessing. Similarly, the amount of such plutonium will be about 100 tons in 2010. Also, the amount of fissionable plutonium will be about 30 and 70 tons in 2000 and 2010, respectively, when the scheduled amount of plutonium used in the FBR, "Monju," the ATR, "Fugen," and demonstration reactors is deducted from the above-mentioned amounts. For this reason, the introduction of plutonium thermal reactors, HCLWR's, etc., is taken up in the nuclear fuel cycle until the FBR is put to practical use.

(4) Movement of Intermediate Reactors

Recently, the period in which it is thought the FBR would be put to practical use has lagged considerably behind general expectations, and, on the contrary, there has been a tendency to think that the LWR may be operated for some time beyond the year 2000. This is because low-price uranium has been on the market influenced by the worldwide depression and slower growth in demand for electric power, and low-price electric power can be obtained for the time being using LWR's. It is anticipated that the construction costs of present FBR's will be expensive and much time will be required for obtaining low-price electric power equal to that obtained from LWR's. There is no gainsaying the fact that there has been a slowdown for the FBR throughout the world. Originally, plutonium generated from LWR's is used in FBR's, and is completed by using ATR's. However, these LWR's themselves recycle their own plutonium, due to the delay in the development of FBR's.

Significance of Use of Plutonium

(1) Warning Against Depletion of Natural Uranium

U-235 comprises only 0.7 percent of natural uranium, with the remaining 99.3 percent being U-238. Such natural uranium enriched to about 3 percent is used in LWR's. For this reason, natural uranium close to about four times the enriched uranium necessary as a nuclear fuel must be provided. In addition, the depleted uranium (mainly U-238) obtained by enriching natural uranium has not been used in LWR's. Although LWR's have been commercialized, U-235 (a large amount of natural uranium) is used in these LWR's. Figure 2 shows the amount of uranium resources necessary when electric power is generated only by the LWR, once-through, in the free world. The price of uranium has been confirmed to be less than \$130 per kg, and it is estimated that the amount of additional resources will be 3.68 million tons. The figure shows that the demand for nuclear power generation cannot be satisfied in 2025, even with a slower growth.

(2) Increase in Resources Using FBR

As shown by the name "breeder reactor," the FBR breeds and produces more nuclear fuel as plutonium than it consumes while generating the electric power. When MOX (mixed-oxide fuel) is produced by mixing plutonium and depleted uranium, the MOX is loaded in a reactor core, and other depleted uranium is configured as a blanket around the core. Fast neutrons come into

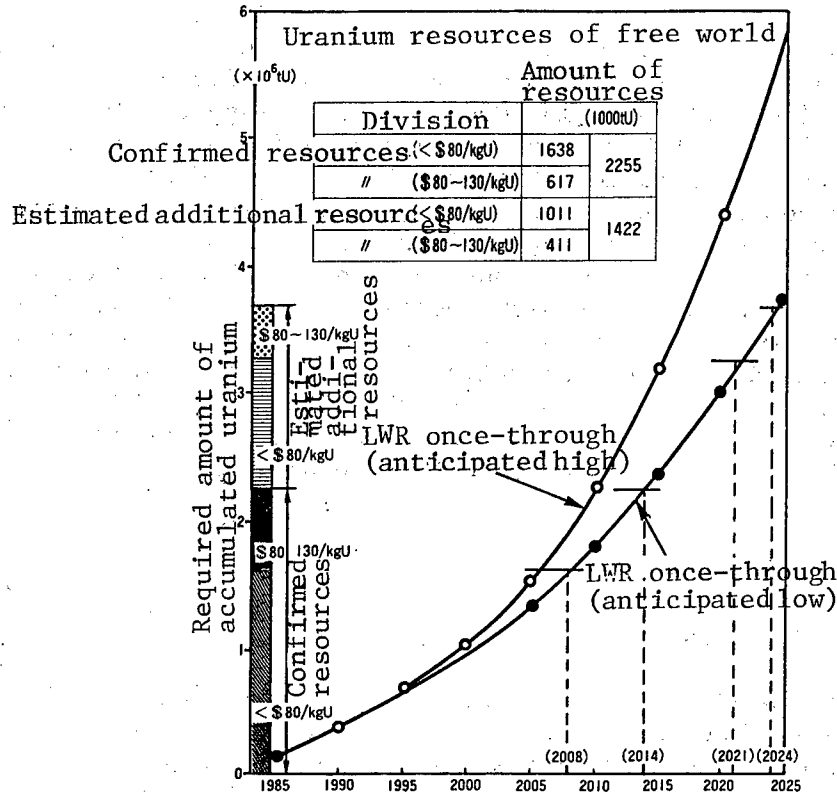

Figure 2. Required Amount of Accumulated Uranium in Hypothetical Fuel Cycle Strategy of Free World

(Extracted from the OECD-NEA (Organization for Economic Cooperation and Development-Nuclear Energy Agency) and the IAEA (International Atomic Energy Agency) in 1983 and June 1984 (partial revision))

contact with the U-238 and natural uranium is converted into plutonium. Therefore, it is possible to breed nuclear fuel.

As mentioned above, the LWR can kill two birds with one stone by simultaneously using depleted uranium and plutonium which are not efficiently burnt. It will be able to secondarily increase resources to about 60 times the conventional amount.

(3) Worldwide Trend To Develop FBR

However, there has been a worldwide trend for better plants, constructed over a considerable time, with international cooperation, rather than urgent development of FBR's at a huge cost, because of various reasons such as recession, slower growth in demand for electric power, excessive supply of low-price enriched uranium, increase in FBR construction costs, fund conditions, etc.

(4) Holding Down Increase in Plutonium Accumulated Through Reprocessing

At present, the capacity of electric facilities necessary for nuclear power generation in Japan is 23.53 million kw. It is estimated that this capacity will be 53 and 170 million kw in 2000 and 2050, respectively. The capacity in 2000 is equal to 53 LWR's each having a capacity of 1 million kw. Assuming that fissionable plutonium of about 160 kg is produced annually from an LWR after reprocessing, as previously mentioned, fissionable plutonium of about 50 tons will be accumulated in 2000. It is also estimated that a plan to use fissionable plutonium of about 30 tons will become necessary, even if the amount of fissionable plutonium necessary for the FBR and ATR is deducted from the 50 tons. Now, recycling of plutonium to LWR's and the HCLWR is being studied. The HCLWR has a higher ratio of conversion of uranium into plutonium than that of the LWR. When considering the situation in 2000 and subsequent years, the ATR must be urgently developed in order to put it to practical use, because an FBR has a capacity of 1 million kw and a heavy reactor core load, being 5 tons.

Use of Plutonium in LWR

(1) Plutonium Recycling

It has been disclosed that MITI (Ministry of International Trade and Industry) will establish a subcommittee for plutonium recycling in the Nuclear Power Committee of the Advisory Committee for Energy. This group will study the balance between demand and supply of plutonium and the amount of plutonium stored up to around 2010, and will summarize in a report its findings by around next June.

At present, MITI is scheduled to conduct demonstration tests for a PWR (pressurized water reactor) (one-third reactor core) and a BWR (boiling water reactor) (one-third reactor core) at the beginning of 1990, and is scheduled to put about 10 PWR's and BWR's to practical use around 2000. According to the latest information, France intends to load MOX to 30 percent of the reactor core of a PWR having a capacity of 900,000 kw in 1987, and intends to use such 5 and 12 PWR's by 1990 and around 2000, respectively. In order to equalize uranium enriched to 3.25 percent with plutonium, the enriched uranium must be 4.5 percent. It seems that France is considering using about 5 tons annually such plutonium. This plan is similar to that of Japan.

(2) HCLWR

Assuming that the LWR is used continuously for the time being, due to delays in practical use of the FBR, the use of uranium as well as plutonium must be considered. In addition, the short supply of uranium and a rise in price of uranium must be anticipated, and measures for them must be taken. Recently, the concept of the HCPWR (high-converter pressurized water reactor) has been advocated in order to efficiently burn much plutonium, enhance the conversion ratio to at least 0.9, and use present PWR plants by the time the FBR has been commercialized.

The HCLWR consists of a close-packed reactor core with plutonium enrichment of about 8 percent, and is structured so that it can be stored in a PWR pressure vessel. However, there are many problems, including engineering demonstrations such as on control, safety, fuel, materials, thermal removal under high temperatures and high pressure, and hydrothermal subject caused by reducing the flow passage area for coolant due to the close-packed reactor core. Particularly, there are nuclear and reactor-physical problems, because neutron spectra are in the epithermal region. These problems should be studied in the future.

As mentioned, the purposes of plutonium recycling to LWR's are to conserve natural uranium, take measures when the supply of uranium becomes insufficient, and prevent the amount of accumulated plutonium from increasing from the standpoint of nonproliferation, a philosophy enthusiastically advocated since the INFCE (International Nuclear Fuel Cycle Evaluation) was established. Other purposes include stable supply of electric power for energy security in Japan, and taking stopgap measures until the FBR is ready. Also, it would be important to positively study the HCLWR plan from the same standpoints earlier mentioned.

However, Japan should urgently solve these problems within a short term, must not be negligent in making every effort to put the promising FBR to practical use early from the standpoint of a long-term view, and must make every effort to use plutonium by the year 2000 and beyond. In addition, Japan should give further impetus to the commercialization of ATR's in which the use of plutonium has already been realized. These efforts enable Japan, poor in energy resources, to fully use quasidomestically produced energy in the form of plutonium without any dependence on imports of natural uranium.

20,143/9365

CSO: 4306/2536

NUCLEAR DEVELOPMENT

JAERI, UNIVERSITIES STRENGTHEN RESEARCH COOPERATION

Tokyo GENSHIRYOKU SANGYO SHIMBUN in Japanese 3 Jul 86 p 2

[Text] The Japan Atomic Energy Research Institute [JAERI] and 14 universities, centering around Tokyo University will this year create a new system to further strengthen research cooperation. They have already launched a "Committee to Study Japan Atomic Energy Research Institute-University Cooperative Research Projects" (chaired by Tokyo University Professor [Ryohei] Kiyose) which is conducting discussions on operational methods and concrete subjects of research, and which in the middle of July convened the first meeting of the "Back-end Chemistry Research Project Special Interest Group." The policy will be to promote research cooperation in three areas this year. These areas are actinide chemical research, basic research in improvement and heightened development of reprocessing processes, and fundamental research in evaluating the safety and heightened improvement of radioactive waste treatment processes.

Nationwide 14 Universities To Participate

Heretofore, "research cooperation" between the Japan Atomic Energy Research Institute and the various universities has been in the form of schools using Japan Atomic Energy Research Institute facilities, or on the individual level with exchanges of information, etc.

Starting this year, as one link in the chain of promoting exchanges between academic research, industry, and government, this cooperation will select research topics appropriate for organized and complex research between the universities and the Japan Atomic Energy Research Institute from among research topics in the whole field of basic nuclear power research, and will try to promote broad joint research.

Japan Atomic Energy Research Institute on its part has set up a "Committee to Study Japan Atomic Energy Research Institute -University Project Joint Research" and the universities have established the "Committee for the Promotion of Joint Research on Japan Atomic Energy Research Institute-University Projects," (chaired by Professor Kiyose) which will have as its interface the Tokyo University-Japan Atomic Energy Research Institute Nuclear Power Research Center, and proposed topics of research from each university will be coordinated by that committee.

This year, first of all, a "Back-end Chemistry Research Project Special Interest Group" has been established under the Japan Atomic Energy Research Institute's Study Committee and their 5-year plan will promote cooperation on those three research topics. Approximately ¥40 million was appropriated to the Japan Atomic Energy Research Institute for this purpose in this year's budget.

"Actinide chemical research" conducts research into the structural chemistry and solution chemistry of Neptunium, Plutonium, Americium, and other man-made super-uranium elements and plans for the expansion of the basic data base. As opposed to the present liquid method which melts spent nuclear fuel with nitric acid, "basic research in improving and furthering reprocessing processes," it will study other methods with the aim of using the results in Reprocessing Plant No 3 which will feed the private sector reprocessing plants which are scheduled to be constructed at six sites in Aomori Prefecture.

"Basic research in evaluating safety and improving the reprocessing of waste materials" conducts research in extinguishing processing and group separation of fission products, seismological shifts, etc. Kyushu University and others will participate in this.

12964

CSO: 4306/2103

SCIENCE AND TECHNOLOGY POLICY

LAW PROMOTING RESEARCH IN SPECIFIED BIOLOGICAL INDUSTRIES

Tokyo TOKI NO UGOKI in Japanese 1 Jul 86 pp 29-34

[Text] The Law Promoting Research in Specified Biological Industries went into force on 10 June and it establishes the nucleus of a structure which will promote cooperation between government and the private sector aiming for development of new technology in the agricultural, forestry and fisheries areas using biotechnology.

1. Introduction.

There have been dramatic developments in the leading-edge technologies such as biotechnology in recent years and these technological developments have had great influence on the life and economy of Japan.

The government recognizes the importance of these kinds of technological developments and has come to support actively various types of technological developments even more than in the past.

It establishes a system which will support and further the private sector's priorities for technological development in fields which are intimately related to living things, which have their own origins in living things, centering especially around agriculture, forestry and fisheries. Priorities which have heightened as progress has been made in biotechnology recently, and joining with the richness of the results of research which has been conducted at the national and public research institutes heretofore, the government has come to see the necessity of planning for an overall increase in the technological level in the nation as a whole.

Seen from that point of view, the present enactment and institution of the Law Promoting Research in Specified Biological Industries creates one link in this chain of technological development policy.

2. The aims of the Law Promoting Research in Specified Biological Industries

Technological development in the fields of agriculture, forestry and fisheries in Japan involves the functions of a variety of living things, and because this is characterized by such things as being easily influenced by natural

conditions, or as having substantial regional characteristics, and having large risks and lead-time, private sector involvement has previously been weak, and the role played by national and other governmental research facilities has been large.

However, recently in the private sector too, with the introduction and development of new technologies, starting with biotechnology, private sector involvement has become vigorous in experimental research in technology related to agriculture, forestry and fisheries where epoch-making new product types, new products, and dramatic improvements in productivity are anticipated. Private sector interest is increasing in these fields where the outlook for future technological progress is great.

While this situation of course serves to further strengthen the experimental research of the national research institutes, at the same time it is also realized that in planning for a heightened level of technology in those fields for the nation as a whole, the combination of public and private efforts and the establishment of a mechanism where the private sector can actively participate in technological development of these fields is necessary in order to contribute to an improvement in the national life and progress in the national economy. From the above perspectives the public benefit and urgent nature are great.

Together with supplying risk capital it was decided that it was necessary to establish a central organization in order to support general private research which would promote cooperation between the public and private sectors with mediation in the distribution to the private sector of national plant gene resources (The Agriculture, Forestry and Fisheries gene bank). It would also mediate cooperative research of public and private sectors in order to give the private sector the initiative for research which they could not deal with under the existing structure or which the private sector could not do by itself because the risks were great.

In considering the structure of the mechanism and the nature of the work, it was decided that a so-called "specially licensed corporation," based on a special law, was the most appropriate for something to be operated under private direction and which was founded by private initiative. Furthermore, at the time of the establishment of the new corporation, the special public corporation, the Institute of Agricultural Machinery, was abolished and its duties are to be continued by the new corporation.

The Institute of Agricultural Machinery was established in 1962 based on the Law Promoting Farm Mechanization, and it conducted work in the formal testing of agricultural implements and conducted experimental research related to the improvement of farm machinery and the like. It is not necessary to state the important role this Institute played in the promotion of Japanese agriculture and as the importance of such work will not change in agricultural policy in the future, it was decided to have the new corporation continue these activities in order to promote farm mechanization.

3. Overview of the Law Promoting Research in Specified Biological Industries

The main points of the Law Promoting Research in Specified Biological Industries which was passed in the 104th regular session of the Diet (14 May) promulgated and which went into effect on 10 June are as follows.

(1) Purpose:

A. The organization for promoting research in specified biological industries (hereafter called the organization) by conducting work related to the promotion of private sector experimental research in technologies in specified biological industries (the duty of promoting research in the private sector, see chart 2) and fostering improvement in technology in specified biological industries, aims to contribute to the improvement of the life of the Japanese people and to the healthy development of the Japanese economy.

B. The organization, besides that stipulated in the preceding paragraph, by designating the aspect of the Law Promoting Farm Mechanization, has the purpose of conducting operations (the duty of promoting farm mechanization) in experimental research related to the improvement of agricultural machinery which will contribute to the promotion of farm mechanization.

(2) Definition

In the law "technology related to specified biological industries" is that which satisfies the following conditions.

A. That it is technology which relates to activities (industries) which utilize and acquire the results of manifestations of functions of living things, or which utilizes or increases support for the function of living things.

B. Among those things to which "A" above applies are: a. agriculture, forestry and fisheries industries, b. food and beverage manufacturing industries, c. tobacco manufacturing industry, d. that it be technology (with the exception of basic technology defined in article 2 of the Law for Harmonization of Basic Technology Research) related to activities which belong to industrial categories designated by government regulation as industrial categories where planning for an increased technological level is especially necessary or appropriate and which considers the nature of technology related to the activities of these other industries.

C. Among those to which "B" above applies are that they be technologies administered by the government ministry with jurisdiction for such activities.

D. Furthermore, in undertaking such development that they be technologies where experimental research is intimately related to the function or to the characteristics of the results of manifestations of living things.

(3) Capital

Capital for the organization will be composed at the outset of amounts which will be made up of funds continued from those allocated from the Farm Machinery Research Institute and from funds provided by the government and others. When necessary funding may be increased with the permission of the main ministers involved (minister of agriculture, minister of finance, and ministers with jurisdiction over those industrial categories designated by government order).

(4) Establishment

In establishing such structures promoters will be groups of 15 or more who have scholarly experience with technology in specified biological industries and they will conduct the search for funding, and will obtain the permission of the minister of agriculture and the minister of finance.

(5) Officials, etc.

A. As officials (full time officials) the organization will have one chief director, one deputy director, five regular directors, and one inspector.

B. The organization will have conference committees as a means of studying important items concerning the operation of the organization.

(6) Work

The organization will undertake the following operations in order to reach each goal.

A. The lending or supplying of necessary funding for private sector experimental research related to technology in specified biological industries.

B. Facilitation of the conducting of joint research by those outside of government with the national research institutions in experimental research in specified biological industries.

C. Facilitating, for those who conduct experimental research in technology related to specified biological industries, the reception of distribution of the whole bodies of living things or parts thereof (so-called genetic resources) as materials for such experimental research from national resources.

D. The invitation to researchers from abroad to work on technology related to specified biological industries.

E. To conduct such work as was specified under the Law Promoting Farm Mechanization.

F. Other.

(7) Finance and accounting.

A. The organization will distinguish in its management operations the work of promoting private sector research and the work of promoting farm mechanization and will establish and regulate separate accounts for each.

B. In addition they will prepare regulations relating to the disposition of profits and losses, financial statements, budget approvals, etc.

(8) Abolition of the Farm Machinery Research Institute, etc.

A. The Farm Machinery Research Institute will be abolished at the time of the creation of the organization, and all of its duties and authority shall be continued by the organization.

B. Together with having the organization implement the work of promoting farm mechanization which heretofore was conducted by the Farm Machinery Research Institute, a modification of the Law Promoting Farm Mechanization will occur.

C. Together with A, and B above a mechanization will also be created as needed for taxation.

4. Conclusion

Hereafter, with a target of this autumn, after the processes of obtaining the appropriate ministerial approvals, collecting funds, and holding originators' meetings, it is expected that the organization supporting technological research in specified biological industries will be established, and at present various preparations and studies are being made for that eventuality. It is hoped the new organization will contribute greatly to the promotion of private sector experimental research in technology in biological industries, starting with agriculture, forestry, and fisheries. (Ministry of Agriculture, Forestry, and Fisheries)

Chart 1. Positioning for fostering private sector technological research

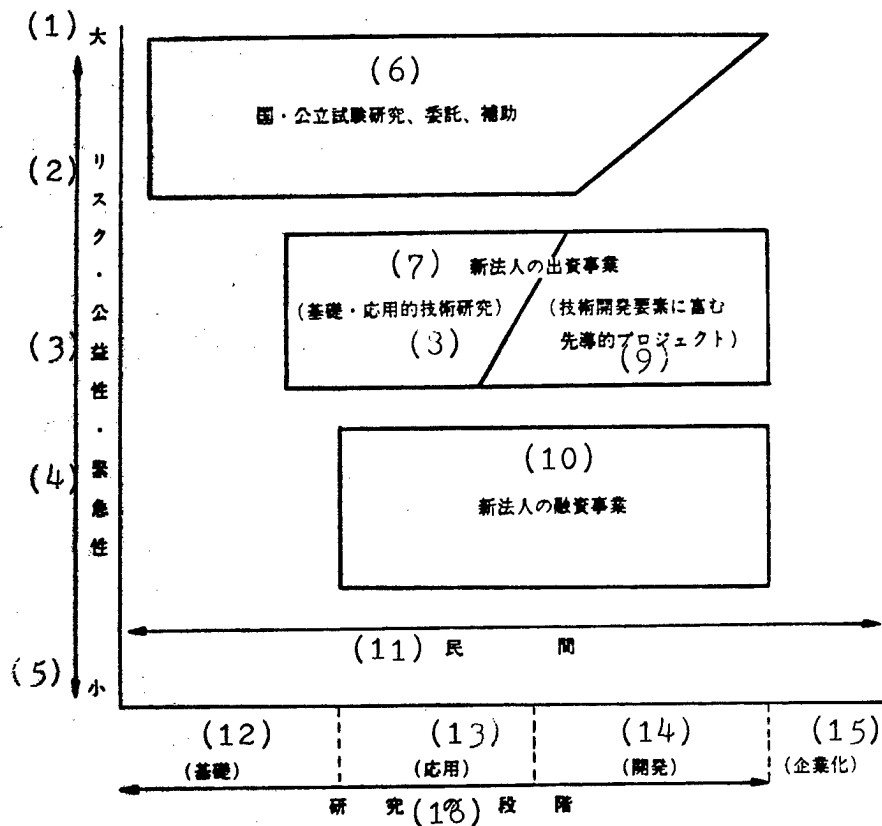

Key:

1. More
2. Risk
3. Profitability
4. urgency
5. Less
6. National and public research, charge, support
7. New Corporation's work in supplying capital
8. Basic and applied technological research
9. Vanguard research projects which are rich in essential elements of technological development
10. New corporation's work in financing
11. Private sector
12. Basic
13. Applied
14. Developmental
15. Industrialization
16. Stage of research

Chart 2. Plan for Work of Promoting Private Sector Research

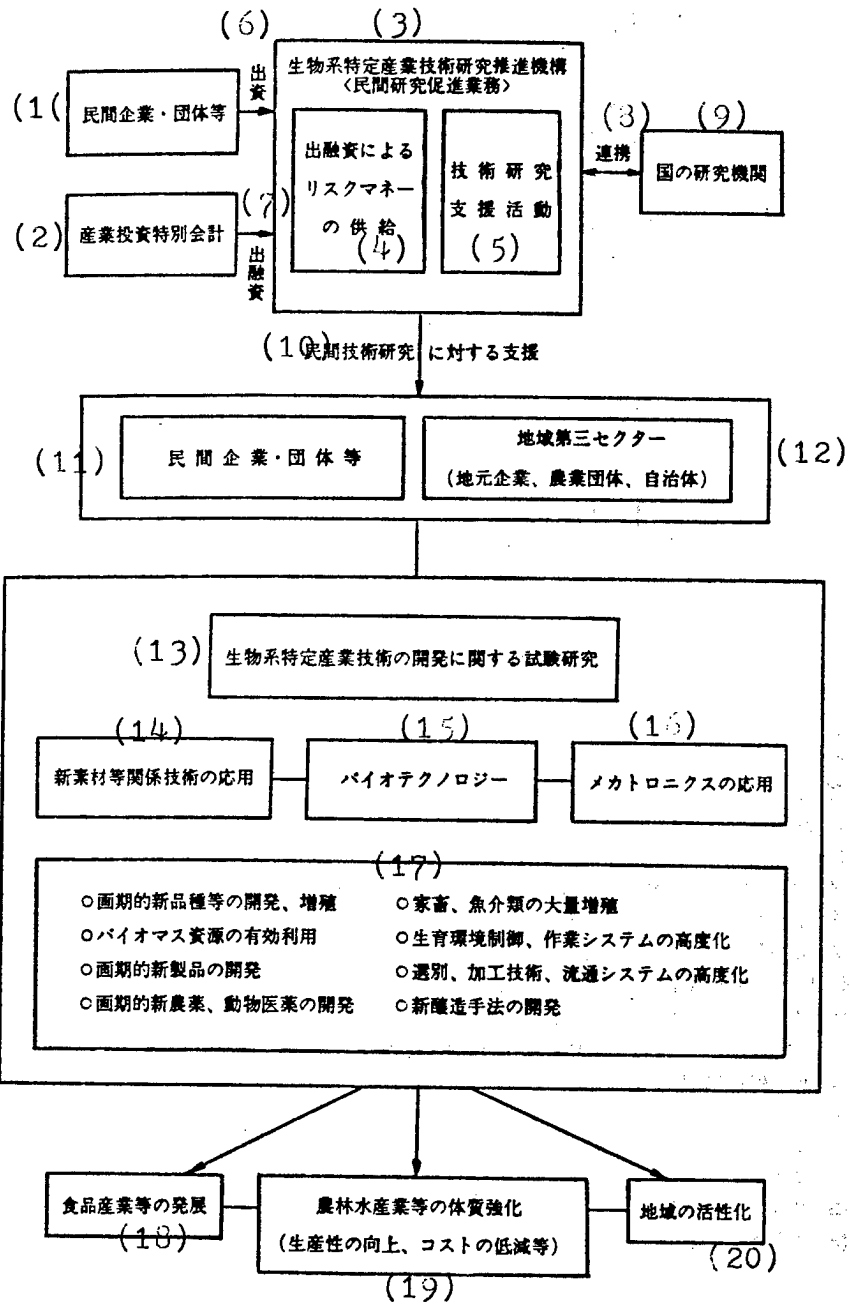

[key on following page]

Key:

1. Private Industry, groups
2. Industrial investment special account
3. Organization promoting technological research in specified biological industries (work of promoting private sector research)
4. Risk funds supplied by financing
5. Technology research support activities
6. Supply of capital
7. Supply of financing
8. Cooperation
9. National research institutions
10. Support for private sector technological research
11. Private Industry, organizations
12. Regional 3 sectors (Local Industry, agricultural organizations, local government)
13. Experimental research related to the development of technology in specified biological industries
14. Application of technology related to new materials
15. Biotechnology
16. Mechatronics applications
17. Development and expansion of epoch-making new product categories, effective use of biomass resources, development of epoch-making new products, development of epoch-making fertilizers and veterinary pharmaceuticals, increasing quantity of seafood and livestock, improving control of environment for birth and breeding, and improvement in working systems, improvements in selection, processing technology and distribution system, development of new brewing methods
18. Development of foodstuffs industry
19. Strengthening the constitution of the agriculture, forestry and fisheries industries, etc. (improving productivity and cost efficiency)
20. Regional activation

12964

CSO:4306/3085

SENSOR TECHNOLOGY

RESEARCH ON OPTICAL IC SENSOR REPORTED

Tokyo KINO ZAIRYO in Japanese Feb 86 pp 19-26

[Article by Masamitsu Haruna, assistant, Electronics Course, Engineering Department, Osaka University: "Research Trend on Optical IC Sensor"]

[Text] Optical integrated circuit (optical IC) is being given attention as a future technology in the field of optical communication and optical signal processing. In this paper, focusing on the application of optical IC to sensors, the recent research trend is introduced. Optical IC sensors can be roughly divided into waveguide-type sensor devices using film waveguide as sensor, and integration of fiber sensor signal processing optical systems. In this article, the concrete research results of both are mentioned.

1. Application of Optical IC to Sensors

Optical fiber is highly accessible to objects because of its high flexibility and furthermore, it has characteristics of being noninductive and highly capable of insulating. By making the most of these characteristics, the development of optical fiber sensors has been actively conducted in recent years and some of them are now being put to practical use. The optical systems necessary for these fiber sensors are composed by combining fiber devices and microoptical parts. Consequently, connection and alignment between individual parts, including fibers, become the important factors in determining the characteristics of the sensors. In contrast to this, by manufacturing individual parts by using film waveguide technology and integrating these on a substrate, measurement at a higher accuracy in a further miniaturized and stabilized device can be expected. Furthermore, it is possible to sense such physical quantities as temperature and pressure by film waveguide itself, and in this case, it becomes possible to integrate all parts, including the sensor unit. By using optical IC technology, vibration resistant sensor optical systems can be realized. This probably will be directly linked with miniaturization and price reduction of sensor systems in the future.

Research on optical IC has been conducted for more than 10 years, during which a variety of waveguide-type devices, including the optical modulator, have already been realized. Thus, it is now drawing attention as a future technology in the field of optical communication and optical signal processing.¹

In comparison, research on optical IC sensor was started only a few years ago, and has not yet been put to practical use. Present research is roughly divided between waveguide-type sensor devices using film waveguide as sensor, and integration of signal processing optical systems required for fiber sensors. Materials and devices used for optical IC sensors and the manufacture of IC are mentioned below.

2. Substrate Materials of Optical IC Sensors and Waveguide Manufacturing Technology

LiNbO_3 exhibits great electrooptic effect, and by applying thermal diffusion of Ti to it, a waveguide of about 1 dB/cm in propagation loss can be easily manufactured. Such being the case, this material is most frequently used as the substrate material of optical IC. This crystal also has a refractive index temperature coefficient of $\sim 5 \times 10^{-5}/^\circ\text{C}$ and exhibits the photoelastic effect, and can thus be used as the material for waveguide-type sensor devices. The principal material of optical IC sensors is LiNbO_3 , but the ion-exchanged glass waveguide is often used also.

2.1. LiNbO_3 Waveguide

The general substrate material is Z-plate crystal whose optical axis is perpendicular to the surface at the SAW grade. By patterning Ti film in the shape of waveguide by the lift-off method and then putting it to thermal diffusion of Ti at $1,000^\circ\text{C}$ for several hours in water-vapor infused inert gas atmosphere and heat treatment for about an hour in oxygen atmosphere, the waveguide can be acquired. At the wavelength $0.63 \mu\text{m}$, the surface refraction change due to Ti diffusion is $\sim 10^{-2}$, and the diffusion depth is $\sim 2 \mu\text{m}$; therefore, for making it conduct single-mode propagation, the waveguide width is 3 - $4 \mu\text{m}$. By this method, a desired low-loss waveguide including fork, bend, directional coupler, etc., can be manufactured. For composing optical modulator/switch, etc., it is enough to load aluminum electrode through the aid of an SiO_2 buffer layer after the waveguide is manufactured. Here, the Z-plate LiNbO_3 has the advantage that the lateral diffusion of Ti is small and the maximum electrooptic coefficient r_{33} can be used. However, the light damage in the range from visible light to near infrared light of $\sim 1 \mu\text{m}$ is a problem. To solve this problem, measures are taken to square the propagation direction of guided beam with the optical axis or to use a semiconductor laser of $1.3 \mu\text{m}$ band or $1.5 \mu\text{m}$ band in the light source.

2.2. Ion-Exchanged Glass Waveguide

With soda glass containing Na^+ ion as the substrate, Na^+ ion is substituted with K^+ ion in part of the glass surface. That part then increases its refractive index by 10^{-3} order and turns into a waveguide. Aluminum film is evaporated onto the soda glass surface, and this is windowed in the shape of waveguide by photolithography. The glass is then soaked in KNO_3 solution at 370°C for about an hour. By this method, a low-loss waveguide with a propagation loss of less than 1 dB can be manufactured. In the case of a completely passive optical system, such as an optical modulator that contains no functional device, optical IC can be composed by this glass waveguide.

3. Waveguide-Type Sensor Devices

In this section, devices of the type to use film waveguide as sensor are discussed. These are divided into the type to use the refractive index change of waveguide material due to temperature or pressure, and the type to improve sensor sensitivity by cladding a proper film material on the waveguide surface.

3.1. Temperature Sensor

By using Ti-diffused LiNbO₃ waveguide, a temperature sensor as shown in Figure 1 can be made.² This is substantially a Mach-Zehnder interferometer having two arms of different lengths. The standard of measurement resolution is the ambient temperature change required for giving the phase difference of π , that is, the half-wavelength temperature T_{π} , which is determined by the difference of length ΔL between the two arms. In LiNbO₃, $T_{\pi} = 4.2/\Delta L$ ($^{\circ}\text{C}$), where the unit of ΔL is mm. In the type shown in Figure 1, it is difficult to take a large optical-path difference, and ΔL is 0.12 mm at most, and in this case, T_{π} is 35°C . Furthermore, with only one interferometer, the dynamic range cannot be made wide. Thus, by integrating three interferometers differing in ΔL on one and the same substrate, temperature measurement in the range of greater than 700°C becomes possible.

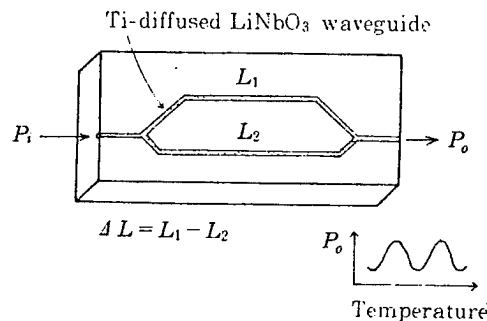

Figure 1. LiNbO₃ Waveguide-Type Temperature Sensor²

In contrast, when composing an interferometer by using π -arced waveguide as shown in Figure 2, it is easily possible to acquire an optical-path difference of more than 10 mm. The experiment was conducted by using a single-mode proton-exchanged LiNbO₃ waveguide of $3\ \mu\text{m}$ in width, with a result of $T_{\pi} = 0.3^{\circ}\text{C}$ at $\Delta L = 30\ \text{mm}$.³ Also, by putting a reflecting mirror in the middle of the Ti-diffused waveguide, a waveguide Michelson interferometer with a large optical-path difference was made; this is now put to use as a high-sensitivity temperature sensor.⁴

3.2. Pressure Sensor

By using the photoelastic effect of Ti-diffused waveguide, pressure can be sensed. Shown in Figure 3 is a pressure sensor so designed that the guided beam phase changes due to pressure applied to one arm for output of

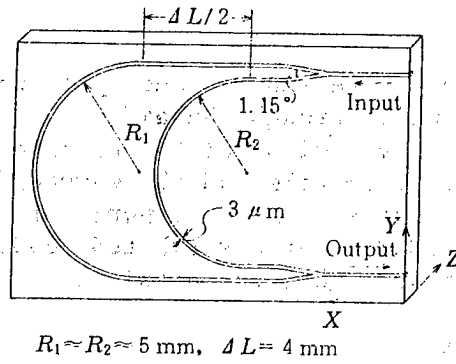

Figure 2. High-Sensitivity Temperature Sensor Being Proton-Exchanged LiNbO_3 π -Arced Waveguide³

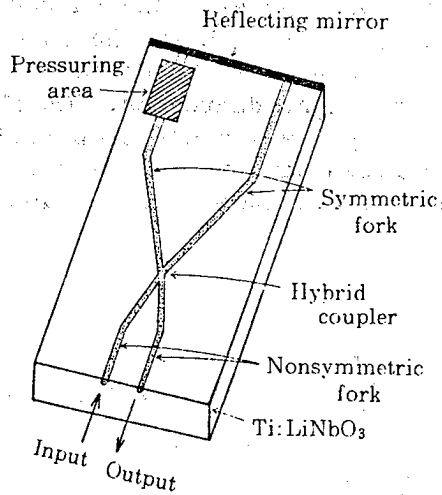

Figure 3. Pressure Sensor Using LiNbO_3 X-Forked Waveguide⁵

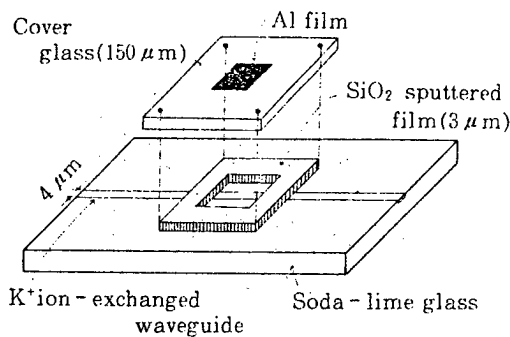

Figure 4. Metal-Clad Waveguide-Type Pressure Sensor⁶

nonsymmetric X-forked waveguide. This is detected as the change in the strength of output light.⁵

Figure 4 shows a metal-clad pressure sensor made by loading aluminum film on the ion-exchanged glass waveguide through the aid of a proper buffer layer.⁶ Pressure from above makes the cover glass or the stainless film bend, and thus the space between the aluminum film and the waveguide decreases and the propagation loss of light increases. In the experiment, water was used as the buffer layer, and under 300 Torr of distributed load, about 80 percent change in the strength of output light, was acquired.

3.3 Humidity and Gas Sensors

By utilizing the phenomenon that the thickness, the refractive index, or the light absorption coefficient of waveguide changes due to ambient humidity or gas density, sensors can be made. Figure 5 shows a humidity sensor made by spin-coating gel-state $\text{SiO}_2\text{-TiO}_2$ on a pyrex glass substrate and building therein a relief-shaped grating coupler.⁷ When the waveguide absorbs H_2O , its thickness changes, the incident angle of light deviates from the optimum value, and the strength of output light decreases. On the other hand, Figure 6 shows a hydrogen gas sensor made by loading electrochromic materials WO_3 and Pd in layers on the ion-exchanged glass waveguide.⁸ The clad layers dissociate and adsorb hydrogen gas in the surroundings, and the absorbance to the guided beam changes.

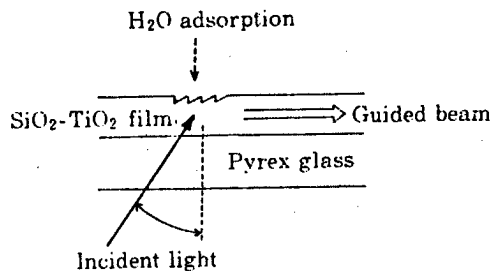

Figure 5. Humidity Sensor Using $\text{SiO}_2\text{-TiO}_2$ Film⁷

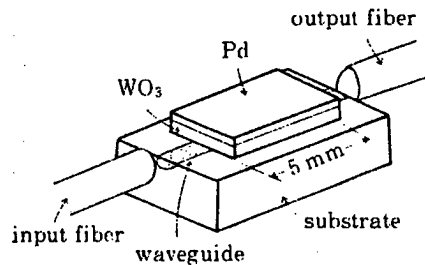

Figure 6. Hydrogen Gas Sensor⁸

3.4. Displacement and Electromagnetic Field Sensors

Experimentation of the very small displacement sensor is conducted by measuring periodic changes of the strength of output light by placing a diaphragm such as PZT near the outgoing end of one arm of the waveguide-type Michelson interferometer.⁹

Also, the high-speed LiNbO₃ waveguide-type modulator that can be driven by low voltage can be used as an electromagnetic field sensor. As an example of this, in an interferometer modulator of the structure similar to that in Figure 1, the optical bias is set at $\Delta\phi = \pi/2$ of good linearity, and the characteristics of using this as an electromagnetic field sensor are being studied.¹⁰

4. Key Components of Optical IC for Fiber Sensors

In parallel with the waveguide-type sensor devices mentioned in the previous paragraph, integration of signal processing optical systems necessary for fiber sensors is another important research theme on optical IC sensors. For the high-sensitivity sensor optical systems using single-mode optical fibers, distribution of light power and wave coupling and interference are of primary necessity, and in the null method, the phase shifter for phase compensation is required.

Furthermore, in interference optical systems, generally such polarization controlling devices as a polarizer and a polarized beam splitter are incorporated. Also, for the heterodyne detection optical system, a typical sensor optical system, a proper frequency shifter is necessary. The waveguide-type devices having these functions are introduced below.

4.1. Distribution of Light Power, Wave Coupling, and Interference

The most fundamental waveguide-type device that meets this requirement is the single-mode Y-forked waveguide. Its insertion loss as a power distribution device is about 1 dB; when it is used for wave coupling and interference, its insertion loss is substantially more than 3 dB. Furthermore, the directional coupler of the coupler length being one-half the complete coupled length L_c (this is called 3-dB coupler), it can also be used as a power distribution or a wave coupling and interference device.¹

4.2. Phase Shifter

For a phase shifter, the LiNbO₃ phase modulator is used. However, when driving this by direct current or in the low-frequency domain, there arises the troublesome phenomenon that output light strength drifts as time goes by. This so-called DC drift is conspicuous in visible light and becomes an obstacle to putting the LiNbO₃ waveguide-type devices to practical use. In a comparison, if the response speed is allowed to be less than several kHz, a thermo-optical (TO) changer that positively uses the refractive index change due to temperature can also be used as the phase shifter.¹¹

4.3. Polarization-Controlling Devices

4.3.1. Polarizer

By directly cladding a metal, such as aluminum, on the waveguide, a TE-permeation TM-absorption polarizer can be easily obtained. Also, by loading calcite, an anisotropic crystal, on the glass waveguide, a low insertion-loss polarizer can be made.¹

4.3.2. Polarized Beam Splitter

In sensor optical systems using the polarization modes of both TE and TM by using polarization-conserved optical fiber, a polarized beam splitter is important in raising the utilization efficiency of light. The waveguide-type device having this function is the TE/TM mode splitter. In connection with this, devices using the LiNbO₃ Y-forked waveguide and the directional coupler are being suggested,^{12,13} but what is best suited for integration is the type using the two-mode waveguide coupler.¹⁴

4.3.3. Wave Plate

As a device to control the polarization plane of light, such as the $\lambda/2$ plate or the $\lambda/4$ plate, there is the TE/TM mode converter. This is made, as shown in Figure 7, by using X-cut Y-propagation LiNbO₃.¹⁵ Here, the cycle of electrooptic grating necessary for taking phase-matching of the two modes is $\sim 7 \mu\text{m}$ at wavelength $0.63 \mu\text{m}$. This mode converter shows a very sharp wavelength dependency as a matter of principle, but when selecting a small-birefringence material for the substrate, the manufacturing accuracy of the device along with wavelength dependency can be eased.

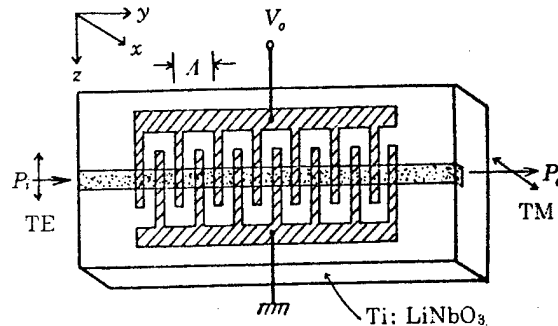

Figure 7. TE/TM Mode Converter Using X-Cut Y-Propagation LiNbO₃¹⁵

4.4. Frequency Shifter

In the heterodyne optical system, the single sideband generation device (SSB modulator) that shifts light frequency by a certain amount is required. Figure 8 shows the serrodyne-system waveguide-type SSB modulator.¹⁶ The sawtooth wave voltage is impressed on it. Its performance is determined by

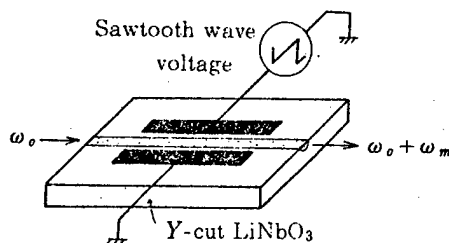

Figure 8. Serrodyne-Type SSB Modulator¹⁶

the impressed voltage waveform and is Δf less than several MHz. If a further larger frequency shift is necessary, an SSB modulator wherein the amplitude modulator and the phase shifter are integrated is suitable.^{17,18}

4.5. Connection of Optical Fiber and Waveguide

To realize optical IC for fiber sensors, position alignment and permanent bonding of single-mode fiber and single-mode waveguide are important problems. Thus far, position alignment of the two has been conducted by using the Si-V groove. This method is particularly effective in simultaneously connecting multiple fibers and waveguides; however, when conducting permanent bonding, there is concern that with the effect of resin, fibers get slightly out of position in the V groove. On the other hand, when the waveguide end surface to which the fiber is to be connected is loaded with the same block as the waveguide material, this problem is solved, and coupling efficiency of more than 80 percent can be acquired relatively easily.¹⁹

5. Examples of Optical IC for Fiber Sensors

No example of integrating all necessary components for a fiber sensor optical system on one substrate has yet been reported. However, the research situation on optical IC for fiber gyro and fiber laser Doppler velocimeter (LDV) is mentioned below.

5.1. Optical IC for Fiber Gyro

Of a variety of fiber sensors, research on the fiber gyro using the Sagnac effect is being conducted most actively.²⁰ With regard to the making by IC of this phase modulation type fiber gyro optical system, the simplest one is that in which only the LiNbO_3 phase modulator is incorporated in the optical system.²¹ Figure 9 shows an example of further integrating in it the 3-dB coupler and the polarizer.²² Also, studies are being conducted on the making by optical IC of the frequency modulation type fiber gyro wherein the dynamic range can be taken large. Shown in Figure 10 is an example of its experimentation. On the LiNbO_3 substrate, two SAW transducers are arranged and driven by RF power called f_1 and f_2 , respectively. The frequency shift of light caused by this is equal to $\Delta f = f_1 - f_2$. Experimentation is being conducted by integrating this SSB modulator and the aspheric geodesic lens, and connecting the single-mode fiber to the input and output ends of the waveguide.²³

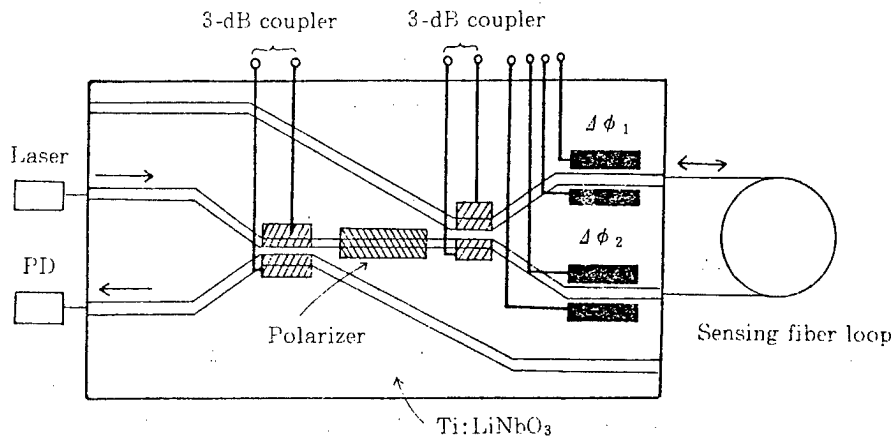

Figure 9. Conceptual Diagram of Optical IC for Fiber Gyro²²

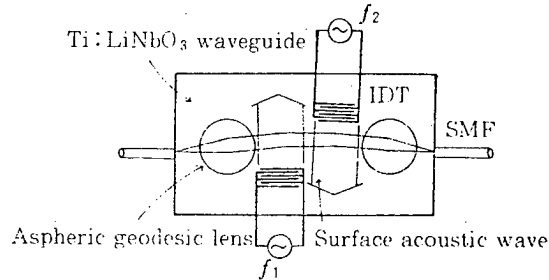

Figure 10. Making by Optical IC of Frequency Modulation Type Fiber Gyro²³

5.2. Optical IC for Fiber LDV

Fiber LDV is a system developed for hemotachometry.²⁴ The optical system was made by using individual optical parts, but when conducting a more accurate hemotachometry with the polarization-conserved optical fiber as the probe, the making by IC of the optical system becomes necessary. Figure 11 shows an optical IC wherein a serrodyne-type SSB modulator is incorporated, and its experimental system.²⁵ The substrate is Z-propagation X-cut LiNbO₃, and the single-mode fiber is connected to the outgoing end of the waveguide by permanent bonding. In this experiment, the Doppler shift signal light was detected at the S/N ratio of more than 20 dB.

6. Future Trend of Optical IC Sensors

In the foregoing, the research trend on optical IC sensors has been discussed by dividing them into waveguide-type sensor devices and optical IC for fiber sensors. From the standpoint of practical use, the latter being directly linked with fiber sensors is more interesting. In current fiber sensor optical systems, studies are being conducted on the so-called full optical fiber system formation to compose all devices, such as 3-dB coupler, polarizer, and modulator, by fibers. However, when considering yield at the time of

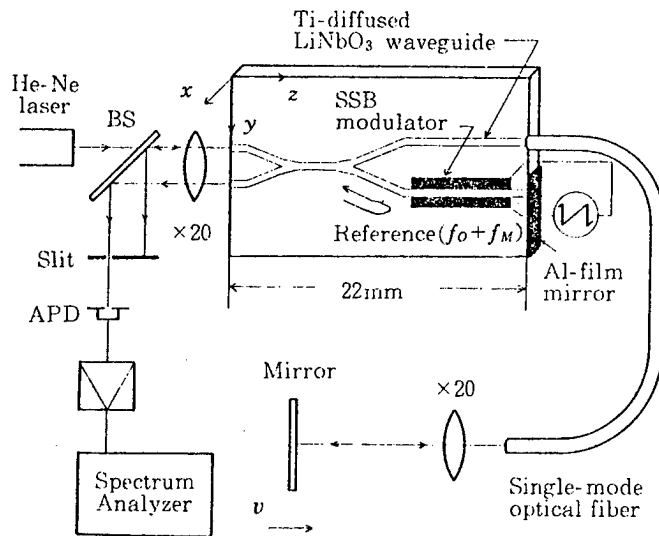

Figure 11. SSB Modulator Incorporated Optical IC for Fiber LDV and Its Experimental System^{2,5}

manufacture of individual devices, their mutual connection technology, and the miniaturization, stabilization, and price reduction of optical systems, it is considered necessary to integrate sensor optical systems on one substrate. Furthermore, when trying to integrate all components necessary for sensing, the total length of optical IC reaches more than 50 mm, and development of large-size waveguide patterning technology becomes a new problem.

On the other hand, since former waveguide-type sensor devices are inferior to the fiber sensors regarding accessibility to the objects to be measured, the range of its use may possibly be limited. Still, that the sensor unit and the optical system can be integrated on one substrate is attractive.

In any case, it is presumed that in the optical IC application field, this application to sensors is nearest to the practical use of optical IC. Optical IC researchers are aiming at the practical use of optical IC with this optical IC sensor as a breakthrough.

FOOTNOTES

1. Nishihara, Haruna, and Sahara, "Optical Integrated Circuit," OHMSHA, February 1985.
2. L.M. Johnson, F.J. Leonberger, and G.W. Pratt, Jr., APPL. PHYS. LETT., Vol 41 No 2, 1982, pp 134-136.
3. M. Haruna, H. Nakajima, and H. Nishihara, APPL. OPT., Vol 24, August 1985, p 15.

4. Enokihara, Izutsu, and Sueta, Optics and Radio Department, 1984 meeting of Institute of Electronics and Communication Engineers of Japan, 343.
5. M. Izutsu, A. Enokihara, N. Mekada, and T. Sueta, European Conf. Integrated Optics, TECH. DIG., pp 144-147, Firenze, 1983.
6. Maeda, Haruna, and Nishiara, Optics and Radio Department, 1984 meeting of Institute of Electronics and Communication Engineers of Japan, 345.
7. K. Tiefenthaler and W. Lukoz, OPT. LETT., Vol 10 No 4, 1984, pp 137-139.
8. Nishizawa, Sudo, Maeda, and Yamazaki, 1985 spring meeting of Applied Physics Society, 30a N3.
9. M. Izutsu, A. Enokihara, and T. Sueta, ELECTRON. LETT., Vol 18, 1982, pp 867-868.
10. C.H. Bulmer, R.P. Moeller, and W.K. Burns, European Conf. Integrated Optics, TECH DIG., Firenze, 1983, pp 140-143.
11. M. Haruna and J. Koyama, IEE Proc. Part H, 13, Microwave, Optics, Antennas, Vol 5, 1984, pp 322-324.
12. M. Masuda and G.L. Yip, APPL. PHYS. LETT., Vol 37 No 1, 1980, pp 20-22.
13. O. Mikami, Ibid., Vol 36 No 7, 1980, pp 491-492.
14. D. Yap, L.M. Johnson, and G.W. Pratt, Jr., Ibid., Vol 44 No 6, 1984, pp 583-585.
15. R.C. Alferness and L.L. Buhl, OPT. LETT., Vol 5 No 11, 1980, pp 473-475.
16. K.K. Wang, R.M. de LaRue, and S. Wright, Ibid., Vol 7 No 11, 1982, pp 546-548.
17. M. Izutsu, S. Shikama, and T. Sueta, IEEE J. Quantum Electron. OE-17, No 11, 1981, pp 2225-2227.
18. F. Heismann and R. Ulrich, Ibid., OE-18, No 4, 1982, pp 767-771.
19. K.H. Cameron, ELECTRON. LETT., Vol 20 No 23, 1984, pp 974-976.
20. Noda, O plus E, Vol 67, June 1985, pp 64-74.
21. G. Domann, European Conf. Integrated Optics, TECH. DIG., Firenze, 1983, pp 156-158.
22. H.J. Arditty, et al., Int. Conf. Optical Fiber Sensors Proc., London, 1983, pp 147-150.

23. H. Ohgi, M. Kondoh, and M. Shimizu, Int. Conf. Optical Fiber Sensors Proc., Stuttgart, 1984, pp 297-300.
24. H. Nishihara, J. Koyama, N. Hoki, F. Kajiya, M. Hironaga, and M. Kano, APPL. OPT., Vol 21 No 10, 1982, pp 1785-1790.
25. Toda, Haruna, and Nishihara, Optical Waveguide, Autumn 1985 meeting of Applied Physics Society.

20150/9365

CSO: 4306/3596

- END -