

**NAVAL POSTGRADUATE SCHOOL**  
**Monterey, California**



**THESIS**

**INSTRUMENTING THE NAVAL POSTGRADUATE SCHOOL GLOBAL  
BROADCAST SERVICE TESTBED FACILITY**

by

John A. Watkins

June 1997

Thesis Advisor

Paul H. Moose

**Approved for public release; distribution is unlimited.**

**DTIC QUALITY INSPECTED 3**

19980223 139

**REPORT DOCUMENTATION PAGE**

Form Approved OMB No. 0704-0188

Public reporting burden for this collection of information is estimated to average 1 hour per response, including the time for reviewing instruction, searching existing data sources, gathering and maintaining the data needed, and completing and reviewing the collection of information. Send comments regarding this burden estimate or any other aspect of this collection of information, including suggestions for reducing this burden, to Washington Headquarters Services, Directorate for Information Operations and Reports, 1215 Jefferson Davis Highway, Suite 1204, Arlington, VA 22202-4302, and to the Office of Management and Budget, Paperwork Reduction Project (0704-0188) Washington DC 20503.

1. AGENCY USE ONLY (Leave blank)		2. REPORT DATE June 1997	3. REPORT TYPE AND DATES COVERED Master's Thesis	
4. TITLE AND SUBTITLE TITLE OF THESIS Instrumenting the Naval Postgraduate School Global Broadcast Service Testbed Facility			5. FUNDING NUMBERS	
6. AUTHOR(S) John A. Watkins				
7. PERFORMING ORGANIZATION NAME(S) AND ADDRESS(ES) Naval Postgraduate School Monterey CA 93943-5000			8. PERFORMING ORGANIZATION REPORT NUMBER	
9. SPONSORING/MONITORING AGENCY NAME(S) AND ADDRESS(ES),			10. SPONSORING/MONITORING AGENCY REPORT NUMBER	
11. SUPPLEMENTARY NOTES The views expressed in this thesis are those of the author and do not reflect the official policy or position of the Department of Defense or the U.S. Government.				
12a. DISTRIBUTION/AVAILABILITY STATEMENT Approved for public release; distribution unlimited			12b. DISTRIBUTION CODE	
13. ABSTRACT (maximum 200 words) The work reported in this thesis used readily available components to implement a data acquisition system for a Global Broadcast Service Testbed data collection facility. Use of hardware with controlling software is necessary to collect signal power content of satellite signals at a given distance from the transmitting source. Precise measurement and calibration of a satellite receive signal is accomplished by use of an Hewlett-Packard 8568B spectrum analyzer. A personal computer is used to collect and store retrieved data. These components are brought together using LabVIEW instrumentation software. This system provides an efficient means to collect signal data which can be used to verify satellite link performance estimates. Calculations are performed using Matlab statistical analysis software. This thesis contains calculated and measured values of total average carrier power and background noise levels for the three satellite receive systems that comprise the Naval Postgraduate School Global Broadcast Service Testbed facility.				
14. SUBJECT TERMS. Satellite, GBS, DVB, DSS, Link Budget, Carrier Power, Background Noise Power, LabVIEW software, Matlab software, Instrumentation report			15. NUMBER OF PAGES 125	
			16. PRICE CODE	
17. SECURITY CLASSIFICATION OF REPORT Unclassified	18. SECURITY CLASSIFICATION OF THIS PAGE Unclassified	19. SECURITY CLASSIFICATION OF ABSTRACT Unclassified	20. LIMITATION OF ABSTRACT UL	

NSN 7540-01-280-5500

Standard Form 298 (Rev. 2-89)  
Prescribed by ANSI Std Z39-18 298-102



Approved for public release; distribution is unlimited.

**INSTRUMENTING THE NAVAL POSTGRADUATE SCHOOL GLOBAL  
BROADCAST SERVICE TESTBED FACILITY**

John A. Watkins  
Lieutenant, United States Navy  
B.A., University of San Diego, 1990

Submitted in partial fulfillment of the  
requirements for the degree of

**MASTER OF SCIENCE IN INFORMATION TECHNOLOGY MANAGEMENT**

from the

**NAVAL POSTGRADUATE SCHOOL  
June 1997**

Author:

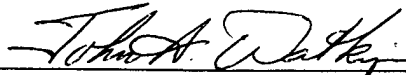

John A. Watkins

Approved by:

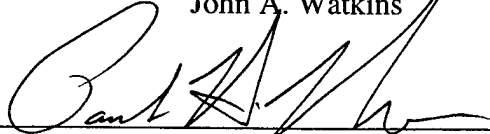

Paul H. Moose, Thesis Advisor



Carl R. Jones, Associate Advisor



Reuben T. Harris, Chairman, Department of Systems Management



## ABSTRACT

The work reported in this thesis used readily available components to implement a data acquisition system for a Global Broadcast Service Testbed data collection facility. Use of hardware with controlling software is necessary to collect signal power content of satellite signals at a given distance from the transmitting source. Precise measurement and calibration of a satellite receive signal is accomplished by use of an Hewlett-Packard 8568B spectrum analyzer. A personal computer is used to collect and store retrieved data. These components are brought together using LabVIEW instrumentation software. This system provides an efficient means to collect signal data which can be used to verify satellite link performance estimates. Calculations are performed using Matlab statistical analysis software. This thesis contains calculated and measured values of total average carrier power and background noise levels for the three satellite receive systems that comprise the Naval Postgraduate School Global Broadcast Service Testbed facility.



## TABLE OF CONTENTS

I. INTRODUCTION.....	1
A. BACKGROUND.....	1
B. THESIS OBJECTIVES.....	3
II. PERFORMANCE ISSUES.....	5
A. SATELLITE COMMUNICATIONS THEORY .....	5
1. Link Budgets .....	6
a. Distance from Satellite Orbit.....	8
b. Radio Frequencies .....	9
c. Antennas .....	9
d. Power Amplifiers .....	10
e. Transmission Losses.....	10
f. Noise Temperature.....	11
B. FACTORS AFFECTING PERFORMANCE OF NPS GBS TESTBED .....	11
1. Signal power and Effective Isotropic Radiated Power.....	11
a. Signal Power.....	11
b. Effective Isotropic Radiated Power.....	13
2. Noise.....	14
a. Antenna Noise .....	15
b. Transmission Line Loss.....	15
c. Amplifier Noise .....	17
d. Total System Noise .....	18

3. Eb/No .....	19
C. PERFORMANCE OF GBS SBS-6, DSS, AND DVB .....	19
1. Estimated Link Budgets for SBS-6. Echostar, and DSS Satellites .....	20
2. Satellite Footprints for SBS-6. Echostar, and DSS .....	24
a. Satellite footprint of SBS-6 .....	25
b. Satellite footprint of DVB .....	26
c. Satellite footprint of DSS .....	27
III. NPS INSTRUMENTATION TESTBED CONFIGURATION.....	29
A. HARDWARE .....	29
1. Integrated Receiver Decoder (IRD) / Low Noise Block (LNB).....	33
2. Receive Antennas for GBS, DVB, and DSS .....	34
3. Firebird 6000 Bit Error Analyzer .....	36
4. BTSA Spectrum Analyzer.....	37
5. HP 8566B Spectrum Analyzer .....	37
6. Personal Computer .....	40
B. SOFTWARE .....	40
1. National Instrument's LabVIEW Software Version 4.0.....	40
2. Matlab Statistical Analysis Software Version 4.2.....	41
IV. METHODOLOGY.....	43
A. LABVIEW® SOFTWARE .....	43
1. Virtual Instrumentation .....	44
2. Virtual Instrumentation Design for Data Acquisition .....	44

a. Requirements.....	44
3. Basics of Virtual Instrumentation using LabVIEW.....	45
a. Front Panel and Block Diagram .....	45
b. LabVIEW Menus.....	46
c. Creating Objects .....	47
d. Quick Access to Controls and Functions .....	47
e. LabVIEW Tools.....	47
f. Saving VIs.....	48
g. Opening and Closing VIs .....	48
h. Running VIs .....	49
4. GBSTESTBED.VI.....	50
a. Front Panel of GBSTESTBED.VI.....	50
b. Block Diagram of GBSTESTBED.VI.....	53
5. GBSSUB.VI .....	62
a. Front Panel of GBSSUB.VI.....	63
b. Block Diagram of GBSSUB.VI.....	68
6. VI Hierarchy.....	71
<b>B. RECORDING DATA.....</b>	<b>73</b>
1. Data Formats .....	73
2. Sampling Size.....	77
3. Sampling Frequency.....	78
<b>C. MATLAB.....</b>	<b>78</b>

1. Datafilter Function .....	79
2. Stage 1 Function.....	80
3. RG-11 Function.....	81
4. Intpwr Function .....	82
V. DATA RESULTS.....	85
A. DSS SATELLITE SIGNAL.....	85
B. DVB SATELLITE SIGNAL.....	88
C. HUGHES SBS-6 SATELLITE SIGNAL.....	91
D. ANALYSIS.....	93
VI. SUMMARY.....	97
APPENDIX A. CALCULATION OF RECEIVE ANTENNA ELEVATION ANGLES.....	99
APPENDIX B. CALCULATION OF TOTAL SYSTEM NOISE LEVELS.....	101
LIST OF REFERENCES.....	105
INITIAL DISTRUBUTION LIST.....	107

## LIST OF FIGURES

1. Displaying a typical Satellite to Ground Receive Station Link.....	6
2. Typical Link Budget for a common Satellite System.....	7
3. Power Received from an Isotropic Transmitter .....	12
4. EIRP Coverage of SBS-6 Satellite .....	25
5. EIRP Coverage of Echostar Satellite .....	26
6. EIRP Coverage of DSS Satellite .....	27
7. KG Room rack mounted equipment for GBS CONUS Testbed .....	30
8. GBS CONUS Testbed Receive Suite .....	32
9. Typical Set-up with Receive Antenna LNB and IRD .....	34
10. Receive Antennas on top of Root Hall.....	35
11. Fireberd 6000 Bit Error Rate Test Equipment .....	37
12. HP8568B Spectrum Analyzer .....	39
13. Front Panel of the GBSTESTBED.VI .....	51
14. Block Diagram for the GBSTESTBED.VI .....	54
15. GPIB Address Box and HP8591A Read Axis VI .....	56
16. Transgression Path for the GBSTESTBED.VI .....	57
17. Format and Append Case Structure .....	59
18. Input Specifications to Concatenate Function .....	61
19. Text File Function VI Up-close.....	62
20. Front Panel of GBSSUB.VI .....	64
21. Frequency Case Structure of GBSSUB.VI Block Diagram .....	69
22. Input box for Modifying Sample Size Criteria.....	71
23. VI Hierarchy .....	72
24. Output Data File with Header Information .....	77
25. DSS Satellite Signal .....	85
26. Carrier Power for DSS Channel 1 and 16 of the DSS Satellite Signal .....	86
27. Background Noise Levels for the DSS Satellite Signal .....	87
28. Echostar DVB Satellite Signal .....	88
29. Carrier Power for DVB Channel 1 and 10 of the DVB Satellite Signal .....	89
30. Background Noise Levels for the DVB Satellite Signal .....	90
31. Hughes SBS-6 Satellite Signal.....	91
32. Carrier Power for Hughes SBS-6 Satellite Signal.....	92
33. Background Noise Levels for the Hughes SBS-6 Satellite Signal.....	93



## LIST OF TABLES

1. Total System Noise Temperatures.....	18
2. Estimated Clear Sky Link Budgets.....	20
3. Atmospheric Losses of the GBS SBS-6, DVB, and DSS Transmissions .....	21
4. Rain Loss for the DSS System .....	22
5. Rain Loss for the SBS-6 GBS CONUS System.....	23
6. Rain Loss for the Echostar DVB System .....	24
7. Format Specifications for LabVIEW Output Data.....	75
8. Codes for Inserting Non-displayable Characters into Output Data.....	76
9. Theoretical versus Measured: Carrier and Noise Power.....	94



## ACKNOWLEDGMENT

There are several people whom I would like to thank for their extraordinary willingness to assist me in my research for this thesis. I first want to acknowledge the Electrical and Computer Engineering Department, particularly Jeff Knight, for his unwavering support and assistance in learning and programming with the LabVIEW software application. He has been extremely generous in providing me with information and guidance throughout my research efforts. Additionally, I would like to thank Hank Hankins for his diligence in ensuring full systems operation of the GBS Testbed. I also would like to express my sincere thanks to Professor Colin Cooper for his technical assistance in programming with Matlab software. I am especially grateful to Dr. Paul Moose, of the Naval Postgraduate School, for his expert guidance and input while researching and writing this thesis. Finally, I reserve my biggest thanks to my wife Michelle whose support and patience through this experience are so very much appreciated.

## I. INTRODUCTION

### A. BACKGROUND

Operation Desert Storm and exercises since then have shown that joint operations require increased satellite communications capacity. Currently, the military communications satellite constellation is oversubscribed and is not designed to deliver high volume, continuous information to multiple users. With existing military constellations requiring replenishment in the years 2003-2007, DOD plans are ongoing to acquire new technologies to augment and/or replace current systems for future satellite communications architectures [Ref. 1]. The Direct Broadcast Satellite (DBS) system is one such system now being tested and fielded for use in military applications.

In the mid 1990's, Hughes Communications and the United States Satellite Broadcasting Company (USSB) launched a new generation of television service to North America. This service, known as Direct Satellite Service (DSS), distributes many channels of high quality digital video, as well as digital audio and data via Direct Broadcast Satellites (DBS) to small (18' diameter) dishes and decoders that are purchased by the consumer. In February 1995, the Deputy Assistant Secretary of Defense for C4I hosted a DOD conference to discuss concepts and plans for DBS capability within the military. In an effort to avoid confusion with the commercial DBS systems, the DOD concept was officially renamed the Global Broadcast Service (GBS) [Ref. 2].

An emerging technology, Direct Broadcast Satellites (DBS) have overcome several technological barriers to become commercially viable to provide laser disk picture quality as well as CD sound to subscribers. Specific enabling technologies are the video compression techniques using the Moving Pictures Expert Group (MPEG) algorithms, high power satellite transponders, inexpensive low noise microwave receivers, and affordable high speed digital processors. The potential benefits of DBS technology for the military are tremendous. A military GBS is ideally suited to the DOD's need for extensive bandwidth using existing technology that is both affordable and highly capable. The high data rates and large bandwidth associated with these types of satellites can be exploited to provide simplex transmission of imagery, television, and data to a variety of users. However, there are major differences between commercial use and military use of DBS. For example, commercial programming is done months in advance and broadcasts

are limited to TV and audio. Additionally, the encryption incorporated in commercial broadcasts is to discourage nonsubscribers from accessing this service. The military will require full encryption to ensure security of classified information. Likewise, the 18' dishes that receive these signals are suitable for receptions at home, but the military will require reception in less ideal circumstances. In particular, the mobile user will need a system that will allow reception on the move. There are proposals for interim and final solutions to provide a GBS for the military. The implementation of these solutions will require answering several questions such as the frequencies to be used, the type of satellite to be employed (light satellite or modification of current satellite program), the organization of the broadcast management center, encryption methods, and more importantly here, the reception quality of transmission.

Commercial industry has developed the capability to broadcast a high volume of data with the use of very small aperture antennas coupled with affordable receiving equipment. This technology is easily adaptable to military communications needs. The technology embodied in commercial direct broadcast service (DBS) can be modified with additional DOD investment to serve the needs of the mobile user on the move [Ref. 1]. The effort to modify and incorporate DBS technology is the backbone to the Global Broadcast Service (GBS) initiative. The use of DBS to disseminate information provides a tremendous gain over the current data rates available to disadvantaged users on the move. Using high powered satellites to broadcast digital information to small aperture antennas and inexpensive terminals, data rates ranging from 23 to 30 Million Bits Per Second (Mbps) are possible [Ref. 3]. However, there are limitations to this approach, particularly in providing these data rates to a user on the move.

The GBS system will be comprised of information sources, up-link transmission sites, broadcast satellites, and receiver terminals as well as management processes for requesting and coordinating the distribution of information products. Each GBS satellite will be serviced by a primary up-link site where information products are assembled and transmitted to a high-powered satellite for relay to users over a large geographical area.

The development and deployment of GBS is to be accomplished in three phases.

Phase I (FY96-98)—Limited Demonstration: leased commercial satellite transponders operating at Ku-band, used primarily for concept of operation (CONOPS) development, demonstration, and limited operational support. Transponders are being

leased on two satellites: Orion I for service to IFOR in Bosnia and Hughes SBS-6 for CONUS GBS CONOPS development.

Phase II (FY98-00) Interim Military Satellite Capability: Initial fielding of GBS packages on UFO Follow On Satellites Nr 8, 9, and 10. Acquiring user terminals and information management systems. Integration of GBS with Defense Information Infrastructure and complete connectivity with various providers of high-volume information.

Phase III (FY00-02) Objective system: Fielded systems will be upgraded with objective requirements with satellite constellation that will provide worldwide coverage. Complete integration with GCCS and other intelligence broadcast and theater information management systems.

This thesis focuses on issues being evaluated and researched in conjunction with Phase I of the GBS process implementation. It analyzes and evaluates the limited demonstration of leased commercial satellite transponders operating at Ku-band, used primarily for concept of operation (CONOPS) development, demonstration, and limited operational support. The author evaluates the performance of three different satellite communications systems; specifically, the GBS SBS-6, Echostar Dish Network, and the DBS DSS satellites. Experimental research on critical technical and functional aspects of the NPS GBS Testbed to include instrumentation analysis and monitoring results of the received carrier power and background noise levels on each transponder associated with the GBS broadcast satellite, the Echostar Digital Video Broadcast (DVB) satellite, and the DSS satellite signals are provided. Continuous estimates of C/N at the input to the Integrated Receiver Decoder (IRD) are provided for each system. Additionally, comparisons of measured data in the form of calculated versus estimated link budgets inherent to the GBS, Echostar, and DSS systems are provided.

## **B. THESIS OBJECTIVES**

The primary objectives of this thesis are two fold. The first objective of this thesis was to construct and synthesize a satellite signal collection and analysis facility, using readily available components, which could collect and record satellite signal power spectrum measurements. The second, to provide a limited statistical analysis report of the

GBS, DVB, and DSS reception quality at the NPS GBS Testbed based on the data amassed by the collection facility .

Using the recorded signal power spectrum content from the collection facility, link budget computation can be reconstructed and compared with estimated link budgets for determining the performance of various satellite communications systems. The collection facility is needed in order to confirm that previously calculated link parameters are valid and reasonable and that predicted link performance of a particular system is accurate. The collection facility described here enables numerous sets of specific satellite communications system signal power spectrum data to be collected using various combinations of transmitters and receivers. The data collection facility can be reconfigured or modified to accommodate user-defined requirements.

Chapter II of this thesis consists of an explanation of satellite communications theory, including a description of satellite link budget components and the factors that affect satellite link performance. Chapter III provides the reader with a description of the hardware and software components that make up the NPS Testbed facility. Concept, design, operation, and graphical source code of the data acquisition system developed for the Testbed using LabVIEW software, is described in Chapter IV. Chapter V provides a limited instrumentation report on the link performance of the three satellite communications systems that comprise the NPS Testbed. These include the average received signal power and expected background noises for each system. Graphical display of the signal power spectrum content and noise spectrums are provided. Following the summary presented in Chapter VI, Appendices A and B, contain calculations of specific performance criteria made throughout this writing.

By using this thesis, and the information in the appendices, future GBS users are able to assess and utilize baseline estimates of received carrier power and expected background noise levels for the GBS, DSS, and DVB systems. Furthermore, the calculated link budgets provided can be used for comparison to future data accumulation and analysis. It is strongly suggested that the information contained in this thesis be utilized in further testing and analysis congruent with the GBS implementation process.

## II. PERFORMANCE ISSUES

This chapter addresses factors that effect satellite transmission performance. It is important to understand the basic theory behind satellite transmissions before addressing the factors that effect received signal power strength. Chapter II will begin with a brief description of a telecommunications satellite system and then discuss the following performance measures inherent to a satellite communications system link budget calculation:

- Signal Power and Effective Isotropic Radiated Power (EIRP)
- Ground Receive Terminal Noise
- Noise in instrumentation devices
- Energy per bit

Having presented these, this chapter will then address factors that affect signal reception quality. Finally, estimated link budgets using Satellite Tool Kit (STK) software and satellite footprint(s) (EIRP coverage) for each system will be presented and discussed.

### A. SATELLITE COMMUNICATIONS THEORY

Most communication satellites are active repeaters. The equipment in the satellite receives signals from an earth station, translates them to a different frequency, and amplifies them for retransmission to one or more earth stations. The communications package in the satellite includes a number of transponders in adjacent frequency bands each of which performs these functions. The signal power received at the satellite from the earth station is very weak. Consequently, the satellite must have a means of greatly amplifying the received signal and then transmitting it at a new higher power level to earth. Likewise, the signal power at the receive earth station is very weak. The receiving earth station must receive this weak signal, amplify it, and obtain a signal that is sufficiently clear to be decoded. Figure 1 below displays a typical satellite uplink and downlink configuration.

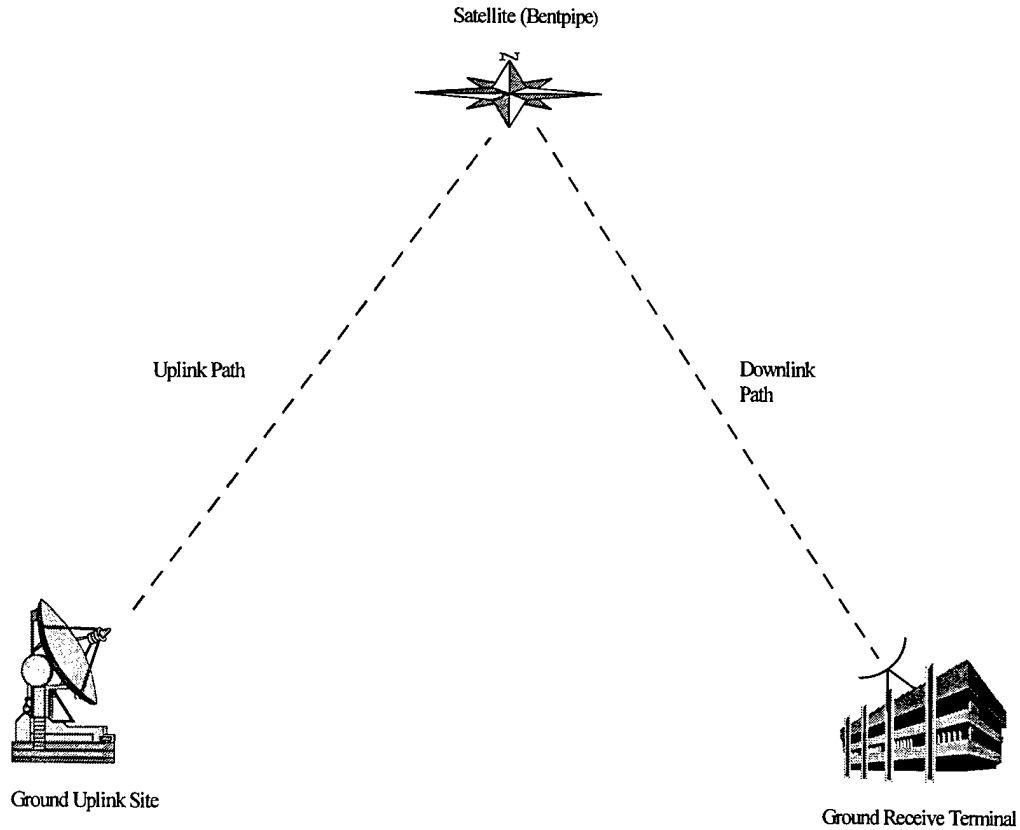

Figure 1. Displaying a Typical Satellite to Ground Receive Station Link

## 1. Link Budgets

The performance parameters of a communications satellite are typically presented in a link budget. Many factors affect the signal transmission. Each of these is an input to the link budget. A link budget includes parameters of both the space segment (the satellite) and the ground segment (the earth station). The uplink includes the earth station transmitter and the satellite receiver. The downlink includes the satellite transmitter and the earth station receiver. Figure 2 shows a typical link budget for the Hughes DSS DirecTV system. Notice that calculations are made for both the uplink and the downlink transmission paths. The terms within Figure 2 will be defined and discussed throughout the remainder of this chapter.

### Typical DSS DirecTV Link

<b>Link Environmental Conditions</b>			
	Clear	Rain up	Rain down
<b>Uplink</b>			
Transmit EIRP, dBW	76	86	76
Uplink path loss, dB	-208.9	-208.9	-208.9
Atmospheric Loss, dB	-0.3	-0.3	-0.3
Uplink rain loss, dB	0	-2	0
Satellite G/T, dB/K	3	3	3
Bandwidth, dB-Hz	-73.8	-73.8	-73.8
Boltzmann's Constant, dBW	228.6	228.6	228.6
Uplink C/N, Thermal, dB	24.6	14.6	24.6
<b>Downlink</b>			
Transmit EIRP, dBW	51	51	51
Downlink path loss, dB	-205.9	-205.9	-205.9
Atmospheric loss, dB	-0.1	-0.1	-0.1
Downlink rain loss, dB	0	0	-1.8
Rain temp increase, dB	0	0	-2.4
Pointing loss, dB	-0.3	-0.3	-0.3
Ground G/T, dB/K	13	13	13
Bandwidth, dB-Hz	-73.8	-73.8	-73.8
Boltzmann's Constant, dBW	228.6	228.6	228.6
Downlink C/N, Thermal, dB	12.5	12.5	8.3
<b>Totals</b>			
Uplink C/N (thermal), dB	24.6	14.6	24.6
Downlink C/N (thermal), dB	12.5	12.5	8.3
Crosspol Interference, dB	23.6	22.8	23.1
Adjacent Sat Interference, dB	20.9	20.8	20.9
Total C/(N + I), dB	11.4	9.8	7.8
<b>Total Eb/No, dB</b>	<b>11.5</b>	<b>9.9</b>	<b>7.8</b>
<b>Required Eb/No, 10<sup>-10</sup> BER</b>	<b>5.1</b>	<b>5.1</b>	<b>5.1</b>
<b>Link Budget (for Chicago)</b>	Low Power Transponder/Low-Info Rate Mode		

Figure 2. Typical Link Budget for a common Satellite System  
(Ref: Data taken from DirecTV, Inc.)

The input parameters found in the link budget above are described in the following sections. Notice that the uplink and downlink more or less contain the same variables. The Effective Isotropic Radiated Power (EIRP) is the transmit power of the

ground station transmission antenna in the uplink; in the downlink, it is the transmit power of the satellite. Both uplink and downlink have free space path loss associated with transmission. This is a function of the distance from the transmitting source to the satellite and the uplink frequency used in the case of the uplink, and the distance from the ground receive antenna to satellite and downlink frequency in the downlink. Atmospheric and rain losses may be present in the uplink, the downlink, or both. Both atmospheric and rain losses vary as a function of the elevation angle and the frequency of the signal being transmitted. Losses increase for higher frequencies. In the uplink, satellite G/T refers to the antenna gain and noise temperature of the satellite receiver. Conversely, the G/T value in the downlink refers to the gain of the receive antenna and noise temperature at the terminal receive station. Boltzman's constant applies to both the uplink and downlink and bandwidth is pre-established by the system data rate and modulation techniques used. The values for carrier-to-noise (C/N) in both the uplink and downlink refer to the ratio of signal power received to noise power in the same bandwidth and is presented in dB. Finally, an important measurement of performance for a digital satellite system is the ratio of energy per bit ( $E_b$ ) over noise power per unit bandwidth (in hertz). This is expressed as  $E_b/N_0$ . The energy per bit  $E_b$  is the carrier power divided by the data rate in bits per second. Digital communications systems by nature, must have sufficient  $E_b/N_0$  in order to maintain errors below a certain bit error rate (BER). Bit error rate and  $E_b/N_0$  are also discussed in the following sections.

*a. Distance from Satellite Orbit*

An important input in the link budget is the distance between the satellite and the earth receive station. This distance is called the slant range  $S$ . For geostationary satellites it varies between 35,786 and 41,680 km. The major effect of distance is the inverse relationship between the received signal power and the square of the distance  $S$ . The long distance between the satellite and the earth receive station also produces a significant time delay, so the usual satellite circuit (the uplink and downlink for each direction) has a delay of more than 1/4 second. The orbit affects satellite performance in other ways. Transmission of the signal through the atmosphere is affected by the elevation angle. This is the angle between the radio frequency (RF) link and the horizontal plane. For low elevation angles (satellite near the horizon) the signal must traverse more atmosphere. This causes additional transmission losses.

As stated earlier, the NPS GBS Testbed is comprised of three satellite receive systems using the GBS SBS-6, DVB Echostar, and DSS DirecTV satellites. All three of these satellites orbit at a distance of 35,786.30 kilometers above the equator. Receive antenna elevation angles are 24.69° for the GBS SBS-6 1 meter dish, 47.43° for the DVB 18' antenna, and 42.18° for DSS 18' inch antenna respectively. Refer to Appendix A for calculations of antenna elevation angles.

***b. Radio Frequencies***

Frequency bands for communications satellites are allocated by the International Telecommunications Union (ITU) and its committees and conferences. The ITU also allocates longitudes in the geostationary arc. Technical factors that affect the choice of frequency band include atmospheric transmission, antenna gains and beamwidths, and availability of equipment.

Many communication satellite systems use C-band (6 and 4 GHz) and Ku-band (14 and 12 GHz). These are fixed-satellite service (FSS) allocations. Other bands are used for broadcast services, mobile services, and military satellites. The limitation of available spectrum has driven technology in several ways. Frequencies are reused by multiple satellites, multiple beams, and dual polarization. The K/Ka-band (20 and 30 GHz) spectrum is not so crowded, and has more available bandwidth.

All three systems currently in operation and that are being tested in the NPS GBS Testbed utilize the Ku-band (14 and 12 GHz) frequency spectrum. Next year, with the launching of Hughes satellite UFO 8, GBS Phase II will be shifted to the higher frequency Ka/K-band.

***c. Antennas***

The most common antennas used with communications satellites are parabolic antennas. In a receive antenna, the RF power is focused by the reflector onto a feed horn connected to a Low Noise Amplifier (LNA). The signal is down converted to a lower frequency (in GBS to L-band (1GHz)) and then forwarded to a digital receiver, referred to as the Integrated Receiver Decoder (IRD), via a transmission line. In a transmit antenna the power exits from the feed horn to the reflector, which radiates it in the pointing direction. An antenna is a reciprocal device, and the transmit and receive functions are similar [Ref. 4].

The antenna gain  $G$  is the ratio of the power transmitted in the preferred direction compared to that of an isotropic transmitter (transmission in all directions). Earth receive station antennas usually have a single feed, since they focus on a single satellite with maximum gain. Each of the three systems being tested at the NPS GBS Testbed use parabolic receive type antennas which operate according to the description provided above.

*d. Power Amplifiers*

The function of the power amplifier is to increase the signal power for transmission into space. In a satellite the restrictions on mass and available DC power usually limit the transmitter power to 10 to 100 W. However, in DBS satellites, power levels of 120W to 240W are achieved. In an earth transmission station, the restrictions are less stringent, and a transmitter power of 1000 W or more is easily achieved. Many satellite power amplifiers use traveling wave tubes (TWTs). These are vacuum tubes with an electron beam interacting with a traveling RF wave. Consequently, power amplifiers dissipate considerable heat. Dissipating this heat in space is more difficult due to the lack of air. Earth transmit stations often have more input power available, and may use klystrons as well as TWTs [Ref. 4].

*e. Transmission Losses*

The greatest reduction in transmitted power is due to the long distance between the satellite and the earth transmit/receive station (recall that this distance is referred to as the slant range  $S$ ). The attenuation due to this long distance is called free space path loss  $L$  and is given by

$$L = \frac{(4\pi S)^2}{\lambda^2} \quad (2.1)$$

where  $\lambda$  is the wavelength.

Other losses in transmitted power are much smaller. Atmospheric losses are usually small, but may become significant based on the geographical location of the earth receive station. Atmospheric losses increase for higher frequencies and with precipitation in the air, especially tropical cloudbursts. Other transmission losses are due to errors in pointing the antenna and in polarization mismatch.

*f. Noise Temperature*

Lastly, one must also account for noise. One source of noise is natural RF noise emitted from the background. A satellite antenna receiving signals from an earth station will also receive RF noise from the earth. The noise power is roughly proportional to the temperature of the object (in this case the earth). For earth this temperature is typically around 270 Kelvin.

Normally an earth station antenna is pointed at space, and so it has a much lower noise temperature. Other noise sources in the receiver predominate. The noise power can still be equated to a value of noise temperature, even though there is no physical object at that particular temperature. The sun having a very high temperature causes noise insertion to the extent that for a few times each year it is seen directly behind a geostationary satellite. At those times, the noise temperature is so high that communication is often interrupted. Therefore, most communication satellite links suffer a brief "station-sun interference" outage a few times a year [Ref. 4].

**B. FACTORS AFFECTING SATELLITE PERFORMANCE OF NPS GBS TESTBED**

This section discusses factors which effect the carrier-to-noise ratios, and therefore, limit individual system capacity of the systems in the NPS GBS Testbed.

**1. Signal Power and Effective Isotropic Radiated Power**

*a. Signal Power*

Since the NPS Testbed is a ground receive station, the discussion on signal power will be limited to the satellite downlink only. Note however, that the signal power computation applies equally for the uplink as well. When dealing with signal power, a satellite communication system must be designed such that its satellite will deliver sufficient signal power relative to noise so as to ensure that the system achieves a required BER at the selected bit rate.

To begin illustrating the calculation of signal power, conceptualize a scenario using some given assumptions and concepts. First imagine the light emitting from a flashlight bulb with no reflector in place. The light is transmitted equally in all directions in a manner referred to as isotropic radiation. The objective is to determine the

illumination power received at a distant receiving antenna, when the power into the antenna flange at the transmitter is  $P_t$ . The area in which the receive antenna resides is  $A_e$  (on the earth's surface). Assume that the surface area  $A_e$  is perpendicular to the transmitted illumination power, such that the power transmission is normal to the surface area  $A_e$ . The slant range  $S$  is the distance between the illumination source (the light bulb), and the earth's surface area  $A_e$  (the receiver). Refer to figure 3 for a diagram depiction of power received at surface area  $A_e$ . Using this spherical model, the transmitter is centrally located within the sphere. The radius  $S$  displays the distance from the transmitter to the receiver area. The total surface area of the sphere is  $4\pi S^2$ . The transmitted power  $P_t$  is spread uniformly over the surface area due to its isotropic transmission. The power density is constant over the area  $A_e$  and is determined by  $P_t/4\pi S^2$  [Ref. 4].

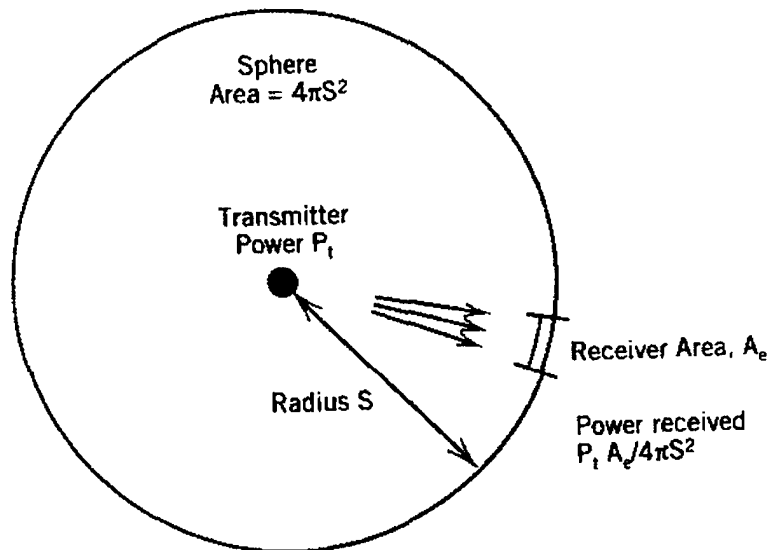

Figure 3. Power Received from an Isotropic Transmitter

A receive antenna located within the surface area  $A_e$  will intercept some of this power, proportional to its effective area of  $A_e$ . Then the power received  $C$  is

$$C = \frac{P_t A_e}{4\pi S^2} . \quad (2.2)$$

The power is denoted by  $C$  because later it will be referred to as the carrier power of the signal.

Now if we add a reflector to the flashlight and point the flashlight at the receive antenna, this will increase the received light. Similarly, earth station and communications satellite transmitters use an antenna reflector to increase the received power. This increase is a certain ratio  $G_t$ , called the gain of the transmit antenna. Incorporating  $G_t$  into equation (2.2) we now can write the received power as

$$C = \frac{P_t G_t A_e}{4\pi S^2} . \quad (2.3)$$

If the receive antenna is not 100% efficient, the effective area  $A_e$  is not the actual physical area  $A$ , but somewhat less. One major input to a link budget are the parameters shown in (2.3).

Prior to explaining the next phase in link budget calculations, it is important to keep in mind some general considerations associated with link budget derivation. These are the following:

1. Calculations are done using a logarithmic scale, in decibels, rather than with absolute numbers.
2. The performance of the receive antenna is expressed as an antenna gain  $G_r$ , which is related to the effective area.
3. The absolute value of received carrier power  $C$  does not determine performance by itself. The true performance is measured by comparing the received power to any noise that may be present.
4. Many small effects, such as atmospheric attenuation, tracking errors, antenna patterns, and feed horns and cables produce additional losses.

#### ***b. Effective Isotropic Radiated Power***

Recall from above, that  $G_t$  is the gain of the transmitting antenna in the direction in which the maximum power is radiated. It is a measure of the increase in power radiated by the antenna over that radiated from an isotropic source (in the above scenario—light bulb without reflector).  $P_t$  is amplified by the gain of the transmit antenna  $G_t$  to deliver what is referred to as effective isotropic radiated power (EIRP).

This is  $P_t \times G_t = \text{EIRP}$ . Since we have now arrived at an equation for EIRP, we can represent the signal power which reaches the receive antenna as

$$\Omega = \frac{\text{EIRP}}{4\pi S^2} \quad (2.4)$$

where  $\Omega$  is the power flux density at the receive antenna. The gain of the receive antenna is given by

$$G_r = \frac{4\pi A_e}{\lambda^2} \quad (2.5)$$

where  $\lambda$  is the wavelength of the transmitted signal and  $A_e$  is the effective aperture of the receive antenna. The received power is given by

$$C = A_e \times \Omega \quad (2.6)$$

With minimal substitution, we arrive at

$$C = \frac{\text{EIRP} \times G_r}{(4\pi S/\lambda)^2} \quad (2.7)$$

The term  $(4\pi S/\lambda)^2$  is referred to as the free space path loss  $L$ .

A primary objective of this thesis is determining the average carrier power received from the GBS SBS-6, DVB, and DSS satellite systems at the NPS Testbed site.

## 2. Noise

In an isothermal environment the minimum noise power  $N$  is  $kTB$ , the product of Boltzmann's constant  $k$ , temperature  $T$ , and bandwidth  $B$ . Realistically, the environment is not isothermal, and noise comes from multiple sources. The noise  $N$  is typically characterized by a system noise temperature  $T_{\text{sys}}$ . In link budgets it is common to calculate the ratios  $C/kT_{\text{sys}}$ , and  $C/kT_{\text{sys}}B$ . The latter two quantities are also labeled  $C/N_0$  and  $C/N$ , respectively [Ref. 4].

The NPS GBS Testbed is instrumented to measure carrier powers and the background noise added by various noise sources.

**a.     *Antenna Noise***

Common parabolic antennas like those used in the NPS GBS Testbed insert noise contributions from the surroundings. Such contributions come from cosmic noise, galaxy, troposphere, ionosphere, and precipitation. When such antennas are designed, efforts are made to reduce the side-lobe and back-lobe characteristics inherent to these types of antennas. This effort is made in order to reduce the noise from off-axis sources. The antenna (sky) noise temperature is a weighted composite of the following:

- Cosmic background noise at RF (about 2.76 K)
- Galactic noise
- Noise temperature due to precipitation in the path
- Solar noise
- Presence of the earth (typically at 290 K) in a side-lobe
- Contribution of nearby objects, buildings, and radomes
- Temperature of blockage items in the antenna subsystems

The usual noise temperature, seen by an earth receive station antenna, is that of the sky. The clear sky temperature is frequency dependent. It includes contributions for the troposphere, the galaxy, and the space beyond. The NPS GBS Testbed receive antennas are affected in varying degrees by the phenomenon mentioned above. In particular, the antenna noise is effected by the relatively low elevation angles of the receive antennas located on top of Root Hall, a building at NPS. It was found during testing that the contribution of noise from nearby buildings (Spanagel Hall) and foliage in line with the antenna view path, is a significant factor.

**b.     *Transmission Line Loss***

The transmission line that connects the receive antenna and low noise block (LNB) to the IRD introduces losses and also contributes to the system noise temperature. Line losses include those in the transmission line itself and those in the connectors/adaptor fittings. The NPS GBS Testbed uses RG-11 coaxial cable which is

rated at an insertion loss of approximately 5 dB per 100' feet of cable at 1 GHz. Average calculated loss from the RG-11 coaxial cable and a fixed number of F-type and BNC type connectors was found to be 12.8 dB at 1 GHz across all three systems. The loss was calculated by measuring the signal strength received at the LNBS (on top of Root Hall) for each system. First, the RG-11 cable was removed from the socket connection into the LNBS. A short length of RG-11 test cable was inserted between a HP8590B spectrum analyzer and the LNB socket connection. A recorded trace plot was then taken and stored in the spectrum analyzer's memory. The same procedure was replicated for each of the three systems. After storing the initial trace, the RG-11 cable was connected back to the LNBS completing the link to the Secure System Technology Lab (SSTL) where the IRDs are positioned. The HP 8590B spectrum analyzer was moved to the SSTL where again, signal power readings were taken and stored in the spectrum analyzer's memory. (The reader will note that the final point of measurement was taken prior to the input socket of the IRD.) Comparison of the Trace A to the Trace B plots for each system showed an average line loss value of 12.8 dB for all three systems at 1 GHz.

Other line losses are those associated with connectors and adapters. The estimated losses associated with connectors and adapters (for any system being tested at any time) are approximately 1.7 dB (this is accounting for up to 3 fittings used in making the line connection between the LNB and IRD for any one of the systems). This estimate is based on manufacturer rated insertion loss for particular connectors or adapters (F-type, BNC, and F to BNC each have a manufacture rating of approximately .5 dB loss.)

The losses associated with each specific system are for the most part, equivalent. This is because the lengths of RG-11 coax cable connecting each receive antenna to its respective IRD, are approximately of equal length (225 feet). Roughly, the amount of connectors and adapters used in each system are equal in number (typically 3). An attempt was made to ensure that each system was outfitted with as much as possible, the same number of connectors and adapters—such that calculating insertion loss would be predictable and consistent. The average line loss value of 12.8 dB includes the loss inserted by both connectors and adapters. Line loss may vary among different receive suites because of the differences in cable length and the number of connectors and adapters used. The calculated 12.8 dB average line loss value is NPS GBS Testbed specific.

c. *Amplifier Noise*

Active electronic devices used in the receive system contribute to the total system noise temperature. Amplifiers amplify both the input signal and input noise. The ratio of input signal to input noise would remain the same, except for the noise added by the amplifier itself. When multiple stages are interconnected, subsequent stages typically have less effect than the first element. The effective input noise temperature for a two element receiver is

$$T_{rx} = T_{A1} + T_{A2}/G_1 \quad (\text{K}) \quad (2.8)$$

where  $T_{A1}$  and  $G_1$  are the noise temperature and gain of the first element respectively, and  $T_{A2}$  is the noise temperature of the subsequent element (the gain is expressed as a ratio and not in decibels).

For a more complex system, where there are multiple cascading elements, equation (2.8) becomes

$$T_{rx} = T_{A1} + T_{A2}/G_1 + T_{A3}/G_1G_2 + T_{final}/G_1G_2G_3 \quad (\text{K}) \quad (2.9)$$

where  $T_{A2}$ ,  $T_{final}$ ,  $G_2$ , and  $G_3$  are subsequent noise temperatures and gains of each additional element in the multistage system. The reader will note that the first stage ( $T_{A1}$ ) is the most dominant factor in the equation assuming that all gains are greater than unity. Therefore, it is highly desirable to have a temperature in the first stage as low as possible.

There are many types of low noise RF amplifiers in use in satellite communications systems. Selection of what type of RF amplifier is based upon the environment in which the signal is to be received and the requirements that need to be met at the ground receive station. In order of increasing noise temperature, these are cryogenically cooled parametric amplifiers, thermoelectrically cooled parametric amplifiers, field effect transistor amplifiers, uncooled parametric amplifiers, tunnel diode amplifiers, traveling wave tube amplifiers, and mixers [Ref. 4]. Receiver amplifiers used in the GBS NPS Testbed are of the uncooled parametric amplifier type.

It is critical to note that some noise temperature components increase for higher frequencies. This is particularly noteworthy when considering that the GBS Phase II system will operate in the K/Ka-band frequency spectrum at 20 to 30 GHz. Both DSS

and DVB operate in the Ku-band frequency range and as such, are less prone to noise temperature fluctuations as a function of amplification at the receive end. The current GBS CONUS broadcast via the Hughes SBS-6 satellite also uses the Ku-band. This is important to understand since the data reported in this writing is for the Ku-band only. Future study of the impact on amplifier noise temperature as a function of operating in the Ka-band is fully warranted. Following the launch of Hughe's UFO 8 satellite (scheduled for late FY98), noise temperatures at GBS receiver terminals may be effected considerably due to operating in the Ka-band. Follow-on research at NPS is planned to measure noise temperature when the GBS system shifts to Ka-band.

**d. Total System Noise**

The total system noise for GBS can be expressed as the sum of the three noise temperatures: antenna noise temperature, transmission line noise temperature, and amplifier noise temperature. The total system noise temperature is written as

$$T_{sys} = T_{ant} + T_{lnb} + T_{line}/G_{lnb} + T_{IRD}/G_{line} - G_{lnb} \quad (2.10)$$

where  $T_{ant}$  is the antenna noise temperature,  $T_{line}$  is the transmission line noise temperature,  $G_{line}$  is the gain of the line (less than one),  $T_{lnb}$  is the noise temperature of the LNB,  $G_{lnb}$  is the gain of the LNB amplifier, and  $T_{IRD}$  is the noise temperature of the IRD [Ref. 6]. On a clear day, with an ideal receive antenna, the second factor, the LNB noise temperature, will be dominant. When atmospheric conditions are poor, the first factor, the antenna noise temperature, may become dominant [Ref. 5].

The calculated clear sky system noise temperatures for the three satellite systems at the NPS GBS Testbed are listed below in Table 1. For calculations see Appendix B.

<b>System</b>	<b>Total System Noise Temperature</b>
SBS-6	67.003° K
DSS RCA Network	125.020° K
DVB Echostar	90.210° K

Table1 Total System Noise Temperatures

### 3. $E_b/N_0$

All three systems addressed in this thesis are designed to transmit digital information. An important measure of performance for such systems is the ratio of energy per bit ( $E_b$ ) to noise power per unit bandwidth  $N_0$ . The noise per unit bandwidth  $N_0$  is  $N/B$  or  $kT_{sys}$ . The energy per bit  $E_b$  is the carrier power divided by the bit rate ( $C/r_b$ ). Digital communications systems require sufficient  $E_b/N_0$  in order to maintain a certain bit error rate (BER). The established bit error rate for the GBS SBS-6, DVB, and DSS systems is  $10^{-10}$ . Specific  $E_b/N_0$  measurements are not the objective of this thesis, however, at the time of this writing, research is being conducted in an effort to study and calculate  $E_b/N_0$ (s) for all three systems comprising the NPS GBS Testbed.

The concept of  $E_b/N_0$  is mentioned here because of its significance in determining the performance of satellite systems. Likewise, the link budgets provided in this thesis contain required  $E_b/N_0$  values for each system. When seen in a link budget, the  $E_b/N_0$  required value is subtracted from the actual calculated value in order to determine link margin. The amount of  $E_b/N_0$  margin a particular link maintains determines the robustness of the link.

#### C. PERFORMANCE OF GBS SBS-6, DSS, AND DVB

Having discussed the variables that make up a satellite link budget and the factors that affect link performance, the purpose of this section is to provide estimated link budgets and satellite footprints for each of the three systems in operation at the NPS GBS Testbed. The estimated link budgets presented were developed using the Satellite Tool Kit (STK) software application. An objective of this thesis is to use these estimated link budgets for comparison with actual measurements which are attained through the LabVIEW instrumentation process described in detail in subsequent chapters.

# 1. Estimated Link Budgets for SBS-6, Echostar DVB, and DSS Satellites

Estimated Linkbudget SBS-6 Satellite		Estimated Linkbudget DSS Satellite		Estimated Linkbudget DVB Satellite	
<b>DOWN LINK</b>		<b>DOWN LINK</b>		<b>DOWN LINK</b>	
EIRP	46.00 dBW	EIRP	54.00 dBW	EIRP	48.00 dBW
Free Space Loss	205.91 dB	Free Space Loss	205.78 dB	Free Space Loss	205.36 dB
Rain Loss	0.00 dB	Rain Loss	0.00 dB	Rain Loss	0.00 dB
Atmospheric Loss	0.21 dB	Atmospheric Loss	0.13 dB	Atmospheric Loss	0.12 dB
Pointing Loss	0.30 dB	Pointing Loss	0.30 dB	Pointing Loss	0.30 dB
Polarization Loss	0.23 dB	Polarization Loss	0.23 dB	Polarization Loss	0.23 dB
G/T (FOM)	21.07 dB/K	G/T (FOM)	12.22 dB/K	G/T (FOM)	13.63 dB/K
Boltz	228.60 dBW/Hz	Boltz	228.60 dBW/Hz	Boltz	228.60 dBW/Hz
C/N0	89.02 dB-Hz	C/N0	88.38 dB-Hz	C/N0	84.22 dB-Hz
Gr of antenna	39.54 dB	Gr of antenna	33.19 dB	Gr of antenna	33.19 dB
LNB gain	62.00 dB	LNB gain	56.00 dB	LNB gain	56.00 dB
Tsys at LNB out	106193065.00	Tsys at LNB out	26678414.00	Tsys at LNB out	26678414.00
C	-29.41 dBm	C	-33.25 dBm	C	-39.01 dBm
No	-118.33 dBm	No	-132.62 dBm	No	-123.04 dBm
Data Rate (Mbps)	2.36E+07	Data Rate (Mbps)	2.36E+07	Data Rate (Mbps)	2.36E+07
Data Rate dB-bps	73.73 dB-Mbps	Data Rate dB-bps	73.73 dB-Mbps	Data Rate dB-bps	73.73 dB-Mbps
Achieved Eb/N0	15.29 dB	Achieved Eb/N0	14.65 dB	Achieved Eb/N0	10.49 dB
Required Eb/N0	6.50 dB	Required Eb/N0	6.50 dB	Required Eb/N0	6.50 dB
Margin	8.79 dB	Margin	8.15 dB	Margin	3.99 dB

Table 2. Estimated Clear Sky Link Budgets

The estimated link budgets provided in table 2 were computed using the Excel and STK software applications. Calculation of system temperature and gain values are based on manufacture rated noise figures and low noise amplifier gains. The margins represent the expected robustness of the link in terms of reception quality. For example, the carrier-to-noise ratio for the SBS-6 system is at 89.02 dB/Hz. This value satisfies the performance criteria (i.e. above 75 dB/Hz C/No ratio), which stipulates a minimum carrier-to-noise power value for expected link closure. A value significantly less, such as 60 dB/Hz would suggest a degraded link and would surely result in less than satisfactory reception at the receive end.

Calculation of atmospheric losses were made using LT Stephen Scotty's USA Rain Model Excel Spread Sheets [Ref. 7]. The estimated carrier-to-noise ratios provided above are to be compared with calculated values computed from data obtained using the LabVIEW instrumentation process described in Chapter IV. The results are addressed in Chapter V. Tables 3, 4, 5, and 6 below display the Excel spreadsheets which compute estimated atmospheric and rain losses for all three systems. Table 3 is the spreadsheet for calculating atmospheric losses and Tables 4, 5, and 6, are the spreadsheets for losses attributed to rain. Both use the USA Rain Model for input parameters.

At certain wavelengths, signals are weakened by absorption bands resulting from atmospheric components (like water vapor and oxygen) [Ref. 5]. At the Ku-band, the losses imparted on the three systems being tested at NPS are computed using the Excel spreadsheet in Table 3.

SBS-6						
			FREQUENCY	12.2		
DRY AIR	0.007507	dB/Km	WATER VAPOR DENSITY	15	G/CUBIC METER	
WATER VAPOR	0.025704	dB/Km	HW0	1.6		
			ANGLE	24.71	0.431271	
WATER HEIGHT	1.646028	km				
ATTENUATION	0.208969		This is the atmospheric losses in the SBS-6 transmission			
Echostar DVB						
			FREQUENCY	12.2		
DRY AIR	0.007507	dB/Km	WATER VAPOR DENSITY	15	G/CUBIC METER	
WATER VAPOR	0.025704	dB/Km	HW0	1.6		
			ANGLE	47.43	0.82781	
WATER HEIGHT	1.646028	km				
ATTENUATION	0.118615		This is the atmospheric losses in the DVB transmission			
DSS Atmospheric Losses						
			FREQUENCY	12.2		
DRY AIR	0.007507	dB/Km	WATER VAPOR DENSITY	15	G/CUBIC METER	
WATER VAPOR	0.025704	dB/Km	HW0	1.6		
			ANGLE	42.18	0.73618	
WATER HEIGHT	1.646028	km				
ATTENUATION	0.130096		This is the attenuation loss in the DSS transmission			

Table 3. Atmospheric losses of the SBS-6, Echostar DVB, and DSS Transmissions

The critical element in determining the atmospheric loss for a given system is the combination of variable inputs such as the water vapor density, dry air temperature, water vapor content, water height, and elevation look angle. The values used in this table are taken from the USA Rain Model with the exception of the elevation look angles which are calculated in Appendix A.

Rain is a significant loss element below 60 GHz. The attenuation can vary with different types of rain [Ref. 5]. Rain losses for each of the three systems comprising the NPS Testbed based on a 99% availability link closure rate are presented in tables 4, 5, and 6. The rain region F from the USA model was selected for the general Monterey, California geographical area. This equates to a rain rate of 19 mm per hour at a station height of approximately .2 kilometers above sea level. The respective values are .207 dB for the DSS system, .304 dB for the SBS-6 system, and .189 dB for the Echostar DVB

system. These values are presented here for reference only. The link budgets in table 2 are for clear sky conditions.

This Spread Sheet is the USA model. Enter only the values labeled user input. Refer to notes.						
DSS						
USER INPUT	NOTE 1	F	Freq in GHz	12.2		
USER INPUT	NOTE 2	l0	Satellite Longitude	101 w	1.762783 r	42164.2
USER INPUT	NOTE 2	l	Station Longitude	121.8333 w	2.126392 LONG C	W
USER INPUT	NOTE 2	Ls	Station Latitude	36.6 N	0.638791	
COMPUTED		θ	Elevation angle	42.18878	0.736333	
COMPUTED		Hr	Freezing Height during rain	3.98		
USER INPUT	NOTE 2	Hs	Station Height	0.2		
COMPUTED		Ls	Slant Path Length	5.628666		
COMPUTED		Lg	Horizontal Projection	4.1704		
USER INPUT	NOTE 3	R	Rain Rate mm/hr	19		
COMPUTED		a	Freq-dep coefficient a	0.017917		
COMPUTED		b	Freq-dep coefficient b	1.160357		
COMPUTED		aR <sup>b</sup> /b	specific attenuation (dB/km)	0.546863		
COMPUTED		rh.01	Horizontal path adjustment	1.044905		
COMPUTED		ς	angle comparator	0.71453		
COMPUTED		Lr	adjusted path length	5.628666		
COMPUTED		r√0.01	Verticle Reduction Factor	1.074801		
COMPUTED		Le	Effective path length	6.049579		
COMPUTED		A0.01	Attenuation exceeded for .01%	3.302242		
USER INPUT	NOTE 4	P	Other percentage	1		
COMPUTED		z		-0.003		
COMPUTED	NOTE 5	Ap	attenuation for other percentages	0.207168		
NOTE 1	Enter the frequency in GHz in cell E2					
NOTE 2	For this program to work accurately, you must know the station lat and long and the satellite long. Enter degrees in cells E3-E6. You must also specify E or W or N or S in cells F3-F6.					
NOTE 3	Refer to ITUR Rec 837 map for rain region and the cross reference with rain rate table for appropriate rain intensity. Enter value in cell E22.					
NOTE 4	Enter the percentage of year that you want in cell E22.					
NOTE 5	This is your answer.					
	This is the amount of rain margin that your link must have to close your link for the percentage of the year that you want.					

Table 4. Rain Loss for the DSS System

This Spread Sheet is the USA model. Enter only the values labeled user input. Refer to notes.						
SBS6						
<b>USER INPUT</b>	NOTE 1	F	Freq in GHz	12.2		
<b>USER INPUT</b>	NOTE 2	l0	Satellite Longitude	74 w	1.291544 r	42164.2
<b>USER INPUT</b>	NOTE 2	l	Station Longitude	121.8333 w	2.126392 LONGC	W
<b>USER INPUT</b>	NOTE 2	Ls	Station Latitude	36.6 N	0.638791	
COMPUTED		θ	Elevation angle	24.71887	0.431426	
COMPUTED		Hr	Freezing Hght during ran	3.98		
<b>USER INPUT</b>	NOTE 2	Hs	Station Hght	0.2		
COMPUTED		Ls	Sant Path Length	9.039467		
COMPUTED		Lg	Horizontal Projection	8.211186		
<b>USER INPUT</b>	NOTE 3	R	Rain Rate mm/hr	19		
COMPUTED		a	Freq dep coefficient a	0.017917		
COMPUTED		b	Freq dep coefficient b	1.160367		
COMPUTED		aP/b	specific attenuation (dB/km)	0.546863		
COMPUTED		rh01	Horizontal path adjustmet	0.915097		
COMPUTED		ς	angle comparator	0.466092		
COMPUTED		Lr	adjusted path length	8.271988		
COMPUTED		r001	Verticle Reduction Factor	1.004823		
COMPUTED		Le	Effective path length	8.311887		
COMPUTED		A001	Attenuation exceeded for .01%	4.537152		
<b>USER INPUT</b>	NOTE 4	P	Other percentage	1		
COMPUTED		z		-0.003		
COMPUTED	NOTE 5	Ap	attenuation for other percentages	0.304012		
NOTE 1	Enter the frequency in GHz in cell E2					
NOTE 2	For this program to work accurately, you must know the station lat and long and the satellite long Enter degrees in cells E3-E6. You must also specify E or W or N or S in cells F3-F6					
NOTE 3	Refer to ITU-R Rec 837 map for rain region and the cross reference with rain rate table for appropriate rain intensity. Enter value in cell E2					
NOTE 4	Enter the percentage of year that you want in cell E2					
NOTE 5	This is your answer.					
	This is the amount of rain margin that your link must have to close your link for the percentage of the year that you want.					

Table 5. Rain Loss for the SBS-6 GBS CONUS System

This Spread Sheet is the USA model. Enter only the values labeled user input. Refer to notes.						
DVB						
<b>USER INPUT</b>	NOTE 1	F	Freq in GHz	12.2		
<b>USER INPUT</b>	NOTE 2	l0	Satellite Longitude	119 w	2.076942 r	42164.2
<b>USER INPUT</b>	NOTE 2	l	Station Longitude	121.8333 w	2.126392 LONG COW	
<b>USER INPUT</b>	NOTE 2	Ls	Station Latitude	36.6 N	0.638791	
COMPUTED		θ	Elevation angle	47.43796	0.827949	
COMPUTED		Hfr	Freezing Height during rain	3.98		
<b>USER INPUT</b>	NOTE 2	Hs	Station Height	0.2		
COMPUTED		Ls	Slant Path Length	5.132067		
COMPUTED		Lg	Horizontal Projection	3.471269		
<b>USER INPUT</b>	NOTE 3	R	Rain Rate mm/hr	19		
COMPUTED		a	Freq-dep coefficient a	0.017917		
COMPUTED		b	Freq-dep coefficient b	1.160357		
COMPUTED		aRp <sup>a</sup> /b	specific attenuation (dB/km)	0.545863		
COMPUTED		rh.01	Horizontal path adustment	1.077859		
COMPUTED		ς	angle comparitor	0.790511		
COMPUTED		Lr	adjusted path length	5.132067		
COMPUTED		rv0.01	Verticle Reduction Factor	1.095316		
COMPUTED		Le	Effective path length	5.621238		
COMPUTED		A0.01	Attenuation exceeded for .01%	3.068426		
<b>USER INPUT</b>	NOTE 4	P	Other percentage	1		
COMPUTED		z		-0.003		
COMPUTED	NOTE 5	Ap	attenuation for other percentages	0.189592		
NOTE 1	Enter the frequency in GHz in cell E2.					
NOTE 2	For this program to work accurately, you must know the station lat and long and the satellite long. Enter degrees in cells E3-E6. You must also specify E or W or N or S in cells F3-F6.					
NOTE 3	Refer to ITU-R Rec 837 map for rain region and the cross reference with rain rate table for appropriate rain intensity. Enter value in cell E22.					
NOTE 4	Enter the percentage of year that you want in cell E22.					
NOTE 5	This is your answer.					
	This is the amount of rain margin that your link must have to close your link for the percentage of the year that you want.					

Table 6. Rain Loss for the Echostar DVB System

## 2. Satellite Footprints for SBS-6, Echostar, and DSS

The figures below (Figures 4, 5, and 6), provide the reader with an aerial view of the EIRP coverage area for the three satellite systems comprising the NPS GBS Testbed. Looking at an EIRP map, one can determine the transmit satellite EIRP for a given geographical area. For example, in Figure 4 the SBS-6 EIRP for the Monterey, California area is 46 dBW. This value is used in link budget calculations for determining the carrier-to-noise power ratios for a particular geographical location assuming the location is within the satellite's footprint. EIRP maps are generally provided by the manufacture and are subject to change based on satellite orbital adjustments and satellite longevity.

a. *Satellite footprint of SBS-6*

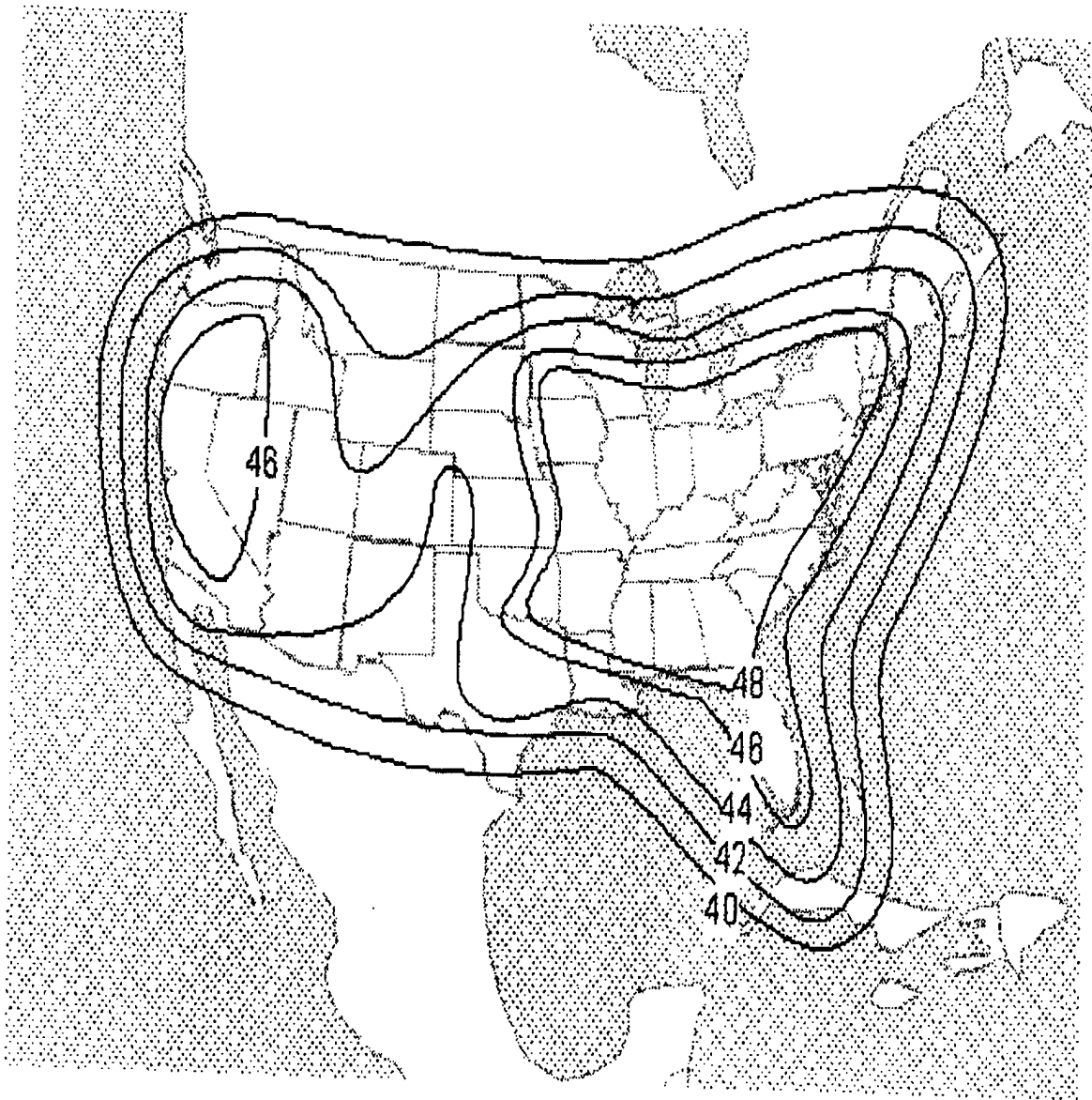
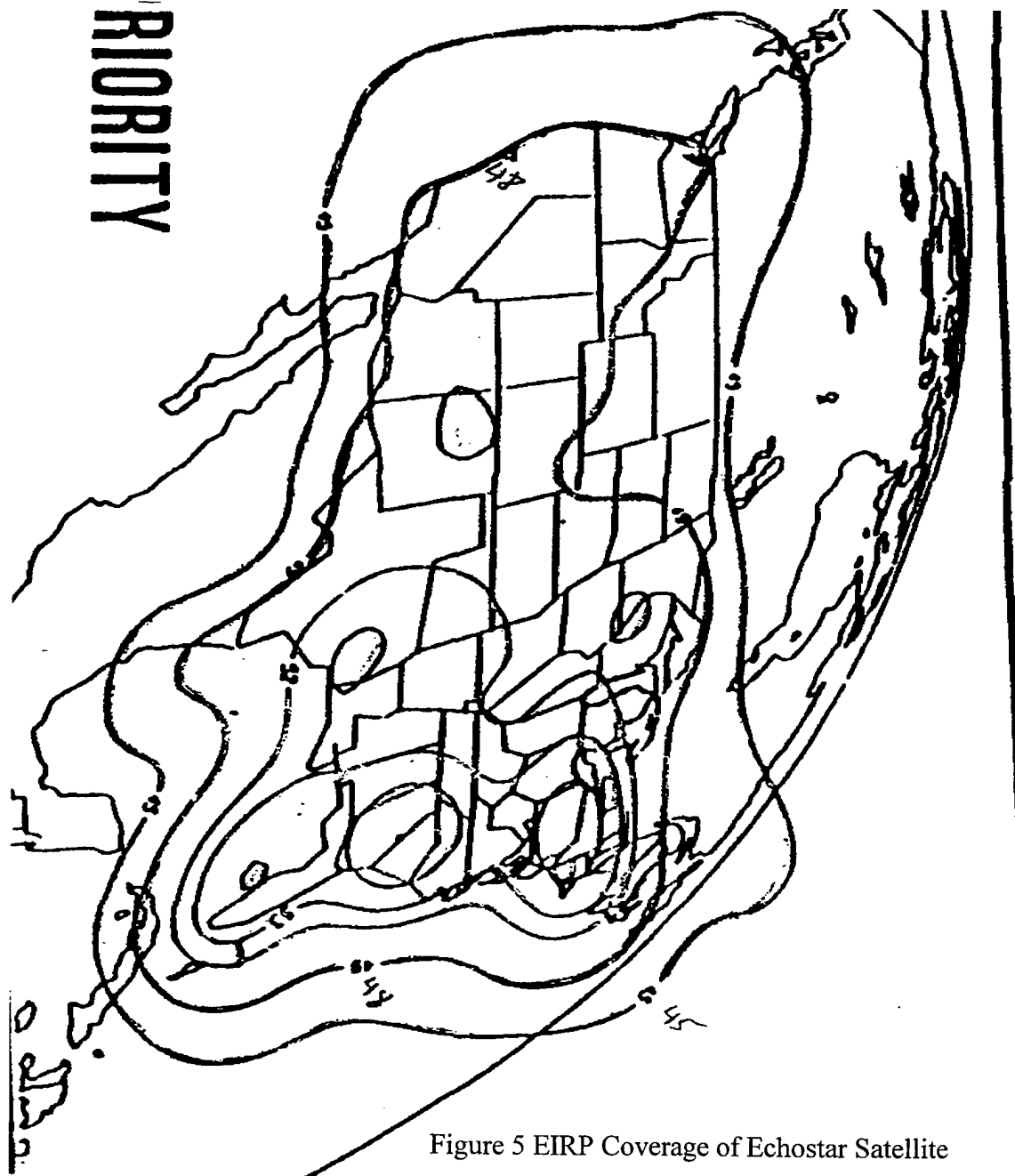
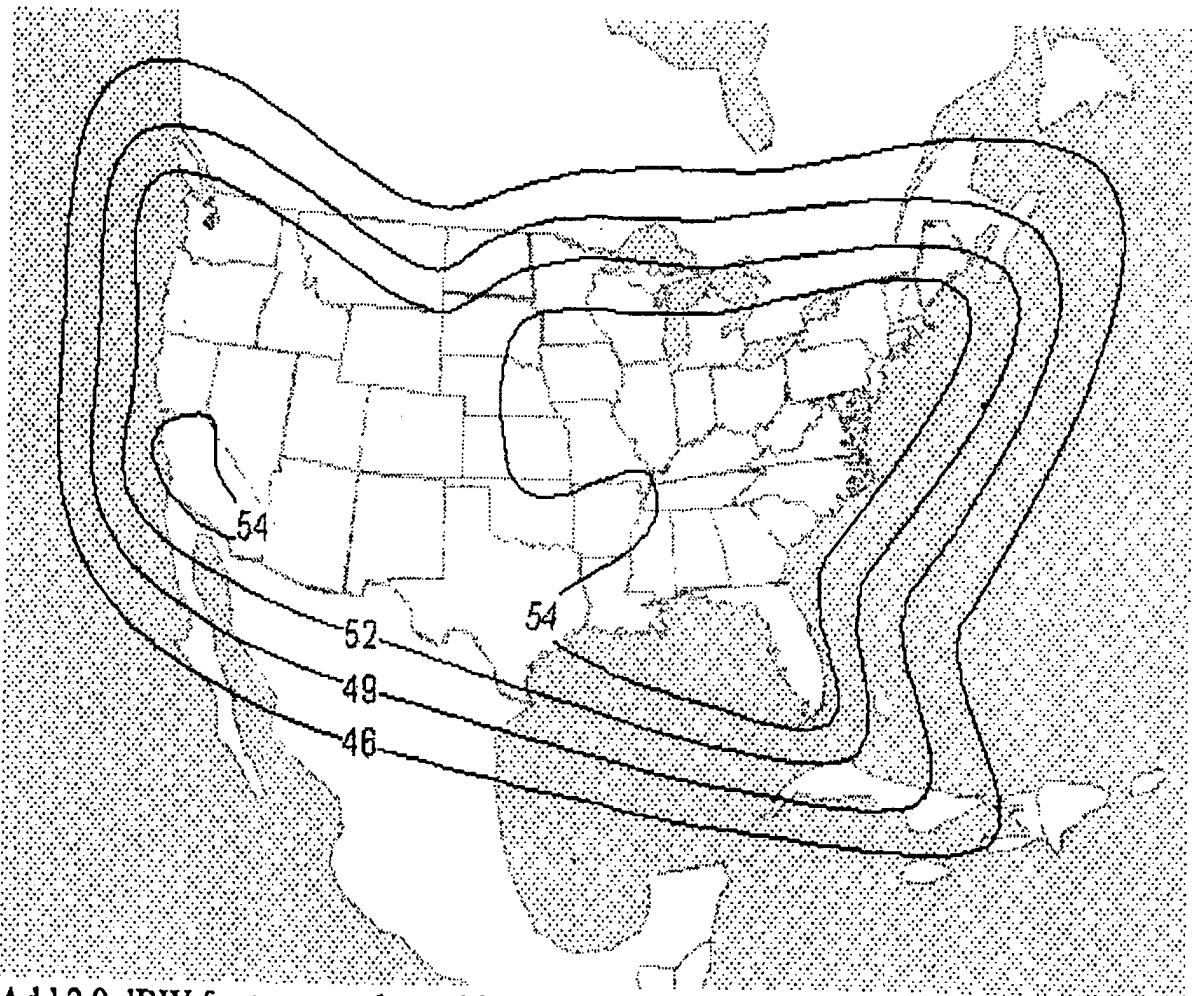

Figure 4 EIRP Coverage of SBS-6 Satellite

b. *Satellite footprint of Echostar DVB*



c. *Satellite footprint of DSS*



Add 2.9 dBW for transponders with 240 W power.

Figure 6 EIRP Coverage of DSS Satellite



### III. NPS INSTRUMENTATION TESTBED CONFIGURATION

#### A. HARDWARE

This chapter will examine the hardware and software currently installed in the NPS Testbed. It will also discuss hardware and software that will be installed for GBS research in the future.

A receive site GBS Testbed is installed in the Secure Systems Technology Laboratory (SSTL) at NPS. The purpose of the Testbed is to conduct experimental research on critical technical and functional aspects of the GBS, DVB, and DSS systems. The Testbed consists of two Ku band DSS commercial systems, one DVB Ku-band commercial system, and one system receiving the Phase I GBS Ku band CONUS broadcast. A one meter antenna is installed and is receiving the GBS CONUS broadcast (at the time of this writing, the SBS-6 satellite is at 89 degrees W). Two standard .45 meter antennas receive the DirecTV broadcast from the Hughes DBS satellites at 101 degrees W, and an additional .45 meter antenna receives the Echostar DVB broadcast at 119 degrees W. The antennas are installed on top of Root Hall, in close proximity above the SSTL laboratory. Each of the DSS commercial systems have two Integrated Receiver Decoders (IRD) and two television monitors.

The GBS system currently has two IRDs, one decoding video and the other decoding IP data. (At the time of this writing, plans are underway to install a third IRD which will support decoding of ATM protocols). The data IRD and associated C.D.I. data bridge is connected to a SPARC 20 workstation through a KG-194 encryption device and a CISCO 2514 router. The GBS configured workstation is on the SSTL secure net that supports the workstations of the NPS Global Command and Control (GCCS) installation. This net is connected to other GCCS sites and elsewhere through a 512Kbps SIPRNET secure connection. An appropriate antenna and LNB to receive the UFO K-band 20.7 GHz GBS broadcast will be installed in the future [Ref. 6]. Figure 7 below displays the rack mounted KG-194 encryption device along with an IRD and data bridge assembly. These components make up the SBS-6 GBS CONUS receive system. The secure crypto room is located on the second floor of Root Hall and is accessed by authorized user's only.

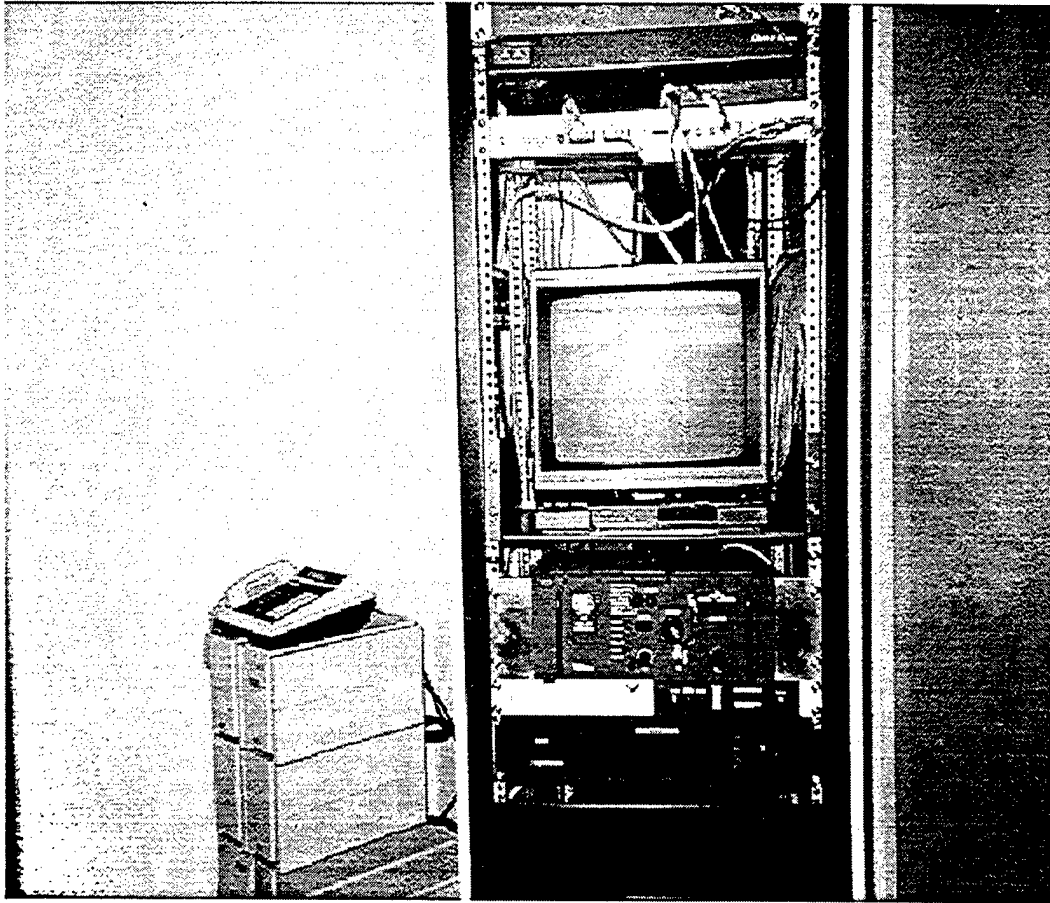

Figure 7 KG Room rack mounted equipment for GBS CONUS Testbed

The DVB Echostar system is comprised of one IRD decoding a number of video channels and a data channel. The IRD is located in the SSTL and is displayed on its own monitor. The Echostar system utilizes the DVB variable data rate transmission technique. The variable data rate allows for transmission to occur at ranges from 1 Mbps to 50 Mbps depending on what type of information products are being disseminated and the bandwidth and power of the satellite transponder. The purpose of installing a DVB system at the NPS Testbed is to study and compare the performance of DVB to the DSS and GBS SBS-6 satellite transmissions.

Test monitoring equipment is installed to record received carrier power of each of the active transponders and their background noise levels. This equipment consists of an HP 8568B digital spectrum analyzer connected via a GPIB/HPIB interface to a PC Pentium equipped with LabVIEW and Matlab software for recording, analyzing, and displaying data from test instruments. The interface is made through the use of a PCMCIA-GPIB plug and play card designed for PC applications. Additionally, a Fireberd 6000 bit error analyzer will be interfaced with the PC Pentium in the near future. It will also use the PCMCIA-GPIB connection to conduct research in bit error detection and analysis.

# Naval Postgraduate School CONUS Testbed GBS Receiver Suite

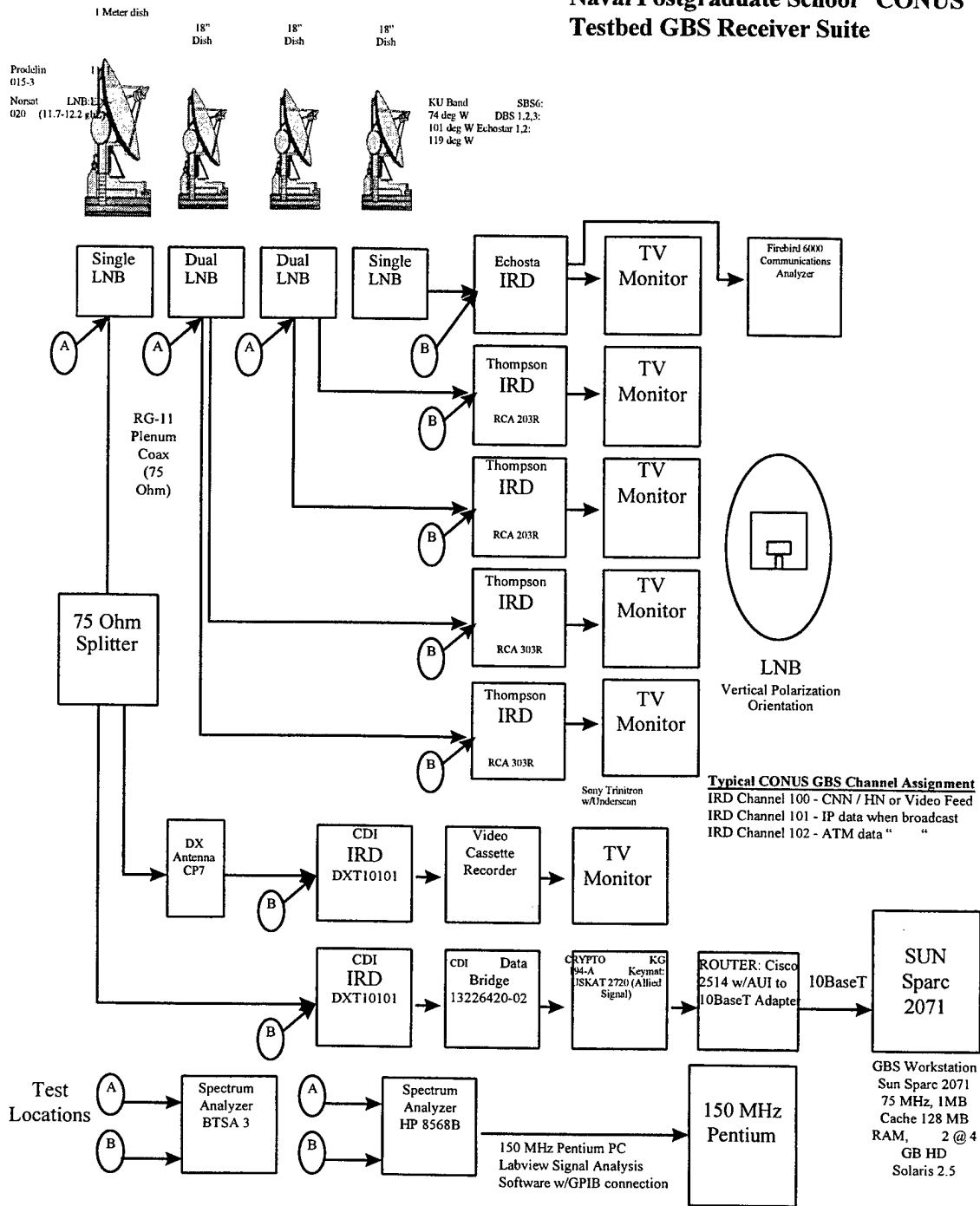

Figure 8 GBS CONUS Testbed Receive Suite

Figure 8, represents the physical layout of the NPS Testbed suite. The four receive antennas are located on the roof of Root Hall. RG-11 coaxial cable is routed from the receive antenna(s) low noise block(s) (LNBS) down through the roof into various rooms on the second floor of Root Hall. RG-11 coaxial cable is used in all three systems because of its low line loss. The coax cable from the 1 meter dish (the GBS SBS-6 receive antenna) is routed to the secure crypto room which houses the first IRD and a stand alone data bridge, CISCO router, TV monitor, and KG-194 encryption/decryption device. A 75 Ohm splitter device is installed in order to separate the incoming data signal from the video content. The video signal is forwarded to its own IRD located in the Secure Systems Technology Lab (SSTL). The data signal is sent to its respective IRD followed by the data bridge (buffers incoming data while awaiting decryption). The data signal is then decrypted via the KG-194 and subsequently routed to the SPARC 20 terminal located in the SSTL down the hall from the crypto room. The remaining systems (.45 meter (m) receive antennas for the DVB and DSS signals) are connected via RG-11 coaxial cable to their IRDs which are also located in the SSTL. Each system is fitted with a TV monitor for viewing video content.

The SSTL is equipped with a 150 MHz PC which runs the LabVIEW software application fundamental to the instrumentation process described in this thesis. Additionally, an Hewlett-Packard HP8568B spectrum analyzer and a Blonder-Tonge BTSA portable spectrum analyzer also are maintained in the SSTL. These two instruments are essential for the data acquisition of the signal received in each of the three satellite systems. The HP8568B spectrum analyzer is coupled with the PC via a PMCIA-GPIB interface for instrument control and data acquisition.

The remainder of this chapter addresses individual hardware components comprising the NPS GBS Testbed. Each hardware device is described briefly with the intent of familiarizing the reader with the basics of each component. These components consist of the IRDs, receive antennas for DVB, DSS, and GBS, the Fireberd 6000 bit error analyzer, Blonder-Tonge spectrum analyzer (BTSA), HP 8568B spectrum analyzer, and a PC Pentium computer.

### **1. Integrated Receiver Decoder (IRD) / Low Noise Block (LNB)**

The LNB consists of a low noise amplifier and downconverter contained in one unit. The LNB is designed to receive the incoming signal which is first amplified by the

low noise block amplifier mounted on the receive antenna. It amplifies the signal to an acceptable level and down converts it from 11.7-12.2 GHz to 950-1450 MHz (L-band). The L-band signal is sent via the RG-11 transmission line to the IRD for demodulation followed by decoding via the decoder. Figure 9 shows a typical set-up with an LNB and IRD.

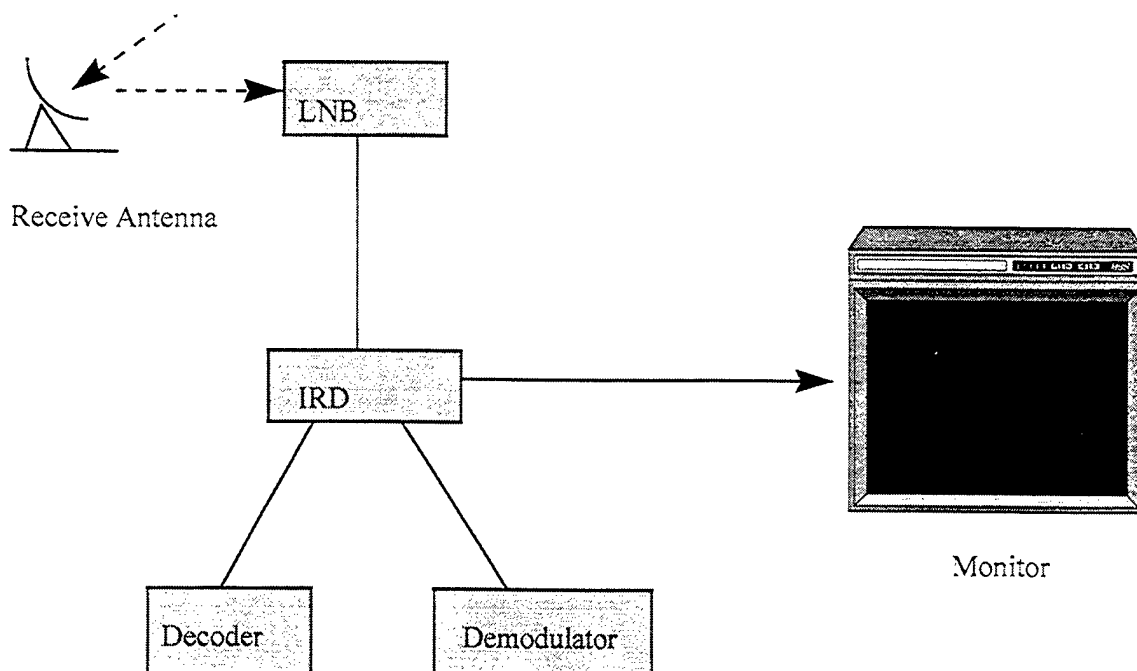

Figure 9 Typical Set-up with Receive Antenna, LNB and IRD

## 2. Receive Antennas for GBS, DVB, and DSS

The three satellite receive systems addressed in this thesis are fitted with their own receive antennas. The antennas themselves are located on a mounted plywood deck on top of Root Hall on the NPS campus. The SBS-6 GBS system uses a 1 m commercial type reflecting dish with base plate and pole for mounting on a level surface. The LNB (feed horn), which receives the reflected signal off the 1 m dish is a NorSat KU LNB with a .83 dB noise figure and 62 dB of gain.

Like the SBS-6 receive antenna, both the DSS and DVB systems are equipped with similar receive antennas with the exception of aperture size. Both the DSS and DVB receive antennas are .45 m in diameter and likewise are connected to their respective

IRDs using RG-11 coaxial cable. Noise figures for the DSS and DVB LNBS are rated at 1.4 dB and 1.28 dB respectively. Gains are  $56 \text{ dB} \pm 6 \text{ dB}$ . Figure 10 is a picture of the four satellite receive antennas on top of Root Hall that make up the NPS GBS Testbed. The 1 m GBS CONUS receive antenna is pictured to the right, while the two DSS RCA receive antennas are aligned in parallel towards the left. The Echostar DVB receive antenna is located in the back left of the picture.

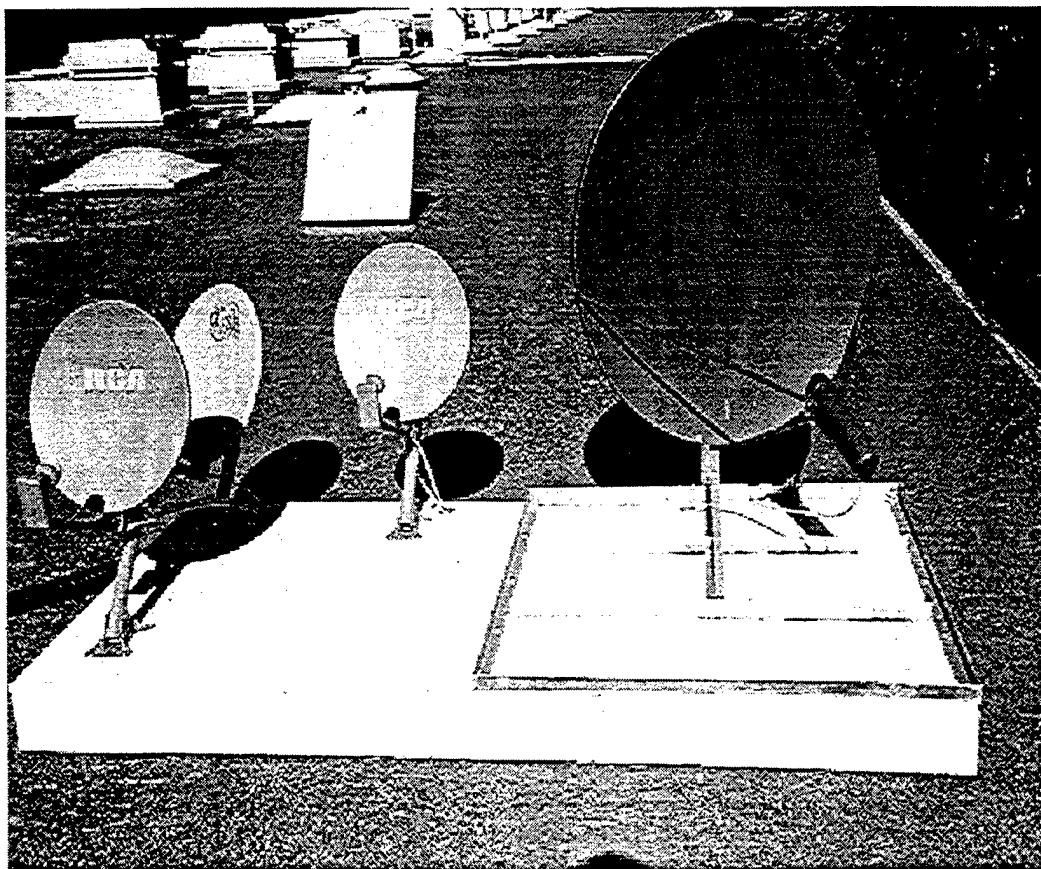

Figure 10 Receive Antennas on top of Root Hall

### 3. Fireberd 6000 Bit Error Analyzer

In support of bit error identification and study, a Fireberd 6000 bit error analyzer is to be installed permanently in the NPS instrumentation Testbed. The Fireberd 6000 is a multifunction communications analyzer that can terminate a variety of communications circuits and analyze the quality of the circuit under test. Locations in which the Fireberd can be used include earth receive stations such as the NPS Testbed receive site. The location where access to the circuit can be gained determines the interface that is installed in the Fireberd 6000. The interface provides the physical connection to the circuit under test [Ref. 7]. The interface also provides proper termination, signal conditioning, framing, and timing. An optional interface is inserted in the Fireberd interface slot and then either controlled locally or remotely. This allows the user to operate the Fireberd locally by using the front panel switches and controls, or remotely by using a suitable remote controller. In the NPS instrumentation Testbed, the Fireberd upon installation, will be controlled remotely by a PC using National Instrument's LabVIEW software.

The Fireberd uses digital interfaces to test T1, CCITT, DDS, and synchronous/asynchronous circuits and equipment. In addition to its versatility, the Fireberd provides for combining bit error rate testing with performance, signal, and timing analysis. Future work will address bit error rate content, burst frequency, atmospheric affects, and protocol effects on bit errors across all three systems; the SBS-6, DSS, and DVB receive signals. Presently, the Fireberd is being utilized for Bit Error Rate (BER) observations on the Echostar DVB system. Coordination with the Echostar uplink site was required since a bit test sequence has to be inserted into the transmitted signal. This predetermined sequence provides the necessary baseline for determining if bit errors have occurred at the end of the receiver. The author includes this brief description of the Fireberd 6000 as it will be remotely operated in the same manner as the HP8568B spectrum analyzer using LabVIEW software. This remote controlling and reading of instruments such as the HP8568B spectrum analyzer is covered in Chapter IV. Figure 11 is front panel view of the Fireberd 6000 Bit Analyzer.

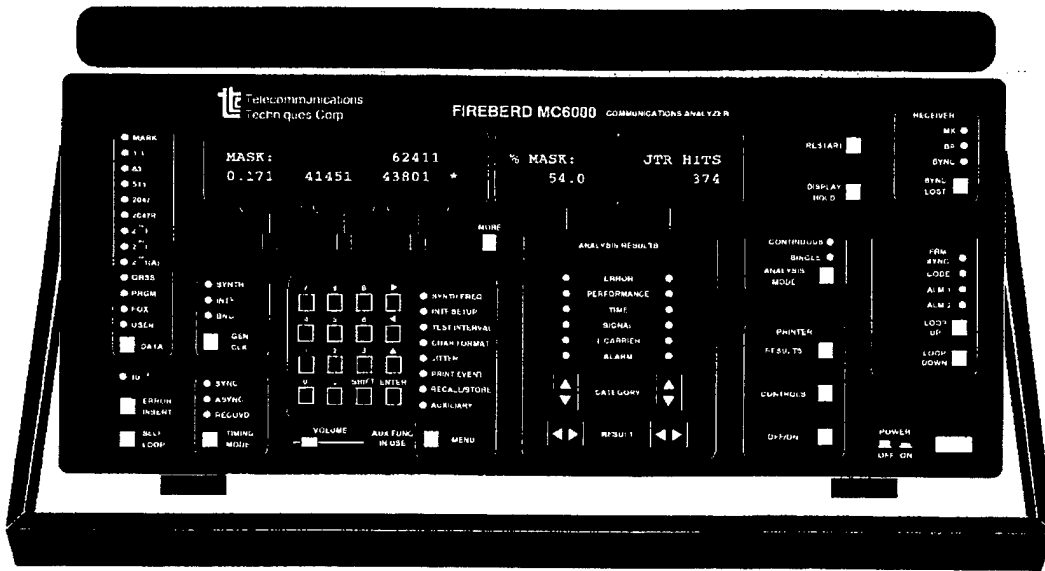

Figure 11 Fireberd 6000 Bit Error Rate Test Equipment

#### 4. BTSA Spectrum Analyzer

The BTSA-3 Blonder-Tongue multifunction satellite analyzer is designed to support installation of satellite TV distribution networks as well as professional VSAT systems and ground stations. The BTSA-3 satellite analyzer has proved crucial to the installation of the NPS Testbed. This device is used for locating the proper satellite and adjusting the pointing and polarization of the receive antennas for the strongest signal possible. The BTSA-3, being battery operated and approximately the size of a small radio, is both lightweight and easy to use.

#### 5. HP 8568B Spectrum Analyzer

The HP8568B is a high performance, 100 Hz to 1.5 GHz spectrum analyzer for instrumentation and test use. The frequency stability of the HP8568B allows for measurements down to 10 Hz of bandwidth. At this narrow bandwidth, the spectrum analyzer yields noise levels as low as -135 dBm [Ref. 8]. The HP8568B was chosen for its exceptional ability to allow for very accurate measurements of small signals in the presence of large ones. Multiple traces can be displayed to measure and conduct real-time surveillance over a wide frequency range. As mentioned earlier, the HP8568B allows for

this real-time surveillance over the L-band intermediate frequency range of 950 to 1450 MHz which is ideal for all three satellite signals addressed in this writing.

The most critical element in the instrumentation Testbed is the HP 8568B spectrum analyzer. This device offers superb accuracy over a wide range of precision measurements. In addition, this system can also be used for determining line loss figure measurements taken directly after the antenna LNB and at the cable termination points. These line loss figures are necessary for accurate received-signal power measurements and subsequent link budget comparisons.

A potential user of this instrument should realize that it does not allow DC voltage at its signal input socket—as with the BTSA-3 spectrum analyzer. To satisfy this dilemma, a 75 Ohm combination insertion block/blocking capacitor (DX Antenna, Model CP-7) and adjustable DC power supply (Hewlett-Packard, Model 6215A) are used to power the LNB's during measurement periods. These devices enable insertion of requisite LNB DC power directly into the RG-11 coaxial cable, and simultaneously block the DC current from flowing into the HP 8568B analyzer. This device is rated at an average insertion loss of approximately 0.5 dB. Figure 12 is the front panel of the HP 8568B spectrum analyzer.

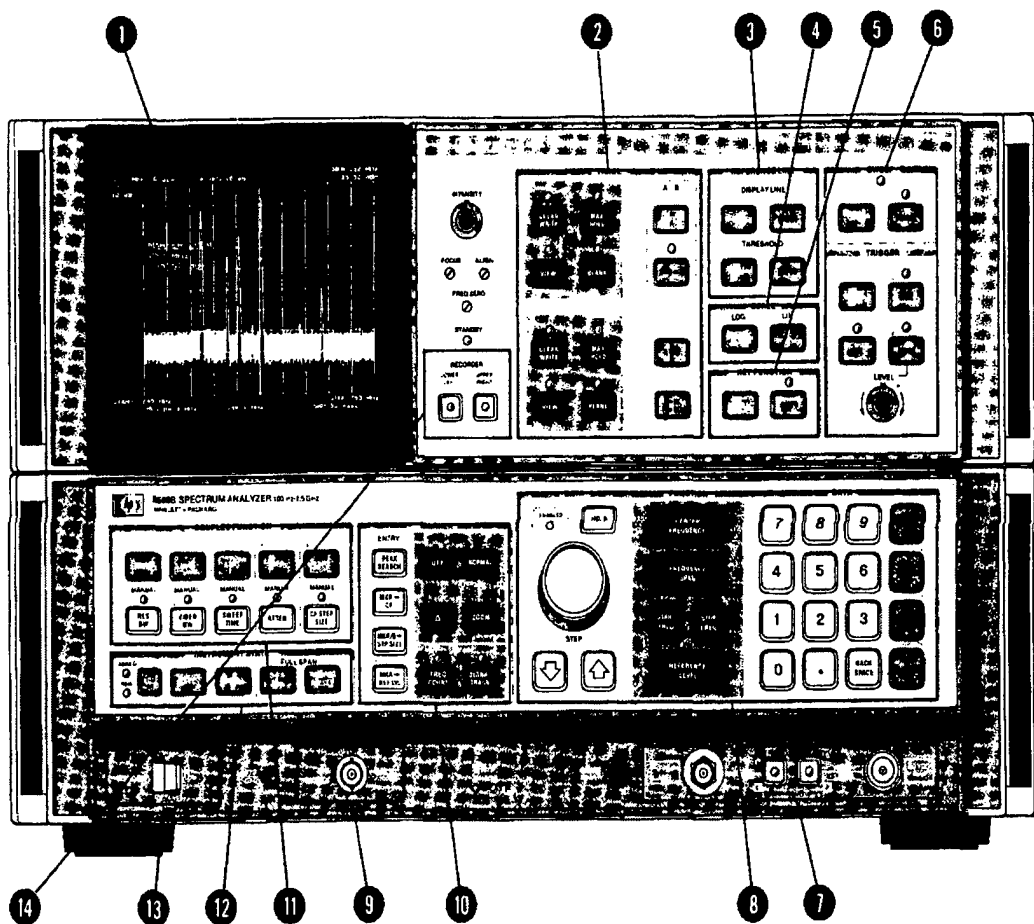

Figure 12 HP 8568B Spectrum Analyzer

Currently, the NPS instrumentation Testbed is using an HP8568B spectrum analyzer connected to a PC for remote control and data acquisition. To decrease the time required for conducting signal power measurements and to improve data acquisition, a PC-based "Virtual Instrumentation" or VI package developed by National Instruments is being used (National Instruments LabVIEW Software). This software enables a PC to remotely control the spectrum analyzer as well as collect, mathematically manipulate, and store measurement data. The interface between the spectrum analyzer and the PC is the HPIB or GPIB standard interface. The PC is equipped with a PCMCIA-GPIB adapter port to receive the National Instrument's HPIB/GPIB interface card.

## **6. Personal Computer**

A 166 MHz IBM type personal computer is utilized for controlling and data collection of/from the HP8568B spectrum analyzer. The computer maintains a 1.6 Giga-byte hard-drive with 16 Megabytes of RAM. To support extensive data collection (upwards of 20 Mega-byte files), an external 100 Mega-byte Zip drive is being used. The computer is loaded with National Instrument's LabVIEW software and Matrix Laboratory (Matlab) Statistical Analysis software. The Matlab software is being used for mathematical data manipulation, graphical interpretation, and statistical analysis of the satellite receive signals pre-recorded using the LabVIEW software. Upon completion of a test run, the data is saved onto the Zip drive and then loaded into Matlab for manipulation and analysis. Specific manipulation and statistical analysis programs (.m files in Matlab), are described in Chapter IV.

### **B. SOFTWARE**

As revealed earlier, two separate software packages, National Instrument's LabVIEW and Matlab Statistical Analysis Tool, are being used in the NPS instrumentation Testbed. This section briefly explains the advantages of using both LabVIEW and Matlab for measurement, analysis, and interpretation.

#### **1. National Instrument's LabVIEW Software Version 4.0**

LabVIEW software is a program development application, much like C or BASIC. However, LabVIEW is different from those applications in that other programming systems use text-based languages to create lines of code, while LabVIEW uses a graphical programming language, called G, to create programs in block diagram form. LabVIEW, like C or BASIC, is a general-purpose programming system with extensive libraries of functions for any programming task. LabVIEW includes libraries for data acquisition, GPIB and serial instrument control, data analysis, data presentation, and data storage [Ref. 9].

In the NPS instrumentation Testbed, LabVIEW is used for data acquisition, GPIB instrument control, data analysis, and data storage. Data manipulation and graphical presentation is accomplished through the use of Matlab software which will be addressed later. Use of LabVIEW eases significantly the time required for data accumulation, analysis, and storage. It has facilitated a "hands off" approach to data collection which

has resulted in parallel productivity in other areas of the instrumentation Testbed measurement process. LabVIEW uses a technique referred to as “Virtual Instrumentation” which is covered in detail in Chapter IV.

## **2. Matlab Statistical Analysis Software Version 4.2**

Matlab is both an environment and a programming language that allows the user to build reusable “tools” [Ref. 10]. Using Matlab, one can create special functions and programs (known as M or .m files) in Matlab code. Matlab allows the user to express algorithms in a few dozen lines, to compute the solution with great accuracy in a few seconds on a PC, and to readily manipulate color three-dimensional displays of the results. The results provided in this writing are arrived at using Matlab code—generated by the author. Using Matlab provides the capability to manipulate and process large data sets with relative ease and superb accuracy in results.



## IV. METHODOLOGY

This chapter introduces and then discusses the methodology employed in conducting the instrumentation of the NPS GBS Testbed. It covers both the use of National Instruments LabVIEW and Math Work's Inc. Matlab software. This chapter explains the use of these software packages from the perspective of system requirements, analysis, design issues, design specifications, and results obtained. A thorough explanation of the virtual instrument(s) or VIs that were used in the instrumentation of the NPS GBS Testbed is provided. In addition, descriptions of Matlab .m files written for this application are provided for user clarification.

### A. LABVIEW® SOFTWARE

Recall that National Instrument's LabVIEW software is an application that allows for remote controlling of an instrumentation device while simultaneously accumulating data from it. In addition, the software comes equipped with extensive analysis functions which were used for data interpretation in conjunction with Matlab software. The basic principle behind LabVIEW is the concept of virtual instrumentation. In LabVIEW, using the G programming language, the user develops virtual instruments (or VIs) which are actual program code that can be manipulated in a graphical user interface (GUI) environment [Ref. 9]. The software is heavily populated with pre-existing VIs which can be modified to suit one's particular instrumentation needs. In the NPS Testbed environment, the need for an interface VI with the HP 8568B and the Fireberd 6000 bit error analyzer were identified early in the project. Through use of existing VIs, a rapid prototype was put together very early in the stages of installation of the Testbed. At the time of this writing there exists a fully developed VI for interface with the HP 8568B spectrum analyzer. A VI is being developed for interfacing with the Fireberd 6000 which will serve to control that instrument and collect data on bit error content in a real-time mode.

The VI designed for the HP 8568B took considerable time and effort. Should the need arise for future VI development, the author strongly recommends using existing VIs as much as possible. In the case of the HP 8568B analyzer this was not an option. Consequently, the VI was developed from scratch, module by module, until completion.

## 1. Virtual Instrumentation

The traditional instrument is self-contained, with signal input/output capabilities and fixed user interface features such as knobs, switches, and other features. Inside the instrument specialized circuitry, including A/D converters, signal conditioning, microprocessors, memory, and an internal bus accept real-time signals, analyze them, and present results to the user. Typically, the vendor defines all the instrument functionality—the user cannot change it. Virtual instruments leverage off the open architecture of industry-standard computers to provide the processing, memory, and display capabilities; off-the-shelf, inexpensive DAQ boards and GPIB interface boards plugged into an open, standardized bus provide the instrumentation “front end” capabilities. Because of the open architecture of PCs and workstations, the functionality of virtual instruments is user defined, and thus scaleable and extensible. The fundamental concepts of virtual instruments directly translate to bottom-line benefits for the user. The user, not the vendor, defines the ultimate functionality of the instrument. Virtual instruments leverage off the computer engine to deliver fast return on technology with life cycles of one to two years [Ref. 9].

## 2. Virtual Instrument Design for Data Accumulation

### *a. Requirements*

The first step in designing a VI for the accumulation of data from the H8568B spectrum analyzer was determining and subsequently defining the VI requirements. The requirements are the following:

- The VI must acknowledge the HP 8568B spectrum analyzer through the GPIB interface.
- The VI need not be able to control the HP 8568B entirely. User adjustment of the front panel on the spectrum analyzer was sufficient for envisioned data collection purposes. The only control feature of the VI required is its ability to trigger the instrument device for requested data.
- The VI will display the frequency and amplitude of the incoming satellite receive signal in two ways: 1) A 2 x 1001 matrix (Array containing 1001 samples; two rows—one frequency, the other, amplitude) with resulting

frequency in Hz and amplitude values as pre-set in significance of digits by the user. 2) A graphical depiction of the incoming satellite receive signal with the X-axis displaying frequency and Y-axis, the amplitude in dB.

- The VI will be designed such that the user can input the file storage path for resultant data storage.
- The VI will be designed to run either once or at periodic intervals for user selected data collection periods.
- The VI will be designed with time and data in mind such that at each run of the program, the time and date will be annotated in the data output file and specific file comments can be input to stored data file.
- The VI will be designed such that any change made to the front panel settings of the HP 8568B analyzer will be reflected on the VI front panel as viewed by the user in a GUI environment.
- The VI will be very similar in appearance to the front panel of the HP 8568B.
- The VI will be able to run with or without data output being saved to a file.
- The VI will have the capacity to modify data storage formats such that it will be able to export data usable by other software applications (e.g. Matlab).

These requirements were all met and are functioning in the current VI (GBSTESTBED.VI), being used in the NPS instrumentation Testbed.

### **3. Basics of Virtual Instrumentation using LabVIEW**

This section discusses basic features that the user needs to be familiar with in order to create or use VIs, including information about the front panel and block diagram windows, LabVIEW palettes and menus. It also discusses basic tasks the user needs to learn such as how to create objects, change tools, get help, and how to open, run, and save VIs.

#### ***a. Front Panel and Block Diagram***

Each VI has two separate but related windows: the front panel and the block diagram. The user can switch between windows with the **Show Panel/Show Diagram** command in the **Windows** menu. Using the Tile commands, also in the

**Windows** menu, the user can position the front panel and block diagram windows side-by-side (next to each other), or up-and-down (one at the top of your screen, and one at the bottom of your screen).

If the user has multiple windows VIs open simultaneously, only one is the active VI. This is the VI whose front panel or block diagram is foremost or currently selected. All open front panels and block diagrams are listed at the bottom of the Windows menu, and the active front panel or block diagram has a check-mark beside its respective name.

The front panel is representative of the front panel on the instrument device being controlled or interfaced with the VI. Most VIs are designed such that the front panel looks as close as possible to the instrument being used. When running the VI, the user will usually execute a run from the front panel where s/he can see the VI running and producing desired results. When opening VIs from saved storage, the first screen to appear is the front panel and unless the user intends to program in LabVIEW code, the user will exercise the front panel most often when working with VIs.

On the other hand, the block diagram is where programming in LabVIEW takes place. If the user wants to make changes to existing VIs or if they wish to develop new VIs, s/he will utilize the block diagram portion of the existing or newly untitled VI to do so.

#### ***b. LabVIEW Menus***

LabVIEW uses menus extensively. The menu bar at the top of a VI window contains several pull-down menus. When the user clicks on a menu bar item, a menu appears below the bar. The pull-down menus contain items common to other applications, such as Open, Save, Copy, and Paste, and many others particular to LabVIEW. Some menus also list shortcut key combinations. The LabVIEW menu the user will use most often is the object pop-up menu. Virtually every LabVIEW object, as well as empty front panel and block diagram space, has a pop-up menu of options and commands. To access an object's pop-up menu, put the cursor on that object and click the right mouse button.

*c. Creating Objects*

The user can create objects on the front panel and block diagram by selecting them from the floating **Controls** and **Functions** palettes. For example, if the user wants to create a known object on a front panel, s/he would select it from the **Numeric** palette of the **Controls** palette, click the left mouse button, and place the object inside the front panel. As the user moves the selection arrow over an object on the palette, the name of the object will appear at the top of the palette. Typical objects are knobs, toggles, switches, buttons, and so on which can be easily selected from the **Controls** palette. When you create front panel objects, they appear with a label rectangle ready for the user to enter the name of the new object. If the user wants to give the object a name, enter the name on the keyboard. When finished entering the name, end text entry by pressing the <Enter> key on the numeric keypad. It is important to note that when an object is created on a front panel, a corresponding terminal is created on the block diagram for the VI. This terminal is used for reading data from a control or sending data to an indicator. If the user wants to see the corresponding diagram for the front panel created, select **Windows>>Show Diagram**. The block diagram contains terminals for all front panel controls and indicators.

*d. Quick Access to Controls and Functions*

If the user needs several functions from the same palette, he/she may want to keep a palette open permanently. To keep a palette open, select the push-pin in the top left corner of the palette. Once the user has pinned a window open, it has a title-bar that can be moved around easily. If the VI is then saved, the next time LabVIEW is opened, the palettes will be opened in the same locations they were last left.

*e. LabVIEW Tools*

In LabVIEW, a tool is a special operating mode of the mouse cursor. The user can use tools to perform specific functions. Many of LabVIEW's tools are contained in the floating **Tools** palette which can be accessed through the pull-down menu titled **Windows**. The user can move the tool palette anywhere, or can close it temporarily by clicking on the close box. Once closed, the tool palette can be accessed again by selecting **Windows>>Show Tools Palette**. The user can change from one tool to another by doing any of the following while in edit mode:

- Click on the tool desired in the **Tools** palette.
- Use the <Tab> key to move through the most commonly used tools in sequence.
- Press the spacebar to toggle between the **Operating** tool and **Positioning** tool when the front panel is active, and between the **Wiring** tool and **Positioning** tool when the block diagram is active.

#### *f. Saving VIs*

Five options in the File menu concern saving VIs as individual files. Select the Save option to save a new VI, choose a name for the VI, and specify its destination in the disk hierarchy. Also use this option to save changes to an existing VI in a location previously specified. If the user wants to save a VI with a new name, s/he can use **Save As...**, **Save a Copy As...**, or **Save with Options...** from the file menu.

When selecting the **Save As...** option, LabVIEW saves a copy of the VI in memory to disk with the name specified. After the save is finished, the VI in memory points to the new version. In addition, all callers to the old VI that are in memory now refer to the new VI. If the user enters a new name for the VI, LabVIEW does not overwrite or delete the disk version of the original VI. If the **Save A Copy As...** option is selected, LabVIEW saves a copy of the VI in memory to disk with the name specified. This does not affect the name of the VI in memory. **Save with Options...** brings up a dialog box which the user can choose to save an entire VI hierarchy to disk, optionally saving VIs without their block diagrams. This option is useful when the user is distributing VIs or is making backup copies. **NOTE:** The user cannot edit a VI after having saved it without a block diagram. Always make a copy of the original VI including its respective block diagram.

#### *g. Opening and Closing VIs*

Opening VIs in LabVIEW is done much in the same manner as opening a file in a typical word processing software application. The user can open an existing VI by using the pull-down menu **File** and selecting the **Open** command. This will then prompt the user to identify the VI to be opened (where ever the VI is located as specified by the user). Multiple VIs can be opened at any one time. Displaying VIs simultaneously is also possible. The user can choose to have both the front panel and the block diagram

open on the screen. This enables the user to see any changes made to the VI—in a real time fashion. For example, a change made to the front panel will result simultaneously in a terminal being created within the block diagram. This is beneficial for de-bugging corrupt or dysfunctional VIs or for adding features (functions, objects, and wiring), in a manner that allows the user to see real time what is happening to the VI.

Closing VIs is also similar to closing files in most common software applications. The user can use the pull-down **File** menu and close a VI by clicking the **Close** command. The user will then be prompted to save changes to the VI (provided changes were made), and then close the VI accordingly. Unless the users specifies a different file path for saving the VI, the VI will be saved in the location from which it was opened.

#### *h. Running VIs*

There are two modes for running VIs once a VI has been opened. Upon opening an existing VI, the user can select from two methods to run the VI; the ‘single run’ mode or the ‘continuous run’ mode. The single run mode executes the VI once; the VI executing once in its entirety and aborting execution upon completion. The push-button for a single run is displayed as a single arrow ( $\Rightarrow$ ) icon and is on the front panel in the upper left corner (the reader should note that VI can be executed in the block diagram as well, the single run arrow being located in the same position as seen on the front panel).

The second method for running a VI, called the continuous run mode, enables the VI to be run continuously for a specified period of time as commanded by the user. Depending on the design of the VI, continuous run mode may result in successive runs of the VI based on a time delay programmed into the VI. Once the VI has been placed in a continuous run mode, the VI will continue to run until the user aborts execution (NOTE: VIs can be programmed to abort execution after a specified amount of time or samples. In this situation, the user need not abort execution as the VI will abort execution in accordance with its source code). The continuous run mode icon is also located in the upper left corner (right of the single run arrow ( $\Rightarrow$ ) icon) of the front panel or the block diagram. The continuous run mode icon is displayed as ( $\curvearrowright$ ) with arrows pointing clockwise and counterclockwise.

In addition to the run modes icons, two other icons are located to the right of the run modes. These are the 'abort execution' icon and the 'pause' icon; these appear as (●) and (| |) respectively. The abort execution icon push-button stops the VI from running regardless of what run mode is selected. The pause icon push-button allows the user to momentarily stop the VI execution. This is helpful if resetting the front panel or adjusting the instrumentation device is required. Initiating the pause push-button icon after once pausing the VI, results in the VI continuing its execution from where it stopped.

When running the VI from the block diagram, the user will notice a 'light bulb' icon to the far right of the pause push-button icon. Initiating the light bulb icon followed by executing the VI in either run mode, runs the VI in a slow motion manner. In this slow motion mode, the user will see the VI executing module by module throughout the block diagram. This is most beneficial in de-bugging errors in program code that are not visual when running in a real time execution. If an error is present, the VI will terminate at the location (node, object, subVI, etc.) within the block diagram. At this point, the user can use the **Show Errors** command (under the **Windows** menu), to identify errors and to gain information on how to correct the errors. This option is the best method for de-bugging program code and for identifying casual errors that prohibit the VI from executing correctly. The user is able to determine if the VI is correctly programmed by the appearance of the single run icon. If the ( $\Rightarrow$ ) icon is broken ( as such,  $\neq\Rightarrow$ ), the user can quickly identify the nature and location of the errors using the light bulb icon run method as described above.

#### 4. **GBSTESTBED.VI**

##### *a. Front Panel of GBSTESTBED.VI*

Having discussed LabVIEW software capabilities and functionality in general terms, this section addresses the VI developed for use in the NPS GBS Testbed. The VI is titled GBSTESTBED.VI and is fixed from editing by the locking feature available in LabVIEW. This VI is used for data acquisition through a GPIB interface with the HP 8568B spectrum analyzer. As stated previously, all VIs are associated with both a front panel and a block diagram. Figure 13 is the front panel of the GBSTESTBED.VI. An explanation of the front panel is provided below.

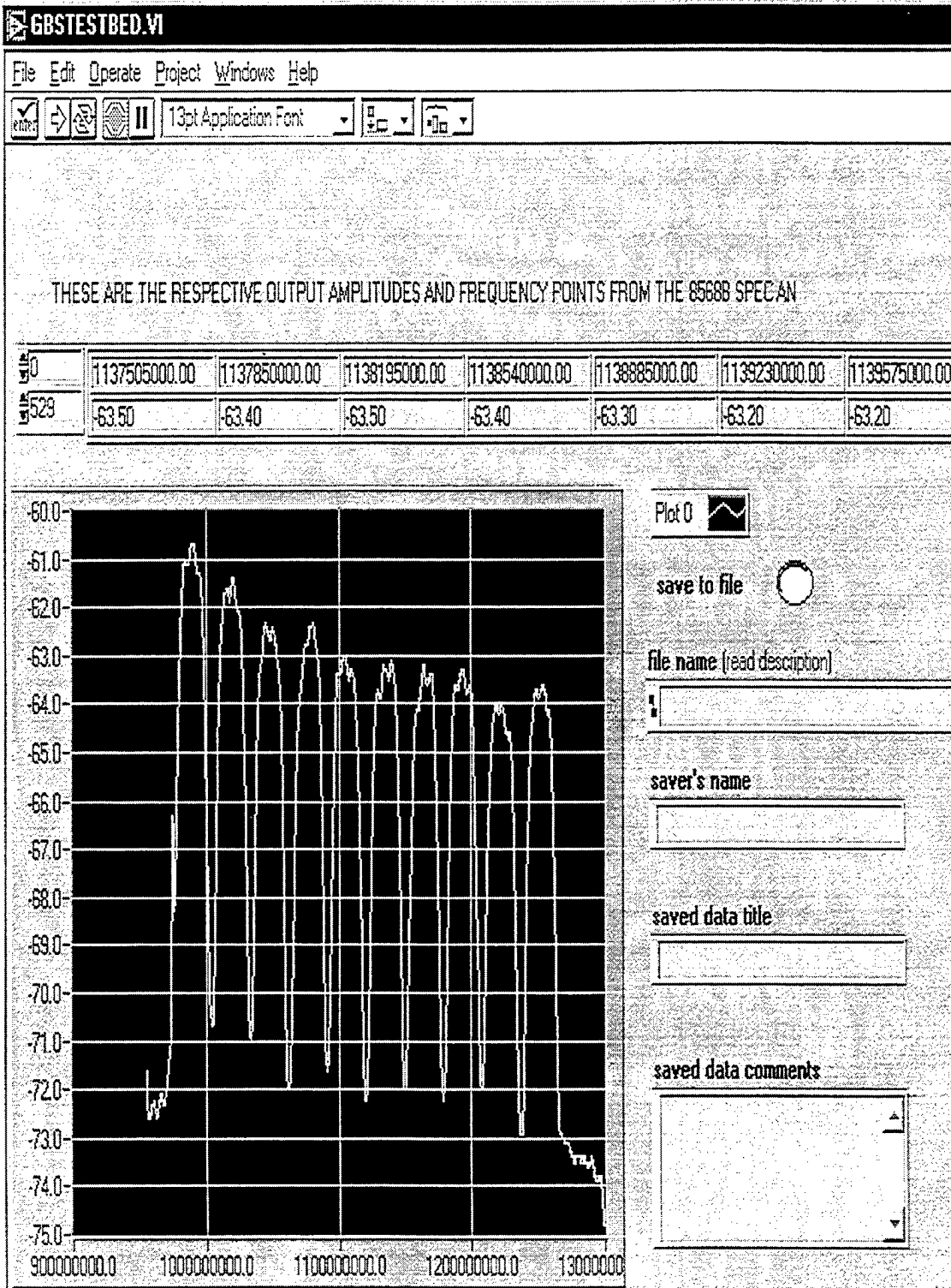

Figure 13 Front Panel of the GBSTESTBED.VI

The front panel as shown in figure 13 is what the user will see when first opening the GBSTESTBED.VI. This front panel is designed to look very similar to the front panel of the HP 8568B spectrum analyzer. In the above section of the front panel, the reader will notice a 2 X 529 matrix which when the VI is executed, displays the resulting frequency values in the first row, and the amplitude values in the second row. The sample size shown on the front panel displays 529 readings. The reader will note that the total sample size at each execution of the VI is 1001. For obvious reasons, all 1001 samples are not displayed on the front panel. The program code for initiating 1001 samples is located in a subVI which is called by the GBSTESTBED.VI during execution. The subVI is described later in this chapter.

The graphical display is similar in appearance to what the user will see on the HP 8568B spectrum analyzer. The X-axis is in frequency (Hz) and the Y-axis displays the amplitude (dB). Prior to the execution of the VI, the user will pre-set the spectrum analyzer's start and stop frequencies based on the expected incoming signal being evaluated. For example, if we know that a satellite signal (multiple transponders) are using the L-band frequency spectrum (950 to 1450 MHz), the spectrum analyzer's start frequency would be set at 950 MHz and the stop frequency at 1450 MHz. The amplitude is dictated by the output of the spectrum analyzer and is not adjustable by the user at the beginning of a sample execution. Therefore, whatever amplitudes the incoming signal is registering, those same amplitudes will appear on the front panel graphical display of the VI.

To the right of the graphical display, the reader will note a series of input options that the user can elect to fill in if desired. The first option is the save option. This VI can be executed with a save option or it can be run without saving any of the data. If the user wishes to save the incoming data, they will depress the save push button on the screen. Below the save push button, is the file name specification path for where the data is to be saved. This option allows the user to save data to any drive or location desired and in any format desired as well. For example, if the user elects to save the data to the PC's hard-drive as a data file, the user would input something like [c:\datacollection\test1.dat]. This command would save the incoming signal data to the folder *datacollection* as a data type file. This is especially useful when using particular software applications (i.e. Matlab) that require specific formats for retrieval of data.

Below the file name specification block is the saver's name input. This is fairly straight forward—one can identify the name of the user saving the data file. In

addition, the user can also title the data and input specific comments relevant to the particular test run being conducted. An example of such an entry might be when testing is conducted in poor weather conditions. Adverse weather conditions can greatly affect satellite link performance. Identifying this in the saved data comments section can be beneficial when looking back at the data during analysis and data manipulation.

The following defines each input function:

**file name (read description)**

This is the name of the file where the data will be saved. Data is saved in ASCII format with a header consisting of the “saver’s name”, “saved data title”, “saved data comments”, and the date and time the data was collected.

**saved data title**

Title of the data to be saved.

**saved data comments**

Comments on the data to be saved.

**saver’s name**

Name of person(s) saving file.

**save to file**

This button controls whether data is saved to a file. It is a true/false condition where False = do not save to file and True = save to file.

***b. Block Diagram of GBSTESTBED.VI***

Associated with each front panel of a VI is the VIs block diagram. The block diagram is easily accessible by either using the pull down menu under **Windows** or using the ‘hot-key’ Ctrl E. Both of these methods will allow the user to toggle back and forth between the front panel and block diagram of the VI. Figure 14 is the block diagram of the GBSTESTBED.VI. It will be explained below.



In explaining the thought process and design behind the GBSTESTBED.VI, we will start in the upper left hand corner of the block diagram. Initially, the reader will notice a small box containing the number 18. This box represents the GPIB primary address between the LabVIEW VI and the instrumentation device. The programmer can select the GPIB address number but must ensure that they are identical in the program code as specified in the instrumentation device's memory. For the GBSTESTBED.VI, the number 18 was chosen. This GPIB address signifies the computer to interface with the instrumentation device on PCMCIA-GPIB slot 0 address 18. This initializes the interface and maintains a path for communication between the device and the PC. The user can easily change the GPIB address by using the *shift-P* command on the front panel of the spectrum analyzer. Issuing this command prompts the user to select a GPIB address (1 to 40) on the CRT display on the spectrum analyzer. Enter the address and depress the Hz push button to store the address in the instruments memory. This same address must be selected in the LabVIEW VI GPIB address box, thus establishing communication over that addressed path . Once the interface is in place, control and data transfer is continuous and resulting data flows out of the GPIB address box into the subVI titled HP 8591A Read Axis VI. Although this VI is ideally used with the HP 8591A spectrum analyzer, it is compatible with the HP 8568B instrumentation device. The specific design features and explanation of the HP 8591A VI will be addressed later in this chapter. For now, it is only necessary to understand that this subVI is responsible for generating an array of length 1001, containing frequency or time values in external engineering units corresponding to each horizontal axis trace point of an HP 8568B spectrum analyzer. This array is used in conjunction with a trace amplitude array to graph and scale trace data acquired from the instrument device (in this case the HP 8568B). Figure 15 is a closer view of the GPIB address box and the output wiring into the HP 8591A Read Axis subVI as described above.

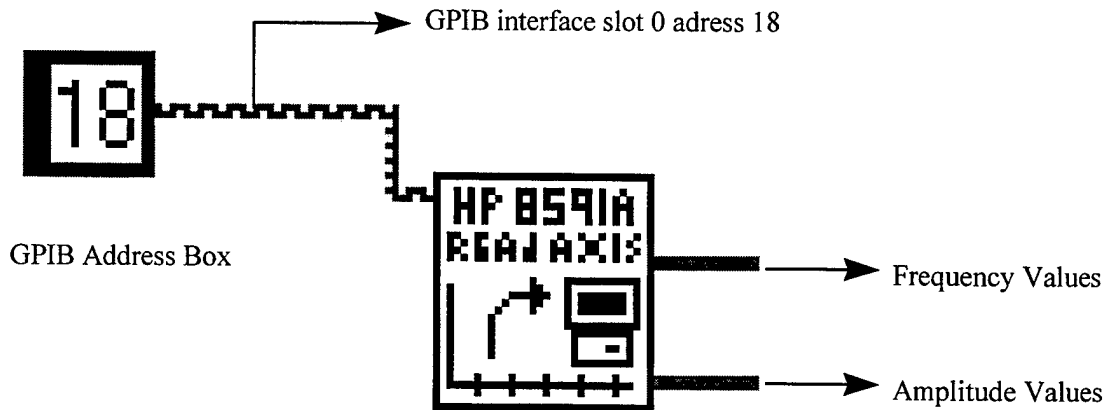

HP8591A Read Axis VI  
being used as a SUBVI  
in GBSTESTBED.VI

Figure 15 GPIB Address Box and HP 8591A Read Axis VI

Upon completion of the HP 8591A subVI routine, the data arrays exit the subVI and are then wired to a delay function. The delay function waits a specified number of milliseconds and returns the millisecond timer's end value. The specified number of milliseconds is modifiable by the user who can enter the desired delay specifications in the input box. The delay function is encapsulated in a case structure which is common in LabVIEW for specifying a data bridge transfer of any sort. The delay function serves for segmenting data samples into desired sampling rates. For example, if 600,000 milliseconds is chosen, the VI will collect data from the HP 8568B spectrum analyzer every 10 minutes and output the data to the file specified in the destination path.

When the delay function returns the timer's end value, the value is then sent to the first Build Array function. The purpose of the Build Array function is to concatenate inputs (data elements such as the frequency and amplitude values from the HP 8568B spectrum analyzer), in top-to-bottom order. This function is re-sizable and may be re-sized by the user if desired. The Build Array function accepts an array in conjunction with a series of elements (frequency and amplitude values). The output array is a new array with appended elements.

The new array with appended elements is then forwarded to a Bundle function. The bundle function assembles input components into a single cluster, or replaces elements in an existing cluster. This function is also re-sizable and can be modified by the user if desired. The function serves to ready the data elements for export to the 'save data to file' case structure as seen in the lower right corner of the block diagram. Figure 16 below shows the transgression of the VI from its origin (at the GPIB address box) up until the Index and Bundle Cluster Array Function.

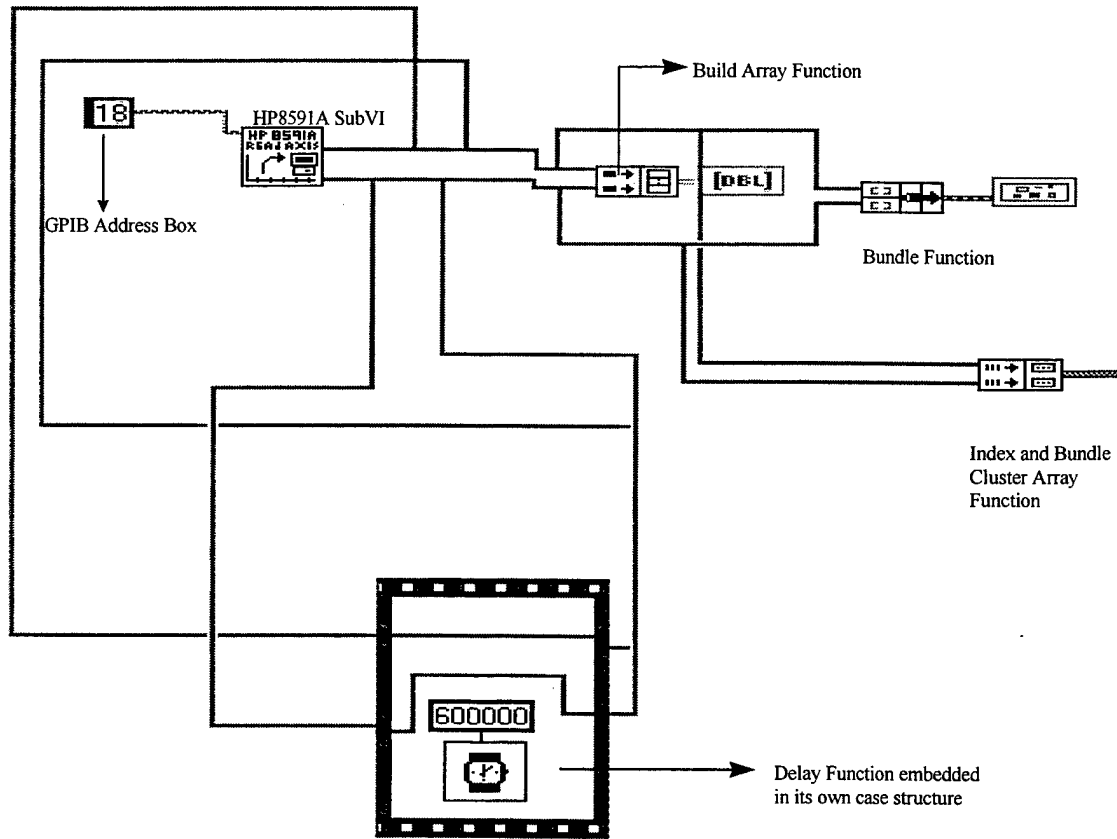

Figure 16 Transgression Path for the GBSTESTBED.VI

Before entering the save to file case structure, the data elements (now in cluster form), are submitted to a final function called a Index and Bundle Cluster Array. This function creates an array of clusters where each element is a grouping of the corresponding elements of the input arrays. For example, given the arrays [1,2,3] and [4,5,6], this function produces the array [{1,4}], {2,5}, {3,6}. Likewise, this function is

re-sizable. With regards to the data being collected, this function allows for corresponding frequency and amplitude values to be matched with reference to when their sample was taken.

The new array(s) created are now ready to enter the save to file case structure. The reader will notice that the data entry point is at the top of the case structure and proceeds downward to the entry point of an internal case structure. The data is first subjected to a Boolean true false condition. If the user has selected the save option, then the true condition is met which in turn will allow the save to file case structure to accept data. If false, then no data is saved to file.

Let us assume the user has specified a destination file path for saving the frequency and amplitude data from the instrumentation device. The Boolean True/False condition registers a True indication and allows for data transfer into the save to file case structure. The incoming data first enters an Unbundle Function. The Unbundle Function splits a cluster (incoming cluster consisting of frequency and amplitude data), into its individual components. In the GBSTESTBED.VI, the Unbundle Function splits the incoming cluster into the frequency and amplitude components of the receive data. This is done so that the frequency and amplitude components can be formatted correctly for output to the saved file annotated in the destination save path. The formatting of the frequency and amplitude data is accomplished via the Format and Append Function(s) located to the right of the Unbundle Function in the block diagram. Refer to Figure 17 below which shows in greater detail the specific area within the block diagram where this de-bundling and formatting is taking place.

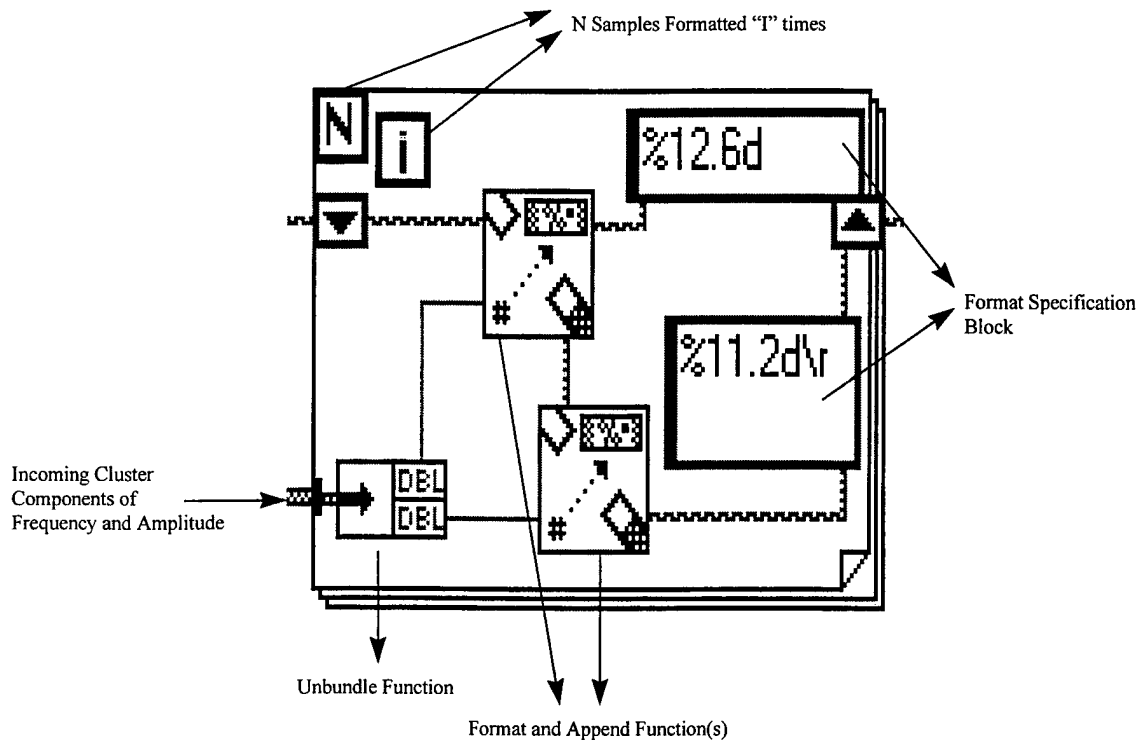

Figure 17 Format and Append Case Structure

The reader will note that along side each of the Format and Append Functions are input boxes where the user can specify what format the data is to be stored in. Formatting criteria and choices will be discussed later in this chapter. For now, the reader needs to understand that the data format is dictated by the input parameters placed in the format specification blocks. The symbols “N” and “I” in the upper left hand corner indicate that the formatting is to occur on N number of samples (1001) I amount of times. This formats the incoming 1001 data points sequentially sample by sample.

While the incoming clustered data is entering the internal save case structure, so is a series of user input specifications. These user input specifications (as mentioned before) are the following:

- **Saved By header:** User specifies who (name of file owner) is saving the file.
- **Title:** User can title the output data file... i.e. DVB data set.
- **Comments:** User can input comments relevant to a particular data acquisition run. For example, “Data accumulation conducted during rain showers”.

- **Date:** Date of data acquisition is stamped on the output file.
- **Time:** Time of data acquisition is stamped on the output file.
- **Stimulus and Response:** Stimulus refers to frequency, Response to amplitude.

All of these inputs are funneled into a Concatenate Function which simply concatenates the inputs into a single header (string) that appears at the beginning of the output save file, and at the beginning of every sample. Of the six input fields to the Concatenate Function, the Date and Time parameters are not entered by the user; the remaining four (Saved By, Title, Comments, Stimulus and Response) are. The Date and Time values are produced by the Get Date/Time String Function which outputs the date and time specified by the number of seconds expired since 12:00 am, Friday, January 1, 1904 Universal Time. This is a function inherently linked to the PC's internal clock and simply replicates the given date and time at execution of the VI. Figure 18 displays the section of the VI containing the input specifications and the Get Date/Time String Function.

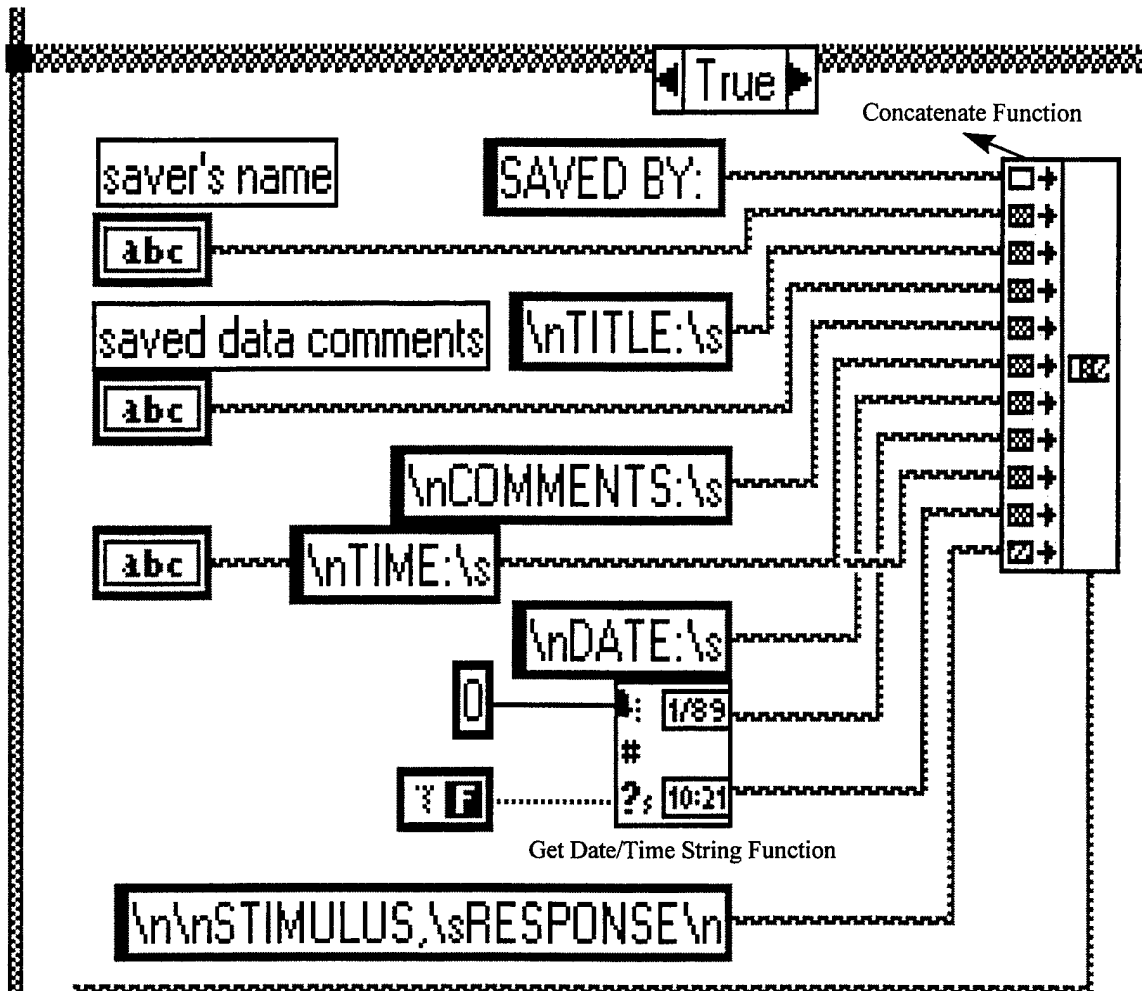

Figure 18 Input Specifications to Concatenate Function

In looking at figure 18, the reader will notice a series of back-slashes followed by small case “n” or “s” characters located within the header specification blocks. In the output data file, the header reads top-to-bottom starting with “saved data” and ending with the “date”. The back-slash \n signifies to LabVIEW to insert a new line at the end of the input field while \s commands a space after the colon on each input line. The back-slash formatting commands are described later under the Formatting of Data section.

The concatenation string outputs to the internal case structure containing the Format and Append Functions. The internal case structure (Figure 17) combines the concatenated string with the specified data formats for a combined output file which then proceeds out of the internal case structure to the “output” file contents block. This block

is linked by virtue of the save to file case structure, to the Text File Function VI. This VI is designed to be used with the HP 8753B Network Analyzer for reading and writing strings to and from disk. However, this VI is compatible with the HP 8568B spectrum analyzer and serves the same purpose in its context as used here. The Text File VI allows a default path and dialog box to be set by the user. It also allows the user to enter a special dialog box prompt—such that if a file is selected to be written to which already exists, the user will be queried if s/he really desires to overwrite the file. Figure 19 displays the Text File Function VI.

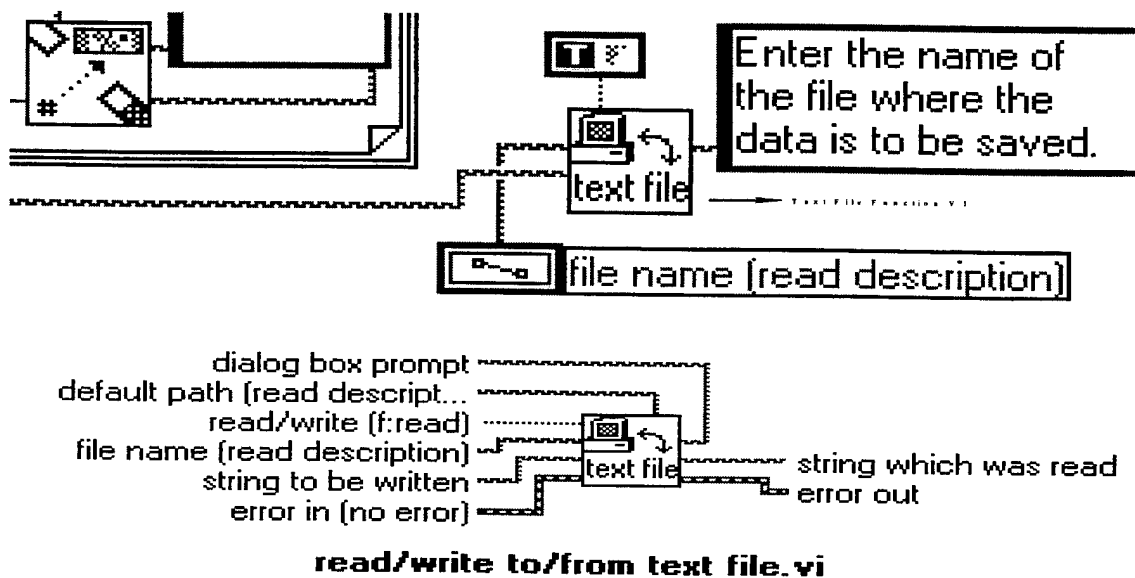

Figure 19 Text File Function VI Up-close

## 5. GBSSUB.VI

Having discussed the elements (function VIs) that make up the GBSTESTBED.VI block diagram, the next VI to be described is the subVI titled GBSSUB.VI (same as HP 8591A Read Axis VI). Recall that this subVI is called immediately following the interface made between the HP 8568B spectrum analyzer and the PCMCIA slot 0 address 18 as identified in the GPIB address box.

The primary function of the GBSSUB.VI is to provide a traceable plot of the frequency and amplitude values being generated by the HP 8568B spectrum analyzer. The subVI is self correcting in that it will report errors in and errors out—if errors are

present in the transgression of data through the block diagram. These types of errors might be a function of the programming code or the mismatch between frequency and amplitude sampling. The HP 8591A subVI generates an array of length 1001, containing frequency and amplitude values in external engineering units corresponding to each horizontal axis trace point of an HP 8568B spectrum analyzer. This array is then used in conjunction with a trace amplitude array (mentioned above), to graph and scale trace data acquired for the instrument.

*a. Front Panel of GBSSUSB.VI*

The author will begin describing the specifics of the GBSSUB.VI (HP 8591A Read Axis VI) front panel in the same manner as was done with the GBSTESTBED.VI. Figure 20 is the front panel of GBSSUB.VI. The user will first see this front panel when accessing this subVI.

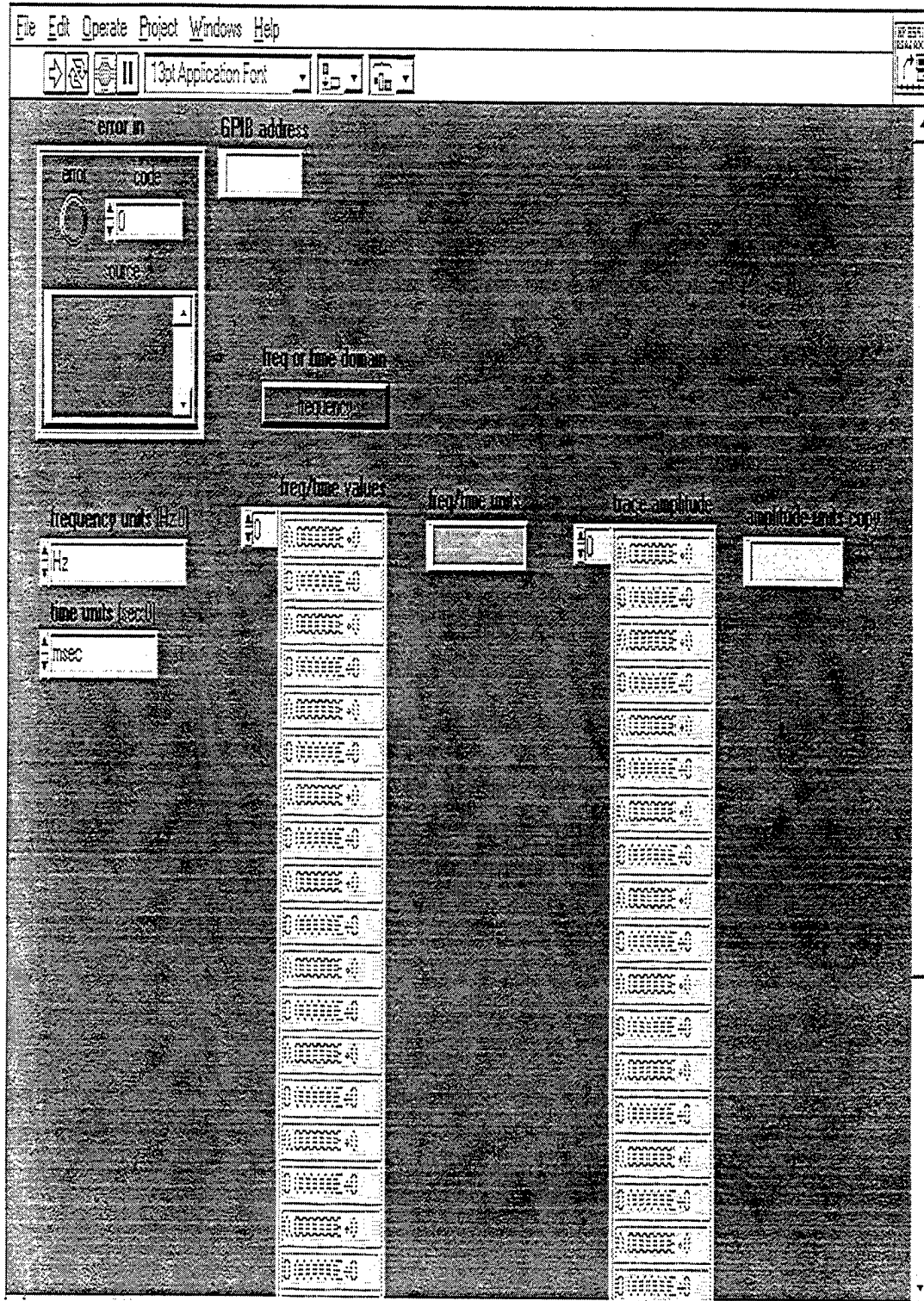

Figure 20 Front Panel of GBSSUB.VI

The front panel of the GBSSUB.VI is very straight forward. Starting in the upper left hand corner, the error in code box serves to identify the user of any input errors generated as a result of sampling mismatch or source code errors. To the immediate right of the error in box is a GPIB address box that serves the same purpose as the address box in the top level GBSTESTBED.VI. Again, this address must be equivalent to address specified in the top level GBSTESTBED.VI (GPIB address 18 in the case of the GBSTESTBED.VI). Looking downward in the diagram, the frequency/time and trace amplitude columns each with modifiable unit representation, are displayed. In addition, the user can specify frequency units and time units as seen to left of the frequency/time column.

The following is a brief description of each input parameter to include definition of, conditional situations (if applicable), and selection of unit(s):

**Frequency Units (Hz:0):**

Definition: Selects the frequency domain units for Frequency/Time values.

Condition: This setting is ignored if Frequency/Time values contains time domain data.

Unit(s): 0(default) = Hz.

1 = kHz.

2 = MHz.

3 = GHz.

**Time Units (sec:0):**

Definition: Selects the domain units for Frequency/Time Values.

Condition: This setting is ignored if Frequency/Time values contains frequency domain data.

Unit(s): 0 (default) = sec.

1 = msec.

2 = usec.

**Error In:**

Error:

Definition: Indicates the presence of an error condition.

Code (of error in):

Definition: Code representation for errors in displayed on the front panel VI.

**Instrument driver errors:**

Code	Meaning
1210	Parameter out of range
1220	Unable to open instrument
1221	Unable to close instrument
1223	Instrument identification query failed
1225	Error triggering instrument
1226	Error polling instrument
1228	Error writing to instrument from file
1229	Error reading from instrument to file
1230	Error writing to instrument
1231	Error reading from instrument
1232	Instrument not initialized (no GPIB address)
1234	Error placing instrument in local mode
1236	Error interpreting instrument response
1239	Error in configuring time out
1240	Instrument timed out
1300	Instrument-specific errors

**Source:**

Definition: The name of the VI or the routing originating the error message. In the event of instrument specific errors (code 1300), messages reported from the instrument are also included.

**Trace (A:0):**

Definition: Selects the trace to acquire.

Unit(s): 0 (default) = Trace A.

1 = Trace B.

2 = Trace C.

**Frequency/time values:**

Definition: This array indicator contains the numeric frequency or time associated with each of the 1001 points and a corresponding trace amplitude array. The domain of units is indicated by Frequency or Time domain. The units within each domain are as specified by the Frequency Units and Time Units and control inputs to the VI.

**Array of length 1001:**

If the instrument is in a non-zero frequency span, it contains linearly interpolated frequency values. Element 0 = instrument start frequency and element 1000 = instrument stop frequency as dictated by the user. If the instrument is in zero span, it contains linearly interpolated time values. Element 0 and element 1000 = instrument sweep time. The domain of units is indicated by the frequency or time domain. Units within each

domain are selected by the frequency units and time units controls. Units are indicated by Freq/Time Units.

**Frequency or Time domain:**

Definition: The domain of data in Frequency/Time values.

F= frequency domain

T= time domain

**Freq/time units:**

Definition: The units associated with the data in Freq/Time values.

String values are HZ, Khz, Mhz, Ghz, Sec, msec, and usec.

**Trace Amplitude:**

Definition: This array contains the numeric amplitude values of the acquired trace. Units are indicated by Time and Amplitude Units. Array is of length 1001 containing trace amplitude values in dBm, dBmV, dBuV, Volts, or W. Units are indicated by Amplitude units.

**Error out copy:**

Definition: Indicates the presence of an error condition.

Code (of error out):

Definition: Code representation for errors out displayed on the front panel VI.

Instrument driver errors:

Code	Meaning
1210	Parameter out of range
1220	Unable to open instrument
1221	Unable to close instrument
1223	Instrument identification query failed
1225	Error triggering instrument
1226	Error polling instrument
1228	Error writing to instrument from file
1229	Error reading from instrument to file
1230	Error writing to instrument
1231	Error reading from instrument
1232	Instrument not initialized (no GPIB address)
1234	Error placing instrument in local mode
1236	Error interpreting instrument response
1239	Error in configuring time out
1240	Instrument timed out

***b. Block Diagram of GBSSUB.VI***

The GBSSUB.VI block diagram is quite complicated and for the purpose of this writing will only be discussed in short detail. Figure 21 is a portion of the GBSSUB.VI block diagram. The figure displays the frequency trace case structure portion of the source code. For all practical purposes, the amplitude trace case structure is equivalent with the exclusion of unit(s) differentiation. From the user perspective, this portion of the total VI (GBSTESTBED.VI) is not to be modified with the following exception: Within this block diagram is the input box for modifying the sample size criteria (set at 1001 within the GBSSUB.VI).

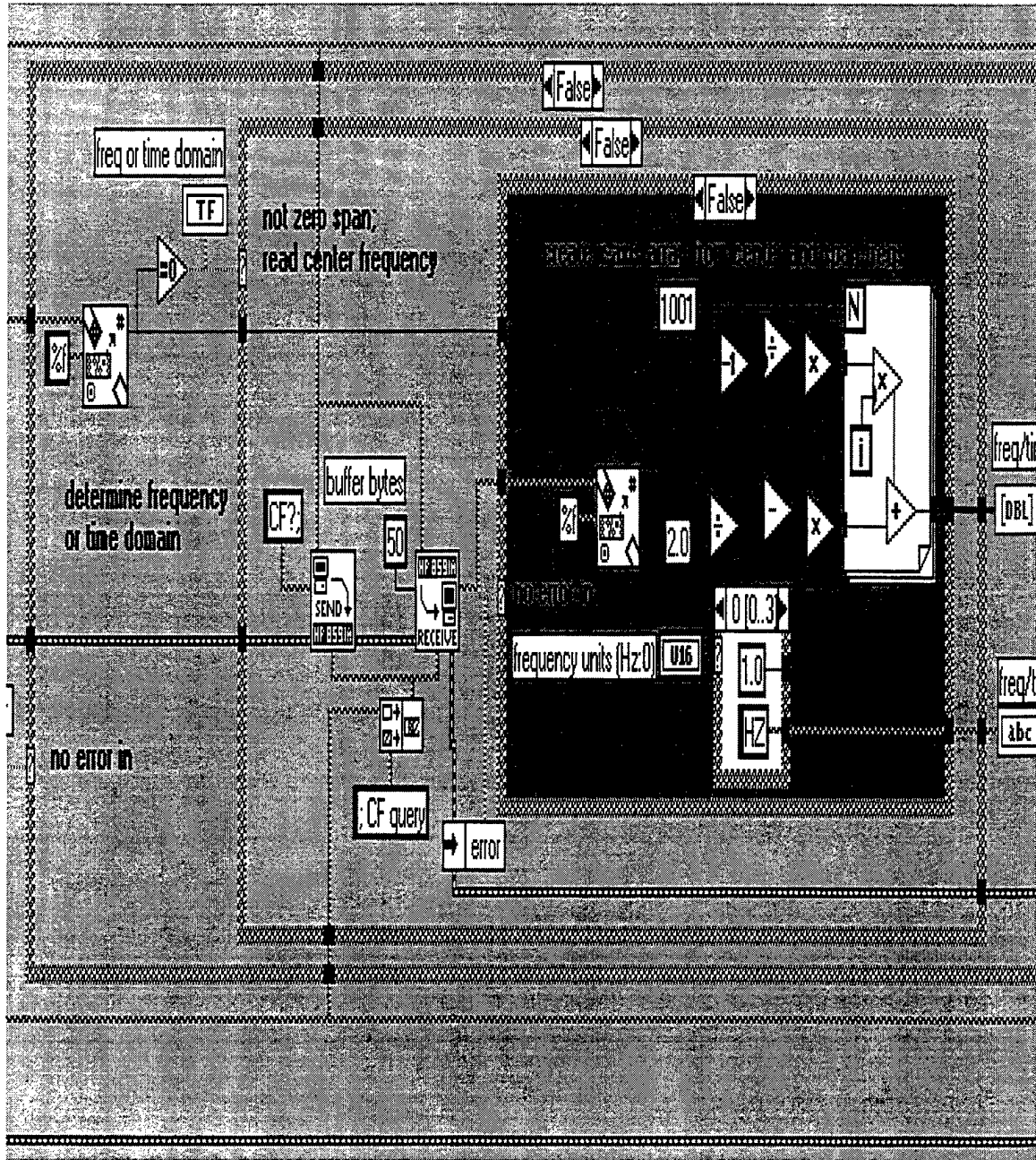

Figure 21 Frequency Case Structure of GBSSUB.VI Block Diagram

In explaining the functionality of the block diagram above, the reader must understand that this VI in and of itself is a subVI called upon by the top-level GBSTESTBED.VI. The GBSSUB.VI generates an array of length 1001, containing frequency, time, and amplitude values in external engineering units, corresponding to

each horizontal axis trace point of an HP 8568B spectrum analyzer. The array is then used in conjunction with a trace amplitude array to graph and scale trace data acquired from the instrument. This graphical display is seen during execution of the top-level GBSTESTBED.VI on the front panel portion of the VI.

The block diagram source code for the GBSSUB.VI executes by calling on its own internal subVIs. These subVI(s) (which are explained below), are the following: 1) HP 8591A Send Message.VI 2) HP 8591A Receive Message.VI 3) General Error Handler.VI , and 4) HP 8591A Error Report.VI.

Initially, the General Error Handler.VI is called upon which primarily informs the user if an input error exists. If an error exists, the VI identifies where it has occurred. The information for error identification is derived from the Inputs Error in, Error Code (as described previously under the Error In/Error out specifications to the GBSSUB.VI on pages 65 to 69), and error source, and from an internal error description table. The table has provisions to take alternative actions, such as to cancel or set an error status, and to test for and describe user-defined errors.

Provided an error has not occurred, the HP 8591A Send Message.VI sends a string to (in this case) an HP 8568B spectrum analyzer connected to a GPIB address (GPIB address 18 for the GBSTESTBED.VI). Conversely, the HP 8591A Receive Message.VI receives a string from an HP 8568B spectrum analyzer connected to the same GPIB address. From this point, the trace data is forwarded to the top-level VI (GBSTESTBED.VI) for graphical display on the front panel.

If an error has occurred, the HP 8591A Error Report.VI is called. This VI queries the HP 8568B spectrum analyzer for two reportable errors: the illegal command and hardware broken. These errors are described in pages 65 to 69. The VI polls (and clears) the status byte (error or no error) and if the error query global is set (error = true), and there is no error in the incoming error cluster, then this VI will continue conducting the serial poll until it locates a reportable error. If a reportable error has taken place, the Error Report.VI generates an error message to the user.

The user may want to modify the sampling size in different testing scenarios. Should the user elect to do so, the input box is located in the upper right portion of the block diagram and is shown in Figure 22 with the sampling size at 1001. A closer view of this input box is provided below in Figure 22.

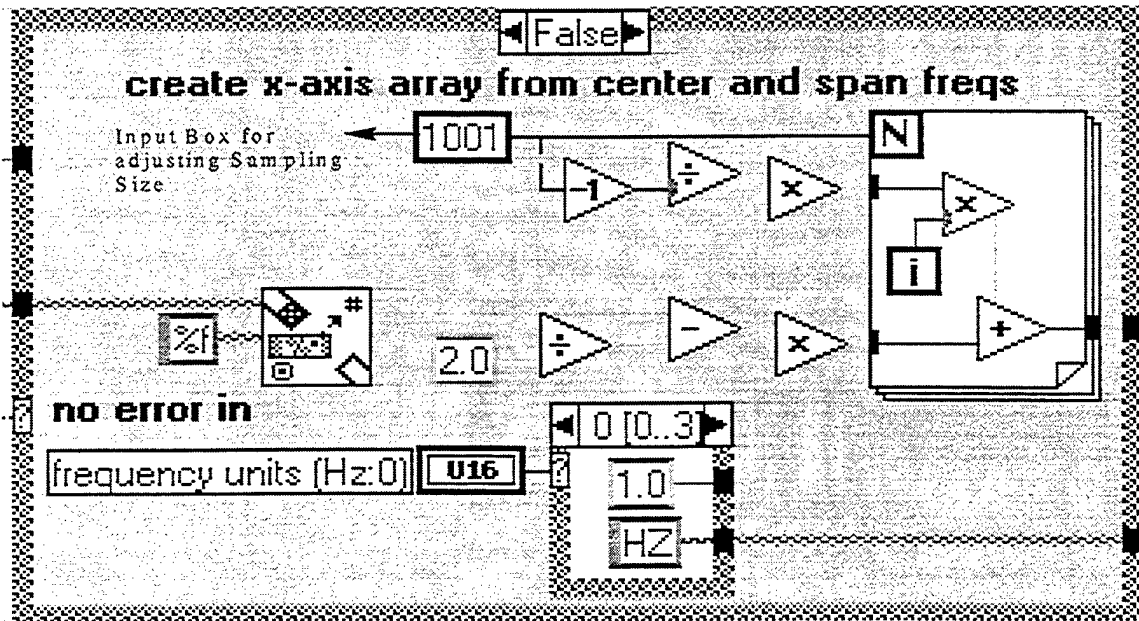

Figure 22 Input box for Modifying Sample Size Criteria

For no other reason should the user have to manipulate or change the settings in this block diagram portion of the GBSSUB.VI. Should the user wish to change the sample size, s/he can do so using the **Tools Palette** text entry icon. Place the “small hand” icon into the sampling size specification box and then change the input sampling size required. Complete the modification by depressing the <Enter> push-button in upper left hand corner of the block diagram and then save the VI under a different name. This will result in a new version of the VI with a different sampling rate.

## 6. VI Hierarchy

In order to summarize the complete GBSTESTBED.VI, the best means to do so is to reference the VI hierarchy. Shown below in figure 23 is the VI hierarchy displaying the top-level VI (GBSTESTBED.VI) with subsequent subVIs in a top-to-bottom fashion. The data flow is marked by the wire flow in and out of the various subVIs and functions where applicable. Upon execution of the GBSTESTBED.VI, the transition begins at the top-level and sequentially works its way through the GBSSUB.VI—back to the top-level, and then to the Text File function where the formatting and saving of the acquisition data takes place. This figure provides the reader with an overview of how the VI executes from start to finish.

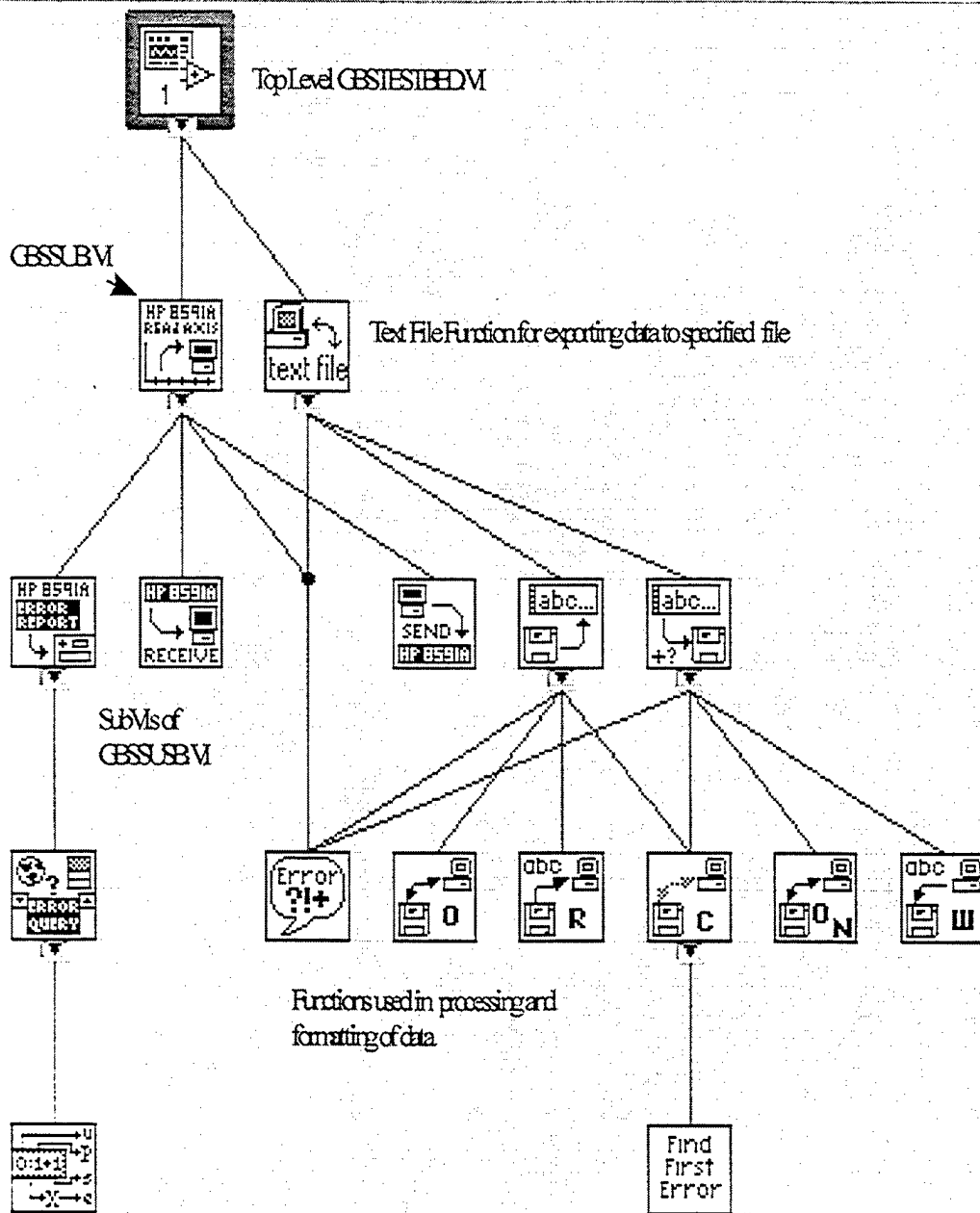

Figure 23 VI Hierarchy

## B. RECORDING DATA

### 1. Data Formats

The GBSTESTBED.VI is designed with user modifiable formatting (please refer to Figure 17 Format and Append Functions, pg. 59 ) in an effort to support multiple formats that might be required depending on software applications potentially used in analyzing collected data. Fortunately, LabVIEW provides this feature. Formatting of data becomes especially critical when attempting to use statistical or analysis software that requires specific data formatting. For example, use of Math Work's Inc. Matlab software requires flat ASCII type files. Consequently, the GBSTESTBED.VI was designed with this requirement in mind. To understand how this requirement is met, an explanation of how LabVIEW converts stored formatted data to flattened ASCII data is warranted.

There are two LabVIEW internal functions that convert data from the LabVIEW memory storage format to a form more suitable for writing to or reading from a file (flattened data). Because strings and arrays are stored in handle blocks, clusters containing these types are discontinuous. In general, data in LabVIEW is stored in tree form. For example, a cluster of a double -precision floating-point number and a string is stored as an 8-byte floating number, followed by a 4-byte handle to the string. The string data is not stored adjacent in memory to the extended-precision floating-point number. Therefore, if the user wants to write the cluster data to disk, s/he has to get the data from two different places. Of course, with an arbitrarily complex data type, the data may be stored in many different places [Ref. 11].

When LabVIEW saves data to a VI file or a datalog file, it flattens the data into a single string before saving it. This way, even the data from an arbitrarily complex cluster is made contiguous, instead of being stored in several places. When LabVIEW loads such a file from disk, it must perform the reverse operation—it must read a single string and inflate it into its internal LabVIEW form.

LabVIEW normalizes the flattened data to a standard form (ASCII) so that the data can be used unaltered by VIs running on any platform. It stores numeric data in *big endian* form (most significant byte format), and it stores extended precision floating-point numbers as 16-byte quantities using the Sun extended-precision format. Similar transformations may be necessary when reading data written by an application other than LabVIEW.

When writing data to a file for use by an application other than LabVIEW (such as Matlab), the user needs to transform the data after flattening it. Windows applications typically expect numeric data to be in *little endian* form (least significant byte first) [Ref. 11]. This is the case with Matlab Statistical Analysis software.

The function responsible for ensuring output data is formatted correctly for Matlab software recognition is the Format and Append. As discussed previously, the Format and Append function converts format string(s) into regular LabVIEW string(s), converts numbers into numeric fields within the format string, and then appends converted string(s) to flattened string(s). The format string has the following syntax: Double brackets ( [ ] ) enclose optional elements. A typical format string syntax looks like:

[String]%-[WidthString][.PrecisionString]

The following table explains the elements of the preceding syntax.

<b>Syntax Element</b>	<b>Description</b>
<b>String (optional)</b>	Regular string in which you can insert certain characters as described below.
<b>%</b>	Character that begins the formatting specification.
<b>- (dash) (optional)</b>	Character that left justifies rather than right justifies the converted number within its width.
<b>0 (zero) (optional)</b>	Character that pads any excess space to the left of the number with zeros rather than spaces.
<b>WidthString (optional)</b>	Number specifying the minimum character width of the numeric field that contains the converted number. More characters are used if necessary. LabVIEW pads excess space to the left or right of the number with spaces, depending on justification. If WidthString is missing or if the width is zero, the converted number string is as long as necessary contain the converted number.
<b>. (period)</b>	Character that separates WidthString from PrecisionString.
<b>PrecisionString (optional)</b>	Number specifying the number of digits to the right of the decimal point in the numeric field when number is a floating-point number. If PrecisionString is not followed by a period, a fractional part of six digits is inserted. If WidthString is followed by a period, and PrecisionString is missing or zero, no fractional part is inserted.

Table 7 Format Specifications for LabVIEW Output Data  
(Taken from LabVIEW Function Reference Manual)

To insert non-displayable characters and the backslash and percent character within a string, use the codes described in Table 5 below.

<i>Code</i>	<i>Action</i>
<code>\r</code>	To insert Carriage Return
<code>\t</code>	To insert Tab
<code>\b</code>	To insert Backspace
<code>\n</code>	To insert New Line
<code>\f</code>	To insert Form Feed
<code>\s</code>	To insert a space
<code>\xx</code>	To insert a character with hex code xx using 0 through 9 and upper case A through F
<code>\\</code>	To insert \
<code>%%</code>	To insert %

Table 8 Codes for Inserting Non-displayable Characters into Output Data

The formatting string used in the GBSTESTBED.VI block diagram as specified in the format input box, is the following: frequency format string = [%12.6d], and the amplitude string, [%11.2f]. In the frequency string format specification, the % character indicates the characters to follow that will specify which format to be used. The number 12 represents the minimum character width of the numeric field and the number .6 indicates the number specifying the number of digits to the right of the decimal point in the numeric field when the number is a floating-point value. The ConversionCharacter input is d which specifies a decimal integer value. Likewise, in the amplitude format specification, the % character is equivalent, 11 represents the minimum character width, and .2 is the number of digits to the right of the decimal point. The amplitude ConversionCharacter input is f representing a floating-point number with scientific notation.

As revealed earlier, these format specifications are modifiable by the user. To do so is very easy and simply involves using the LabVIEW Tools Palette 'hand' icon for manipulating input parameters. The format specifications described above work well in exporting data to Matlab software—and for that reason, were selected. A typical data file display is provided below in Figure 24.

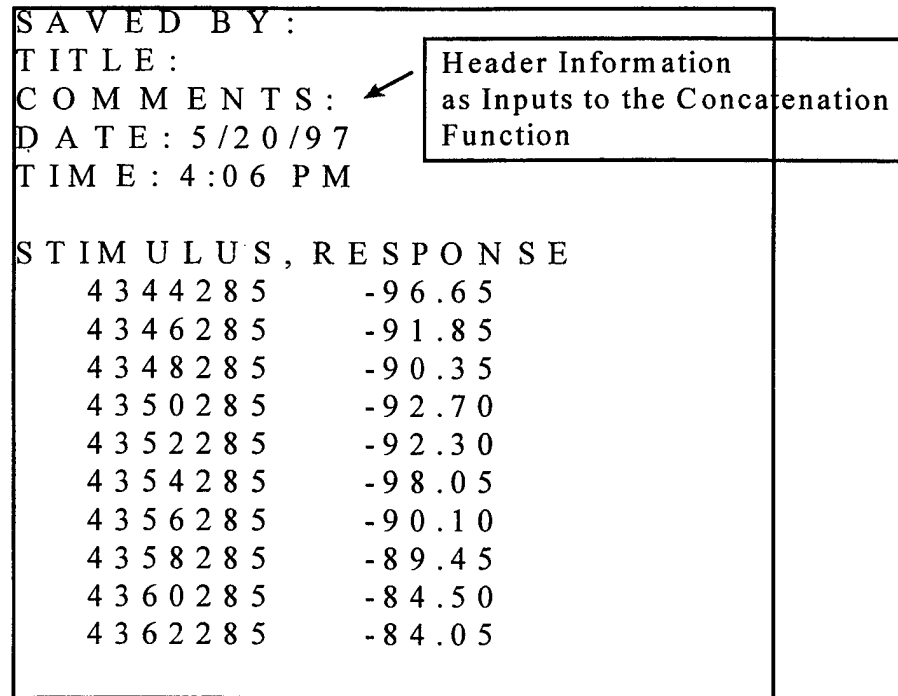

Figure 24 Output Data File with Header Information

## 2. Sampling Size

The sampling size chosen for the GBSTESTBED.VI is 1001 at each execution of the VI. Considering that the L-band frequency spectrum runs from 950 MHz to 2050 MHz, 1001 samples adequately covers the spectrum being observed. This is further proven to be adequate sampling criteria by the fact that at the onset of each data collection from the spectrum analyzer, the three satellite signals addressed in this instrumentation report do not contain signal content above 1500 MHz. The broadest signal content covers a frequency range of approximately 550 MHz (DVB at 950 MHz to 1500 MHz) which when sampled 1001 times, provides signal representation of approximately 2 samples per 1 MHz of signal content.

The sampling size can be modified in the GBSSUB.VI by changing the values in both the frequency and the amplitude case structures of the block diagram. The user should note that when changing the sampling size, it is imperative that for correct data exportation, the sampling sizes in each case structure (frequency and amplitude) match. If this condition is not met, Matlab software will not recognize the data in a M X N matrix format as required. Additionally, LabVIEW will not execute the VI correctly and will give an error message indicating that there is mismatch in sampling sizes specified.

### **3. Sampling Frequency**

Selection of the sampling frequency is entirely up to the user running the VI. For the purpose of this instrumentation report, 10 minute sampling was chosen for data acquisition. The data analysis and interpretation presented in chapter V is founded on sampling frequencies taken in 10 minute intervals. Each data set is an accumulation of signal data over a 24 hour period taken every 10 minutes for a total of 144 data sets. Total samples taken for a 24 hour period is

$$144 \text{ samples} \times 1001 \text{ data points} = 144144 \text{ frequency/amplitude values per 24 hours.}$$

Future data accumulation may require longer data acquisition and shorter delay in frequency of sampling, or vice versa. The VI designed here provides this type of flexibility and can be easily adapted for particular test scenarios as desired by the user. For example, in the event of data accumulation during adverse weather conditions (rain or fog), the sampling frequency would probably be specified for a shorter duration.

### **C. MATLAB®**

This section details the Matlab script and function files (.m files) created for data analysis, manipulation, and graphical display of the data accumulated using the LabVIEW virtual instrumentation process. Matlab is a technical computing environment for numerical analysis, matrix computation and signal processing with an easy to use graphical interface that has been developed by The Math Works, Inc. of Natick, MA. The basic data element of Matlab is a matrix that does not require dimensioning. Also, Matlab automatically handles complex variables. In addition to its remarkable features, Matlab was chosen for its superb analytical capabilities in working with large data sets (up to 15

Mega-bytes per data set). Matlab specifically allows for the retrieval, manipulation, graphical display, and user defined statistical computations of large data sets quickly and with ease.

### 1. Datafilter Function

The following text is the source code for the DataFilter Function developed to input the stored data files to Matlab.

```
function [freq,amp,samples_read] = datafilt(filename)
% DATAFILTM Function that reads in LabView data from GBSTestbed.vi
% This script strips header information from a data file.
% ex: [frequency, amplitude, No_of_samples] = datafilt('gbs.txt')
% Written by Colin R. Cooper and John A. Watkins
% Last Mod: 5/23/97
% clc
% filename = input('Enter name of Data File » ','s');
fid = fopen(filename);
samples_read = 0;
amp = []; % Set storage vector
while 1
    for n = 1:7
        Line = fgetl(fid); % Read past 7 lines
    end
    a = fscanf(fid,'%g %g',[2,1001]); % Read in the Data values
    freq = a(1,:);
    amp = [amp, a(2,:)'];
    Line = fgetl(fid);
    samples_read = samples_read + 1;
    if Line == -1, break,end % End of File encountered
end
fclose(fid);
% fprintf('\n%4.0f samples read \n\n',samples_read)
```

The function

```
[freq,amp,samples_read] = datafilt(filename)
```

is used to import and open data files created using the GBSTESTBED.VI. This function calls in the data file and strips the specific sample header information at intervals of 1001 lines. The DataFilter function reshapes the incoming 1001 rows X 2 column

matrix into a new matrix consisting of 1001 rows by the number of corresponding sample amplitude values. The frequency values remain constant throughout each sample and are therefore not repeated. Upon completion of the function sub-routine, the function returns variables selected by the user when calling the function. For example, the user might call the first input return variable 'frequency', the second 'amplitude', and the third, 'number of samples read'. The number of samples read returns the value of corresponding 1001 blocks segmented by each header. This serves a quick verification in determining if the desired number of samples were in fact recorded and saved to disk.

Input arguments for function Datafilter are defined as follows:

**filename** : The name of the file to which this function will strip the header information at the beginning of each sample contained in the data output file. The user is prompted to enter the name of the file at the execution of this function.

## 2. Stage 1 Function

The following text is the source code for the Stage 1 Function developed for Matlab.

```
% function [PC,pc, Fmhz]=stage1(Freq, Amp)
%           STAGE 1 GBS DATA FORMAT
% Inputs:   Freq is frequency vector in Hz
%           Amp is Amplitude matrix in dBm
% Outputs:  pc is power in milliwatts
%           PC is power in dBm
%           Fmhz is vector of frequencies in MHz
%
% Written by Paul H. Moose and John A. Watkins
function [PC,pc,Fmhz]=stage1(Freq, Amp)
Fmhz=Freq/1e6;
A=RG11(Fmhz, A)
%pause
[rr,cc]=size(Amp);
for n=1:cc
Amp(:,n)=A+Amp(:,n);
end
PC=Amp;
pc=10.^(Amp/10);
```

The function

```
[PC,pc,Fmhz]=stage1(Freq,Amp)
```

is used to convert the output amplitude data into both its equivalent dB values and milliwatt power values. This function converts the dB amplitude values to milliwatt values by taking the inverse log of each amplitude value. This function also calls the RG11 .m file which subtracts the RG11 coax line loss giving the dB values and milliwatt values at the output of the low noise block amplifier.

Input arguments for function stage1 are defined as follows:

**Freq:** Freq is a frequency vector (incoming data values) in Hz.

**Amp:** Amp is the amplitude values (incoming data values) placed in an Amplitude matrix in dBm.

### 3. RG-11 Function

The following text is the source code for the RG11 Function developed for Matlab.

```
%function A=RG11(F,D,LO)
% Written by Paul Moose
function A=RG11(F,D,LO)
A=D.*(3.*(log10(F)-2)+2)/100+LO;
```

The function

```
A=RG11(F,D,LO)
```

calculates the insertion loss due to the transmission line (RG11 Coaxial Cable). The function returns the variable A which is the calculated loss in dB.

Input arguments for function RG11 are defined as follows:

**F:** Vector of frequencies in MHz.

**D:** Distance measured in feet.

**LO:** Other losses associated with connectors, adapters, and block capacitors in dB.

#### 4. Intpwr Function

The following text is the source code for the Intpwr Function developed for Matlab.

```
% Function[C,c] = intpwr(p, F1, F2, Fmhz, RESBW)
% Integrate Power in a specified Bandwidth
% Inputs: p is a matrix of powers in milliwatts
% F1 is a vector of lower frequencies in MHz
% F2 is a vector of corresponding upper frequencies in MHz
% Fmhz is a frequency vector in MHz for p.
% RESBW is the resolution bandwidth of the spectrum analyzer in MHz.
% Outputs: C is a matrix of band powers verses time in dBm
% c is the matrix in milliwatts
%
% Written by Paul Moose
function [C,c] = intpwr(p, F1, F2, Fmhz, RESBW)
delF = Fmhz(2) - Fmhz(1)
n1 = floor ((F1-Fmhz(1)*ones(1,length(F1)))/delF) +1
n2 = floor ((F2-Fmhz(1)*ones(1,length(F2)))/delF) +1

for k=1: length (n1)
    c(k, :) = sum(p(n1(k) : n2(k),:));
end
c = c*delF/RESBW;
C= 10*log10(c);
```

The function

```
[C,c] = intpwr(p, F1, F2, Fmhz, RESBW)
```

integrates the power in user specified bands. For example, the user could select the frequency bandwidth of 950 to 1050 MHz and this function would integrate the milliwatt power values and then convert the values back to dB.

Input arguments for function Intpwr are defined as follows:

**p:** p is a matrix of powers in milliwatts.

**F1:** F1 is a vector of lower user specified frequencies in MHz.

**F2:** F2 is a vector of corresponding upper specified frequencies in MHz

**Fmhz:** Fmhz are the frequency values for the rows of p.

**RESBW:** RESBW is the resolution bandwidth chosen during the recording of the data.

Outputs for the function Intpwr are:

**c:** c is the matrix in milliwatts.

**C:** C is a matrix of band powers verses time in dBm.



## V. DATA RESULTS

This chapter contains measured results for carrier power, background noise power, and average carrier power for the SBS-6, DVB, and DSS systems. Initially, each system's satellite signal is presented as plots of frequency (in Hz), versus amplitude (in dBm). Secondly, carrier power for specified transponders in each satellite signal are displayed graphically. Background noise power plots are also provided which display the noise level at the band edges of each signal. Lastly, calculated averages for carrier power and background noise levels for each system are provided and compared with estimated values addressed in Chapter II on pg. 20. The graphs and computed values in this section are made possible through the use of Matlab software.

### A. DSS SATELLITE SIGNAL

Figure 25 is a graphical display of the DSS satellite signal. This figure depicts the 18 Volt RHC polarization signal of the satellite.

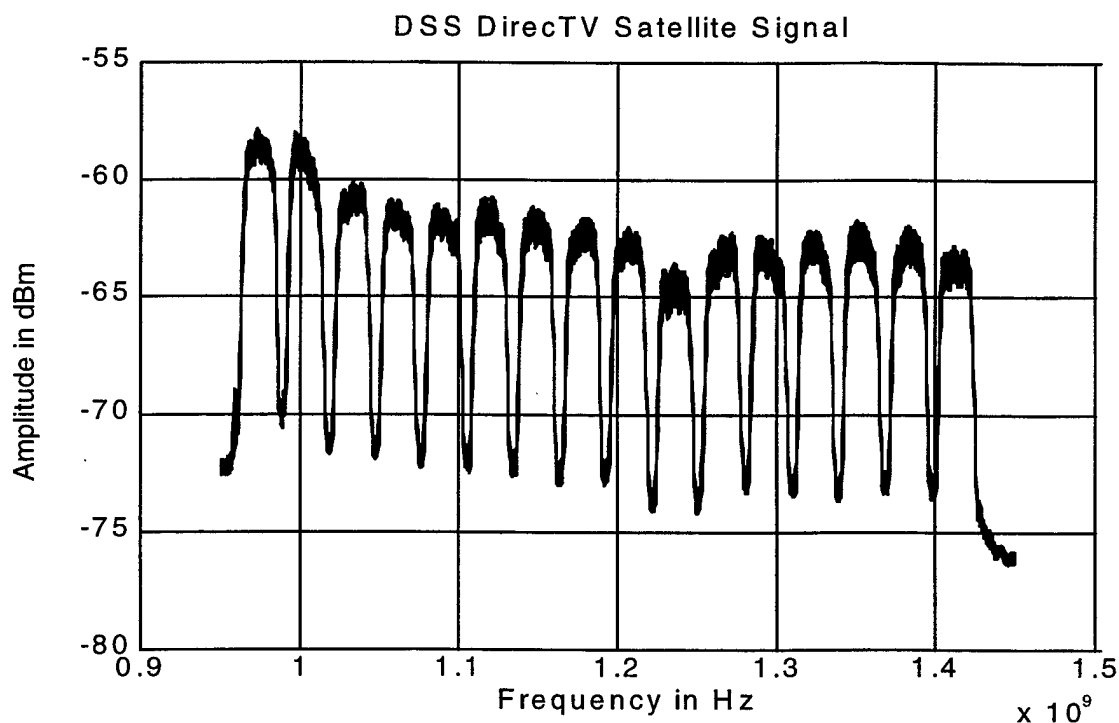

Figure 25. DSS Satellite Signal

The coded data rate for the DSS system is fixed at a value of 40 Mbps. Typical transmission rates are around 23 to 30 Mbps [Ref. 3]. Figure 26 is a graphical display of the carrier power (in dBm) verses time for DSS Channel 1 at 974 MHz and DSS Channel 16 at 1192.70 MHz.

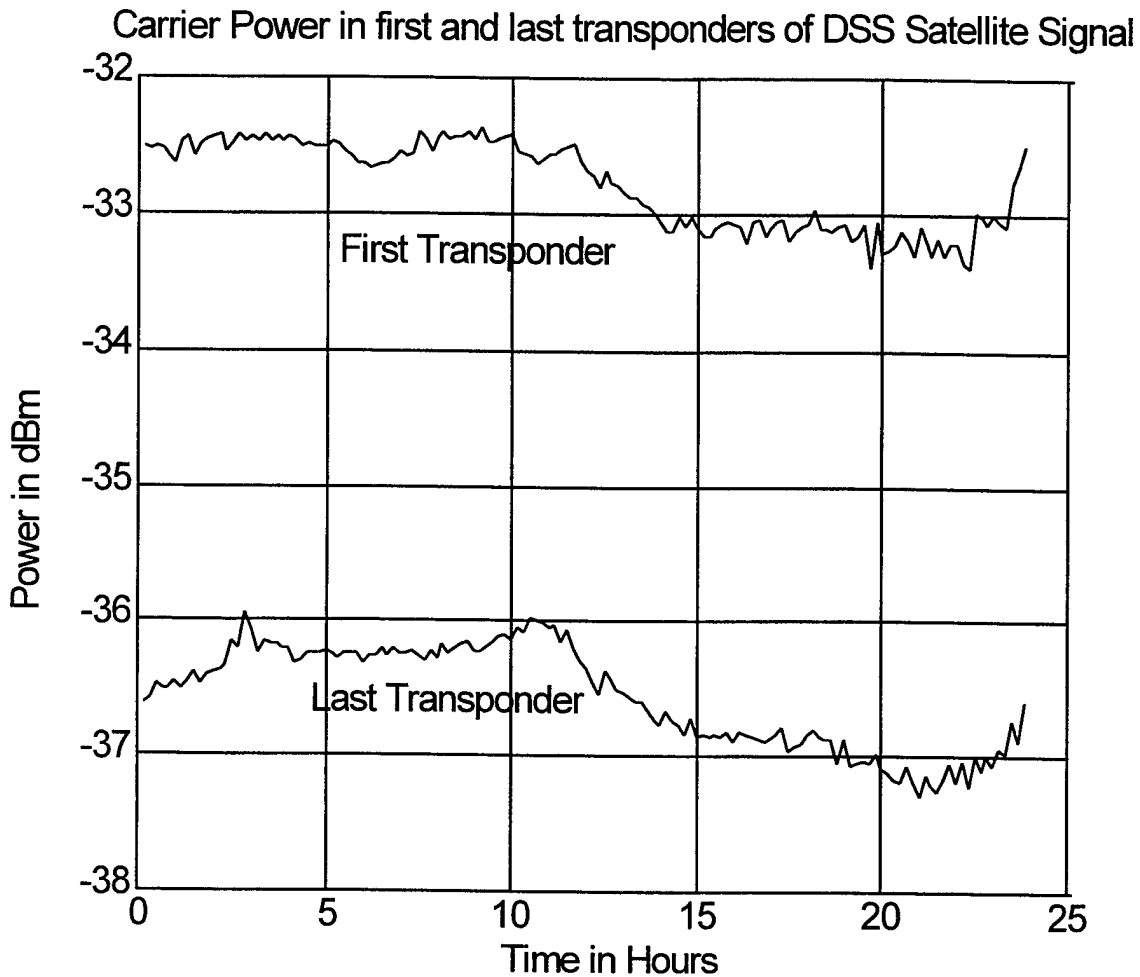

Figure 26. Carrier Power for DSS Channel 1 and 16 of the DSS Satellite Signal

Figure 26 is a plot of signal data recorded over a twenty-four hour period at ten minute intervals beginning at 1730 hours. Weather during these recordings was clear and sunny during the day, and clear skies at night. Notice the carrier power in the DSS Channel 1 is approximately equal to -32.50 dBm. DSS Channel 16 maintains a value of approximately -36.8 dBm. Of interest in both channels, is the apparent decrease in carrier power beginning at about 10 to 12 hours into the data recording. This might be attributed

to the warming effect on the receiver LNBS during sunrise. Future data analysis will attempt to address this phenomenon. For this recorded data, average (mean) carrier powers computed for the DSS signal over the twenty four period are -32.77 dBm in Channel 1, and -36.54 dBm in Channel 16.

Figure 27 displays the background noise power in the DSS signal. This is seen in figure 25 as the signal content to the left and right, of the first and last transponders (channel 1 and 16), respectively. The frequency bandwidth selected for measuring the background noise in the lower edge is 4 MHz wide (950 to 954 MHz). The bandwidth in the upper edge is 4 MHz wide (1440 to 1444 MHz).

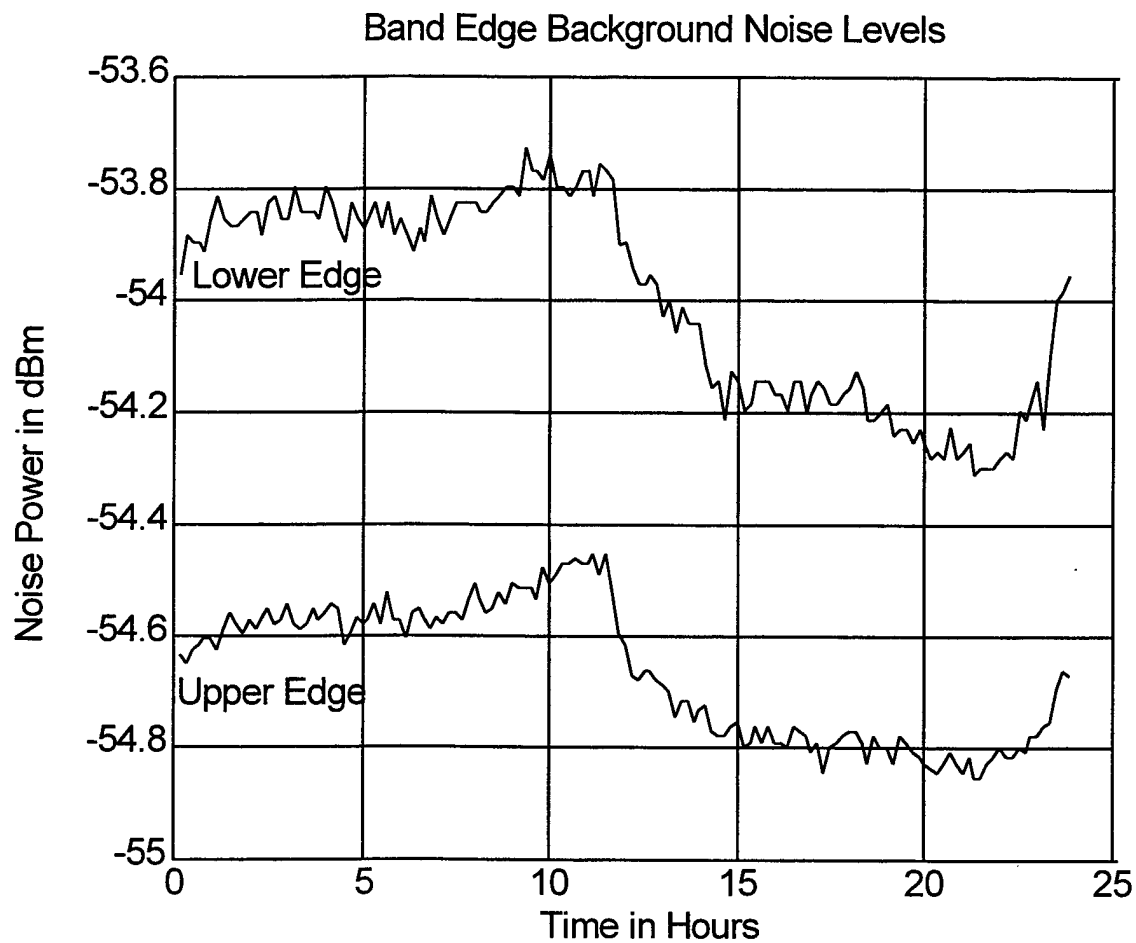

Figure. 27 Background Noise Levels for DSS Satellite Signal

Again, notice a drop in noise power at or about the 12 hour mark in the data recordings. The background noise power starts to increase in both the lower and upper edges at or at about the 22<sup>nd</sup> hour.

## B. DVB SATELLITE SIGNAL

Figure 28 is a graphical display of the DVB satellite signal. This figure depicts the 18Volt RHC polarization signal of the satellite.

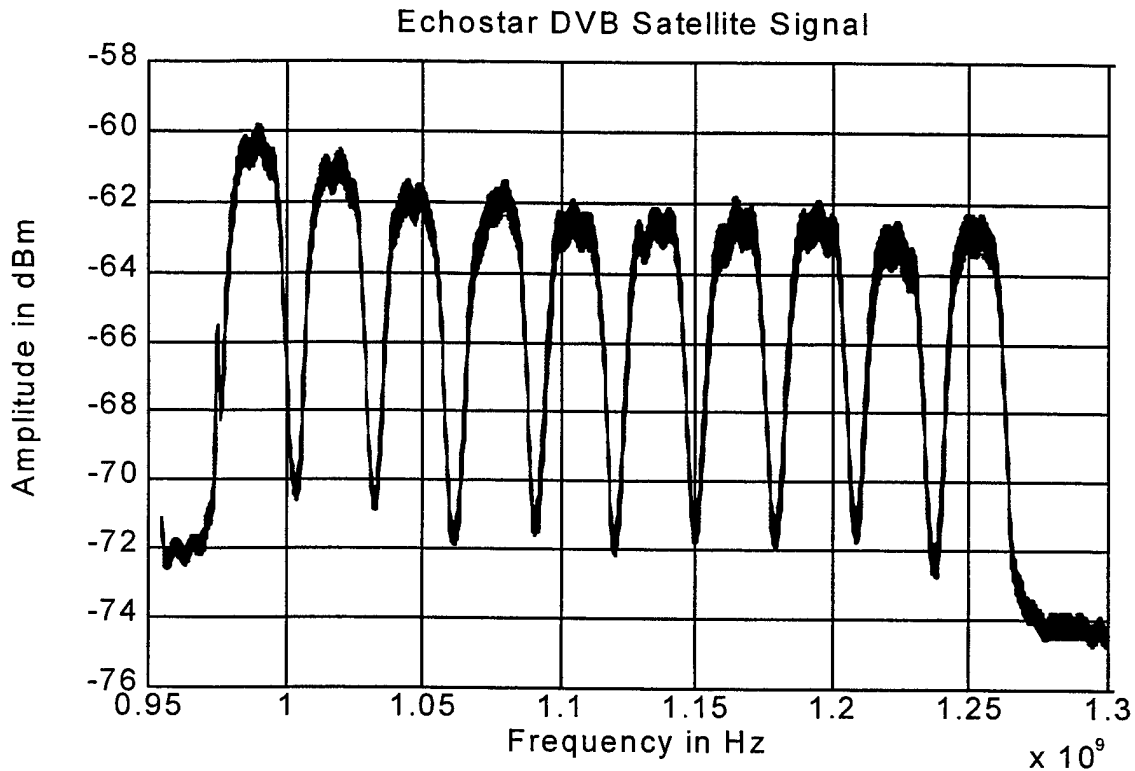

Figure 28. Echostar DVB Satellite Signal

The reader will note 10 separate transponders. The data rate associated with the DVB system is variable in nature; rates can be adjusted from 1 up to 50 Mbps [Ref. 3]. Figure 29 below is a graphical display of the carrier power (in dBm) versus time for DVB Channel 1 centered 975.77 MHz and DVB Channel 10 at 1252.22 MHz. The DVB recordings began at 1745 hours and were also made in clear sky conditions.

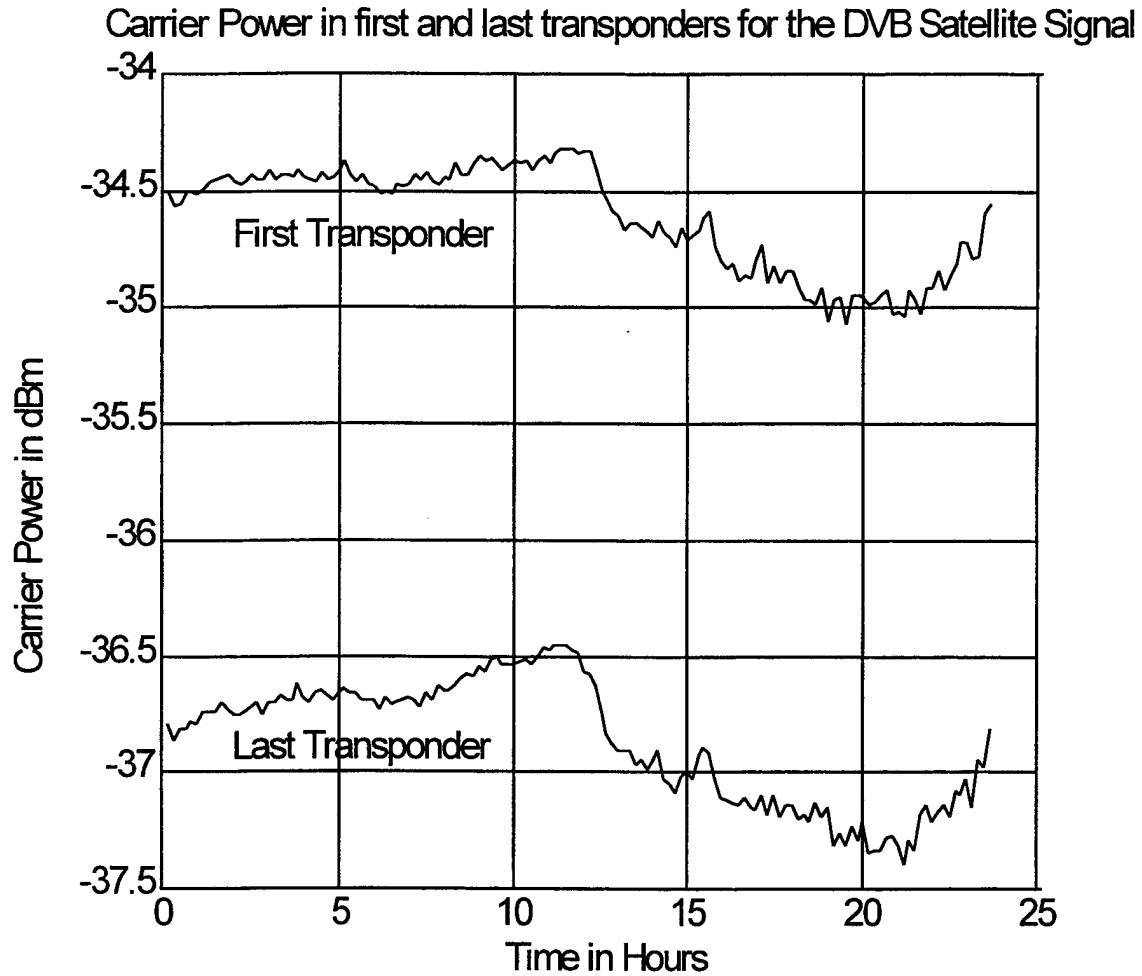

Figure 29. Carrier Power for DVB Channel 1 and 10 of the DVB Satellite Signal

The DVB signal also suffers a slight drop in the carrier power at or about the 12th hour. The drop in both transponders is roughly .3 dB. Average (mean) carrier powers computed for DVB Channel 1 and Channel 16 are -34.90 dBm and -36.45 dBm, respectively.

Figure 30 depicts the background noise power in the DVB signal. This is seen in figure 28 as the signal content to the left and right of transponders 1 and 10. The frequency bandwidth selected for measuring the background noise in the lower edge is 8 MHz wide (960 to 968 MHz). The bandwidth in the upper edge is 15 MHz wide (1280 to 1295 MHz).

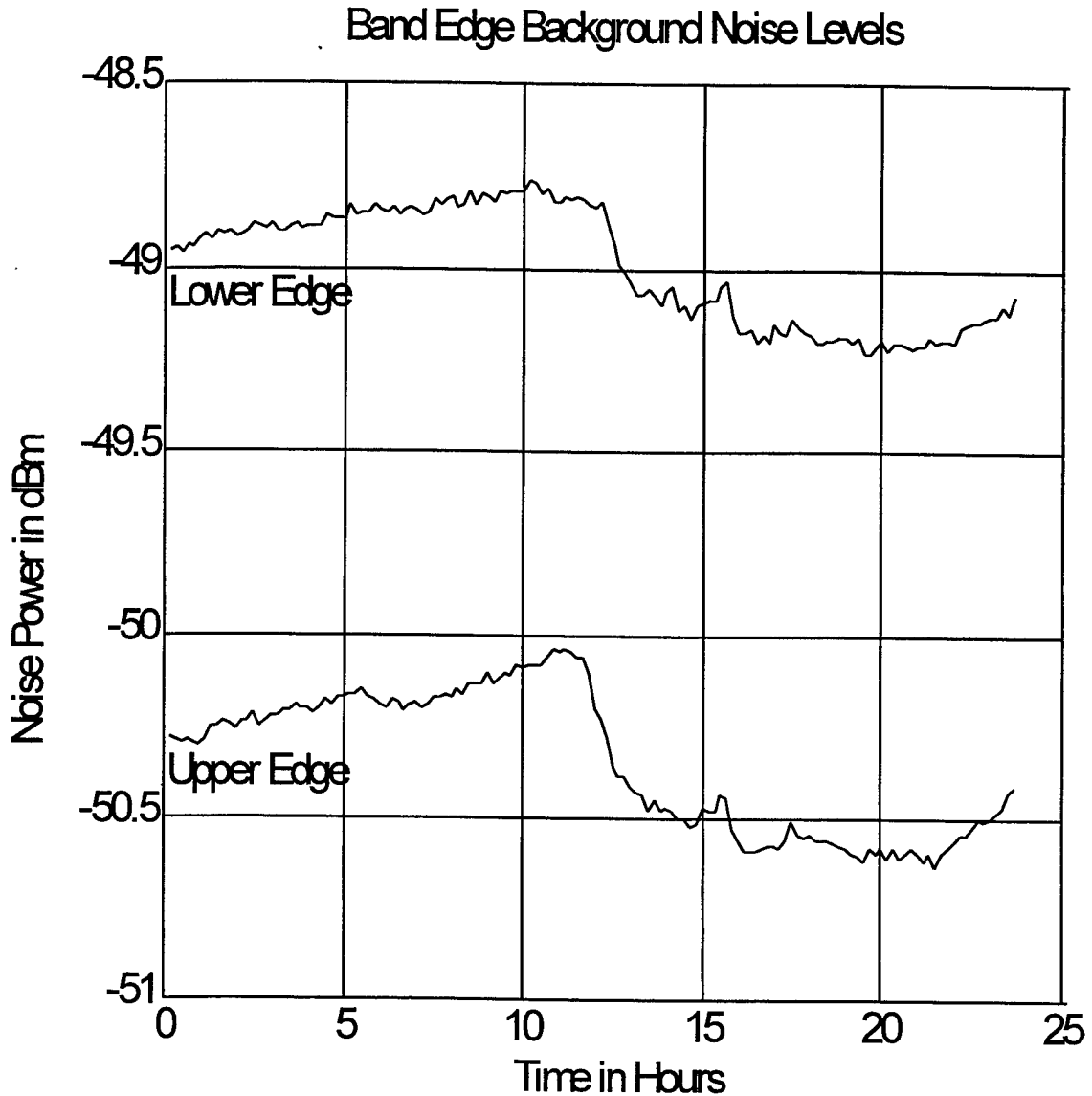

Figure 30. Background Noise Levels for the DVB Satellite Signal

### C. HUGHES SBS-6 SATELLITE SIGNAL

Figure 31 is a graphical display of the Hughes SBS-6 satellite signal. This graph represents the CONUS GBS broadcast signal and sends anywhere from 6 to 8 programs on a single transponder. The center frequency for the CONUS GBS transponder is 1367.67 MHz. The SBS-6 signal utilizes the DSS 40 Mbps waveform.

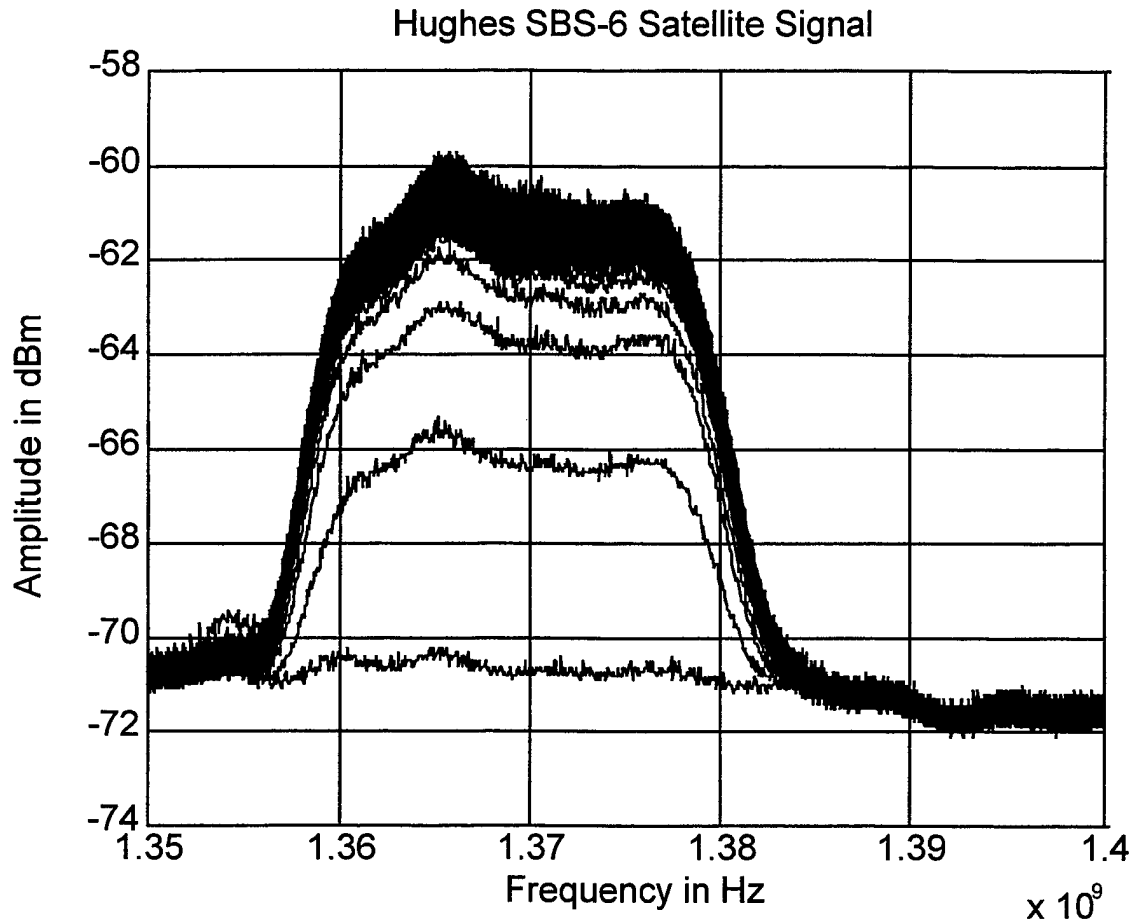

Figure 31. Hughes SBS-6 Satellite Signal

Figure 32 below displays the carrier power in the single SBS-6 transponder signal. Data recordings were taken over a 24 hour time period at 10 minute intervals beginning at 1800 hours. As seen in the graph, the carrier power is approximately -34.5 dBm.

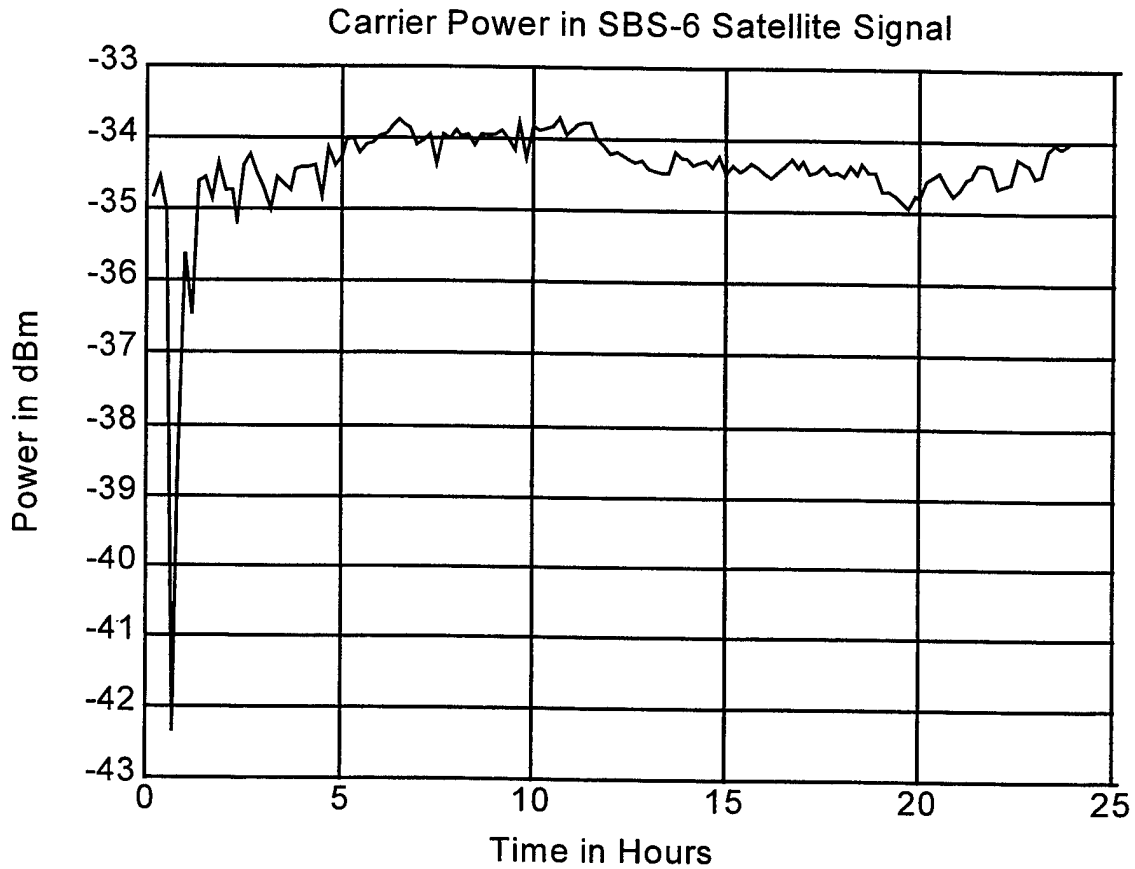

Figure 32. Carrier Power for Hughes SBS-6 Satellite Signal

Similar to the DSS and DVB signals, SBS-6 carrier power drops off slightly at or about the 12<sup>th</sup> hour. Notice the apparent transmitter down time near the beginning of the recording. This might be attributed to a pause in the transmission signal at the uplink facility or a power outage in the SSTL. Further recording of data will attempt to determine if this is a single incident or re-occurring.

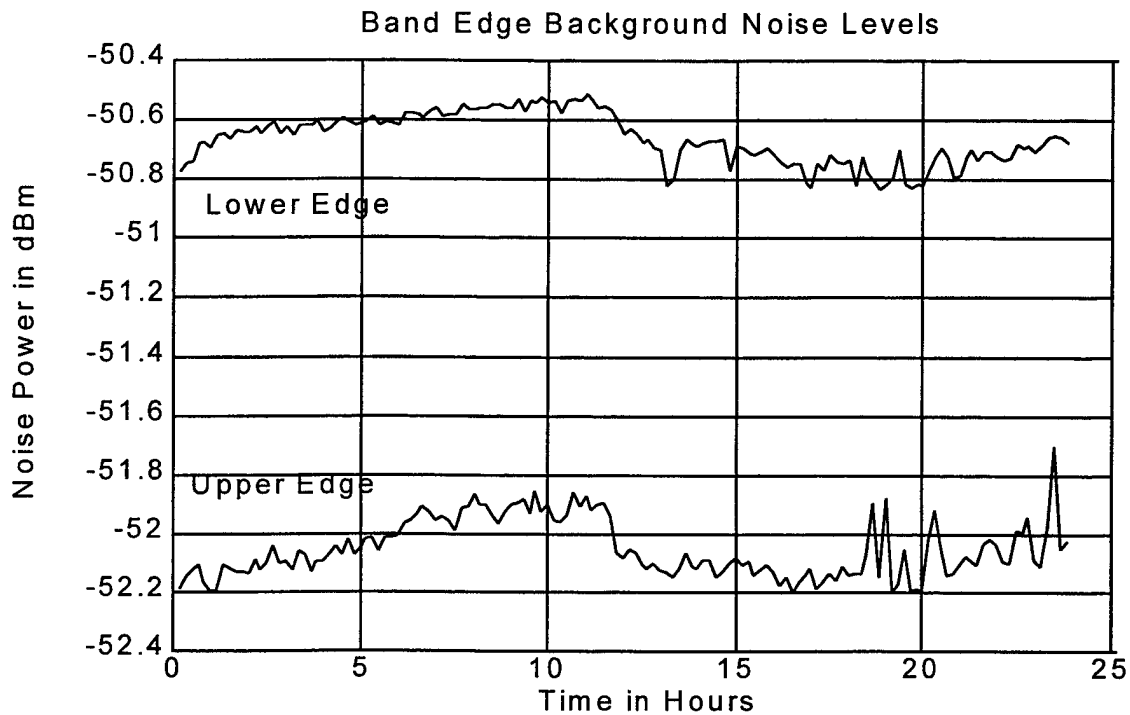

Figure 33. Background Noise Levels for the Hughes SBS-6 Satellite Signal

Figure 33 shows the background noise power present in the CONUS GBS SBS-6 signal. This is seen in figure 31 as the signal content to the left and right of the transponder. The frequency bandwidth selected for measuring the background noise in the lower edge is 3 MHz wide (1350 to 1353 MHz). The bandwidth in the upper edge is 5 MHz wide (1395 to 1400 MHz).

#### D. ANALYSIS

Table 6 displays the theoretical and measured values for carrier and noise powers specific to each system. Discussion of the results follows.

Theoretical versus Measured: Carrier and Noise Powers						
<i>Carrier Power</i>						
<u>System</u>		<u>Calculated Value</u>		<u>Measured Values</u>		
SBS-6		-29.41	dBm	Single Transponder	-34.28	dBm
DSS		-33.25	dBm	1st Transponder	-32.77	dBm
				2nd Transponder	-36.54	dBm
DVB		-39.01	dBm	1st Transponder	-34.9	dBm
				2nd Transponder	-36.45	dBm
<i>Noise Power</i>						
<u>System</u>		<u>Calculated Value</u>		<u>Measured Values</u>		
SBS-6		-118.33	dBm/Hz	Lower Edge	-116.82	dBm/Hz
				Upper Edge	-117.64	dBm/Hz
DSS		-132.62	dBm/Hz	Lower Edge	-120.01	dBm/Hz
				Upper Edge	-121.21	dBm/Hz
DVB		-123.04	dBm/Hz	Lower Edge	-119.02	dBm/Hz
				Upper Edge	-120.48	dBm/Hz

Table 9. Theoretical versus Measured: Carrier and Noise Powers

Comparison between estimated versus actual measured data provides interesting results. Using table 6 as a reference, a brief explanation of the compared results is provided below.

The SBS-6 signal (transponder centered at 1367.67 MHz), has an expected carrier power of -29.41 dBm. The measured value of -34.28 dBm indicates that the receive power is 4.87 dBm less than expected. Noise power measurements for the signal content in the frequency spectrums (1350 to 1353 MHz lower edge and 1395 to 1400 MHz upper edge) are -116.82 and -117.64 dBm respectively. The estimated noise power for SBS-6 at -118.33 dBm clearly indicates that there is no significant variation in the expected noise power versus the measured.

The estimated carrier power for the DSS signal is -33.25 dBm. DSS Channels 1 and 16 are centered at 974 MHz and 1192.70 MHz respectively, and have measured

carrier powers of -32.77 and -36.45 dBm. These results indicate that the measured carrier powers for these two transponders are nearly identical to the carrier power expected. Noise power measurements for the signal content in the frequency spectrums (950 to 954 MHz lower edge and 1440 to 1444 MHz upper edge) are -120.01 and -121.21 dBm respectively. The estimated noise power at -132.62 dBm indicates that there is higher background noise levels than expected (on the order of 11 dBm). Future study is required to determine exact cause of this variation.

The estimated carrier power for the DVB signal is -39.01 dBm. DVB Channels 1 and 10 are centered at 975.77 MHz and 1252.22 MHz respectively. Channel 1 has a measured carrier power of -34.9 dBm while Channel 10 is at -36.45 dBm. These results show that the measured carrier power is 4.11 dBm higher in Channel 1, and 2.56 dBm higher in Channel 10. Noise power measurements for the frequency spectrums 960 to 968 MHz lower edge and 1280 to 1295 MHz upper edge are -119.02 and -120.48 dBm respectively. The estimated noise power at -123.04 dBm indicates that the background noise levels measured are fairly consistent with the background noise levels expected.

Consistent among all three signals is a reduction in the carrier power with increasing frequencies. Notice in all three graphs of the signal spectrums (figures 25, 28, and 31) , the carrier powers are greater in the beginning transponders and weaker in the ending transponders which are at higher frequencies. The SBS-6 signal, although only one transponder, exhibits this behavior as well. Future study consistent with the GBS Testbed will address this issue.



## VI. SUMMARY

This thesis described the design of a satellite signal collection system for the NPS GBS Testbed. Most components used were those which were readily available or could be fabricated or programmed at a justifiable cost.

Initially, the focus was on identifying candidate hardware and software for the system. It was decided that all components would be chosen in view of how they could be implemented with LabVIEW. This was done so that data collection could be totally automated, requiring no attention from the operator while GBSTESTBED.VI was running. It has been determined that several hardware and software modifications to the system could enhance the data collection and analysis process. One such software improvement would be the ability to count and verify the number of samples recorded in LabVIEW. This can be accomplished through additional coding in the GBSTESTBED.VI and should be included so in the future. These improvements would ease data tracking and indexing. Other modifications could be made to GBSTESTBED.VI in regards to directory/file manipulation, such as enabling changes to be made from the front panel which would also be useful. Hardware modifications should include purchase of instrumentation devices that can accurately determine the gains of system hardware components such as low noise block amplifiers and antennas and implementation losses of IRDs. Additionally, it is strongly recommended that all instrumentation devices currently in the GBS Testbed inventory and those to be obtained in the future, be calibrated in accordance with manufacture specifications.

The purpose of this thesis was two fold. The first purpose was to develop and implement a data collection facility which would be simple and effective. The second purpose was to provide a base line assessment and measurement of signal carrier power and background noise levels for the three systems comprising the GBS Testbed. These objectives have been accomplished using available materials as outlined.



## APPENDIX A. CALCULATIONS OF RECEIVE ANTENNA ELEVATION ANGLES

### Antenna: Range, Elevation Angle to Satellite

<u>Naval Postgraduate School</u>		<u>Magnetic Variance</u>
Lat: 36°36' North	36.6 Decimal	(from aeronautical chart)
Long: 121°52' West	121.83 Decimal	15°15' East
		15.25 Decimal

Earth's Equatorial Radius  $r$ : 6378.16 Km

Height of Satellite Above Equator  $h$ : 35786.30 Km

The following Excel spreadsheet computes the antenna elevation angle in addition to the range from the Ground Antenna to the satellite:

DSS Antenna elevation angle and distance to satellite					
Freq in GHz	12.2			Radius of earth	6378
Satellite Longitude	101	w	1.762783	r	42164.2
Station Longitude	121.833	w	2.126387	LONG COMP	AW
Station Latitude	36.6	N	0.638791		
Elevation angle	42.18893	0.736336			
$\gamma$	0.722235	41.38102			
$\delta$	1.458472	83.56431			
E	0.736237	42.18328			
dsquared	1.41E+09				
distance	37615.64				
DVB Antenna elevation angle and distance to satellite					
Freq in GHz	12.2			Radius of earth	6378
Satellite Longitude	119	w	2.076942	r	42164.2
Station Longitude	121.833	w	2.126387	LONG COMP	AW
Station Latitude	36.6	N	0.638791		
Elevation angle	47.43798	0.827949			
$\gamma$	0.640434	36.69418			
$\delta$	1.468292	84.12696			
E	0.827858	47.43278			
dsquared	1.39E+09				
distance	37245.59				
SBS-6 Antenna elevation angle and distance to satellite					
Freq in GHz	12.2			Radius of earth	6378
Satellite Longitude	74	w	1.291544	r	42164.2
Station Longitude	121.833	w	2.126387	LONG COMP	AW
Station Latitude	36.6	N	0.638791		
Elevation angle	24.7191	0.43143			
$\gamma$	1.001634	57.38942			
$\delta$	1.432948	82.10186			
E	0.431313	24.71244			
dsquared	1.53E+09				
distance	39097.81				

The following equations are used in computing the distances from an antenna to a satellite and the receive antenna elevation angles:

### Range from Ground Receiver

$$(range(d))^2 = h^2 + 2r(r+h)(1 - \cos\phi\cos\lambda)$$

### Antenna Elevation Angle

$$\cos(elevation\angle) = (r+h/d)\sqrt{(1 - \cos^2\phi\cos^2\lambda)}$$

These formulas are programmed into the spreadsheet for quick computation of distance and elevation angles for a given satellite system.

## APPENDIX B. CALCULATION OF TOTAL SYSTEM NOISE LEVELS

### Satellite Receive System G/T (Figure of Merit) for 1 Meter Dish (SBS-6):

<u>Antenna</u>	<u>LNB</u>	<u>Lossy Line</u>
$G_a = 39.54 \text{ dB}$	$G_{\text{lnb}} = 62.0 \text{ dB}$	$L_{\text{line}} = 12.8 \text{ dB}$
$g_a = 8994.97$	$g_{\text{lnb}} = 1584893.19$	$l_{\text{line}} = 19.05$
$T_{\text{sky}} = 9^\circ \text{ K}$	$\text{NF} = .8 \text{ dB}$ $nf = 1.20$	$g_{\text{line}} = .01905460717$
	$T_{e_{\text{lnb}}} = T_o(nf-1)$	$T_{e_{\text{line}}} = T_o(l_{\text{line}} - 1)$
	$T_{e_{\text{lnb}}} = 290(1.20-1)$	$T_{e_{\text{line}}} = 290(19.05-1)$
	$T_{e_{\text{lnb}}} = 58^\circ \text{ K}$	$T_{e_{\text{line}}} = 5234.5$

$$G_{\text{net}} = G_a = 39.34 \text{ dB}$$

$$T_{\text{ant}} = T_{\text{sky}} = 9^\circ \text{ K}$$

$$T_{\text{rec}} = T_{\text{lnb}} + (T_{e_{\text{line}}} / g_{\text{lnb}})$$

$$T_{\text{rec}} = 58^\circ + (5234.5 / 1584893.19)$$

$$T_{\text{rec}} = 58^\circ + .003302746$$

$$T_{\text{rec}} = 58.003$$

$$T_{\text{sys}} = T_{\text{ant}} + T_{\text{rec}}$$

$$T_{\text{sys}} = 9^\circ + 58.003$$

$$T_{\text{sys}} = 67.003$$

$$G/T = G_{\text{net}} - 10\log_{10}(T_{\text{sys}})$$

$$G/T = 39.34\text{dB} - 10\log_{10}(67.003)$$

$$G/T = 21.07 \text{ dB/K}$$

**Satellite Receive System G/T (Figure of Merit) for .45 Meter Dish (DSS):**

Antenna

$$G_a = 33.19 \text{ dB}$$

$$g_a = 2084.49$$

$$T_{\text{sky}} = 9^\circ \text{ K}$$

LNB

$$G_{\text{lnb}} = 56.0 \text{ dB}$$

$$g_{\text{lnb}} = 398107.17$$

$$\text{NF} = 1.46 \text{ nf} = 1.40$$

$$T_{e_{\text{lnb}}} = T_o(\text{nf}-1)$$

$$T_{e_{\text{lnb}}} = 290(1.40 - 1)$$

$$T_{e_{\text{lnb}}} = 116^\circ \text{ K}$$

Lossy Line

$$L_{\text{line}} = 12.8 \text{ dB}$$

$$l_{\text{line}} = 19.05$$

$$g_{\text{line}} = .01905460717$$

$$T_{e_{\text{line}}} = T_o(l_{\text{line}} - 1)$$

$$T_{e_{\text{line}}} = 290(19.05-1)$$

$$T_{e_{\text{line}}} = 5234.5$$

$$G_{\text{net}} = G_a = 33.19 \text{ dB}$$

$$T_{\text{ant}} = T_{\text{sky}} = 9^\circ \text{ K}$$

$$T_{\text{rec}} = T_{\text{lnb}} + (T_{e_{\text{line}}} / g_{\text{lnb}})$$

$$T_{\text{rec}} = 116 + (5234.5 / 251188.643)$$

$$T_{\text{rec}} = 116 + .020838919$$

$$T_{\text{rec}} = 116.020$$

$$T_{\text{sys}} = T_{\text{ant}} + T_{\text{rec}}$$

$$T_{\text{sys}} = 9^\circ + 116.020$$

$$T_{\text{sys}} = 125.02$$

$$G/T = G_{\text{net}} - 10\log_{10}(T_{\text{sys}})$$

$$G/T = 33.19\text{dB} - 10\log_{10}(125.02)$$

$$G/T = 12.221 \text{ dB/K}$$

**Satellite Receive System G/T (Figure of Merit) for .45 Meter Dish (EchoStar DVB):**

Antenna

$G_a = 33.19 \text{ dB}$   
 $g_a = 2084.49$   
 $T_{\text{sky}} = 9^\circ \text{ K}$

LNB

$G_{\text{lnb}} = 56.0 \text{ dB}$   
 $g_{\text{lnb}} = 398107.17$   
 $\text{NF} = 1.1 \text{ nf} = 1.28$   
 $T_{e_{\text{lnb}}} = T_o(\text{nf}-1)$   
 $T_{e_{\text{lnb}}} = 290(1.28-1)$   
 $T_{e_{\text{lnb}}} = 81.2^\circ \text{ K}$

Lossy Line

$L_{\text{line}} = 12.8 \text{ dB}$   
 $l_{\text{line}} = 19.05$   
 $g_{\text{line}} = .01905460717$   
 $T_{e_{\text{line}}} = T_o(l_{\text{line}} - 1)$   
 $T_{e_{\text{line}}} = 290(19.05-1)$   
 $T_{e_{\text{line}}} = 5234.5$

$G_{\text{net}} = G_a = 33.19 \text{ dB}$   
 $T_{\text{ant}} = T_{\text{sky}} = 9^\circ \text{ K}$

$T_{\text{rec}} = T_{\text{lnb}} + (T_{e_{\text{line}}} / g_{\text{lnb}})$   
 $T_{\text{rec}} = 81.2 + (5234.5 / 398107.17)$   
 $T_{\text{rec}} = 81.2 + (.013148469544)$   
 $T_{\text{rec}} = 81.21$

$T_{\text{sys}} = T_{\text{ant}} + T_{\text{rec}}$   
 $T_{\text{sys}} = 9^\circ + 81.21$   
 $T_{\text{sys}} = 90.21$

$G/T = G_{\text{net}} - 10\log_{10}(T_{\text{sys}})$   
 $G/T = 33.19\text{dB} - 10\log_{10}(90.21)$   
 $G/T = 13.63\text{dB/K}$



## LIST OF REFERENCES

1. GBS Concepts of Operation, USSSPACECOM, pg. 2, 25 January 1996.
2. Paul H. Moose and John A. Watkins, *Global Broadcast Service Research at the Naval Postgraduate School*, White Paper, Naval Postgraduate School, Monterey, California, November, 1996.
3. Robert Carlisle, *A Global Broadcast Service for the User on the Move*, Master's Thesis, Naval Postgraduate School, Monterey, California, September 1996.
4. G. Gordon and W. Morgan, *Principles of Communications Satellites*, Chapter 1, John Wiley and Sons, Inc., 1993.
5. G. Gordon and W. Morgan, *Principles of Communications Satellites*, Chapter 9, John Wiley and Sons, Inc., 1993.
6. Keith Schaffler, *The Design and Installation of a Global Broadcast Service Demonstration Project at the Naval Postgraduate School*, Master's Thesis, Naval Postgraduate School, Monterey, California, March 1997.
7. Stephen Scotty, *Expected Performance of the Global Broadcast Service Phase II with emphasis on Environmental Limitations to Supportable Data Rates*, Naval Postgraduate School, Monterey, California, June 1997.
8. Telecommunications Technique Corporation, *Fireberd 6000 User's Manual*, March 1995 Edition.
9. Hewlett-Packard, *HP8568B Spectrum Analyzer Operating and Programming Manual*, Chapter 1, March 1984 Edition.
10. National Instruments, *LabVIEW Graphical Programming for Instrumentation User's Manual*, January 1996 Edition.
11. The Math Works Inc., *MATLAB User's Guide Version 4*, 1995 Edition.
12. National Instruments, *LabVIEW Function Reference Manual Version 3.0*, August 1993 Edition.



## INITIAL DISTRIBUTION LIST

	No. Copies
1. Defense Technical Information Center..... 8725 John J. Kingman Road, STE 0944 Ft. Belvoir, VA 22060-6218	2
2. Dudley Knox Library..... Naval Postgraduate School 411 Dyer Road Monterey, CA 93943-5101	2
3. Professor Paul H. Moose..... Naval Postgraduate School Code EC/ME Monterey, CA 93943	2
4. Professor Carl R. Jones..... Naval Postgraduate School Code SM/JS Monterey, CA 93943	1
5. CAPT Joseph Delpino..... GBS/JPO care of DISA D216 C4&I Programs Directorate Skyline 5 5111 Leesburg Pike Falls Church, VA 22041-3205	1
6. Dr. Roy Axford Jr..... NCCOSC RDTE DIV 841 53560 Hull St. San Diego, CA 92152-5001	1
7. CDR Ben Roper..... J6S Room 1C826 Pentagon Washington D.C. 20301	1

- 8. LT John A. Watkins ..... 2  
106 Malloway Ln.  
Monterey, CA 93940
  
- 9. Dr. Sherman Gee ..... 1  
ONR Code 313  
800 N. Quincy St.  
Arlington, VA 22217