

WHOI-97-16

**Woods Hole
Oceanographic
Institution**

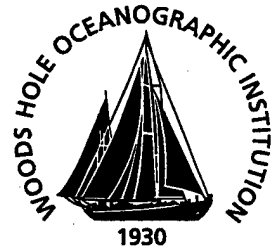

**Design and Evaluation of a Directional Antenna
for Ocean Buoys**

by

Daniel Frye, Ken Doherty, and Al Hinton

November 1997

Technical Report

Funding was provided by Viasat, Inc., under subcontract No. SC95001 and by a Cecil H. and Ida M. Green Technology Innovation Award.

Approved for public release; distribution unlimited.

DTIC QUALITY INSPECTED 8

19980223 125

WHOI-97-16

**Design and Evaluation of a Directional Antenna
for Ocean Buoys**

by

Daniel Frye, Ken Doherty, and Al Hinton

**Woods Hole Oceanographic Institution
Woods Hole, Massachusetts 02543**

November 1997

Technical Report

Funding was provided by Viasat, Inc., under subcontract No. SC95001 and by a Cecil H. and Ida M. Green Technology Innovation Award.

Reproduction in whole or in part is permitted for any purpose of the United States Government. This report should be cited as Woods Hole Oceanog. Inst. Tech. Rept., WHOI-97-16.

Approved for public release; distribution unlimited.

Approved for Distribution:

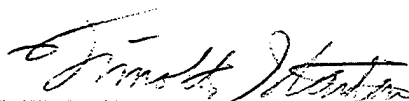

Timothy Stanton, Chair

Department of Applied Ocean Physics and Engineering

DTIC QUALITY INSPECTED 3

TABLE OF CONTENTS

ABSTRACT	3
ACKNOWLEDGMENTS	4
1.0 INTRODUCTION	5
1.1 Background	5
1.2 Conceptual Approach	6
1.3 Objectives	8
2.0 TECHNICAL APPROACH	9
2.1 Antenna Design	9
2.2 Mechanical Steering System Design	12
3.0 TEST RESULTS	17
3.1 Test Results with Rotating Table	17
3.2 Test Results with Tilted Rotating Table	25
4.0 DISCUSSION	25
5.0 REFERENCES	29
6.0 APPENDIX	30

DESIGN AND EVALUATION OF A DIRECTIONAL ANTENNA FOR OCEAN BUOYS

ABSTRACT

A system concept has been developed by Viasat, Inc. and Woods Hole Oceanographic Institution for improving the data telemetry bandwidth available on ocean buoys. This concept utilizes existing communications satellites as data relay stations and mechanically steered antenna arrays to achieve increased data rates and improved power efficiency needed for ocean applications.

This report describes an initial feasibility and design study to determine if a mechanically steered antenna array can meet the requirements of open ocean buoy applications. To meet the system requirements, an 18-element microstrip antenna (9-element transmit, 9-element receive) was designed and fabricated under subcontract by Seavey Engineering Associates, Inc. It operates in the 4-6 GHz frequency band (C-band) and provides 14 dB of gain. The $\frac{1}{2}$ power beamwidth is $\pm 15^\circ$ in azimuth and elevation. This antenna design, in conjunction with a simple rotating mount, was used to evaluate the potential of this approach to keep a geostationary satellite in view when mounted on an ocean buoy. The evaluation is based on laboratory measurements using a magnetic compass and a small stepper motor to maintain antenna orientation while the complete assembly was rotated and tilted at speeds similar to what would be expected on an offshore buoy equipped with a stabilizing wind vane.

The results are promising, but less than conclusive because of limitations in the experimental test setup. The recent introduction of several commercially available mechanically steered antennas designed for use on small boats may provide a viable alternative to the approach described here with appropriate modification to operate at C-band.

ACKNOWLEDGMENTS

The project was funded jointly by Viasat, Inc. of Carlsbad, CA, under subcontract No. SC95001 and a Cecil H. And Ida M. Green Technology Innovation Award provided by the Woods Hole Oceanographic Institution. Tom Hurst performed the data collection for the rotating table experiments and Paul Medeiros of Seavey Engineering Associates, Inc. designed the directional antenna array. Ken Gamache of Viasat, Inc. provided valuable technical insight for the antenna design.

1.0 INTRODUCTION

1.1 Background

One of the continuing challenges in oceanography is the development of practical and cost effective techniques to collect oceanographic data in real time [1]. In particular the ocean's interior is poorly sampled in time and space and real-time data are especially difficult to obtain. One of the major limitations in this endeavor is available bandwidth on satellite communication systems with oceanic coverage. Historically, ocean researchers have used the Argos [2] and GOES [3] systems for ocean data telemetry, but they have very limited bandwidth. They do, however, provide global coverage and generally meet the power constraints of most ocean platforms. A number of other satellite telemetry options have recently become available or are in the advanced planning stages. Some of these have limited spatial coverage and others are limited by data throughput or access charges, but several have the potential to revolutionize ocean data collection [4].

The general categories into which these systems fall are the Little LEOs, Big LEOs, and geostationary systems [5]. Little LEOs are Low Earth Orbit systems aimed at low-rate data transfer. They generally consist of a few to up to three dozen small satellites that link small, low-power transceivers anywhere on the earth to a few base stations located at strategic positions around the globe. The Orbcomm system is the most advanced of the Little LEO systems. It is designed to provide global data transfer using relatively short messages for a very large number of users. It utilizes the 130-150 MHz band and requires 5 watt transmitters combined with omni-directional antennas. At this time, Orbcomm has two satellites in place with a planned constellation of thirty six. An experimental test of the Orbcomm system on the R/V KNORR [6] resulted in data throughput of only about 1 Kbyte/day (similar to Argos), but as more satellites are launched, this number may increase though throughput per platform is a function of the number of platforms in use as well as the number of satellites in orbit. In addition, the tariffs associated with tens of Kbytes per day data transfer may not be affordable. However, final tariffs have not yet been announced. The long-term outlook for Orbcomm is driven by the market for data transfer services, and whether a market for data-only messaging is a distinct niche not covered by the Big LEOs is still uncertain.

Big LEO systems, which operate at L-band (1.6 - 2.5 GHz) are probably best represented by the Iridium system which plans to launch sixty-six satellites in Low Earth Orbit to provide worldwide satellite cellular telephone service. This system, or one of its several potential competitors (GlobalStar and Odyssey are examples of U.S. based competitors) is likely to be operational before the Year 2000. Iridium also requires a 5 watt transceiver using an omni-directional antenna at the remote sites. It supports 2400 bit/s data rates and is expected to charge on the order of \$3.00 per minute, which is far less than Argos or proposed Orbcomm tariffs. It should be noted that predicted rates are frequently the lower price bound and that typically rates rise as a system gets closer to implementation. Questions about Iridium center on whether it will support true global access and, of course, whether it will prove to be commercially viable.

Several of the competing Big LEO systems are designed primarily for coverage of populated areas and these systems require fewer and less sophisticated satellites than Iridium. Whether this technical difference will have a profound impact on which system or systems survive into the next century is unknown, but some of the competing approaches provide only limited ocean coverage.

The third general approach to ocean data telemetry utilizes geostationary satellites. GOES is an example of a geostationary system that has been operational since the 1970s. The disadvantage of the geostationary systems for battery powered operation is that they require substantially more power at the remote sites to reach the satellites which are about 36,000 km from the surface of the earth, while the LEOs are typically at altitudes of 800-1400 km. Thus, geostationary systems with omni-directional antennas typically require 40-50 watts of transmitted power to achieve data rates that the LEOs can achieve with 1-5 watt transmitters. The GOES system was developed for U.S. government use in the 1970s and is limited to a few Kbytes data throughput per day per transmitter. InMarsat C, the other operational system in this category, is normally used for short messages, though its base data rate is 600 bit/s. A new service offered by Westinghouse using the MSAT satellite system can provide telephone quality service (2400 bit/s) using a 20-40 watt transmitter and a mechanically steered antenna array [7]. This approach, which has just recently become operational, is similar in some respects to the Viasat/WHOI concept and is available for ocean areas near the U.S. and Central America. It has not been used on ocean buoys to date, but is designed specifically for small boats and should be transferable to large ocean buoys. Several groups are evaluating this system, called SKYSITE, at this time [8] and [9]. The hardware to implement the SKYSITE link is too large and power consumptive for many ocean buoy applications. Unanswered questions concerning interference with InMarsat in coastal waters may also limit the utility of the system.

The above discussion is not meant to be an in-depth treatment of mobile satellite communications. It is meant to provide some context to the discussion in the following section. A more complete description of the field can be found in [4], [10], and [11] and in the referenced material in these articles.

1.2 Conceptual Approach

The key issues in identifying and developing practical approaches for ocean data telemetry include:

1. Coverage - Systems with global or nearly global coverage are needed to monitor the 70% of the globe that is water covered. In some applications short range systems such as line-of-sight radio or cellular telephone can provide very good solutions incorporating low cost, high data rates, and high reliability. In these cases a satellite-based system is not required. Beyond 10 or 20 miles, however, these systems begin to have propagation problems unless antennas can be placed at high elevations. A second category of coverage is less than global, but provides important oceanic coverage in waters near the coast. Some of these systems, which are targeted on continental land mass areas, cover

significant fractions of the Atlantic and Pacific oceans. The Westinghouse SKYSITE system is an example of this important class for North American oceanographers and similar systems are likely to become available in Europe. They use spot beams from geostationary satellites to concentrate their resources where their customers are.

2. Data Throughput - Oceanographers need a range of data rates - from a few bytes per day in some cases to Mbytes per second in other cases. The typical rates available at present are one to a few Kbytes per day. Most real-time applications would be satisfied by 2400 bit/s on a bursting basis with the duty cycle determined by power considerations, cost per bit, and importance of the data. This is the rate nominally available from systems providing telephone service. Two-way data telemetry is a key feature of the systems presently being implemented.
3. Cost - Typical Argos costs are \$4,000/year per platform. Data costs in this range or perhaps up to 10 times this amount, on a per site basis, are typical limits in the oceanographic community. Obviously, for short term, high visibility applications, higher fees may be acceptable. Hardware cost is less of an issue since the transceivers for most of these systems are in the \$1,000 - \$5,000 range.
4. Power - Data rates are intimately tied to transmit power and antenna configuration. Higher gain antennas infer higher data rates at a given transmit power, but steered antennas also infer power usage to provide steering. Most oceanographic applications operate on batteries where continuous drains exceeding a few watts are unacceptable except for short-term applications. A solar panel array can increase this limit by a factor of 5-10 in areas with lots of sunshine. A reasonable goal for an oceanographic system limits the average power drain to 1 watt or less and the maximum drain to 50 watts or less to avoid special constraints on battery design.

Ken Gamache of Viasat, Inc. has developed a proprietary conceptual design for a satellite telemetry system taking into account the complex interaction between the requirements and limitations of ocean data telemetry systems. In general outline, the proposed Viasat system operates as follows:

A C-band (4-6GHz) transceiver is deployed on an ocean buoy. Its receiver is able to lock on the downlink from a commercial C-band communications satellite on which bandwidth has been leased. (These lease rates are low relative to the throughput potential for ocean data telemetry). The transmitter is tuned to 6 GHz, the receiver to 4 GHz. To reach the geostationary C-band satellite, a directional antenna with 14 dB of gain is used. At 5 watt transmit level, a data rate of 250 bit/s can be achieved. Because pointing accuracy is variable, a spread-spectrum transmission scheme is used to minimize interference on nearby satellites. This interference issue also dictates a maximum output of 5 watts at the transmitter. The satellite acts as a bent pipe and the data are collected by a Viasat ground station. Data can also be received by the offshore buoy. A more complete description of the Viasat approach can be found in [12].

The WHOI contribution to the system is the mechanically-steered antenna array. An 18-element microstrip antenna array provides 14 dB of gain in transmit and receive with a conical beam pattern of $\pm 15^\circ$ in azimuth and elevation (at the $\frac{1}{2}$ power point - HPBW). The width of the beam pattern is designed to keep the satellite in view of the transceiver during most sea conditions as the buoy moves in response to waves. Buoy heave (vertical displacement) and translation (horizontal displacement) are not an issue. Antenna pointing in azimuth is accomplished by monitoring buoy orientation relative to magnetic north using a triaxial magnetometer (compass). The antenna is mounted on a platform that is rotated in azimuth to keep it pointed in the direction of the satellite. Compass measurements are corrected for buoy tilt using a built in tilt sensor.

1.3 Objectives

The goal of the buoy telemetry system is to transmit data to and from most ocean locales at rates up to 250 bit/s using less than 15 watts total power. Tariffs for delivered data have the potential to be as low as \$0.10 /Kbyte. Cost to implement the system is a small fraction of other systems since a dedicated space segment is not required and costs of the transceiver/antenna are similar to most other approaches. The buoy telemetry system would be developed for specific groups of users in specific industries. This is probably both a strength and a weakness of the approach. The reason the Iridium system has the potential to provide cost effective ocean data telemetry is that it is aimed at a very large market for worldwide telephone service. This keeps costs low, but means that oceanographers could be left out, if ocean coverage is not supported. The Viasat approach would have to support itself on a smaller base of users, but it could be more responsive to their needs in a way that Iridium never could.

The objective of the WHOI portion of the research was to develop a design for a mechanically-steered, directional antenna that would meet the requirements of an offshore buoy application in terms of size, power, cost, and buoy dynamics. The design has to provide the RF features needed for the transceiver, i.e., 14 dB gain, reasonable pointing accuracy and 4/6 GHz receive/transmit frequencies. Rather than limit the work to a purely theoretical analysis of these systems, we chose to design and fabricate a prototype system that we could test on a simple laboratory apparatus to measure its performance and thus gain insight into the practical problems associated with our approach. Sections 2 and 3 describe the prototype design and the test results. Section 4 provides a discussion of the results and some insight into how recent commercial developments have impacted the work.

2.0 TECHNICAL APPROACH

2.1 Antenna Design

The requirements of the mechanically-steered buoy antenna system are:

Gain: 14 dB - Transmit and receive

Directionality: $\pm 15^\circ$ in elevation and azimuth at the HPBW

Pointing accuracy: $\pm 1^\circ$ in azimuth under stable conditions
 $\pm 15^\circ$ under typical sea state conditions

Response time: $\geq 20^\circ/\text{sec}$ in azimuth

Size: $\leq 30 \text{ cm} \times 30 \text{ cm}$

Weight: $\leq 1 \text{ kgm}$

These requirements were based on the RF requirements of the satellite link, the physical dimensions of ocean buoys, and the dynamic motions of ocean buoys in normal sea states. The objective was a system that would operate reliably up to Sea State 4 or 5 and perhaps higher depending on buoy design. A key question about the effect of momentary outages when the antenna beam is pointing away from the satellite is yet to be answered. The presumption is that, like other systems, once the receiver has achieved lock and a transmission has begun, momentary dropouts can be accommodated without significant penalties in data throughput. Obviously, some means of error correction or re-transmission will be required in these cases, but these details concerning system protocols have not been addressed.

To meet the antenna requirements, a subcontract with Seavey Engineering Associates, Inc., of Cohasset, MA was put in place to design and fabricate two C-band antennas. The initial subcontract with Seavey used a preliminary specification on the antenna beam pattern. In this early design we requested that they produce an asymmetrical beam pattern that was $\pm 6^\circ$ in azimuth and $\pm 20^\circ$ in elevation (at the HPBW) with 17 dB of gain for the transmit array and $\pm 12^\circ$ in azimuth, $\pm 20^\circ$ in elevation with 14 dB of gain for the receive array. Figure 1 shows the antenna which was produced. Its beam pattern, as measured by Seavey's engineers was

Transmit (6 GHz): $\pm 6^\circ$ azimuth, $\pm 16^\circ$ elevation, 17 dB gain

Receive (4 GHz): $\pm 8.5^\circ$ azimuth, $\pm 20^\circ$ elevation, 14 dB gain

After working with this design, it was determined that a symmetric array would be more readily modeled and would probably provide better results on an ocean buoy. As a consequence, Seavey designed and fabricated a second antenna with the following beam pattern:

Transmit/Receive: $\pm 15^\circ$ azimuth and elevation, 14 dB gain

Figure 2 shows the second antenna design and Table 2 (from [13]) shows the results of the engineering tests.

Rx & Tx Radiating Elements
and
Feed Networks

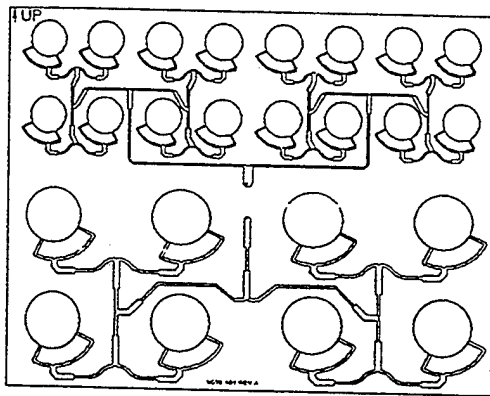

Rx & Tx Parasitic Arrays

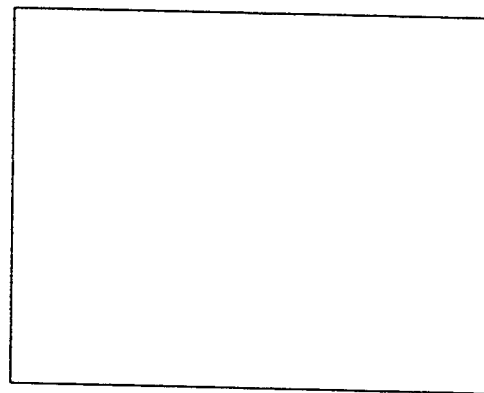
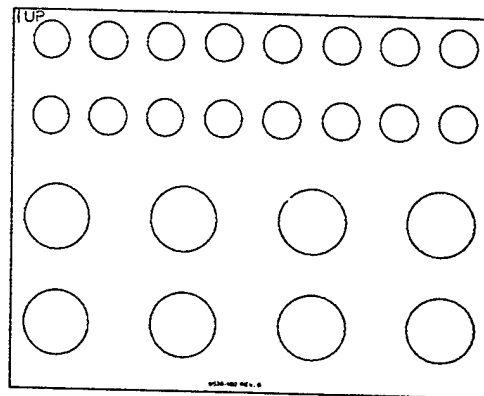

Polyurethane Foam Spacer

Figure 1: Initial microstrip antenna with asymmetrical beam pattern (from Seavey Report No. 9539-701, March 1996).

Summary of Test Results
 C-Band Buoy REDL
 Printed Circuit Antenna
 Seavey Engineering Associates Model No. 9539-800

March, 1996

Table 1-1

Frequency (GHz)	Gain (dBic)				Half Power Beamwidth		
	Peak	Elevation 40 deg. BW	Azimuth 24 deg. BW	Azimuth 12 deg. BW	Az.	El.	Dia. /45°
4.00	15.5	12.5	9.2	-	17°	40°	22°
4.10	16.0	12.7	9.7	-	17°	39°	22°
4.20	15.9	12.9	9.4	-	16°	40°	21°
Transmit							
6.25	17.6	13.3	-	14.6	12.0°	32.0°	14.5°
6.35	17.6	13.3	-	14.6	12.0°	31.5°	15.0°
6.45	17.8	13.6	-	14.4	11.5°	32.0°	15.0°

Table 1-2

Frequency (GHz)	Max. Sidelobe (dB)			VSWR	Axial Ratio (dB)	Isolation (dB)
	Az.	El.	Dia. /45°			
4.00	17°	40°	22°	1.33	4.5	>29
4.10	17°	39°	22°	1.33	2.5	>29
4.20	16°	40°	21°	1.26	3.0	>29
Transmit						
6.25	12.0°	32.0°	14.5°	1.22	4.5	>29
6.35	12.0°	31.5°	15.0°	1.12	4.5	>29
6.45	11.5°	32.0°	15.0°	1.12	3.5	>29

Table 1: Measured performance of the asymmetrical microstrip antenna shown in Figure 1. (From Seavey Report No. 9539-701, March 1996.)

From these data and the report included as Appendix 6.0, it is clear that this design met all of the RF requirements. The antenna is also a very small, lightweight design, easily mounted on a rotating fixture compatible with use on ocean buoys (under an appropriate radome). It is also inexpensive to produce.

2.2 Mechanical Steering System Design

The specification for beam pattern was a compromise between the required antenna gain (which is inversely proportional to beam width) and the expected pitch and roll motion of oceanographic buoys. Experience at WHOI using large discus buoys, typically 3m in diameter, suggests that pitch and roll angles beyond 15° occur infrequently even in rather heavy sea states [14], [15] and average tilts are normally in the $\pm 5^\circ$ range. Buoys equipped with wind vanes typically stay within $\pm 15^\circ$ of the wind direction under steady wind conditions. While these estimates are not definitive with regard to buoy motion in the presence of waves, they are based on standard 3m discus buoys in realistic sea states. For comparison, actively positioned antennas meant for ship applications are designed to tolerate pitch/roll motions of $\pm 10^\circ/\pm 30^\circ$ (InMarsat A) and $\pm 7^\circ/\pm 15^\circ$ (Direct TV) [10]. The WaveTalk antenna (used in the SKYSITE system) has a $\pm 22.5^\circ$ beam pattern in elevation, but is constrained to absolute angles between 15° and 60° above the horizon. It turns in azimuth at up to $70^\circ/\text{sec}$. It would be very instructive to install the Seavey microstrip antenna on a surface buoy such as the Bermuda Testbed Mooring [16] (a large hemispherical surface buoy equipped with a wind vane) to measure the net effect of buoy motion, pointing errors and transmission path fluctuations.

The mechanical steering arrangement is shown in Figure 3. It consists of a small stepper motor (escap Model EDM-483I) controlled by a single board controller (Onset Tattletale Model 8). A Precision Navigation, Inc. digital electronic compass (Model TCM2) is used to measure antenna orientation relative to magnetic north. A built in tilt sensor corrects the compass heading for buoy tilts. The compass is based on a triaxial magnetometer and a biaxial electrolytic inclinometer, and has no moving parts. It outputs compass heading, pitch and roll readings as often as 16 times per second. Compass accuracy is $\pm 1^\circ$ RMS at tilts of less than 20° . Tilt accuracy is $\pm 0.2^\circ$. Power drain is 100 mwatts. In the test setup operation, a known direction was input as the orientation reference (satellite location) and the antenna orientation was compared to this value twice a second by accessing the PNI compass output. If the two orientations differed, the stepper motor was commanded to return to the zero difference orientation. To avoid winding up the antenna leads, the controller reversed the direction of the stepper motor to avoid making more than $1 \frac{1}{2}$ turns around the antenna mounting shaft.

Specifications of the prototype mechanical steering system are;

Power drain: moving (24 watts); quiescent (12 watts)

Pointing accuracy: $\pm 1^\circ$

Response time: $\geq \frac{1}{2}$ sec

Maximum rotational speed: $\leq 558^\circ/\text{sec}$

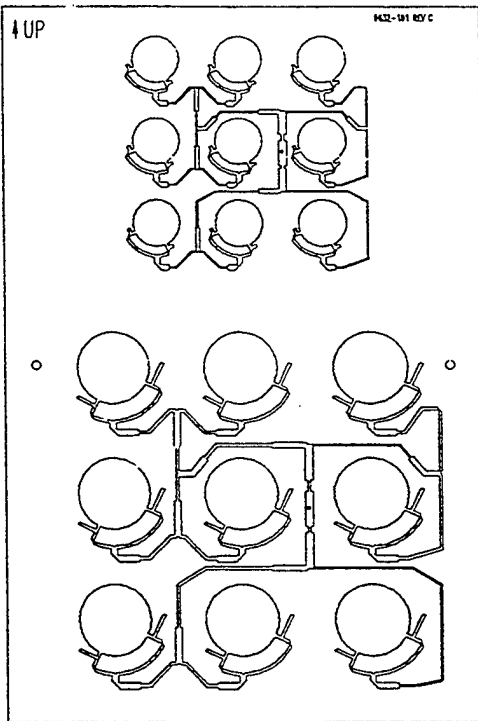

Rx & Tx Radiating Elements
and
Feed Networks

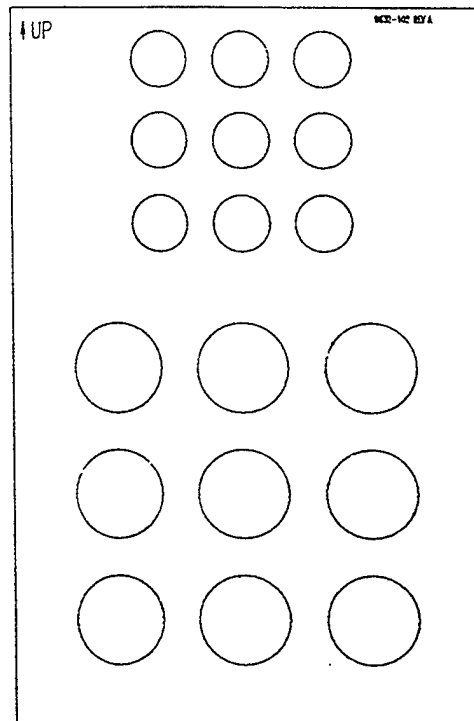

Rx & Tx Parasitic Arrays

Figure 2: Symmetric antenna design $\pm 15^\circ$ HPBW in azimuth and elevation (from Seavey Report No 9632-700, June 1996.)

Summary of Test Results
 30° HPBW
 C-Band Buoy REDL
 Printed Circuit Antenna
 Seavey Engineering Associates Model No. 9632-800

July, 1996

Table 1-1

Frequency (GHz)	Gain (dBic)	HPBW		Max. Side Lobe		VSWR	Axial Ratio (dB)	Isolation (dB)
		Az.	El.	Az.	El.			
Receive								
4.00	14.4	29°	30°	13.4	15.4	1.17:1	2.6	>37
4.10	14.6	28°	27°	12.5	15.3	1.19:1	3.3	>37
4.20	14.7	28°	28°	12.7	14.0	1.42:1	3.0	>37
Transmit								
6.25	14.2	31°	30°	14.7	15.0	1.12:1	2.6	>37
6.35	14.2	31°	29°	13.5	14.8	1.22:1	2.4	>37
6.45	14.3	30°	28°	12.4	14.3	1.34:1	2.7	>37

SPECIFICATIONS

Frequency:..... Rx: 4.0-4.2 GHz
 Tx: 6.25-6.45 GHz
 Polarization:.....Rx: RHCP
 Tx: LHCP
 Gain:.....14.0 dBic
 HPBW:.....30° Az & El
 VSWR:.....1.5:1
 Axial Ratio:.....4.0 dB
 Size:.....9.1" x 6.0"
 Weight:.....6 oz. (EST.)

Table 2: Measured performance of the symmetric antenna shown in Figure 2 (from Seavey Report No 9632-700, July 1996).

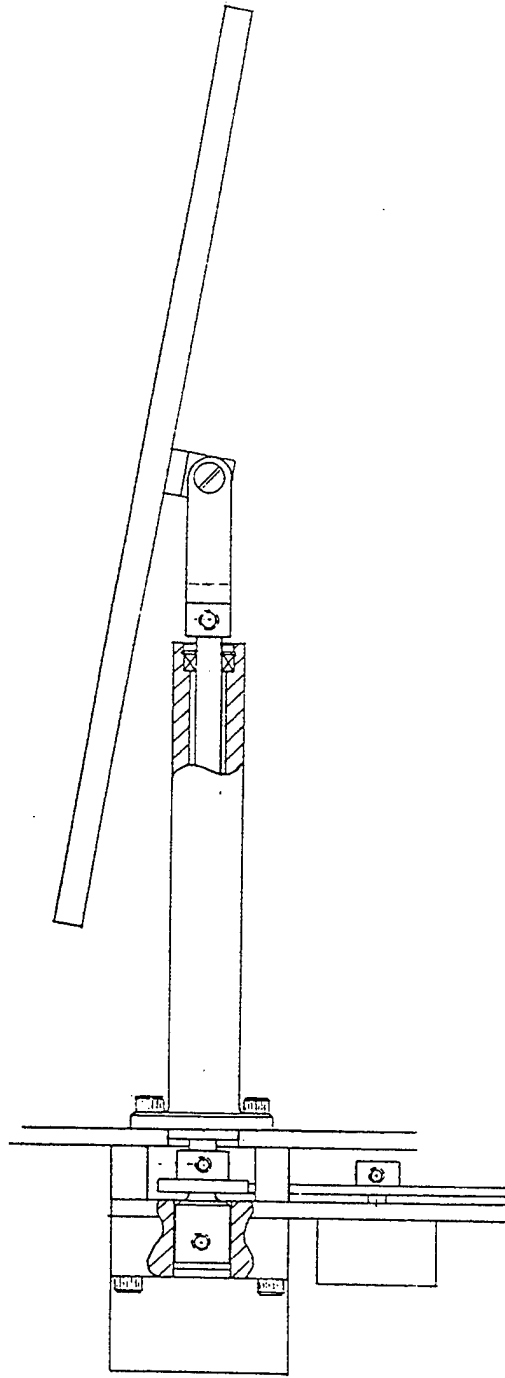

Figure 3: Mechanically steered antenna array

It should be noted that this prototype system was designed for use in the laboratory with off-the-shelf components and was not optimized for buoy use. In particular, the system using the stepper motor and controller uses more power and has a slower system response time than that of an analog system using a brush-type motor. The stepper motor system leads to excessive lag times which caused significant pointing errors at high rotational rates. The reasons for the lag are several. First is the computation time for the stepper motor to process a command, calculate the ramp up/down profile for the move, and then perform the actual move. Second, the number of computations and commands that the main controller has to perform in order to calculate the number of steps needed to maintain the correct heading is large. Third, the time needed to send and receive digital information from both the compass and the motor controller is several tenths of a second. In a system that uses a brush-type motor the overall response time could be reduced by eliminating most of these delays.

3.0 TEST RESULTS

3.1 Test Results with Rotating Table

Results of RF tests on the 18-element Seavey antenna are included in the Electrical Test Report in Appendix 6.0 which was prepared by Seavey Engineering Associates, Inc. The prototype antenna meets the specification in all significant measures. It provides 14 dB of gain at the center of the beam pattern and at least 11 dB of gain 15° on either side of the maximum in both elevation, azimuth, and in a 45° slice. It is small, lightweight and inexpensive to manufacture.

To test the mechanical steering technique proposed for ocean buoys, a test set up was constructed using the mechanical steering assembly shown in Figure 3 mounted on a rotating table (Figure 4). A second PNI compass was used to provide a fixed reference and a computer was set up to record table position (PNI compass 2) and antenna position (PNI compass 1) twice per second for table rotation rates of $2^\circ/\text{sec}$, $5^\circ/\text{sec}$, and $10^\circ/\text{sec}$. The control program was written so that any time the antenna position differed from the reference position by more than 1° , the stepper motor was actuated to reduce the difference. The motor speed was $60^\circ/\text{sec}$ and the rotating table had about 1° of deadband when changing direction. Figure 5A and 5B show the test setup in block diagram form.

Figures 6, 7 and 8 show the system response to steady rotation at $2^\circ/\text{sec}$, $5^\circ/\text{sec}$ and $10^\circ/\text{sec}$. The upper plot is the antenna orientation and the lower plot is the table orientation. The straight line on the upper plot is the fixed reference position (satellite heading). Figure 9 shows the antenna orientation data collected at all three speeds on the same scale. These plots illustrate two features of the system. The system noise and the pointing accuracy are proportional to the speed of rotation. The overall performance is controlled by the system lag time which, in this case, is about $\frac{1}{2}$ sec which explains why the errors are about 1° , $2\frac{1}{2}^\circ$, and 5° at $2^\circ/\text{sec}$, $5^\circ/\text{sec}$, and $10^\circ/\text{sec}$, respectively. This lag time is primarily a function of the controller spending time collecting information from several sensors over RS232 lines and then sending digital commands

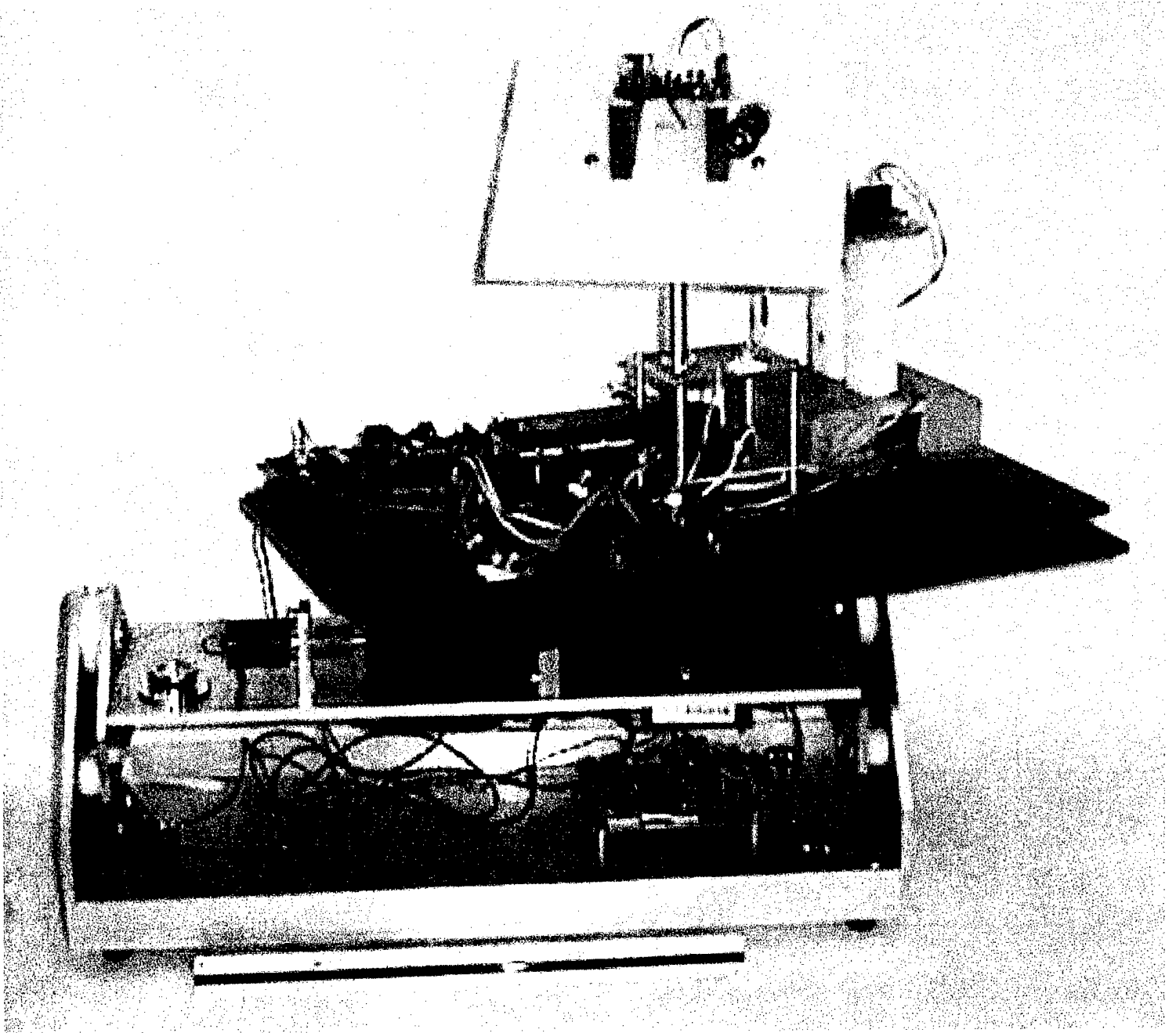

Figure 4: Test configuration showing the rotating table, measurement electronics, and antenna mount (white circuit board with small laser pencil mounted on it).

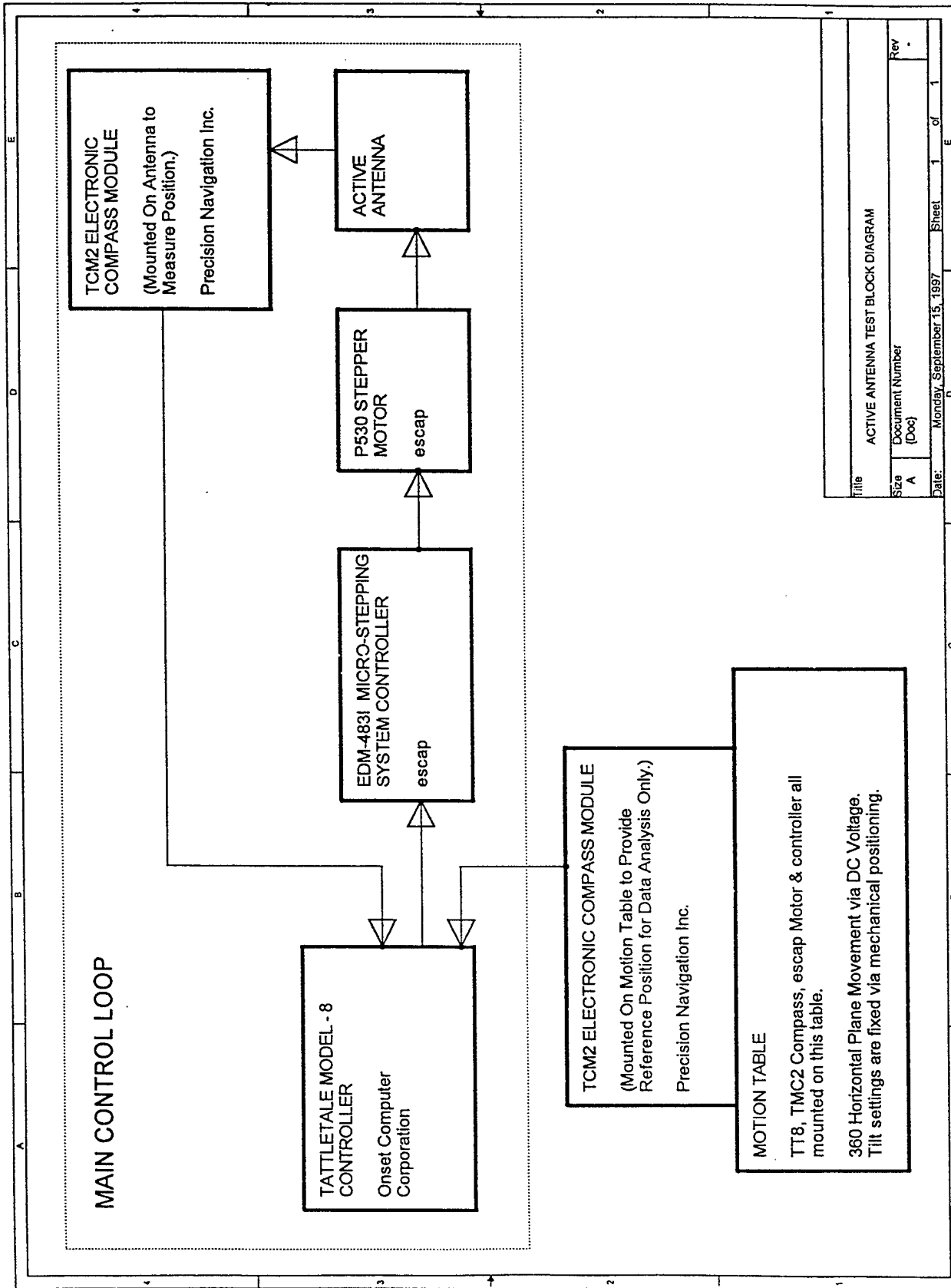
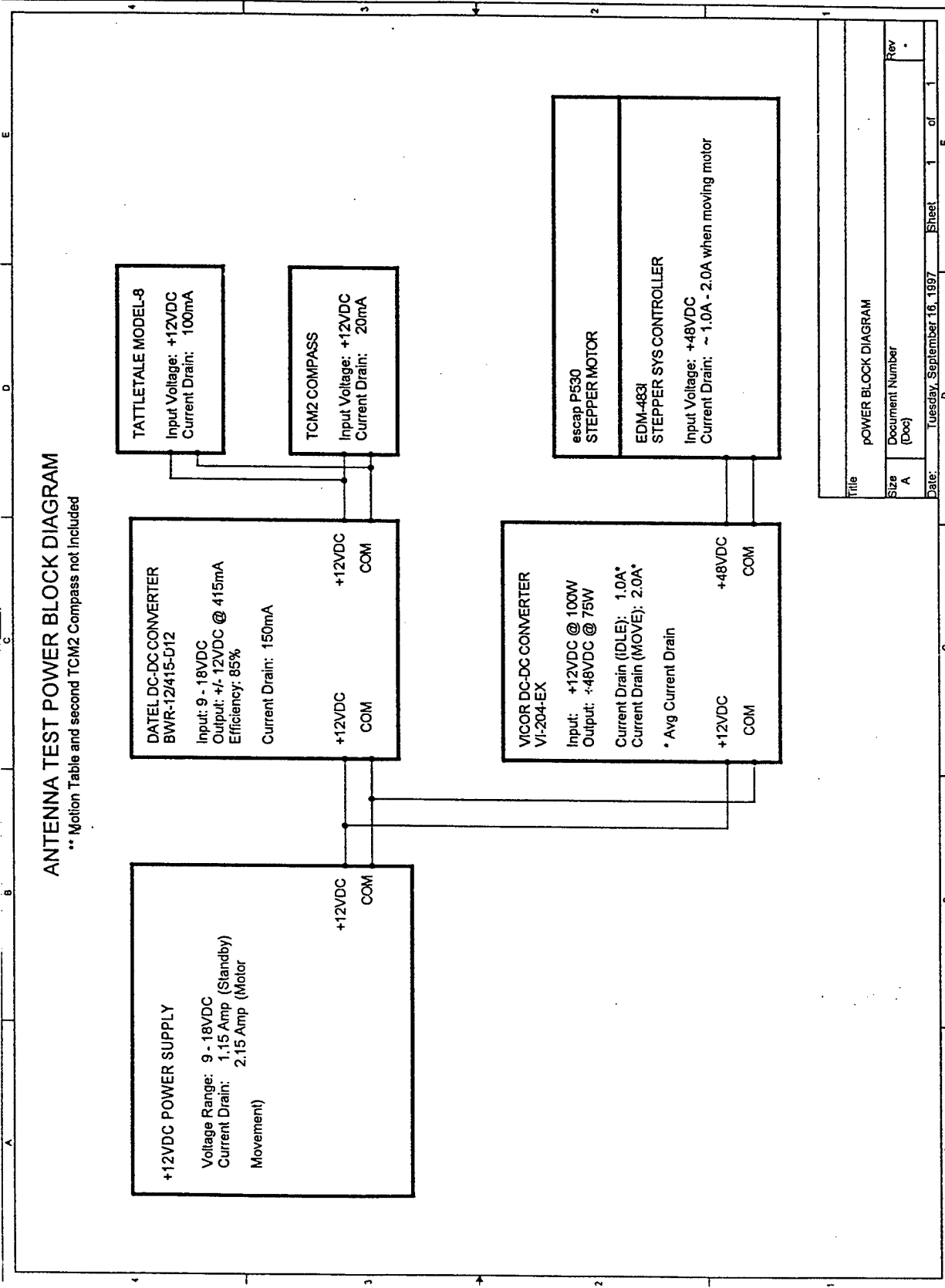

Figure 5A: Antenna test setup block diagram



ANTENNA TEST POWER BLOCK DIAGRAM

** Motion Table and second TCM2 Compass not included

TATTLETALE MODEL-8
 Input Voltage: +12VDC
 Current Drain: 100mA

TCM2 COMPASS
 Input Voltage: +12VDC
 Current Drain: 20mA

DATEL DC-DC CONVERTER
 BWR-12/415-D12
 Input: 9 - 18VDC
 Output: +/- 12VDC @ 415mA
 Efficiency: 85%
 Current Drain: 150mA

VICOR DC-DC CONVERTER
 VI-204-EX
 Input: +12VDC @ 100W
 Output: +48VDC @ 75W
 Current Drain (IDLE): 1.0A*
 Current Drain (MOVE): 2.0A*
 * Avg Current Drain

escap P530 STEPPER MOTOR
EDM-483 STEPPER SYS CONTROLLER
 Input Voltage: +48VDC
 Current Drain: ~ 1.0A - 2.0A when moving motor

+12VDC POWER SUPPLY
 Voltage Range: 9 - 18VDC
 Current Drain: 1.15 Amp (Standby)
 2.15 Amp (Motor Movement)

Title		POWER BLOCK DIAGRAM
Size	Document Number	Rev
A		.
Date:	Tuesday, September 16, 1997	Sheet 1 of 1

Figure 5B: Antenna test setup power block diagram

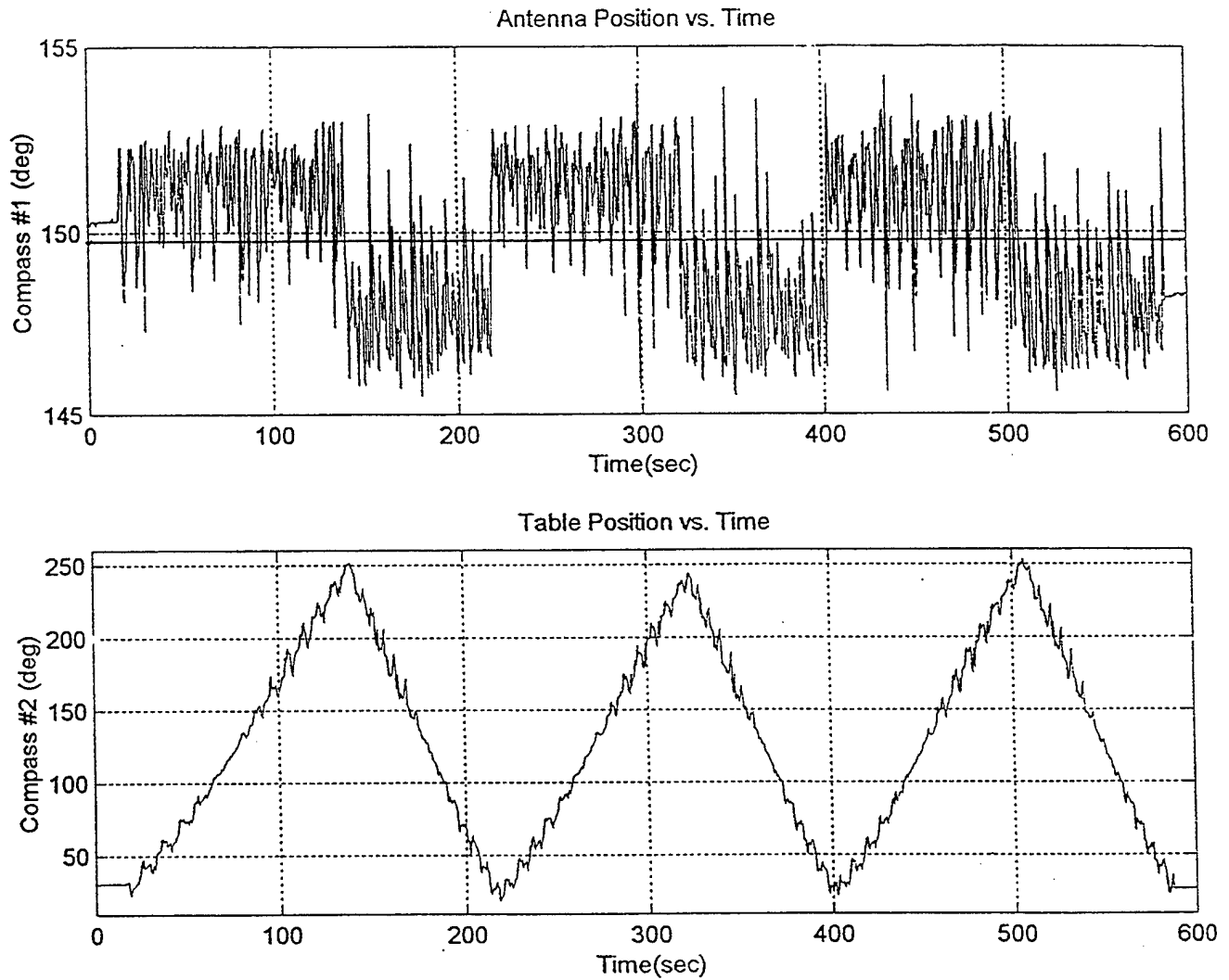

Figure 6: Top plot shows antenna orientation versus time for the table orientations shown in the lower plot. The fixed reference direction is the straight line at 149.7°. Table rotation speed is 2°/sec.

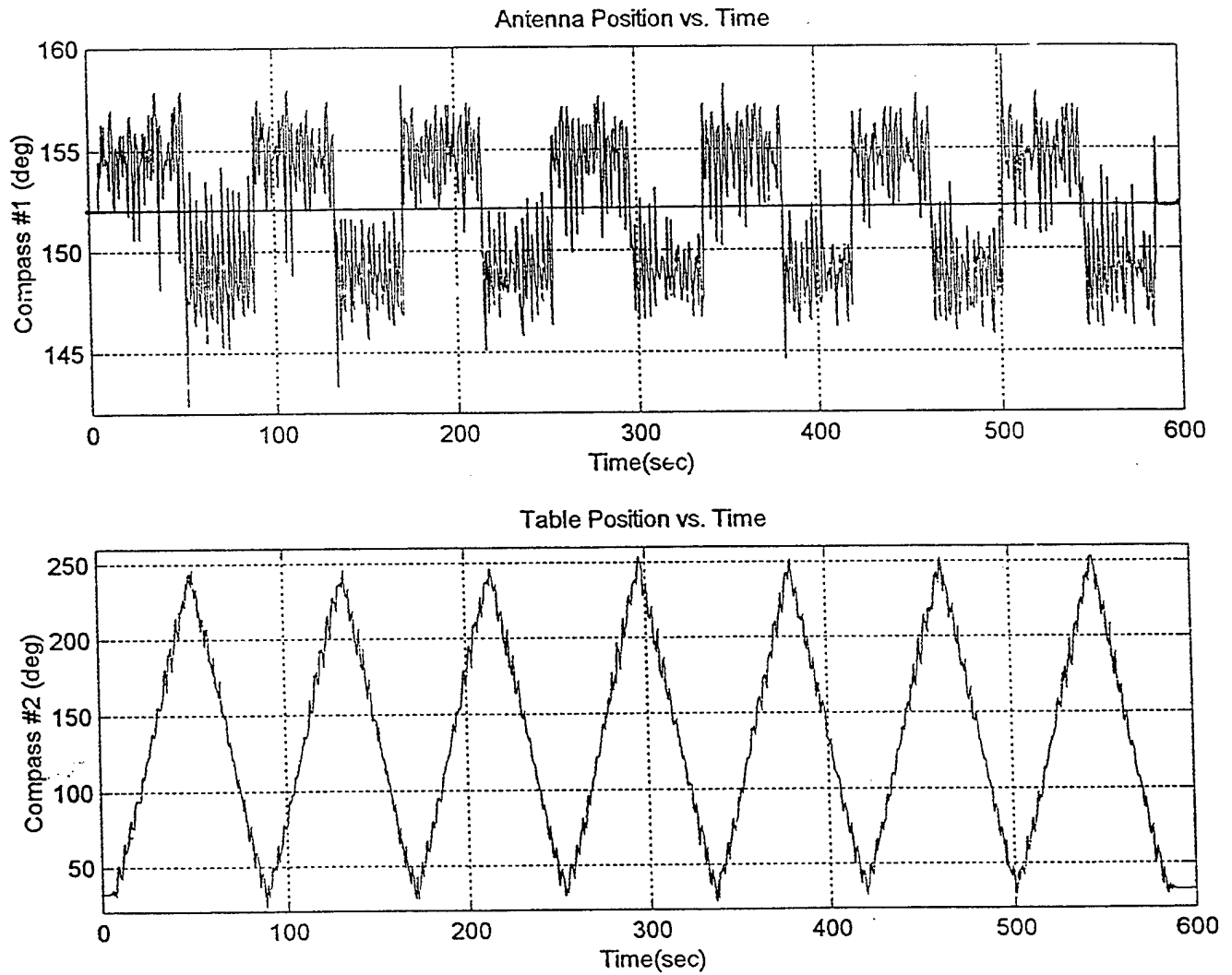

Figure 7: Top plot shows antenna orientation versus time for the table orientations shown in the lower plot. The fixed reference direction is the straight line at 152° . Table rotation speed is $5^\circ/\text{sec}$.

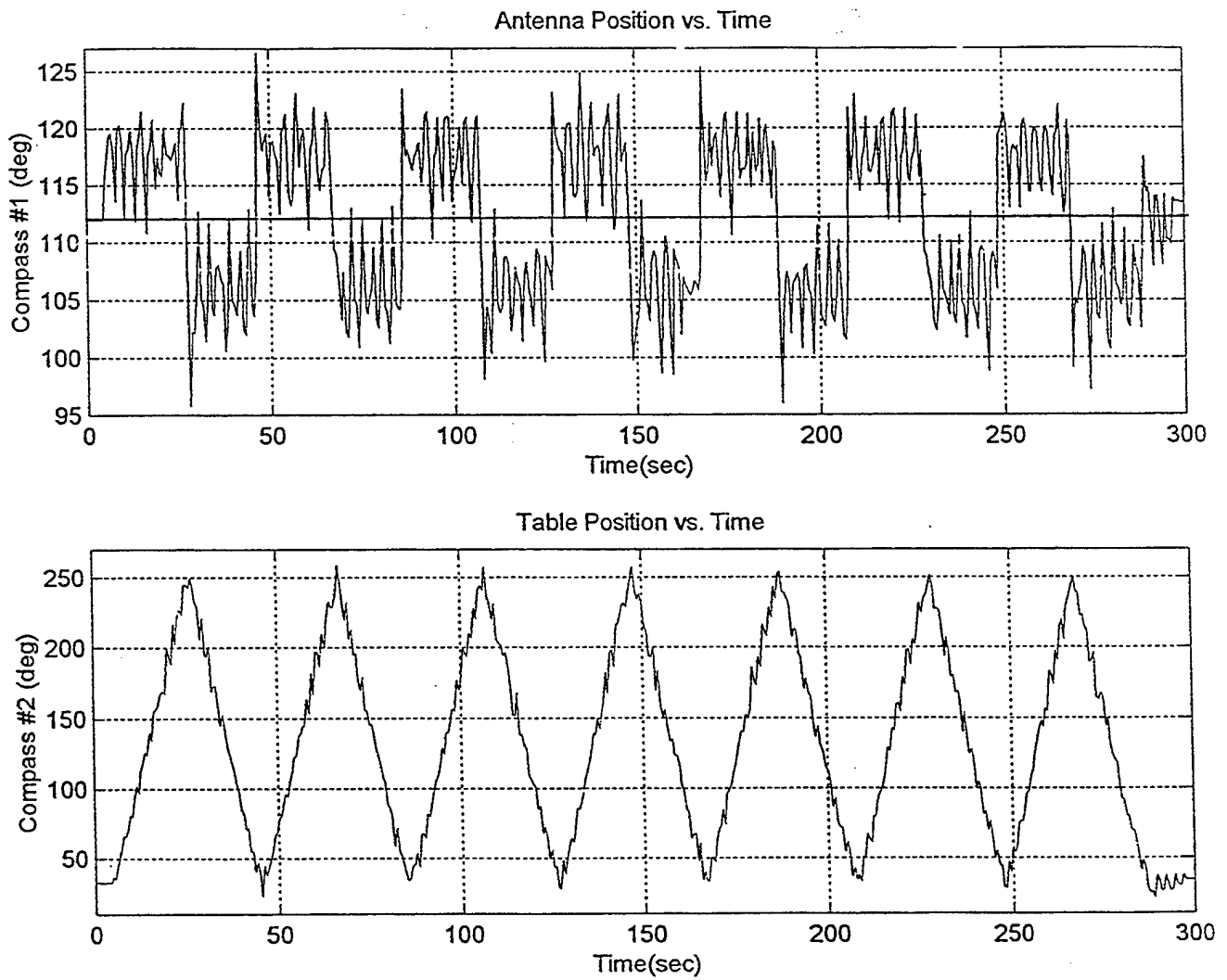

Figure 8: Top plot shows antenna orientation versus time for the table orientations shown in the lower plot. The fixed reference direction is the straight line at 112° . Table rotation speed is $10^\circ/\text{sec}$.

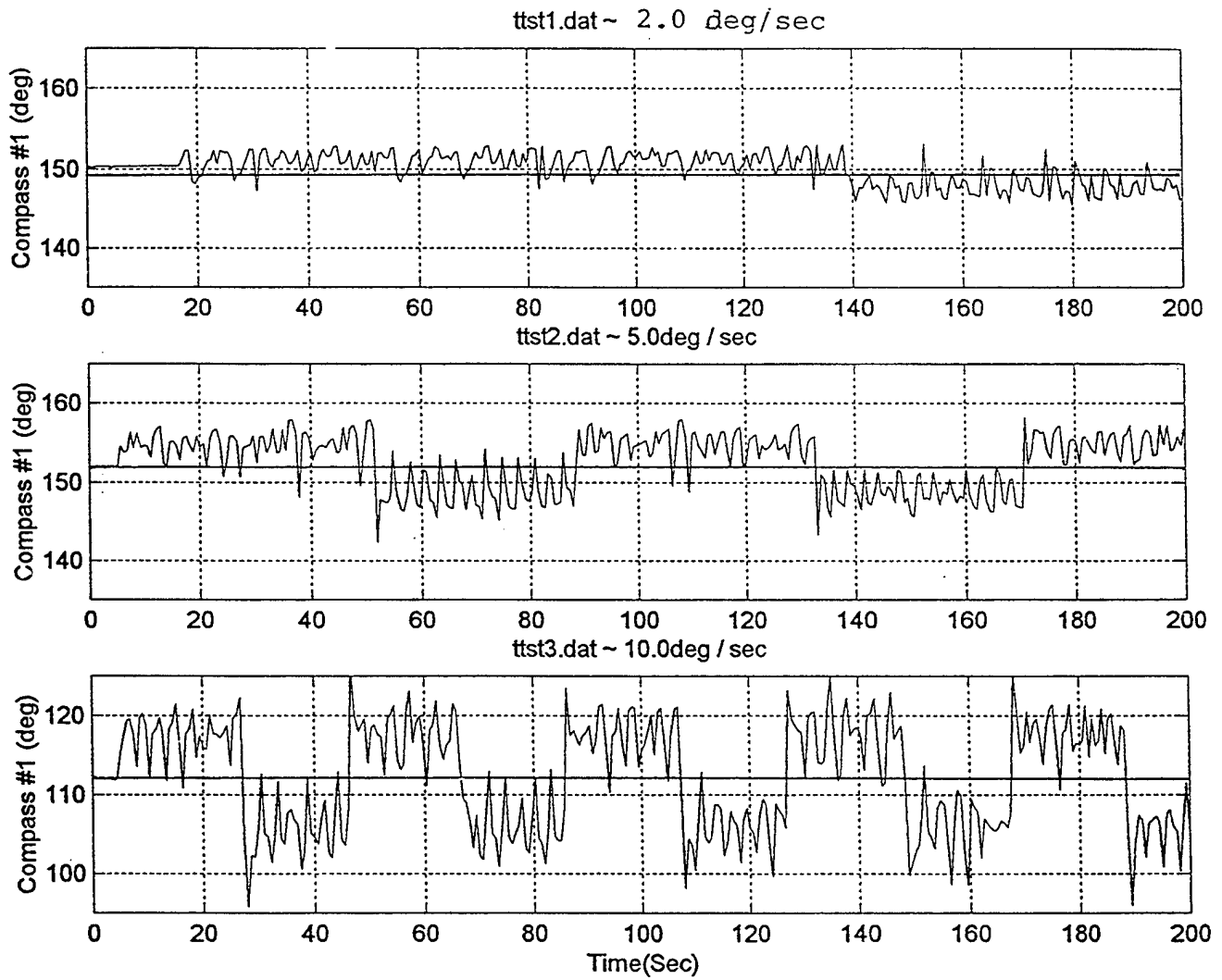

Figure 9: Plots showing antenna orientation versus time for table rotation speeds of 2°/sec (top), 5°/sec (middle), and 10°/sec (bottom)

to the stepper motor controller. It could be considerably shortened by redesigning the system as discussed above.

3.2 Test Results with Tilted Rotating Table

Figure 10 shows the performance of the system with fixed tilts of 0, 10 and 20° to the rotating table for a rotation speed of 3°/sec. Figure 11 is the analogous plot for a table rotation speed of 10°/sec. The result of these fixed tilts is to cause a changing tilt in the antenna as it rotates in the opposite direction from the table. The purpose of these plots is to get an idea of how the compass is affected by fluctuating tilts such as a buoy would see. While these angles are realistic for an ocean buoy, additional accelerations due to heave and horizontal translations may also play a significant role in system accuracy in a deployed system. Figures 10 and 11 illustrate that the additional errors added by the fixed tilt experiment are small compared to the system lag. However, it may be necessary to incorporate a rate gyro into the sensor system to achieve the accuracy requirement on ocean buoys in dynamic environments.

4.0 DISCUSSION

The feasibility of using a mechanically steered directional antenna on an ocean buoy has been investigated by developing an antenna to provide the gain and beam pattern needed to reach a geostationary satellite in the presence of realistic values of buoy pitch and roll. A prototype rotating antenna mount was built to look at the feasibility of maintaining orientation in the presence of realistic buoy yaw motions. Large surface buoys with wind vanes are relatively stable in yaw at normal wind speeds, usually maintaining direction coincident with the wind to within about 15°. Wind direction over the ocean is relatively more constant than over land. Buoy yaw rates are not well known, but if it is assumed that they search over $\pm 15^\circ$ over one wave period, this suggests typical yaw rates of 10°/sec or less for large buoys with wind vanes.

Based on these preliminary estimates of buoy motion, the mechanically steered antenna will meet the requirement to keep the satellite within its ½ power beamwidth a high percentage of the time. This assumes that the rotating system can be redesigned with a lag time ≤ 0.2 sec, which should be feasible without any great design leaps. Since we have not been able to model the system response under a wide range of measured buoy motions, this is a preliminary conclusion which needs to be documented with a period of at-sea testing. At-sea tests, however, require operational RF hardware and a satellite to transmit to, so we are not able to proceed to the next step at this time.

Considerable research in the area of mechanically steered and electrically steered antenna arrays has been conducted over the last decade. The objectives of this work are to develop medium gain (~15dB) antennas that allow mobile transceivers to reach geostationary or orbiting satellites using less power than would be required using a low gain omni-directional antenna. Applications include cellular telephone sets, truck monitoring, rail car monitoring, ship communications, etc. A number of prototype systems have been designed and tested, particularly in L-band (1-2 GHz) [17].

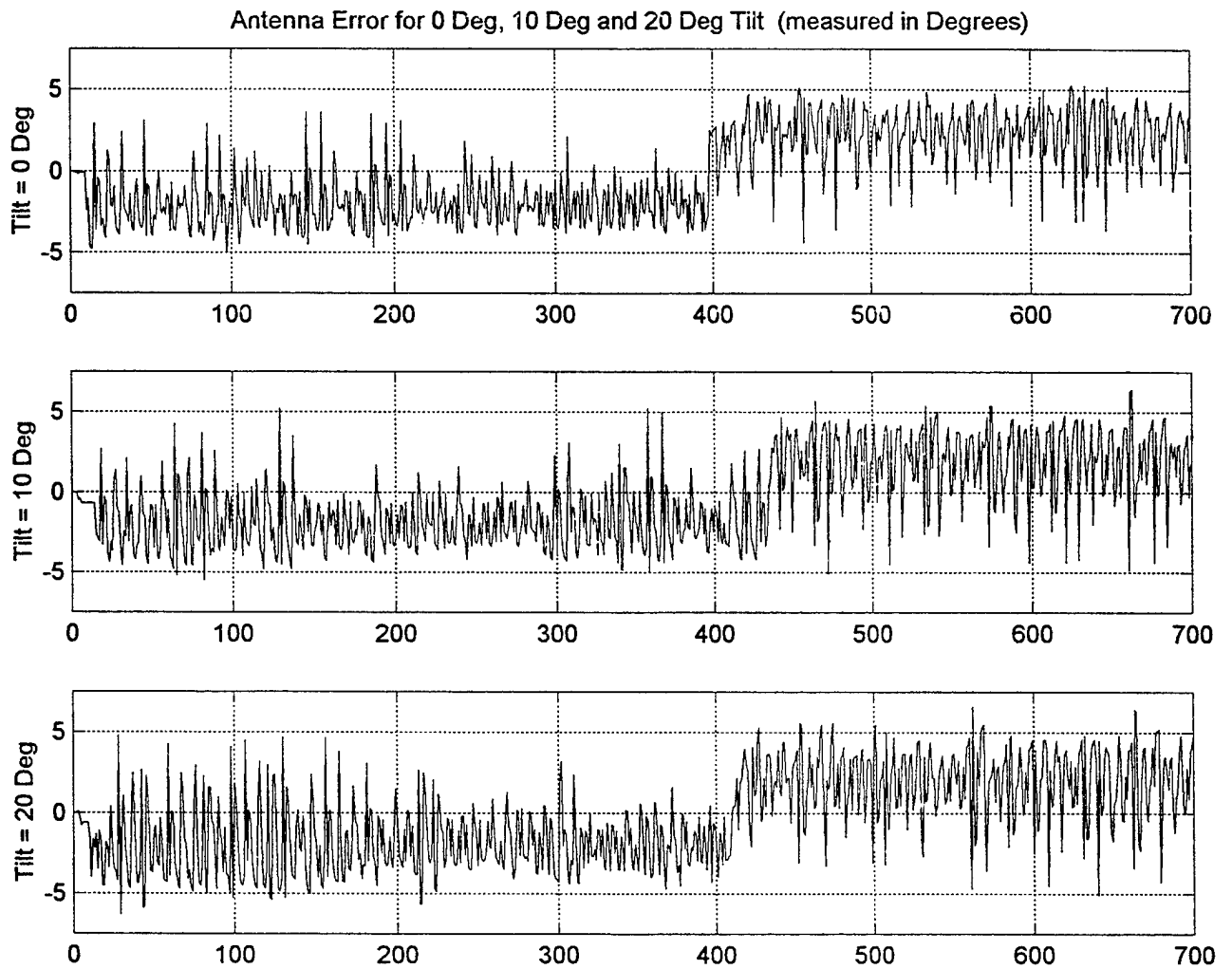

Figure 10: Antenna pointing error for 0° tilt (top), 10° tilt (middle), 20° tilt (bottom), and table rotation speed of 3°/sec.

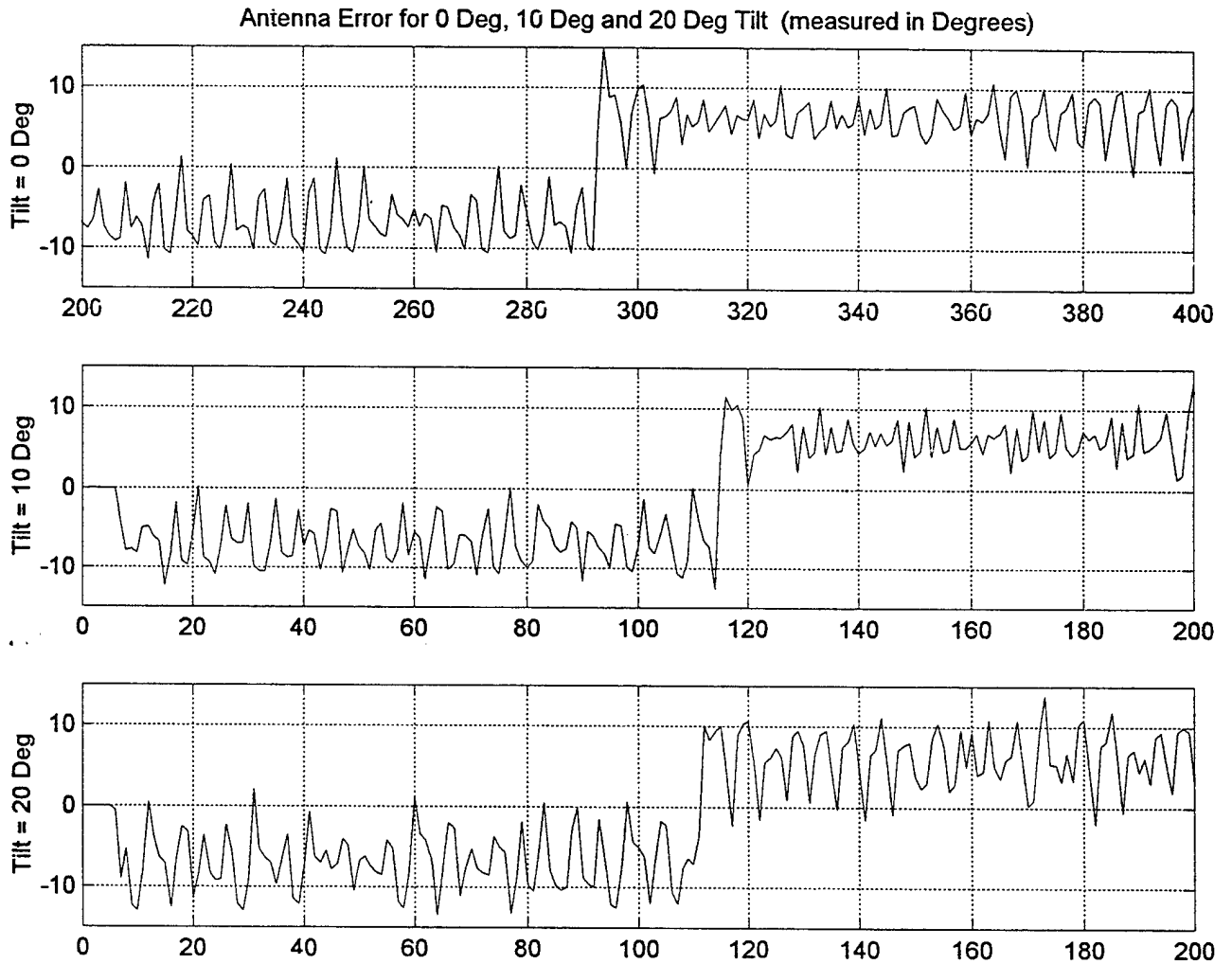

Figure 11: Antenna pointing error for 0° tilt (top), 10° tilt (middle), 20° tilt (bottom), and table rotation speed of 10°/sec.

The mechanically-steered systems have typically used a stepper motor to rotate the antenna in azimuth, and a fairly broad beam pattern in elevation. They use either closed-loop tracking, i.e., using a signal from the satellite to search and hold the satellite direction, or open-loop tracking which uses only sensors such as compasses and rate sensors to orient the antenna. Typically a rate sensor is used in either case for high frequency corrections to the antenna orientation.

Electrically steered arrays use either phased array antennas that are actively steered by beamforming or switched arrays that have fixed orientations and are switched on or off depending on the orientation of the antenna fixture. A truncated pyramid with multi-element arrays on each of 4 faces is an example of the second type. Electrically steered arrays offer the advantage of no moving parts, small size, and potentially very low cost. Their disadvantage is much higher development cost and high computational requirements. Electrically steered antennas will ultimately be the system of choice for mobile communications systems, but significant technological problems must still be solved before they are practical in most applications.

While the project has been underway, several commercial developments have occurred which may have a bearing on our results. Westinghouse has introduced its SKYSITE service, which provides telephone service via geostationary satellite (MSAT) with coverage over the U.S., Canada, Central American and coastal regions of the Pacific and the Atlantic, and the entire Gulf and Caribbean Seas. Most interestingly, their service is designed for fixed site, land mobile, maritime and aircraft users and they offer both an omni-directional antenna and a mechanically steered directional antenna. To be accurate, the omni-directional antenna is a high gain antenna with 360° azimuthal coverage, but a narrow beam in elevation. The mechanically steered directional antenna operates on a conceptual design similar to the WHOI design described in this report. It tracks the satellite in azimuth using a received signal and a rate gyro to maintain orientation (closed-loop tracking) and has a broad elevation beam designed to cover between 15 and 60° above the horizon. This beamwidth is expected to maintain satellite tracking in the presence of vessel pitch and roll. One difference in the Westinghouse design is that the antenna operates at the same angle in all latitudes while the WHOI system is tilted to center its beam for a specific latitude. This allows the WHOI system to accommodate wave motions with a narrower antenna beam angle and thus higher antenna gain.

The technical issues aside, the availability of a low cost, operational mechanically steered directional antenna for use with geostationary satellites means our development program may have been overtaken by the commercial sector. While the Westinghouse system provides less than global marine coverage, it does provide significant coverage and its advertised rates of \$1.45/minute at 2400 bit/s suggest a cost/byte at least two orders of magnitude less expensive than Service Argos. Power requirements are high at 75 watts receive, 85 watts transmit, but not totally unmanageable on a large ocean buoy.

A second commercially available mechanically steered antenna for receiving satellite broadcast signals is now offered by KVH for Direct TV applications on small boats. It uses

KVH's digital gyro compass system to control pointing orientation of a small dish antenna. The pointing system uses four small motors to tilt the dish about a center point without requiring any rotation. The system is somewhat power intensive, but has high dynamic response and is compact considering the size of the dish.

Our conclusion based on these commercial developments is that we need to better understand their capabilities and limitations before pursuing our prototype approach further. For instance, it may make more sense to try and reduce the power consumed by the WaveTalk antenna (Westinghouse) than to complete the design of our system and go through the time consuming testing and demonstration process needed to be sure that our approach offers major advantages. Tests of the Viasat communication system using the Seavey antenna on a vessel (to manually handle the pointing requirement) would be a useful step toward a more globally available system. These comments are relevant to the antenna pointing issue only, not to the Viasat telemetry technique.

5.0 REFERENCES

- [1] Briscoe, M.G. and D. E. Frye, "Motivations and methods for ocean data telemetry," *Marine Technology Society Journal*, 21 (2), pp 42-57 , 1987.
- [2] Service Argos, Inc., User Manual, Version 1, November 1988.
- [3] MacCallum, D. H. and M. J. Nestlebusch, "The geostationary operational environmental satellite data collection system," NOAA Tech. Mem. NESDIS 2: 55 pp, 1983.
- [4] Hanlon, J., "Emerging LEOs telemetry options for scientific data buoys - a marine instrument manufacturer's perspective," *Oceans '97*, Halifax, N.S. 1997.
- [5] Wu, W.W., E. F. Miller, W.L. Pritchard, and R.L. Pickholz, "Mobile satellite communications," *Proc. of the IEEE*, Vol. 82, No. 9, pp. 1431-1448, September 1994.
- [6] Brown, J., Seimac, Ltd., private communication.
- [7] Lopez, O.K., "Satellite voice/data advancements," *Sea Technology*, May 1997.
- [8] VonderHeydt, K., Woods Hole Oceanographic Institution, private communication.
- [9] Shantzle, T., JAS Research, private communication.
- [10] Godara, L.C., "Applications of antenna arrays to mobile communications, part I: performance improvement, feasibility, and system considerations," *Proc. of the IEEE*, Vol. 85, No. 7, pp. 1031-1060, July 1987.

- [11] Ohmori, S., "Vehicle antennas for mobile satellite communications," IEICE Transactions, Vol. E74, No. 10, pp. 3210-3221, 1991.
- [12] Gamache, K., "Remote environmental datalink, draft phase II final report," Viasat, Inc., December 1996.
- [13] Anon, "Radiation pattern measurements 30° HPBW C-band buoy REDL printed circuit antenna," Electrical Test Report No. 9632-700, Seavey Engineering Associates, Inc., July 1996.
- [14] Gnanadesikan, A., Princeton University, private communication.
- [15] Grosenbaugh, M., Woods Hole Oceanographic Institution, private communication.
- [16] Dickey, T., "Bermuda testbed mooring program," Bulletin American Meteorological Society, 76, 584, 1995.
- [17] Aurinsalo, J., I. Huhtinen, A. Hujanen, A. Jongejans, I. Marttila, R. Mutanen, I. Pitkanen, P. Rinous, T. Salminen, S. Tallqvist, M.N. Travers, "Steerable L-band antennas for land mobile terminals," Proc. IEEE 44th Vehicular Technology Conf., Stockholm, Sweden, 1994, pp. 600-604.

6.0 APPENDIX

Electrical Test Report - 30° HPBW C-Band Buoy REDL Printed Circuit Antenna,
Seavey Engineering Associates.

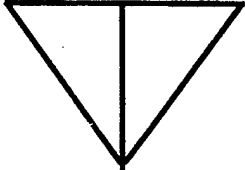

ELECTRICAL TEST REPORT

RADIATION PATTERN MEASUREMENTS

**30° HPBW
C-BAND BUOY REDL
PRINTED CIRCUIT ANTENNA**

PREPARED FOR:

**WOODS HOLE OCEANOGRAPHIC INSTITUTION
86 WATER STREET/MAIL STOP 18
WOODS HOLE, MA 02543**

Authorization: P.O. #E100506

Report No. 9632-700

July, 1996

SEAVEY ENGINEERING ASSOCIATES, INC.

135 King Street, Cohasset, MA 02025

(617) 383-9722 • FAX (617) 383-2089



TABLE OF CONTENTS

List of Illustrations	2
Introduction	3
Test Article	3
Appendix A Acceptance Test Procedure	
Appendix B Outline Drawing No. 9632-800	

LIST OF ILLUSTRATIONS

TABLE	TITLE
1-1	Summary of Electrical Testing

FIGURE	TITLE
1a.	Antenna Layers
1-1	4.00 GHz, Azimuth Plane RHCP Radiation Pattern
1-2	4.00 GHz, Elevation Plane RHCP Radiation Pattern
1-3	4.10 GHz, Azimuth Plane RHCP Radiation Pattern
1-4	4.10 GHz, Elevation Plane RHCP Radiation Pattern
1-5	4.20 GHz, Azimuth Plane RHCP Radiation Pattern
1-6	4.20 GHz, Elevation Plane RHCP Radiation Pattern
1-7	6.25 GHz, Azimuth Plane LHCP Radiation Pattern
1-8	6.25 GHz, Elevation Plane LHCP Radiation Pattern
1-9	6.35 GHz, Azimuth Plane LHCP Radiation Pattern
1-10	6.35 GHz, Elevation Plane LHCP Radiation Pattern
1-11	6.45 GHz, Azimuth Plane LHCP Radiation Pattern
1-12	6.45 GHz, Elevation Plane LHCP Radiation Pattern
1-13	Receive Axial Ratio @ Boresight
1-14	Transmit Axial Ratio @ Boresight
1-15	Receive Swept Return Loss
1-16	Transmit Swept Return Loss
1-17-19	Receive Expanded Swept Return Loss
1-20-22	Transmit Expanded Swept Return Loss

30° HPBW C-BAND BUOY REDL PRINTED CIRCUIT ANTENNA

Introduction

This report summarizes the electrical performance of Seavey Engineering Associates (S.E.A.) Model No. 9632-800, 30° HPBW C-band buoy REDL printed circuit antenna. It includes a description of the Antenna Under Test (AUT), a list of antenna specifications and a table summarizing the antenna's electrical performance. Also included is outline drawing No. 9632-800 and Acceptance Test Procedure (DOC #ATP-9632-800) located in appendices A and B respectively.

Test Article

The antenna tested is of printed circuit design using techniques obtained from literature [Hori and Nakajima], [James and Hall]. The antenna consists of one receive and one transmit microstrip array. The receive array operates in the frequency range of 4.0 - 4.2 GHz and exhibits right hand circular polarization. The transmit antenna operates in the frequency range of 6.25 - 6.45 GHz and exhibits left hand circular polarization. Each array consists of nine microstrip radiating elements and is fed with equal phase and amplitude distribution. A parasitic circuit is positioned above the radiating elements for increased bandwidth and electrical performance.

The feed circuitry and radiating elements are printed on a 6.00" wide x 9.125" tall x .063" thick Teflon glass substrate ($Dk = 2.50$). The parasitic arrays are printed on a sheet of 3 mil FR4 that is spaced above the radiating elements by a sheet of .125" thick polyurethane foam (See FIG. 1a for more details). Two Type-N female connectors have been provided for Rx and Tx access and is shown on outline drawing No. 9632-800 located in appendix A.

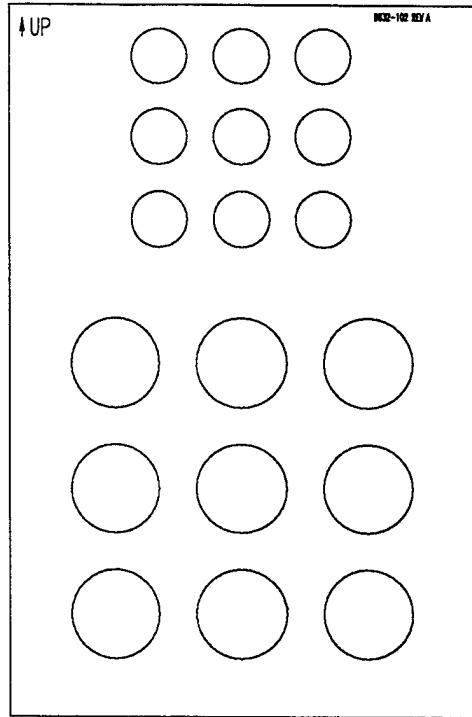
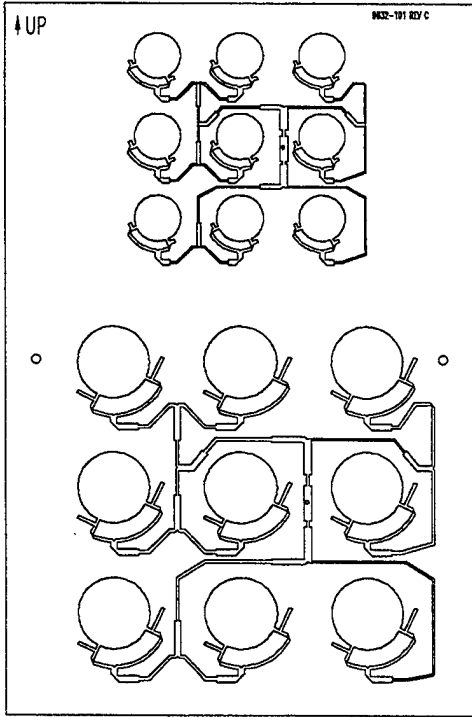

Rx & Tx Radiating Elements
and
Feed Networks

Rx & Tx Parasitic Arrays

FIGURE 1a. Antenna Layers

**Summary of Test Results
 30° HPBW
 C-Band Buoy REDL
 Printed Circuit Antenna
 Seavey Engineering Associates Model No. 9632-800**

July, 1996

Table 1-1

Frequency (GHz)	Gain (dBic)	HPBW		Max. Side Lobe		VSWR	Axial Ratio (dB)	Isolation (dB)
		Az.	El.	Az.	El.			
Receive								
4.00	14.4	29°	30°	13.4	15.4	1.17:1	2.6	>37
4.10	14.6	28°	27°	12.5	15.3	1.19:1	3.3	>37
4.20	14.7	28°	28°	12.7	14.0	1.42:1	3.0	>37
Transmit								
6.25	14.2	31°	30°	14.7	15.0	1.12:1	2.6	>37
6.35	14.2	31°	29°	13.5	14.8	1.22:1	2.4	>37
6.45	14.3	30°	28°	12.4	14.3	1.34:1	2.7	>37

SPECIFICATIONS

Frequency:..... Rx: 4.0-4.2 GHz
 Tx: 6.25-6.45 GHz
 Polarization:.....Rx: RHCP
 Tx: LHCP
 Gain:.....14.0 dBic
 HPBW:.....30° Az & El
 VSWR:.....1.5:1
 Axial Ratio:.....4.0 dB
 Size:.....9.1" x 6.0"
 Weight:.....6 oz. (EST.)

PATTERN NO. 1-1 DATE 7/1/96
PROJECT 9632-700
ENGRS.

REMARKS H.O.G.H.L.
Azimuth Cut
RHCP
Receive

SEAVEY ENGINEERING ASSOCIATES, INC.
135 KING STREET, P.O. BOX 44
COHASSET, MA 02025

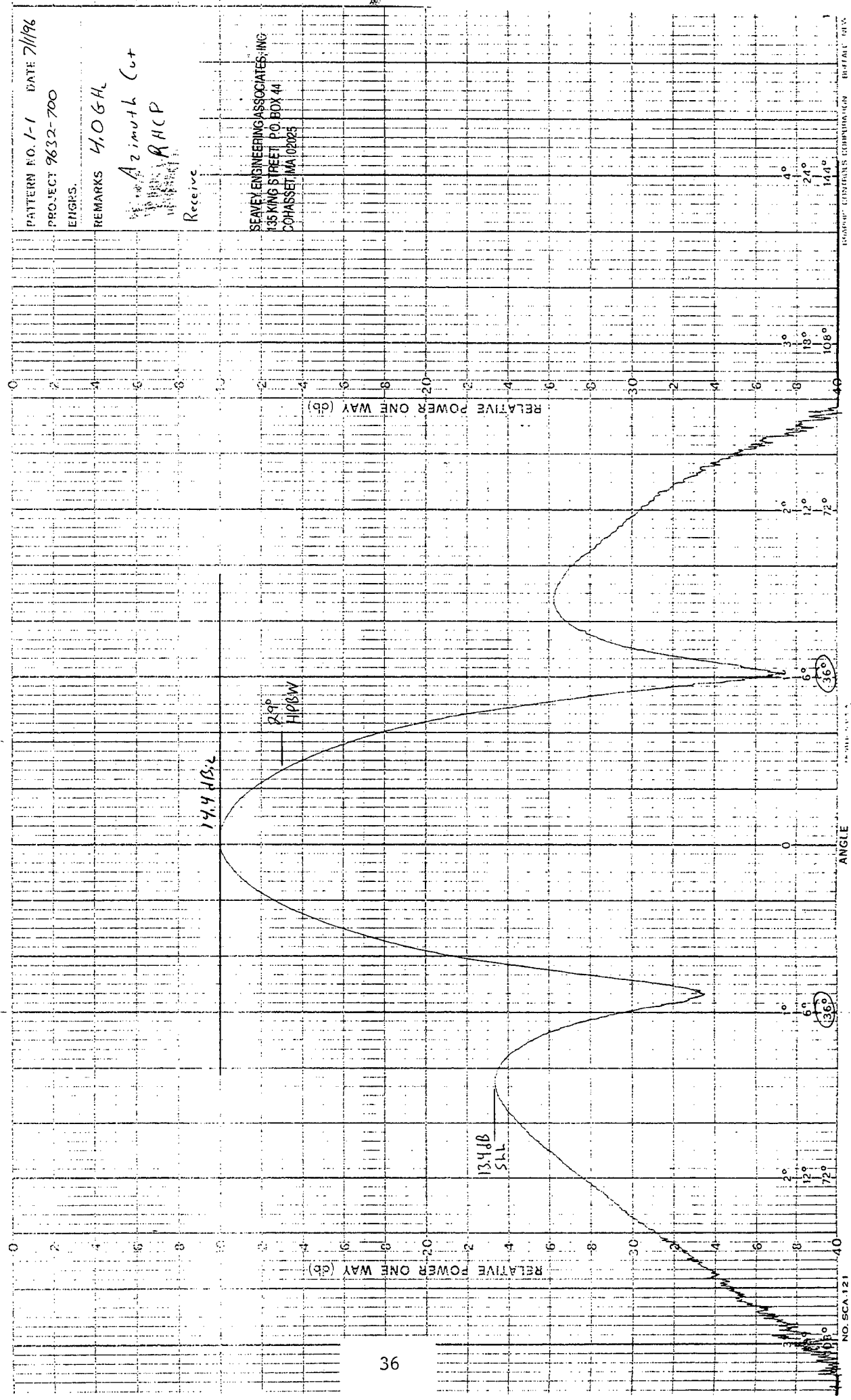

PATTERN NO. 1-2 DATE 7/1/66
 PROJECT 7632-700
 ENGRS.

REMARKS 4,064 Hz
 Elevation
 RHCP

Receive

SEAVEY ENGINEERING ASSOCIATES, INC
 135 KING STREET, P.O. BOX 444
 COHASSET, MA 02025

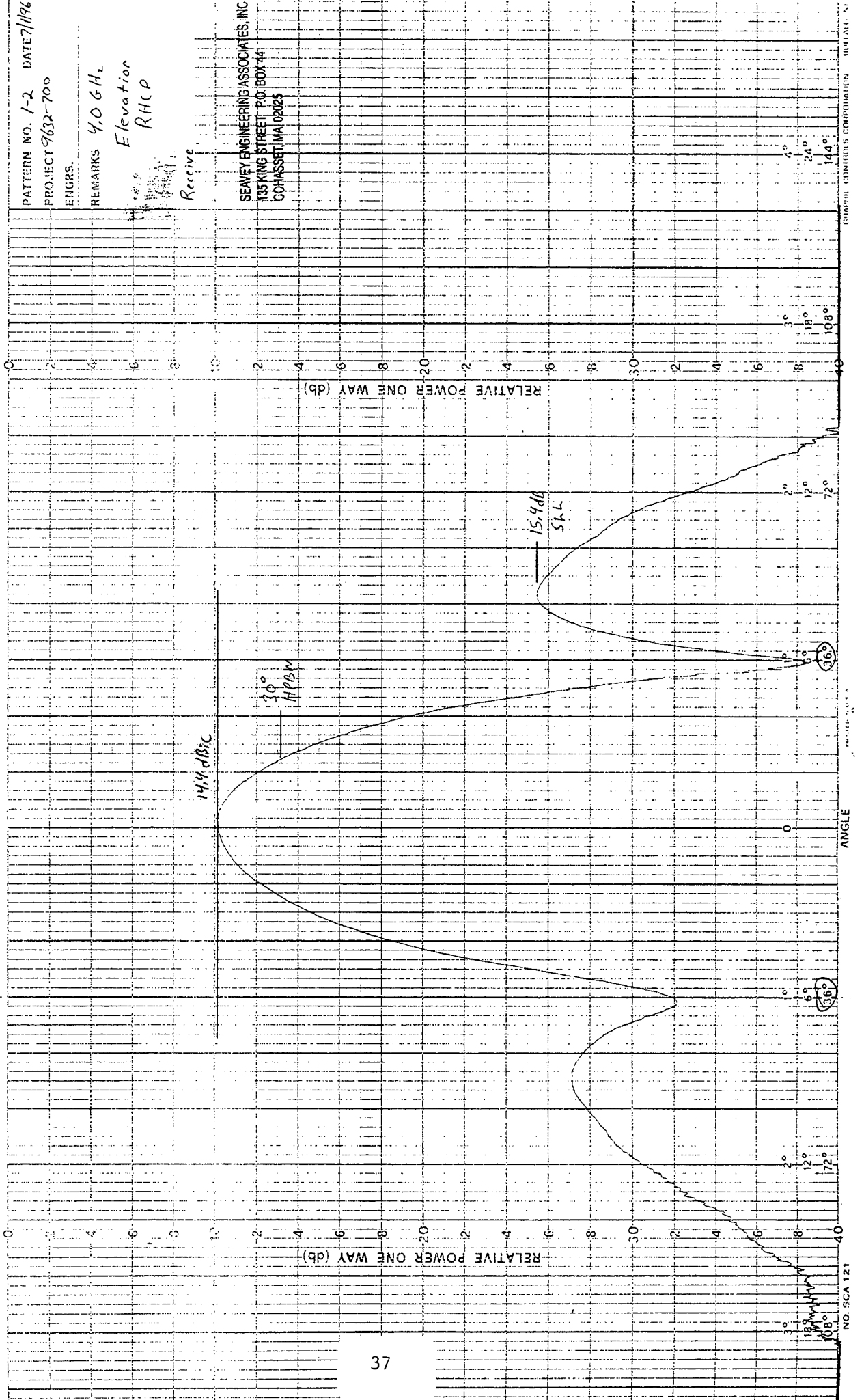

PATTERN NO. 1-3 DATE 7/1/96
PROJECT 9632-700
ENGRS.

REMARKS 4.1 GHz

Asimuth Cut
RHCP

Receive

SEAVEY ENGINEERING ASSOCIATES, INC.
135 KING STREET, P.O. BOX 44
COHASSETT, MA 01925

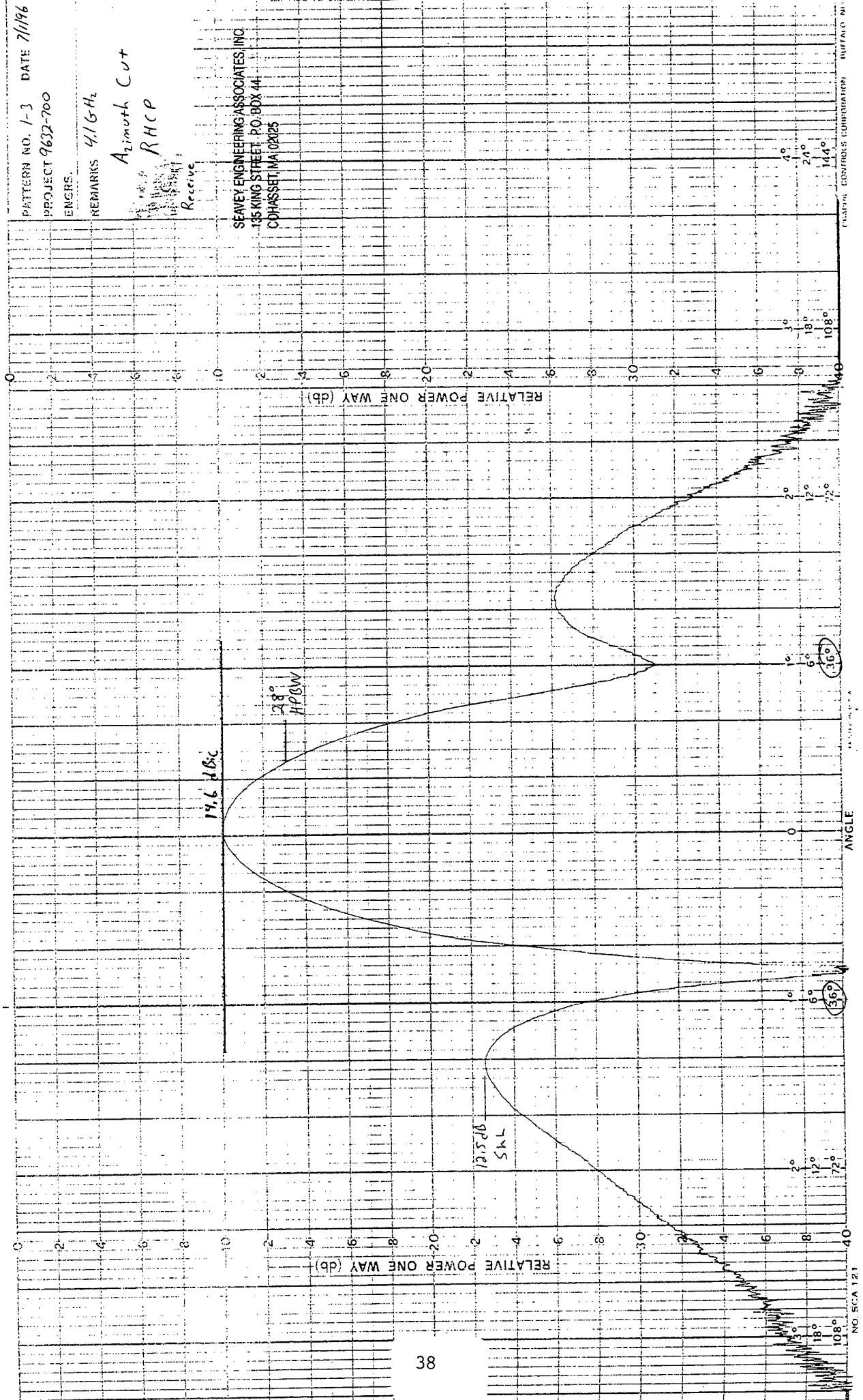

PATTERN NO. 1-4 DATE 7/1/96

PROJECT 9832-700

ENGRS.

REMARKS 4.1 G-H,

Elevation Cut

RHCP

Receive

SEAVEY ENGINEERING ASSOCIATES, INC.
135 KING STREET, PO BOX 74
CONASSET MA 02025

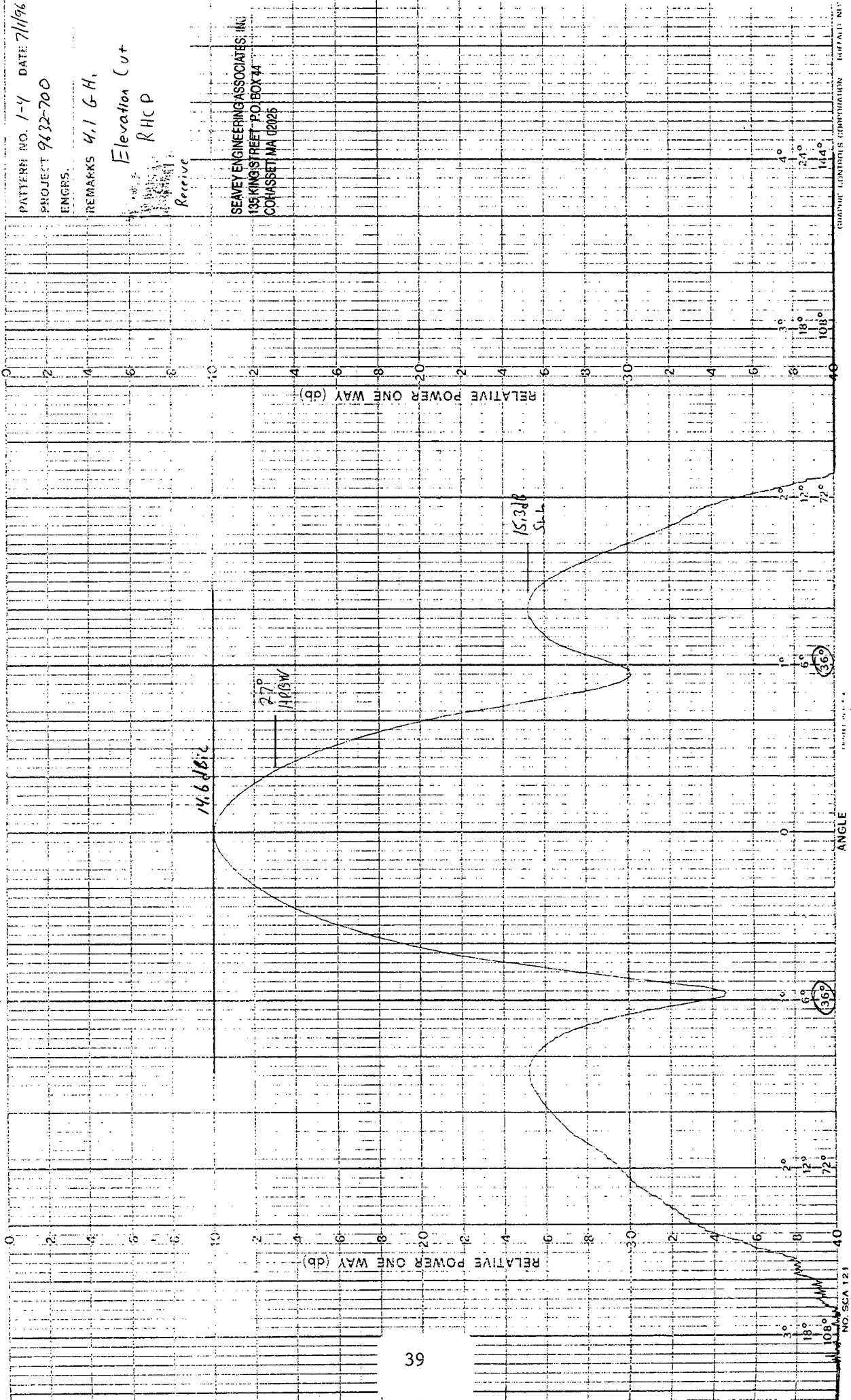

PATTERN NO. 1-5 DATE 7/1/96

PROJECT 9672-800

ENGRS.

REMARKS 4.2 GHz

Asimuth Cut

RHCP

Receive

SEAVEY ENGINEERING ASSOCIATES INC
135 KING STREET PO BOX 441
GROHASSETT MA 02025

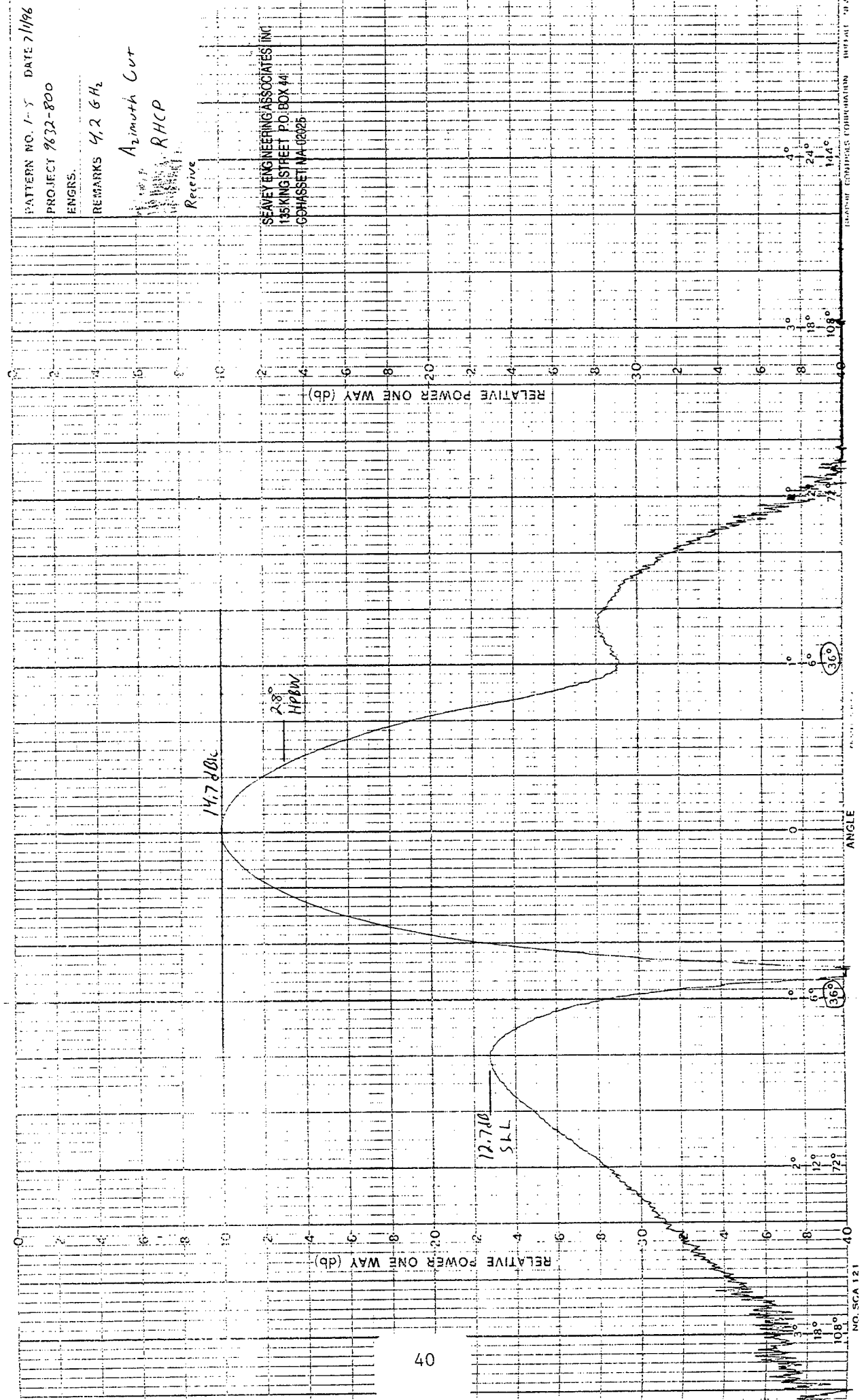

PATTERN NO. 1-6 DATE 7/1/6
 PROJECT 7632-700
 ENGRS.
 REMARKS 4,2 GHz

Elevation cut
 RHP

Receive

SEAVEY ENGINEERING ASSOCIATES, INC.
 135 KING STREET, P.O. BOX 44
 CONASSET, MA 02025

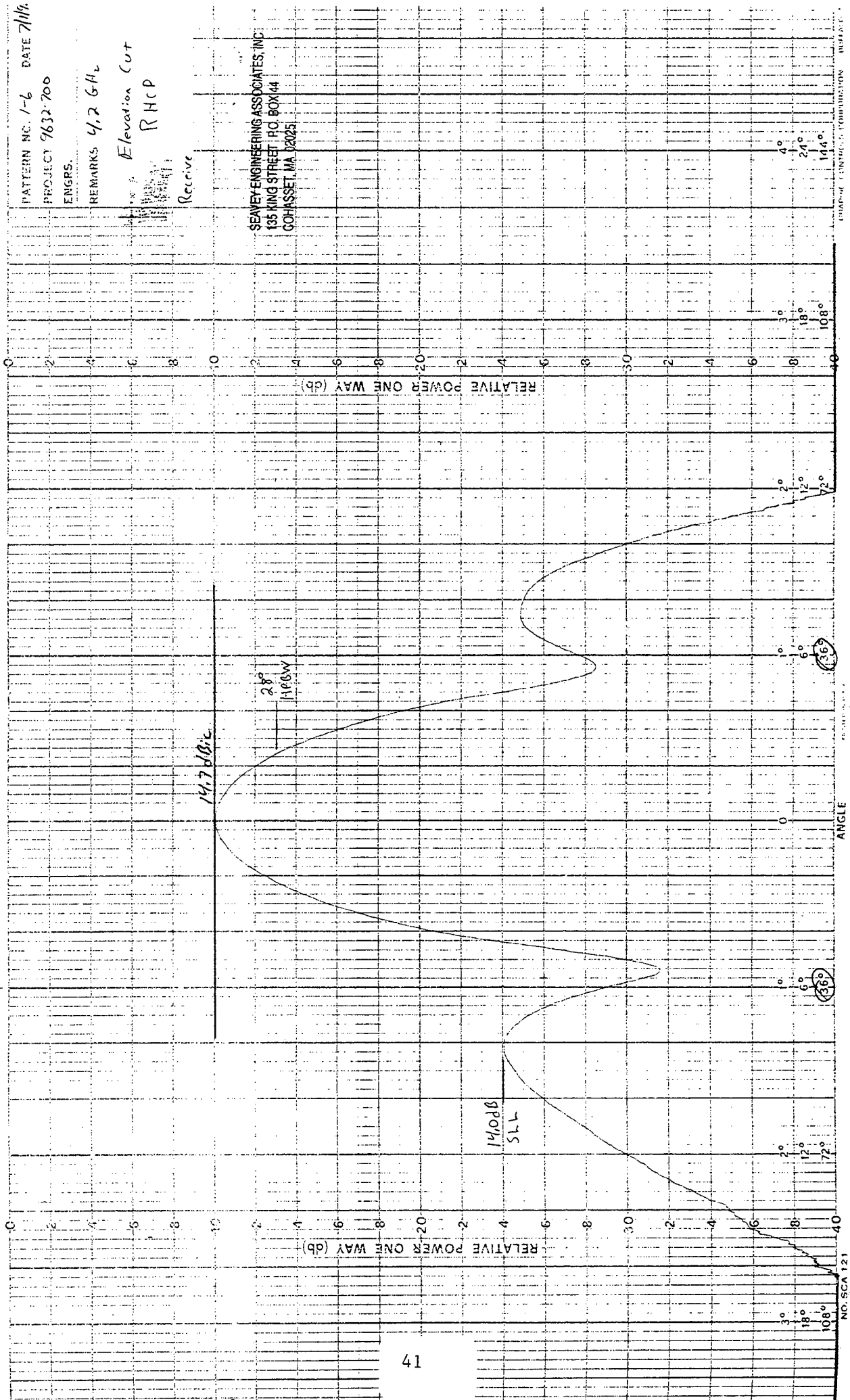

PATTERN NO. 1-7 DATE 7/1/96
PROJECT 9832-700
ENGRS.

REMARKS 6.25 GHz
Azimuth Cut
LHCP

Transmit

SEAVEY ENGINEERING ASSOCIATES INC
135 KING STREET P.O. BOX 44
CDHASSETT, MA 02025

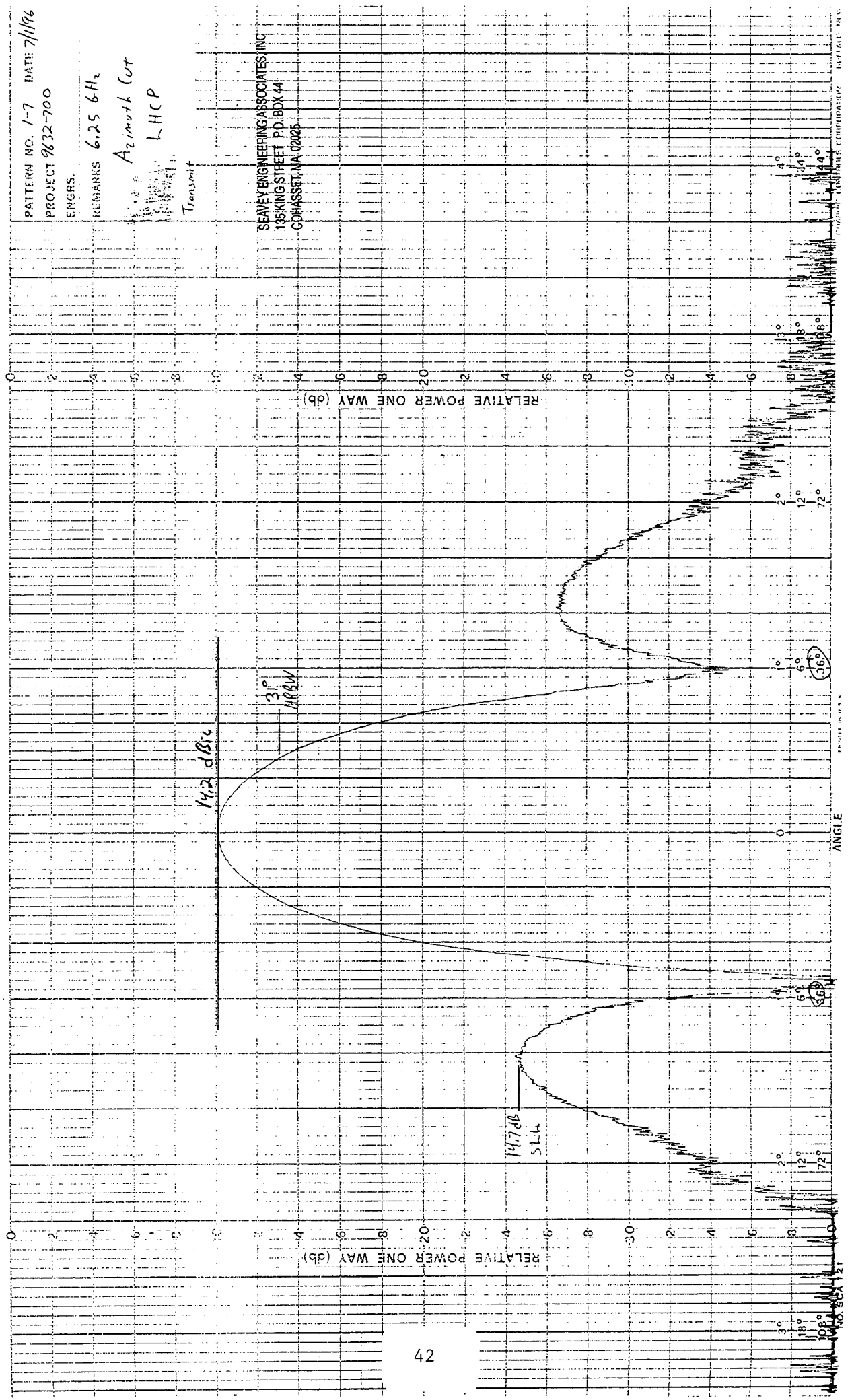

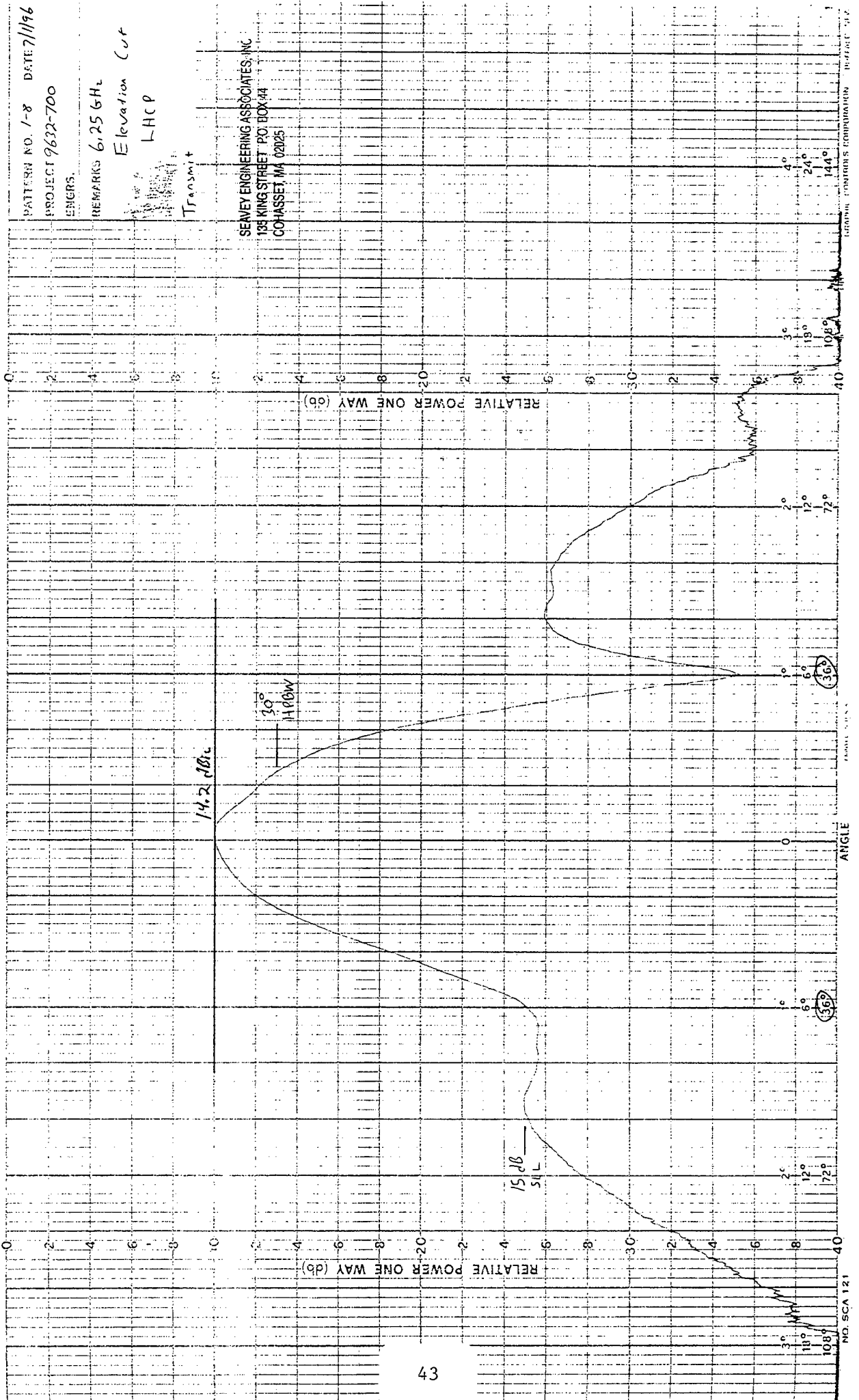

PATTERN NO. 1-8 DATE 7/1/96
 PROJECT 9632-700
 ENGRS.
 REMARKS 6.25 GHz
 Elevation Cut
 LHCP
 Transmit

SEAVEY ENGINEERING ASSOCIATES, INC.
 188 KING STREET P.O. BOX 44
 COHASSET, MA 02025

PATTERN NO. 1-9 DATE 7/1/96

PROJECT 9632-700

ENGRS.

REMARKS 6135 G-H_L

Azimuth Cut

HCP

Transmit

SEAVEY ENGINEERING ASSOCIATES, INC.
185 KING STREET, P.O. BOX 14
COHASSET, MA 02025

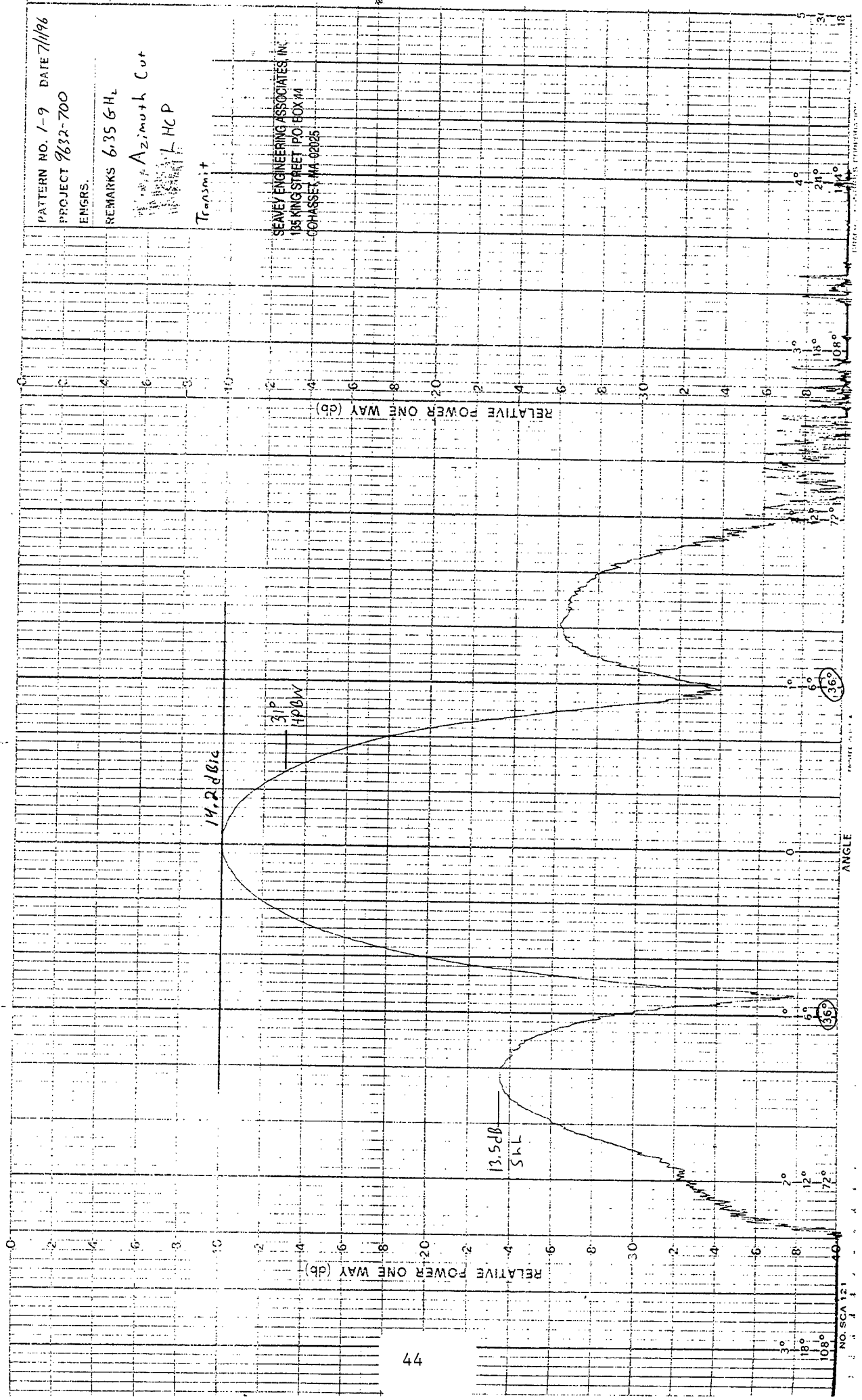

PATTERN NO. 1-10 DATE 7/1/96
 PROJECT 9632-700
 ENGRS.
 REMARKS 6.35 GHz

Elevation Cut
 L H C P
 Transmit

SEAVEY ENGINEERING ASSOCIATES, INC.
 135 KING STREET, P.O. BOX 441
 COMMASSET, MA 02025

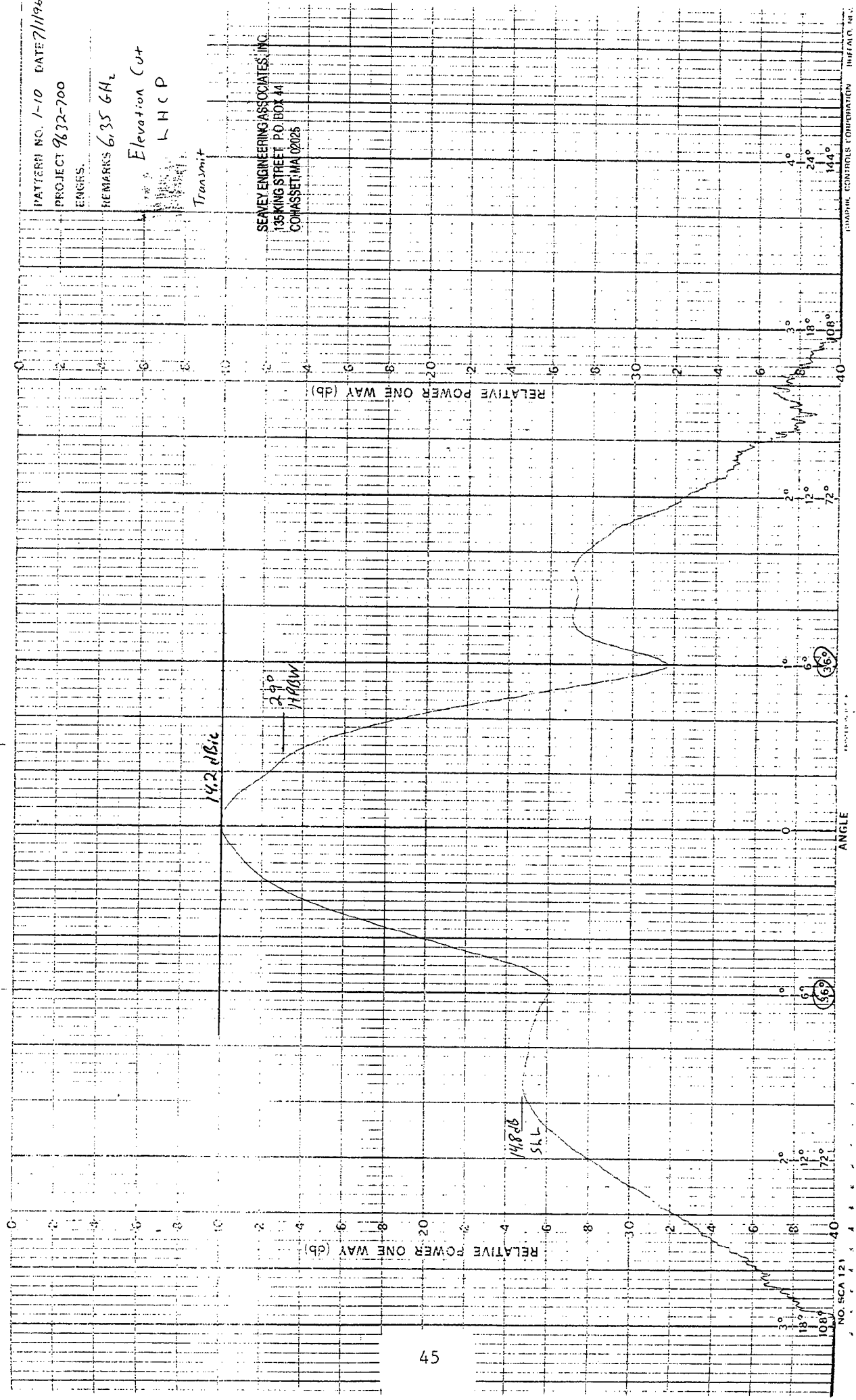

PATTERN NO. 1-11 DATE 7/1/96

PROJECT 9832-700

ENGRS.

REMARKS 6.45 G-H₂

Azimuth Cut

L HCP

Transmit

SEAVEY ENGINEERING ASSOCIATES, INC.
135 KING STREET P.O. BOX 14
COHASSET MA 02025

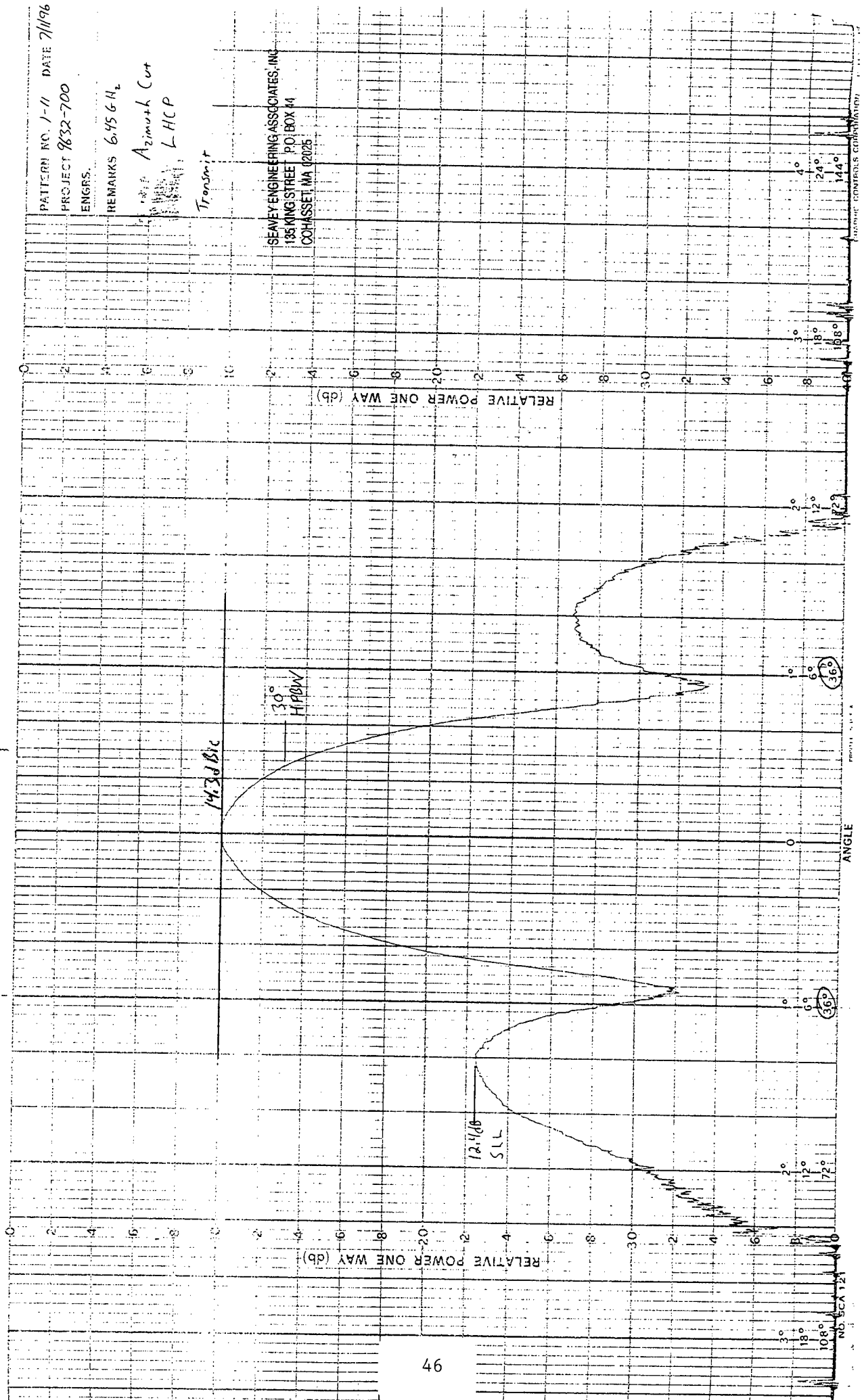

PATTERN NO. 1-12 DATE 7/11

PROJECT 7632-700

ENGRS.

REMARKS 6.45 6Hc

Elevation Cut
LHCP

Transmit

SEAVEY ENGINEERING ASSOCIATES, INC.
135 KING STREET, P.O. BOX 44
CONHASSET, MA 02025

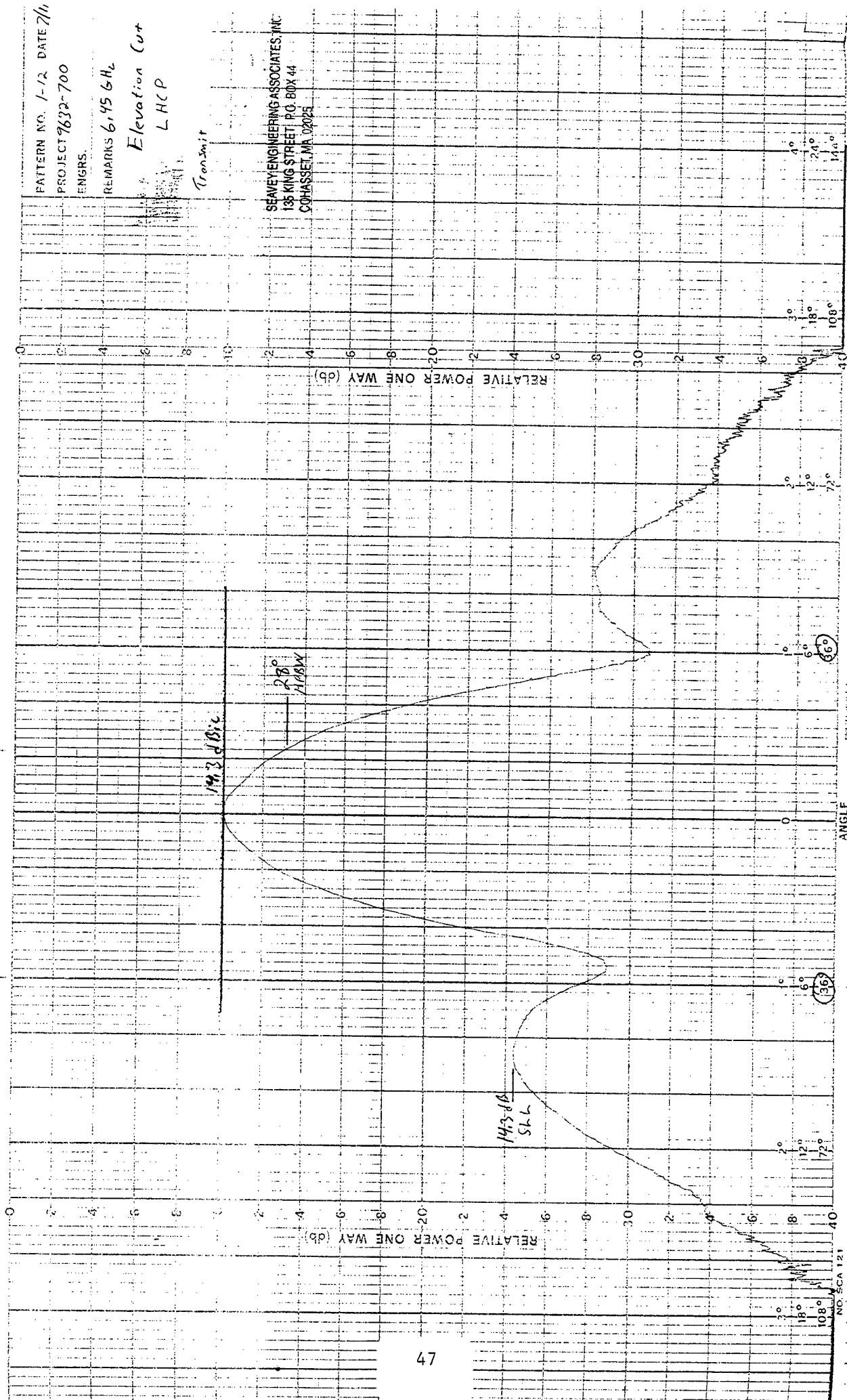

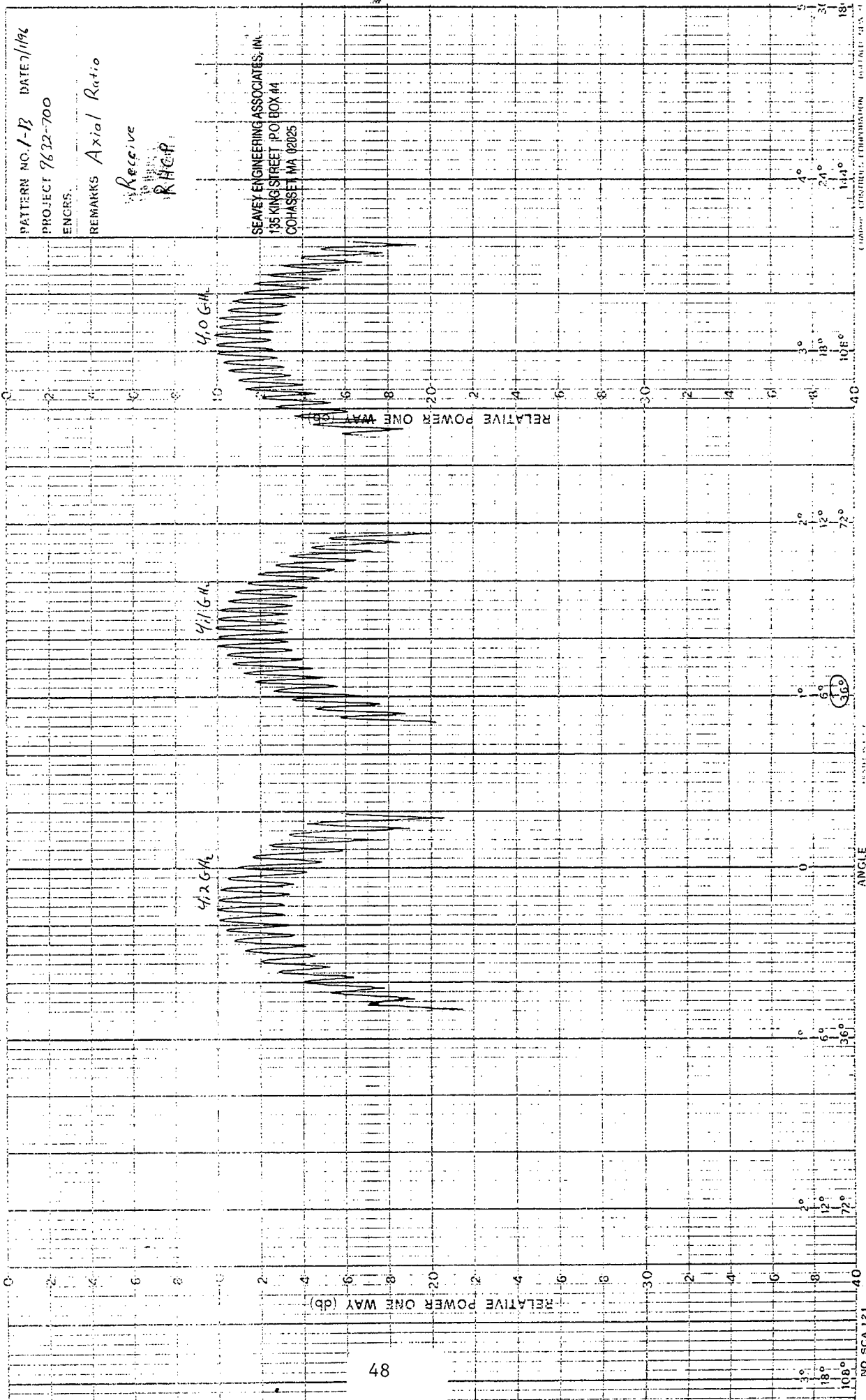

PATTERN NO. 1-14 DATE 7/1/96
PROJECT 9632-700
ENGRS.

REMARKS Axial Ratio

Transmit
HCP

SEAVEY ENGINEERING ASSOCIATES, INC.
135 KING STREET PO BOX 44
COHASSET WA 98025

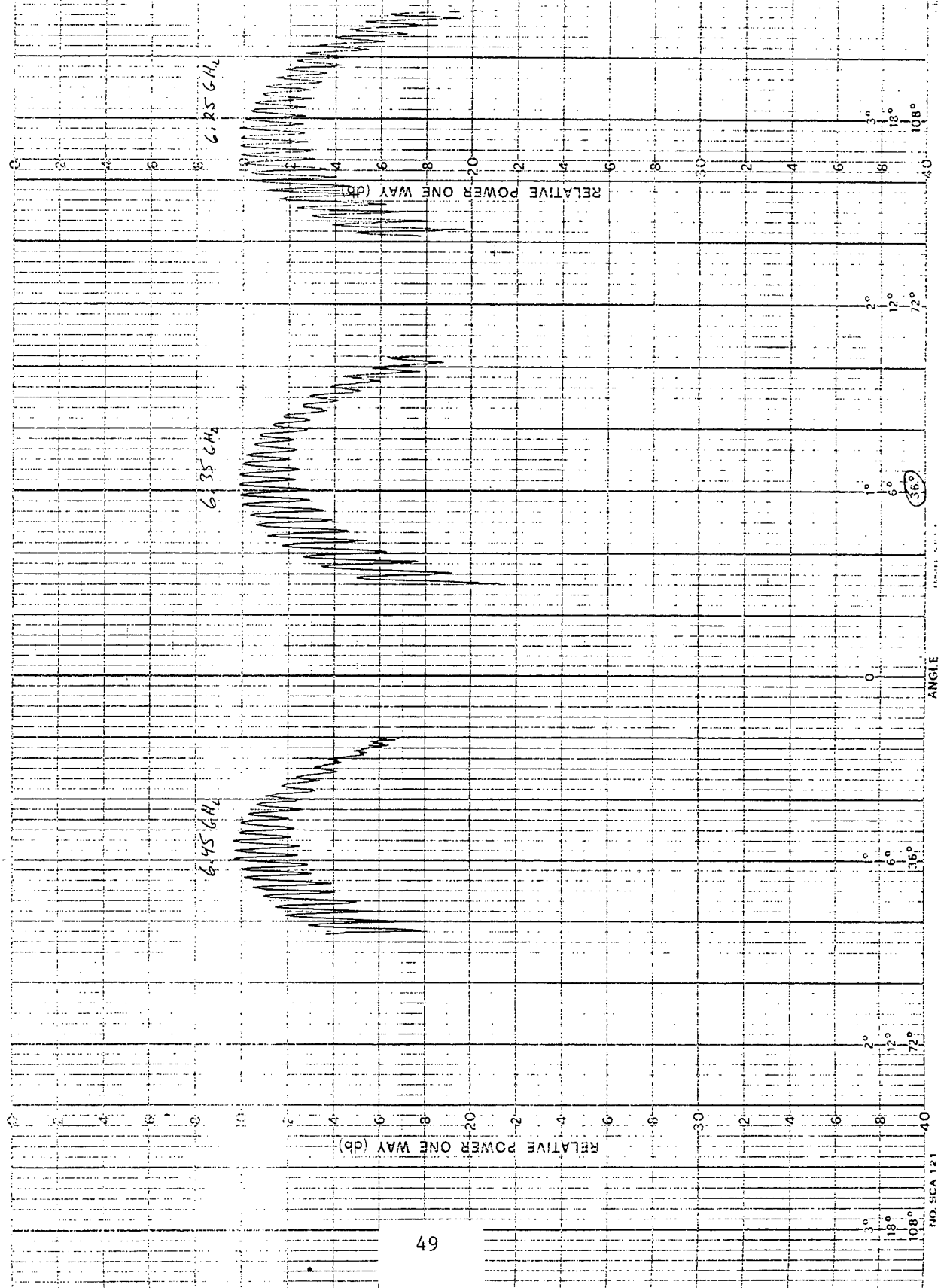

Test Conditions Return Loss Receive

CH2: R - 15.28 dB
5.0dB/ REF - .00 dB

Cust. P/N

Rx Port

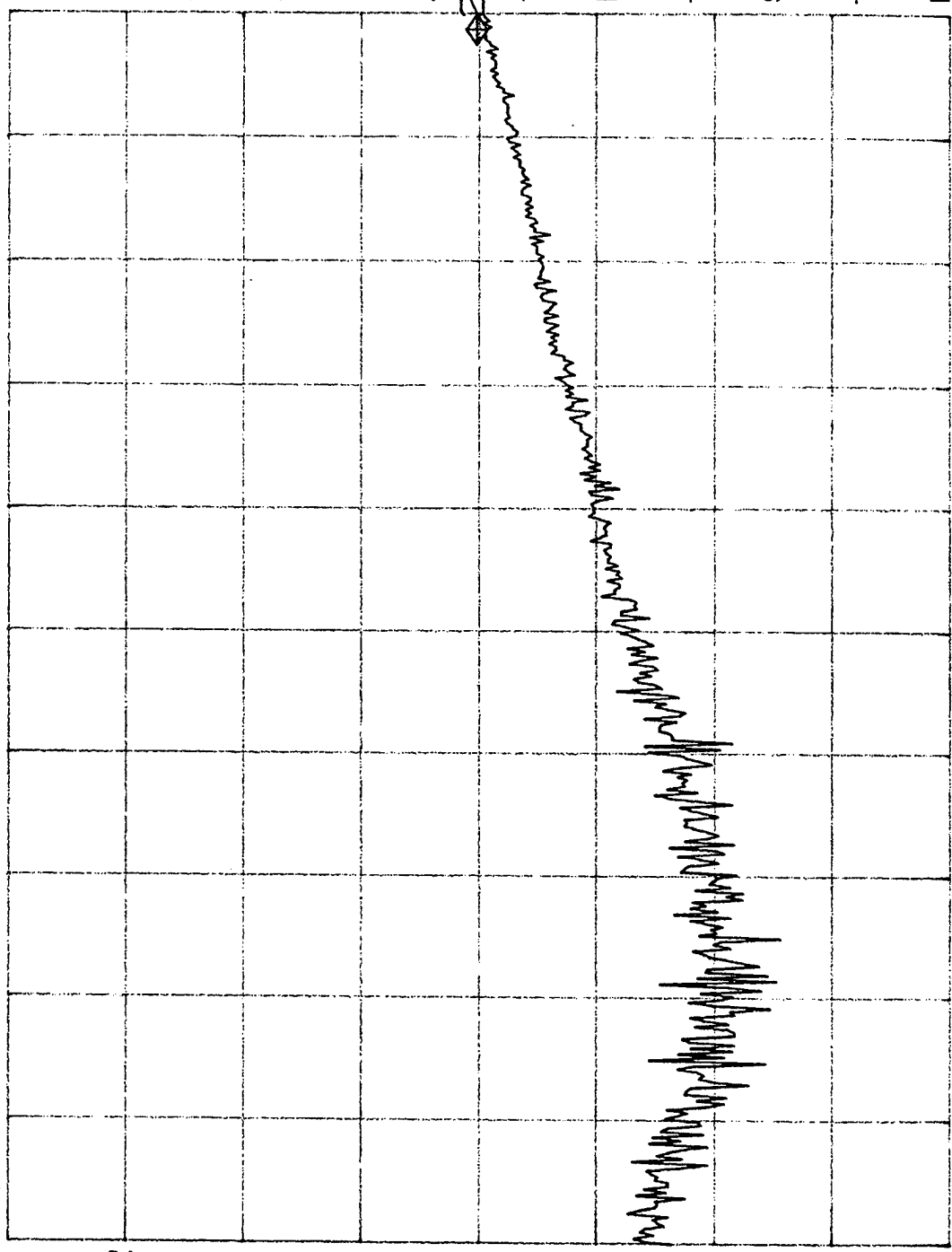

REF 2

Seavey P/N

9632-800

S/N

001

Date

7/11/96

Technician

PM

Inspector

Spec. Ref.

Report No. 9632-700

Figure No. 1-15

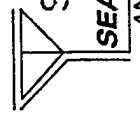

STRT +4.0000GHZ CRSR +4.1975GHZ STOP +4.2000GHZ
SEAVEY ENGINEERING ASSOCIATES, INC.
HEWLETT-PACKARD SCALAR NETWORK ANALYZER SYSTEM 8756A/S

ANTENNA DESIGN AND DEVELOPMENT

Return loss at ports

Insertion loss _____ between ports _____ and _____

Test Conditions Return Loss Transmit

CH2: R - 17.60 dB
5.0dB/ REF - .00 dB

Tx Port

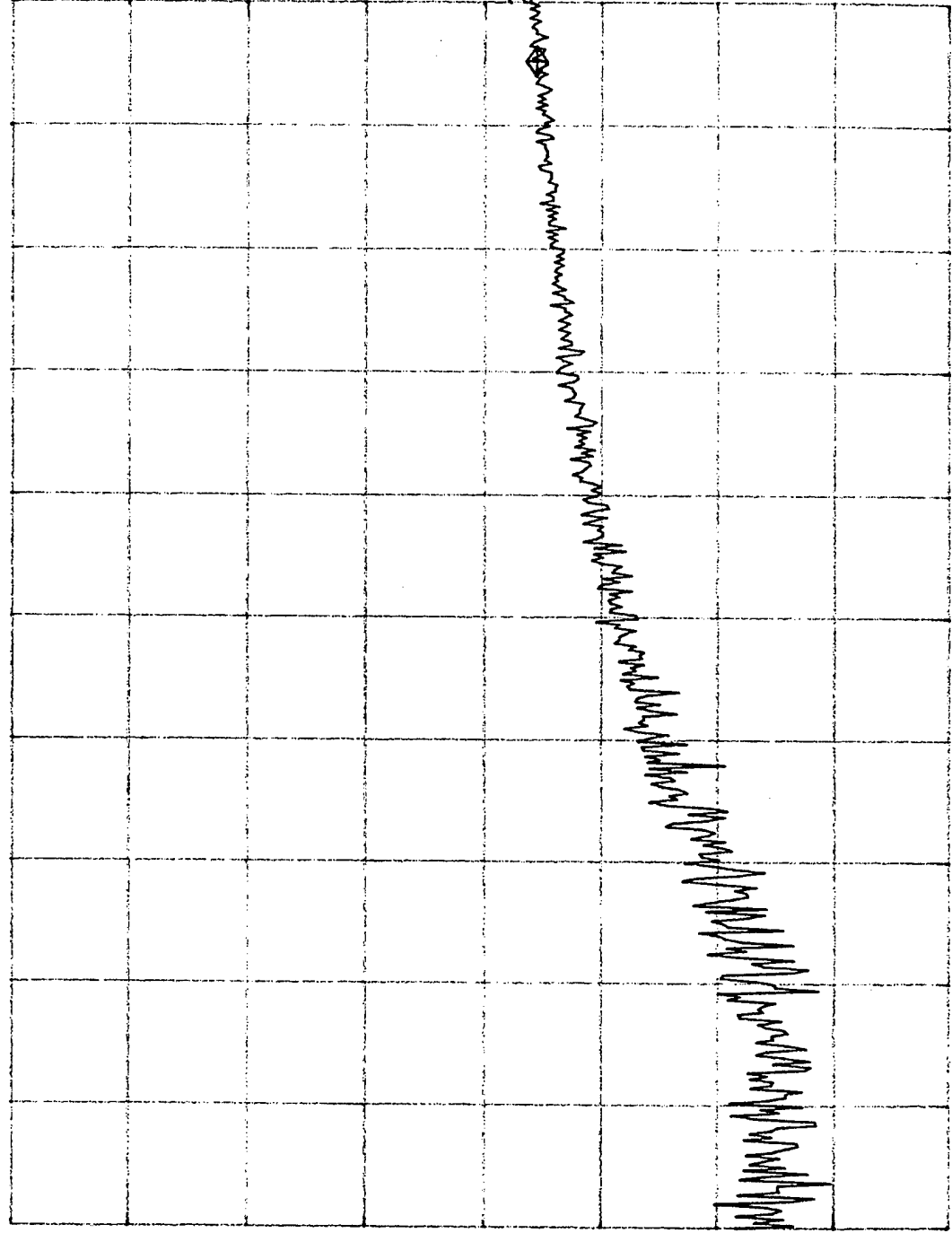

REF 2

Seavey P/N

7632-800

S/N 001

Date 7/11/96

Technician

PM

Inspector

Spec. Ref.

Report No. 9632-700

Figure No. 1-16

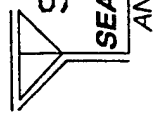

STRT +6.2500GHZ CRSR +6.4405GHZ STOP +6.4500GHZ
 SEAVEY ENGINEERING ASSOCIATES, INC.
 ANTENNA DESIGN AND DEVELOPMENT

HEWLETT-PACKARD SCALAR NETWORK ANALYZER SYSTEM 8756A/S

Return loss at ports and
 Insertion loss between ports and

Test Conditions Expanded Return Loss

CH2: R REF - 4.62 dB Cust. P/N
5.0dB/ REF - .00 dB

Rx Port

REF 2

Seavey P/N

2.9632-800

S/N 001

Date 7/11/96

Technician

PM

Inspector

Spec. Ref.

Report No. 9632-700

Figure No. 1-17

STOP +2.0000GHZ
HEWLETT-PACKARD SCALAR NETWORK ANALYZER SYSTEM 8756A/S

Return loss ✓ at ports _____ and _____
Insertion loss _____ between ports _____ and _____

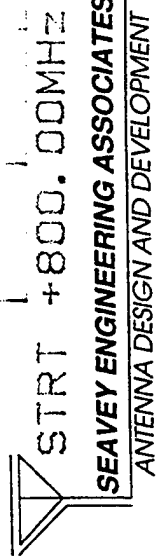

START +800.00MHZ
SEAVEY ENGINEERING ASSOCIATES, INC.
ANTENNA DESIGN AND DEVELOPMENT

Test Conditions Expanded Return loss

CH2: R - 23.05 dB
5.0dB/ REF - .00 dB

Cust. P/N

Rx Port

REF 2

Seavey P/N

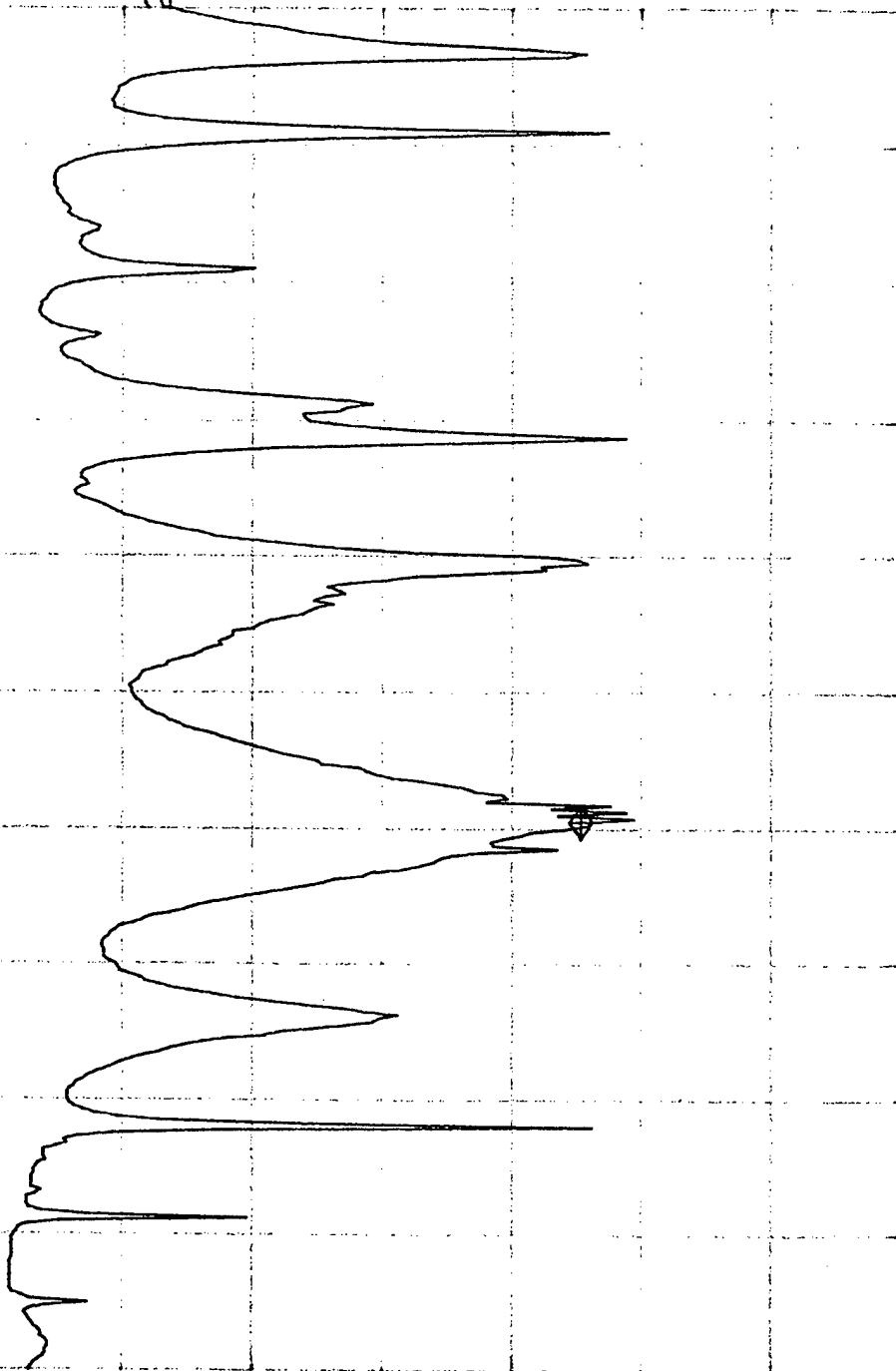

9632-800

S/N 001

Date 7/11/96

Technician

PM

Inspector

Spec. Ref.

STRT +2.0000GHZ CRSR +4.0250GHZ STOP +7.0000GHZ
HEWLETT-PACKARD SCALAR NETWORK ANALYZER SYSTEM 8756A/S

Report No. 9632-700

Figure No. 1-18

SEAVEY ENGINEERING ASSOCIATES, INC.
ANTENNA DESIGN AND DEVELOPMENT

Return loss 1 at ports _____ and _____
Insertion loss _____ between ports _____ and _____

Test Conditions Expanded Return loss

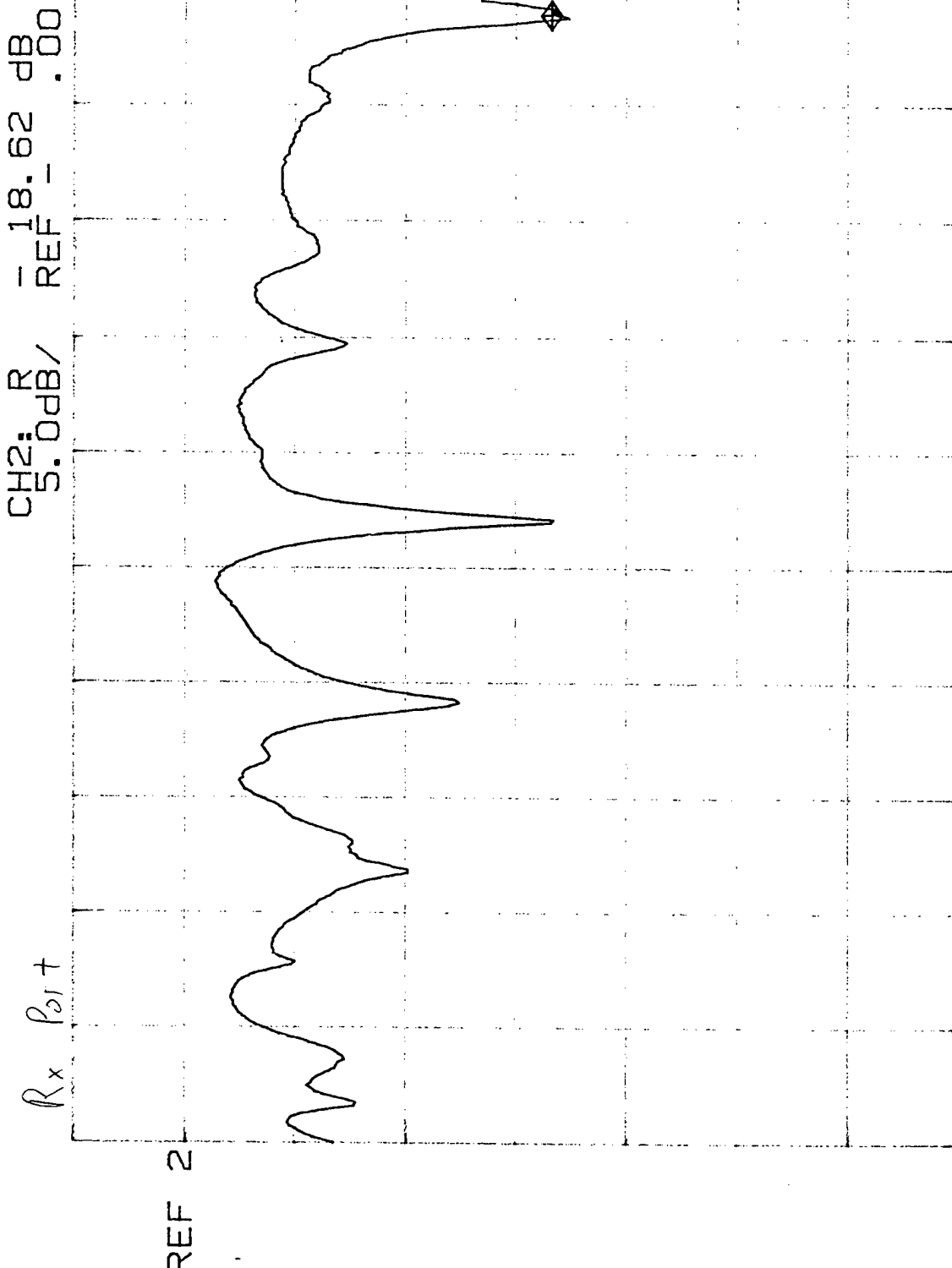

Seavey P/N 7632-800
S/N 001
Date 7/11/96
Technician PM
Inspector _____
Spec. Ref. _____

Report No. 7632-700
Figure No. 1-19

HEWLETT-PACKARD SCALAR NETWORK ANALYZER SYSTEM 8756A/S
Return loss at ports _____ and _____
Insertion loss _____ between ports _____ and _____

SEAVEY ENGINEERING ASSOCIATES, INC.
ANTENNA DESIGN AND DEVELOPMENT

Test Conditions Expanded Return loss

CH2: R - 7.69 dB Cust. P/N
5.0dB/ REF - .00 dB

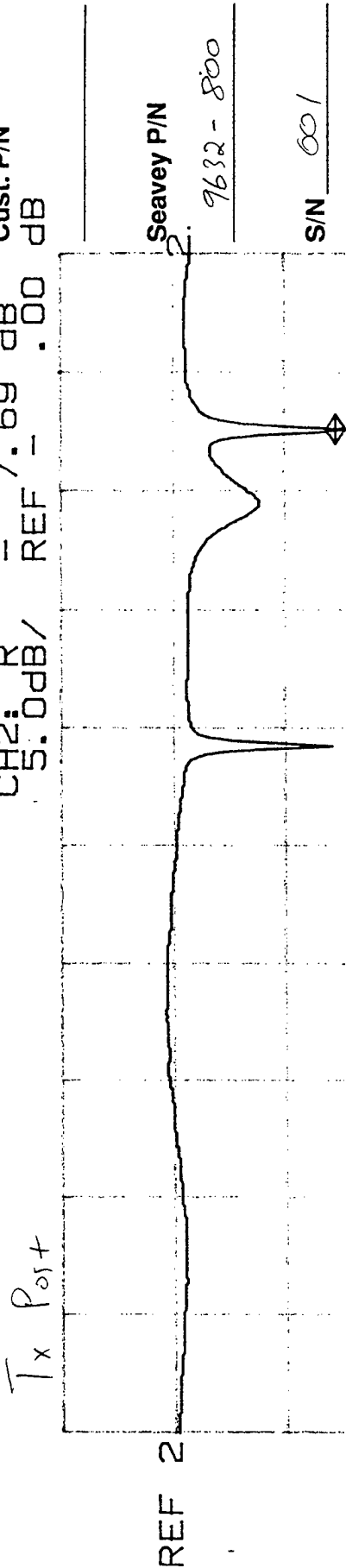

REF 2

Seavey P/N

9632-800

S/N 001

Date 7/11/96

Technician

PM

Inspector

Spec. Ref.

Report No. 9632-700

Figure No. 1-20

STRT +800.00MHz CRSR +1.8229GHz STOP +2.0000GHz
SEAVEY ENGINEERING ASSOCIATES, INC.
ANTENNA DESIGN AND DEVELOPMENT
HEWLETT-PACKARD SCALAR NETWORK ANALYZER SYSTEM 8756A/S
Return loss at ports _____ and _____
Insertion loss _____ between ports _____ and _____

Test Conditions Expanded Return Loss

CH2: R - 24.06 dB
5.0dB/ REF - .00 dB
Cust. P/N

Tx Port

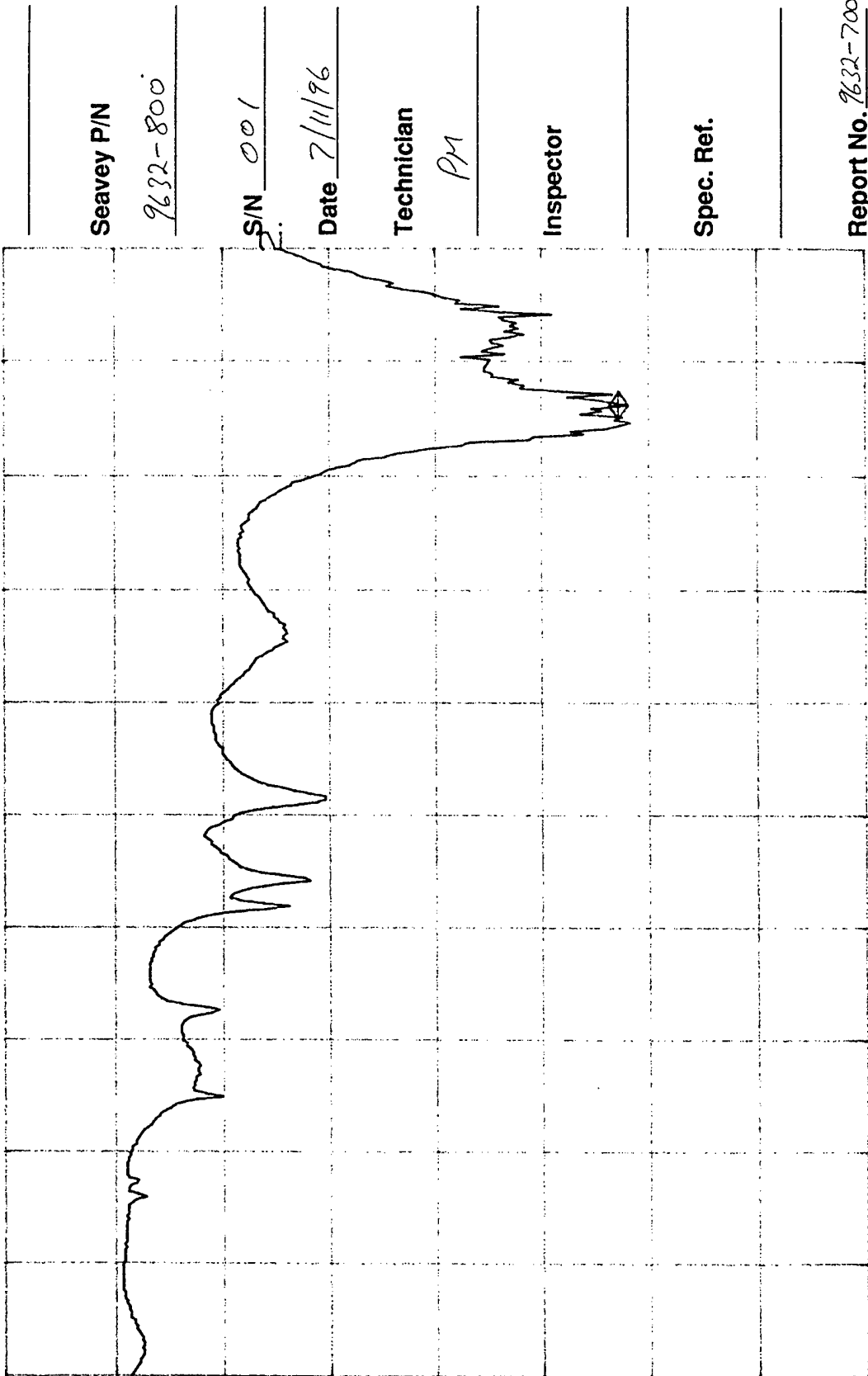

REF 2

Seavey P/N

7632-800

S/N 001

Date 7/11/96

Technician

PM

Inspector

Spec. Ref.

Report No. 7632-700

Figure No. 1-21

STRT +2.0000GHZ CRSR +6.3124GHZ STOP +7.0000GHZ
HEWLETT-PACKARD SCALAR NETWORK ANALYZER SYSTEM 8756A/S

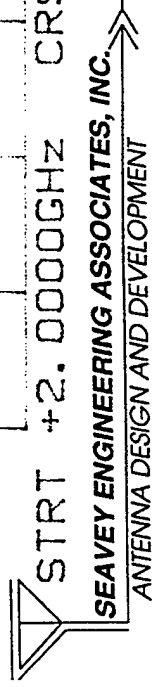

Return loss at ports
Insertion loss _____ between ports _____ and _____

Test Conditions Expanded Return loss

CH2: R - 22.19 dB
5.0dB/ REF - .00 dB

Cust. P/N

Seavey P/N

9632-800

S/N 001

Date 7/11/96

Technician PM

Inspector

Spec. Ref.

Report No. 9632-700

Figure No. 1-22

STRT +7.0000GHZ CRSR +11.162GHZ STOP +12.000GHZ

HEWLETT-PACKARD SCALAR NETWORK ANALYZER SYSTEM 8756A/S

SEAVEY ENGINEERING ASSOCIATES, INC.

ANTENNA DESIGN AND DEVELOPMENT

Return loss at ports

Insertion loss between ports and

Tx Port

REF 2



APPENDIX A

DOC. #ATP-9632-800
(4 Pages)

SEAVEY ENGINEERING ASSOCIATES, INC.
ACCEPTANCE TEST PROCEDURE

1.0 SCOPE

This procedure is to be used for testing of Model #9632-800 LHCP transmit / RHCP receive single plane printed circuit antenna.

2.0 RELATED DOCUMENTS

- S.E.A. Outline Drawing # 9632-800

3.0 RANGE TESTS

3.1 SCOPE

Radiation patterns will be generated and gain and axial ratio tests performed. Tests are to be performed at Seavey Engineering.

3.2 TEST SETUP

The antenna is to be placed on an elevation-over-azimuth antenna test pedestal located in the anechoic test chamber.

The received signal is to be recorded using a Scientific Atlanta antenna test instrumentation receiver and a rectangular chart recorder, or a network analyzer.

Refer to the block diagrams shown in Section 5.0 for details.

3.3 TEST FREQUENCIES

Unless otherwise specified, tests are to be performed at:

RECEIVE BAND: 4.0, 4.1, and 4.2 GHz

TRANSMIT BAND: 6.25, 6.35 and 6.45 GHz

3.4 RADIATION PATTERNS

Co-polarized radiation patterns are to be generated for the complete antenna assembly.

Patterns are to be generated in the azimuth and elevation planes at each of the frequencies listed in section 3.3 for a total of 12 radiation patterns.

Refer to Figure 1 for test setup. Refer to Figure 3 for orientation of the antenna.

3.4.1 HALF POWER BEAMWIDTHS

HPBW must be 30° minimum on all patterns.

SEAVEY ENGINEERING ASSOCIATES, INC.
ACCEPTANCE TEST PROCEDURE

3.5 GAIN

Record gain data in the transmit and receive bands by the substitution technique, using a Standard Gain Horn and a precision RF attenuator inserted in the test antenna signal path to minimize the dynamic range of the measurement.

Gain is to be measured in the receive band and the transmit band at the frequencies listed in Section 3.3, above. Equipment will be set up according to Figure 2 (block diagram), shown in Section 5.0.

3.5.1 REQUIREMENTS

RECEIVE BAND - Minimum Gain is 14.0 dBic.

TRANSMIT BAND - Minimum Gain is 14.0 dBic.

3.6 AXIAL RATIO

3.6.1 SCOPE

Axial ratio is to be taken on boresight at the frequencies listed in section 3.3 using a rotating linear source at an approximate distance of 20 feet. Maximum axial ratio is 4.0 dB in both bands.

3.6.2 PROCEDURE

- 3.6.2.1- Equipment will be set up according to Figure 2 (block diagram), shown in Section 5.0.
- 3.6.2.2- Set the frequency to be measured on the signal source. Use a frequency counter as a reference.
- 3.6.2.3- Turn on the polarization rotator to rotate the linear source. Record the swept axial ratio at beam peak.
- 3.6.2.4- The unit under test is acceptable if the axial ratio at beam peak is not greater than 4.0 dB.
- 3.6.2.5- Note the test frequency and the unit's serial number on the data plot.
- 3.6.2.6- Repeat the sequence for each frequency and port to be tested.

SEAVEY ENGINEERING ASSOCIATES, INC.
ACCEPTANCE TEST PROCEDURE

4.0 VSWR (RETURN LOSS)

4.1 SCOPE

Swept return loss tests for all test sequences will be performed for 1.5:1 maximum V.S.W.R. as follows:

BAND	MIN FREQ	MAX FREQ	MIN RETURN LOSS
RECEIVE	4.0 GHz	4.2 GHz	14.0 dB
TRANSMIT	6.25 GHz	6.45 GHz	14.0 dB

4.2 PROCEDURE

4.2.1- Set up the test equipment as shown below.

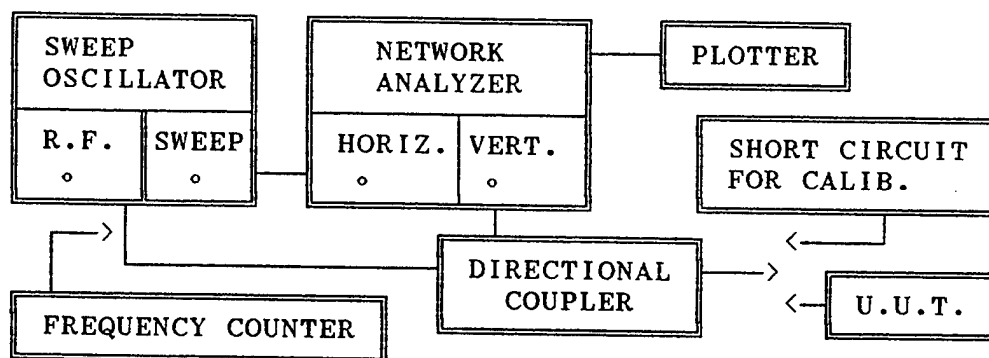

- 4.2.2- Set the frequency band to be measured by setting the Start/Stop controls on the Sweep Oscillator for the MIN and MAX frequencies for the frequency band to be tested per the table above. Use a frequency counter as a reference.
- 4.2.3- Place the short on the end of the directional coupler and set the zero reference on the network analyzer.
- 4.2.4- Remove the short.
- 4.2.5- Put the unit under test on the end of the directional coupler and observe the trace on the network analyzer.
- 4.2.6- The unit under test is acceptable if the return loss is greater than or equal to 14.0 dB.
- 4.2.7- Record the trace with a plotter. Note the port tested and the serial number of the unit under test on the data plot.

SEAVEY ENGINEERING ASSOCIATES, INC.
ACCEPTANCE TEST PROCEDURE

5.0 TEST SETUP ILLUSTRATIONS

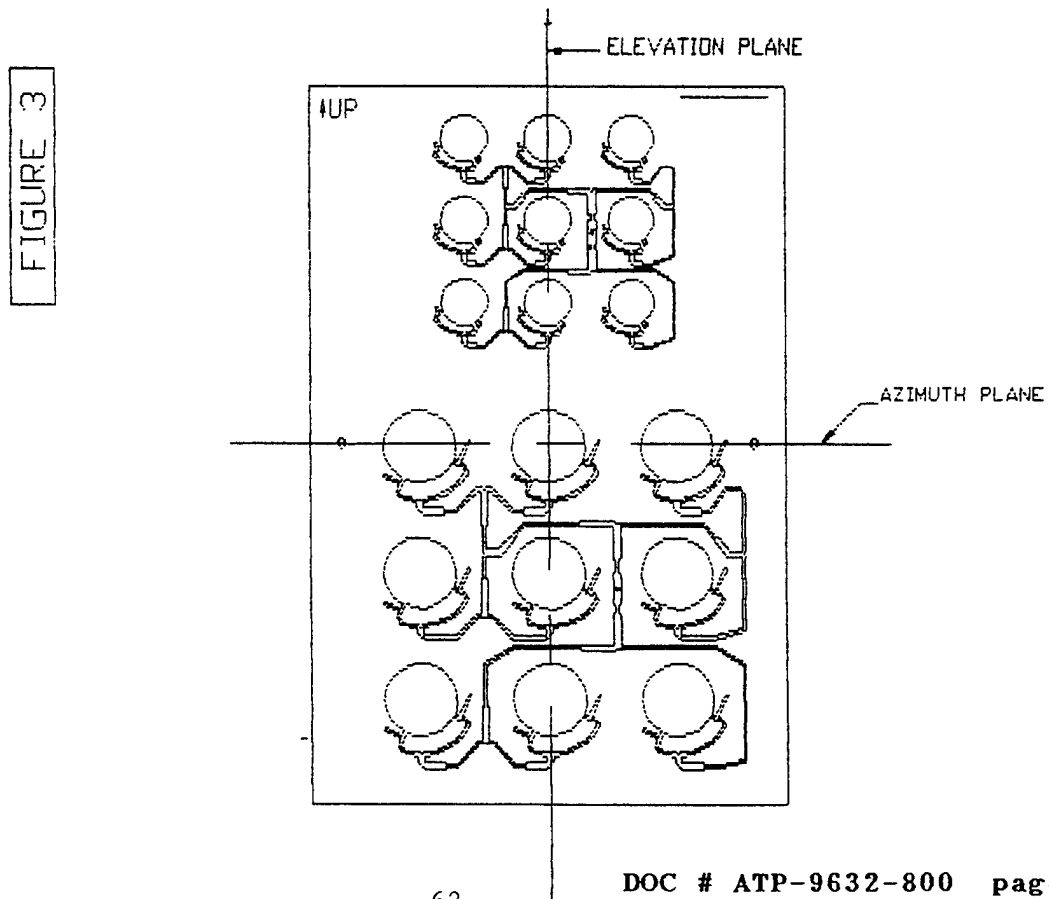
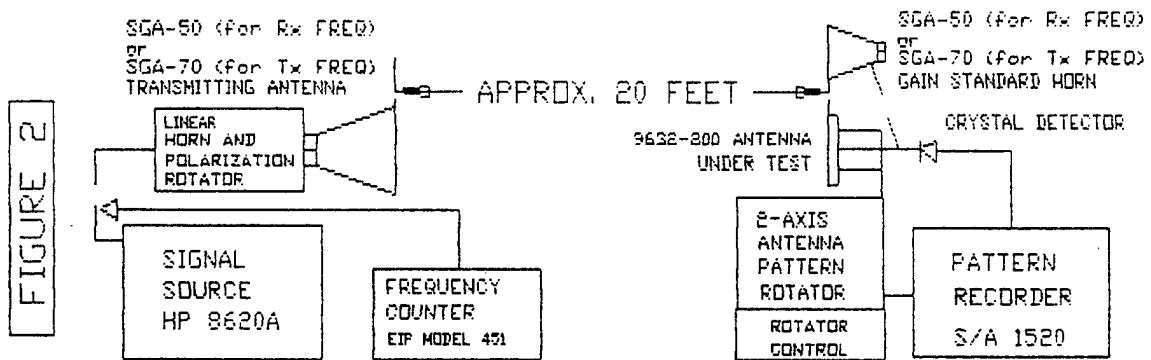
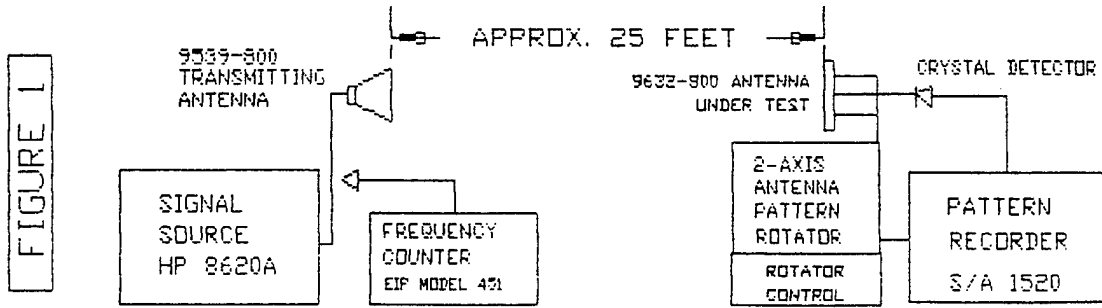

APPENDIX B

OUTLINE DRAWING NO. 9632-800
REV. B

DO NOT SCALE PRINT

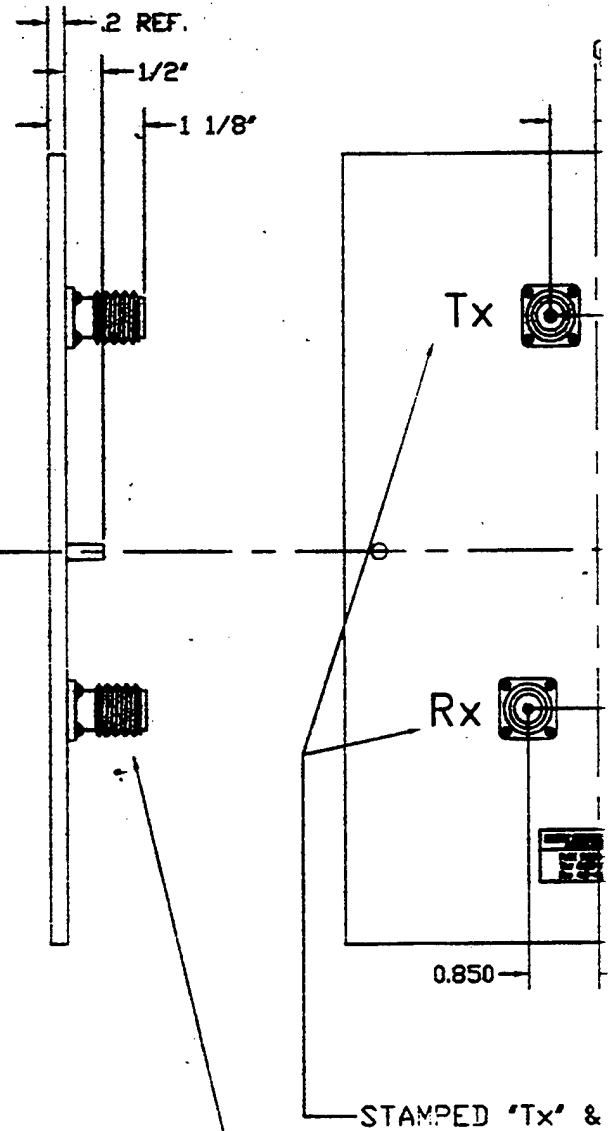
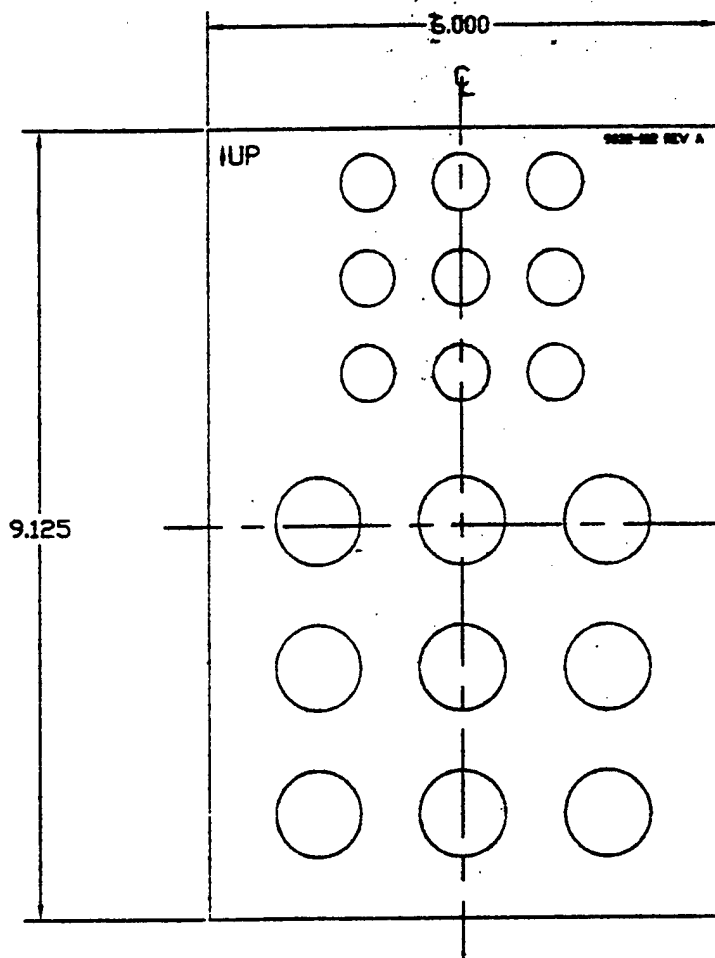

SPECIFICATIONS:	
FREQUENCY:.....	Rx: 4.0-4.2 GHz Tx: 6.25-6.45 GHz
POLARIZATION:.....	Rx: RHCP Tx: LHCP
GAIN:.....	Rx: 14.0 dBic NOMINAL Tx: 14.0 dBic NOMINAL
HPBW:.....	Rx: 30° Az & EL Tx: 30° Az & EL
VSWR:.....	1.5:1 GOAL
AXIAL RATIO:.....	4.0 dB MAX.
SIZE:.....	9.125" x 6.00"
WEIGHT:.....	6 OZ.(EST)

SMA FEMALE CONNECTORS (2)

REVISIONS					
THIS DRAWING WAS ORIGINALLY ISSUED UNDER EGM # 2373					
ECN#	REV	DESCRIPTION	DONE BY	DATE	APPROVED
2484	A	ORIG. ISSUE	PM	6-11-96	PM
2530	B	CORRECTION ON LABEL	WM	7-15-96	PM

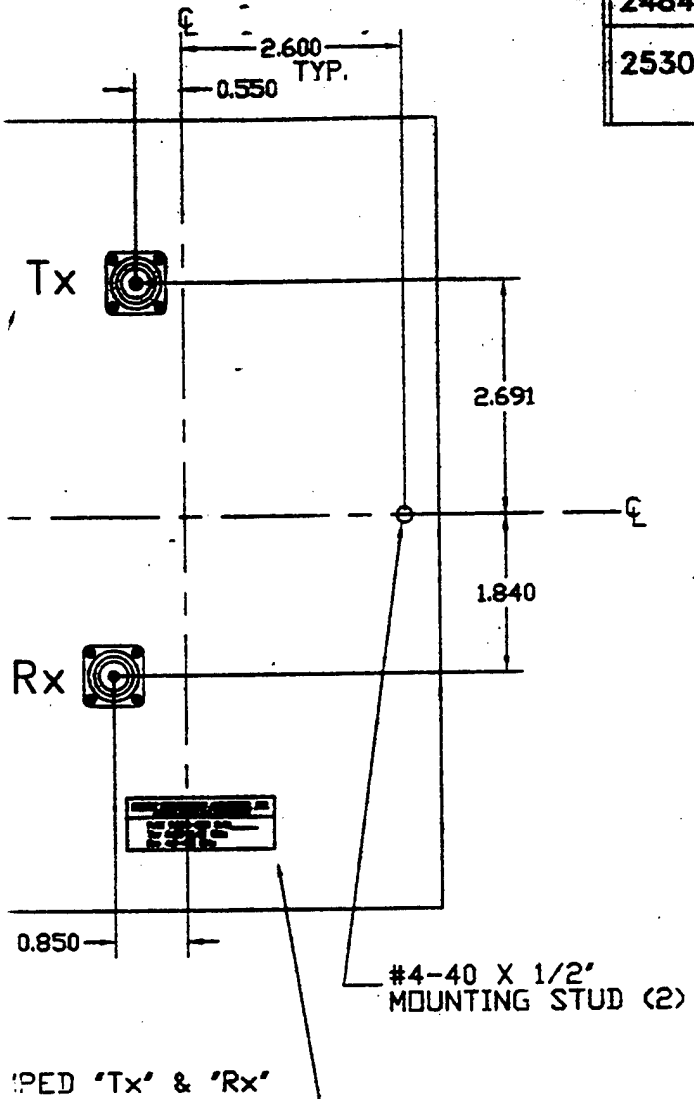

SEAVEY ENGINEERING ASSOCIATES, INC.
 P/N 9632-800 S/N
 Tx: 6.25-6.45 GHz
 Rx: 4.0-4.2 GHz

SEAVEY LABEL

NEXT ASSY.		USED ON	
MADE FROM:			
FINISH			
RUSTOLEUM HARD HAT #2124 SAFETY BLUE			
MATERIAL			
1/16" TEFLON GLASS 1/8" POLYURETHANE FOAM 3 MIL MYLAR SINGLE SIDED 1 Oz COPPER ELECTROLESS TIN PLATE			
UNLESS OTHERWISE SPECIFIED DIMENSIONS ARE IN INCHES			
TOLERANCES:			
FRACTIONS ±1/16"	DECIMALS ±1/2"	DECIMALS X = ±.000 XX = ±.010 XXX = ±.005	
 SEAVEY ENGINEERING ASSOCIATES, INC. CORUSETT, MA. 02025			
TITLE			
30° HPBW C-BAND BUOY REDL PRINTED CIRCUIT ARRAY			
DRAWN:	PM	DATE	6-11-96
CHECKED:		DATE	
ENGR. APPD:	F. Medeiros	DATE	7-16-96
QA APPD:		DATE	
SIZE	FSCM NO.	DWG NO.	REV
B	60173	9632-800	B
SCALE 1=2	WT.	SHEET	1 OF 1

DOCUMENT LIBRARY

Distribution List for Technical Report Exchange - September 1997

University of California, San Diego
SIO Library 0175C
9500 Gilman Drive
La Jolla, CA 92093-0175

Hancock Library of Biology & Oceanography
Alan Hancock Laboratory
University of Southern California
University Park
Los Angeles, CA 90089-0371

Gifts & Exchanges
Library
Bedford Institute of Oceanography
P.O. Box 1006
Dartmouth, NS, B2Y 4A2, CANADA

NOAA/EDIS Miami Library Center
4301 Rickenbacker Causeway
Miami, FL 33149

Research Library
U.S. Army Corps of Engineers
Waterways Experiment Station
3909 Halls Ferry Road
Vicksburg, MS 39180-6199

Institute of Geophysics
University of Hawaii
Library Room 252
2525 Correa Road
Honolulu, HI 96822

Marine Resources Information Center
Building E38-320
MIT
Cambridge, MA 02139

Library
Lamont-Doherty Geological Observatory
Columbia University
Palisades, NY 10964

Library
Serials Department
Oregon State University
Corvallis, OR 97331

Pell Marine Science Library
University of Rhode Island
Narragansett Bay Campus
Narragansett, RI 02882

Working Collection
Texas A&M University
Dept. of Oceanography
College Station, TX 77843

Fisheries-Oceanography Library
151 Oceanography Teaching Bldg.
University of Washington
Seattle, WA 98195

Library
R.S.M.A.S.
University of Miami
4600 Rickenbacker Causeway
Miami, FL 33149

Maury Oceanographic Library
Naval Oceanographic Office
Building 1003 South
1002 Balch Blvd.
Stennis Space Center, MS, 39522-5001

Library
Institute of Ocean Sciences
P.O. Box 6000
Sidney, B.C. V8L 4B2
CANADA

National Oceanographic Library
Southampton Oceanography Centre
European Way
Southampton SO14 3ZH
UK

The Librarian
CSIRO Marine Laboratories
G.P.O. Box 1538
Hobart, Tasmania
AUSTRALIA 7001

Library
Proudman Oceanographic Laboratory
Bidston Observatory
Birkenhead
Merseyside L43 7 RA
UNITED KINGDOM

IFREMER
Centre de Brest
Service Documentation - Publications
BP 70 29280 PLOUZANE
FRANCE

REPORT DOCUMENTATION PAGE	1. REPORT NO. WHOI-97-16	2.	3. Recipient's Accession No.
4. Title and Subtitle Design and Evaluation of a Directional Antenna for Ocean Buoys			5. Report Date November 1997
7. Author(s) Daniel Frye, Ken Doherty, and Al Hinton			6.
8. Performing Organization Rept. No. WHOI-97-16			
9. Performing Organization Name and Address Woods Hole Oceanographic Institution Woods Hole, Massachusetts 02543			10. Project/Task/Work Unit No.
			11. Contract(C) or Grant(G) No. (C) (G)
12. Sponsoring Organization Name and Address			13. Type of Report & Period Covered Technical Report
			14.
15. Supplementary Notes This report should be cited as: Woods Hole Oceanog. Inst. Tech. Rept., WHOI-97-16.			
16. Abstract (Limit: 200 words) A system concept has been developed by Viasat, Inc. and Woods Hole Oceanographic Institution for improving the data telemetry bandwidth available on ocean buoys. This concept utilizes existing communications satellites as data relay stations and mechanically steered antenna arrays to achieve increased data rates and improved power efficiency needed for ocean applications. This report describes an initial feasibility and design study to determine if a mechanically steered antenna array can meet the requirements of open ocean buoy applications. To meet the system requirements, an 18-element microstrip antenna (9-element transmit, 9-element receive) was designed and fabricated under subcontract by Seavey Engineering Associates, Inc. It operates in the 4-6 GHz frequency band (C-band) and provides 14 dB of gain. the 1/2 power beamwidth is $\pm 15^\circ$ in azimuth and elevation. This antenna design, in conjunction with a simple rotating mount, was used to evaluate the potential of this approach to keep a geostationary satellite in view when mounted on an ocean buoy. The evaluation is based on laboratory measurements using a magnetic compass and a small stepper motor to maintain antenna orientation while the complete assembly was rotated and tilted at speeds similar to what would be expected on an offshore buoy equipped with a stabilizing wind vane. The results are promising, but less than conclusive because of limitations in the experimental test setup. The recent introduction of several commercially available mechanically steered antennas designed for use on small boats may provide a viable alternative to the approach described here with appropriate modification to operate at C-band.			
17. Document Analysis a. Descriptors ocean data telemetry directional antenna satellite telemetry b. Identifiers/Open-Ended Terms c. COSATI Field/Group			
18. Availability Statement Approved for public release; distribution unlimited.		19. Security Class (This Report) UNCLASSIFIED	21. No. of Pages 68
		20. Security Class (This Page)	22. Price