

**Russian Federal Nuclear Center
All-Russian Scientific Research Institute of
Experimental Physics**

Deputy Scientific Leader

Mokhov V.N. Mokhov
21.09 1995.

**COMPARATIVE ANALYSIS OF MOST POWERFUL
MODERN OPENING SWITCHES AND PLASMA
FLOW SWITCHES.**

(Part 2. Final report. Subcontract F 6170894W0757).

SPC-94-4075

19980303 138

DTIC QUALITY INSPECTED 3

607200 Arzamas-16, Nizhny Novgorod region., RF.

1995

DISTRIBUTION STATEMENT A
Approved for public release;
Distribution Unlimited

REPORT DOCUMENTATION PAGE

Form Approved OMB No. 0704-0188

Public reporting burden for this collection of information is estimated to average 1 hour per response, including the time for reviewing instructions, searching existing data sources, gathering and maintaining the data needed, and completing and reviewing the collection of information. Send comments regarding this burden estimate or any other aspect of this collection of information, including suggestions for reducing this burden to Washington Headquarters Services, Directorate for Information Operations and Reports, 1215 Jefferson Davis Highway, Suite 1204, Arlington, VA 22202-4302, and to the Office of Management and Budget, Paperwork Reduction Project (0704-0188), Washington, DC 20503.

1. AGENCY USE ONLY (Leave blank)		2. REPORT DATE 1995	3. REPORT TYPE AND DATES COVERED Final Report	
4. TITLE AND SUBTITLE Comparative Analysis of Most Powerful Modern Opening Switches and Plasma Flow Switches			5. FUNDING NUMBERS F6170894W0757	
6. AUTHOR(S) Prof. Vladislav Mokhov				
7. PERFORMING ORGANIZATION NAME(S) AND ADDRESS(ES) Institute of Experimental Physics Prospekt Mira 37 Arzamas-16 Russia Russia			8. PERFORMING ORGANIZATION REPORT NUMBER N/A	
9. SPONSORING/MONITORING AGENCY NAME(S) AND ADDRESS(ES) EOARD PSC 802 BOX 14 FPO 09499-0200			10. SPONSORING/MONITORING AGENCY REPORT NUMBER SPC 94-4075	
11. SUPPLEMENTARY NOTES				
12a. DISTRIBUTION/AVAILABILITY STATEMENT Approved for public release; distribution is unlimited.			12b. DISTRIBUTION CODE A	
13. ABSTRACT (Maximum 200 words) This report results from a contract tasking Institute of Experimental Physics as follows: Perform a comparative study of advanced opening switches and plasma flow switches using 1D calculations, theoretical analysis and estimations using existing experimental data.				
14. SUBJECT TERMS Nil			15. NUMBER OF PAGES 31	
			16. PRICE CODE N/A	
17. SECURITY CLASSIFICATION OF REPORT UNCLASSIFIED	18. SECURITY CLASSIFICATION OF THIS PAGE UNCLASSIFIED	19. SECURITY CLASSIFICATION OF ABSTRACT UNCLASSIFIED	20. LIMITATION OF ABSTRACT UL	

TABLE OF CONTENTS.

INTRODUCTION.....	4
1. EXPLODED OPENING SWITCHES.....	6
1.1.Current circuit break using ribbed dielectric barrier.....	6
1.2.Current circuit break using cumulative jets.....	8
1.3.Opening switch based on electric arc quenching with HE detonation products.....	10
2. ELECTRO - EXPLODED FOIL FUSE OPENING SWITCH (FOS).....	12
3. MOVING CONDENSED LINER AS AN OPENING SWITCH.....	14
4. COMPARISON AND DISCUSSION OF VARIOUS OPENING SWITCH TYPES.....	17
REFERENCES.....	22

INTRODUCTION.

Many modern physical experiments with pulsed systems (liners, pinches, pulsed systems for thermonuclear research, electron beams, X - ray pulse generation systems, etc.) require the use of high pulsed power electromagnetic energy sources. One of the ways to increase pulsed power is development of high - speed current opening switches capable to commutate multimegaampere currents and secure the multiterawatt power level. In this review we will outline the principle of operation and give basic experimental results for several switch types: 3 exploded switch types, an electro - exploded foil switch and a liner switch.

When considering the above switch types, we mainly used the results of development of these switches at VNIIEF, therefore, this review does not pretend to be complete.

Section 1 is devoted to exploded switches. Within the multimegaampere current exploded switches three techniques for sharp increase in switch resistance are studied: 1) the mechanic conductor break technique based on casting metal foil onto a ribbed barrier made of dielectric [1]; 2) the technique based on foil cutting using dielectric cumulative jets [2]; 3) the technique based on arc discharge quenching with detonation products (DP) [3, 4].

All these techniques use condensed chemical explosives (HE) favorably combining mechanic and electric properties. High pressure and high sound speed of DP behind the detonation front promote fairly high mechanic speed of operation of the switches. Quite low DP conductance ($\sim 1 \text{ Ohm}^{-1} \text{ cm}^{-1}$) which, moreover, rapidly reduces behind the detonation front, in combination with high density and high electric strength (up to $\sim 100 \text{ kV/cm}$) promotes relatively high rate of switch operation as a whole ($\sim 10^{-6} \text{ sec}$) under condition of high voltages ($10^5 + 10^6 \text{ V}$) and intense joule heating.

Section 2 considers the electro - exploded switch whose principle of operation is based on the phenomenon of multiple (~ 100 and more times) increase in resistance of copper foil at its electric burst. This switch type is well known and widely used in various electrophysical facilities (see, for example, [5]). Such a

switch was tested in VNIIEF experiments with disk explosive - magnetic generator (DEMG) in the axisymmetric form at 60 - 90 MA currents and achieved power level of up to ~ 10 terawatt [6, 7, 8].

Section 3 considers the liner opening switch with a liner in condensed state. This opening switch was developed and experimentally tried at VNIIEF in 1981 in a DEMG test at ~ 70 MA current [9]. An aluminium cylindrical liner was accelerated to ~ 10 km/s velocity not reaching the evaporated state and being almost of its initial thickness (~ 1 mm). Such a switch transferred more than 2 MJ of energy to the load.

All the switches considered in Sections 1, 2, 3 are oriented to the use in EMG experiments. Speed of operation of all of them is ~ 10^{-6} s.

Section 4, final, compares the considered opening switch types with plasma flow switches [10, 11]. Opening switches are distinguished which currently are record - holders in most important parameters. Thus, a record - holder in speed of operation (0.25 μ s) is the plasma flow opening switch developed and successfully tested at Phillips Laboratory. A record - holder in voltage (~ 1.2 MV) is the arc discharge quenching switch. A record - holder in linear current density (~ 0.9 MA/cm) is the liner switch. A record - holder in energy transferred to a load and in switch power (~ 10MJ and ~ 10 TW, respectively) is the electro - exploded and record - holder in total current (~ 85 MA) is the exploded switch with a ribbed barrier. Section 4 also discusses most important physical features of the opening switches under consideration, features of liner loads in terms of efficiency of energy transfer through the switch and potentials for further improvement of opening switches. It is concluded that the line of works on rapid opening switches of the plasma flow type, as well as on opening switches of the compact toroid type is of quite a significant future potential.

1. EXPLODED OPENING SWITCHES.

1.1. Current circuit break using ribbed dielectric barrier.

The scheme of the device where current - carrying foil is broken at its casting onto a ribbed dielectric barrier using HE is shown in FIG. 1. As a broken conductor aluminium (or copper) is most frequently used. Cross section of the conductor being broken is selected from the relation [8]

$$S_{\phi} = \left[\int_0^{t^*} I^2(t) dt / A \right]^{1/2},$$

where $I(t)$ - current flowing in the opening switch; A - specific integral of current action when the conductor is yet in solid state; t^* - the time of opening switch actuation. Initial conductor resistance (up to the time of the break) is therewith quite small and practically does not affect EMG operation. For aluminium conductors the value $A = 2.5 \cdot 10^8 \text{ A}^2 \cdot \text{s} / \text{cm}^4$ is taken.

After the foil break the gaps between foil sections are filled with DP and foil electric explosion products. The law of resistance increase at opening switch operation mainly depends on conductance of plasma filling these gaps. This law, according to paper [8], is close to exponential. Time dependence of resistance is found by experimental results if currents $I_1(t)$ and $I_2(t)$ in EMG and the load are measured and load inductance, L_2 , is known. These data are used to compute current $I(t) = I_1(t) -$

$I_2(t)$ flowing through the switch, switch voltage $U(t) = L_2 \frac{dI_2}{dt}$

and switch resistance $R(t) = \frac{U(t)}{I(t)}$. Naturally, in each test not the whole curve $R(t)$, but only its part corresponding to the time of principal EMG and load current smoothing can be found using this technique. At later times when the difference in currents $I_1(t)$ and $I_2(t)$ becomes comparable with the measurement error of the currents themselves the error in estimation of current $I(t)$ and resistance becomes excessively large.

Indirectly the exponential character of resistance growth is also confirmed by other experimental data [8]. First, very weak (apparently, logarithmic) dependence of the time of current increase in the load on the absolute value of EMG and load inductances is observed (at the time of switch actuation their ratio, as a rule, is selected equal to 1). Second, in the tests where the load was not connected the 1.8 - 2.0 times increase in voltage amplitude was noted at the opening switch as compared to the tests where the inductive load was connected. Explain the last statement. From the solution of the electrotechnical equations it follows that for the strictly exponential law of resistance growth the voltage maximum becomes exactly 2 times higher if one transfers from the case of equal inductances to the case of infinitely high inductance of the load. Hence, the above fact of double voltage counts in favor of the exponential law of resistance growth. At the same time, certain care is required in comparing the results of operation of one and the same switch under different conditions. For example, if there is no any load, twice as much joule heat is released in the switch as in the case of equal inductances. For this reason the laws of switch resistance growth can differ in these two cases, while agreement with the above theoretic result can be a consequence of other causes. Indeed, if the law resistance growth did not depend on the joule heat amount, then one might expect decrease in the time of current growth in the load at load connection at some time delay. However, the experiments did not show such a decrease [8]. It testifies for the severe effect of the current flowing in the switch on switch resistance and for the need of further research into this issue.

As an example of the use of the switch under consideration we give the results of three experiments noticeably differing in scale [8]. In these experiments aluminium foil 0,15; 0,23 and 0,37 mm thick was used for the broken portion in cylindric opening switches. Helical EMG's with helix inside diameter of 50, 80 and 160 mm were used where current of 1, 2.8 and 8.5 MA amplitude, respectively, occurred. The time of current pulse generation in the load was 0.5; 1.0 and 1.5 μ s. Hence, for the monoblock design increase in EMG and opening switch diameter leads to increase in the time of current - to - load commutation. In order to increase current being broken and retain the time of

switch operation, an experiment was performed where EMG and the opening switch were made of ten parallel-connected cylindric modules 160 mm in diameter [8]. Through each module current of 8.5 MA amplitude flew, through the entire opening switch that of 85 MA. Thickness of the broken conductor in a module equaled 0.37 mm. In the coaxial load common for all the modules ~ 50 MA amplitude current pulse was generated during the time approximately equal to the time of load current generation at a single module.

Note that the module commutator structure allows to have ~ 3 times less total system diameter than in the monoblock version [8].

There is also an improved version of the above opening switch with a ribbed barrier where metal laps are additionally located on the dielectric barrier ribs [13]. This improvement allows to successfully break thicker foils without decrease in switch rate of operation and is used at linear current density of more than ~ 0,1 MA/cm.

It should be noted that exploded switches with a dielectric barrier are also being studied at LANL (see, for example, [25]).

1.2. Current circuit break using cumulative jets.

The scheme of the opening switch based on current-carrying conductor cutting with cumulative dielectric jets is given in Fig. 2. After explosion of HE charge 1 cumulative hollows of dielectric block 2 collapse and current-carrying foil 3 is simultaneously cut in many cross sections with cumulative jets which then intrude at some depth in dielectric 4 located from the other side of foil extending the current circuit. The principle of operation of such opening switches is suggested in [14]. The results of further research are published in papers [2, 8, 12].

Efficiency comparison of foil break using dielectric cumulative jets and on the basis of foil casting onto a ribbed barrier showed that for aluminium conductors up to 0,4 mm in thickness both the techniques lead to commutators of approximately equal rate of operation. For foil more than 0,4 mm

in thickness the cumulative technique turns out to be more efficient. Application of cumulative opening switches allows to use conductors up to 1 mm in thickness and obtain load current pulses of microsecond rise time at conductor current density of up to 0.4 MA/cm and more [8].

Linear current density effect on cumulative opening switch resistance was experimentally studied. The experiments were performed at linear current density within the 0.06 – 0.4 MA/cm range with cylindric geometry opening switches. As conductor to be broken aluminium foil 1 mm thick was used. The experiment results show that opening switch resistance vary approximately in inverse proportion to linear current density.

A specific example of cumulative opening switch application is the helical EMG and opening switch 200 mm in diameter [8]. EMG provides current up to ~ 25 MA in ~ 30 nH inductance (~ 10 MJ energy). Using the cumulative opening switch operating in the mode of linear current density of ~ 0.4 MA/cm, in the load of ~ 35 nH inductance a current pulse up to ~ 10 MA amplitude and 2 – 2.5 μ s rise time is generated. This explosive magnetic source with an opening switch 200 mm in diameter was used in a set of MAGO plasma chamber experiments, in particular, in the collaborative (VNIIEF – LANL) experiment performed at Los Alamos in October, 1994.

Self – inductance of explosive opening switches can be a reason restricting their use in low – inductive systems. Self – inductance of opening switches can be reduced either using module design at parallel module connection or by decreasing gaps between opening switch current conductors. Presence of HE charge within the EMG circuit or the load circuit does not allow to reduce opening switch self – inductance down to the minimum. To solve this problem, the HE charge should be located outside the EMG or load current circuit. In cumulative opening switches this possibility can be implemented. In one of the developed systems [8] a cumulative opening switch was designed where opening switch self – inductance was reduced by about a factor of 3 thanks to HE charge location outside EMG and load current circuits.

1.3. Opening switch based on electric arc quenching with HE detonation products.

For rapid switch of superheavy currents exploded plasma flow switches can be used which are based on rapid build-up of resistance of the plasma channel imploded with HE detonation products. Possibility of rapid evolution of dense plasma instabilities in combination with high pressure produced by explosion products in the region of electric field generation secures high-speed operation and high electric strength of the opening switch under the conditions of high power and dissipated energy concentration. Exploded plasma flow switches were studied in papers [3, 4, 15 - 19]. As an example, Figs. 3 and 4 give schemes of exploded plasma flow switches from papers [15, 16].

As the experiments on plasma-arc channel implosion with HE detonation products and their theoretic analysis show [18, 19], resistance of an imploded arc turns out to be considerably higher than theoretically computed. It results from interaction of the pushing piston (HE detonation products) with arc plasma. Their interface appears to be instable. Evolving instabilities lead to arc plasma mixing with relatively cold detonation products. The compressed arc is laced up into thin filaments whose resistance is much higher than that of quietly burning arc. Such a mechanism of arc plasma cooling leading to complete arc disintegration allows to dissipate electric power fed to the opening switch which is about two orders of magnitude higher than power in an undisturbed arc. Commutator resistance increases more than by a factor of 100.

In paper [15] for ignition of homogeneous surface plasma channel a lvsan film with sprayed aluminium about 100 Angstrom thick was used. At the rise phase of current flowing through the switch the voltage across the plasma channel is practically constant being of the order of several kilovolts. During the process of switch operation the voltage peak is, as a rule, triangular in shape and reaches the amplitude of $\sim 10^6$ V. Paper [15] gives the results of plasma channel resistance measurement at high current densities (up to $\sim 10^6$ A/cm²). The resistance appeared to be mainly depended on the integral of current action, $B = \int J^2(t) dt$. This dependency appeared to be

unique up to the values $B = 4 \cdot 10^{14} \text{ A}^2 \cdot \text{s} / \text{m}^4$ and is represented in the form of the formula

$$\rho = (12 \cdot 10^{-5} + 4 \cdot 10^8 / B)$$

Here ρ – specific resistance of plasma [*Ohm* · *m*]. It is also found that noticeable effect on commutator characteristics is exerted by the state of the dielectric barrier surface on which the plasma channel is pressed first by the magnetic field and then by the HE detonation products. Apparently, a ribbed surface promotes channel compression inhomogeneity, development of instabilities and acceleration of plasma mixing with detonation products. When a dielectric barrier with a smooth surface is used, the effective time of current switch to the load increases (up to a factor of ~ 1.5). A more severe change in switch characteristics resulted from insertion of a polyethylene gasket 5 mm thick precluding direct contact of detonation products and plasma. The switch time therewith increased by a factor of 3 – 5. Thus, rapid current switch occurs under the condition of direct contact of detonation products with the plasma channel which secures effective turbulent mixing leading to accelerated discharge plasma cooling.

Give specific parameters of the switch under consideration in several experiments.

1. Paper [3] gives switch parameters under the conditions: EMG inductance at the time of current opening is 38 nH, load inductance is 30 nH, current being broken is 7.3 MA. In the system load current of 4 MA with the rise time of $\tau_{0.1-0.8} = 0.45 \mu\text{s}$ was obtained. Voltage was ~ 300 kV, electric field was ~ 25 kV/cm. Resistance increased from $0.8 \cdot 10^{-3} \text{ Ohm}$ to 0.2 Ohm.
2. At the break of the primary circuit of ~ 1 MJ energy the voltage pulse of 1.2 MV with the front 0.3 μs was obtained [15]. The switch electric field was ~ 100 kV/cm.
3. Paper [16] gives the results of switch testing at the primary circuit energy of (1 – 10) MJ. At 10 MA current break the voltage pulse of 10^6 V with the rise front of 0.5 μs was observed. Switch power was $5 \cdot 10^{12} \text{ W}$. Resistance increased by a factor of 240, current derivative reached 10^{13} A/s . The

switch was tested in the mode with linear current density $\sim 0.2 \text{ MA/cm}$ at coaxial geometry (see Fig. 4). Switch resistance increased up to $1 - 2 \text{ Ohm/m}$. Within a wide range of parameters in energy, $(0.1 - 10) \text{ MJ}$, in current, $(1 - 15) \text{ MA}$, in time of current rise in the primary circuit, $(20 - 200) \mu\text{s}$, and in inductance, $(20-100) \text{ nH}$, a linear dependence of the considered switch time of operation on density of energy flux (per unity of switch area) flowing through the switch was obtained. It was also found that a noticeable part ($\sim 30\%$ at current density of 0.1 MA/cm) of released joule heat at the switch is dissipated in the form of visible radiation [16].

2. ELECTRO - EXPLODED FOIL FUSE OPENING SWITCH (FOS)

This section considers an electro - exploded type opening switch rated at $\sim 10^{13} \text{ W}$ power. The switch under consideration is designed for operation in the disk explosive magnetic generator (DEMG) circuit. The scheme of the studied version of the FOS design is shown in FIG. 5. The principal results of the switch studies are published in papers [6, 7, 8].

The FOS is an electrically exploded copper foil ($0.1 - 0.2 \text{ mm}$ in thickness) designed in the form of a thin - wall cylinder, so that in the whole the DEMG + FOS design is, in principle, axially - symmetric, like DEMG. Foil is located between thin insulators in the DEMG transmission line (see Fig. 5). The foil length can vary, but, as a rule, it is about equal to the DEMG length. The selected variant of foil location is beneficial in terms of switch self - inductance minimization. The DEMG with FOS differs from the DEMG without an opening switch in small enlargement of the transmission line gap. The outside diameter of the DEMG can be left unchanged.

Current from the DEMG initially flows along foil shunting the inductive load with its low resistance. In the process of current rise foil under action of magnetic forces comes into motion towards the outer current conductor of the transmission line compacting insulator and seeking for air gaps between foil, insulator and outer current conductor. To avoid foil thinning and

mechanical break at the junction with inner current conductor, the FOS design provides for gradual increase in foil mass at approaching the contact point (as is schematically shown in Fig. 5) and, respectively, gradual decrease in radial displacement of foil. The aim is to get rid of the danger of foil break, as it has been mentioned above, and to reduce longitudinal (along the system axis) pressure gradient in insulator between foil and outer current conductor. To the left of the contact point under consideration (see Fig. 5) this insulator is compressed by foil action and to the right of the contact point there is no compressing force. Therefore, if no above measures are taken, pressure in insulator near the foil contact point will have a jump and there will be a danger of foil break, as well as insulator damage.

The fact that the DEMG - FOS system design is practically axially - symmetric allows to calculate operation of such a design using 2D gas - dynamical computations of the DEMG and 1D MHD computations of the FOS. The existing experience of FOS designing, computations and experiments shows that such computations can be used to achieve good agreement between computations and experiments and to computationally optimize selection of principal initial parameters of experimental devices for particular experiment objectives (see, for example, [26]). Techniques of DEMG and FOS numerical simulation developed at VNIIEF are described in papers [20] and [21].

Specific examples of the use of the DEMG - FOS system with inductive and liner loads are described in papers [6, 7, 8]. Papers [7, 8] describe a most successful liner experiment with the 15 - module DEMG - FOS system where DEMG current of ~ 60 MA at DEMG and FOS diameter of ~ 400 mm (linear current density of 0.5 MA/cm) was commutated. In a quasi - constant inductive load of ~ 10 nH current pulse of ~ 35 MA with rise time (from the level 0.1 to the level 0.9 from the maximum) $\tau = 1.1$ μ s. From the DEMG through foil energy ~ 10 MJ at power ~ 10 TW and maximal voltage across foil of ~ 400 kV was therewith transferred.

Note that in the load circuit of the FOS systems an opening switch is useful and usually used which connects the load to the

FOS at a preset time or by a preset voltage value (see Fig. 5). Closure of this switch at the beginning of foil electric explosion allows, as with other opening switch types, to avoid undesirable current pre-pulse in the load. If the time of opening switch actuation is offset to a later side relative to the FOS then (in contrast to the exploded switches considered in paragraphs 1.1, 1.2), as computations show, it can lead to higher voltage across the FOS and higher speed of FOS operation. A detailed computational analysis of the effect of the time of load connection to the DEMG-FOS system can be found, for example, in paper [26].

3. MOVING CONDENSED LINER AS AN OPENING SWITCH.

This section considers the possibility of rapid transfer of magnetic energy obtained in the DEMG using an opening switch actuated by the magnetic field itself. The basic element of such a switch is a cylindric metal liner accelerated by magnetic field up to 8-10 km/s velocity and flying past a cylindric slot (a transmission channel) through which magnetic energy is transferred from EMG accumulative inductance to the load. The concept of such a switch was stated in paper [22]. Also note conceptually close paper [23] which theoretically considered the idea of magnetic "wicket". The objective of results of the research [9] stated here which was performed in 1981 at VNIIEF was to approach such mode of operation of the switch under consideration where the rate of energy transfer would be limited with the rate of transmission channel opening (liner velocity) and sluggishness of gas (plasma) entrained by the flowing magnetic field. It would be the case in the ideal mode of operation of the switch which can be outlined as follows. A liner opens a slot growing linearly with time. Through this slot the magnetic field flows from the region above the liner to a load. Residual air or gas contained in the accumulative inductance, if it is ionized and has sufficiently high conductivity, also flows together with the magnetic field. Speed of the flow, as in any contracting-expanding nozzle, is limited with the size of the narrowest bottleneck, that is the width of the slot, and the magnetic-

sound speed. On this basis one can obtain an estimate of the characteristic time τ of magnetic flux flow

$$\tau \sim \left(\frac{\Delta\Phi}{V} \right)^{1/2} \cdot \frac{\rho^{1/4}}{H}$$

Here $\Delta\Phi$ – the magnitude of the flowing magnetic flux;

V – liner velocity at the time of slot opening;

ρ – density of flowing plasma;

H – magnitude of the flowing magnetic field.

However, in the experiment such a mode was not realized.

The scheme of the design with the liner opening switch tested in the experiment is shown in Fig. 6. Aluminium liner 1 5 cm in length, 0.7 mm in initial thickness and ~ 14.5 cm in radius is accelerated by the magnetic field between copper side walls 2, 3 which are conductors carrying current to the liner. As soon as the liner has traversed a path of ~ 2.5 cm, its end facing the coaxial inductive load 4 slides off the current carrying wall and flies farther opening channel 5 for the magnetic flux accumulated in the buffer inductance 6 above the liner to flow to the load. To avoid movement of the near-wall portion of the liner at its sliding off the wall, cutoff 7 was put.

In order to select the liner parameters and compare with the experiment, computations of the disk EMG, 1 D MHD – computations of liner acceleration, as well as a number of 2 D MHD – computations (with account of strength and plasticity) of liner motion in the near-wall region were performed. Reasoning from the principal objective of the experiment the liner velocity was selected as high as possible but not reaching liner evaporation and the pressure in the buffer inductance and the load was reduced down to 20 – 25 mm Hg.

The principal results of the experiments are published in [9]. In the experiment the value of current through the liner reached 69 MA. The maximum value of the current derivative was $1.9 \cdot 10^{13}$ A/s. The time of current rise from the level 0.1 to the level 0.9 from maximal current equaled to ~ 9 μ s. It was impossible to measure actual liner velocity rather accurately due to the near-wall effects. Apparently, it is close to the computed

(8 - 10 km/s). The picture observed in the experiment with account of the obtained computed results in the acceleration chamber occurred at the time of electric explosion of the near-wall liner regions. At liner sliding off the current-carrying wall in the region of the entrance to the transfer channel quite a dense plasma formation (crosspiece) intensely emitting light formed. The plasma crosspiece was pressed by the magnetic field in the transfer channel and moved through it to the load. The speed of magnetic field lines of force was limited with the velocity of the plasma crosspiece which closed the current circuit. According to estimations, the velocity of the plasma crosspiece in the channel was 2 - 3 cm/ μ s, the time of its movement through the channel \sim 3 μ s and mass 2 - 5 g. The value of current switched to the load was \sim 29 MA. The characteristic time of energy load filling depended on the mean velocity of current crosspiece movement in the load and was \sim 1 μ s.

As the experiment showed, the switch actuated by the magnetic field at a liner current of 69 MA and a characteristic rise time of \sim 9 μ s allowed to transfer more than or about 2 MJ of energy to the load with \sim 5 nH inductance at the characteristic time of \sim 1 μ s.

Note that moving foil as an opening switch was also considered in paper [24]. The experiments described in this paper were performed in the same manner as ours, with non-evaporating foil, with high linear current density \sim 0.4 MA/cm, but total current and cylindrical radius of foil were considerably less (\sim 2 MA and 0.8 cm, respectively). The time of switch operation turned out to be \sim 1 μ s.

4. COMPARISON AND DISCUSSION OF VARIOUS OPENING SWITCH TYPES.

Principal parameters of the above switch types reached in the experiments are summarized in Table below.

Table.

Switch type	I MA	E MJ	D cm	J MA/ cm	U MV	τ μ S	ΔE MJ	W TW
Exploded with ribbed barrier	1		5	0.06		0.5		
	2.8		8	0.11		1		
	8.5		16	0.17		1.5		
	85	~ 10	~ 100	0.17		1.7		
Cumulative	25	~ 10	20	0.4	~ 2	2 - 2.5	~ 2	~ 1
Exploded with arc quenching	7.3				0.3	0.45		
	10			0.2	1	0.5	2.5	~ 5
		~ 1			1.2	0.3		
electro - exploded foil	60		40	0.48	0.4	~ 1	~ 10	~ 10
Liner	~ 2		1.6	~ 0.4		~ 1		
	69		24	0.9		~ 1	> 2	> 2
Plasma Flow Switch	12	~ 5	15.2	0.25	0.5	0.25		~ 5

Table notations:

I - broken current;

E - energy in the primary circuit;

D - switch diameter;

J - linear density of broken current;

U - maximal voltage across the switch;

τ - time of switch operation;

ΔE - energy transferred to the load;

W - switch power.

For comparison the last table row gives Plasma Flow Switch (PFS) parameters recently reached at Phillips Laboratory (PL) [11].

A question arises what parameters characterize switch operation most adequately and what the parameters are they have to be compared by. Of course, there is no unambiguous and universal answer to these questions since quality of each switch eventually depends on a particular problem which it has been developed for. Nevertheless, try to state some general considerations regarding it. Assume that gravity of the conditions a switch is operating under can be mainly characterized with three parameters: the value of linear density of broken current at the time of opening, the time of its rise, and the value of voltage. The higher each of these values is, the harder it is to make a switch of a preset opening time. The parameters characterizing the experiment scale (total current, total energy, device diameter) will be considered by us as those of inferior priority. It can be justified to some extent with the module principle according to which a commutator for total current as high as is wished can be built up of rather high number of small commutators (modules). Speed of operation of the large commutator can therewith be the same as that of a single module if the conditions of operation for each module are preserved and strict synchronism of operation for all the modules is secured.

Transfer to Table review. From Table it is seen that a record - holder in speed of operation is the PFS ($\tau \cong 0.25 \mu s$). A record - holder in voltage amplitude is the arc quenching switch ($U \sim 1.2 MV$). Both the record - holders operated under the conditions of linear current density of $\sim 0.25 MA/cm$. A record - holder in current density is the liner switch ($\sim 0.9 MA/cm$). About twice as low but rather high current density is characteristic of the electro - exploded foil switch and the cumulative switch ($0.48 MA/cm$ and $0.4 MA/cm$, respectively).

Attaching the "scale" parameters to the comparison, we find that a record - holder in energy transferred to the load and in switch power is the electro - exploded foil switch ($\sim 10 MJ$ and $\sim 10 TW$, respectively) and a record - holder in total current is the exploded switch with a ribbed barrier ($85 MA$).

Each of the above switches has its own principle of operation which was mentioned in the previous sections. However, we would like to pay attention to one property by which all the switch types can be subdivided into two large classes. All the switches, except liner ones, allow magnetic flux to pass through themselves and leave joule heat inside themselves. This is one class of switches. Among the above switches it includes the exploded switches with a ribbed barrier, the cumulative switches, the arc quenching switches, and the electro - exploded switches. The second class of switches includes the liner switches with a condensed liner, the magnetic "wicket" type switches, and the Plasma Flow Switch. In these switches magnetic flux flows to the load at mechanical opening of the channel for the flow. An essential feature of this switch class is the fact that for them energy of magnetic field expansion does not remain in a switch but flows to the load together with the magnetic flux in the form of kinetic, as well as thermal energy of plasma. A plasma source is liner or magnetic "wicket" material and residual gas in the space where the flowing magnetic flux is accumulated. The time of operation of such switches must be the less, the higher the rate of channel opening (liner velocity) and the less the flowing plasma density.

There is a note concerning the effect of commutated current rise time on switch operation. For all the switches, except the arc quenching switch, increase in the above time leads to increase in switch mass and, eventually, to increase in the time of switch operation. An exception to this rule, apparently, is the arc quenching switch. As it has been mentioned above in Section 1.3, paper [16] obtained quite an unexpected result for this switch: within a wide parameter range, including at the primary circuit current rise times of $20 - 200 \mu s$, the time of switch operation appeared to be dependent (linearly) only on a single parameter: on density of energy flux (per switch area unity) passing through

a switch. Here the surprising thing is dependence on a single parameter only.

One more note pertains to the effect of a load type on energetic efficiency of switch operation. Recently one of most frequently used load types in opening switch experiments has been the liner type. Its essential difference from other loads is inductance increasing with time. As computations show, under appropriate conditions this difference allows to transfer essentially greater part of energy to the liner from the primary circuit than it is possible at constant inductances of the primary and secondary circuits. For example, in the electro - exploded foil opening switch experiments it appeared to be possible to increase the above part up to 0.6 - 0.7 (recall that in the case of constant and equal inductances the maximum energy transfer factor is $1/4$). To attain that effect, three conditions must be satisfied. First, the time of switch opening must be much less than the time of liner implosion. Second, at the time switch opening load inductance must be much less than the primary circuit inductance. Third, active resistance (impedance) must be much higher than the characteristic impedance of the imploding liner. In other words, in the open state a switch must be fairly "transparent" for magnetic flux and must weakly shunt the load. Moreover, of course, it is assumed that the ratio of primary circuit and load inductances in principle is adjusted to obtain a high transfer factor, i. e. at the time of liner implosion load inductance is much more than the primary circuit inductance. If under these conditions the strength of the inequalities is reduced from "much higher" to "of the order of" then the effect will monotonely reduce. If the primary circuit inductance is not constant, as it is the case with EMG systems, then this fact additionally promotes liner energy increase.

To conclude with, state some considerations regarding future potential of highest - speed opening switches. As it has been mentioned above, the plasma flow switch operates at the highest speed within the class of switches under consideration. This switch can have certain advantages as compared to the condensed liner switch. Imposing the condition of liner condensing, we expected that liner material would not interfere with magnetic flux flow. However, the experience showed that it is not the case. Rather a massive plasma crosspiece is formed

from liner material and it is it that restricts switch speed operation. In such a case it is more beneficial to go immediately to the plasma liner, with lower mass and higher velocity. It was just made in the Plasma Flow Switch. The plasma liner is free of velocity limitation associated with the condensing condition. Therefore, in principle, further decrease in liner mass and increase in liner velocity is a way for further speeding up of laser operation. However, there is a difficulty: the higher velocity of the liner is, the greater the path is it travels during the time of primary circuit current rise and the higher inductance introduced by it is. For this reason, we believe, it is not occasional that the PFS switch was developed and applied on facilities with rather short time of primary circuit current rise ($\sim 3 \mu s$). It is harder to use this switch for the EMG and other lower - speed facilities, though two - stage switches with successive current pulse sharpening, like, for example, in paper [27], are possible. One more difficulty on the way of velocity enhancement for the plasma liner, as a switch, is development of instabilities at large liner displacement. However, this difficulty can be overcome by using a compact toroid (CT) as an opening switch [28], since a feature of CT is its enhanced stability at rather large displacement paths. Hence, on the whole the direction of works to investigate Plasma Flow Switches and compact toroids seems to us as being of significant future potential. Further essential results can be expected in this direction in the near future.

REFERENCES.

1. Chernyshev V. K., Volkov G. I., Vakhrushev V. V. Study of Basic Regularities of Multi-MA-Current Pulses With Short Risetime by EMG Circuit Interruption //Megagauss Physics and Technology /Ed. by P. J. Turchi. N. Y.: L.: Plenum Press, 1980. P. 663.
2. Kotov Ju. A., Tsyplenko A. P. Studying an explosive opening switch cumulative dielectric jets. //Superstrong magnetic fields. Physics. Technology. Application. /Ed. by V. M. Titov, G. A. Shevtsov. Moscow, Nauka Publishers, 1984. p. 402.
3. Pavlovsky A. I., Vasyukov V. A., Russkov A. S. Formation of fast - rising megaampere current pulses from magnetocumulative generators. - Pis'ma v ZHTF, 1977, v. 3 No. 16, p. 789.
4. Zubkov P. I., Lukyanchikov L. A., Ten K. A. - PMTF, 1981, No 5, p. 128.
5. V. A. Burtsev, N. V. Kalinin, A. V. Luchinsky. Electric explosion of conductors and its use in electromechanical facilities. Moscow. Energoatomizdat Publishers, 1990.
6. A. A. Petrukhin, V. V. Golubev, V. M. Danov, V. I. Mamyshev, E. S. Pavlovsky, A. A. Prokopov, M. S. Protasov, A. K. Chernyshev, V. A. Shevtsov, V. B. Yakubov. Results of experiments on megajoule range energy transfer from an explosive magnetic generator using a foil opening switch. //Superstrong magnetic fields. Physics. Technology. Application. /Ed. by V. M. Titov, G. A. Shevtsov. Moscow, Nauka Publishers, 1984. p. 384.
7. V. K. Chernyshev, A. M. Buyko, V. N. Kostukov, A. I. Kuzyayev, A. A. Kulagin, V. I. Mamyshev, A. B. Mezhevov, A. I. Nechaev, A. A. Petrukhin, M. S. Protasov, V. I. Shevtsov, and V. B. Yakubov. Investigation of Electrically Exploded Large Area Foil for Current Switching. //Megagauss Field and Pulsed Power Systems/ Ed. by V. M. Titov and G. A. Shvetsov. N. Y.: L.: Nova Science Publishers, 1990. P. 465.
8. A. K. Chernyshev, M. S. Protasov, V. I. Shevtsov, P. N. Piskarev, E. I. Zharinov, G. I. Volkov, V. V. Vakhrushev, V. A. Ivanov, V. A. Demidov, S. V. Pak, N. P. Bidylo, B. E. Grinevich, V. P. Pogorelov, A. A. Petrukhin, A. I. Kuzyayev, V. B. Yakubov, V. I. Shpagin. Explosive - magnetic generators

- of "Potok" family. //VANT. Ser. Mat. Modelir. Fiz. Protsessov. 1992. No 4. p. 33-41.
9. A. A. Petrukhin, N. P. Bidylo, S. F. Garanin, V. M. Danov, V. V. Zmushko, A. I. Kuzyayev, V. N. Mokhov, E. S. Pavlovsky, A. A. Prokopov, M. S. Protasov, V. K. Chernyshev, V. A. Shevtsov, V. B. Yakubov. "Current pulse generation using an opening switch actuated by magnetic field." //Superstrong magnetic fields. Physics. Technology. Application. /Ed. by V. M. Titov, G. A. Shvetsov. Moscow, Nauka Publishers, 1984. p. 406.
 10. J. H. Degnan, W. L. Baker, K. E. Hackett, D. J. Hall, J. L. Holmes, J. B. Kriebel, D. W. Price, R. E. Reinovsky, J. D. Graham, E. A. Lopez, M. L. Alme, G. Bird, C. N. Boyer, S. K. Coffey, D. Conte, J. F. Davis, S. W. Seiler, and P. J. Turchi, IEEE Trans. Plasma Sci. PS - 15, 760, 1987.
 11. P. J. Turchi, J. F. Davis, M. L. Alme, G. Bird, C. N. Boyer, S. K. Coffey, D. Conte, S. W. Seiler, W. L. Baker, J. H. Degnan, D. J. Hall, J. L. Holmes, W. F. McCullough, D. W. Price, M. H. Frese, R. E. Peterkin, N. F. Roderick, J. D. Graham and E. A. Lopez. Generation of High - Energy x - Radiation Using a Plasma Flow Switch. J. Appl. Phys. 69 (4), 15 February 1991.
 12. Chernyshev V. K., Andreevskikh L. A., Volkov G. I. et al. Mechanical Conductor Disruption Character in Explosive Current Commutators. //Megagauss Field and Pulsed Power Systems/ Ed. by V. M. Titov and G. A. Shvetsov. N. Y.: L.: Nova Science Publishers, 1990. P. 533.
 13. V. K. Chernyshev, V. V. Vakhrushev, G. I. Volkov, V. A. Ivanov, and O. D. Mikhailov. Time Dependence of Switching Delay upon the Brouken Foil Thickness //Megagauss Field and Pulsed Power Systems/ Ed. by V. M. Titov and G. A. Shvetsov. N. Y.: L.: Nova Science Publishers, 1990. P. 481.
 14. Conte D., Ford R. D., Lupton W. A., Vitkovitsky I. M. Proceedings of 7th Symposium Engineering Problems of Fusion Research. Knoxville, Tennessee, 1977. Vol. 2, № 4. P. 1066-1070.
 15. A. I. Pavlovsky, V. A. Vasyukov, N. F. Popkov, A. S. Russkov, A. S. Pikar', V. I. Kargin, E. A. Ryaslov, G. F. Makartsev. Research into high energy density accumulation and commutation. // Superstrong magnetic fields. Physics. Technology. Application. /Ed. by V. M. Titov, G. A. Shvetsov. Moscow, Nauka Publishers, 1984. p. 410.

16. A. I. Pavlovsky, N. F. Popkov, A. S. Pikar', E. A. Ryaslov, V. I. Kargin, and A. S. Russkov. MC - Generator Current Contour Break by Explosive - Driven Plasma Switch //Megagauss Field and Pulsed Power Systems/ Ed. by V. M. Titov and G. A. Shvetsov. N. Y.: L.: Nova Science Publishers, 1990. P. 503.
17. A. I. Pavlovsky, L. P. Babich, P. V. Mironychev, and I. T. Shmorin. Mechanism of a Resistance Leap in High-Explosive Driven Plasma Opening Switch. //Megagauss Field and Pulsed Power Systems/ Ed. by V. M. Titov and G. A. Shvetsov. N. Y.: L.: Nova Science Publishers, 1990. P. 509.
18. A. P. Yershov, P. I. Zubkov, Yu. N. Ilyanovich, L. A. Lukyanchikov, K. A. Ten, Yu. V. Ryabinin. Current break with arc shunting by conducting detonation products. // Superstrong magnetic fields. Physics. Technology. Application. /Ed. by V. M. Titov, G. A. Shvetsov. Moscow, Nauka Publishers, 1984. p. 397.
19. L. Baker. Theory and Scaling of Explosive Fast - Opening Switch. //Superstrong magnetic fields. Physics. Technology. Application. /Ed. by V. M. Titov, G. A. Shvetsov. Moscow, Nauka Publishers, 1984. p. 395.
20. A. M. Buyko, O. M. Burenkov, S. F. Garanin, Ch. H. Hakimova, V. M. Kol'chatov, V. I. Mamyshev, V. N. Mokhov, A. I. Panov, V. V. Rasskazova, P. V. Rybachenko, K. N. Sul'g, V. B. Yakubov, and V. V. Zmushko. Modeling of Ultrapowerful Current Generators and High - Temperature Plasmas. (Subcontract № 4755M0014 - 9Y).
21. A. M. Buyko, V. M. Danov, V. I. Mamyshev, V. B. Yakubov. A technique for numerical simulation of disk explosive - magnetic generators with electro - exploded current opening switch and liner load. (VANT. to be published).
22. Pavlovsky A. I., Lyudaev R. Z., Kravchenko A. S. et al.-In: Megagauss Physics and Technology /Ed. by P. J. Turchi. N. Y.: L.: Plenum Press, 1980. P. 595.
23. J. Brownell, R. Bowers, A. Greene, I Lindemuth, G. Nickel, T Oliphant, D. Weiss. System Requirements for the Los Alamos Foil Implosion Project. //Superstrong magnetic fields. Physics. Technology. Application. /Ed. by V. M. Titov, G. A. Shvetsov. Moscow, Nauka Publishers, 1984. P. 221.

24. D. R. Kania, E. L. Zimmermann, R. J. Trainor, L. R. Veese, and L. A. Jones. Experimental Tests of a Moving Foil as a High Current Vacuum Opening Switch. *Appl. Phys. Lett.* 45 (1), 1 July 1984.
25. J. H. Goforth and S. P. Marsh. Explosively Formed Fuse Opening Switches for Use in Flux-Compression Generator Circuits. // *Megagauss Field and Pulsed Power Systems*/ Ed. by V. M. Titov and G. A. Shvetsov. N. Y.: L: Nova Science Publishers, 1990. P. 515.
26. V. N. Mokhov, V. K. Chernyshev, A. M. Buyko, S. F. Garanin, V. A. Demidov, A. I. Kuzyayev, E. S. Pavlovsky, A. A. Petrukhin, V. B. Yakubov. "Setting up an experiment with 15-module disk EMG, electro - exploded current opening switch and liner load, 1 - st collaborative VNIIEF-LANL experiment. VNIIEF report, 1993.
27. J. H. Goforth, H. Oona, A. E. Greene, D. H. Herrera, D. L. Peterson, B. G. Anderson, W. E. Anderson, D. E. Bartram, J. H. Brownell, R. L. Bowers, R. E. Chrien, J. C. Cochrane, C. E. Findley, M. F. Fowler, O. F. Garcia, M. L. Godgdon, J. C. King, I. R. Lindemuth, C. M. Lund, S. P. Marsh, T. Oliphant, J. V. Parker, R. E. Reinovsky, N. F. Roderick, J. S. Shlachter, L. J. Tabaka, D. T. Torres, P. J. Turchi, L. R. Veese, B. J. Warthen, D. L. Weiss and F. J. Wysocki. Review of the Procyon Explosive Pulsed Power System. Ninth IEEE International Pulsed Power Conference. Albuquerque, New Mexico, 1993. Digest of technical papers. P. 36.
28. R. E. Peterkin, Jr., D. E. Bell, J. H. Degnan, M. R. Douglas, T. W. Hussey, B. W. Mullins, N. F. Roderick, and P. J. Turchi. A Long Conduction Time Compact Torus Plasma Opening Switch. XVth International Symposium on Discharges and Electrical Insulator in Vacuum - Darmstadt - 1992.

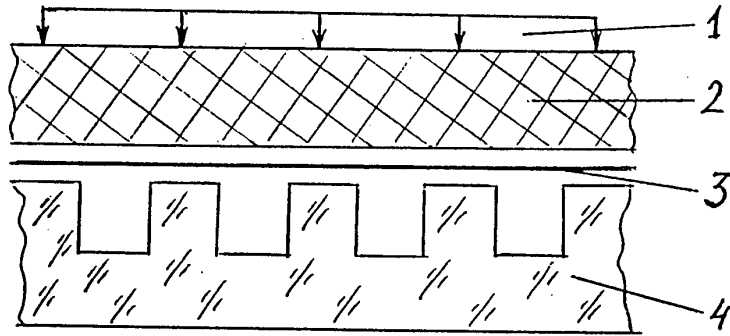

Fig. 1. Scheme of opening switch with break of current - carrying foil at its casting onto a ribbed barrier.

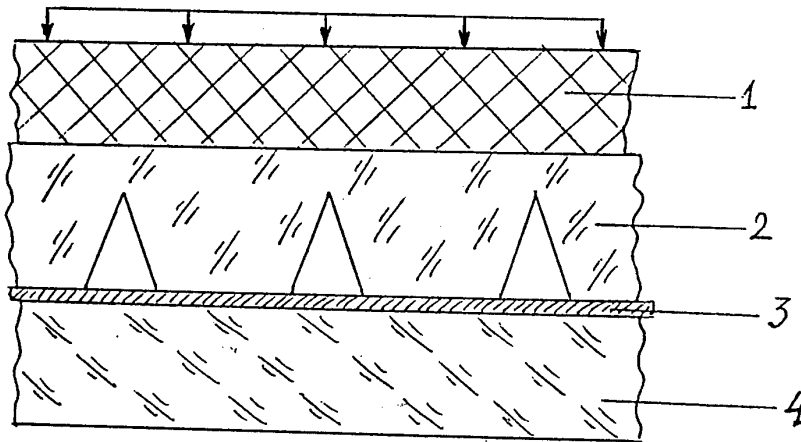

Fig. 2. Scheme of opening switch with break of current - carrying foil by dielectric cumulative jets.

- 1 - HE charge.
- 2 - Insulator with cumulative hollows.
- 3 - Foil.
- 4 - Insulator.

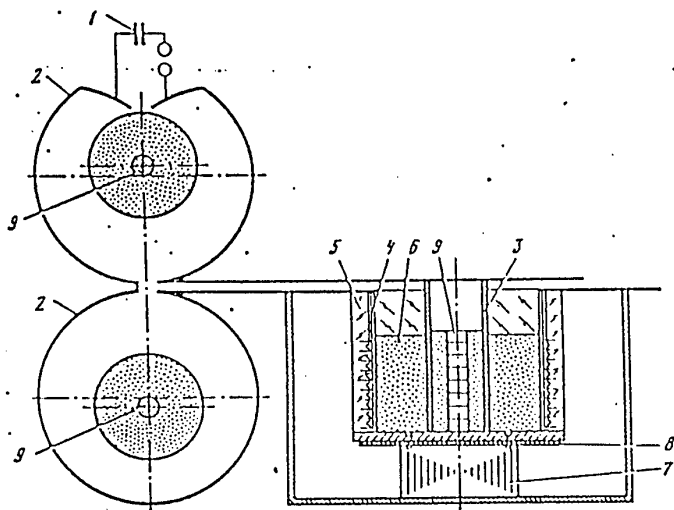

Fig. 3. Scheme of exploded plasma opening switch.

- 1 -- Capacitor bank.
- 2 -- MK -- generator.
- 3 -- Metal pipe.
- 4 -- Cylindric plasma channel.
- 5 -- Dielectric barrier.
- 6 -- HE charge.
- 7 -- Load.
- 8 -- Polyethylene insulation.
- 9 -- HE charge initiation system.

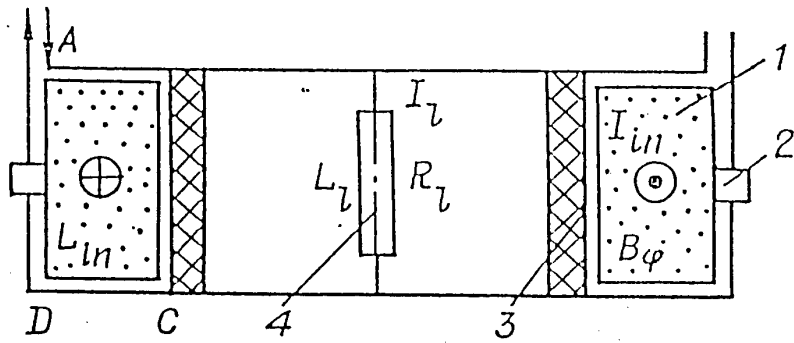

Fig. 4. Scheme of exploded plasma opening switch.

1 - HE charge.

2 - HE charge initiation system.

3 - Insulator.

4 - Load.

L_{in} - Inductive accumulator.

I_{in} - Inductive accumulator current.

I_l, L_l, R_l - Current, inductance and resistance of load, respectively.

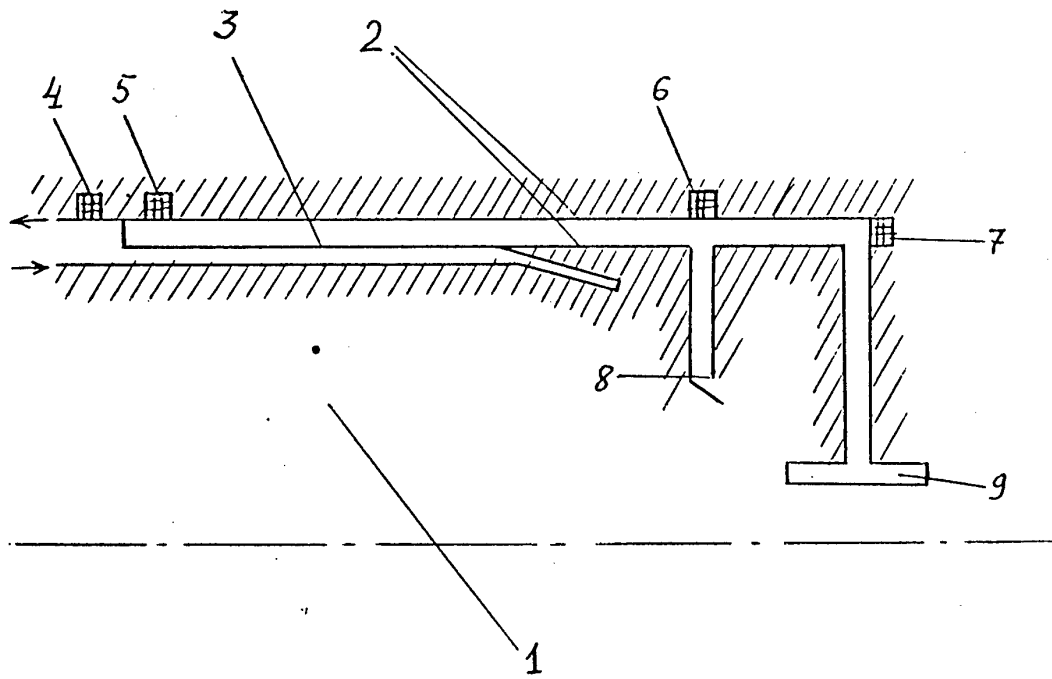

Fig. 5. Scheme of device with electrically exploding foil.

- 1 - Disk EMG.
- 2 - Transmission line.
- 3 - Foil.
- 4, 5, 6, 7 - Inductive probes.
- 8 - Closing switch.
- 9 - Load.

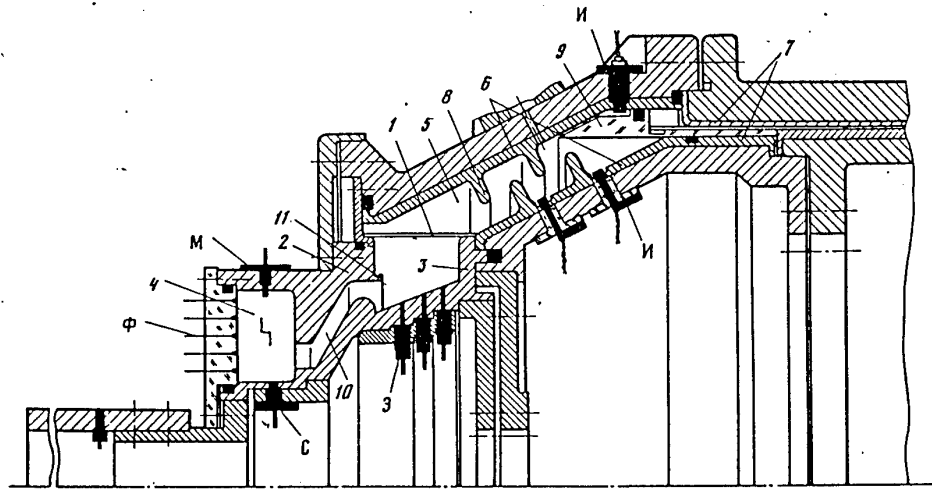

Fig. 6. Scheme of device with liner opening switch.

- 1 - Liner.
- 2, 3 - Side walls.
- 4 - Load.
- 5 - Accumulative inductance.
- 6 - Current carrying walls.