

125032

JPRS-EER-86-026

26 February 1986

# East Europe Report

**DISTRIBUTION STATEMENT A**

Approved for public release;  
Distribution Unlimited

**DTIC QUALITY INSPECTED 2**

19980305 115

**FBIS**

**FOREIGN BROADCAST INFORMATION SERVICE**

REPRODUCED BY  
NATIONAL TECHNICAL  
INFORMATION SERVICE  
U.S. DEPARTMENT OF COMMERCE  
SPRINGFIELD, VA. 22161

29  
216  
A10

#### NOTE

JPRS publications contain information primarily from foreign newspapers, periodicals and books, but also from news agency transmissions and broadcasts. Materials from foreign-language sources are translated; those from English-language sources are transcribed or reprinted, with the original phrasing and other characteristics retained.

Headlines, editorial reports, and material enclosed in brackets [ ] are supplied by JPRS. Processing indicators such as [Text] or [Excerpt] in the first line of each item, or following the last line of a brief, indicate how the original information was processed. Where no processing indicator is given, the information was summarized or extracted.

Unfamiliar names rendered phonetically or transliterated are enclosed in parentheses. Words or names preceded by a question mark and enclosed in parentheses were not clear in the original but have been supplied as appropriate in context. Other unattributed parenthetical notes within the body of an item originate with the source. Times within items are as given by source.

The contents of this publication in no way represent the policies, views or attitudes of the U.S. Government.

#### PROCUREMENT OF PUBLICATIONS

JPRS publications may be ordered from the National Technical Information Service, Springfield, Virginia 22161. In ordering, it is recommended that the JPRS number, title, date and author, if applicable, of publication be cited.

Current JPRS publications are announced in Government Reports Announcements issued semi-monthly by the National Technical Information Service, and are listed in the Monthly Catalog of U.S. Government Publications issued by the Superintendent of Documents, U.S. Government Printing Office, Washington, D.C. 20402.

Correspondence pertaining to matters other than procurement may be addressed to Joint Publications Research Service, 1000 North Glebe Road, Arlington, Virginia 22201.

26 February 1986

## EAST EUROPE REPORT

### CONTENTS

#### AGRICULTURE

##### HUNGARY

- Paprika Cultivation Dwindling Dangerously  
(Istvan Pekar; MAGYAR MEZAGAZDASAG, No 43, 23 Oct 85) ... 1

##### POLAND

- Some Young People Are Returning to Agriculture  
(Wladyslaw Bielski; WALKA MLODYCH, No 50, 15 Dec 85) .... 6
- Latest Statistics on Crop Yields, Livestock Numbers  
(GROMADA-ROLNIK POLSKI, 19 Nov 85) ..... 10

#### ECONOMY

##### BULGARIA

- Economic Crimes, Administrative Incompetence Exposed  
(TRUD, 17 Oct 85) ..... 12
- Public Claim for the 103 Million Leva, Editorial 12  
Success of Gabrovo Bailiffs, by Ivanka Koseva 13  
The Readers Reply 16  
A Miner's Reply, by Stoyan Buchvarov 16  
Reorganization of Bailiff's Office, by Ivan Lalev 18  
Correction 19

##### GERMAN DEMOCRATIC REPUBLIC

- Tasking Manual To Coordinate Research, Development in Combines  
(Karl-Heinz Bernhardt; CHEMISCHE TECHNIK, No 5, May 85) 20

Chemical Industry Specifies Criteria for Recycling Products (Eberhard Garbe; CHEMISCHE TECHNIK, No 5, May 85) .....	27
Forestry Enterprises Establish New Settlement Prices (E. Uhlig; SOZIALISTISCHE FORSTWIRTSCHAFT, No 9, Sep 85)	37
Forestry Industry Designs Financial Plans for 1986-1990 (Habil W. Binder, et al.; SOZIALISTISCHE FORSTWIRTSCHAFT, No 9, Sep 85) .....	44
Innovations in Brown Coal Mining Assessed (PRESSE-INFORMATIONEN, No 138, 28 Nov 85) .....	48

## MILITARY

### INTERNATIONAL AFFAIRS

Warsaw Pact Navies Using Tarantul-I Patrol Boat (Siegfried Breyer; SOLDAT UND TECHNIK, No 11, Nov 85) ....	51
---	----

### BULGARIA

Revolutionary Vigilance, Preservation of Military Secrets Urged (Stoyan Kunchev; NARODNA ARMIYA, 14 Nov 85) .....	58
Editorial Calls for Stricter Discipline (NARODNA ARMIYA, 19 Nov 85) .....	60

### GERMAN DEMOCRATIC REPUBLIC

New Navy Torpedo Boats Described (H. Mehl; VOLKSARMEE, No 39, 1985) .....	62
Ship-Mounted Antiaircraft Weapons Described (Ulrich Fink; AR-ARMEERUNDSCHAU, No 11, Nov 85) .....	66
Developments in Flight Navigation Systems Discussed (G. Lehmann; MILITAERTECHNIK, No 5, 1985) .....	70

### POLAND

Utilization of Air Defense Rocket Forces Within Defense System (Tadeusz Kropiowski; PRZEGLAD WOJSK LOTNICZYCH I WOJSK OBRONY POWIETRZNEJ KRAJU, No 12, Dec 85) .....	76
Attitudes Toward Military Service Surveyed (WOJSKO LUDOWE, No 10, Oct 85) .....	79
Positive Attitudes, by Jerzy Wisniewski	79
Negative Attitudes, by Bogdan Sambor	82

POLITICS

ALBANIA

Mediocrity in Education, Production, Science Deplored (ZERI I POPULLIT, 23 Nov 85) .....	89
---	----

HUNGARY

PPF Debating 'Direct' Democracy, Popular Referendum (Istvan Kukorelli Interview; ELET ES IRODALOM, 13 Dec 86)	92
--	----

POLAND

Election, Post-Election Notes (Various sources, various dates) .....	97
Commission, Convention Differences Outlined, by Robert Jordan	97
Selected Voter Descriptions	98
Ninth Sejm Term Begins	100
ZSL, SD Election Participation Evaluated	101
Commission Work on Internal Affairs Described, Zygmunt Surowiec Interview	102
Pre-Election Activities (Various sources, various dates) .....	106
National Electoral Commission Inspection, Jerzy Breitkopf Interview	106
SD CC, PRON Meet on Elections	108
Veterans Appeal for Election Participation	109
Police Fight Social Ills, Says Kiszczak	109
Election Lists Checked by Voters	110
Extension of Election List Check	111
OPZZ Committee on Pre-Election Meetings	111
OPZZ Comments on Union Candidates, by Teresa Grabczynska	112
Journalists' Sociopolitical Duties Discussed	113
Too Few Lawyers as Candidates	115
Journalist-Candidate on Campaign, Duties, Ryszard Lukasiewicz Interview	115
Plato's Vision of Authority Figures Favored, by Wieslaw Wyrzykowski	116
Proposed Changes in Central Administration (TRYBUNA LUDU, 8 Nov 85) .....	117
New Sejm Committees Drawn Up (TRYBUNA LUDU, 11 Nov 85) .....	120

Provincial Delegate Meetings in Sejm (RZECZPOSPOLITA, 11 Nov 85) .....	121
New Censorship Procedures in States of Emergency (MONITOR POLSKI, No 17, 17 Jul 85) .....	122
Press, Journalists Featured (ZYCIE WARSZAWY, 14 Nov 85; TRYBUNA LUDU, 15, 20 Nov 85)	125
New TRYBUNA LUDU Editor Named	125
New Journal	125
Information Access, Press Law Discussed	126
Bloc Journalists on Peace, Defense Role	126
Labor, Union Issues Featured (TRYBUNA LUDU, various dates; RZECZPOSPOLITA, 20 Nov 85)	128
OPTZ Hosts International Energy Unionists	128
Quality of Party Worker Discussed, by Teresa Grabczynska	128
Labor Code Amendment Spurs Debate	131
Miner Unions Inaugural Council Session	132
Teachers Union Seminar	133
New Book Profiles Leading Political Personalities (Zbyslaw Rykowski, Wieslaw Wladyka; POLITYKA, 21 Sep 85)	134

#### SCIENCE AND TECHNOLOGY

##### BULGARIA

Specifications of 'ES 1055 M' Computer (TEKHNICHESKO DELO, 28 Sep 85) .....	146
'Balkankar' Line of Products Described (Lyubomir Stoimenov; TEKHNICHESKO DELO, 28 Sep 85) .....	147
'Bolshevik' Plant Advertizes Its Products (TEKHNICHESKO DELO, 28 Sep 85) .....	151

##### CZECHOSLOVAKIA

Importance of Biotechnology Emphasized (RUDE PRAVO, 28 Dec 85) .....	153
---	-----

##### GERMAN DEMOCRATIC REPUBLIC

Progress Seen in Refining of Metallurgical Raw Materials (NEUE HUETTE, No 9, Sep 85) .....	156
---	-----

Importance of Mercury, Precious Metals Reprocessing Stressed (NEUE HUETTE, No 9, Sep 85) .....	175
Mercury Demands Better Reprocessing, by Klaus Oppermann Electronics Scrap Yields Metals	175 181

POLAND

Procedures for Rail Shipment of Hazardous Materials Detailed (EKSPLOATACJA KOLEI, No 7, Jul 85) .....	185
--	-----

SOCIOLOGY

HUNGARY

Factors Affecting Labor Force Mobility (Marie Frey, Dezso Vass; NEPSZABADSAG, 29 Dec 85) .....	192
---	-----

POLAND

Warsaw Archdiocesan Priests, Bishops Convene (PRZEGLAD KATOLICKI, No 41, 13 Oct 85) .....	196
--	-----

Academy of Social Sciences Rector on Role of Intelligentsia (Marian Orzechowski Interview; ZYCIE WARSZAWY, 9 Oct 85)	199
---	-----

Editor on Necessity of Making Choices, Rejecting 'Myths' (Zdzislaw Morawski; ZYCIE WARSZAWY, 12-13 Oct 85) .....	202
---	-----

Latest Issue of 'ZNAK' Reviewed (Jerzy Kolataj; TYGODNIK POWSZECHNY, No 41, 13 Oct 85)	206
---	-----

Briefs

New Book on Wyszynski	209
Diocese Disowns Parish Priest's Article	209
In Defense of Religion	209

AGRICULTURE

HUNGARY

### PAPRIKA CULTIVATION DWINDLING DANGEROUSLY

Budapest MAGYAR MEZAGAZDASAG in Hungarian No 43, 23 Oct 85, p 10

[Article by Istvan Pekar: "Paprika-Show with Preoccupations"]

[Text] The most important spice of Hungarian cuisine is ground red paprika. But it is not only a celebrity of our cuisine, but also one of our most characteristic products on foreign markets. Yet over the last year we have already heard and read about problems related to the spice paprika, and at the end of last summer the situation turned to be really serious. The usual red paprika bags disappeared from the shelves of the groceries, fortunately not for a long time.

At the time of paprika harvest the experts have met at Kalocsa in order to analyze the current situation and to discuss the tasks of the immediate future.

Too much paprika is an economic problem, but if there is none it is already a political headache--said in his opening speech Janos Miskolczi, first secretary of the MSZMP city committee of Kalocsa.

As a result of not quite carefully planned developments, which had been initiated in 1976, by 1980-81 huge, unsaleable stocks of paprika had accumulated and set back production.

Paprika cultivation moved from the big farms to the household units, although production is still being integrated by the big enterprises. Because of its declining lucrativity a growing number of people have stopped producing paprika and started planting more lucrative spices and medicinal herbs. Expensive Western technological equipment lies now unexploited, and the sowing area of paprika continues to decline further.

#### Sowing Areas Should Be Increased

Following the opening speech, Attila Zsitvay, deputy head of section of the Ministry of Agriculture and Food Industry, discussed the timely questions of production. Our domestic need of spice paprika is about 6,500 tons, and our realistic export prospect is 7,000 to 8,000 tons. Thus we need a total of 13,000-15,000 tons of ground paprika, that can be processed from 85,000-95,000 tons of paprika pods. Taking into account the current yields, this amount can be produced on 9,000-10,000 hectares. Yet this year the sowing area was only 7,300 hectares (once its size had already reached 13,000 hectares).

The yearly yield is extremely unsteady. In one year it is 12 tons per hectare and in another only 5 tons. The fluctuation in output is characteristic of paprika growing, we shall have to take this into account in the future.

The decrease in the sowing area is due to the lack of interest, and interest depends on the state purchase price of paprika. The processing industry can increase the purchasing by raising the consumer price of ground paprika, further by using the income from export or eventually by decreasing the turnover tax on paprika.

The export price is hardly more than the production cost of paprika. The export price of ground paprika, calculated on crude paprika pods was, over the last five years, around 7-8 forints. This means that the profit generated by export does not make it possible to increase the production price. The turnover tax has lately been reduced from 27 percent to 11 percent. This may provide a coverage for an increase in the state purchasing price, but if this does not turn out to be enough, raising the domestic consumer price remains the only remedy.

If we want to keep our export market, we cannot disregard development. Research should focus more on concrete goals than it does right now, it should provide help for the fulfillment of current marketing requirements. We should pay attention to the mechanization of harvesting since manpower is ever more scarce.

#### We Need Manually Harvestable Species

Dr Karoly Kapellar, director of the Spice Paprika Research Center of the Vegetable Research Institute reported on the new results of spice paprika research. The yield of our species is around 20-22 tons. From the spicy species breeds we may mention the V-2, V-3 and the 178 from Szeged, while among the less spicy ones the K-501, K-702 and the No 1 of Szeged are worth mentioning.

It is very important that the new species should be resistant to diseases. This year we have also experienced a decline in production, yields were down 1.5-2 tons. For a safe harvest we should experiment with 3-4 species on each farm.

Over the last couple of years the seed supply worked with fits and starts, and the farms sowed commercial seeds for reasons of economy, although progress cannot be expected in this way.

Research should serve practice, in other words it should deliver the kinds of species that agree with the technology employed. Today this is not the case. In Hungary paprika is harvested only manually, while we are planting paprika species that have upright pods, suitable for machine harvesting. This fact significantly reduces the performance of the pickers. While a skilled picker can harvest daily 300-400 kilograms from the paprika species with hanging pods, he can only gather 200 kilograms from the upright pod species.

Aside from the hybridization of manually easily harvestable species, our researchers also take into consideration the reappearance of harvesting machines. We need the kind of hybrids, 90-95 percent of which are ripening at the same time.

## Lack of Desire to Produce

The economic situation of the spice paprika was analyzed by Dr Lajos Lakatos, director of the Agro-Industrial Association of the Kalocsa area. Despite recent developments, the economic lucrativity of paprika even in recent years has been attributed to above average profitability within the food processing industry. The dollar earning index of the Paprika and Preserve Factory was 19 percent higher than the food processing industry average. Even in 1984, when our paprika harvest was mediocre, producers paid 75 million forints as turnover tax to the state treasury. Thus the spice paprika is a useful product of our national economy.

However those working in the vertical are sadly off in their calculations. According to the current system of regulators the factory may count on getting 125 forints as the price of ground paprika. Thus it can buy the paprika pods at a significantly cheaper price than those enterprises which are making freely priced products and are using spice paprika as a raw material, or those private grinders who are working illegally. In contrast with the purchase price of 8.5 forints that the factory pays, the latter are paying 12-15 forints per kilogram of paprika. Thus the free market sets higher value on the spice paprika than what the industrial and consumer prices may allow.

The cultivation of paprika is not competitive in the mechanical or labor intensive fields. Thus it may happen that--as it has been squeezed out from the collective sector of the farms--it may phase out also from the small units. Its sowing area in the big farms has dropped since 1980 from 80 percent to 5 percent, since its cultivation has become unquestionably a losing proposition.

The 17 percent increase in the state purchase price, which was introduced last year, will probably not stimulate producers enough to satisfy the need of sowing area in 1986.

The price of spice paprika stagnates on the export markets. The quality of our paprika has greatly improved in comparison with earlier years, and thus we can rightly expect that our foreign trade companies will take this into consideration when concluding contracts.

Despite the tense situation there are important reserves in all producing units of this economic sector. Thus by a better and more coordinated work the cultivation of spice paprika could be made more economical, but an intervention of the central organs is indispensable for this. We need at least 30-40-percent increase in the sowing area so as to produce enough of this specifically Hungarian product, so that this economic sector might recapture its position on foreign markets.

## Market Could Be Expanded

Deputy General Manager of Monimpex Odon Beke reported on the export situation and the likely trends. This year we exported 7,000 tons of paprika, and from this amount 1,200 was sold to the ruble market. This is 1,500 tons less than

our last year's export to that area. Although, with some slipping, we met the demand on the ruble market, apparently we can also keep our capitalist customers.

As for our export prospects, we may say that we can increase our share of the world market only if we can squeeze out our competitors out of there.

On the capitalist market we could profitably sell 6,000-7,000 tons of spice paprika. The quality of our merchandise is good, but to advance further we need better capability to adapt.

There are buyers who look only for the contents, while others are only interested in the color of paprika.

Hungarian paprika is popular primarily in the German-speaking countries and in the Benelux states. In these countries cuisine is similar to ours. In Europe markets cannot be expanded because of the Spanish and Yugoslav competition, but we have good prospects in the United States and Japan. There we can hope for higher prices. Among the socialist countries the Soviet Union is our biggest customer, the current 900 tons of export could be doubled.

Spice paprika makes 10 percent of the entire turnover of Monimpex. Thus it does not matter at what price we manage to sell this product of the Kalocsa and Szeged area.

#### Our Preoccupation With This Economic Sector

It was characteristic for the interest of the experts who have met at Kalocsa that about a dozen of them took the floor. Some of them called attention to the discrediting effect of the unsteady quality of paprika ground in the households. According to the estimates about 2,000-2,500 tons of paprika ground at home appears yearly on the domestic market.

Various speakers advocated the abolition of turnover tax on paprika. It is not reasonable from the point of view of national economy to tax an economic sector which is on decline and produces little.

As a follow-up to this symposium of experts, the participants could look into the process of gathering and processing. Despite the drought good harvest is expected this year, the dryer barns in the Kek Duna cooperative of Fajsz are quickly filling up. During the post ripening process it is there that those aromas and colors develop which make Hungarian paprika so much in demand.

After drying the paprika harvest is transported to the paprika and canned food factory which belongs to the Agro-Industrial Association of the Kalocsa area. The specific aroma that surrounds the paprika mill, that of ground paprika, can be smelled already from a distance of hundreds of meters. After washing the paprika is put on the slicer and then on the dryer where its humidity contents decrease within 4-5 hours to 8 percent. From there it goes to the roller-frames, where it is being ground and eventually sifted and packed. Earlier paprika was ground with stones. In many places reddening stones are still being used for brightening the color of paprika.

The quality of paprika changes--just like that of wine according to the vintage --but its main local characteristics remain the same. Buyers are sticking to their usual brand, therefore the manufactures guarantee the steady quality with labels.

12312/7051  
CSO: 2500/160

AGRICULTURE

POLAND

SOME YOUNG PEOPLE ARE RETURNING TO AGRICULTURE

Warsaw WALKA MŁODYCH in Polish No 50, 15 Dec pp 14, 15

[Article by Wladyslaw Bielski: "They Are Returning But That Does Not Mean That It Is Spring"]

[Text] In 1982, for the first time in a long time, the number of young people beginning work in agriculture has risen by several percent. This information, coming from the Central Office of Statistics (GUS), has been repeated many times, always with an optimistic commentary. This is evidence of positive changes in agriculture itself and in village life. People reach for what is better, and today the work choices in Poland are enormous, which is borne out by the avalanche of employment want ads placed in the papers by commercial enterprises, always with the notation, "immediate openings, good working conditions."

In the years 1945-1982, 5.5 million persons moved from the villages to the cities. This process still continues, but at a slower rate than during the period of more intensive industrialization. The principal result of the migration to cities was the elimination of unemployment and dire poverty in the overpopulated villages.

Meanwhile, as time went on, negative effects of the flight of the young people from agriculture to the city were becoming evident. These were expressed, first, by the somewhat rapid aging of the farm population. A million owners of individual farms are now of retirement age, and the majority of them do not have successors. It is evident from GUS statistics that by the year 2000 every sixth village resident will be of retirement age, and in some provinces, for example, Bialostok, it will be every third or fourth. These are disquieting statistics even without considering how and to what extent the structure of agriculture in Poland will change in the next 15 years.

Second, in recent years, we have noted the phenomenon of inordinate migration from the villages to the cities by young women. Let us remember that immediately after the war, in the cities, there were 131 women to every 100 men, but in the villages, the ratio was only 117 to 100. In 1960, after the great wave of human migration from the villages to the cities, there were 108 women to every 100 men in the cities, and 101 to 100 in the villages. Today the ratio is 99 to 100.

The data cited above pertain to the whole population. In the case of the young, the situation is different and the disproportions are much greater. In the 20-29 age group (when marriages most frequently take place), in the villages there are 74 women to every 100 men: 15-20 percent of young farmers lack marriage partners.

"I might have stayed in farming," said a vocational school student in Olsztyn, "but where would I find someone to marry? All the nicer girls have left the village."

Many problems hide behind this laconic statement. Most of all there is the fear of living a solitary life, without the possibility of having a family. Many such examples can be drawn from life: after all, in the villages every second man who is somewhat older (age 25-29) is unmarried, and in the 30-34 age group, every third man. The more enterprising try their luck by paying for the services of a matrimonial bureau or advertising in the weekly papers. Also, we are aware that behind our, "Perhaps you will write me..." is frequently hidden the hope of finding friendship and perhaps a life partner.

#### Family Life without a ... Family?

The question of the possibility of having a family establishment without a family seems rhetorical. More and more often, young men follow the young women from the villages; this is what happened, for example, in the well-known "eastern wall" region where whole villages emptied out. From these places, erased from today's maps, the young women were actually the first to leave.

Thus the deterioration of the demographic structure of the village threatens the functioning of some farms. This problem has appeared or is appearing at present in all highly developed countries, and there are many reasons for this. One of the basic reasons is the great physical exertion that is connected with work in agriculture and the great amount of time required for it, particularly in animal husbandry. As is known, a living inventory requires the constant presence of man, day in and day out.

"Work in the village is hard," said another young farmer. "If one gets stuck in it, there is no turning back. The man is a slave to that calling."

Is that always so? In a system of individual land management, the problem of lack of free time is unavoidable. If we talk to owners of even the largest farms, including specialists, they all complain of excessive overwork. So increasing the size of the farm does not change the situation, quite the contrary. From the computations of the Institute of Agricultural Economics, it seems that in Poland, the most work, almost 3000 hours annually, is done on farms that are larger than 15 hectares, approximately 500 hours more than on small farms, and 1000 hours more than the average in industry.

This is due to the capriciousness of the weather, but most of all to the lack of modern means of production, and more specifically, the lack of complementarity with which these are supplied. For example, a tractor alone without the machines that go with it does not make work easier or faster and serves only as a means of transport. But without a trailer hitch, it does not serve even this function properly. Meanwhile, in most of the village farm families, if there is a successor, it is only one, which in practice means a shortage of work force. This is why those who work in agriculture must work so hard. And the results of this excessive work are not satisfying.

This overwork is also caused by the fact that the village markets constantly lack the "small items" that are indispensable in farming, pitchforks, containers for milk, nails, building materials. These things are, as a rule, not bought, but "acquired." At one time it was estimated that a farmer spends an average of 60 days annually for settling the various kinds of matters involved in the functioning of a farm. No actual data on this exist, although from observation, it would seem that the situation has not improved.

It was computed that reducing the work per person while maintaining the present level of production would require increasing the supply of capital means of production (especially machinery and equipment) by several hundred thousand zlotys. It is not difficult to imagine to what extent these expenditures will increase when we are faced with the need to double present agriculture production. This would result in a more than sixfold increase in capital investment in agriculture. This is the scale of the problem, and this is the scale of expenditures required for modernizing farming and agricultural production. At present, the lack of technical equipment is compensated for by additional work, not always with success, and frequently beyond all limits. This does not suit all young people.

The flight of the work force from the farm is an objective and irreversible process. It creates the need to make technological progress universal. If decreasing man power in agriculture is not compensated for by delivery of modern means of production by industry, then this situation will cause stagnation or a decrease in agricultural production. Therefore, the migration of the work force from agriculture is also an important reason for developing techniques and technology and organizing work.

#### The Majority Chooses the City

"What are we to do in this dead village?" asks L.O., a student. "There are only quarrels about the land, there is no machinery, there are no fertilizers, and what are we to do? plow with our hands?"

Undoubtedly, there is quite a bit of exaggeration in these opinions of the young, coming, in the case of the young people in the cities, from an inadequate knowledge of the realities of the modern village. This is, then, an indication that, in addition to everything else, we need to educate in this area (as we need to with respect to the economy in general). Meanwhile, among the students polled in Olsztyn Province, 22.7 percent were

inclined to work in the village, and 60.7 percent, in the city (the rest had no opinion on the subject yet).

Can these ratios be extrapolated to the school-age youth in general? This is the question that must be answered, obviously on the basis of a more penetrating analysis of the opinion of the potential agricultural workers.

Today we know, however, that another very important reason for the excessive migration from the farm is the lack of access to cultural advantages such as the cinema, museum and library. It is true that in more than half of the leading villages there are libraries or library points, but their outfitting does not meet the minimum requirements.

In the village, only 36 percent of the houses have running water (in the city, 90 percent); 17 percent have central heating (in the city, 60 percent); 2 percent are connected to the gas grid, and only 1 percent of nationwide electrical energy is used in the villages, including the energy used in production.

As to other aspects: 8 percent of village centers do not have a full-time doctor, and 23 percent of these have no dentist; village residents see 1/5 as many films and 1/15 as many stage productions as city dwellers.

These are historical arrears that cannot be eliminated from one year to the next. But they must be eliminated at a faster rate than has been done thus far since this is one of the conditions of changing the attitude of the young toward farming as a profession and toward the prospect of living in a village.

Without Generalizations!

What has been said above must not be generalized. Polish agriculture, as is known, is extremely varied both with respect to structure and with respect to regional set up. In provinces such as Opole, Poznan, or Leszno, for example, the problem of migration of youth to the city basically does not exist, and in any case, is not keenly felt. Land prices are high, and, on the average, the farms are larger and better equipped technologically than in the southeastern provinces. The farm infrastructure is also richer, therefore equipment for improvement of land and roads, transmission lines, supply of electricity and even cultural and social centers are better.

These factors lead the young people to have a greater interest in farming as an occupation. For this reason, eliminating the disproportion in these areas is a basic condition for systematically rejuvenating farming as an occupation, obviously to the extent that this is needed.

Meanwhile... Beginning with 1982, we have seen an increase in the interest of the young in this, the most difficult of professions. This is expressed specifically in the return of a larger number of young heirs to family farms. However, keeping in mind the regional differences, we can say that they are returning, but that still does not mean that it is spring.

AGRICULTURE

POLAND

LATEST STATISTICS ON CROP YIELDS, LIVESTOCK NUMBERS

Warsaw GROMADA-ROLNIK POLSKI in Polish 19 Nov 85 p 1

[Article by R: "Larger Herds -- Fewer Cows"]

[Text] In agriculture, we had another good year. The Central Office of Statistics (GUS) confirmed this from another aspect: the grain harvest is only slightly less than last year, and, in quintals per hectare, is 28.9; the yield on state farms was 34.8, the average for four grains; the yield of agricultural producer cooperatives was 30.8; and on individual farms, 27.7. Wheat was the best producer: 34.1 quintals per hectare; barley production was 32.8.

The GUS census of farm animals taken in October confirmed that we have more pigs and fewer cows than at the same time last year. In comparison with the third quarter of 1984, the pig herd increased by 1.8 million animals or approximately 10 percent.

The greatest increase was realized in the number of young pigs, which is due to a 9.2 percent increase in number of sows and promises a further increase in the pig herd. The larger supply of young pigs resulted in a decrease in prices by approximately 5 percent; nevertheless, in many regions, especially those with good potato harvests, there is a shortage of young pigs, and prices there are exceptionally high. For example, in Monki (Bialystok Province), the price for a pair of young pigs is 12,000-14,000 zlotys. This is good news since it promises an increase in the herd for next year.

We must not forget, however, that we still have approximately 2.5 million fewer pigs than in the years 1977-1981. We might do well also to remember that the number of pigs increased in 42 provinces, most strongly (by more than 15 percent) in the provinces of Bydgoszcz, Czestochowa, Lodz, Piotrkow, Sieradz, Slupsk, Torun and Wloclawek. Meanwhile, in the provinces of Bielsko, Chelm, Jelenia Gora, Krosno, Lublin, Tarnobrzeg and Zamosc, the last census indicated a drop in number of pigs ranging from 1.1 to 7.2 percent.

Less favorable results were noted in cattle raising. At present, we have approximately 1.2 percent fewer heads of cattle than a year ago at this time. The number of cows dropped by more than 243,000, that is, 4.2

percent. At the same time, the number of other animals increased, which indicates that there will be a greater interest in raising young cattle for fattening.

The smallest drop in numbers of cattle and cows occurred on individual farms (0.3 percent and 1.2 percent); it was more significant on socialized farms: in October, these were raising 2.8 percent fewer heads of cattle. A decrease in heads of cattle was noted in 34 provinces, the greatest occurring in the provinces of Gorzow, Przemysl and Wroclaw. In 15 provinces, there was a slight increase. The greatest (more than 2 percent) occurred in the provinces of Lodz, Ostroleka, Piotrkow, Rzeszow and Wloclawek. We must also remember that in comparison with the average situation in October in the years 1977-1981, we now have 1.6 million fewer heads of cattle.

2950

CSO 2600/210

ECONOMY

BULGARIA

ECONOMIC CRIMES, ADMINISTRATIVE INCOMPETENCE EXPOSED

Public Claim for the 103 Million Leva

Sofia TRUD in Bulgarian 17 Oct 85 p 2

[Editorial: "Irreconcilability, Personal Responsibility, Decisive Action!"]

[Text] Let us recall: debts of 103 million are owed to the state and socialist organizations. Debts resulting from embezzlement, theft, deficits, fines, crimes, squandering, punitive decrees. Debts imposed by the courts.

By publishing 'Debtors beyond the law', 'Is this democratic levelling?' and 'Benumbed cases or benumbed bailiffs' (Trud, 29, 30 and 31 May this year), the editorial staff brought a public claim for this money. In the journal's issues of 28 June and 12 July this year we gave the floor to our readers. All expressed the unanimous opinion that the debts and the interest must be collected to the very last penny.

The published materials and comments contained criticisms of aspects that had both direct and indirect connection to the process of the law -- the court, the prosecutor's office, agencies of the Ministry of Internal Affairs, legal advisers, and financial, executive and auditing agencies.

But to date there has not been a single official response giving a concrete verdict on the claim brought!

Today, we are again setting aside a section of the newspaper to the public claim. A section on personal responsibility and exigency, on control, on superfluous humanism toward embezzlers and thieves who exploit our labor. We give the floor to the miner Stoyan Buchvarov, the attorney Ivan Lalev, our correspondent in Gabrovo, Ivanka Kosseva and our readers around the country.

We remind our readers that we expect to hear the point of view of the Ministry of Justice, the chief prosecutor of the People's Republic of Bulgaria, the Ministry of Finance and the Director of the People's Militia.

A public claim for 103 million leva of the people's money, a sum that exceeds the annual budgets of many of the country's okrugs, cannot remain a voice in the wilderness.

Public opinion appeals to irreconcilability, personal responsibility and decisive action!

### Success of Gabrovo Bailiffs

Sofia TRUD in Bulgarian 17 Oct 85 p 2

[Article by Ivanka Koseva, Trud correspondent: "A rude slap in the face for all of us"]

[Text] Crime begins when exigency and control end \* Economic organizations of the profiteer Alexander (Alex the Tulip) Mikhalev's bait \* Suggestions from the bailiff's office at the regional court in Gabrovo

1. Reading the series 'Public claim for 103 million leva', every normal person would stop first to think of the conditions that encourage thieves (let's not call them by that absolving, mild and elegant name -- embezzlers). Because they are impertinent swindlers, who hold in contempt the laws of the state whose citizens they are, and the state, for its part, treads quite delicately with them. Perhaps not just delicately, but liberally. How can we explain the words of Mladen Ivanov Zakhariiev of building 24 of the Dryzhba apartment complex, Sofia "against whom six suits have been filed for 3,597 leva". Words that were thrown like mud in the face of the bailiff Violeta Dochkova: "Listen, I have the money to build a road from home to the center of Sofia, but I won't return a single lev voluntarily." For me, these words are a slap in the face for all of us, for society. Whom does Violeta Dochkova represent, and whom Mladen Zakhariiev? On whom do they rely? He -- on the opportunity to squeeze his way through the laws again and to find people, heads of departments, who have become accustomed to wave their hands breezily and say "Let him go! Big deal!" She -- on the rights and obligations of an official wearing the mantle of power. But all is not well with the mantle. It needs to be dyed to a less compromising color.

In the Gabrovo okrug, Georgi Tambyev's articles "Public claim for 103 million leva" were read and commented on for some time by hundreds of people. A retired woman, with many years service as a textile worker in Gabrovo, sought me out to talk about it. I am grateful that she bothered. At her age, most people are only concerned about their health. She ended our conversation with the old and not so popular proverb: "As soon as the pie disappears, the dish comes to light." Our people use it when something very important is missing and replaced with something of less value. Since the crafty ones have eaten the pie and left us with the empty dish, isn't it time to surround the dish, examine it, summon up our anger and see who it is that, without giving it much thought, gives away not his own pie but the common pie?

It is a fact that the words "not collectable" can be written on the file of an insolvent criminal (with no possessions whatsoever), and the 50-60 thousand leva remain simply an unpaid debt to the state. Or, another fact, you may owe money to the state or to the company where you once worked and, at the same time, have inviolable deposits of up to 1200 leva in the State Savings Bank. And, a third fact, there are no forces to compel an idle debtor to begin work.

All this sounds socially exotic to me. The legal process has limitless possibilities to impose greater severity. And greater fairness. No less are the resources and rights of those employees who bear the mantle of power in socialist organizations. Not a mantle of power that they can sleep in like a pair of warm pyjamas but a mantle that can be turned into a hedgehog's coat for crafty plunderers.

In the archives of the bailiff's office at the district court in Gabrovo, they keep the file of Alexander Minkov Mikhalev, known in Gabrovo as Alex the Tulip.

He goes by this melodious, even pretty nickname not so much on account of his love of that spring flower, nor his passion for cultivating the bulbs for its propagation, but above all on account of the deals and speculations tied in with planting, cultivating and trading the tulip, which he has accomplished with the aid of the credulity of different financial organizations. He owes over 60,000 leva, to which we can now add the claim of the RPK for another 4,328 leva. And no-one is ever going to get this money from him because he has only the shirt on his back. It is an open secret that, despite his advanced age, he still has a certain weakness and an unrevoked generosity (there are still some naive financial bosses who are filling his threadbare pockets) toward the very young ladies who frequent the most expensive spots in Gabrovo. It is inexplicable why even now some company bosses anchor their hopes in such a discredited character as him. (He was sentenced in 1972.) For example, management at the Construction and Assembly Combine signed a contract with Alexander Mikhalev last year, hoping for sure that he would compensate for some of the losses in the construction by cultivating tulips. What should we expect? A few thousand leva will probably be added to his debts. And management at the Construction and Assembly Combine will have to cultivate its own tulips because it's a well known fact that the old speculator never had a hoe in his hand. He is only the organizer and profit-taker.

What can be done. More than a hundred years ago, a great man cautioned us: "In deals of cunning, the idiot always outwits the clever man."

2. In spite of the complications and difficulties, under the leadership of the long practising attorney, Kharalan Krushev, an active, irreconcilable man, the bailiffs and the office of the bailiff in Gabrovo have had considerable experience in recent years in collecting and receiving money due, to the benefit of the state and socialist organizations. Their style of working assured them a high overfulfilment of plan in both categories of executive cases. For 1983 -- 140.8 per cent; for 1984 -- 155.2 percent. The plan for the first half of this year is also significantly overfulfilled.

Kharalan Krushev believes that the most important moment in his work is the preparation for these executive cases, collecting the maximum information about the deposits and possessions of the debtors, and also the personal contact of the bailiff with the debtor.

At that contact, he maintains, as a result of the explanatory work, by means of persuasion, many executive cases are broken off by payment even at this

stage. That is not vain talk. For 1984, the sum collected to the benefit of the state was 114,858 leva. We collected 58,119 of this, i.e. 50.6 per cent in the initial stage. And of the sum collected to the benefit of socialist organizations, 32.7 percent were collected by means of persuasion. We should not underestimate the psychological moment in the executive process. We are in constant contact with the cashiers; it's a little more difficult with legal counsel (we have to seek them out), and the assessors from the bailiff's aid department also help. We allotted to the assessors those firms in town where they had conducted audits of the cashiers and personnel departments.

We should not imagine that the bailiff's department in Gabrovo is working under special conditions. On the contrary. Here too, just like everywhere else, they receive from the people's city council reports that state: "There is no real property at this address". But it turns out that there is. Here too, ESGRAON (integrated civil registration and administrative population services system) does not provide current and accurate information. In the department's archives, there is just one letter that indicates that the debtor has a savings account. Usually the dutiful reply from the State Savings Bank is "This person does not hold an account". Here too, the secretary Vetka Georgieva, is also the bookkeeper, the cashier and the administrator. She even takes work home. And all to receive her monthly pay of 135 leva. I have described the suggestions of Kharalan Krushev. They will probably be supported by his colleagues and also by the legislative commission of the National Assembly if it concerns itself with these problems for a fourth time.

The official motion of suits to the benefit of socialist organizations should be perceived in the same way as official motion of suits to the benefit of the state. The present method of motion, at the initiative of the socialist organizations, represented by legal counsel, does not meet the new demands set by the development of our socialist society.

Let's put the district inspectors of the Ministry of Internal Affairs in charge of tracing debtors. They will save a lot of time and will refrain from the formal to and from of letter-writing.

And let the debtors with their own large homes insure the smaller ones, as theirs are sold by the people's city councils and the difference in the price of the two homes will be used to pay off the debt.

3. It is an old truth, and obviously a hot issue, that "opportunities for theft create thieves". We lose what we had gained by joint effort -- both spiritually and materially. Then what? There's no time. We must, as soon as possible, cut the knot of credulity and irresponsibility, of idleness and impunity, tied by the different attitudes toward mine and ours. Perhaps not as strictly as Krum's\* fourth law calls for: "Pilferers will have their knees smashed"; but let us preserve the national riches, our joint riches, in a determined and constant manner. And let us guarantee the return of what was taken, on time and to the penny. There's no other way.

Sofia TRUD in Bulgarian Oct 17 1985 p 2

[Readers' Letters: "To the Penny"]

[Text] From Stoyan Rakhniev, village of Dzhulyunitsa, Veliko Turnovo: If someone is a debtor, he has had his hand in the pocket of the state or the company. The state shouldn't be ashamed to reach in his pocket to take what's owed.

From Ruska Toshkova, 40 V. Sokolski St., Perushtitsa, Plovdiv: Debts should be collected to the penny -- to serve as an example to the embezzlers and to soothe the peoples' honest conscience.

From Stefan Popov, Pleven: Thieves and embezzlers are thinking only of themselves when they take from the state. Now the state must take what is owed to the penny, without thinking much of them.

From Kosta Konstantinov, Sofia: Transfers and endowments of money, valuables and all other property should be permitted only against presentation of a document that states that the person has no debts. Transfers and endowments made by people who owe money to the state and socialist organizations should be declared illegal and invalidated.

From Velyo Tomov, 201a Rakovsky St., Sofia: We need a strong and proven control to discover all those who touch public property in the embryonic stage!

From A. Todorov, 1 Mladost apartment complex, Sofia: Why are you compromising yourselves with these publications. Isn't it better, instead of concerning us with questions, to concern the Council of Ministers and other competent agencies? In my opinion, if the debtors are given a period of two months in which to pay their debts voluntarily, many of them will take advantage of that and will eradicate their debts. Otherwise, I agree that, after the voluntary period is over, all debtors should be rounded up and sent to do hard labor until they pay off their debts.

A Miner's Reply

Sofia TRUD in Bulgarian 17 Oct 85 p 2

[Letter from Stoyan Buchvarov, Miner at MOSP Obrochishte, 25 L. Karavelov St., Entry B, Apt. 4, Tolbukhin: "Aren't we becoming accomplices?"]

[Text] I read "Public claim for 103 million leva" with interest and was angry at the heroes who inflict losses on our society.

The question raised needs to be solved. The 103 million must be returned to our owner -- the people's state.

In my opinion, the chief topic to which we should turn our attention is the

responsibility. The responsibility of everyone, without exception. By defending responsibility, we raise all the high virtues of the socialist person to self criticism and criticism and generally to the dignity of socialist man. As we assess the sanctity of the material base of socialist society, isn't it fundamental to accept that all debts due to embezzlement, theft, deficits, fines, crimes and squandering are basically exploitation of man by man since they represent the good things created by all members of our society, and these squanderers have embezzled a part of them to satisfy their gluttony. Handled this way, the problem gives us the right to apply the action of the law of socialism with full force, where exploitation of man by man is abolished and its practice is most severely punished. The question is raised: Who gives us the right to withdraw from this law and to be afraid of applying its severity? As we close our eyes, aren't we becoming accomplices to these treacherous deals? A public claim for 103 million! That is the labor of hundreds and thousands of workers in our country, given for the good of the homeland, for the life of everyone.

Disregarding the role of socialist law, in which the will of the socialist worker is expressed, certain representatives of state and executive agencies have clearly given in to the temptation of the principal "You scratch my back, I'll scratch yours", which corrupts the conscience and kills all virtues. The cohabitation of such people with society is obviously demagogic, hypocritical, condescending and scornful, but never honest and open. They always operate in double-entry. There are very many examples from the rich life of Lenin, who was strict and severe toward such people.

Our socialist state has all the powerful resources to deal with such rodents of the people's welfare. But it seems that there is something rotten in the links of the control, executive and punitive agencies. What should be done? We should proceed with a scalpel to cut out the little tumors where they have settled to suck at the life-blood of our socialist construction. The longer we deliberate, the deeper they will become embedded in our body.

It would be wishful thinking to rely solely on the public claim. Everyone should take his part in resolving the problem. I believe that the debts are not 103 million, but much more. If we glance here and there, we shall come across many cases of poor management and "legal" robbery. Various social resources are used as encouragement, without knowing why those encouraged are being encouraged, etc., etc. It seems to me that a vote of undue confidence has been given to certain people who are boldly transferring socialist property into personal property. The right thing to do is to resurrect personal responsibility in deeds, not only in words. We must raise to greater heights the personal virtues of those people who selflessly defend adherence to principles, fastidiousness and impartial rigidity in the execution of their work. We have made enough compromises! It is time to reflect more profoundly on the promotion of professionals. Let them be promoted from the environment in which public assessment of their acts and their personal qualities is higher and not according to the principle "It's not what you know but who you know". That stops progress in every direction. A well formed person has a high-quality and accelerated approach to everything, everywhere. This is a person with a high coefficient of useful activity. Underscoring this, it should be understood that the blame for every failure must be borne in a

hierarchical direction by the managers. They are the people who head the collectives, and they are entrusted with rights and responsibilities. It is therefore very important, when evaluating their activities, to see to what extent these managers have used the methods for education of the public and have shown by their own example the height of socialist moral.

It is also time to improve the auditing methods. The control such as "supreme principle of confidence", as formulated by Lenin, should be conducted according to methods that would guarantee high preventative qualities. This obliges the central auditing agencies not to make great omissions in the scale of the problems when planning their work; moreover, audits should not be conducted only by local auditing agencies but once in every three or five years superrevisions should be made to confirm the quality of the audits conducted.

#### Reorganization of Bailiff's Office

Sofia TRUD in Bulgarian 17 Oct 85 p 2

[Article by Ivan Lalev: "Too many cooks spoil the broth"]

[Text] It is obvious that the organization of the bailiff's office is obsolete and that major changes have to be initiated. I am therefore suggesting that the bailiff's office be organized on the principle of a public-state basis. That could happen, for example, if they transferred to the finance department of the peoples councils, which work closely with the public. At the same time, the councils are directly supported by the agencies of the Ministry of Internal Affairs in the appropriate areas. The councils have registers of properties owned by the population, and the Work Force Department is in direct contact with the personnel departments in the companies. Also in the region are the departments of Control of Automotive Transport, which know the names of car owners, the regional committees of the Fatherland Front and the Dimitrov Communist Youth Union and the regional councils of the Bulgarian Communist Party, etc.

It would then not be difficult to find out the place of work and property--real and personal -- of the debtors and to take the necessary steps. The bailiffs have inherited a poor tradition of work that cannot be changed with the present obsolete procedures. Debtors do not appear when they are summoned to provide an inventory, the agencies of the Ministry of Internal Affairs do not execute the written dispositions for their compulsory attestation that they disclose their place of work and, if they do not work, they shrug their shoulders. The people's councils do not reply to letters concerning the status of the debtors' property, or they reply very late. As to the place of work, they don't have that information.

Very often the debtors are not employed on state work; they sell agricultural produce, work on a civil contract or on a commission and receive cash. A distress cannot therefore be levied on them. For now, punitive responsibility is being accomplished successfully, but it is somehow devoid of content. This is because the debtor who goes to prison (for embezzlement or theft) hides from people in shame. It would be quite a different situation if, after the

verdict is passed, the embezzler were sent to work in the injured company with a considerable percent of his earnings withheld and if he remained until his debt were paid. Let him experience the shame of his act, let him know that what he has taken will be repaid and that until he has paid his debt he will receive only enough to exist on. That way, everyone will think about it and they won't repeat it.

It is high time to move on to direct transfer of money from the company where the debtor works to the injured company demanding it. That will allow the demanding company to follow on a monthly basis the progress of the money due and it will save the bailiffs some superfluous work. In the present system, legal counsel sometimes take months to find the file with the information. In that time, the returns stop, and months and even years pass until the process is set in motion again. I suggest that a required percent of the charges of the executive services of the company should be transferred periodically to the sum received. This should be reflected in the balance and audited by the bank. The companies already have legal counsel, and not just one, who have been trained in legal procedures and who will have to be empowered with executive actions. That will probably be more economical for the state and more efficient for the companies.

Denial of inheritance is a legal option for debtors to circumvent the law and not pay their debts. Legal defense must be guaranteed so that the property goes to the injured companies.

I believe that if we construct an uncompromising organization of executive procedure it will be one of the most effective preventative measures of our socialist state.

#### Correction

Sofia TRUD in Bulgarian 17 Oct 85 p 2

[Correction]

[Text] The editor has received a letter from the management of the metal cutting machines plant "Metalnik" in Pazardzhik in which they contest the sum of the debts mentioned in the correspondence "Democratizing Levelling?". An audit made together with the director of legal action at the Ministry of Justice, established that the debts to the factory are 7,653.84 leva.

12907

CSO:2200/31

ECONOMY

GERMAN DEMOCRATIC REPUBLIC

TASKING MANUAL TO COORDINATE RESEARCH, DEVELOPMENT IN COMBINES

Leipzig CHEMISCHE TECHNIK in German Vol 37 No 5, May 1985 pp 183-185

[Article by doctor of economics, Dieter Bormann of the Karl-Marx University; and by Karl-Heinz Bernhardt. Report from the "Carl Schorlemmer" Technical College, Leune-Merseburg, Institute for Socialist Economic Management. Original title: "The Effective Use of R&D Projects as a Management Instrument in Innovation Processes."]

[Text] The tasking manual has proven itself as a management instrument related to the planning to such an extent as its goals are derived from the combine strategy and the performance and efficiency targets of the plan, the cooperation relationships in science and technology are organized on this basis, and with its help the performances of the research and development collectives are evaluated and stimulated. Based upon the experience of the tasking manual preparation it now depends above all upon the further qualifying of the strategic work in the combines and plants; consequently, to put through the primacy of the economic goals during the search for scientific-technical solutions, a differentiated system for checking the tasking manual is to be used, and through the rise in the degree of innovation in production a higher economic effect from science and technology is to be achieved.

The combines and plants of chemical industry spend annually considerable funds for science and technology; they have disposal over a considerable scientific-technical potential. The growing demands on the performance of the economy require the commitment of these resources with greatest economic effect and the overcoming of the contradiction arising in many combines between the increase in tasks for science and technology and an insufficient rate of innovation in the production.

Under the management measures that are directed toward this goal, the work on the tasking manual plays a decisive role. 1) The development of the tasking manual is in this case an important element of the growing role generally observed since the mid-1970's of the plan related management and planning of the scientific-technical progress. Above all this is expressed by:

- a stronger central supervision of the individual plans
- an emphatic dedication to the economic target oriented toward the economic political requirements of that time of the measures to be put into effect
- the better supervision of the complexity of the scientific-technical plans
- a strong push toward the acceleration of the scientific-technical development processes
- the closer connection between strategic and operating labor.

The goal is being pursued with the corresponding legal determinations 2) to be assigned to the tasking manual and the tasking manual project, whose solution should contribute to a new quality of management and planning in the scientific-technical endeavors. This deals particularly with making the tasking manual a decisive management instrument of the director or operations manager, respectively, during the preparation and carrying out of scientific-technical projects on tangible objects (product and technology developments). This function fulfills the tasking manual then most effectively when demanding economic and scientific-technical targets in the tasking manuals are derived from the strategic decisions on the combine development and from the plan goals in the development of performance and efficiency, when on the basis of these targets the performance contributions of the areas involved in the scientific-technical endeavors and the external partners are coordinated and controlled, and when the tasking manual accordingly is used at the same time as an instrument of performance evaluation, of performance comparison, of meeting competition, and of the stimulation of research and development. Thereby the work with the tasking manual contributes to a higher economic level of the scientific-technical results to be reached at the time of introduction, to press for a significant shortening of the time for research and transfer, and to raise the degree of innovation of the production program, particularly variety of exports, correspondingly to raise the international standards so that through the realization of the rates of innovation peculiar to the combines on an economic crosssection, an annual renovation of a third of the production volume is achieved.

Demanding management tasks follow from this with the aid of the tasking manual work the quality of the newly developed products, above all, also the vendor products, are to be improved to the extent that a general quality increase of the final products is possible in agreement with the market requirements, and at the same time the costs of the newly developed products, among them above all the materials costs in comparison with the cost level of the previous or comparison products, respectively, are reduced significantly.

The tasking manuals are also intended to set up a closer connection of planning to economic accounting in science and technology and to use the financing of scientific-technical measures as an active instrument for the increase in their economic efficiency.

Especially during 1983, the chemical industry combines have undertaken considerable efforts for raising manual work qualification. Advances, above all, as shown by investigations at the Institute for Socialistic Accounting of the Technical University "Carl Schorlemmer", were realized in the following directions:

First, the economic penetration of the scientific-technical processes was obviously improved; the economic returns of the scientific-technical labor has moved into the foreground more strongly in the thinking and actions of the manager.

Second, the directors and operating managers as well as other management areas and external partners perceive their responsibility for the scientific-technical development more comprehensively than previously.

Third, the control function of the state organs represents an advance insofar as it is made applicable by the socialist state for requirements considered significant in the scientific-technical development with great emphasis.

Fourth, the effective utilization and development of the scientific-technical potentials and their conformation to the economic needs and conditions are guaranteed better than previously.

In the case of all undisputed advances, however, the tasking manual work of the combines and plants presents a differentiated picture. The clearly task-related instrument, the tasking manual, is in part overused while it, with an appeal to its higher status, is handled partially as a replacement for the strategy and classification decisions are requested with the tasking manual preparation, which can be met only within the framework of the long-term planning work.

The tasks of the tasking manual work despite greater personal involvement of directors and operating managers as well as other specialties are observed before, as usual, mainly by the area of research and development. Above all in the case of goal setting the management areas of economy and turnover as a rule are not sufficiently considered. Naturally, the reinforced duty for cooperation of other areas and external cooperation partners does not release the area of research and development from its responsibility for demanding tasking manual targets and for their realization.

In addition, it is shown that the margin of interpretation of the suitable regulation despite the resulting definition is still relatively large. That can lead in the case of covering management to a considerable investment for the preparation and ratification of the tasking manuals and, however, pass by the general goal of labor with tasking manuals. The intent of the lawmaker consisted of the preparation of tasking manuals for such plans that lead directly to products and technologies because only in this case can the required, precise economic judgments be met as well as be confirmed as plan and balance effective. For basic research and for short-term research projects the defined regulations in the first determined stage for the enactment of the tasking manual are consequently to be applied.

A series of institutions, such as the Bureau of Standards, Measurements, and Merchandise Testing, Price Bureau, Inventions and Patent Office, and the Bank Organs, which are at present involved in the tasking manual preparation through the consent required from them, have thereby attained considerable influence possibilities over the scientific-technical work in the combines and plants. Through the further qualification of the coworkers delegated by these institutions and through a close cooperation between the combines and plants they will succeed in further limiting the difficulties arising in part with the formulation of a common standpoint to the tasking manual goals and uninterrupted consent.

The required obligations of the tasking manuals and the demand for their unconditional conformance in every detail guides the combines and research areas very strongly toward "safe" or unriskey, respectively, research goals. Doubtlessly, such goals are well planned and balanceable, but they hide the danger of small advances regarding their resulting levels and hardly lead to international peaks.

Basically, these problems must be resolved in such a manner that the management of the renovation processes becomes the main objective of management activities in the combines and plants and develops in the management collectives a complex responsibility for the efficiency of the scientific-technical progress. To this end the available management instruments--among which also the tasking manual--are qualified and to be used synchronized with each other. This applies particularly to the correlation between long-term development design, plan, instruments of economic bookkeeping, and tasking manual, by which also significantly the cooperation with superposed management levels and important cooperation partners are organized. The investigations undertaken by us confirm that for the qualified operation of the tasking manual in the management process of the combines and plants the following crucial points are decisive:

It is decisive that the directors and operating managers during the managing of the scientific-technical development processes take the point, manage personally the decisive tasks, and concentrate particularly on the main questions of the formulation of the targets, the assurance of the cooperation and the control of the shared management contributions of the specialty centers.

In this case the responsibility borderline between director or operating manager, respectively, and the center for research and development plays a special role.

A significant prerequisite for the effectiveness of the tasking manual is the qualification of the strategic labor at the approaches to the drafting of the tasking manual. Accordingly, the individual tasking manual can be derived from a strategically fixed blueprint, that shows the qualitative task break-down of the long-term combine or plant, respectively, development according to the individual plans, the position of the individual plans in the chain of plans in the development line to be followed, the magnitudes of the plans, the necessary time classification, the compactness of the plans and proceeding from this, above all, the priority and numerical series of the plan.

The starting point for the development of scientific-technical solutions is formed by the economic goals set compulsorily by the director or operating manager. For their qualified completion a close cooperation between the strategic staff, the areas of economy, procurement and sales, production, as well as research and development is necessary. In the cases of state plans and state mandates central state organs convey the corresponding goals to the combine. The search for scientific-technical solutions derived from the primacy of the economic goals is aimed at setting out the aspiring scientific-technical parameters in such a manner that they guarantee unconditionally the achievement of the economic goals. For this it is necessary to allow into the tasking manuals the processing of variants of the scientific-technical solution and naturally to define compulsorily the work in variants. The latter is preeminent-ly for such tasks the case that are of significant economic importance, show an extraordinary degree of newness, and whose potential efficiency is available only under a special risk. In addition, specific market requirements of the domestic or export sales can require the working of scientific-technical projects in variants. Accordingly, at the same time with the tasking manual to a certain extent, a working procedure is given for the research process.

In this connection a changed position in the fulfillment of the plan for science and technology seems to be necessary. Until now this plan was considered fulfilled when all individual projects were processed by the deadline. It would indeed be necessary to allow, derived from the goals of the combine development for the increase in goods production, the net production, the drop in materials and energy consumption, the increase in exports and the imports drop and such, economic goals for the plan for science and technology on the whole, whereby the totality of the project goals must assure the covering of the total economic goals and that must be evaluated as the measure for the fulfillment of the plan for science and technology. For this naturally the qualification of the projects economic evaluation and the development of governing contribution calculation is necessary, upon which the effects of individual plans can be summed up.

Costs and upper price limits are a part of the economic target of research and development projects. With their determination the result should be that through the research and development collectives economically rational scientific-technical solutions are being sought that correspond to the community requirements for the drop in labor investment. Cost and price upper limits must indeed agree with the specifics of the research and development project at that time and for that reason be built upon detailed targets, such as, for example, on the rise in export profitableness, the drop in finishing time investment, etc. The stimulating effect of the cost and price upper limits depends just as the other elements of the targets upon its well-founded preparation as well as upon the fact that its observance or underestimation is made the subject of collectives performance evaluation after the conclusion of the work.

Crucial projects, that are to be solved with the working out of the cost and price upper limits, are related to:

--lower prime prices per unit of consumption characteristics with newly developed products

--lower prime prices in comparison with the price prices of the compariosn product or the product group, respectively

--lowering the cost of newly developed products for the customer

--increasing the efficiency with the use of new work means (3).

It was proven with the cooperating partners to be considered early agreements on the cooperation requirements and possibilities are to be taken. This refers to scientific-technical performances, materials and equipment supplies, availability of pilot plant capacities in production, and the availability of investment funds. The agreement has the goal of creating prerequisites for the greatest results with the least possible investment, and in the shortest time (if possible, under 2 years).

Timely labor contacts with institutions cooperating in the confirmation of the tasking manuals and state organs contribute to being able to consider the requirements represented by them from the beginning during the preparation of the tasking manuals.

The research leader assigned the tasking manual preparation (as a rule the team leader) has the duty of taking as a basis analytical materials established by the goal proposal, especially international comparisons, competition analyses, market analyses, process analyses, installation condition diagnoses, as well as additional analytical prognostic estimations of the scientific-technical development. Proceeding from this the goals for the research and transfer with the corresponding "bombing angle" to be determined in such a manner that at the time of production and introduction to the market the international situation is determined or has a part in the determination.

An effective influence can be exerted on the work of the research collective through the financing of scientific-technical performance. In the case of the expert use of task-connected financing for the "carrying out of the scientific-technical project on the basis of the adopted tasking manual and the investment-use-calculation referred therein as well as taking as a basis the time standard for the carrying out of the research and development project" (4) above all:

--the application of the research and developpment potential aimed at the economic crucial points, and

--the striving for data that can lead to higher efficiency in the reproduction process can be supported.

The qualifying of the justifications, particularly the initial justifications, is shown in the case of participation by competent representatives of the partners involved in the task solution and expert, external assessors, who can separate critically by the goals, way to solutions and resulting effects of the scientific-technical project as a significant prerequisite for the determination of demanding goals and for observing each partner's specific responsibility for his performance toward the realizing of the targets.

To this control belong also the total economic calculation for research and development projects and the year ending calculation for science and technology (5) with whose help the economic goals of the tasking manual should be judged, the required measures for the transfer of the research and development results to production should be evaluated, and the comprehensive economic utilization of the data should be advanced.

#### BIBLIOGRAPHY

1. Weiz, H. EINHEIT 39: 204 (1984).
2. Decree on the tasking manual for research and development projects--  
Tasking Manual Decree of December 17, 1981, Legal Gazette, Section I,  
No 1 of January 14, 1982:
  1. Execution determination of the Decree on the Tasking Manual for Research and Development Projects--Tasking Manual Decree of November 23, 1983, Legal Gazette, Section I, No 36 of December 22, 1983.
3. Regulation No Pr. 475 on Cost and Price Upper Limits of April 14, 1983,  
Legal Gazette, Section I, No 12 of May 13, 1983.
4. Regulation on the Application of Economic Accounting in Research and  
Development of November 23, 1983, Legal Gazette, Section I, No 36 of  
December 22, 1983, p 387.
5. Regulation on the Total Economic Calculation for Research and Development  
Projects and the Year Ending Calculation for Science and Technology of  
November 23, 1983, Legal Gazette, Section I, No 36 of December 22, 1983.

Received on September 21, 1984

12446/6662

CSO: 2300/36

ECONOMY

GERMAN DEMOCRATIC REPUBLIC

CHEMICAL INDUSTRY SPECIFIES CRITERIA FOR RECYCLING PRODUCTS

Leipzig CHEMISCHE TECHNIK in German Vol 37 No 5, May 1985 pp 186-189

[Article by doctor of economics, Professor Eberhard Garbe of the "Carl Schorlemmer" Technical College, Leune-Merseburg, member of the GDR Chamber of Technology; and by Werner Kunth, member of the GDR Chamber of Technology. Original title: "Improvement of the Utilization of Raw Materials and (Improvement of) Finished Product Quality by Means of the Design of Products and Technologies Under the Aspect of Recycling"]

[Text] Abstract

The effect of design on the recycling of products, salvage, and waste materials in production is represented. Reasons for the need to study recycling are given, and possibilities for improving the recycling of raw materials during design and technological preparation of production are demonstrated from an economical point of view. Seven criteria for the chemical industry management are discussed. Facts: recycling; utilization of raw materials; recycling management; non-waste technology; economical criteria of recycling; degree of waste salvage; secondary material; final product quality.

Goal, Possibilities, and Status of Ultrarefining

The goal of a higher refining consists of creating an increasing new value per unit of utilized materials and invested energy through qualified labor (1). The possibilities for forcing this process are manifold. They extend from the absolute and relative reduction of consumption by production--that is, of the absolute restriction of the specific investment in fuels, raw materials, and intermediates--through the reduction of waste materials and the evaluation of secondary raw materials to the development and production of new products of a higher quality.

The process of ultrarefining accordingly has on the one hand a very sustaining effect on the increase of the available amount of use value and influences on the other hand decisively, the increase in efficiency of objective work. It has become the source for the assurance of the necessary economic growth rates. Accordingly, G. Mittag pointed out at the Conference on the Science of Economics of 1983 that national income growth for 1980 came to 6 percent,

1981 to 23 percent, and 1982 to 83 percent from the reduction of the specific production consumption. (2) Even during 1983-1984 the development continued. In the seventh SED Central Committee meeting report, it was shown that during the reporting period 75 percent of the national income growth over 6 percent became possible only through the reduction of the specific energy and materials consumption.

#### Criteria for the Design of Products and Processes Suitable for Recycling

The rising cost and diminishing supply of raw materials as well as the environmental pollution are significant motives to provide that fuels as well as raw materials and intermediates are used economically. A greater utilization can be achieved through:

- reduction of waste production, and
- raising the degree of utilization of waste products.

The design of products and processes suitable for recycling is aimed at a rational materials cycle in the economy. Economic materials cycles are characterized by the return and utilization of waste products from production lines with different successive stages of company production processes of economic final products as well as used materials and consumption wastes. The contents of production waste or remaining used materials only partially return to the natural world (natural substance cycle) but remain in the community reproduction process (3). To that extent the design of products and processes suitable for recycling leads to:

- a high degree of utilization of materials and fuels,
- a longer period of use of products (which, of course, limitingly contradicts moral abrasion),
- the slowing down of the materials cycle, and
- the possible containment and return of all useful waste and used material as production components in the reproduction process.

In the interest of a high economy of objective labor, it is, therefore, necessary to analyze the path of product manufacture in its totality, even considering byproduct aspects, from obtaining the raw material by way of processing, and the often multiple conversion or processing stages, and influencing it toward the goal including the TUL processes. It is necessary to follow product usage and product discards as used materials as far as material substance is used again as raw material, fuel, or returned safely to the natural substance cycle.

Economic substance cycles and their characteristic physical, chemical, technical-technological, and economic parameters are affected in all phases of the reproduction process. The recycling can be influenced most effectively during the R&D stage of products, processes, and technologies. In this case, waste products and used materials can be affected. Both categories of waste products can be differentiated as:

Wastes resulting from the production process and individual and community consumption. The collection and utilization can be differentiated according to the source of generation and specific problems. Production wastes (in contrast to used materials) are that portion of real substance of the objects of applied labor that were not assimilated in the production stage. The production waste products can be classified according to their source of origin (their technological cause) as:

- wastes from manufacturing and conversion processes,
- waste shavings (wastes from shaving finishing processes),
- cutting wastes,
- abrasion particles,
- processing residues of substance and energy conversion processes (slag and ashes, filtration residues, extraction residues, etc.).

According to their character exhaust gases, effluents, as well as waste heat are counted among production wastes (4).

Consumption wastes are all the residues of the individual and community consumption with the exceptions of materials resulting from the consumption process and human excrement.

Used materials in contrast are economic final products and, in fact, working materials and useful items of individual and joint consumption, that have lost their original intrinsic value totally or partially in the process of their (productive, individual, or joint) consumption, whose material substance indeed remains intact and which accordingly under certain conditions (containing, collecting, preparing) can enter the community production process anew as an object of labor. Economically important used materials are:

- scrap metal (substances of discarded products from the metal working industry),
- old textiles,
- old glass (bottles, glass scrap),
- old leather,
- scrap rubber and old plastics,
- scrap paper.

The economic final products possess, after they have been completely consumed, no value since their specific intrinsic value, the material carrier of their value, is expired. Nevertheless, the final product which is no longer useful possesses another intrinsic value--that of an object of labor.

## The Originator Principle

The originator principle fixed by law (5) presses the combines and their plants to clarify during the product development stage what must occur with the contents of the consumed or discarded chemical products. According to the originator principle basically that combine or plant bears the responsibility for waste and used material utilization in the originating jurisdiction.

This also applies to used materials from joint and individual consumption. According to this the producer (construction contractor, designer, chemical engineer...) must develop the products in such a manner that after use or wear and tear, the contents can be returned rationally to the material cycle of the economy. It depends upon the manufacture and character of a product whether and with which investment the requirement can be fulfilled after the return of the content materials into the economic or the natural materials cycle. A solution not suitable for recycling, e.g., the reinforced concrete method of construction, in which case the steel cannot be recovered for technical as well as for economic reasons.

The requirements for a design suitable for recycling for an installation, machine, or equipment are then fulfilled when these are constructed so that after dismantling a collection of pure types of potential secondary raw materials (scrap) is guaranteed. The corresponding dismantling techniques which also correspond to the principles of a rational maintenance are provided, for examples, by Robotron Combine to the customers or users of the EDR [electronic data recorder] installations. Such dismantling technologies should be a general component of the working material papers. In connection with this is also the requirement for a higher portion of useful material and the components that can be regenerated in a product. The useful material consists of directly useful components (replacement parts, doors, cables...) which are not relegated to the scrap pile.

An additional requirement consists of transforming wastes and residues into recycling materials, i.e., those that are used directly in the process in which they occur. During the pressing of thermoplastic products this leads, for example, to a utilization of approximately 98 percent. A product design suitable for recycling includes adoption of light construction and an execution suitable for corrosion resistance because this can lead to a significant easing of the flow of materials and the materials cycles.

Significant for a necessary slowing down of materials cycle is the increase in the utilization period of the products. Thus, new or improved use properties make possible an increased shelf life, longevity of product, (e.g., plastic pipes). This leads to the fact that the development of used materials per unit of time is receding. This tendency is indicated by the achieved rate of replacement of the production inventory by 18 percent even in the chemical industry.

Production aimed at quality and a small portion of final discards have also a positive effect. A quality-oriented production makes possible the extensive

utilization of the product's useful properties during the process of its consumption and can then lead to the reduction of the occurrence of wastes and used materials.

That means, however, that the producer along with the usual produce characteristics, such as functionality and reliability, must pay attention in the future particularly also to a minimum of repairs, the optimum longevity, the reduction in mass and the recovery of parts and assemblies and that he must "measure" also how he will succeed in the development of products suitable for recycling.

#### Design of Processes Suitable for Recycling

Ultrarefining requires a growing responsibility in the combines and plants for the scientific-technical preliminaries for the development of resource protecting and waste product utilizing processes as well as for the opening up of new areas of application for the secondary raw materials.

Not in every case do the production conditions in the combines and plants permit them to utilize the waste products. If the original are not capable of utilizing the waste products themselves, then according to the originator principle they must bear responsibility for the utilization of the waste products as completely as possible in those combines where on the basis of their production conditions and their production program they are capable potentially of doing so. Generally the possibilities and the economic results of the in-house utilization should first be checked since at least the savings on material and transportation costs as well as on transportation capacity indicates this. The in-house utilization of secondary raw materials developed during 1980 to 1983 more quickly in the chemical industry than in the production of industrial goods.

From the explanations so far it follows that designers of products and processes are also to be judged accordingly in the future on how successful they are in making suitable the economic necessities based upon secondary raw materials. According to the tasking manual regulation (6) before starting each research and development project concrete technical and economic goals (tasks) for the development of new products, processes, and technologies must be set. Under this aspect the tasking manual ordinance prescribes the evidence of the following economic goals:

- using domestic raw materials and utilizing secondary raw materials,
- reduction of imported raw materials, and
- optimum specific material and energy consumption (in the natural and value expressions).

For that reason the research and development departments have to take a goal oriented attitude on the occurrence and utilization of waste products and secondary raw materials. This influence must be effective in the following directions:

1. Processes producing little waste, (7)
2. Processes whose setup permits a use of secondary raw materials.
3. Processes for the separation or processing of substance mixtures (formulations) and for the recovery also of those components that are present only in small concentrations.
4. Additional economically favorable utilization possibilities for waste products already used as secondary raw materials.
5. Processes for the design of rational TUL processes for the utilization of waste products.
6. Processes for the safe elimination of waste products (if an economically useful application is not yet possible).

Level and development of the Utilization of Waste Products and the Projects Derived From It

At the moment about 11 percent of the raw material demand of the GDR is covered by secondary raw materials. For 1985 it is expected that this portion will be increased to 12 percent. It is estimated internationally that by the year 2000 the demand in raw materials and intermediates will be supplied mostly by secondary raw materials. The prognosis is that the so-called recycling industry in the developed industrial lands will take fourth or fifth place among the industrial sectors.

One such development is also planned for the GDR. Thus, there are for example 16 manufacturing plants for plastics, and among them 4 plants are qualified exclusively for the processing and sale of secondary raw materials. This emphasizes that the utilization of wastes and scrap is no temporary task within the ultrarefining process. In the chemical industry of the GDR the degree of utilization developed as follows: (8)

1976: 22.8 percent	1977: 31.6 percent	1978: 42.3 percent
1979: 55.0 percent	1982: 74.0 percent	

For the successful work in this area it can be said that the degree of utilization reached in 1982 was planned only for 1985. During the following years the following additional development of the degree of utilization is expected:

1984: 79.0 percent	1985: 80.0 percent	1990: 90.0 percent
--------------------	--------------------	--------------------

Accordingly, 15 to 20 percent of the total raw materials need of chemical industry could be filled than (1990). (2) It is noteworthy that behind the degree of utilization in 1984 to be reached at 79 percent there is a raw materials equivalent of about 9.4 million marks in secondary raw materials.

The growing requirements with regard to the transformation of wastes and scrap into secondary raw materials in the chemical industry show that so far only about 30 percent of the quantity of waste of the total industry are being used. Effective reserves are thus available in the 70 percent portion and also through the choice of the economically optimum use variant of the secondary raw material.

Where are the crucial points of interest for the further development of the secondary raw materials economy as a component of the materials economy?

#### Crucial Point 1: Additional Effective Release of Retained Waste Products

Main items are: 1) combustion residues, 2) sludges (above all also those with small concentrations of useful contents), 3) gaseous waste products, and 4) existing dumps.

Ashes, which deposit at 90 percent during the combustion of coal in power plants and whose amount of deposit is predicted for 1990 to be 25 million tons, are being utilized at this time at about 32 percent on a national scale. In contrast to this the utilization in 1970 came only 12.5 percent. Ashes from the chemical industry are utilized up to 75 percent. Great Britain in comparison points to an almost complete utilization and this above all in the construction industry.

In the cases of sludge and gaseous waste products and in the utilization of slag heaps there are still considerable reserves.

#### Crucial Point 2: Utilization of Low Tonnage Waste Products

So far little attention was paid to waste products that result in small amounts. This also applies to mixtures of substances with low concentrations. In order to open up these sources, along with economic preparative and utilization possibilities, well thought out technical-organizational solutions for collection, transportation, and preparation are required.

#### Crucial Point 3: Minimizing the Wastes

The increasing production of waste products developed by the chemical industry on the whole reversed back in 1980 although a considerable increase in ash from the increased use of lignite and lignite products should not be overlooked. In 1983 the waste accumulation came to less than 1 percent. It lay accordingly significantly below the rate of growth of the production. From 1984, the first time absolute retreat in the quantity of wastes is recorded. This development is an expression for the achievement of important advances in the development of processes and care, with the product development as well as with changes in the production program and for the success that is better than planned in carrying through the process of ultrarefining on the road to the reduction of wastes as well as through a higher coefficient of materials utilization.

The reduction in waste accumulation in the chemical industry push those products which occur in large quantities and show a relatively small degree of usefulness into the center of the scientific-technical effort. For the same reasons waste products from other industrial sectors as well as from business and individual consumption are becoming also increasingly economically more interesting.

#### Crucial Point 4: Waste Product Utilization Based Upon the Substance

The term utilization is to be understood as the use of secondary raw materials for substitution of a primary raw material corresponding to the useful and residual contents of the waste product. In industrial practice the use of wastes and scrap, that is not specific to that substance, is also in evidence. With reference to this, for example, the dumping (of ashes, etc.) into abandoned mine shafts for recalculation and the extraction of energy (burning) are forms of utilization. Because the utilization is possible in a large number of ways and the understanding of utilization has a broad definition, priorities should be set. The following series of steps should principally be decisive:

1. Direct utilization suited for that substance (e.g., repeated use of packaging materials, i.e., multiple use packaging)
2. Utilization suited for that function after regeneration
3. Utilization of all the raw material's substance in conversion and synthetic production processes
4. Utilization after use of individual properties of the raw material's substance (e.g., clinkers for construction purposes)
5. Extraction of energy
6. Utilization not suited for that substance (e.g., filling up abandoned mine shafts)

#### Crucial Point 5: Increasing the Portion of Self-utilizing Secondary Raw Materials

A positive indication for the development of the secondary raw material economy is the success in the combines in increasing the portion of self-utilized secondary raw materials. This portion grew in 1984 to about 35 percent. This development emphasizes the thesis of the priority substance matched utilization in the operational substance cycle as the economically most effective form of utilization. This development accordingly deserves in the future also special attention.

#### Crucial Point 6: Balancing the Raw Materials

The uniform balancing of the primary and secondary raw materials should be pressed expeditiously. With the balancing it is the object of the balancing

organs of the chemical industry that the secondary raw materials used as the substitute be included in the balancing of the corresponding primary raw materials. This way there was success in increasing according to plan, for example, the portion of regenerated thermoplastics for the manufacture of typical plastic products (such as shaped parts and half-finished products). There is the task of working out for all the accumulated and to be accumulated in the future waste products specific procedures for the assignment to the balance positions and of making available specific user directions to the balancing organs.

At present about 400 waste products are being collected, worked out, and set aside according to a special nomenclature. These 400 waste products do not constitute the total waste products. From this the task can be derived in the future to collect all waste products and to pursue their utilization. The central statistical studies for the years 1983 and 1984 will surely provide information on which form and to which extent from now on waste products will occur and how with them the sources for the ultrarefining are accessible.

#### Crucial Point 7: Goal Oriented Stimulation

The stimulation of the application of technologies with low waste production and a substance suited utilization of waste products as secondary raw materials needs further improvement in stages. With guidelines for the price establishment of waste products and with investment determinations for the conversion process of waste products into secondary raw materials the targets set for the area of the waste product and secondary raw material economy can be significantly supported. The stimulating regulations must interest the "producers" of waste and scrap as well as the potential users economically as to application, purchase, or sale. The principles of the time, which are applied with the return on the investment with the safe elimination, should be critically examined once again under this aspect.

#### BIBLIOGRAPHY

1. Authors Collective. Increase in the efficiency of the economical use of materials through refining processes. 13th Indentures on Socialistic Operations Management--Professional Training. Central Office for the Higher Education Correspondence Courses, Dresden, 1982.
2. Mittag, G., Theoretical Generalization of Experience in the Development of Combines for the Increase in Performance of the Economy, Particularly in the Case of the Utilization of the Qualitative Factors of Growth. Central Institute for Management for the SED Central Committee, Berlin, 1983, p 51 on.
3. Garbe, E., and Graichen, D., Secondary Raw Materials--Concepts, Facts, Perspectives. Verlag Die Wirtschaft, Berlin, 1985.
4. Garbe, E., and Graichen, D. Economic Utilization of Materials. Verlag Die Wirtschaft, Berlin, 1976, p 35 on.

5. Ordinance for the Comprehensive Utilization of Secondary Raw Materials. Legal Gazette of the GDR, Section I, No 2, 1981, p 13 on.
6. Tasking Manual Ordinance. Legal Gazette of the GDR, Section I, No 1, 1982, p 1 on.
7. Wotte, J., Dissertation B. Technical University of Dresden, Dresden, 1984.
8. Donnert, J.-J., and Kampffmeyer, P., CHEMISCHE TECHNIK 32: 381 (1980).

Manuscript received 3 September 1984

12446/6662

CSO: 2300/36

ECONOMY

GERMAN DEMOCRATIC REPUBLIC

FORESTRY ENTERPRISES ESTABLISH NEW SETTLEMENT PRICES

East Berlin SOZIALISTISCHE FORSTWIRTSCHAFT in German Vol 35 No 9, Sep 1985  
pp 276-78

[Article by Dr. E. Uhlig, Eberswalde, Institute for Forestry Sciences Eberswalde,  
Department of Branch Economics]

[Text] The effect of the differential ground-rent rules out the utilization of the valid raw wood prices as a basis for evaluating the output in forest production on an operating level. This is the reason why enterprise accounting prices are being used. These were calculated on a central base for the year 1986/1990, whereby standardization was aimed at to the greatest degree possible. The report states which methods were used in this regard in the areas of raw wood production and allocation.

Why new enterprise accounting prices?

Because it is objectively impossible to use for the evaluation of the operating efficiency a factory price derived from the industry delivery price for raw wood, the output in forest production was evaluated already in the past on the basis of operating costs for each unit of quality of the type of production activity. For this purpose, the expenditure of living labor per production unit was determined in minutes or marks (wages) for the enterprise and transferred to the enterprise accounting price by adding the costs of materials and cooperation performances, the indirect technological costs, management costs and the profit proportionately to the processing costs.

Practical experience has shown that the presently valid enterprise accounting prices are faulted with a number of objective and numerous subjective shortcomings and are therefore unable to a wide extent to fulfill their purpose. The subjective shortcomings are found primarily in the calculation of direct expenditures, with the objective faults mainly in the accounting of the remaining cost components, necessitating a methodical revision of the system for measuring the production volume for the five year plan period from 1986 to 1990. This was based on the premise that the principle of the enterprise accounting prices has proven its worth in the form of operational cost prices, and it is therefore being retained. Performance indicators reflect the work results better the more accurate the accounting prices serving their measurement are representing socially recognized expenditures. This in turn is governed by the degree of safety with which the elements used for calculating the operationally

necessary, socially recognized costs are recorded. Some of these depend on natural growth conditions, others remain unaffected and are thus easier accessible to standardization. It was necessary to solve the following tasks:

-The different natural conditions had to be included in the cost calculation according to uniform criteria.

-Standard quantities had to be calculated to the greatest possible degree for calculation elements not depending on natural conditions.

-By central calculation of costs, subjective operational effects on the amount of the enterprise accounting prices had to be excluded to the greatest degree possible.

The prerequisites for the calculation of standard calculation elements are differing in the areas of production and allocation of raw wood. For this reason different methods had to be used for keeping to the aforementioned premises. An essential basis for the accuracy of the output measurement is the subdivision of the production process according to types of production activities. They are at the same time a combination of work steps associated with respect to matter and expenditures. The structure of the frame of production activities is therefore of essential importance for measuring the production volume both during the planning stage and during accounting. A special report will be given on changes of the frame of production activities.

#### The Determination of Standard Technological Costs as a Basis of the Enterprise Accounting Prices in Raw Wood Production

Within the meaning of cost prices the enterprise accounting prices are calculated quantities. The economist familiar with cost accounting thinks thereby of the calculation scheme and that, depending on the unit of quantity of the production activity, the expenditures are determined according to types of costs and combined with the total costs. In addition, a knowledge of the individual components (individual costs) is necessary. Thus, the direct basic wage can be calculated from the standard working time given for each unit of quantity and their conversion into money. By adding the shares of time-wages, material and cooperation performance costs, as well as other cost components, the direct technological costs can be calculated and transferred to the enterprise accounting prices by way of the accounting of the indirect technological costs, the overhead costs and the contribution for social funds to the prime cost, and the latter finally by the accounting of profits. Through the knowledge of the aforementioned calculation elements, the prime costs, for instance for one hectare of afforestation, can be determined for the concrete individual area. Such a cost ratio is needed for the enterprise planning as an average for all afforestation work. A planning for partial areas based on standards and their aggregations to average enterprise rates cannot yet be realized under present conditions. For this reason, the average enterprise rates of the costs had to be calculated in a different way for each quantity unit of the type of production activity in the raw wood production. Only the socially necessary expenditures were incorporated in the calculation. This was assured by having enterprises operating to a wide extent under identical natural conditions evaluate

their performance with the same enterprise accounting prices. Through analysis of the operating expenditures, bases had to be worked out therefore

1. for the combining and assignment of the enterprises to groups of enterprises, and
2. For the calculation of average uniform enterprise accounting prices for all enterprises assigned to a group of enterprises.

-The formation of groups of enterprises:

Based on the evaluation of the cost distribution sheets (BAB II) for three consecutive years, respective calculations were carried out. After elimination of "runaways" and in combination with the distribution of tree varieties with an age of 0 to 39 years, "theoretical cost rates" per hectare of afforestation were calculated from the cost analysis and used as a basis for the formation of enterprise groups. Based on the result of these calculations the following three main groups were formed: 39 pine enterprises with a proportion of pines exceeding 50 percent, 16 mixed enterprises in which no tree variety is represented with more than 50 percent, and 17 spruce enterprises with spruce share of more than 50 percent.

Since the mixture proportions of the tree varieties within these groups still differ greatly, further subdivisions had to be undertaken, so that finally seven groups were formed for pine enterprises, five for mixed and eight for spruce enterprises. The enterprises with more than 50 to 90 percent and those with more than 90 percent smoke-damaged areas were given special consideration. In the areas of types 3 and 4 of the production activities the spreading of costs was less severe. Thus, identical cost rates were determined for different groups, resulting in the end in a reduction of the number of groups.

-The calculation of group-specific average technological costs:

After assigning the enterprises to the enterprise groups, the costs were determined according to the types of costs per unit of quantity of the type of production activity. The three-year average of the actual costs of the enterprises belonging to the group was used as a basis. Price changes already existing at the time of the calculation and becoming effective in the period of 1986/1990 were worked in. This applied to the prices for forest plants. With inclusion of the distribution of tree varieties group-average coefficients were calculated from the price change coefficients of the tree varieties. These were used to correct the cost rates of the cost type 'material for the production activity types afforestation and repair.' In this regard the inaccuracy had to be accepted that the type of cost 'material' cannot only contain the pure cost of plants, but also contain expenditures not subject to changes in industrial prices (e.g., transportation or warehousing of the plants). The direct technological costs were determined by adding the cost rates of the individual types of costs. To the latter was added the share of indirect technological costs as a group average in relation to the basic wage rate of direct technological costs which resulted in standard technological costs per hectare and type of production activity typical for the group. This basic scheme

was applied to all calculable types of production activities in the activity areas two to four. Some of these production activities required special calculations and, in part, subordinations. Thus, the two types of production activities existing at present for clearing will be changed in the future to "cut unusable low growth," "clearing of cut brushwood," and "removal of cut brushwood." According to logical aspects pertaining to the matter and after consultation with experts in the field, a ratio of 30:50:20 was determined for pine and mixed enterprises, and one of 20:60:20 for spruce enterprises, from the average total cost rate per hectare of clearing. A similar procedure was followed with the types of production activities in the cultivation of young growth and young timber.

The deeper structuring of the production process carried out with the new framework of production activities, which confirms better to practical conditions, required the establishment of cost relations between old and new types of production activities. Differences of opinion existed with respect to a cost rate for the new type of production activity 316 "cultivation of young timber outside of the optimal range of altitude." While a part of the experts spoke up in favor of the type of production activity and thus for a special accounting of costs, opinions were expressed to the effect that the first afforestation must attain a state of cultivation of the timber which would make any work pertaining to cultivation of the timber unnecessary in the future. A compromise was found to the effect that a cost rate of 25 percent of that calculated for "cultivation of young timber at optimal altitudes" was granted for these performances. It should be pointed out in particular in this connection that only those services pertaining to the cultivation of young timber stand are compensated by the enterprise accounting prices which have to be undertaken for the purpose of cultivating the timber. These include the necessary removal of dead, suppressed and unusable material. The higher expenditures necessary by the first thinning out for the exploitation of raw wood are taken into account in the respective applicable enterprise accounting prices.

-Special arrangements for areas of production activities in raw wood production:

As formerly, the production volume for some production activities cannot be calculated in the future either by multiplying the production quantity with a price for the unit of quantity, as the production and cost planning would have to be itemized for this purpose (for instance road construction). The technological costs are therefore determined by the enterprise as a total sum based on valid unit prices. This volume is checked and verified by the Department of Forestry of the responsible regional council.

Determination of Standard Technological Costs as a Basis of Enterprise Accounting Prices in the Allocation of Raw Wood

The expenditure of labor necessary in the respective enterprise in minutes per  $m^3$  is used as the starting quantity for the calculation of the expenditure per  $m^3$  of a given group of assorted raw wood. This expenditure of labor depends on the structure of the forest subsoil, the conditions of strength, height, and branches as a result of it, as well as terrain conditions and other factors. BINDER calculated this expenditure of work hours with a special EDP program for each StFB (state-controlled forest enterprise). The timber stand data to

be recalled from the data storage 'forest subsoil' and the catalog of operating time standards--socialist forest economy--were used for this purpose. The concept of utilization provided by the forest facility was used as a basis. The standard extra charge resulting from the condition of the timber stand and terrain for work-aggravating factors was then added to the base standard expenditure calculated above. Other labor-aggravating factors were included in the calculation at an average rate.

The following were calculated: Standard time allowances for felling, debranching, and removing the top ends of the timber per  $m^3$  of long timber, as well as the shaping into assorted layers of wood at the cutting site. Used as a basis were wood-specific shares of shaping wood layers from crown and long wood. The motor saw technology was selected as the uniform technological basis.

The standards without aggravation-extra-charges were calculated for the shaping of long raw timber into timber layers at timber shaping sites. The same standards apply also for the shaping at stationary sites.

The thus calculated standard time targets provide assurance that the socially necessary expenditure established in the catalog of time standards is granted for qualitatively and quantitatively equal units of raw timber felled under the same natural conditions. Differences in the absolute extent of the time standard given per  $m^3$  are then caused by variable characteristics of the forest subsoil.

-To convert the time into money accounting, the monetary value per planned hour or minute respectively is determined by utilization of table 407 (work team accounting) of lumberjack brigades. Taking into account the annual increase of the average wage in the area of raw timber allocation, a quantity of M 5.64 per standard planned hour resulted for the year 1990.

-Aside from the time for which output-linked (piece rate) wages are paid, productive time-wage hours occur also in lumbering. An analysis of the wage records of enterprises selected at random showed a time-wage share of 11.5 percent pertaining to standard time.

Apart from wage expenditures for productive activities, wages in the unproductive area arise with the cost types 420 to 429 (vacations, holidays, and paid non-production hours). The latter are calculable and must therefore be included in the calculation of the technical costs.

The percentage determined for vacations and holidays was 9.6 percent, while that for paid non-production hours--taking into account the standard wage rate for it--was 14.3 percent.

-For the cost type of depreciation, material, cooperative and repair work, other productive work and travel costs, the expenditures were calculated in  $M/m^3$ .

-Based on the catalog "Standard and Approximate Values for Application in the State and Executive Organs of the Agricultural, Forest and Foodstuff Economy--Norms and Guide Values," the fuel requirement was calculated per  $m^3$  of the groups of assorted raw timber as an average value and a contribution of M 2.14 per liter of fuel was calculated by including the lubricant requirements.

-A special problem was the calculation of a central standard for the transportation of workers to and from the work site. The costs actually incurred for this purpose are widely spread. A correlation to the size of the enterprise could not be determined. For this reason, a uniform amount of M 3.50 per cubic meter of felled wood was fixed on a central basis.

-As a share of the enterprise for social insurance (SV) and voluntary supplementary pension insurance (FZR) 11 percent are to be included in the calculation in relation to the total wages.

By means of these building blocks it is possible to calculate the standard technological costs per m<sup>3</sup> raw wood, arranged according to the valid groups of raw wood types and taking into consideration the natural conditions, as typical for the respective enterprise.

With a target of 60 minutes basic and premium standard for the production of one m<sup>3</sup> pine, average trunk 0.20 m<sup>3</sup>, lots of branches 3.5, the following calculation applies:

1. Basic and premium standard	M 5.64
2. Proportionate time-wage, vacation and non-production hours (35.4% of line 1)	M 2.00
3. Fuels and lubricants	M 0.45
4. Write-offs	M 0.16
5. Miscellaneous and other material	M 0.91
6. Cooperative performances	M 0.57
7. Repairs	M 1.26
8. Transportation of workers	M 3.50
9. Other productive performances	M 0.08
10. Travel money	M 0.23
11. Share of social insurance and voluntary supplementary pension insurance of the enterprise (11% of lines 1 + 2)	M 0.84
<hr/>	
12. Standard technical costs	M 15.64
<hr/>	

The Derivation of the Enterprise Accounting Prices and Expenditure Limits from the Standard Technological Costs

By accounting of the management costs, the contribution for social funds and of profit shares, the technical costs are transferred per unit of quantity of the type of production activity to the enterprise accounting prices.

-The management costs were also related to the wages. Taking into account the real estate tax, an amount of M 0.80 management costs per mark of wages resulted for the forest production.

-Pursuant to the "Decree on the Contribution for Social Funds" of April 14, 1983 (GB1. I No. 11 p 105) and calculation instructions issued in this respect, this contribution is calculable and thus a component of the prices. Its absolute amount comprises 70 percent of the planned wage fund for workers and employees. An amount of 89.1 percent of the wages contained in the technical costs was calculated for the enterprise accounting prices.

-The standard rate of profit calculated on wages + participation fund (?) for the forestry production is 94.2 percent.

With the last figures cited all calculation elements for the enterprise accounting prices have been submitted. These were calculated centrally for all state-run forest enterprises. An enterprise accounting price of M 42.17 results for the example cited last. The expenditure limits (AWL) are to be determined according to the same rule by the enterprises with the planning, and for the accounting according to the actually expended costs.

A separate article will report on the application of these prices in planning and accounting, and on the indicators to be calculated with their aid.

12693/7051  
CSO: 2300/47

ECONOMY

GERMAN DEMOCRATIC REPUBLIC

## FORESTRY INDUSTRY DESIGNS FINANCIAL PLANS FOR 1986-1990

East Berlin SOZIALISTISCHE FORSTWIRTSCHAFT in German Vol 35 No 9, Sep 1985  
pp 278-79

[Article by Dr. Habil. W. Binder, Dr. E. Engelhardt, E. Neuendorf, Potsdam Central Work Group for Planning, Accounting, and Statistics]

[Text] The forestry guidelines for the years 1986 to 1990 were worked out by the Central Work Group for Planning, Accounting, and Statistics in close cooperation with central agencies, the science, and representatives in the field. Resolutions adopted by the party and government with the objective of increasing the output and effectiveness stood hereby in the foreground.

The demand for a reduction of costs and an improvement of the expenditures and the result is to be supported by the planning of costs and financing. Some selected problems shall be dealt with in the following.

### Framework of Production Activities

The framework of production activities was also worked over for the period from 1986 to 1990, and the necessary changes resulting from the requirements of practical application and science were made. In the production activity area timber establishment, a subdivision according to tree types and groups of tree types, respectively, was carried out in the re-forestation work. Newly included are the production activities re-forestation in the smoke damage zone I to III with the subdivision according to types of trees, accomplished regeneration of nature, subsequent afforestation and pre-forest. The production activities 'subsequent afforestation and pre-forest' were required to conform with the principles of forest cultivation in the GDR.

The changes in the cultivation of young growth and young forest resulting from the principles of forest management of the GDR, as well as the cultivation of timber standard were worked in.

In the production activity area 'allocation of raw timber', a binding subdivision was carried out again for the felling and shaping of raw timber in the forest according to similar types of expenditure groups in planning and accounting. In addition, the shaping from long raw timber and the chopping of long raw timber in the forest were established as separate production activities. Moreover, because of the difference in expenditures,  $L_1$  of the young timber

cultivation and  $L_1$  of the timber cultivation will be covered and evaluated in the future in separate production activities.

In order to take the variable conditions created by the use of special technical methods in the allocation of raw timber into account in the standard planning, special production activities (planning of cost surcharges) were created.

#### Standard Planning

In the cost and finance plan table (plan 811, page 4), the standard and plan costs are determined for the production and allocation of raw timber.

As is known, the production conditions in forestry are very variable, making the objective initial planning targets difficult. By the introduction of standard costs after 1986, an attempt will be made to better meet these variable production conditions in setting the planning targets. Comprehensive preliminary work has been done in this respect in cooperation with the state-run forest enterprises and the departments of forestry in the area of tree felling. Unfortunately, this covers for the present only a part of the afforestation work, although this part too is quite important. Work is proceeding on the deepening and broadening of these fundamentals.

The principle used for the derivation of standard costs is based on the formation of groups for planned utilization timber which, with regard to possible technological variants and the required expenditures for making available types of timber to be held out, are to be evaluated as identical or similar. The criteria for this grouping and the planned quantities of timber types originate from the data storage 'Forest Fund' with the five-year planning.

The standard times are taken from the industry-wide catalog of time standards (the mean unit volume is playing a large role in it) for the expenditure (depending on the technological variants) and are increased by extra charges for the type of terrain, timber (including first work intervention) etc. This is done for each work performed. The necessary operations are added for holding out the types of utility timber according to plan 116.

The thus defined targets for these groups of utility timber are basically the same in the entire branch of the economy. Differences in the targets for the state-run forestry enterprises and districts result from the fact that in the district of Cottbus, for instance, the criteria for the groups of utility timber are completely different than those in the districts of Suhl or Rostock. The step from the time standards to the standard costs was executed in that way that the technological cost ratios were calculated per standard hour for the various technical processes and compared with the actual rate as an average for the entire economic sector. In 1984 the difference between the actual and standard costs was 6 percent (standard costs below the actual costs). The departments of forestry at the district councils receive these standard costs as rates per type of production activity, with subdivisions for each state-run forestry enterprise. These technological cost ratios constitute the bases of calculation for the standard costs in the planning process. The bases of calculation are revised annually if the prerequisites change (wages, prices, technologies, etc.).

The existing techniques in the districts were taken into consideration in deriving the standard costs, although without large units, such as, e.g., advancing wood-cutting machines. Special charges are applicable for the latter.

The explained approximation of the level of the standard costs to the actual costs at an average for the economic sector has the result that good state-run forestry enterprises or also entire districts are better than required by the standard costs. The gap between the planned and standard costs in these cases is negative. If that is not caused by especially favorable conditions (for instance compact forest areas with little transport of workers and transplantation costs), it must be evaluated as an above-average performance of the respective state-run forestry enterprise or forestry department.

The state-run forestry enterprises have the possibility of putting the standard costs down with a program for the office computer (NOR-PLA-BC) in form of a standard wood-cutting plan. An increasing number of the state-run forestry enterprises makes use of it.

#### Transfers and Additions for Raw Timber

The differential equalization for the forest production (production and allocation of raw timber) is retained according to the methods applied during the five-year plan period from 1981-1985, and the principle of the self-generation of resources is thus guaranteed for every state-run forestry enterprise.

Independent of the timber proceeds attained, the amount of which is determined decisively by the existing timber supply and not by the economic management, each of the state-run forestry enterprises receives as much in funds as it needs for the maintenance of a continuous production process and the forming of funds. The rest is to be paid out with higher timber proceeds. In the event that the timber proceeds are insufficient, an addition in funds will be made. The costs are determined with the aid of enterprise accounting prices which are normative in character.

They contain both the prime cost and the profit components which were calculated on the basis of a central rate.

#### Management Costs

In plan 811 page 1 (derivation of the operating result) the setting off of the management costs against the production activities and, respectively, the cost center areas was waived, since the values in the plan and in accounting did not change and a deviation in management costs was registered only in one amount. In order to simplify the planning, the management costs are therefore planned only in summary.

#### Financial Relations

In the financial relations (plan 811 page 2) modifications were made in the product-bound levies and price supports. Only levies and supports effecting the household are included in the financial relations. The determination has to be carried out according to the legal stipulations, taking into account the price equalization additions and transfers.

## Cost Development Through Measures of the Scientific-Technical Progress (STP)

In order to demonstrate the economic benefit of the scientific-technical progress, the values were taken over from the measure sheets into plan 322.

The exact proof of the planned effectiveness of the cost reductions is to be shown in the plan--cost distribution sheet on special production activities and cost centers respectively. The cost reduction in the economic benefit plan of the STP must conform to the cost plan (plan--cost distribution sheets).

## Financing of Working Capital

The determination of the permanent assets/liabilities was included already in 1985 in the calculation of own resources in the financing of working capital. In determining the permanent assets/liabilities one proceeded on the assumption that theoretically the daily production costs are being financed from the daily proceeds, with surpluses transferred and deficits made up by additions daily.

All payment processes running counter to this financing rhythm shall be taken into account in determining the permanent assets/liabilities.

Permanent assets are receivables of the enterprise accruing from advance payments for rentals, leases, or the like.

They cause financial requirements to be determined by financial planning, so as to provide the enterprise with the necessary financial resources.

Permanent liabilities are financial resources made available to the enterprises on a temporary basis as a result of the diverging dates of inception of liabilities and payment. They arise before the payment of wages and salaries and prior to the transfer of contributions to the social insurance, of net profit, PFA, and similar items. The total of permanent assets is to be deducted from the total of the permanent liabilities. The difference in the amount serves as the source of financing for the working capital.

12693/7051

CSO: 2300/47

ECONOMY

GERMAN DEMOCRATIC REPUBLIC

#### INNOVATIONS IN BROWN COAL MINING ASSESSED

East Berlin PRESSE-INFORMATIONEN in German No 138, 28 Nov 85 p 6

[Article under rubric "Numbers and Facts": "Brown Coal From New Open Pit Mines"]

[Text] The new open pit mine capacities put into operation since 1981 contributed to the fact that the workers in the lignite industry could provide from year to year more crude brown coal. If in 1981 267 million tons per year were reported, there are at present much more than 300 million tons. At the same time it became possible to make up the losses arising from the depletion of deposits. Four pit mines had to halt their operations since 1981 because the coal reserves had been exhausted.

Half of the coal increase since 1981 is to be traced to the reinforced intensification in the existing pit mines; the other half results from eight pit mines that were newly opened. In 1981 these were the pit mines Cottbus-Nord and Cospuden, in 1983 Spreetal-Nordost, in 1984 Dreiweibern/Lohsa, Bockwitz bei Borna, as well as Graebendorf, in 1985 Koeckern and Scheibe. The capacity of these pit mines reaches 40 million tons of crude lignite per year.

The importance of this development can be seen in the following facts: if in 1981 66.6 percent of the energy need of the GDR was covered by our domestic crude lignite, then it is at present 72 percent. Population and economy could be supplied at any time reliably with energy. Almost the whole mined quantity of coal is refined and made available to the users in the form of briquets, electrical energy, gas, or long-range heating. The portion of the coal that is processed further into raw materials for chemical industry could also be increased.

During the last five years the geological conditions for the mining of crude lignite have become more complicated. If in 1981 4.2 cubic meters of rubble must be removed in order to expose one ton of coal, then this performance rose at present even to 4.5 cubic meters. The pit mines are becoming deeper. The average shaft comes to 71 meters at this time. Some pit mines, for example, the pit mines of Berzdorf and Welzow-Sued, have exceeded the depth of 100 meters already. The expenditure for lowering the water in the pit mines, an unavoidable prerequisite for the safety of the miners and the installations, has risen. In order to mine a ton of coal, about 6 cubic meters of ground and surface water must be pumped out.

The workers in the brown coal industry meet the geological, hydrological, and mining technology conditions, that have become more complicated, for mining coal with new technologies, which strengthen the application of microelectronics, performance electronics, and robot technology, which accelerate the simplification and modernization of equipment and outfitting. For example, in this manner the performance of the big rubble removing conveyor with a lifting height of 60 meters could be increased from about 95 million cubic meters per conveyor annually to an average of 111 million cubic meters. By means of the conveyor technology over half of the total rubble is moved.

Increasingly the productive conveyor belt technology is coming into use for the handling of rubble. Through the introduction of an additional 5 conveyor belt installations it was possible to reduce the uneconomical removal with the carts. If in 1981 25 percent of the rubble was still removed with wagons, it is at present 19 percent. The portion, which is transported by the significantly more effectively operating conveyor belt installations, rose from 22 percent in 1981 to at present 29 percent. If a miner using the mine train using the available technology is capable of moving hourly 10 cubic meters of rubble, then with the conveyor belt technology he achieves 27 cubic meters. With some installations, such as in the pit mines of Meuro and Greifenhein, peak values of even around 50 cubic meters were obtained.

A decisive role, especially for the newly opened pit mines, is played by the reuse of large equipment from depleted mines that had been previously modernized to increase performance. The increase in performance lies between 10 and 20 percent. Thanks to intensive scientific-technical labor technological solutions are available that make it possible to just about transfer all types of equipment including the rubble carrying conveyor belts to other pit mines. A total of 92 pieces of large mining equipment--excavators, dumpers, and belt carriers--from 1981 until now were in the VE Brown Coal Combines of Bitterfeld and Senftenberg. At the new sites of use they all contribute to the mining of more crude lignite.

Valuable simplification assistance is provided by the VE Combine for Lignite Installation Construction, which since 1981 until now tripled the production of improvement materials. Among other things the finishing of complete conveyor belt installations and universally applicable tools were newly taken up in the production catalog. Three conveyor belt installations for the pit mines of Cospuden, Scheibe, and Espenhain have already been set up. To the south of Leipzig a new modern plant was constructed for the production of replacement parts and parts exposed to abrasion; this is the VEB Steel and Case-Hardened Casting Foundry in Boesdorf.

Only 570 industrial robots were introduced during the last five years into the lignite industry that were almost exclusively manufactured in the lignite works own improvement means construction plant. Thereby 1,600 workers were made available for other work. A larger portion took on important tasks in the new pit mines.

The opening up of new open pit mines is connected with extensive consequences for the region and its citizens. At present 12 hectares of surface must be claimed in order to expose and mine one million tons of coal. The uppermost consideration is to keep the effects on the population, agriculture, and traffic as small as possible. This requires the preparation of all measures, including the shifting of buildings and installations, roads and rivers, on a long-term basis with the local authorities and their councils in the affected districts. All the necessary steps, such as the leveling of villages, the transfer of their citizens, the building of new homes, as well as the form of the fields returned after mining are determined years ahead thoroughly together in concert and in detail with the citizens.

The task of returning exhausted and refilled strip mine surfaces to agriculture and forestry at the earliest point in time possible and in good quality is observed by the workers in the lignite industry with great responsibility. Since 1981 until today 8,200 hectares were reclaimed and transferred to new utilizations. These are 800 hectares more than originally foreseen. The further improvement in the quality of these fields was successful at the same time. Manifold measures such as irrigation and soil enrichment contribute to bringing its yield capacity to the original level in a short time.

12446/12795  
CSO: 2300/104

MILITARY

INTERNATIONAL AFFAIRS

WARSAW PACT NAVIES USING TARANTUL-I PATROL BOAT

Frankfurt SOLDAT UND TECHNIK in German No 11, Nov 85 pp 700, 703

[Article by Siegfried Breyer: "Export Model for Third Countries"]

[Text] It appears by now certain that the TARANTUL-I class, observed on the open sea for the first time in January 1979, is being built for export to third countries, primarily probably to states integrated in the Warsaw Pact. Apart from one representative unit of its class which travels under Soviet colors<sup>1</sup> there are at present three units in the Polish Navy and two in the GDR Volksmarine. As reported in the latest edition of the well-known British naval handbook,<sup>2</sup> Poland is to receive a total of eight units; the number of the GDR has either not yet been determined or not been published. According to the same source, India is said to have placed an order for five units. In Poland as well as in the GDR these new boats are to replace the obsolescent missile speedboats of the OSA-I-class.<sup>3</sup>

The TARANTUL-I class appears to be a development of the second half of the 1970's and may be considered as a combat model in the configuration of an enlarged missile speedboat designed for use in the ocean-bordering seas or forward coastal areas. Heading their military specifications were no doubt greater platform stability, improved seaworthiness and probably greater endurance at sea.

The use of a standardized hull appears to have economic advantages. At least in its exterior design, it is identical with that of the PAUK class submarine hunters, which have also been entering the inventory since 1979. The main shipyard (and probably the managing shipyard) is the Petrovskiy Yard in Leningrad; in addition, there is participation in this program by the Izhora shipyard in nearby Kolpino and the Volodarskiy Yard in Rybinsk, but, it appears, only for construction of the apparently combat effectiveness upgraded TARANTUL-II class<sup>4</sup>; cooperation between the shipyards is said to take the form of the managing yard building the hulls while the secondary yards--e.g., the one in Kolpino--take care of the completion and installation of equipment. Until the middle of 1983 four shipyards are said to have been participating, which indicates the probability of a large series.

The ships, constructed with flat decks, have bent ribs starting at the stern and running close to the bow. Below the bent ribs the hull is noticeably

concave toward the interior of the ship. Toward the rear, the upper deck is well rounded off and strongly slants upward, possibly to provide room for installing the gas turbines or their exhaust lines. The exhaust openings are located on the square stern and can be closed off with flaps. The length-to-width ratio of these ships, always measured at the construction waterline, is approximately 5:4. Height at the sides is calculated at 5.5 to 6 meters. The ships have a combined gas turbine/diesel engine powerplant, apparently in CODOG circuit, consisting of two 8,830 kW (about 12,000 PS) gas turbines for high-speed runs and two 1,470 kW (about 2,000 PS) diesel engines for cruising. The gas turbines drive the side shafts and the diesel engine the central shaft. Variable pitch propellers are as likely to be present as are fin stabilizers. With their estimated speed of 40 knots they are the equal of the OSA-class missile speedboats.

Armament consists of the following: two twin launch containers, facing about 8° to the right front, each located to one side of the central superstructure and containing one SS-N-2C missile; one L/55 76-mm gun near the front of the ship; two ADMG 630 Gatling automatic antiaircraft guns at the rear end of the upper deck superstructure; and a quadruple launcher for the SA-N-5 ship-to-air missile weapon system on the rear deck. The missiles of the SS-N-2C weapon system have Seaskimmer properties<sup>5</sup> and are thus more difficult for radar to acquire, which makes the defense against them more difficult. This technology, which is here being used by the Soviets for the first time, represents an increased threat factor for the German Navy; ships thus equipped gain a substantial increase in combat efficiency on the one hand, while on the other hand the options for defense against them is reduced.

The extreme forward position of the 76-mm gun may be a solution to the requirement for an optimum firing angle. The gun turret, which can be rotated by 360°, can cover a 320° sector with its fire and could, at least in theory, fire at aerial targets to the rear of the ship beyond the mast at maximum tube elevation. If the turret were to be located only 3 meters further to the rear, the sector would be reduced to less than 300°.

Note should be taken also of the air defense component. Along with the close range SA-N-5 missile weapon system, it can be assumed that the old GRAIL (SA-7) has been replaced with the GREMLIN (SA-14), which has been developed and introduced as its successor.

The electronic equipment of the TARANTUL-I class is composed of instruments most of which have been in use for a number of years. Only the PLANK SHAVE surveillance radar comes from a more recent development period. It is located atop the mast.

The units traveling under the Polish and GDR colors differ in their architectural exterior not only from each other, but also from the ship remaining in the Soviet Navy. The points of difference all lie amidships and mainly concern the construction of the funnel and air supply ducts; but generally they are not significant enough to warrant further discussion here-- the illustrations make them sufficiently clear. However, we should mention

the external differences which become manifest in the TARANTUL-II class: apart from the BAND STAND radome installed on their bridge superstructure, their mast is less severely angled; on top of it sits a spheric radom (LIGHT BULB).

Poland was the first country to have TARANTUL-I units delivered to its Navy. There are three now, as shown in Chart 2.

The names of the ships shown in Chart 2 are Polish occupational designations: GORNIK stands for miner; HUTNIK for coal miner, and STOCZNIOWIEC for shipyard worker.

The next country to receive these units was the GDR (Chart 3).

Possession of these units considerably upgrades the combat effectiveness of the Polish Navy and the NVA People's Navy, thus gaining a great increase in offensive combat potential. This permits the conclusion that both navies, whose composition to date appeared oriented toward the role of supporting or securing the Soviet Baltic Fleet, have now been integrated into a concept leaning more toward offensive operations.

#### FOOTNOTES

1. This ship is probably being made available for training those foreign crew cadres which are later on to receive TARANTUL-I class units. The same procedure is used for the KONI class.
2. "Jane's Fighting Ships 1985/96," London 1985, p 404.
3. Inasmuch as Poland and the GDR have approximately the same number of OSA-I units and Poland is to receive eight TARANTUL-I's, the same number of units can be assumed to be intended for the Volksmarine. This would result in quota of about one TARANTUL-I for every two OSA-I.
4. The TARANTUL-II class, which has to date been reserved for the Soviet Navy, includes one unit equipped with SS-N-22 missiles for test purposes.
5. See also SOLDAT UND TECHNIK No. 4/85, p 214 et seq: Weapon Systems of Soviet Warships (VI): SS-N-2 and its variants.

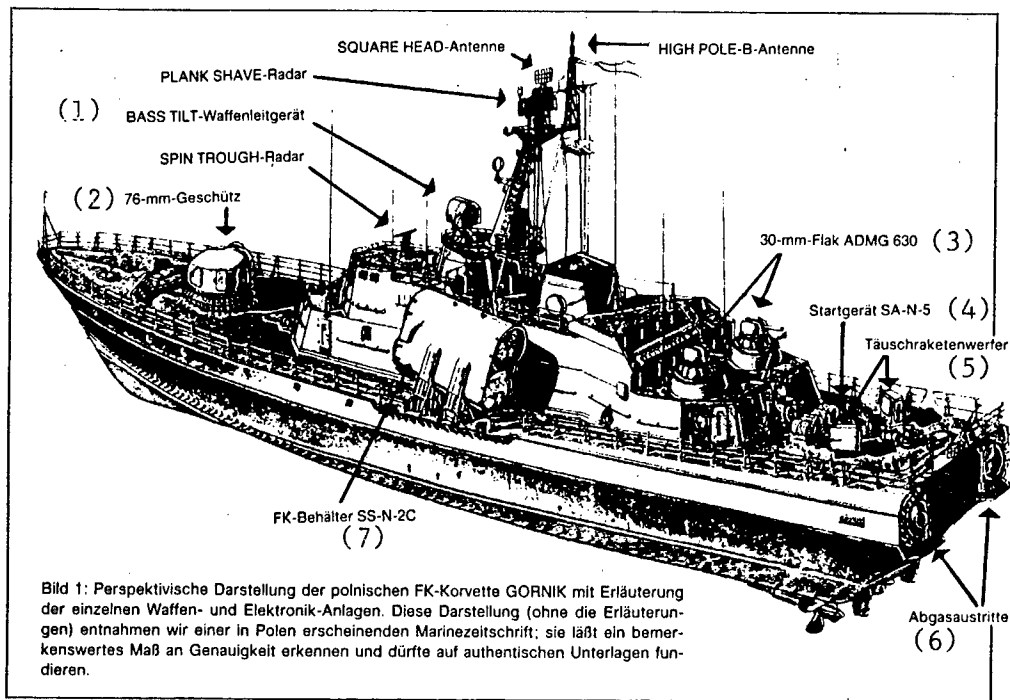

Figure 1. Perspective drawing of the Polish missile corvette GORNIK, showing individual weapon and electronics systems. This illustration (without explanatory captions) was taken from a Navy periodical published in Poland; it appears very accurate in its details and is probably based on authentic data.

Key:

1. BASS TILT fire control instrument
2. 76-mm gun
3. ADMG 630 30-mm antiaircraft gun
4. SA-N-5 launcher
5. Decoy missile launcher
6. Exhaust openings
7. SS-N-2C missile containers

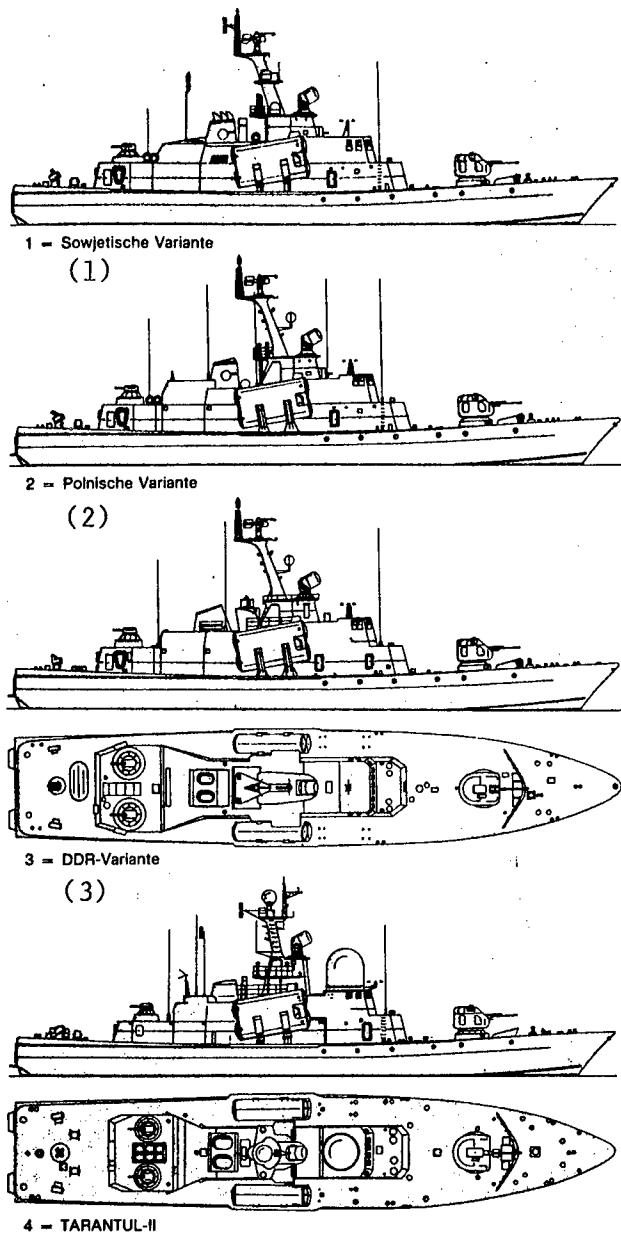

Figure 2. Drawings of the three TARANTUL-I versions, in comparison with TARANTUL-II.

- Key:
- 1. Soviet version
  - 2. Polish version
  - 3. GDR version

Chart 1. Specifications for the TARANTUL-I Class

---

Operational Displacement:	550 metric tons
Standard Displacement:	480 metric tons
Overall Length:	56.5 meters
Length at the Construction Waterline:	52.3 meters
Width at Upper Deck:	10.5 meters
Width at the Construction Waterline:	9.5 meters
Maximum Draft:	2.5 meters

---

Power Plant:	2 gas turbines and 2 diesel engines in CODOG circuit
Propulsive Output:	17,660 (24,000) plus 2,940 (4,000) kW (PS)
Drive Shafts:	3
Rudders:	3(?)
Speed:	40 knots
Fuel:	about 50 metric tons

---

Armament:	2x2 SS-N-2C (4 missiles) 1x4 SA-N-5 (16 missiles) 1x1 L/55 76-mm gun 2x6 ADMG 630 30-mm gun
-----------	--

---

Electronics:	1 PLANK SHAVE Surveillance Radar 1 SPIN TROUGH Navigation Radar 1 BASS TILT Fire Control System 1 HIGH POLE-B-IFF Antenna 1 SQUARE HEAD-IFF Antenna 1 CAGE STALK Antenna (FT) 2 Decoy Missile Launchers
--------------	---

---

Chart 2. Polish Navy TARANTUL-I Units

Name	Pennant Number	Commissioned
GORNIK	434	28 December 1983
HUTNIK	435	31 March 1984
STOCZNIOWIEC	436	1985

Chart 3. GDR NAVY TARANTUL-I Units

Name	Pennant Number	Delivery to GDR
ALBIN KOEBIS	771	24 September 1984
Undetermined	772	2 April 1985
Undetermined	773	Summer 1985

9273/9599  
 CSO: 2300/110

MILITARY

BULGARIA

REVOLUTIONARY VIGILANCE, PRESERVATION OF MILITARY SECRETS URGED

Sofia NARODNA ARMIYA in Bulgarian 14 Nov 85 p 2

[Article by Col Stoyan Kunchev, Bulgarian People's Republic Supreme Court justice: "Preservation of Military and State Secrets"]

[Text] Countries inimical to others have always tried to learn the military secrets of the opposite side. The history of espionage dates from profound antiquity, from the time of the first armed clashes between hostile tribes. The number of men capable of fighting, their armaments and tactics, the individual qualities of military commanders and other types of information have always been enemy targets.

The current complex international situation and the efforts of imperialist forces to attain military superiority over the USSR and the socialist community have aggravated the secret war to an incredible extent. The experience of the special state bodies and the courts indicates that in recent years imperialist intelligence services have shown increased interest in our country and have energized the activities of their agents, for which reason the problem of preserving state and military secrets has become exceptionally relevant. All citizens, military personnel in particular, should be aware of the type of information, facts and targets considered state and military secret, the laws which govern this problem and the liability for making such information public.

The most general definition of the concept of state secret is provided in Article 104, Paragraph 3, of the Penal Code of the Bulgarian People's Republic. It reads as follows: "State secret means facts, information and targets of military, political, economic or other nature, the knowledge of which by another country or foreign organization could harm the interests of the people's republic and, particularly, its security. The list of facts, information and objects considered state secret is drafted by the Council of Ministers." Such a list was approved with Decree No 30 of the Council of Ministers, dated 4 July 1980.

Let us point out in this connection that in addition to state secrets, our legislation also recognizes the so-called official secrets. Article 360 of the Penal Code, stipulates that this applies to "information of military,

economic or other nature not considered state secret but the publication of which is forbidden by law, order or any other administrative ruling."

However detailed such a list may be, it nevertheless contains general data only. Arguments and hesitations in resolving specific cases appear in the practical work of commanders and courts.

We are familiar with cases of revealing state and military secrets indirectly. In a letter to his parents, a soldier complained that in the course of his training he had been asked to wash 350 food trays. It was the court's decision that he had thus revealed the number of participants in the exercise. Point 4 of the list categorically states: "Information concerning exercises held." This would apply to a case in which the cook in a unit would tell his friends the number of daily food rations prepared.

Some believe that revealing a state secret should entail significantly damaging consequences to the interest of our country. Such is not the case. A curious and mistrustful wife may force her officer husband to tell her the place where the forthcoming exercise will take place and when he will be back. Concerned parents may interrogate in detail their son on life in his unit. A soldier may reveal that there is an influenza epidemic in his unit. The family of a military serviceman may gossip about a worsening of relations between the commanding officer and his deputy. People involved in a court martial may inform their colleagues on thefts, appropriations and misappropriations. In order to make himself look good, a young seaman may inform his girlfriend about armaments and the firepower of his ship. Also such seemingly insignificant types of information provide an idea of the combat readiness, the moral and political condition of the military unit, the itinerary of an exercise, or extraordinary accidents in the Bulgarian People's Army. Yet all of this is included in the list as strict state secret. Such thoughtless and lightheaded actions may be prosecutable offences.

The worsened international situation and the attempts of imperialism demand of all of us to enhance our revolutionary vigilance in order to remain true to the oath of "strictly preserve military and state secrets!"

5003

CSO: 2200/46

MILITARY

BULGARIA

EDITORIAL CALLS FOR STRICTER DISCIPLINE

Sofia NARODNA ARMIYA in Bulgarian 19 Nov 85 p 1

[Editorial: "Discipline in Everything and Everywhere!"]

[Text] Military discipline is a key problem in the struggle for the overall implementation of combat and political training assignments. "High and conscious discipline," points out Comrade Todor Zhivkov, "discipline in everything and everywhere and conscientious fulfillment of obligations by everyone, regardless of whether he is a worker, specialist or manager, are prerequisites without which we cannot take even a single step forward in the struggle for high quality." The soldiers in our army accept these words with the clear awareness that without discipline no significant successes can be achieved in maintaining combat readiness and in combat and political training.

Most essentially, discipline means the accurate and absolute observance by all military personnel of orders as stipulated by laws and military regulations; it imbues all activities related to personnel training and upbringing, maintenance and utilization of armaments and equipment, and comprehensive security.

A characteristic feature of discipline in our army is its clearly manifested conscious nature, which the personnel prove through their accurate understanding of party policy and the targets and tasks of military service. Another feature of discipline in the BNA [Bulgarian People's Army] is its collective nature distinguished by reciprocal exigency among soldiers and constant concern for the affairs and needs of the entire collective.

Discipline in the units where officers Tonev, Vladimirov, Dzhurov, Nikolov, Kunev, Naydenov and others serve, rests on the firm foundations of regulations and orders and the standards of our socialist morality. Commanders, political workers, staff officers and other specialists in these combat collectives show constant concern for the comprehensive development of firm ideological convictions, high political vigilance and infinite loyalty on the part of the personnel to the BCP and for strengthening the organization of their work, thus ensuring the prompt and high quality implementation of assignments.

Many officers are distinguished by high discipline and organization in their daily practical work. They are able to concentrate on the main features which

determine the training of the troops. They show strict exigency toward the actions of their subordinates. They properly understand the educational functions of discipline which shapes the young and still unformed characters of the soldiers and which teaches them collectivism, organization and endurance.

However, some commanders, staffs and political organs do not take decisive measures or engage in a constant and uncompromising struggle for the strict observance of regulations, instructions and orders governing army life. Specific and purposeful work must be done in exposing and eliminating prerequisites for discipline violations.

The very content of military discipline has been considerably broadened and, consequently, so has its possibility of influencing the combat readiness of the troops. Ensuring uninterrupted control of military units demands particularly high level of organization on the part of officers in command.

The current stage in the development of the BNA involves the use of scientific and technical achievements and mastery of new equipment and armaments. This calls for changes in the way of thinking and acting and of work style and methods, as well as the adoption of a new approach to problems of discipline. The need to repel a sudden attack and the immediate implementation of combat assignments creates the discipline of combat guard duty. This demands great moral and physical stress on the part of the troops.

The growing importance of organization and discipline under contemporary conditions is also the result of a number of sociopolitical and general state factors. As Army General Dobri Dzhurov, minister of national defense, emphasizes, "organization and discipline are interrelated; they are reciprocally supporting social processes which do not exist for their own sake but have always been forms of progress toward specific objectives. To us such objectives are building a communist society and ensuring its defense."

The BNA troops are fully resolved to study more profoundly and promptly resolve the major and difficult problems stemming from the resolutions of the 12th party congress, the National Party Conference, and the BCP Central Committee plenums. They demand the revolutionary restructuring of thoughts and behavior and cadre work style and methods; they call for a break with manifestations of tolerance and liberalism toward violators of regulations, statutes, discipline and socialist legality. This will create favorable prerequisites for the command-organizational and party-political work and development of the socialist competition over the next few months to take place under the inspiring slogan of "High Accomplishments in Combat and Political Training and Strengthening Discipline and Maintaining a State of Permanent High Combat Readiness in Honor of the 13th BCP Congress and the 30th Anniversary of the April BCP Central Committee Plenum.

5003  
CSO: 2200/46

MILITARY

GERMAN DEMOCRATIC REPUBLIC

#### NEW NAVY TORPEDO BOATS DESCRIBED

East Berlin VOLKSARMEE in German No 39, 1985 (signed to press 23 Sep 85) p 8

[Article by Commander H. Mehl: "The Navy's Small Torpedo Boats"]

[Text] On 4 November 1985 it will have been 25 years since the sea combat forces of the GDR received the honorable name "People's Navy." At that time the building up of attack forces, along with the creation and development of security forces, had come to have special importance. In face of continual threats to socialist Baltic-coast states by aggressive elements of the NATO fleets, which openly declared the Baltic an "ideal runway," the Navy's attack forces were equipped to be able to effectively counter imperialist seaborne aggression. These forces included gun platforms as well as various classes of torpedo boats, and later also rocket-platform ships.

Along with the two-tube project-183 mosquito boats made available beginning in 1957 by the Soviet Union, the People's Navy received light fast torpedo boats (LFT boats) from the GDR's shipyards beginning in September 1962. These boats were developed in about 4 years by the staff of the then existing Wolgast Institute for Naval Architecture in close cooperation with the participating shipyards. Special consideration was given, in this, to the geographical conditions in the southwestern Baltic. Conspicuous characteristics of this development were the boats' low silhouette (which assures delayed spotting by enemy radar stations), as well as the high top speeds of around 50 knots (50 sea-miles per hour, or 92 kilometers per hour), necessary for surprise.

#### With Modified Tank Motors

Several experimental vessels were built and tested, among them a hydrofoil LFT boat of project 81 and a prefabricated boat of plastic materials from Project Seagull. Thereupon began the production of 30 LFT boats of project 63 300, under the class-name "Iltis," in the Wolgast Peene Yards National Plant. They were put in service serially. This model's hull was made of seawater-resistant light metal by the all-welded method. Two Soviet M50 F3 882-kw V-12 engines served as propulsion. This four-phase diesel motor, with which the bigger project-183 torpedo boats were also equipped, is an enlarged version of the proven Soviet W-2 tank motor, which is equipped with flanged rotary gearing for naval installation. These LFT boats received two launching tubes for 533-mm torpedos as their main armament. Compressed air permits launching of the torpedos from the tubes mounted diagonally in the hull. The torpedos clear the

tubes opposite to the boats' heading, but with the warheads in the direction of launch. The three-man crew's space was recessed into the bow and covered above by a cockpit. The boats' radio and radar equipment permitted deployment in all visibility conditions.

#### A New Version

A second version of the LFT boat was delivered to the People's Navy starting in 1964. The boat, which was developed under the project-number 68 200, was built by the Berlin Yacht Yards National Plant and was put in service, to the number of 15 units, up to 1968. The main dimensions of this LFT-boat model were modestly enlarged, but the hull was built entirely of mahogany or of multiply-bonded plywood. A novel solution was the installation of a hollow rubber strip below the waterline on either side, whereby the leaking common in wooden boats was reduced to a great extent. Here also, two M50 F3 engines with remote control from the bridge served as propulsion. These boats received three side-by-side 533-mm torpedo tubes as main armament, also with stern launch against the boats' heading. Minelaying equipment could be temporarily rigged in place of the two outboard tubes on this model. With this, the boats were also usable for laying command-fired mines. In a third arrangement, seats could be mounted instead of the torpedo tubes, whereupon the boats were also employable as fast transport vessels for landing forces or commandos. Upon reaching their service limits, both classes were retired from service according to schedule, through 1977. A Berlin 68 200 boat was put on exhibit in the GDR Army Museum in Dresden, and a Wolgast 63 300 boat in the Naval Architecture Museum in Rostock-Schmarl as testimony to the performance of the GDR shipyard industry.

#### The Follow-On Model

As follow-on generation, a new torpedo boat was developed by GDR experts and built in co-production by the Rechlin Shipyards National Plant and the Wolgast Peene Yards National Plant. The hull of this vessel, which was classified as a "Small Torpedo Boat" (ST boat), was also built of a seawater-resistant light-metal alloy. The main dimensions, which were enlarged over those of the earlier LFT boats, yielded a further increase in combat effectiveness, as well as considerably improved seaworthiness under difficult service conditions (sea, wind). Besides being equipped with two 533-mm torpedo tubes, the boats could be armed with a 23-mm twin gun of the proven Soviet ZSU-23/2 model. In addition, the boats are equipped with minelaying apparatus, so that their employment as fast minelayers is possible. Three Soviet M50 diesels, subtypes F4 through F7, serve as the main engines, with a total output of 2,646 kw. The boats are equipped with modern electronic location and communication systems, whereby they are usable under any visibility conditions and at any time of day or night. The experimental boat was ready for presentation to the public as early as the fleet review in Rostock on the occasion of the 25th anniversary of the GDR. Since then, the ST boats and their crews have repeatedly proven themselves in maneuvers and exercises of the allied Baltic fleets. The Bronze Combat Award for Services to People and Fatherland was awarded in 1981 to the "Karl Beier" unit, which is equipped with these boats, for excellent results in political and combat training.

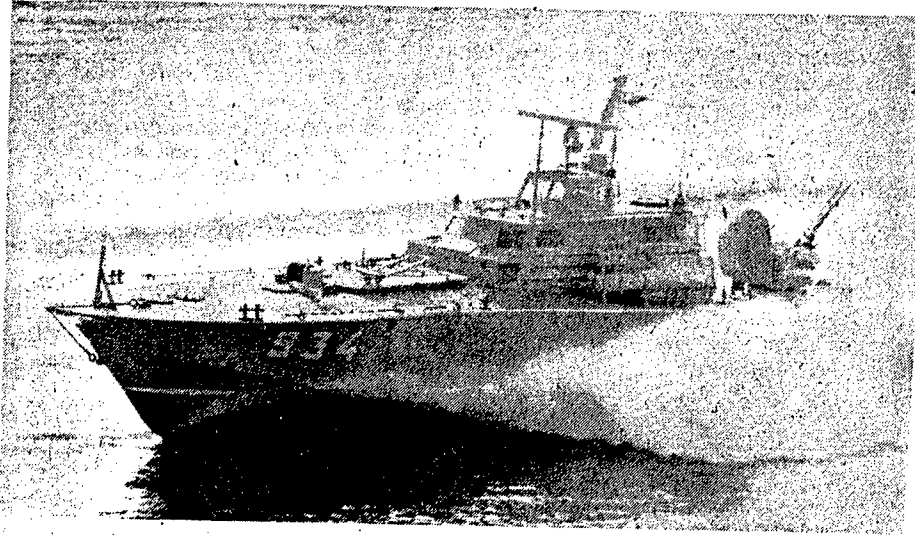

**KTS-Boot**

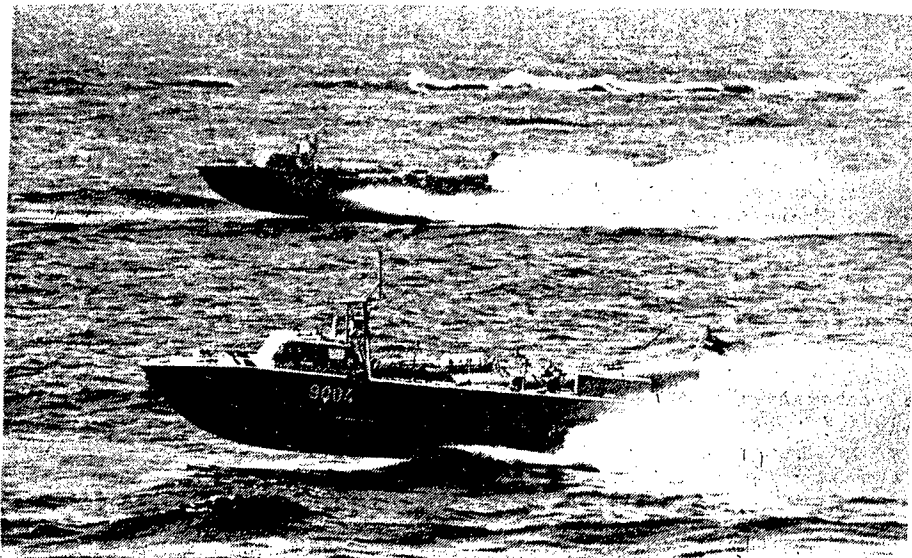

**LTS-Boote des Projektes „63 300“**

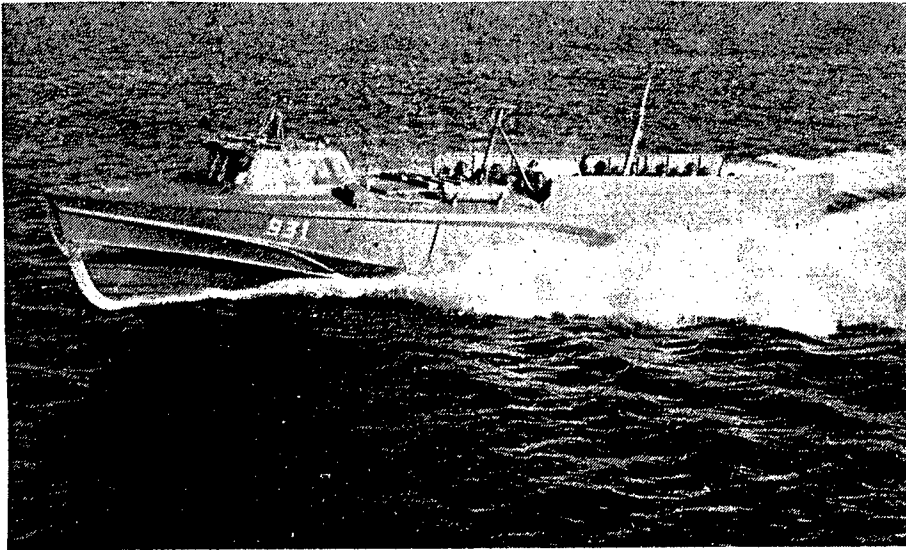

LTS-Boot Projekt „68 200“ in Transportvariante

13070/12766  
CSO: 2300/62

MILITARY

GERMAN DEMOCRATIC REPUBLIC

### SHIP-MOUNTED ANTI-AIRCRAFT WEAPONS DESCRIBED

East Berlin AR-ARMEERUNDSCHAU in German No 11, Nov 85 pp 46-49

[Article by Maj Ulrich Fink: "Aerial Target Approaching"]

[Text] NATO ships and aircraft have for many years engaged in war-like exercises involving operational use of a great variety of aerial weapons in and above the Baltic, at times only 10 to 15 sea miles away from our sea border. Obviously these provocative maneuvers are not hidden from the three allied socialist Baltic fleets. The sailors, petty officers and officers of the USSR Baltic Fleet, the navy of the People's Republic of Poland and our own People's Navy are well aware of the great danger engendered by NATO's preparations for war in the Baltic area. Thus they are aware also of the growing importance of defense against aircraft, combat helicopters and antiship missiles. Our three fleets give their full attention to this by virtue of their materiel and training, since their primary task is to be fully proficient in the air defense field through great alertness and complete familiarity with all reconnaissance, control and combat materiel. For this purpose our ships are equipped with proven artillery systems and modern missiles.

Among them, the 2-M-3 110 PM 25 mm twin antiaircraft gun has for some time been part of the armament of many ships of the socialist defense coalition. The automatic gun with a movable barrel is built as a recoil-operated weapon and can theoretically fire 270 to 300 rounds per minute. Upon leaving the barrel, the initial velocity of the munition is 900 meters/sec. The two-man crew can aim the gun hydraulically with a control column or with the handwheels of the lateral and vertical aiming device. However, one of the most modern ship artillery systems for air defense, which is aboard almost all new combat ships, is the automatic 30 mm gun. It works on the revolver principle. Its six barrels form a barrel drum. This automatic weapon, mounted inside a small, 360° revolving turret, is operated entirely by radar. Due to its high aiming speed and rate of fire it is especially suitable for defense against antiship missiles.

However, the small and medium size caliber guns on shipboard are suitable not only for defense against aerial targets. A number of them are designed for use as multipurpose weapons. This means that they are equally capable of attacking combat speed boats which are within their effective ranges for only a short time. The calibers of these single or multiple barrel guns ranges from 30 to 76 millimeters.

However, the heavy-caliber antiaircraft weapons which were in use during World War II have since been replaced by ship-to-air missiles. It became necessary to deploy antiaircraft missiles aboard ships since in the post-war period there has been an enormous increase in air force combat options due to the use of jet aircraft, radar technology and newly developed missiles, bombs and torpedoes.

Ship-based air defense missiles are distinguished from conventional artillery by much greater effective range, great hit probability and destructive power. This applies mostly to two stage missiles which are 4.50 to 7.70 meters in length and whose diameter ranges from 50 to 60 cm. Launching devices are automatically aimed laterally and vertically. Loading is done automatically also. The missiles are brought from the missile storage space by an elevator direct to the launching device and placed upon the vertical launch rail.

However, the most important prerequisite for effective operation of antiaircraft missiles are the fire control systems, which is the case also for the barrel artillery. In the final analysis, the control systems and their sailor specialist operators are the determining factor of whether an approaching missile will reach its target or whether it will be intercepted and destroyed beforehand. The fire control systems thus must locate and track the target in time, determine the target coordinates and transmit these data to the launch ramps. For guided missiles, a support station, additional computers and a control station are added.

The one-man Strela anti-aircraft missile requires nowhere near that much support. It is found in quadruple mounts aboard modern coastguard ships. They are mounted at the port and starboard sides behind the bridge on rotating disks and can thus be aimed vertically as well as horizontally by the operator.

The missiles are launched individually in sequence. However, the operator needs to aim only one of the missiles which are equipped with an infrared search head. When the search head detects the heat source, i.e., the engine of the target to be attacked, the operator hears a claxon sound and sees a red lamp being illuminated. He can then launch the missile. It finds its way to the target independently, reaches and destroys it with a high degree of probability. With the Strela on board, the coastguard ships have an additional effective weapon against low-flying fighter bombers and cruise missiles.

To detect and attack the latter is generally a very complex task. They fly at low altitudes at speeds ranging from 800 to 1200 km/hour and have ranges from 80 to 200 km. However, the fleets of the socialist defense coalitions have an air defense system which is echeloned as to range and altitude. It provides close cooperation between the various locating and fire control devices, air defense missiles of varying range, light and medium antiaircraft guns, fighter aircraft and electronic warfare systems for the protection of our borders.

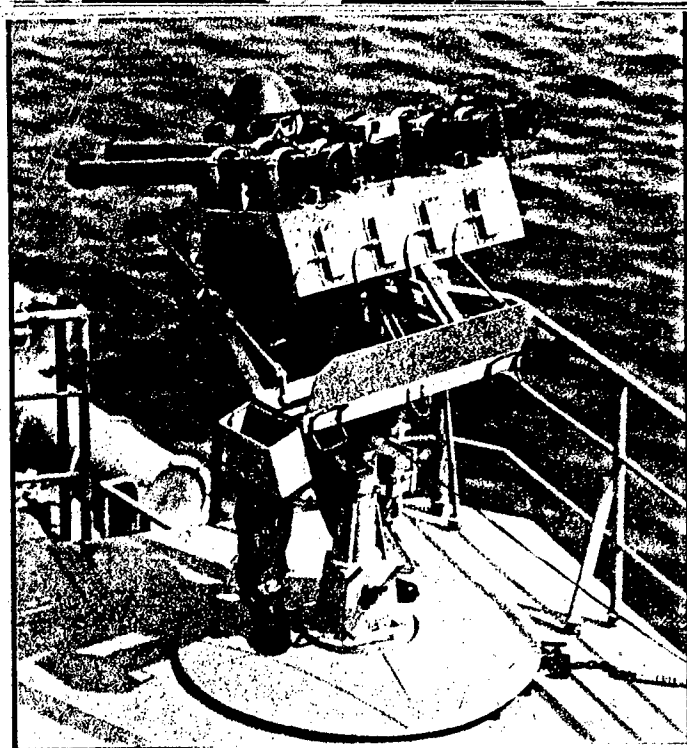

Quadruple launcher for the Strela air defense missile

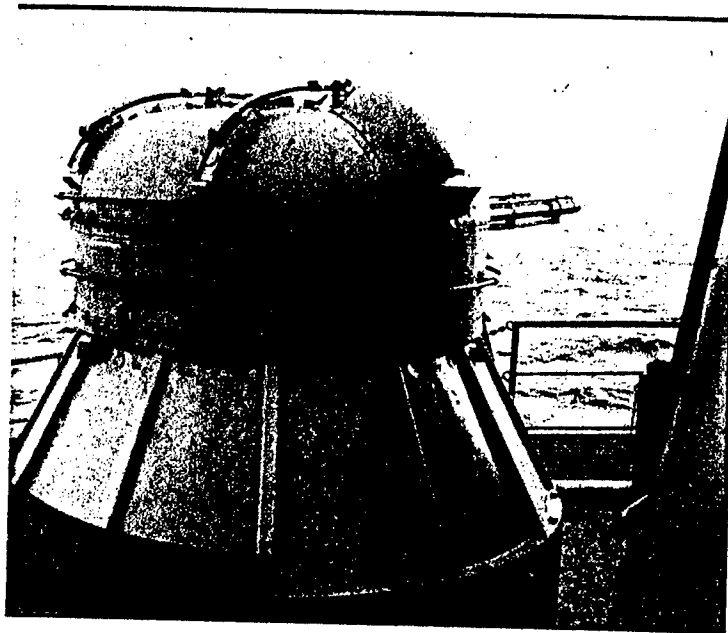

Radar-operated 30 mm multipurpose weapon in twin turret

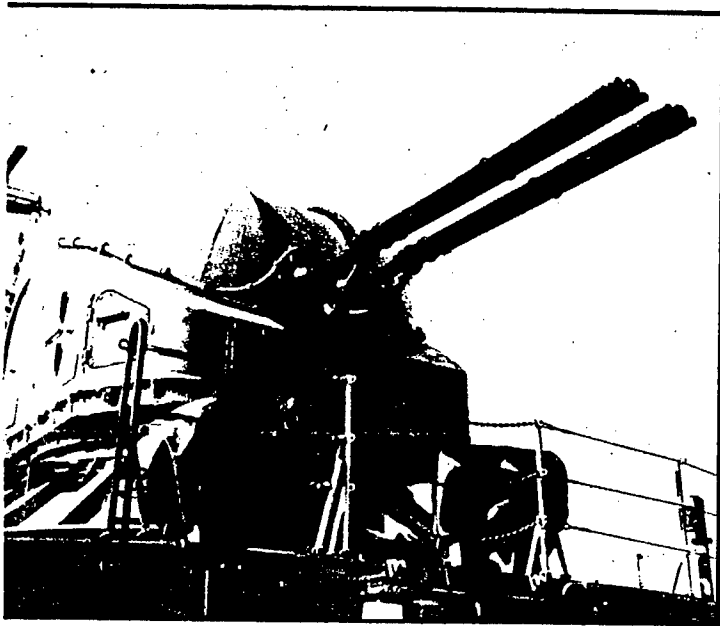

57 mm multipurpose weapon.

9273/7051

CSO: 2300/82

MILITARY

GERMAN DEMOCRATIC REPUBLIC

#### DEVELOPMENTS IN FLIGHT NAVIGATION SYSTEMS DISCUSSED

East Berlin MILITAERTECHNIK in German No 5, 1985 (signed to press 10 Jul 85)  
pp 266-267

[Article by Colonel G. Lehmann: "Flight Navigation Complexes Raise Accuracy and Safety of Flight"]

[Text] The navigational equipment of an aircraft (helicopter) enables the crew to fly their aircraft and to get to the assigned place at the assigned time by the intended flight path.

Flight navigation must be available with certainty at all times: day and night, under any meteorological conditions, during combat operations, under the effects of enemy jamming, during intermittent or complete failure of ground navigational facilities, or when outside their effective range.

#### 1. Scope and Use of Navigational Equipment

Navigational equipment comprises navigational data generators and computational equipment.

Navigational data generators are devices that by use of various physical effects provide primary data autonomously or non-autonomously. Primary data reflect selected navigational flight elements, such as position coordinates, course, speed, drift angle, altitude, etc. They are determined with the help of air instruments (aerometric speed and altitude indicators, temperature indicator), of magnetic-field indicators (magnetic compass, induction compass), of gyroscopic devices (semigyroscopic compass, angle and angular-velocity indicators), of acceleration indicators (inertial navigation equipment, inertial devices), and of radionavigational devices (radio altimeter, radio compass, short- and long-range radionavigational equipment, Doppler navigators).

From the primary data the computational equipment works out all the navigational parameters essential for piloting the aircraft, carry out comparisons of planned vs actual values, and prepare instructions for maneuvering the aircraft. These can be peripheral computers (computational circuits integrated into the navigational instruments) or central onboard computers.

As a rule, several navigational instruments measure the same navigational parameter in physically differing ways. Examples are aerometric and radio altimeters,

aerometric airspeed indicators and Doppler navigation devices, as well as magnetic compasses and gyroscopic compasses (course systems), etc.

It is in the first instance up to the crew to make preponderant use of those systems that promise the highest accuracy of measurement under the given flight conditions. They also monitor the trustworthiness of the measured values by comparing the readings of several devices. If they rely on the readings of the relatively precise radionavigational equipment, accidental errors and temporary interruptions (due to irregular wave propagation, interference, jamming) must be included in their calculations.

If the crew is working preponderantly with aerometric and gyroscopic devices, their relatively large systemic measurement errors and drift errors will lead to unacceptably large deviations in the fulfillment of assigned combat missions. The comparison of the measurements of various instruments is made more difficult by differing coordinate systems (according to the physics of the measurement apparatus: ground-based, aircraft-based, space-based, Cartesian, spherical or polar coordinates), which necessitate conversions (coordinate transformations).

The rapidly growing demands on the combat characteristics of modern combat aircraft, and the introduction of new weapon systems and of hitherto unknown tactical procedures require that aircrews be relieved from non-substantive activities, in navigation as elsewhere. They have led to the creation of automated flight navigation complexes.

## 2. Flight Navigation Complex

It unifies all the important navigational instruments under the control of a central onboard computer (navigational computer) or of peripheral computers. This allows switching to automated solution of standard navigational tasks, for example, for cruising, target approach, return to base, landing approaches and repeat approaches.

It can be set up as a self-contained onboard complex or as a component of a superordinate onboard complex (targeting-navigational complex, navigational-maneuvering complex). A flight navigation complex must store all the necessary navigational data for the duration of the combat mission (target coordinates, coordinates of bearings for cruising, airbase coordinates, main and alternate landing approaches, the coordinates, service frequencies and channels of the ground [as published: "onboard"] navigational facilities, etc.). The data mentioned here will be selected during flight planning, and fed in before take-off, and can, depending on aircraft model, be updated and refined during the combat mission.

The flight navigation complex must further determine at all points the exact position coordinates of the aircraft from the primary data of the navigational instruments.

The navigational complex must be able to calculate the most important navigational and maneuvering parameters for piloting the aircraft (planned course, planned altitude, distance to destination or time to destination or to turning point, etc.) and to formulate correction values by planned-vs-actual comparison.

It should be able to make logical decisions on the choice of the closest ground aids to navigation and to make automated changes in mode of operation (cruise, prelanding maneuvers, landing approach, repeat approach, etc.). Further, it must be possible to take the calculated data from it for visual representation on instruments and displays as well as for maneuver commands.

Finally, the flight navigation complex must be so designed that the reliability of the entire complex can be monitored, the crew be warned of the failure of component equipment, and the solution of combat problems within acceptable tolerances be assured even with the failure of navigational instruments or in cases of forced landing.

### 3. Structure and Operation of the Navigation Complex

These are determined by the combat missions that are to be fulfilled with the aircraft model in question, when used against air, ground or sea targets, and naturally by the technological state of the art. Already today, high-performance onboard computers, with their high calculating speed and large storage capacity, allow the demands made on the navigation complex of a multimission combat aircraft to be fulfilled quite well.

Such demands are, for example: accuracy of measurement, security from interference and reliability of the complex as a whole must be higher than that of the individual navigational instruments and components. This is achieved through optimal signal processing (filtering) of the primary data by analog or digital filters.

Further, the navigation complex must fundamentally work autonomously. It is able to rely exclusively on the primary data supplied by the onboard autonomous navigational instruments. And this despite the relatively large errors of measurement (around 5 percent) in aerometric instruments and the cumulative drift and integration errors of gyroscopic and inertial navigation systems.

Non-autonomous radionavigational systems, with errors of measurement of under 0.5 percent, are brought into play for correction of measurement and calculation errors only when a secure radio link with the outside station (ground navigational facility) exists. This link can, however, be interrupted due to enemy influences, by reason of insufficient effective range (especially on flights of moderate altitude), or on tactical grounds (masking).

All inputs and outputs of navigational data must be in terms of a coordinate system appropriate to the given stage of flight, which allows the pilot favorable working conditions, spatial representation, and ability to monitor the agreement between indicator readings and actual flight situation. So, for example, cruising and target approach are often carried out with conditional coordinate systems (so-called orthodromic coordinates), landing maneuvers with a ground-based coordinate system, and instrument-landing approaches with ground-based coordinates referred to prescribed course and glide paths.

When maneuver commands calculated by the navigation complex are being switched through to the autopilot (automated flight), the pilot must be able to assume manual control of the aircraft at any time for carrying out non-preprogrammed

flight patterns (upon contact with the enemy, entry into aerial combat, escape maneuvers, etc.). Uninfluenced by this, the navigation complex must thereupon permit the continuation of the originally planned combat mission.

#### 4. Filtering in the Navigation Complex

The exit signal of a navigational instrument contains both the true measured value of the information signal and also systematic errors of measurement and random error (interference, random fluctuations of the carrier). Although this mixture of signals can be thought of as the sum of its individual components, these latter cannot be isolated from one another in the exit signal.

The exit signals of various navigational instruments which measure the same navigational parameter in physically differing ways (e.g., speed measured by aerometric airspeed indicator and by Doppler navigator) differ in the form and bandwidth of their amplitude spectra.

The desired information-bearing signal being sought displays an extremely low-frequency character. Its bandwidth amounts to a few tenths of a Hertz (the aircraft represents a large mass, whose motion and orientation in space can only slowly be altered; abrupt changes in speed and altitude are impossible). The spectra of the random errors, however, display great differences.

Random fluctuations of the exit signals of aerometric, magnetic or inertial devices result from inhomogeneities of the atmosphere, from turbulence, from swings in air temperature and therewith also in air pressure, from interference from the earth's magnetic field, from bearing friction, etc. They disperse slowly, with cutoff frequencies (bandwidths) of up to several Hertz.

Radionavigational equipment, on the contrary, reaches interference bandwidths of some 10 to 100 Hertz. This is explained both by the influence of wide-band outside interference sources and also by quick fluctuations in the reception signal within the aircraft due to interference phenomena which can at times even interrupt reception altogether.

By insertion of low-pass and high-pass filters in the signal paths and immediate summation of the filtered exit signals of varied navigational instruments, it can be brought to pass that the desired service signal is in the final analysis transmitted undistorted, while the interference is for its part sharply reduced in amplitude and bandwidth. This is identical to an improvement in the relationship of signal energy to interference energy in the complex as a whole, and leads to a reduction of the overall error of measurement as compared to the individual errors of measurement.

Such filters are created in analog computers by means of integrators or in the form of electromechanical series.

The method just described is, however, of little effectiveness if the exit-signal spectra of individual navigational instruments display no marked differences or when only one instrument is available. In this case, probability-theoretical considerations lead to usable results.

Probability theory supplies solution methods for estimation problems in the determination of expected value and random-variable dispersion in a stochastic process (the exit signal of a navigational instrument represents such a stochastic or random process).

Starting from the assumed-known (statistically derived) a priori distribution of probability densities of the navigational parameters in question and of the interference signals, the conditioned a posteriori probability-density distribution ("as measured") is determined with the help of a mathematical model of the aircraft and the navigation system. The calculated result is corrected by the actual exit signal of the navigational instrument with reference to the intensity of the measurement interference.

Such an optimal filter (minimal-variance filter, Kalman filter, Kalman-Bucy filter) is similar to a control circuit with non-stationary parameters, and is made possible in real-time operations by means of fast computers. Its broad application is primarily reserved for modern generations of combat aircraft.

A further increase in accuracy of measurement and reliability in flight navigation complexes is presently on the horizon: satellite navigation is becoming possible, which permits passive position-finding (ranging simply by reception of satellite signals on a standard-time basis). Satellite navigation devices can at least partially replace traditional ground navigational facilities and can be used for periodic error adjustment in the complex.

Flight navigation complexes link various pieces of equipment and devices needed by the pilot. They are based on advanced signal-processing methods and increase navigation accuracy and navigation security considerably.

Understanding the interior relationships in flight navigation complexes is an essential prerequisite to their optimal use, and must be required of all members of the engineering and technical staff.

Figure 1: Structure of a Flight Navigation Complex (Solid lines: main components; dashed lines: components with which the complex operates)

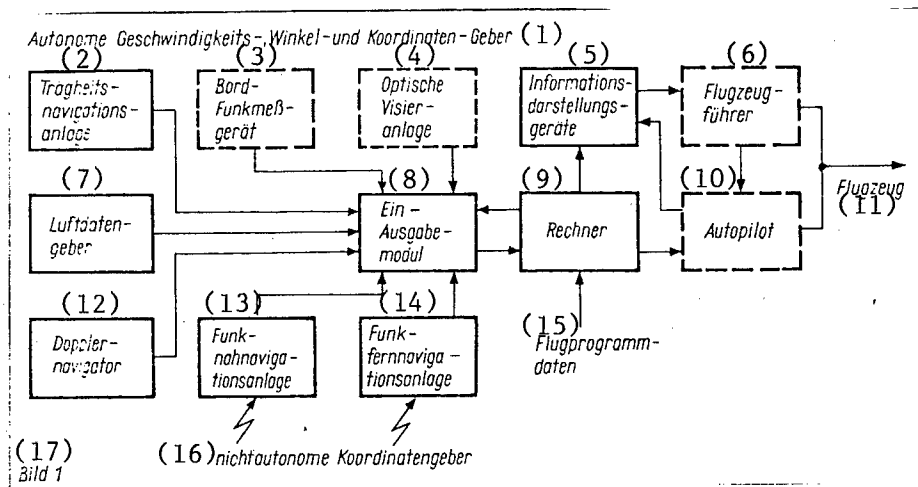

Key:

1. Autonomous Speed, Angle and Coordinates Instruments
2. Inertial navigation system
3. Onboard radar apparatus
4. Optical sighting system
5. Information display devices
6. Pilot
7. Aerometric instruments
8. Input/Output module
9. Computer
10. Autopilot
11. Aircraft
12. Doppler navigator
13. Short-range radionavigational system
14. Long-range radionavigational system
15. Flight-program data
16. Non-autonomous coordinate sources
17. Figure 1

13070/12766  
CSO: 2300/5

MILITARY

POLAND

## UTILIZATION OF AIR DEFENSE ROCKET FORCES WITHIN DEFENSE SYSTEM

Warsaw PRZEGLAD WOJSK LOTNICZYCH I WOJSK OBRONY POWIETRZNEJ KRAJU in Polish No 12,  
Dec 85 pp 19-21

[Article by Col Dr Tadeusz Kropiowski: "Principles for the Deployment of Air Defense Rocket Forces"]

[Text] Like other defense forces operating within a unified air defense system, rocket air defense forces are used in accordance with specific principles. I think it might be useful to recall for readers at the least the most important principles for the deployment of air defense rocket forces, especially inasmuch as the principles of the use of aircraft have already been presented in the pages of this publication.

Rocket forces deployment principles, in the sense of generalized conclusions and recommendations concerning the preparations for and conduct of combat operations, have taken shape as these forces have developed, as their combat capabilities have increased, and also as the result of the gathering of experience and the discovery of the basic relationships and interdependencies which arise during combat at the time that the enemy in the air is engaged. Of particular importance has been the experience of local wars in which antiaircraft rocket forces and means have been used, especially combat experience in Vietnam and the Near East.

Despite their short history, rocket forces have developed significantly in the technical and organizational realm, but in order to insure effective rocket air defense of the country's areas and installations, even the better and better rocket air defense measures do not suffice. Still essential is their proper use. This issue is important too because usually the strength of these forces is less than one might think given the needs dictated by the threat of air strikes and the possibilities afforded by modern weapons of air attack from the potential enemy.

One of the basic principles for the deployment of rocket forces is a high level of readiness to carry out air defense combat tasks. The enemy always tries to use the element of surprise, and it is always a very short time that the air defense rocket forces have between the moment they first receive information about the air targets and the moment of opening fire and destroying those targets. Unfortunately this time is getting shorter and shorter, because of the speed of the enemy's air attacks, low-level flight, and limitations in the scope of air target radar reflection (making the distances shorter from where the air targets are de-

tected for the first time). Rocket forces units should be in such a state of readiness that they can begin combat operations in time and attack the approaching enemy while they are some distance away.

The execution of this principle is insured through development (grouping) of rocket forces in the field, by preparing them in a comprehensive way for combat operations, and by having rocket forces continually on duty.

The next principle for deployment of rocket forces is for them to destroy the air attack agents en route to the installations being protected before they reach the target zone.

To provide for the defense of installations, rocket forces should engage (destroy) enemy air attack agents before they reach the point from which they can harm the installations being defended. This is fully understandable, particularly when we take into account operations involving nuclear weapons, but it should be mentioned that it is becoming increasingly difficult to accomplish this, despite the fact that rocket firing range has been extended, because the problem is that the range from which enemy air attack agents can be a direct threat to the installations being defended has been increased.

Formerly the distance from which the target installation could be hit was rather small (using undirected aerodynamic bombs the bombing distance was a few kilometers up to a dozen and some kilometers), but now this distance can be several dozen kilometers or more. It is therefore necessary to engage air attack agents of the enemy both at great distances from the installations being defended and close to them, but always before they reach the point where they can strike the target. This is why the firing zone (airspace within the boundaries of which the rocket forces can engage the air targets) should be beyond the strike execution line.

We can see that this requirement is met, for example, by where we place the rocket forces weapons and men with respect to the installations being defended and also by using rockets of various range (distant, intermediate, and near) to protect these installations.

Within our country there are many installations which could be air targets for the enemy. Among these installations are those of great importance as well as those of lesser significance. Military experience and analyses of rocket force deployment possibilities and principles show that the airborne enemy will attempt to destroy the most important installations and focus the attack on these. The next principle for the deployment of rocket forces, therefore, is to focus defense efforts (before the air strike) on the most important installations and areas of the country and the most important directions.

Despite the rise in the overall potential of rocket forces and the firing ranges of modern rockets, it is difficult to give equal rocket coverage to the whole area at the present stage, but this does not seem absolutely necessary given the principle of enemy air force deployment.

A logical conclusion follows that the defense should be the greatest for the most important installations (areas), especially in the major directions of enemy air attack. In order to provide for the proper distribution of rocket forces concentrated to defend a given installation (area) and enemy attack agents, a given quantity (and type) of rocket equipment is placed accordingly and a multilayered fire system is provided to insure the destruction of air targets regardless of flight level, target density, radar interference, and so on.

The next principle pertains to the creation of so-called "mixed rocket force groups" in order to use various rocket types for the defense of installations (areas).

The airborne enemy employs various agents and weapons for the strike and different sorts of aircraft. When we consider the variety of aircraft and the weapons they carry, the radar interference devices and their methods of operation, it is easy to understand that it is not possible to insure a high level of rocket air defense effectiveness by basing that defense on a single type of rocket installation. The complex use of various sorts of rocket types including a variety of tactical-technical capabilities and properties provides for greater effectiveness of the rocket defense system and at the same time provides for a greater degree of certainty that the rocket forces will not be overcome by enemy air strikes.

In order to execute this principle, it is necessary among other things to use various types of rockets in the rocket force groups and to insure that their capabilities are exploited to the maximum.

The next principle is to focus rocket forces command (direction of fire), while at the same time providing for the rocket subunits to engage in combat independently.

One of the factors that determines the number of air targets that the rocket forces destroy is what is called the command coefficient: the greater it is the greater the number of air targets destroyed. This coefficient is usually greater when command is centralized, but in certain situations, such as when air targets are detected late, it is more effective for the direction of fire to be decentralized during combat. This is the reason why the rocket forces have automated command systems making it possible to direct the fire of many rocket subunits centrally while at the same time equipping the subunits with various means (such as reconnaissance agents) allowing for the independent conduct of combat operations, based on autonomous detection sources using command decisions issued by personnel at lower levels.

Cooperation between rocket forces and other branches of air defense, especially fighter planes and radar forces, is the next principle in the deployment of rocket forces, because we do not yet have a single universal means to insure that all realms of this defense can be accomplished under the various sorts of conditions. For example, air defense forces have great fire power but restricted maneuvering capacity, while fighter aviation, owing to its great maneuvering capacity, is an important factor in focusing the efforts of air defense forces in the directions of air attack and the creation of the necessary combat force relationship vis-a-vis the enemy.

10790

CSO: 2600/204

MILITARY

POLAND

## ATTITUDES TOWARD MILITARY SERVICE SURVEYED

### Positive Attitudes

Warsaw WOJSKO LUDOWE in Polish No 10, Oct 85 pp 41-42

[Article by Lt Col Dr Jerzy Wisniewski: "When the Attitude Toward the Service Becomes Positive"]

[Text] A positive attitude toward military service manifests itself among servicemen, as a rule, in the form of conscious self-subordination to disciplinary rules, military regulations, norms of collective life and as a feeling of responsibility, devotion and self-sacrifice in everyday service. In connection with the above it would be ideal for young draftees to have a developed positive attitude toward military service. In reality, however, this is not always so. This is confirmed by the studies I carried out during the years 1982-1983. And although some time has elapsed since then, it seems to me that both the findings of these studies and the conclusions and practical indications ensuing from them have not lost their topicality.

The need for studies of the attitudes of youth toward military service is prompted by the fact that, during the martial-law era as well as at present, the variability of attitudes toward military service is markedly influenced by any propaganda activities of foreign and domestic antisocialist forces. The past decade of negligence in raising the rising generation of Poles also is making itself felt. Thus there is an urgent need to take more effective action in order to eliminate the uncovered negative attitudes toward military service, attitudes that most often arose in an elemental manner, and to shape and perpetuate more intensively positive attitudes, that is, attitudes consonant with the vital interests of the army and the society.

My studies comprised 300 servicemen. Young people begin their basic military service while variously disposed toward it. At the moment of commencement of military service only 55.7 percent of the draftees expressed a positive attitude toward it, 14.3 percent were neutral, and as many as 30 percent declared themselves to be negatively disposed.

Justifying their responses, part of the servicemen representing a positive attitude toward military service declared that an active participation in training and civic work as well as a diligent performance of military duties

is their ambition. Let me quote certain answers: "I want to get a good training," "I want to upgrade my vocational skills," "While a civilian I did civic work and that is why I want to continue it while in the army," "I want to perform my military service peacefully, but at the same time I desire to complete the noncom school and pass on my newly acquired knowledge to my junior fellow servicemen," and "I joined the army in order to fulfill properly my duty to the fatherland."

Among servicemen with a neutral attitude toward military service the following views dominated: "I always preferred to stay in the middle, and during my military service I want neither to do too little nor exert too much effort," "I want to finish my military service, because I have to, and return to civilian life as soon as possible," and "I'll perform my duties only when I can derive personal gain from them."

The draftees taking a negative attitude toward military service argued that, among other things, military service prevented them from getting a better-paying job. They also mentioned separation from family and friends as well as lack of psychophysical predisposition for performing military service. Some also justified their negative attitude toward military service by claiming that their stay in the army postponed for 2 years the fulfillment of their personal plans. Other answers given were: "I came to do my service rather than do meritorious service," "I don't want to work up a sweat only in order that others may lie abed," "In general, the army doesn't interest me," and "All I want is to stick it out, because it doesn't pay to be an eager-beaver."

It is alarming that a relatively high percentage of the respondents offered inaccurate opinions on military service, although, under the mandatory programs, they are supposed to learn defense-related topics in school. The unwilling attitude toward military service is due to many factors, both social and psychological ones. One such factor is of a certainty deficient rearing at home, in school, at the workplace and in the community. In addition, before joining the army, young people often become influenced by the political enemy, who has accomplished a marked devastation in the awareness of the rising generation. Sometimes, draftees leaving for the army are bidden farewell by priests who call upon the young people to maintain an at least passive attitude toward political training, activities of the youth organization, etc. As a result, when crossing the barracks gate, a substantial proportion of draftees are politically disoriented, inhibited and mistrustful toward military service. Moreover, young people have witnessed or taken part in the sociopolitical changes taking place in this country, changes under whose influence they continually revalued their views. Such attitudes have undoubtedly also been influenced by the situation in this country and negative role models, the survival of petty bourgeois ideals and a leaning toward the consumerist lifestyle.

A deeper analysis of the collected opinions gives reason to believe that other reasons for the negative attitude toward military service are: separation from the family and close friends, the need to subordinate oneself to military discipline, the changed social conditions and lack of faith in oneself. Young people hear, particularly in the period prior to their conscription, various and often greatly distorted rumors about army life. At times, stories about

military service are "circulated" among conscripts by persons who never performed it, with the stories themselves having a subjective coloring and promoting a negative attitude toward the army.

In the course of their military service, servicemen develop a more positive attitude toward it. To be sure, in certain cases the changes in attitude have been to the worse rather than to the better, this being caused chiefly by hardships associated with military training and life and deficiencies in the training process due to deviations from military regulations and poor personal relations with immediate superiors as well as among servicemen themselves.

Individualized analysis of the respondents revealed that the development of more negative attitudes toward military services was also prompted by the failure of superiors to properly appreciate some of their subordinates. This is demonstrated by the comments of those servicemen who stressed, "I always tried to do my duty properly, but I wasn't noticed."

At the moment of completion of basic military service, changes in attitude were also recorded for another group of servicemen. These changes occurred solely among the persons who had previously declared themselves to be negatively disposed toward military service. In 4 percent of the respondents the changes were in the positive direction, and in 4.7 percent, in the neutral direction. Altogether, during the period of their military service, 15 percent of servicemen changed their attitude toward it, with nearly one-half feeling more positively disposed toward it. These favorable training results were due to the implementation of the instructional process and ideological-political work, particularly political indoctrination.

It is perplexing, though, that, at the time of their discharge from military service and transfer to reserve status, a high percentage of the respondents remained negatively disposed toward military service. This demonstrates that it was not possible to completely compensate, while in the army, for the educational deficiencies at home, at school and in the community. On the basis of interviews with the instructional and command cadre, several factors causing this situation were identified. They are: domestic and foreign influence of the antisocialist forces, the immature attitude of youth toward problems of national defense, differing social conditions, difficulties and shortcomings in the instructional process and the personal interests of the respondents.

The material collected makes it possible to determine more precisely practical indications for developing positive attitudes toward military service. It appears that the need of youth for more information about the army should be met to a greater extent during the pre-conscription period. Starting at home and continuing at school, in social organizations and in the mass media, the real purpose and picture of military service should be made known to youth. This would contribute to eliminating, or at least limiting, tension and anxiety during the period prior to drafting for military service.

Insofar as possible, the requests of draftees for assignment to specialties consonant with their liking, interests, qualifications and predispositions should be considered favorably. But it cannot be presumed that even then all

young draftees will feel enthusiastic about the army. Military service should, as before, continue to be treated as an extension of the rearing process and oriented, particularly during the first few weeks and months after the draftees join the army, toward the eventual elimination of the deficiencies in rearing youth at home, at school and in the community, for military service.

The point chiefly is to instill in servicemen within a relatively short period of time the conviction that every form of training and instruction is indispensable from the standpoint of concern for maintaining an adequate level of national defense. This process should be initiated by spurring all service, party, youth and social elements to become more active in imbuing the training cadre with the conviction that it is necessary to provide a good personal example in quotidian military life. The cadre, in their turn, should encourage draftees performing basic military training to emulate them. The related expectations will be met only when the entire training cadre will display uniform and proper soldierly attitudes.

I believe that everything should be done to facilitate for young servicemen adaptation to military service. To this end, the still existing improper attitude of the command cadre, and particularly of noncommissioned officers, toward the draftees should be eliminated, as should be the improper attitude of seasoned servicemen toward novices; this applies particularly to bad customs and hazing.

The professional cadre should show greater interest in the life of servicemen during the afternoon hours. I am not suggesting that they stay in the barracks from Reveille till Lights Out, but in every unit and subunit there exists as a rule prolonged supervision or work based on the two-shift system [as published]. The point is merely that the cadre members assigned to work in that system perform their duties conscientiously. It is advisable to organize during those hours genuine rather than make-believe cultural, educational, recreational and sports activities and to supervise properly clean-up, dormitory and other duties specified in the schedule of activities.

The above conclusions do not, of course, resolve the problem entirely. It seems to me, however, that they can provide a foundation for refining the existing forms and methods for troop training and exploring new ones.

#### Negative Attitudes

Warsaw WOJSKO LUDOWE in Polish No 10, Oct 85 pp 43-45

[Article by Maj Bogdan Sambor: "What Should Be Done With 'The Maladjusted Ones'?"]

[Text] In recent years interest in problems of social pathology has markedly grown, this being due to, among other things, the definite increase in the number of socially maladjusted individuals. This phenomenon is due to the decline in the upbringing and rearing function of the parental home and the rise in the numbers of youth raised in single-parent families or without parents. The problem of maladjustment is also influenced by the phenomenon of

acceleration, that is the marked acceleration in the physical growth of young people accompanied by a merely slight acceleration in their personality growth. The resulting disparity results in retarding social maturation and generates conflicts and rearing problems. The growing social maladjustment, and particularly such of its forms as criminal behavior, hooliganism, alcoholism, drug abuse, work shirking and school truancy or lack of respect for others, produce definite effects in the educational milieu of the army. Hence also an adequate definition of maladjustment, and particularly the isolation of its causes and symptoms as well as the determination of ways of its diagnosis and treatment, is of cardinal importance to educational work in the army.

#### A Problem of a Social Nature

The introduction of the term "social maladjustment" is linked to certain previously existing concepts of theory deriving from the biological sciences and pertaining to the organism's capacity for "homeostasis," that is, for maintaining an equilibrium under varying environmental conditions and being capable of adapting to them. Interpretations and definitions which construe adaptation as the regulation of mutual relations between the organism and the environment are generalized and incomplete, because man as a being that is not only biological but also social must, in order to survive, be capable of adapting himself not only to a new biological environment but also to a new social environment.

Adaptation is also construed as a unilateral regulation of one's relations with the environment. This is a major oversimplification. Such a concept reflects a conformist attitude and stresses the value of so-called guile in everyday life. It reflects the absence of an inner need to change primitive behavior and attitudes. This is adaptation to actually existing conditions and requirements, and at the same time it denotes relinquishment of originality and autonomy in the development of one's own selfhood.

Similar controversies and divided opinions arise when defining the term social "maladjustment." Often it is regarded as tantamount to, and interchangeably used with, such concepts as "maladaptation," "behavioral disturbances," "deviant behavior" and "behavioral problems."

There exist at least two good reasons why the term "social maladjustment" should be employed. First, there is the tradition of this concept in Polish educational writings and practice. This term, established by the World Union of Child and Youth Care Institutions, was introduced and propagated in Poland by Maria Grzegorzewska. It also is part of the terminology employed by the Ministry of Education and Upbringing. Second, this term is of value on its own. For it accents the relationship between the individual and his social environment and shifts the onus of the problem from the individual -- the "difficult," "derailed," "morally negligent," "poorly socialized," "behaviorally disturbed" individual -- onto the problem of his relations with the environment and stresses the importance of the environment itself.

It can be assumed that social maladjustment applies to youth whose relatively permanent recurrent behavior displays a set of symptoms pointing to failure to adhere to certain fundamental rules of behavior and mandatory social norms. In other words, this is a situation in which the individual cannot coexist harmoniously with his immediate community, cannot achieve even elementary social intercourse with the persons he encounters in his everyday life.

And what if he is in the army? We may conclude that maladjustment to military service represents a set of fairly regular symptoms and modes of behavior of servicemen, manifesting themselves in failure to obey military regulations and orders, failure to adhere to norms of life and conduct mandatory in the educational environment of the army.

### Symptoms and Their Causes

To apprehend the nature of social maladjustment and take effective preventive and resocializing measures, the causes of this negative phenomenon first have to be cognized. The genesis of maladjustment is unusually complex. This ensues not so much from the magnitude and diversity of the causes as, above all, from their intertwining and numerous interrelationships. Hence, analysis of the causative factors of maladjustment requires a comprehensive approach. Here the possibilities are many. Certain causative factors operate simultaneously, while others arise fortuitously and operate singly. In every individual case the nature of the causal interrelationships and the mechanisms of their combined operation have to be uncovered. Next, in the course of such analysis, the decisive factors as well as the factors promoting the phenomena of maladjustment have to be identified.

In the genesis of the social maladjustment of servicemen we should allow for personality, environmental and situational factors. Among the environmental and situational factors unrelated to military service we can include, e.g., family conditions (formal and moral decay of the family, its size, alcoholism of parents), improper attitude to study and work and a difficult material and housing situation. As for the factors relating to the educational environment of the army, they are principally: improper organization of labor (service and rest), improper educational techniques (excessive military rigor and exorbitant demands of superiors) and certain other situations (excessive duties, arrangements causing in-group conflicts, etc.).

As for the personality factors, they are chiefly: needs (motives), knowledge and experience, character, attitudes, views, beliefs, interests, social activism and certain personality disorders.

We derive information on the extent of maladjustment to military service from symptoms represented by various forms of negative conduct of servicemen. They are of a complex nature and usually occur in groups (syndromes) of maladjustment symptoms. Let us add that they occur in variegated forms and do not always point to social maladjustment. Thus, e.g., lack of progress in training, undisciplined behavior and tardiness may merely signal temporary indisposition, fatigue or exhaustion. Hence, the occurrence of symptoms in itself still does not warrant the diagnosis of social maladjustment. Symptoms

of maladjustment differ from the abovementioned temporary perturbances in wellness in that they are of a relatively permanent and recurrent nature.

The most characteristic -- in my opinion -- symptoms of maladjustment to military service may include:

- lack of discipline and dutifulness, failure to adhere to military regulations, norms and orders;
- illwill displayed toward fellow servicemen and superiors as well as inclination toward causing conflicts;
- reluctance to work, study and serve;
- low feeling of responsibility for one's own deeds;
- suggestiveness, inability to resolve difficult situations;
- low activism and poor psychological resistance to the hardships of military service;
- aggressiveness, living for the moment, search for adventures, troublemaking.

#### Much Depends on the Choice of Methods

Early detection of the root causes and symptoms of maladjustment to military service is a fundamental prerequisite for rational educational countermeasures. The better and more penetrating the recognition of personal predispositions and environmental influences by commanders, the more rationally can they select corrective and educational countermeasures, and the more effectively can they organize preventive and resocializing activities. To obtain the full picture of the causes and symptoms of maladjustment and uncover their interrelationship and mutual dependences, superiors should resort to a diagnosis that can be made on the basis of:

- systematic observation of the conduct of servicemen;
- person-to-person talks;
- interviews with the serviceman's immediate superiors, parents, fellow servicemen, etc.;
- examination of military documents (penal and distinction records, reports on analyses of discipline);
- analysis of personal records (so-called personal documents, i.e., letters, diaries, drawings, etc.).

The diagnosis should be the basis for a prognosis consisting in the formulation of expectations as to the eventual future conduct of the servicemen, the prospects for their training and the possibilities for their

resocialization. Such expectations sometimes prove to be illusory. For this reason, it is best to formulate prognostic conclusions cautiously, in the form of hypotheses.

Early detection of the causes and symptoms of maladjustment should facilitate for commanders the selection and application of optimal forms and methods of therapy and enable them to react properly to the personal difficulties and problems of servicemen. To be sure, the term "therapy" as employed here is hardly the most felicitous one, for maladjustment is not a disease medically speaking. Modern approaches to the treatment of the socially maladjusted are dominated by the use of methods, techniques and measures of the psychological type, referred to as, among other things, "psychotherapy."

Psychotherapy is deliberate and systematic treatment employed by qualified physicians and psychologists with the aid of such tried and routine techniques as hypnosis, psychodrama, autogenous training, relaxation exercises, etc. This kind of psychotherapy, rather termed deep psychotherapy, is handled in the army by specialized centers, psychological centers, military mental health clinics, psychiatric wards of military hospitals, and also civilian mental hygiene clinics in garrison towns. Deep psychotherapy is sometimes regarded as the sole way of altering a serviceman's personality and eliminating the causes and symptoms of his maladjustment.

Educational work in the army indicates that this is not a valid view, since psychotherapy should also be construed in the broader meaning of the word as any action of a psychological-pedagogical nature intended to eliminate or reduce symptoms of maladjustment and affect their causes. When so construed, psychotherapy, sometimes termed sustaining psychotherapy, is applied when the problem is to accomplish direct positive changes in a serviceman's personality within a short period of time. This kind of psychotherapy can be rapidly utilized in educational work in the army, chiefly in view of the specific nature of military service, the intensity of training and upbringing and the ensuing need to employ simple methods that are generally familiar to commanders and that can within a short period of time induce positive changes in servicemen maladjusted to military service.

Underlying every method and technique of psychotherapy employed by subunit commanders should be a deliberate and planned effort to influence the serviceman's psychology by words and conduct. But the words must be accurate and pertinent, while the conduct should be worthy of emulation.

The selection of the kind and particular technique of psychotherapy at the subunit level depends largely on the nature of the causes of maladjustment and the intensity of its particular symptoms. Identification of these causes should be individualized as much as possible. This will make possible the adaptation of techniques to the personal traits and qualities of the individual serviceman. I believe that subunit commanders should chiefly employ the simplest and generally known methods of psychotherapy, such as: person-to-person talks, suggestion, persuasion, emulativeness, elucidation, conviction, occupational psychotherapy, recreational psychotherapy, etc.

## Person-to-Person Talks -- Yes, But Not Only

The most often applied and by now traditional method for the diagnosis and therapy of maladjustment to military service is the person-to-person talk , intended to explore the reasons for poor behavior and faulty attitudes toward military service (toward superiors, fellow servicemen) as well as to assuage and eliminate the causes and symptoms of the observed irregularities. The person-to-person talk should provide the conditions for eliminating psychological tension and stress; the conditions for "talking it over" on subjects that emotionally grip the serviceman. This concerns in particular the servicemen who are in a state of intense emotional tension.

In such cases it is necessary to create an atmosphere of trust and goodwill, an atmosphere in which the serviceman can feel unafraid to talk about the things that worry, upset or anger him. But not every such talk can produce the intended effect. Much depends in particular on the ability to establish rapport with the serviceman. A stiff, dry, formal conversation is doomed in advance to failure.

Another educational technique in the field of psychotherapy is emulativeness. Quite often, owing to emulativeness consisting in a strong relationship of empathy, servicemen identify themselves with their superiors, meaning that they accept not only their modes of conduct and action but also their convictions, goals in life and ideals. This affords a great, though not always properly utilized, opportunity to set things aright.

Another equally effective method is persuasion, which consists in elucidation, conviction upon citing arguments, indication of ways out of a difficult situation, awakening of optimism and hope.

Still another method is suggestion . It consists in influencing the conduct, decisions, thoughts and imagination of the serviceman by force of personal authority or conviction. This influence should consist in inducing concentration, interest and endeavor to accomplish particular tasks. This is a process of verbal communication consisting in the direct inducement of a particular mode of conduct or in the acceptance of a particular conviction, opinion or plan of action. Suggestion is useful in alleviating or eliminating symptoms of maladjustment, indisposition, diffidence and bad habits.

A method that is worth recommending to every subunit commander is occupational psychotherapy . This kind of psychotherapy is indicated for apathetic and listless servicemen who are dissatisfied with the duties they perform. There exist many forms of occupational psychotherapy, such as athletic activities, tourism, organization and participation in cultural-educational work, active and passive participation in artistic entertainment and engaging in hobbies.

In addition to occupational psychotherapy, which requires of servicemen that they participate in various practical activities, it is worth employing recreational psychotherapy . Generally, this consists in the ability to utilize rationally leisure time, to organize leisure effectively.

The dynamics of the process of training and education and the attendant large number of difficult situations result in a relatively frequent occurrence of states of tiredness, exhaustion and fatigue among servicemen. An effective method for counteracting these phenomena is active mental and physical rest and recreation. However, this basically requires a broad gamut of forms of action by commanders, the youth organization, the servicemen's club and the cultural councils. This concerns affording to servicemen the possibilities for choosing on their own the most interesting activities. Personal freedom of choice of the forms of rest should be coupled with awakening the interests of soldiers in the desired direction -- this enriches personality and shapes character.

The successful course and effects of the application of elements of psychotherapy by subunit commanders are conditioned by many factors, among which personal authority and winning the total trust of the subordinates deserve special attention. The goodwill, trust, candor and authenticity of the superior as well as his self-criticism do not undermine his authority but on the contrary create the conditions for mutual understanding and exploration of ways of resolving the educational problems that arise. The provision of assistance to servicemen in resolving the problems associated with maladjustment to military service is an elementary task of superiors in the field of psychotherapy.

It may be that the thoughts and opinions presented above will prove helpful in everyday educational work. It may be that they will facilitate to some extent the practical implementation of the educational-corrective function of the army with respect to the socially maladjusted young people, because they also are found in units and subunits.

1386  
CSO: 2600/94

POLITICS

ALBANIA

MEDIOCRITY IN EDUCATION, PRODUCTION, SCIENCE DEPLORED

Tirana ZERI I POPULLIT in Albanian 23 Nov 85 p 1

[Article: "To Eliminate the Danger of Conformity to the Average and Mediocre Standard in Each Area of Life"]

[Text] The constant demand of our party, renewed laterly, for the ceaseless raising of the level of work in all sectors, for the deepening of the battle against average and mediocre standards, and especially for the elimination of the danger of conforming to them, is consistent with our socialist development and construction. This incontrovertible reality is being understood always and better by the organizations of the party and their levers, which, wherever they aggressively operate, have increased the mobilization and the efforts to further our achievements in all fields.

But within this positive framework, a dominant characteristic of our life, we notice that there is no lack of conformity to the average level and, in some cases even to the mediocre. To conform means to familiarize yourself with this level so that it makes no impression on you. Cases of conformity to this level are noticed, for example, even in the activity of some organs or basic organizations of the party. Studies are made by them, but occasionally they are of an average level, and, nevertheless few people say a word or make any criticism in this regard. Thus, in some of their meetings the problems are handled on an average level and as a consequence, the decisions made are also of this level, so that even the solution given to the matters is not always in good order.

Or let us take the field of education. Among the schools from one district to the other there are unjustifiable inequalities and irregularities. But you meet this even within one district, let us say, Tirana District. The factors are different. Prominent among them also is the unequal level of the teaching personnel, and also the unevenness of their work. In the teaching personnel of some schools there is also a mediocre element, some are even incompetent. This is expressed in the ordinary level of their training, of the instructional work. These teachers, even though they are few, hinder the scientific-pedagogical modernization of our school. There are cases like this even in the schools of higher education. The party has strongly set forth the need

of replacing the incompetent with new and capable cadres. Good, but what happens? There has been little movement about this. And this because in our educational circles the spirit of laxity and of reciprocal compromising sometimes raises its head, petty bourgeois sentimentalism, which in the final analysis has conformed to these negative phenomena. The organizations of the party which operate aggressively in education have an important work front in this matter. They must be required to arouse the awareness of every communist and cadre of their sector to strongly fight every manifestation of conformity to mediocrity and incompetence, to create in them the strong conviction that this battle will not end with any partial measure, it must develop without interruption. Otherwise as the party has emphasized, we shall be obliged to pay tribute to mediocrity and incompetence, today and later, since their presence creates the atmosphere of low expectations, of contentment with little, of sluggishness and of laziness. From this viewpoint it is necessary that the party organizations of the "Enver Hoxha" University of Tirana, of the Higher Agricultural Institute in Kamze and of the pedagogical institutes of Shkoder, Elbasan and Gjirokaster reflect on this problem more than they have been up to the present. They must always bear in mind the valuable instruction of Comrade Ramiz Alia that "this is an uninterrupted and long struggle not only to replace those who actually are unfit, but also not to let the young cadres fall into slothfulness and content themselves with lesser expectations when they, at the beginning, have an opportunity to get ahead."

The mentality of conformity and of contentment with the average and sometimes mediocre level is also manifested in the field of production. Are there not efforts by certain heads of glass factories to conform to this standard when it is known that there is considerable waste there? The very "argument" they present that "the very nature of the work justifies the waste," is evidence of that harmful mentality. The average and mediocre standard exercises powerful pressure on the heads of construction enterprises as far as quality is concerned. The requirement of an accounting for the quality of the buildings is low, so there is rooted in them the psychosis "that is all we can possibly do," at a time when in this sector there are innumerable examples which witness to the opposite. The question is justly posed: What would happen if the mentality of being content with the average should take the guiding position in production? This would be a completely negative phenomenon which would hinder the realization of the duties of the plan, it would hinder carrying the work forward, it would cause serious disorders. In order to eliminate the displays of the mentality of contentment with the average in production, the communists of this front must be in the forefront, they must take more responsibility to combat these things, first of all in themselves and afterwards in the others also.

The further development of our sciences in the service of the socialist construction of the country and the strengthening of the defense of the Fatherland depends, considerably, upon the deep understanding of the necessity for combatting conformity to average and sometimes mediocre standards. There has been average scientific research work both in the general framework of science and also in the activity of a scientific-research institution. It may happen that conformity wins "citizenship" rights for those scientific workers who are themselves the creators of this standard. But it is unforgivable

when it justifies itself by scientific criticism, or passes and is approved by scientific councils. And cases of this nature are not lacking. Some critiques abound in boasting and praises for ordinary scientific works, just as on some occasions, there are undeserved eulogies for some weak study by some scientist who has a leadership role. Such attitudes are inadmissible and run counter to ethics and socialist morality. It is learned, for example, that in the "8 November" Publishing House some dissertations defended in various fields of the social sciences, although the critiques spoke in superlatives, never saw the light of publication since their level in some cases was below average. The tendency is not right nor at all serious, but is noticed in some educators of the schools of higher learning or scientific workers of the social science institutions, who, as soon as they receive their science degree, fall into a lethargic sleep.

The psychology of conformity to the average or mediocre level in science, and also in literature and the arts, is often helped by factors such as: bureaucracy, incompetence, a petit-bourgeois spirit and sentimentalism. These phenomena pave the way for routine work, with no intellectual reinforcement whatever. They cultivate mediocrity and lower the effectiveness of scientific research work. If we should conform to them, this would mean that we would seriously damage the creative process in science. Thus, in science as everywhere else, the mentality of setting and of conforming to an average standard must be the object of examination and very attentive concern on the part of the organs and organizations of the party, with the aim of uprooting it.

Our reality and achievements in all areas of life permit the organs and organizations of the party, with skillful and efficacious propaganda, to create in everybody a conscientious conviction to constantly deepen the struggle against conformity to the average and mediocre mentality. Persuading others begins with persuading the communists. This indisputable truth is proved by numerous examples from life. The motto of work in every area of our life must be: quality and high standards. For this, all the necessary conditions exist.

13083/6662

CSO: 2100/13

POLITICS

HUNGARY

PPF DEBATING 'DIRECT' DEMOCRACY, POPULAR REFERENDUM

Budapest ELET ES IRODALOM in Hungarian 13 Dec 86 p 7

[Interview with Istvan Kukorelli, lecturer at the Lorant Oetvoes University Department of State Administration, member of the PPF: "Do We Need Popular Referenda?"]

[Text] Reports of plebiscites are coming from abroad continuously. The population has made a decision on the building of a power plant, on the compulsory use of a safety belt, or most recently on experiments conducted on animals. But if in Hungary we glance into any book or study dealing with the subject, we find that the authors cannot emphasize it enough that "direct democracy plays an essential role in the operation of socialist states," and that "we must revive the dead institution of the plebiscite." Dr Istvan Kukorelli, lecturer at ELTE [Lorant Oetvoes University] Department of State Administration, is one of the creating founders of the debates that deal with the present possibilities of plebiscites and that are becoming more and more frequent even within the People's Front.

[Question] When was the last plebiscite held in Hungary?

[Answer] Shortly after the signing of the Trianon Treaty, when by the terms of the international agreement the population of Sopron and the surrounding villages had to decide whether they should belong to Hungary or Austria. This was the last plebiscite in Hungary regarding international law, and since then there was only one discussion of plebiscites in 1949 and then, too, only about whether they should be put in the Constitution. They were. Article 30, paragraph 1 and point d) of the Constitution states that the Presidential Council may order a plebiscite in matters of national importance. But none has ever been held. And legal regulation was exhausted with the one passage in the Constitution quoted above. There is not a single statutory provision to define the legal and technical procedures, or who would be obligated to do what with the plebiscite results. Also, it is not clear what is meant by a question of national importance.

[Question] What could be the reason that legislation has not used the plebiscite? Are we perhaps afraid of direct political participation by the citizens?

[Answer] It is stipulated in the Hungarian Constitution that every citizen has the right to participate directly in the exercise of public affairs at the two most important areas of public life, the work place and the place of residence. But with reference primarily to the teachings of Leninism, direct participation was interpreted in an extremely broad sense during the early decades of building socialism. Party democracy was interpreted as direct democracy, as well as trade union, cooperative, factory and residence democracy. In response to this manner of thinking, everything that exists in Hungary as a social organization--association, committee, meeting--and there are some--are all forums of direct democracy down to the very last one. If we can exercise direct political participation in such broad scope, why in the world would we need another forum, especially a plebiscite. This particular interpretation prevailed primarily because the lines of division between the state and social spheres disappeared completely. The state will die out, all state functions will become socialized--this appeared as the perspective for the near future. Subsequent experiences showed, however, that the need for state and state power was to remain for a long time to come. If this is true, we cannot give up the forums of direct democracy from the constitutional point of view. The democracy of public life as a whole is one thing, and direct democracy linked to the democratic exercise of state power is another question that must also be regulated by law.

[Question] But why so late, why in the 1980's has the situation matured to where there is a call for the revival of plebiscites?

[Answer] The professional literature dealt with this matter before. It is true that the subject nowadays is once more in the spotlight. Perhaps because in the wake of the social and economic changes it became evident in the 1980's that the representative institutions of democracy in themselves do not always guarantee that the citizens will shape the nation or even the local decisions in accordance with their interests. Society is highly subdivided, never has it been so subdivided since 1949. Not only according to the property situation, living standards, place of residence and occupation, but also ideologically and politically. What do people want, what is good for them? In response to this question--if one may say so--the organizations and institutions called on to mediate interests answer with a hard swallow; whether it is a matter of national importance or a place of residence question. Political participation by the citizens in the exercise of state power is not guaranteed by the right to vote or representative democracy in itself. All this can be usefully complemented by direct democracy. Direct democracy carries an important political right, it may mediate the views of the public in a more direct form.

[Question] In questions which greatly occupy public opinion, how can the population or a social organization--let us say the People's Front--ask for a plebiscite?

[Answer] I cannot refer to legal bases because there are none. The Constitution invests only and exclusively the Presidential Council with the right of initiative. It is a contradictory situation. Not even the National Assembly, the highest legislative body, has such a right. This shows, incidentally, that in Hungary the power of the Presidential Council is greater than it ought to be in certain questions. It needs study and modernization together with the

question how the voters may initiate an important law, decree or decision. Let me note that another institution of direct democracy is known in Hungary, the right of citizens to make a recommendation of public interest. Anyone at anytime may recommend something. True, it might be difficult to read into this the institutions of the "people's initiative" because the recommendation of public interest is an individual and not a collective right.

[Question] In foreign countries who has the right to initiate a plebiscite?

[Answer] In the middle-class constitutions obligatory and optional referenda are known. These may be initiated by state organs. In some countries this is the right of the head of state, in others it is only the right of parliament, but it is also known as the right of the supreme courts or constitutional courts. On the other hand, the population, or more precisely a certain number of voters, may take the initiative. There is a difference between referenda for accepted laws and the people's initiative. For the latter, by way of example, you need 50,000 voters in Italy; in reference to the constitution of the federation, 100,000 voters in Switzerland; and 200,000 voters (or at least half of the voters in the three provinces) in Austria for a plebiscite to be called on the basis of signatures.

[Question] As I understand it, they passed a law several years ago in Bulgaria on plebiscites.

[Answer] A law was approved in 1983 which invests the citizens with the right of recommending a plebiscite. The signature of 30,000 voters is necessary. This shows that the plebiscite can be organically fitted in the political system of socialism. And there is also possibility in the GDR and the Soviet Union to submit an approved law to plebiscite, sanctioning it as it were by the population. This kind of sanctioning--referendum--is a very important institution, and in given cases it may even reject a decision of parliament as well as affirm it. Actually, it is nothing other than feedback, the legislators can in this way control their own work.

[Question] Has the plebiscite possibility ever been used in the above-mentioned socialist countries?

[Answer] I can only give examples of social debates.

[Question] Is it conceivable that in Hungary an approved law or decision of national importance will ever be put to a plebiscite?

[Answer] I can imagine a bill being taken to the people. To sound out the population what its opinions might be about the possible alternatives in the bill.

[Question] Something like that has already occurred; for example with the new voter rights law. And most recently, the settlement development contributions have been occupying the population.

[Answer] That is right, but we should not confuse the plebiscite as a legal institution with social debates. There have been debates on the voter rights law at 1,300 forums. These debates served primarily the purpose of legal information, but of course many valuable ideas have also surfaced. The codifiers used these suggestions, but nothing bound them as to what should be built into the bill. The results of a plebiscite bind the legislators. The disadvantage, however, is that it simplifies the decision to its yes and no alternatives. The settlement development contributions may possibly be a better example. The population may decide for what it wants to give and how much. This is undoubtedly democratic. But in the basic question whether or not it agrees with the "toho" institution it cannot decide. This is presented in final form to the citizens. I would have thought it better to hold a plebiscite on the decree with the force of law which was passed by the Presidential Council regarding teho, and parallel with it survey the requirements that the people will have in the settlement and district. What are they willing to do, are they willing to give any money at all? It should be the role of the plebiscite to give the citizens an opportunity to influence legislation directly and not only to participate in debates.

[Question] Even the supporters of plebiscites have a number of concerns. Namely, that the voting can become irresponsible, with lay persons making decisions on matters they do not understand. And that they would vote on an emotional basis.

[Answer] True. Even in countries with the greatest democratic tradition the danger exists that the plebiscite can raise obstacles to progressive decisions. Historical experiences show--for example, the 1938 Austrian plebiscite on the Anschluss--that the institution can be an instrument of abuse; the spectacular, the theatrical, during which emotions dictate. It is enough to mention that in French history they voted for everything in plebiscites--even for contradictory kinds of constitutions. And still I regard it as a greater danger if the government does not try to bring its decisions face to face in this form with the citizens. Even the very existence of a correct law on plebiscites which extends to every process will stimulate the citizens to political sensitivity and activity.

[Question] But I wonder whether we need not worry about a lack of interest.

[Answer] In those countries where there is a plebiscite tradition they regard a 60 or 70 percent participation as a great success. Even in Switzerland, the country of referenda, they do not think in terms of full participation. I believe that if we think about it realistically, the politically active stratum is not 99 or 100 percent in Hungary either. I regard this as natural and I would not fear if, let us say, one-half of the voters went to the polls at plebiscite time.

[Question] If it were up to you, what kinds of questions would you hold plebiscites on?

[Answer] At the national level the plebiscite could have a role in the legislative process, above all in legislation. But being familiar with the

circumstances, I believe now there is a much greater chance for plebiscites linked to local self-government; that the population of a city, for example Dorog, should be able to decide by itself whether it wants a waste incinerator; to decide whether there would be a promenade in the center of Bekescsaba or not. The passing of council decrees can also favorably be linked to the institution of direct democracy. Today we speak of an open settlement policy, and I cannot conceive of this without the institutions of direct democracy. Not to speak of the fact that while at the work place, at least in principle, people may address themselves to common affairs in a broad scale of forums, there is practically no possibility for this at the place of residence. The citizen, if you please, is "buttonholed" where he makes his money, and therefore it is all the easier for him to raise his hand in vote. Too bad that at his place of residence he has less opportunity to take part in questions affecting his life.

6691/8918  
CSO: 2500/163

POLITICS

POLAND

ELECTION, POST-ELECTION NOTES

Commission, Convention Differences Outlined

Warsaw ZOLNIERZ POLSKI in Polish No 31, 4 Aug 85 p 8

[Article by Robert Jordan: "Electoral Conventions and Commissions" under the rubric "Vademecum of the Young Voter"]

[Text] The Convention

This is a new concept in our electoral law. What does it mean? A convention is simply an electoral collegium, familiar to us from last year's elections to people's councils. Its role and purposes are nearly the same, namely: to identify candidates for deputies from among persons nominated by authorized organizations.

The All-Polish Electoral Convention (OKW) consists of representatives of the PRON [Patriotic Movement for Poland's Rebirth] National Council and the leadership of the Polish United Workers Party, the United Peasant Party, the Democratic Party, the "PAX" Association, the Christian Social Association and the Polish Catholic-Social Union (the abovementioned parties and organizations are PRON signatories). The OKW also includes representatives of the leadership or national caucuses of trade unions, socio-occupational farmers' organizations, socialist youth associations and veterans' and women's organizations (who altogether account for two-thirds of its membership).

Province Electoral Conventions consist of representatives of province PRON councils, province leadership of political and social organizations and province caucuses (as in the case of the All-Polish Convention).

The conventions accept nominations of candidates for deputies and thereupon perform a selection among them (it is to be assumed that the number of nominations will be several times as large as the number of mandates). They also appoint ombudsmen from among persons nominated by the PRON and present candidates for deputies to voters (at consultative meetings and through the mediation of the mass media).

The conventions collect and consider the voters' opinions and comments on candidates, whereupon they determine the electoral lists and transmit them to the electoral commissions.

#### Electoral Commissions

The State Electoral Commission and the regional and district electoral commissions are established in order to conduct elections.

Members of the State Electoral Commission are appointed by the Council of State from among voters nominated by the Executive Committee of the PRON National Council and the leadership of the PRON signatories, that is, the PZPR, the United Peasant Party, the Democratic Party, the PAX Association, the Christian Social Association and the Polish Catholic-Social Union.

Members of the regional and district electoral commissions are appointed by presidiums of people's councils from among candidates nominated by corresponding elements of the PRON and local branches of the aforementioned parties and associations.

The principal tasks of the state and regional electoral commissions include: supervision of adherence to electoral law, registration of voters' lists, notification of voters about candidates by means of wall posters, counting the votes and consideration of complaints by voters.

Tasks relating directly to voting are handled principally by the district electoral commissions. They prepare the premises for voting, post lists of voters for public viewing, supervise the lawful conduct of the voting process itself, and count the votes in their districts.

A commission member whose name is placed on a registered list of voters may no longer perform his duties on the commission.

Commission members perform their duties on an unpaid volunteer basis.

#### Selected Voter Descriptions

Warsaw ZYCIE WARSZAWY in Polish 14 Oct 85 p 2

[Unattributed article: "Persons of Culture. . . [and] Clergymen and Nuns"]

[Excerpts] Among the voters there is no shortage of persons of culture, honored and popular artists. On the premises of the district electoral commission on Narbutt Street the pair of popular actors Lidia Korsakowna and Kazimierz Brusikiewicz cast their ballots. At the district electoral commission on Krasinski Street Jerzy Kawalerowicz, the director of such films as "Pharaoh," "Mother Joanna of the Angels" and "Death of the President," cast his ballot into the voting urn and thereupon told a PAP journalist: "I'm electing a Sejm that would cope with the challenge of overcoming the lag in various domains of our national life. After all, we're living at a turning point in the history of mankind. The veritable science and technology revolution that we're witnessing also requires a new look at cultural matters.

A new look at both the conditions and means promoting creativity and the state of awareness of artists, the public and arts patrons. It is precisely such a new way of thinking that we need most at present. "

At the polls in Warsaw the popular actors Elzbieta Kepinska, Wienczyslaw Glinski and Tadeusz Plucinski, as well as the well-known man of letters Aleksander Bochenski cast their ballots. At the seat of the district electoral commission on Wawelska Street the PAP journalist encountered Jan Mewysztowicz, vice chairman of the Polish Writers Union, who commented: "I participated in every election since 1947 and I can state with all certainty that today's elections are unprecedented. This concerns not just changes in electoral procedure but also and above all the atmosphere itself of the act of voting. People vote because they want to and indeed can decide the membership of the next session of the Sejm. "

The voters in Krakow included the rectors of 11 institutions of higher education in that city. At a district electoral commission in Krakow a ballot in elections to the Parliament was cast by Prof. Antoni S. Kleczkowski, the rector of Krakow's largest technical college, the Stanislaw Staszic Mining and Metallurgical Academy. He commented: "Our country needs stabilization and peace. We must emerge as soon as possible from the difficult situation in which we found ourselves. For this very reason we must demonstrate our will to act during the present difficult period. We want to entrust our mandates to those who are indeed the best.

#### Clergymen and Nuns

In Warsaw Bishop Tadeusz Majewski, the chairman of the Synodal Council of the Polish Catholic Church, took part in the voting. He stated: "I'm glad that the 9th Session of the Sejm will include representatives of all walks of life, who shall work on issues of concern to all us Poles." Similarly, before noon, those appearing to cast their ballots at the Wola poll site in Warsaw included a group of Franciscan nuns from the convent on Zelazna Street.

Early in the morning at the district electoral commission No 570 on Ratuszowa Street Archbishop Bazyli, the Russian Orthodox metropolitan of Warsaw and the entire Poland, cast his vote. Together with the superior of the Polish Autocephalic Orthodox Church, in various polls in the Nation's Capital, all clergymen of that persuasion cast their ballots.

On the premises of the district electoral commission on Mikolaj Street in Wroclaw clergymen from the Russian Orthodox episcopal curia, headed by the Wroclaw-Sczeczecin Metropolitan Bishop Jeremiasz were among the Stare Miasto District voters who cast their ballots.

Similarly, voters casting their ballots in Chelm Province included representatives of the clergy. Among others, the voters in Ruda Huta included the curate of the local Roman Catholic parish Marian Chmielewski; in Depultycze, the Rev Curate Boleslaw Koltys, and in Zulow the Rev Antoni Czapinski. In-house voting at the Caritas Welfare Home in Nowiny, conducted by nuns, was completed even before noon. Together with the other sisters, the Mother Superior Stefania Mroz also cast her vote there.

The voters in Przybyslawice, Tarnow Province, included the curate of the local Roman Catholic parish the Rev Michal Dziedzic. He declared that it is the duty of all believers to take part in the elections. Let them vote for whoever they like, so long as they do vote. Forty nuns from the nearby convent in Skrzyszow also cast their ballots.

The premises of the electoral commission in Gostyn (Szczecin Province) were visited by the curate of the local parish the Rev Zygmunt Warszczuk and, along with him, several dozen of the faithful, who had earlier attended a prayer service.

Accompanied by many parishioners, the Rev Curate Janusz Krakowiak cast his ballot at the poll in Krasznice (Sieradz Province). Similarly, together with a 40-member group of voters, the curate of the local Losew (Lomza Province) parish Tadeusz Chyra cast his ballot in the elections.

#### Ninth Sejm Term Begins

Warsaw TRYBUNA LUDU in Polish 15 Oct 85 p 2

[PAP communique: "Ninth Sejm Term Has Begun"]

[Text] Although the results of last Sunday's vote are not yet known, the Ninth Term of the Sejm has commenced. For as established under the new electoral procedure, the term of the parliament is reckoned starting on Election Day. The new Sejm -- this supreme body of state power which translates into reality the sovereign rights of the nation -- will commence its activities with the next few days.

Pursuant to the Constitution, the first session of a newly elected Sejm should be convened within a month from Election Day. As regards the current Sejm, no date has yet been announced. The first session will be inaugurated by one of the most senior deputies, who will have the distinction of acting as the Senior Speaker. To those on whom the society bestowed its trust on 13 October] exercising a deputy's mandate will be a most important civic duty. The newly elected deputies will be sworn in by the Senior Speaker, and in their oath they will pledge themselves to perform their duties "thoroughly and conscientiously."

In his contacts with the Administration and various institutions the Sejm deputy will not be dependent on their goodwill or custom. The new decree on the rights and duties of Sejm deputies clearly states their right to inspect the activities of the organs of state administration and enterprises and to intervene in particular matters on their own and in behalf of the voters. Failure of persons employed in the administration, enterprises and organizations to cooperate in every way with Sejm deputies will be regarded as an infringement of their employment duties.

At its first sessions the Parliament will constitute itself and appoint the supreme bodies of state power as well as certain other bodies. First of

all, the Sejm will elect a new Speaker and assistant speakers. It will also elect from among its members the Council of State.

#### ZSL, SD Election Participation Evaluated

Warsaw TRYBUNA LUDU in Polish 16 Oct 85 pp 1,2

[PAP communique: "Mass Participation of Members of the Political Parties [Allied to the PZPR] in the Elections"]

[Text] Presidium of the ZSL [United Peasant Party] Supreme Committee

The Presidium of the ZSL Supreme Committee evaluated on 15 [October] the course of the elections to the Sejm. It stressed that the universal and mass participation of the society in these elections reflects its resolute support for the program of socialist renewal and reforms adopted in the resolutions of the Ninth Extraordinary Congress of the PZPR and the Ninth Congress of the ZSL.

The elections occurred in an atmosphere of seriousness, tranquility and display of civic responsibility by the voters, and this is testimony to and demonstration of the deep patriotism of Poles, of their feeling of civic concern for the future of the nation and state.

The participation of an overwhelming majority of citizens in the act of voting is also an affirmation of the society's unity on principal issues and its growing consolidation round the implementation of the program for building a socialist Poland -- a strong, secure and democratic Poland under rule of law and Poland of high international standing.

It was found that the particularly high mass participation of the rural population in the act of voting demonstrates its unequivocal support of the consistent implementation of the resolutions of the Ninth Plenum of the PZPR Central Committee and the ZSL Supreme Committee.

The Presidium of the ZSL Supreme Committee expressed its appreciation to the institutions, members and activists of the ZSL for their commitment and active organizational and political participation in the work relating to the preparation and conduct of the campaign for elections to the Sejm.

The Presidium of the ZSL Supreme Committee considered a report on the performance of Worker-Peasant Inspection Teams [IRCh]. The proactivism so far of elements and echelons of the ZSL in the formation and activities of the IRCh was evaluated.

The Presidium of the ZSL Supreme Committee also considered a report on the implementation of investments in the agricultural and food industry .

The Presidium of the Supreme Committee likewise considered the obstacles to the proper implementation of investments in land reclamation and farm water supply. It found that the financial resources allocated for these purposes by province people's councils are too small in relation to needs.

The materials of the 8th Plenum of the ZSL Supreme Committee relating to political and organizational tasks were considered in the light of the campaign for elections to the Sejm and the report meetings within ZSL clubs. It was resolved to convene the next plenary session sometime at the end of October and beginning of November of this year.

#### Presidium of the SD [Democratic Party] Central Committee

The Presidium of the Central Committee of the Democratic Party assessed on 15 [October] the elections to the Ninth Term of the PRL Sejm . It stressed that the course of these elections, the atmosphere of seriousness in which they were held, and the high degree of voter participation explicitly demonstrate that the society has declared itself resolutely in support of the continuation of the program for socialist renewal, the line of social and economic reforms and the strengthening of national consensus. A program for further strengthening of the state and democratization was chosen, thereby demonstrating support for the Election Declaration of the PRON [Patriotic Movement for National Rebirth], for the government's policies so far.

[The public's participation in] the act of voting expresses confidence in its representatives who, at the forum of the Sejm, shall promote the further development of Poland, accepting the duty of implementing the strivings and aspirations of the society. In their work the deputies should be guided by special concern for satisfying, insofar as possible, the postulates of the citizenry voiced during the pre-election campaign.

The elections, in which many more citizens took part than in the elections to people's councils, are proof of the further growth in civic activism and responsibility and constitute an unusually important stage in the further normalization of political life in Poland. The fact is worth stressing that attempts to boycott and disturb the elections had failed and were rejected by an overwhelming majority of the society.

The Presidium of the SD Central Committee was gratified to stress the universal participation of SD members in the elections, as well as the contribution of SD activists to the electoral campaign. The Presidium expressed its thanks to all SD members who had actively joined in the work to prepare and conduct the elections.

#### Commission Work on Internal Affairs Described

Warsaw RZECZPOSPOLITA in Polish 17 Oct 85 p 3

[Interview with Zygmunt Surowiec by Krzysztof Mikolajczyk: "Accepting the Social Realities: An Afterword to the Deputies"]

[Text] Z. Surowiec: "A Sejm deputy can't count on overtime pay. Being active in the Sejm is arduous, responsible and often thankless work to which every effort and most of one's time has to be devoted while the Sejm is in session. "

[Question] The problems of domestic security, public order and a broadly conceived administration of justice have always attracted the special attention of the society, particularly in the recent years with their abundance of tensions and open conflicts. What experiences in the work of the Commission do you consider to be the most important?

[Answer] All the matters considered by the Commission for Internal Affairs and Administration of Justice were important. This is due not only to the reasons you mentioned in your question but also to the fact that the scope of interests of our Commission has been very closely linked to the implementation of civil rights, that is, to matters which are of concern to every citizen. Hence, in our actions we must always be aware of the mood and needs of the society and constantly confront them with the requirements created by the political situation in this country, by the security of the state as a whole. In this task we have been assisted by, on the one hand, the regular contacts between the deputies and the voters and, on the other, a regular flow of information from representatives of the government, the judiciary and the law enforcement agencies; we were thus fully enabled to take the objectively most valid decisions.

[Question] The Eighth Term of the Sejm has been called, not without reason, the Sejm of Consensus and Renewal. This is demonstrated by the extensive changes made in the system of management and in the system of the exercise of power. . . .

[Answer] And also in the sphere of public order and security, in which the Commission for Internal Affairs and Administration of Justice has been directly participating. I refer here to the two amnesty decrees that made possible a return to normal life and to work for the good of the country and fellow citizens for, among others, persons who had for various reasons found themselves in conflict with the law during the martial law era. Mention should also be made of the legislative acts issued during that era itself which, in addition to many restrictions, also introduced the principle of abolition, that is, wiping the slate clean as regards politically motivated crimes and transgressions that had occurred during the years 1980-1981.

The process of [national] consensus was promoted by all the Sejm decrees and resolutions meeting public expectations. And it was precisely our Commission that had worked on these bills. Consider for example the decrees to prevent the demoralization of minors and counteract alcoholism and speculation which, after all, dealt with the social plagues that impeded most the life and work of the citizens. We revised the passport decree so as to democratize it markedly.

Generally speaking, let me state that the work of the Commission for Internal Affairs has in most cases pinpointed the direction in which broader changes in the laws in force would be made. To consider the abovementioned passport decree, as an example, regardless of how we judge the solutions adopted, they clearly point to the direction of the changes that will be introduced in passport policy. For the time being, however, we accomplished only as much as was warranted in our opinion by the social and political situation in this country.

[Question] But the public response has not been so unambiguous. This is probably due to the highly complex and sensitive nature of the issues with which the Commission for Internal Affairs has been dealing in its everyday work. If we also consider the time-consuming nature of parliamentary activities during the recent term of the Sejm, as well as the various external pressures exerted on the deputies, their role was not to be envied. . . .

[Answer] Anything that is new or unprecedented meets with a controversial reception. Some time has to pass before the society appreciates the solutions adopted. This is a long-known truth. I can only state that the Commission for Internal Affairs has analyzed with exceptional thoroughness every item on its agenda. We held 150 sessions and plowed through stacks of reports and expertises. We confronted voters about our opinions.

It should also be borne in mind that we have been working in unusually difficult conditions. The deputies were subjected to stressful external pressures from the political extremists, pressures that sometimes acquired exceptionally drastic forms. Besides, a deputy's work is always full of tension, if only out of concern for the good of the state and the constituency, out of constant concern and doubt as to whether all that could be done has been done. Yet, a deputy can't count on overtime pay. Being active in the Sejm is arduous, responsible and often thankless work to which every effort and most of one's time has to be devoted while the Sejm is in session.

[Question] I've often watched the work of the commission as directed by you, for more than 5 years. It's noteworthy that its deliberations have been mostly stormy, involving the collision of various and often opposed opinions. Nevertheless, on fundamental issues the deputies have mostly been in agreement.

[Answer] True. The commission consists of deputies who represent differing worldviews, differing knowledge, and the interests and experience of different groups or constituencies. This has always been reflected and will continue to be reflected in the discussions. The point is that the final decisions be the sum total of all the rationales of those who are for and those who are against. However deeply convinced of the rightness of his position, and despite the possibility of presenting and defending it in full, every deputy must bear in mind that it may not be accepted by others, that the opinion of the majority will prevail. This is a great skill and, in parliamentary work, even a necessity. Thus, the principal feature of a deputy's work is guiding himself by the interests of the state and the society as a whole. Group interests, the interests of a constituency, or other interests, must be subordinated to this paramount goal.

[Question] What conclusions does this suggest as regards the coming new term of the Parliament?

[Answer] I believe that the deputies should devote more attention to monitoring the implementation of the established laws, the more so considering that the lawmaking burden will surely be not as great as it was during the Eighth Term of the Sejm. The point is that the Sejm should focus on

examining the cohesiveness of the law system and its discrete domains as well as the lawmaking activities of administrative bodies and people's councils, while the Sejm commissions, particularly the Legislative Commission, should take an explicit position on these issues, in the form of desiderata. The onus of perfecting the law and monitoring its implementation rests and shall continue to rest on the Sejm and its deputies. The Ninth Term of the Sejm will, to be sure, be supported by the Constitutional Tribunal. Nevertheless, although this is an important and necessary institution, it would not be good for it to be overworked.

Another problem is the need to broaden and refine the system of science consultancy for the Sejm. And lastly, I believe that, during its Ninth Term, the Sejm should develop and refine the broad resorting to social consultation, to consultation of the opinions of citizens, that was initiated during the Eighth Term. I believe that the currently prepared draft of the decree on social consultation will, once it is passed, become in the hands of the deputies an important instrument for optimally adapting the Sejm's work to the social realities.

[Question] What conclusions have you, as a candidate for the Sejm, drawn from meetings with voters?

[Answer] The opinions of voters confirmed markedly what we had long been discussing at the forum of the Commission for Internal Affairs and Administration of Justice. Complaints about delays in judicial proceedings, the actions of court bailiffs, and sometimes the dilatoriness of local law enforcement bodies or the militia are being constantly repeated. I realize that these problems have to be urgently resolved, not just in individual cases but on a general scale.

A matter which gratifies me personally is the support for legislation that tightens the responsibility for particularly acute social crimes. Despite the apprehensions and doubts voiced during discussion of the related decrees, it turns out that the extent of social condemnation of these crimes and their perpetrators is so great that some voters have even objected that we have been too cautious and the solutions we adopted are too lenient. This fact serves to infer conclusions for the future. To wit, there is an urgent need to pay greater attention also to the protection of the personal and private property of citizens, to the protection of their personal safety. This also is a condition for law and order in this country. And lastly, various measures are needed to improve the public's legal knowledge. This is a major task for the future, and I believe that the Ninth Term of the Sejm will accomplish many signal advances in this respect.

1386

CSO: 2600/82

POLITICS

POLAND

PRE-ELECTION ACTIVITIES

National Electoral Commission Inspection

Warsaw TRYBUNA LUDU in Polish 25 Sep 85 pp 1, 2

[Interview with Jerzy Breitkopf, head of the State Electoral Commission Inspectorate, by PAP journalist Wojciech Kazimierczak: "Preparations for Elections Proceeding Correctly"]

[Text] The course of the preparations for the elections, in light of the investigations conducted by the inspectors of the State Electoral Commission [PKW], was the subject of an interview conducted by a PAP journalist with the head of the PKW Inspectorate, Jerzy Breitkopf.

[Question] What exactly is the Inspectorate of the State Electoral Commission?

[Answer] It is a group of people, appointed in accordance with the regulations of the State Electoral Commission, who conduct investigations of the correctness of the performance of individual activities resulting from the Electoral Law and the electoral calendar. We have 60 inspectors delegated to the State Electoral Commission from the central state institutions and suitably trained in the area of electoral law. So far we have conducted 5 inspections of the manner and timeliness of the performance of individual work associated with the elections. Reports on the results of investigations are presented to the State Electoral Commission, and comments and observations about occasionally occurring violations are forwarded directly to the district electoral commissions and the provincial electoral offices. This model was adopted by the district commissions and the provincial electoral offices, which appointed their own inspection groups. Independently of the inspections conducted by the inspectorate, the members of the State Electoral Commission went out into the field from 16 to 18 September in order to examine the work of the district and precinct commissions.

[Question] What specifically were the inspections devoted to?

[Answer] During the last inspections, at the beginning of September and in the middle of this month, we investigated, among other things, the correctness of the appointment of the precinct electoral commissions, the progress of the

training of the members of those commissions, the preparation of the electoral lists, and their display for public inspection.

[Question] What did the inspectors determine?

[Answer] The results of all the investigations conducted to date show that the preparations for the elections are proceeding correctly. The few irregularities uncovered by the inspectors were local in scope, and as a rule had to do with violations of an organizational-technical nature. Currently the defects have been eliminated.

In regard to the last inspection, for example, which had to do with the display of the electoral lists for public inspection, it confirmed the effectiveness of the activity of the precinct electoral commissions. The members of the commissions are not only fulfilling their obligations accurately and rigorously, but are also often undertaking -- together with the administrative bodies -- various types of steps to make the preparation of the lists easier for the electors.

The deadline for the display of the lists (15 September) was met in all the provinces. They are displayed for 5 hours a day, and in some parts of the country even longer. For example, in the Walbrzych province, the offices of the electoral commissions are open for 7 hours a day, in the Sieradz province, Gdansk, and Wejherowo 6 hours a day, and in Unislaw (Torun province) even 10 hours a day. In general the schedule of the hours for displaying the lists has been left to the decision of the precinct electoral commissions, while in some of the provinces it has been standardized. For example, in the capital province the lists can be checked from 14:00 to 19:00 on weekdays and from 11:00 to 16:00 on holidays. In the Katowice province, the lists are made available from 10:00 to 12:00 and from 15:00 to 18:00 every day. Care has been taken to make sure that the appearance of the offices where the lists are displayed is suitable. Telephone communications are provided to make it possible to check the correctness of the data without leaving one's home.

The residents of individual buildings and streets are informed about the addresses of the electoral offices and the hours when they are open. In the Konin province, institutional radio stations are used for this purpose. In Warsaw, a news flyer is printed, in an edition of 650,000, which is delivered by mailmen along with the mail. In the Lublin province, boy scouts help in informing the voters, and in the Gdansk province a special sign is printed about the rules for checking the lists. The head of the city and commune of Rzepin in the Gorzow province organized a special system for bringing the residents of remote localities to the voting precinct, in order to make it easier for them to check the correctness of the data contained in the lists.

It is worth noting that the lists will be displayed until 28 September, and if necessary even longer.

SD CC, PRON Meet on Elections

Warsaw TRYBUNA LUDU in Polish 25 Sep 85 p 2

[PAP article: "Members of the SD in the Electoral Campaign"]

[Text] The Presidium of the Central Committee of the SD [Democratic Party], at a meeting on 24 September, was acquainted with a report on the course of the electoral campaign for the 9th term of the Sejm.

The broad scope of the social consultation of the candidates for deputies was emphasized. The Presidium expressed a favorable view of the participation in the campaign of candidates representing the SD.

The meetings of the leadership of the SD Central Committee with the party's activists in PRON [Patriotic Movement for National Rebirth] were also assessed. These meetings, which took place in all of the provincial committees of the SD, permitted a discussion of the party's courses of action on behalf of national agreement, and the tasks associated with the last stage of the electoral campaign. During the meetings it was stated that the party is not treating the agreement as a one-time act, but considers it a process, the successful course of which is the best guarantee for protecting society and the state against further crises. This requires that the SD activists in PRON engage in the further active formation of this process, and that they bring the party's political-program tasks into it. It was emphasized that the basic problems, for the solution of which close cooperation between SD echelons and circles and PRON councils and cells is particularly indicated, are the following:

-- optimum utilization of the intellectual and scientific potential of the Polish intelligentsia, and creation of the proper living and working conditions for it;

-- equalizing access to the values of culture, and making it possible for all members of society to participate fully and actively in it;

-- ensuring that the sphere of small-scale manufacturing and trade has possibilities for the full utilization of production capacity and development, in accordance with social interests and the needs of the market;

-- systemic solutions and consistent actions serving to protect the natural environment in Poland.

The Presidium discussed the program for the day of the SD press and publications, which will be observed on 30 September 1985.

Veterans Appeal for Election Participation

Warsaw RZECZPOSPOLITA in Polish 26 Sep 85 p 2

[PAP article: "Appeal of Former Professional Soldiers"]

[Text] On [date illegible] September, a plenum of the Main Administration of the Union of Former Professional Soldiers [ZBZZ], devoted to a discussion of the union's participation to date in the Sejm electoral campaign, was held in Warsaw.

The plenum issued an appeal to the members of the ZBZZ for universal participation in the October elections. It will be a particularly significant political event in the life of our country, since it will confirm the political and socioeconomic changes that are taking place.

The plenum was also acquainted with the social-everyday problems of military retirees and pensioners. The documents for the Second National Congress of the ZBZZ, which will take place from 23 to 24 November, were adopted. Service General Antoni Jasinski, Vice Minister of National Defense and Deputy Minister of National Defense for general affairs, was present.

Police Fight Social Ills, Says Kiszczak

Warsaw RZECZPOSPOLITA in Polish 27 Sep 85 p 5

[PAP article: "Civic Responsibility"]

[Extract] The electoral campaign for the Sejm has been under way for several weeks now. What has been achieved in the meetings between the candidates for deputies and the voters is expressed in values that cannot be measured immediately, since this has to do with the growth of the civic feeling of responsibility for the country and the state, and with the ideological-educational dimension of the campaign, especially among the thousands of young Poles who will go to the polls soon for the first time in their lives. Here is a story from one of these meetings:

A pre-election meeting was held in Przemyśl, and was attended by the following: Service General Czeslaw Kiszczak, deputy member of the Political Bureau of the PZPR Central Committee and Minister of Internal Affairs, a candidate from the national list, and candidates from the district list. They met with the sociopolitical actif of the Przemyśl province.

At the same time, it was stated that both the electoral campaign for the people's councils and the present one have influenced a great deal of social activity, and mobilized the local authorities for effective realization of the postulates voiced.

Czeslaw Kiszczak noted, among other things, that in the first half of this year symptoms of a limitation on the growth of crime became evident in Poland. Several determining factors are occurring, however, that have a very

fundamental relationship with social pathology. Such phenomena as the social maladjustment of minors, drug abuse, alcoholism, and a parasitic way of life constitute ominous criminogenic factors and have a fundamental bearing upon the state of order and public safety.

The results of the militia inquiries show that a considerable number of the parasites obtain their means of support from crime. They constitute more than 20 percent of the established perpetrators of acts [word indistinct] with the law. The minister stressed that the civil militia are undertaking actions aimed not only at fighting the consequences of pathology, but also at eliminating their causes.

The minister called attention to the extensive participation of the militia in the social process of educating young people and taking care of children, in activities serving to protect social, private, and church property, and in identifying various irregularities earlier.

Army General Florian Siwicki, deputy member of the Political Bureau of the PZPR Central Committee and Minister of National Defense, who is a candidate for deputy on the national list, met with representatives of youth organizations in the Rzeszow province. For several hours, Kazimierz Barcikowski, secretary of the PZPR Central Committee and member of the Political Bureau, a candidate for deputy on the national list, conducted a lively dialogue with foremen from all of the departments at the Lenin Steelworks and with representatives of mid-level technical supervision from other large plants in the Krakow metropolitan area. Deputy Premier Zbigniew Messner, a member of the Political Bureau of the PZPR Central Committee and a candidate for deputy on the national list, met with management personnel from Warsaw industry in a pre-election meeting.

#### Election Lists Checked by Voters

Warsaw TRYBUNA LUDU in Polish 30 Sep 85 p 5

[Article by (lem): "Checking of Election Lists Continuing"]

[Extract] (Our own information) Lists of voters have been displayed since 15 September in all of the electoral districts. In accordance with the regulations of electoral law, these lists have been made available for inspection for 14 days. This means that another 3 days remain for checking on whether we are included in the list of voters and whether our personal data is written correctly.

It should be noted that checking the list is not an obligation of the voter. It has vital significance in practice, however, since it allows eliminating irregularities in the list and casting a vote without any problems on the day of the elections.

Extension of Election List Check

Warsaw ZYCIE WARSZAWY in Polish 30 Sep 85 p 4

[PAP article: "Lists of Voters Until 6 October"]

[Text] Taking into consideration the systematic increase in society's interest in the election campaign for the PPR Sejm, and also in order to make it possible for those voters who have not yet been able to check their names on the lists of voters, the electoral commissions in Warsaw and the capital province adopted a decision to extend the period for displaying the lists of voters through 6 October inclusive.

The lists of voters are displayed for public inspection in the offices of the Precinct Electoral Commissions from 14:00 to 19:00 on weekdays (and also on Saturday), and from 11:00 to 16:00 on Sunday.

OPZZ Committee on Pre-Election Meetings

Warsaw TRYBUNA LUDU in Polish 30 Sep 85 p 4

[Article by (dan): "Proceedings of the Executive Committee of the OPZZ"]

[Text] (Our own service) The members of the Executive Committee of the Nationwide Agreement of Trade Unions [OPZZ], who met on Saturday (28 September) in Warsaw, dwelt on the conclusions derived from the consultative meetings associated with the elections for the Sejm.

As we know, the candidates recommended by the trade movement participated in these meetings. It took an active part in the election campaign, viewing the existence of a group of union deputies as one more possibility for obtaining influence upon the solution of important social problems. In the first phase of the election campaign, the lists included 126 union activists as candidates for the Sejm. The trade movement also took an active part in organizing the meetings and delegated its representatives to the electoral conventions. The union candidates for deputies, 103 of whom currently remain on the lists, also participated in the meeting on Saturday. As stated by Zbigniew Cierpka, the deputy chairman of the OPZZ, the meetings held thus far, rich in social topics, constitute an object for analysis of the trade movement. The issues raised by the voters, sometimes apparently local ones, often form part of a certain whole and demonstrate the occurrence of various shortcomings throughout the country. This has to do, for example, with environmental protection and the shortcomings of the communal economy (both in the cities and in the villages), the supply of the market, and also housing construction.

"We have been convinced," testified Alfred Miodowicz, the chairman of the meeting, "that a great deal is expected of our movement in the near future, and also from its future representation in the Sejm. People are particularly counting on the wage system being straightened out, due to the institution of collective contracts. It is known that the chances of sending the Sejm the text of a law coordinated with the government are slight," the chairman of the

OPZZ stated. "The role of future union deputies, who have to defend the positions of the trade movement, will be even greater. Solutions dealing with the creation of social and housing funds at plants are important. There are also discrepancies in assessing the proposals presented. Other important subjects have to do with social insurance and improving the situation of retirees and pensioners, and housing construction and protection of the substance already in existence. These are to some extent key problems, on which the work of both the union organizations and the group of union deputies in the Sejm should be concentrated."

At the end of this point in the meeting, the Executive Committee of the OPZZ sent a message to the union members, speaking of how the trade movement, in its program activity, should take into account the conclusions and proposals presented during the election campaign. The future deputies recommended by the unions are obligated to make efforts to realize the aspirations of the voters. Through the deputies, the voters hope to obtain influence on the preparation of suitable legal documents and on decisions affecting the vital interests of working people. The members of the OPZZ call upon all union members to participate actively in the election campaign and in the elections.

Another subject of the meeting of the OPZZ Executive Committee was the issue of accepting sponsorship for schools. Prof. Zbigniew Gertych, the chairman of the National Committee of the People's Action to Assist the Schools, who was present at the meeting, described the needs of schools in Poland and justified the necessity of supporting the efforts of the state through social activities, especially in the area of the construction of schools and preschools. This has to do with increasing the number of places in these institutions, and especially with liquidating the lack of stability in teaching that is so troublesome for teachers, pupils, and parents. Material assistance from the sponsoring organizations would also be desirable. So far a hundred plants have shown interest. The participation of other economic units and social organizations is thus being counted upon. The issue of the OPZZ's accepting sponsorship for schools will be raised again at the next session of the Executive Committee, when its members will be acquainted with the projects for activities that have been presented.

A delegation from the Sandinista Workers' Center, with secretary general Lucio Jimenez Guzman, also took part in the Saturday meeting. He reported on the situation in his country and the threats that are occurring. He stated that the trade movement in Nicaragua counted upon the support of Polish union members.

#### OPZZ Comments on Union Candidates

Warsaw TRYBUNA LUDU in Polish 30 Sep 85 p 4

[Article by Teresa Grabczynska: "Meeting of the OPZZ Executive Committee"]

[Excerpt] Who are the union candidates for deputies? Most of them are workers and technicians -- 52 people; the group of candidates also includes, among others, 8 teachers and 5 doctors. One-fourth of them are women. Only 7

people serve as the chairman of national organizations, and plant activists are in a definite majority.

Sharing their opinions and observations, the candidates for deputies pointed out, among other things, that a conviction has become established in public opinion concerning the need for the stabilization of law, for the 9th term of the Sejm to concentrate on implementation of the laws already adopted, and for exercising its supervision authority more fully. The essential problems facing it are the survival instinct [samowyzwienie] of the people, the improvement of housing construction, and more effective environmental protection.

A delegation from Nicaragua's Sandinista Workers' Center (CST) also participated in the first part of the session; its secretary general, Lucio Jimenez Guzman, reported in a brief speech on the situation in his country and the patriotic struggle of the people against American imperialism, and he called for international workers' and union solidarity.

The traditions of trade unions in the movement for sponsoring schools were also mentioned during the meeting on Saturday.

[Separate PAP article]

On 28 September, there was a meeting between Alfred Miodowicz, chairman of the OPZZ, and Wincent Lewandowski, deputy chairman of the PRON National Council, devoted to the current situation in housing construction and the tasks in this area. As it appears from the communique published after the meeting, both OPZZ and the PRON National Council are the targets of society's demands and expectations, and at the same time, of dissatisfaction with the state of housing construction thus far. Attention is called to the poor organization, failure to use reserves, and lack of sufficient coordination of the efforts of the entire national economy in support of housing construction.

#### Journalists' Sociopolitical Duties Discussed

Warsaw RZECZPOSPOLITA in Polish 1 Oct 85 pp 1, 5

[PAP article: "Not in Words, but in Deeds"]

[Excerpt] Throughout the entire country, meetings are taking place between the voters and the candidates for deputies. Each of the candidates has already come at least 8-10 times before representatives of various professional and social circles.

The discussion accompanying these meetings indicates the general expectation of all the participants that patriotism and concern for the future of the country will point out in the final analysis an effective means of resolving social difficulties, and that the joint effort of the people will pay off in increasing understanding. Both the voters and the candidates for deputies are coming out of these difficult and sometimes critical talks with the conviction that the outcome of the pre-election debate will be a factor inspiring the

future Sejm to more work on fulfilling social expectations, in both the political and economic spheres.

It is being emphasized in many meetings that it is no longer a question of major decisions on matters of state, but rather of social agreement also increasing in regard to people's everyday affairs, and of action everywhere that conditions and opportunities for it exist -- not in words, but in deeds.

Here are several stories from these meetings:

Public opinion is a sensitive barometer, whose indications are not disregarded by the authorities. A journalist who wants to play the proper role of a sort of intermediary in this dialogue also cannot allow himself to do so. This opinion, stated by Marian Butrym from the RAZEM editorial staff, along with other statements related to the political culture of society and the conditions for engaging in the profession of journalism, was the beginning of a discussion at the Warsaw Journalists' House. The participants in this discussion, along with Deputy Premier Mieczyslaw F. Rakowski, a candidate from the national list, were the following journalists from Warsaw seeking a deputy's mandate: Witold Lipski, the chief editor of WIES WSPOLCZESNA, Ryszard Lukaszewicz, the chief editor of EXPRES WIECZORNY, Waldemar Krajewski, the chief editor of REDAKCJA SPORTOWA TV, Ryszard Wojna, a RZECZPOSPOLITA commentator, and Jozef Wojcik, the chief editor of SLOWO POWSZECHNE.

As in many professional circles, among the journalists of the press, radio, and television there are also problems, whose solution would make the circulation of information more efficient, help raise the level of journalism, and ensure the desired influx of young personnel. Therefore -- in the opinion of editor Halina Kucharska of Polish Radio -- the future Sejm should consider the possibility of creating, in the Commission for Culture, a subcommission that would deal with all the problems of the functioning of the mass news media. This applies to both close cooperation with the recently formed Press Council, and to watching over the implementation of the decisions contained in the press law, the development of the printing and technical base, etc.

Individual speakers, in their speeches, recalled the essence of the conclusions presented during the meetings in the electoral campaign. R. Wojna considered the main motif of all of the pre-election discussions to be, as he put it, society's great longing for the government to organize people's work better. R. Lukaszewicz agreed with this opinion, but added, however, that demanding an efficiently functioning state often coincides with those making the demand avoiding responsibility in their "own" sector of work. This also happens among journalists -- fortunately, in isolated cases. Ryszard Badowski from television, Leszek Blaszczyk from ZAGIEL, and Andrzej Ziemiński from ZYCIE WARSZAWY, among others, called attention to the material and social conditions for work in these circles, and to the need to improve them. They proposed the improving the functioning of the printing industry without investments. It is necessary to analyze and modernize the organization of labor in printing, and the system for newspaper distribution, which often causes considerable delays in getting them to the readers, since, just as in radio and television, one can only count on an improvement in the equipment of printing plants and

modern machinery when more urgent needs, requiring foreign exchange means of payment, have been satisfied.

The theme of the social role of journalists was also stressed in the speeches; in the opinion of W. Lipski, for example, they should contribute to raising the level of political culture and the state of legal knowledge in society. Among the conclusions that came from both the discussants and the candidates for deputies, many dealt with educating the awareness of the younger generation. J. Wojcik, for example, stated that the campaign under way, the meetings with the candidates, and also the reflections of this campaign in the press are an occasion for young people, who are often reluctant to take part in a dialogue, to engage in it. One must, however, as is not always done, try to get through to them by speaking the language of concrete facts and offering answers to even the most difficult questions.

#### Too Few Lawyers as Candidates

Warsaw RZECZPOSPOLITA in Polish 1 Oct 85 p 5

[PAP article: "Out of Concern for the Quality of Laws"]

[Text] Judges, prosecutors, counselors, lawyers, and other representatives of the legal professions met on 30 September 1985 in Warsaw with the lawyers who are candidates for deputies: Andrzej Kalwas, the dean of the District Chamber of Legal Counselors, Zygmunt Surowiec, the chairman of the Sejm's Commission for Internal Affairs and the Administration of Justice during the last term, and Sylwestr Zawadzki, the chairman of the Legislation Council. The organizers of the meeting were the Provincial Administration of the Association of Polish Lawyers and the Warsaw Council of the Patriotic Movement for National Rebirth.

Many speakers argued that too few lawyers were candidates for the PPR Sejm, which could have an unfavorable effect upon the quality of the legislation created by it. It was even proposed that the authority provided by article 65 of the electoral law should be exercised and that Andrzej Kalwas should be transferred to the mandate position.

#### Journalist-Candidate On Campaign, Duties

Warsaw DZIENNIK LUDOWY in Polish 26 Sep 85 p 4

[Interview with Ryszard Lukasiwicz, chief editor of EXPRESS WIECZORNY and candidate for the PPR Sejm, by Marta Peciakowska: "Sometimes Better to Say Less"]

[Excerpt] You asked for my reflections. I will not conceal the fact that both the high attendance by voters and their activity at every meeting have been something of a surprise for me. I did not think that several hundred people would want to engage in a discussion with such fervor and enthusiasm for several hours, and finally after a day of work. It was obvious that the

voters do care about who will represent them in the Sejm. They interrogated us, the candidates, severely. They forced us to compete. The ones who were not able to defend their positions skilfully did not win approval. That was clearly felt.

Another reflection has to do with the problems pointed out at the meetings. As everywhere, local or regional issues were dominant, but they were discussed in the context of national issues. I admit that the talks and the meetings with the voters allowed me to become considerably more familiar with the problems of the area that I will possibly represent. I filled up a thick notebook.

Honest journalism combines the elements of scientific knowledge with operational and socially beneficial use of it. Furthermore, journalism is a political profession; a journalist must represent the side of society, but also try to understand the side of the government. And since these sides are not always consistent, we journalists often experience internal conflicts. My personal view is that sometimes it is better to say less, but honestly, than to say nothing.

#### Plato's Vision of Authority Figures Favored

Warsaw ITD in Polish No 38, 22 Sep 85 p 2

[Letter from Wieslaw Wyrzykowski: "Before the Elections"]

[Text] A wise man, Plato, in his reflections on "The Republic," stated that authority should be exercised by philosophers, educated people, wise men. A soldier should fight and guard the borders, a farmer should be engaged in cultivating the soil, etc.

What am I driving at? I observed the course of the pre-election campaign, and I listened to the meetings of candidates after candidates. They represented all circles and professions, the difference in ages was enormous, and the education ranged from elementary on up.

Such a form does not suit me; I am an adherent of Plato's model, in which authority is concentrated in a group of philosophers, people with enormous experience and knowledge. I respect work and effort, and the dedication of farmers, workers, etc., but... After all, the Sejm is a legislative body, and thus our future, our tomorrow, is in its hands. And what qualifications will the future deputies possess?

Plato was an idealist, and no one picked up on his idea, so my modest voice has no significance -- but what if we did give authority to wise men?

9909  
CSO: 2600/47

POLITICS

POLAND

PROPOSED CHANGES IN CENTRAL ADMINISTRATION

Warsaw TRYBUNA LUDU in Polish 8 Nov 85 pp 1, 5

[Article by PAP: "Proposals for Changes in the Structure of State Administration Organs;" passages in slantlines printed in boldface]

[Text] /Meeting under the leadership of Sejm Delegate Marian Wozniak (PZPR) on the seventh of this month, the Special Parliamentary Commission reviewed the tabled government plan for a law on changes in the organization and in the range of activity of some chief and central organs of the state administration./

The proposed law--as the outgoing premier, General of the Army Wojciech Jaruzelski stated in his letter sending it to the Sejm--encompasses rules and creates conditions which would make possible more efficient and effective solutions to many important social and economic problems by concentrating them on a central level within the reach of uniform, compact organizational structures to deal with matters closely connected to each other.

/According to the said plan, the following new offices would be established: a Ministry of Building and Spatial and Municipal Management/--which would join what had hitherto been the range of activity of the minister of Building and Building Materials Industry with that of the minister of Spatial Administration and Management--which would serve, among other things, to intensify apartment building, simplify the acquisition of land for its needs and ensure a better economy for housing resources;

/--an office of the minister of Agriculture, Forestry and Husbandry/--encompassing the range of activity of matters hitherto lying within the jurisdictions of two separate ministers; this concerns, among other things, the integration of economic activities connected with the use of lands and their preservation. The intention is to retain the present internal structure of the state forest administration and to relegate the secondary and special processing of forest raw materials to the management of the minister of Chemical and Light Industry;

/--an office of the minister of Environmental Protection and Natural Resources/--encompassing the range of activity of matters with which the

Department of Environmental Protection and Water Management and the Central Office of Geology had hitherto been concerned. This would mean a concentration of jurisdiction in the sphere of identifying, gathering information on and protecting natural resources and the natural environment. The plan provides for the appointment of one of the country's top geologists;

/--a Ministry of Material and Fuel Management,/ for the range of activity of matters which were hitherto governed by the minister of Material Management and the Chief Inspector of Energy Management; the latter position would be kept not as an office, but as an individual subordinate to the minister.

/The law also provides for the liquidation of the Ministry for matters concerning Prices and the relegation of matters which were hitherto encompassed within its range of activity to the minister of Finance--which should favor more efficiency and effectiveness in the use of economic tools in the functioning of economic entities./

Another change proposed in the plan is the union of the Main Committee on Physical Education and Sports with the Main committee on Tourism; as it is stated in the plan's justification, the separation of these two committees has not confirmed its serviceableness, as the plan's justification states.

Finally--in conjunction with proposed abolition of the Ministry of Spatial Administration and Management--the present tasks of the regional administration would be relegated to the minister--the chief of the Office of the Council of Ministers.

The plan for the law also transfers matters of urban transport and roads, hitherto encompassed within the range of activity of the minister of Spatial Administration and Management, to the jurisdiction of the minister of Transport, and it proposes to turn over supervision of the houses of sobriety to the minister of Health and Social Welfare. The plan also makes it possible for the Council of Ministers to create the positions of state secretaries or government plenipotentiaries to assure the legally uniform realization of the social and economic tasks, which are separate in detail.

/In the discussion the delegates universally approved the plan for the law set before the Sejm, emphasizing that it has become the next step in the improvement of the structure of the state administration./

At the same time an array of doubts, questions and particular proposals concerning the placement of concrete problems within the jurisdiction of individual ministers, were expressed, but they were cleared up in the course of the discussion. The delegates devoted much of their attention to the proposed liquidation of the Ministry of Prices, the Office of Prices and the regional offices of prices. The taking over of matters hitherto lying in their ranges of activity by the department of finances and the treasury houses ought to favor--it was said--a new form for the office of the minister of finances as an organ of the state finance policy. But attention was also drawn to the fact that in practice the excessive concentration of jurisdiction is not always effective in practice. Much time was also devoted to the position of the land surveying services, their role and tasks. The delegates

fully showed that the plan for the law conforms to the demands of the electorate, and at the same time sets the organizational structure within the state administration in order and is in keeping with the principles of economic reform.

/The deputy secretary of state in the URM [Office of the Council of Ministers], Zygmunt Rybicki, offered an explanation. Among other things he stressed that the proposed changes serve to simplify the structure of the State's central administration and finds economical forms for its activity./ Engaging in polemics with the prevailing opinion on the superfluity of personnel in this administration, he indicated that in Poland there are 36 state administrative workers for every ten thousand inhabitants, and thus significantly less than, e.g., in Bulgaria or East Germany, the proposed changes would result in a lessening of administrative workers by about two percent; careful scrutiny of the number of personnel would accompany the enactment of the proposed law and the joining of departments and offices. The proposed law--Z. Rybicki maintained--does not touch the structure of the regional administration, such as agriculture, forestry, etc.

/The commission, after the introduction of corrections, approved the plan for a vote, which will take place in the House on the twelfth of this month -- at the next session of the Sejm./

12972

CSO: 2600/131

POLITICS

POLAND

### NEW SEJM COMMITTEES DRAWN UP

Warsaw TRYBUNA LUDU in Polish 11 Nov 85 p 2

[Passages in slantlines printed in boldface]

[Text] The daily agenda of the second session of the Sejm included the following point: "the election of standing Sejm committees." In the communique published Friday from the first session of the Rules and Mandates Committee we can see that they were also engaged in a plan for changes in the rules of the Sejm in conjunction with proposed changes in the committee structure./

Committees fulfill an important role in the life of the Sejm, they are the principal medium of parliamentary activity--they consider plans for laws and resolutions, they work out the position of the Sejm on particular matters, and they are important media for parliamentary control over the organs of the administration.

At the end of the seventh term there were 20 committees--two less than at the beginning, in 1980. Many changes are hidden behind this apparently slight revision. That Sejm appointed three new committees (Complaints and Suggestions, Constitutional Liability and the Committee on matters concerning Workers' Self-Rule). In addition it introduced an array of other changes, which consisted primarily of changing the committees from a department configuration to a problem configuration. For example, several "branch" committees were replaced by one Trade Committee, problems of social policy, health and physical education were united into one committee, etc. In this way 17 committees remained of the original 22, which together with the three new committees gives us the number 20.

The Sejm of the seventh term did not consider these changes definitive, but rather an outline of /a certain direction toward loosening the committees' ties with the structure of the departments, and they thought that it would be necessary to analyze the applicability of the new solutions and perfect them if needed./

At the beginning of its term we do not know what what sort of changes the new Sejm wants. However, because in the last term they had clearly identified certain social and economic problems as important for today and the near future, we can assume that these will be the subject of the Delegates' deliberations.

POLITICS

POLAND

PROVINCIAL DELEGATE MEETINGS IN SEJM

Warsaw RZECZPOSPOLITA in Polish 11 Nov 85 p 5

[Article by PAP: "Inaugural Session of the Provincial Delegate Meetings;" passages in slantlines printed in boldface]

[Text] /The consecutive provincial delegate meetings are underway. The guiding principle of their creation is the concept of maintaining as close a contact as possible between the members of parliament and the electorate and their problems./

The Provincial Meeting of Delegates held its inaugural session in /Poznan/. The delegates, after a discussion, adopted rules of operation and established a format and a plan of activity for the problem groups, which will be engaged with individual sets of questions. For example, one of the groups will be engaged in the analysis of the suggestions and demands expressed by the citizens during the election campaign and will evaluate their implementation.

A Provincial Delegate Meeting was also held in /Olsztyn/. At the first session the terms of the delegates' duty were established, in the course of which the residents will be able to express their pervasive concerns. It was decided in November to begin meetings with the electorate. At the inaugural session of the meeting the course for handling the suggestions expressed in the pre-electoral meetings was also discussed.

12972  
CSO: 2600/131

POLITICS

POLAND

NEW CENSORSHIP PROCEDURES IN STATES OF EMERGENCY

Warsaw MONITOR POLSKI in Polish No 17, Item 140, 17 Jul 85 pp 167, 168

[Order of the president of the Main Office for Control of Publications and Entertainments, S. Kosicki, on the Procedure for Issuing Licenses for the Use of Printing Establishments and Devices and Apparatus Producing Seals and Stamps in the Period of a State of Emergency, of 18 February 1985]

[Text] On the basis of article 16 paragraph 4 of the law of 5 December 1983 on the state of emergency (Official Gazette No 66, item 297), in accordance with the President of the Council of the State, the following is ordered:

Article 1. 1. The use of machines and devices through whose aid printing activity is conducted, as defined in article 1 of the decree of the Council of Ministers of 20 August 1984 concerning the specific rules for the distribution of licenses, registrations and controls for printing businesses, establishments and devices (Official Gazette no 40, article 213), hereafter referred to as "the decree," and the use of devices and apparatus creating recordings of pictures, words and sounds in any fashion with the aim of public distribution, and also the operation of establishments which create seals and stamps--in an area in which a state of emergency has been put into effect due to a threat to the internal security of of the state--requires the acquisition of a separate license, regardless of any licenses already held.

2. The license, mentioned in paragraph 1, will be issued by the appropriate district office for control of publications and entertainments.

3. If the license concerns establishments, devices or apparatus which will be in the possession of state or cooperative organizational entities, that license will be issued by the appropriate minister, the chief of the central office, the governor (the mayor of the capital city of Warsaw, the city of Lodz, the city of Cracow) or the president of the headquarters of the appropriate cooperative union.

Article 2. 1. The license will be issued on the application of the concerned individual or organizational entity.

2. The application for issuance of a license should include data defined in article 3 paragraph 2 points 1, 2, and 4-6 of the decree, and in addition

define the security of the establishment, machines, devices or apparatus against access by unauthorized persons. In the application data must also be provided concerning the persons responsible for the suitable security of the printing machines and devices and the supervision over the legality of the execution of work.

3. The regulation in paragraphs 1 and 2 applies correspondingly to an application for granting a licenses for the use of devices and apparatus creating recordings of pictures, words and sounds in any fashion with the aim of public distribution and also the operation of establishments which create seals and stamps.

Article 3. 1. The organs mentioned in article 1 paragraphs 2 and 3 can grant a license after making certain that the use of the printing machines and devices or the apparatus creating recordings of pictures, words and sound or the operation of the establishment creating seals and stamps will not threaten the interests of the security of the state.

2. The organ mentioned in article 1 paragraph 3 will immediately send a copy of the license to the appropriate district office for the control of publications and entertainments.

Article 4. The license mentioned in article 1 paragraph 1 should contain:

- 1) the name and address of the applicant,
- 2) the address of the establishment or the location in which the activity is to be conducted,
- 3) a definition of the nature of the activity.

Article 5. 1. The organs granting the licenses, the founding organs of the businesses, the directors of these businesses and the cooperative administrations of the organizational entities are under an obligation in a period of a state of emergency to perform systematic supervision and control over the use of the establishment, devices and apparatus defined in article 1 paragraph 1.

2. The obligation mentioned in paragraph 1 also applies to the organs of the state administration which supervise the organizational entities which are not businesses and on the persons managing these entities.

Article 6. 1. The owner and user of the establishment, devices and apparatus, defined in article 1 paragraph 1, who does not have a license for conducting activity during a state of emergency, is under an obligation at the moment of the introduction of that state to immediately stop further use of the equipment and to secure the establishment, devices or apparatus.

2. In the event of the ascertainment of the use of an establishment, devices and apparatus defined in article 1 paragraph 1 without the license required or in defiance of its conditions, the organs for the control of publications and entertainments and other appropriate organs can make use of the means and

activities foreseen in article 16 paragraph b3 of the law of 5 December 1983 on the state of emergency (Official Gazette No 66 item 297).

Article 7. 1. The governors and the mayors of the capital city of Warsaw, the city of Lodz and the city of Cracow are under an obligation from the moment the state of emergency is declared to immediately present to the appropriate district office for the control of publications and entertainments a register of devices, apparatus and establishments creating seals, which register is mentioned in article 9 point 3 and article 13 paragraph 2 of the decree.

2. The district office for the control of publications and entertainments, after receiving the register mentioned in paragraph 1, can call in the concerned party to submit an application for a license for the further operation of the establishment or the use of the apparatus and devices. The rules of article 6 apply correspondingly.

Article 8. This order goes into effect on the day of its announcement.

President of the Main Office for the Control of Publications and Entertainments: /S. Kosicki./ [In italics]

12972

CSO: 2600/131

POLITICS

POLAND

PRESS, JOURNALISTS FEATURED

New TRYBUNA LUDU Editor Named

Warsaw ZYCIE WARSZAWY in Polish 14 Nov 85 p 2

[PAP item: "The Imminent Tasks of TRYBUNA LUDU"]

[Text] According to a resolution passed by the 22d Plenum of the Central Committee, a joint meeting of the editorial board and of the executive committee of the basic party organization at the PZPR Central Committee's organ TRYBUNA LUDU, was held on 13 November, to mark the assumption of the newspaper's editor-in-chief duties by Jerzy Majka.

During the meeting, Jan Glowczyk, alternate member of the Politbureau and secretary of the PZPR Central Committee, conveyed best wishes to Jerzy Majka for fruitful work at his responsible function for the benefit of the party. At the same time, the secretary thanked the former editor-in-chief, Wieslaw Bek, for his many years of active work in running the PZPR central organ.

During the meeting, in which Bogdan Jachacz, head of the press, radio and TV department of the Central Committee, also took part, the oncoming tasks of TRYBUNA LUDU were also discussed.

New Journal

Warsaw ZYCIE WARSZAWY in Polish 14 Nov 85 p 2

[Article by (eb): "The New Journal REPORTER"]

[Text] Readers are getting a new journal, titled REPORTER and published by the Polish INTERPRESS Agency. Its aim is to present events throughout the country and the world in form of journalistic reports--a genre well-liked but recently rarely available in our daily and weekly newspapers. To judge by the first issue, devoted entirely to reports on international affairs, the editors have managed to attract first class writers, including Junusz Rolicki, Alicja Basta, Wojciech Pielecki, and to present genuinely up-to-date subjects.

Thus one can find there a "Report on the Earthquake in Mexico City," an article which deals with the fight against famine in Ethiopia, and reports from India and Lebanon. The texts are accompanied by excellent pictures.

Unfortunately, neither the graphic layout nor the quality of newsprint of the new journal are impressive. REPORTER however has made a successful start, and the first issue encourages interest in those to follow. By then, one would like to find there equally up-to-date, interestingly written reports from Poland as well.

#### Information Access, Press Law Discussed

Warsaw TRYBUNA LUDU in Polish 15 Nov 85 p 2

[PAP item: "Press Law in Practice"]

[Text] Implementation of the press law, problems of journalist access to sources of information, effectiveness of press critiques, functioning of the institution of corrections and recidifications provided for in the law, as well as various aspects of journalist and editorial board's responsibility--were discussed on 14 November at a plenary session of the main board of the PPR Journalists' Association.

Jozef Krolkowski, chairman of the press council, pointed out that the practical implementation of the press law regulations has underpinned two essential principles: the duty of the administration and of other [public] bodies to make information available to the press, and to react to critical media publications. Even though no drastic cases of denial of information to journalists have been registered recently, journalists frequently encounter major difficulties in gaining access to enterprises and various institutions, those in particular which are prone to economic or organizational troubles.

Jerzy Urban, the government's spokesman, also dealt with the problems under deliberation. He said that according to the principle favored, the administration in its decision making should foresee its social resonance. If it disagrees with media appraisal, it should engage in polemics and present its own rationale in a proper way. In such cases journalists should be properly informed about the decisions made: they should be assured of presence at the nitty-gritty of the decision making. While the principle is generally observed at the central level, Jerzy Urban said, it sometimes falls short when lower-level authorities, work-places, and enterprises are concerned.

Bogdan Jachacz, head of the press, radio and TV department in the PZPR Central Committee, will also participate in the discussion, which is due to continue on 15 November.

#### Bloc Journalists on Peace, Defense Role

Warsaw TRYBUNA LUDU in Polish 20 Nov 85 p 2

[Own correspondent's and PAP reports: "The Journalists' Role in Strengthening Security and Defense: International Conference in Warsaw"]

[Text] An international conference of journalists from socialist countries who cover problems of patriotic and defense education, has begun in Warsaw. Delegations of journalists' clubs and sections from Bulgaria, Czechoslovakia, GDR, Romania, the Soviet Union, and Poland are participating in the meeting. The

debates are focused on the journalists' role in promoting security and defense of the Warsaw Treaty states in face of current threats.

On 19 November the conference participants laid flowers at the Unknown Soldiers' Tomb and at the Memorial Mausoleum of Soviet Army Soldiers. At the Polish Military Museum, where memorabilia of the traditional comradeship-in-arms between the Polish Army and the Soviet Army and other armed forces of socialist states are exhibited, they were told about our nation's contribution to the victory over Nazi fascism.

The debate was chaired by Wieslaw Bek, vice-chairman of the Main Board of the PPR Journalists' Association.

Brigadier Prof Leslaw Wojtasik, deputy head of the Main Political Directorate of the Polish Army, welcomed the participants, stressing, inter alia, the importance of permanent explanatory work, directed at shaping the defense awareness of public opinion.

The lectures pointed out that the journalist communities are able in their everyday work to contribute significantly to a "turn for the better in the situation in Europe and throughout the world," above all thanks to their activity to promote stronger solidarity and unity of the socialist states, which share an interest in the peaceful construction of socialism and communism.

The journalist communities' involvement in the patriotic and historical education of the younger generation was also discussed, alongside with acquainting public opinion in their respective countries with the threats posed by the development of mass-destruction weapons and the armament race stepped up by the United States and by NATO, as well as with the role the Federal Republic of Germany plays in creating tensions in Europe. Major attention was also paid to exchange of journalistic experiences concerning the modes of presentation by mass media of the armed forces of the socialist states.

The debate is continuing.

A conference of representatives of press organs of defense and sport organizations in the socialist countries, initiated and organized by the Main Board of the Country Defense League [LOK], began in Warsaw on 19 November. During the debate, the principles of cooperation between LOK and other defense organizations in promoting the comradeship-in-arms were discussed, and experiences were exchanged about their patriotic and defense activities.

On the first day, the conference participants--Col Dymitr Dikov of Bulgaria, Emma Sigeti of Hungary, Luis Maura of Cuba, George Dumitrescu of Romania, Purewdorzijn Baataarchauu of Mongolia, Col Werner Eltze of the GDR, Col Nicolai Bielous of the Soviet Union, and Lt Col Frantisek Hutka of Czechoslovakia--talked about the role and duties of their journals and of media in the patriotic and international education of public opinion.

General Zygmunt Huszcza, chairman of the LOK Main Board, took part in the conference.

12485/8309  
CSO: 2600/154

POLITICS

POLAND

LABOR, UNION ISSUES FEATURED

OPZZ Hosts International Energy Unionists

Warsaw TRYBUNA LUDU in Polish 14 Nov 85 p 5

[Text] Consultations concerning the establishment of an international association of trade unions of power engineering industry workers, were held in Warsaw on 12 and 13 November. Representatives of leading bodies of trade unions in the power engineering industry in the Soviet Union, the GDR, and France participated. Alfred Miodowicz, OPZZ chairman, met with union representatives from these countries, with Jan Nemoudry, secretary of the World Federation of Trade Unions, and with Alain Simone, secretary-general of the International Miners' Organization. Members of the OPZZ leading bodies took part in the discussion.

Quality of Party Worker Discussed

Warsaw TRYBUNA LUDU in Polish 18 Nov 85 p 3

[Article by Teresa Grabczynska: "The Party and the Unions: The Goals Are Shared Because They Are Workers' Goals"]

[Text] Is a non-party trade unionist just as good a trade unionist as his colleague, member of the party? We pose the question not because of theoretical considerations, but on account of practical cooperation between trade union and PZPR organizations.

The answer, as I see it, is as follows: Both trade unionists are in no way different as far as their rights and opportunities for action conforming to the law and the trade union statutes are concerned; in their duties, however, there is a difference. More responsibility is expected from those who abide by party discipline; those who do--or who at least should--play the role of a link between party and union organizations. We expect them to propagate wisely the party line among workforces, and to raise major workforce concerns at a party forum.

And how does it look in everyday life? In various workplace organizations' feelings and experiences tend to vary. In some of them one can easily find examples of party inspiration and support for union activities. I noted many cases, for instance, in the area of housing construction or leisure management.

But there are organizations which rate much lower; at best, one can talk about some improvement in their mutual relationship, and that is definitely not enough to fulfill sooner and better the expectations of the working people.

Similar conclusions were also indicated at the theoretical and practical conference, "The party and the trade unions," held recently under the aegis of the Academy of Social Studies, the Socioprofessional Department of the PZPR Central Committee, and the Center for Trade Union Studies. It was a first attempt to look at their relationship, to evaluate its state and ongoing changes, and to point out the surviving weaknesses or shortcomings.

The trade unions (by now they have some 5.6 million members) clearly have strengthened their position in the working communities, and have penetrated deeper into the various mainstreams of their lives.

They have just begun their full scale activities, free from organizational, programmatic, or jurisdictional problems. They are aware that they alone are responsible for their future progress. Specific social and economic concerns and expectations of workforces, involving circumstances of their own enterprises and industry branches, thus combine with trade union initiatives and efforts, fairly frequently giving rise to conflict situations. In such cases all the shortcomings and inadequacies of everyday practical life are faithfully mirrored.

Among trade unionists the expectation that party organizations would not cease to support them in their defense of workers' interests, nor to protect them against management encroachments, has become more general. In case they would have to confront the management, [they expect] the party to serve as an indispensable and just moderator.

Unlike some conference participants, I would tend not to pay such great attention to a certain routine ceremonial in the mutual relationship between the party and the unions. Is it really all that important, who should be the first to set a good example, or to inaugurate valuable initiatives? Or else, is the party's impact on the unions better, while vice versa perhaps less so? Joint sessions of [party] executive bodies and union boards, calculations how often and where such meetings should take place, and what should be their character, deliberation whether the unions should prefer encouragement of labor emulation, or--for instance--housing construction by enterprises, will bring no breakthrough.

Unease, especially on the part of PZPR bodies, is more justified, and often suggests unsatisfactory cooperation between trade unions and labor management.

Such cooperation does not have to be smooth and free of clashes, because there is no easy way to reconcile wage and social demands of workforces with the economic capabilities of the enterprises. But violation or obviation of the lawful rights of trade unions breeds concern.

What does it mean, after all, that in one half of the enterprises inspected by the Supreme Audit Chamber, union rights were not fully respected? It is no

secret, that in this way the management gains easier life, that--whenever possible--it eagerly "forgets" to ask for opinion or to seek agreement of union representatives, even in questions as obvious as disciplinary punishment, termination of employment contracts, or setting up principles of employees' premiums and benefits.

The cases of avoiding consultation of enterprise economic plans, ignoring not all that numerous but most useful suggestions by unionists concerning improvement in work organizations or in product quality, amount to virtual paradoxes.

No one can claim those are concerns of trade unionists alone. For the party it is an important alert signal: that is no way to develop inner-enterprise democracy, to raise the activity of workforces, and--what is especially significant--to step up comprehensive union activity.

The unionists themselves are frequently at fault: they appear solely in their first and traditional role of spokesmen and advocates of workers' rights. Some activists very narrowly conceive the motto, that greater rights imply greater duties. Let us therefore remind them that they are not concerned solely with the protection of working people's social and living standards.

In some enterprises one can already see where all that leads. There one can find areas of social and economic life left unattended--a "no-man's land" where nothing much interesting or new ever occurs. That is what happens, for instance, in the area of workers' education and culture, left without any, however moderate, support in form of union patronage. For the same reasons, there are shortcomings in the areas of professional advancement and in the innovators' movement; the search not only for technological innovation, but for the development of various forms of afterwork leisure, recreation, sports, etc., enjoys little encouragement. All that could impart work with more profound meaning, could bind people strongly together, could link them to the enterprise, is left in a "no-man's-land."

How not to lose such values? How to find them a place in the trade union activities? That is, in my view, the number one concern of party members.

Let us not deceive ourselves: It is not easy, and it will not be appreciated by all party committees, which above all expect greater unionists activity in the area of production. They, too, commit a mistake, striving at fulfillment of wage demands, most frequently raised by workforces. Only later do they recall housing, conditions and safety of work, health and social services, and leisure. No wonder, therefore, that a considerable part of union organizations, pressured by their membership, give priority to wage revindications, and are confirmed in their workplace "patriotism."

Unionists with a PZPR membership card have therefore a fruitful but difficult task to fulfill. Fruitful, because they are able to support union organizations in their positive aspirations, and to increase their penetrating force. Difficult, since they have to learn the art of persuasion, to explain party policies, to search for supporting arguments.

Such a style of cooperation, defined at the Ninth Congress and reaffirmed in the resolution of the 10th Plenum of the PZPR Central Committee, has not yet entered the everyday practice of party activists. Our comrades are frequently unable to raise objective insight, tact, and principled faithfulness in enforcing the proper duties and obligations of party-member unionists.

How are we supposed to rate those PZPR organizations which stay aloof from workers' unions? Since the party has taken an unambiguous stand in this issue, is that how the party discipline should look like? What happened to the party responsibility and ethos, when management clearly ignores union activists and reacts to its more energetic initiatives or efforts to fight against evil practices, by raising the spectre of ... extremism?

Let us also pose the question, What kind of example might such comrades set for their non-party colleagues, how can they lead them, if they themselves are not close enough to the shopfloor concerns and human anxieties?

There is nothing much better to a certain leniency, displayed towards those union activists who find it easier just to complain about bad management, and to wait what the party might be going to tell them to do.

The place and the role of the two workers' organizations, which above all represent interests of the same class, should define their mutual relationship. Together, jointly, hand in hand--that is what life suggests, what Marxism-Leninism teaches, and what the conference participants have also pointed out. But, unlike the previous period, without party ordering about and substituting for [unions], without union indolence.

That is the very first thing of which worker activists should be reminded again and again, also because life sets them ever higher and higher demands.

As far as trade unions are concerned, all that does not mean just broader powers, but also the co-manager's responsibility in the enterprises and throughout the nation, responsibility of those to whom workforces' demands and aspirations are addressed, those who are the animators of many useful social initiatives. For the party--the spokesman of stronger position and broader jurisdiction of the trade union movement--it means concern for the efficient functioning of this important link in the socialist democracy.

#### Labor Code Amendment Spurs Debate

Warsaw RZECZPOSPOLITA in Polish 20 Nov 85 p 4

[Article by (Or.): "Labor Code Amendment: Trade Union Jurisdiction: Controversy Concerning Recommendation"]

[Text] The Commission for Labor Code Amendment met for the fourth time at its plenary session on 19 November. During the debate, chaired by its deputy chairman, Prof Zbigniew Salwa, suggestions were discussed for amending the labor code regulations concerning the tasks and the jurisdiction of trade unions. The

deliberations dealt, above all, with the question, how union rights, recently redefined in the Trade Union Law, should be inscribed in the labor code in a way which would prevent conflict between the two legislative acts. Those are the most important issues, because they will determine the proper formulation of essential union functions--protective, educational, and participatory ones--that is to say, the union co-participation in some decision making.

In the discussion, major attention was paid to the role of higher-level union bodies in solving specific employees' problems. According to the present regulations, they were supposed to agree, for instance, to the property of terminating employment contracts. It would be hard to imagine that such a practice could be maintained. The majority of the commission members shared this view. But the problem was not definitely resolved, and an appropriate team was instructed to prepare two versions of the formulation.

The commission also dealt with the employees' recommendations, or--to be more precise--[with the question] who should take part in their final formulation. Until now, if an employee disagreed with a recommendation written by his superior, he had the right to apply to two higher-level bodies--his own and the union's--to confirm the formulation suggested by himself. That has now diametrically changed. The [industrial] associations no longer exist; the trade union structure is also different. Three suggestions were therefore proposed. The first one assumes that the manager will formulate the recommendation jointly with the union organization in the enterprise. The second one suggests that the union would be consulted about a recommendation prepared by the manager, but the union's opinion will be a non-binding one, and the final shape of the recommendation--in case of disagreement--would be settled in courts. Finally, according to a third version, the manager would decide about the final contents of his recommendation, since after all--as it has been pointed out--it deals only with how one's work is rated. The union would be allowed to present its own opinion, but in a non-binding manner.

According to another suggestion, the general practice of giving recommendations to employees should be entirely abandoned in the future.

The commission will resume deliberations on this question, and on others, at its next session in December.

#### Miner Unions Inaugural Council Session

Warsaw RZECZPOSPOLITA in Polish 20 Nov 85 p 2

[Article by (mt): "Inaugural Session of the Council of the Federation of Miner Trade Unions"]

[Text] On Tuesday, 19 November, the inaugural meeting of the Council of the Federation of Miner Trade Unions--a new, inter-enterprise union structure, established through a merger of three until now autonomous largest miner federations--was held in Katowice. The new federation unites 270 trade union organizations, with total membership of 360,000 employees in hard-coal mines,

copper mines, nonferrous metal mines, chemical raw-materials mining, as well as in mining-machinery industry and in the so-called mining hinterland.

Even though the three remaining inter-enterprise structures active in the mining industry--i.e., unionists from soft-coal mines, oil and gas industry, and rock breakers--have not yet joined the new federation, the merger constitutes a major stage in the integration of the revived miner trade union movement.

During the debate, in which Alfred Miodowicz, the OPZZ chairman, participated, the makeup of the council's presidium was approved, and its chairman elected. In a vote, this function was entrusted to Rajmund Moric, chairman of the former Trade Union Federation of hard-coal mines, mining construction enterprises, and PBSZ.

"Most of us realized from the very beginning that sooner or later the striving for unity had to prevail," said Rajmund Moric. The trade union movement, after all, has always aimed at overcoming divisions and at unification, regarding unity as its strength.

"Today representatives of former federations, and therefore the various union organizations and their membership, have confirmed that they abhor all kinds of particularism and that they are guided by one principle--the unity and strength of the miner union movement. We shall need it very much, as we are faced with enormous tasks linked to the strengthening of the role and significance of our movement in the enterprises, nationwide, and on the international scene, to defend the professional status of miners and of our labor veterans. Among the most urgent questions which still await solution, there are problems of major importance to the mining industry, such as restoring wage systems, housing construction, working hours, and improving the lot of retired and pensioned miners."

#### Teachers Union Seminar

Warsaw TRYBUNA LUDU in Polish 21 Nov 85 p 5

[Text] The Polish Teachers Union, active for 40 years at the Warsaw University, held a seminar on "The role of trade unions in a socialist university."

12485/8309  
CSO: 2600/154

POLITICS

POLAND

NEW BOOK PROFILES LEADING POLITICAL PERSONALITIES

Warsaw POLITYKA in Polish 21 Sep 85 pp 1, 7-10

[Review by Zbyslaw Rykowski and Wieslaw Wladyka of book "Kto jest kim w Polsce?" [Who's Who in Poland] by Andrzej Kepinski in collaboration with Zbigniew Kilar, Czytelnik Press, 1985]

[Excerpts] Who rules us?

Who are the people in power, how did they rise to eminence and how do they live and think?

People have always been interested in affairs at the top, always intrigued by the secrets of the political luminaries, but unable to learn much from credible sources. The political culture of the ruling camp did not accomodate publicity about politicians other than the leader, their personalities and, the more so, their private lives .

And yet in our country, too, politicians have differed greatly -- in knowledge, ability, temperament and inclinations. This can be ascertained by subsequently reading memoirs and reminiscences . As a rule, however, they have been and are presented in the likeness of a single model of activist mandatory during successive stages in history -- the member of a collective phalanx. Collective thought and organization was dominant, and they merely were the executors of collective will.... As shaped by leftist tradition, the model activist was a humble man subordinating his personality to discipline and deliberately minimizing his "I" in public contacts. There is thus nothing surprising in that people in power were perceived as uniform totalities of selves. Now and then only an anecdote was circulated about a particular person, and sometimes a rumor was repeated, usually a malicious and untrue rumor.

There were no individuals, there were only institutions. And only when the period of upheaval arose did the institutions come alive, the persons forming them express their thoughts distinctively, and unorthodox political personalities appear . It turned out that politics is made by individuals, that particular individuals commit mistakes, and also that particular other

individuals reflect the society's aspirations. It turned out that individuals are responsible for politics.

There is no democracy without political responsibility. There is no political responsibility when politics is depersonalized, anonymous, nonpublic, when it is not linked to and identified with particular individuals. The demand for introducing and adhering to the principle of political responsibility was one of the loudest slogans proclaimed in August [1980, Solidarity]. The post-August months were a most difficult test for politicians. At the time it was not enough to be right; one's right reasoning had to be confronted with the reasoning of others, it was necessary to convince others about it in the heated atmosphere of rallies, to speak extemporaneously, to answer questions for which one was not prepared, to have character. The years 1980-1981 initiated a new style of exercise of politics, a new style of public existence of the individuals in power. They are no longer anonymous. They have their own faces, well-known from television programs, their own language, their own style of speaking and arguing, and their own ridiculous traits. They are liked or disliked, and they gain approbation or irritate, as individuals. Nowadays John Q. Public can form his own views on politics and is enabled to judge those who personify it.

The book "Who's Who in Poland," recently published by Czytelnik Press, may be regarded as a symptom of the evolution of a new political culture in Poland misleading, since it suggests yet another collection of brief biographies. In reality, this book, prepared by Andrzej Kepinski in collaboration with Zbigniew Kilar, contains 24 extensive interviews with leading personalities in Polish political life. These interviews are, let us say it at once, not banal. The young Jelenia Gora journalists do not content themselves with listening to the views of the interviewees, already known as they are anyway. They ask them about their roads in life and their personal attitudes toward past events, toward events agitating public opinion nowadays and toward their own careers and political roles. Lastly, they ask them about their successes and failures, their likes and dislikes and their private lives.

Kepinski and Kilar talked: with the Chairman of the Council of State Henryk Jablonski, the Chairman of the National Council of the PRON [Patriotic Movement for Poland's Rebirth] Prof Jan Dobraczynski, members of the PZPR leadership (Kazimierz Barcikowski, Jozef Czyrek, Zofia Grzyb, Hieronim Kubiak, Marian Orzechowski, Albin Siwak), the current Chairman of the NK ZSL [Supreme Committee of the United Peasant Party] Deputy Prime Minister Roman Malinowski and his predecessor Speaker of the Sejm Stanislaw Gucwa, the current Chairman of the CK SD [Central Committee of the Democratic Party] Tadeusz Witold Mlynczak and his predecessor Deputy Prime Minister Edward Kowalczyk, the PAX [Catholic Association] Chairman Zenon Komender, and members of the Government (Wladyslaw Baka, Stanislaw Ciosek, Manfred Gorywoda, Zdzislaw Krasinski, Zbigniew Messner, Janusz Obodowski, Czeslaw Piotrowski, Mieczyslaw Franciszek Rakowski, Zbigniew Szalajda, Jerzy Urban and Kazimierz Zygulski).

As a result, we have not just personal descriptions of the abovementioned politicians but also a kind of group photograph of the political leadership group.

This group consists of individuals with variegated personalities and backgrounds . The oldest of them (Jablonski and Dobraczynski) are now 76 and 75 of age, that is, they had been mature individuals already before the war. Adulthood was reached in 1939 by Gucwa, Komender, Kowalczyk and Zygulski. The others reached it after 1945. The youngest ones (Ciosek, 46 years old, and Gorywoda, 43) were raised and formed in People's Poland. Thus, by the nature of things, life experiences and direct experience of history must differ among members in this group.

An overwhelming majority of the book's protagonists had been too young before the war to understand the dilemmas of those times and resolve them consciously. They have memories, however, of impressions, images, situations.

The war was to the older ones a time of political, moral and ideological testing, while to the younger ones it was a period of accelerated maturation. To all, it was a traumatic experience.

The war was also a time of basic political choices. Some made their choice deliberately, while history decided for others .

In late 1942 and early 1943 Dobraczynski wrote the article, "Russia, Our Most Important Neighbor," in which he demanded that the prewar policy toward the Soviet Union be reconsidered. Jablonski in his articles pointed to Soviet experience in solving fundamental social problems, supported Sikorski's line and regarded the rupture of Polish-Soviet relations as a "major mistake." Kazimierz Zygulski was arrested by Soviet authorities in August 1944 in Lwow and, together with the entire group of delegates from the London Polish Government-in-Exile, tried and sentenced to 15 years of imprisonment; he returned to Poland only in 1955, and in 1976 he was rehabilitated by the USSR Supreme Court. Following Operation Storm [Akcja Burza -- In November 1943, the Commander-in-Chief of the Polish Home Army ordered launching the so-called "Burza" plan, drafted in cooperation with the emigre Polish government in London. Its political aim was to attack the retreating German troops and set up a noncommunist government in the liberated Polish territories]. Zenon Komender was interned [by the Soviets] and returned to this country at the end of 1945. Hieronim Kubiak and Jozef Czyrek recall the offensive of the Soviet Army as liberation from the Occupation. Czyrek reminisces: "The liberation was brought by detachments of the Red Army, welcomed with unusual cordiality by the population. In our house was billeted a captain, a teacher of mathematics by profession, who helped me with my homework, a homework that also happened to include first lessons in the Russian language. At the same time, a distant relative who had before 1939 lived in Eastern Poland [annexed by the USSR] was dwelling in my family's home. He brought with him from his native region an antipathy toward the Soviets -- an antipathy whose correctness from his standpoint I'll not go into. After Soviet troops arrived, he told me that he would have preferred not to live to that day, or something of the kind. This kind of reasoning on the part of a representative of a nation that had been condemned to extermination by the Hitlerite occupier shocked me so much that, notwithstanding the venerable age of my relative, I called him a fool and other epithets and included him among unjust men. That was probably the most pro-Soviet ever speech I made in my life. It was prompted not by ideological

or political motives but by a simple and natural reflex on the part of a young boy, dictated by his feeling for justice. And so, certain views or attitudes are formed not only by textbooks but also by particular life situations." In February 1945 Mieczyslaw Rakowski volunteered for the army. "My chief motive was the desire to avenge myself on the Germans, and thus this was not a political but, so to speak, a patriotic decision. The fact that the army came from the East was of no importance. Had it come from the West, I would also have joined it. I say this because I'm shocked when men of my age, who at that time were young, declare that in those times they had made a conscious choice. I listen to such confessions with a tongue in cheek. I don't claim that there had not been any individuals who made a choice, but I don't believe that this was the rule."

The ZMP [Union of Polish Youth] generation clearly dominates the leadership group represented in the book. In the lives of the men nowadays in their 50's and 60's the period of their activity within the ZMP and its predecessor organizations left a permanent imprint. Kazimierz Barcikowski says: "It is simply that what we call nowadays the advancement of youth took place all around us, and the youth associations were the organizers of that advancement. The young people who at that time migrated from the countryside had to be given a helping hand. The ZWM [Union of Young Fighters] and the ZMW [Rural Youth Union], and later the ZMP played that role. Assistance from youth organizations was often the sole support received by young people leaving the countryside for the new urban environment, so distant from the traditional." This generation absorbed Marxism, which freed it of uncertainty and brought order into history. To Marian Orzechowski and Jerzy Urban the most important things they read were the books by Adam Schaff, "Pogadanki ekonomiczne" [Chats About Economics] and "Wstep do teorii marksizmu" [An Introduction to Marxist Theory]. Urban joined the ZMP in the fall of 1948. "At the time the ZMP was greatly different from the ZMP of 1955. It was still dominated by ZWM tendencies and, at the time, a minority rather than a majority joined it. We felt like destroyers of a stagnant world. The ZMP was the rebellion of the generation, as well as a rebellion against outworn customs. A youth subculture arose within the ZMP. I sang mass songs and danced the "Labad." Marxism was fascinating. Within the ZMP one could also find his own 'group of buddies.' Of course, I'm not speaking of the motives behind the ideological choice made by young workers, because they certainly were different. The intelligentsia youth to which I belonged at the time read books like the ones by Schaff and suddenly experienced a sudden illumination, the shock of recognition, or an epiphany. This caused conflicts with their families and the questioning of all shopworn customs and mores. We were the vanguard of a new lifestyle, including the style of drinking and sex even. All this was contrary to the stagnant old world. But then the fundamental political constructs also were contrary to the stagnant old world with its traditional values. That was in the nature of a youthful romantic adventure." The old world formed by its traditional value was at the time defended by Zenon Komender, a student at the Wroclaw Polytechnic, who headed the illegal "Endecja" [National Democrats, a conservative political movement] youth organization, "Youth of Greater Poland." Prior to elections to the Legislative Sejm he was arrested, and he spent 6 years in prison. Today he is convinced that "they are right who always bear in mind that politics consists in planning and carrying out feasible goals."

The book's readers are bound to be struck by the warm attitude of its protagonists toward the atmosphere of the family home, which the protagonists consider to be their most formative experience.

Home was also the place of initiation into politics. The families of Barcikowski, Ciosek, Czyrek and Gucwa were linked to the populist movement; those of Jablonski, Kowalczyk, Obodowski, Orzechowski and Siwak, to the socialist movement; those of Urban and Zygulski, to the circles of liberal-leftist intelligentsia; and those of Dobraczynski and Komender, to the nationalist-Catholic movement. They all admit that the ideological atmosphere at home was a major factor shaping their world outlook and road in life. Albin Siwak says: "I believe that if my father were still living, he would feel highly dubious as to whether we are pursuing an effective class policy. I never depart from the principles instilled in me by my father."

However, the lives of a majority of present-day politicians were above all influenced by social transformations. Their personal advancement was closely linked to the advancement of the communities from which they derived. Of the 24 persons interviewed in the book eight are of worker origin, seven come from peasant families, five from the intelligentsia and four from, so to say, the petty bourgeoisie. As of the present, eight have the academic rank of professor, six have doctoral degrees, six others are graduates of higher educational institutions, two have a record of incomplete higher education, and two were vocationally trained.

#### They Reached Their Current Eminence in Various Ways

Some climbed successive rungs on the career ladder of the professional politician (e.g., Barcikowski, Ciosek, Komender, Malinowski, Mlynczak, Rakowski), while others took the path of government officials and economic managers (Obodowski, Szalajda). Others still switched to politics from civil service (Czyrek, Gucwa). Still others are nonpolitical experts appointed to certain offices (Krasinski, Urban, Zygulski). A phenomenon characteristic of recent years is the career of politically committed university professors (Baka, Kubiak, Messner, Orzechowski). The representatives of blue-collar communities in this leadership group are Grzyb and Siwak.

They speak with reserve about their careers. They stress that they are not careerists, that it somehow happened of itself. Barcikowski: "Hmm, sometimes I wonder why is it exactly I who became [a PZPR Central Committee] secretary. I'm increasingly convinced that this is due to a lucky combination of circumstances." Czyrek: "...It was never my goal to pursue high office. Life itself somehow led me toward a chain of activities and caused me to exercise some rather than other functions." Ciosek: "...I've never planned my career -- the juncture of events rather was decisive. I never struggled for high office, and I made various choices. I didn't, for example, establish cliques or claques supporting my advancement. In connection with the above, I've no plans for the next stage in my life either, although I do consider myself a politician." Ciosek considers himself a politician but Krasinski does not: "I don't regard myself as a political animal.... I agree that price controls are part of an extremely intricate web of measures influencing the public mood, but this in itself still isn't authentic politics regulating social behavior

as construed in the sociological sense." Krasinski views his role as that of an expert. Obodowski sees himself as playing a dual role: "I'm a deputy chairman of the Council of Ministers, but it would be difficult to say that I'm merely in the civil service. In many countries this office could be termed that of a 'statesman.' This sounds dignified and, to me, somewhat pathetic. Formally speaking, I'm in the government civil service, but in taking decisions that are par excellence political I'm also a politician. I must be continually aware of this." Orzechowski, a professor of history, declares that one is a historian but happens to be a politician for a while: "Politics is joined to, as a rule, a social function, although in our country too there exists a group of professional politicians. But in my case I'm a politician exercising an elected office. My term of office is determined by the party statute, elections and voters." Mlynzszak claims that the time of amateurs in politics is coming to an end: "Perhaps a few amateur politicians still survive, but their time is slowly beginning to be over. The politician's practice of politics, his honest and conscientious implementation of his obligations to the people, is surely not merely a question of charisma or talent. It also is a question of constantly updating one's knowledge, growing in experience and simply working hard on behalf of others." Mlynzszak wants to see politics as a profession, while Grzyb and Siwak are concerned about its representativeness. Zofia Grzyb considers herself to be "delegated" to the top with the object of watching over the implementation of the resolutions of the 9th Congress. She does not want to be a professional politician; rather, she desires to represent the opinions of workers. "My role and daily duties do not consist in engaging in academic disputations with scholars."

#### How is the Summit Reached?

The leading members of the PZPR, the ZSL and the SD were elected. Those holding government offices were offered them by the prime minister. To many, these offers were surprising. Wladyslaw Baka admits that to this day he does not know what motives prompted the General. Likewise, Stanislaw Ciosek also has not explored the reasons for his nomination. A telephone call from the Office of the Council of Ministers surprised Zdzislaw Krasinski. Jerzy Urban, who felt uncomfortable in 1981 in his post as an editor of POLITYKA, was offered the post of the government press spokesman by his editor-in-chief Deputy Prime Minister Mieczyslaw Rakowski. Toward the end of June 1981 Gen Czeslaw Piotrowski was summoned to the office of the prime minister and offered the post of minister of mining and power industry. "At first I treated this as a joke, for I lacked the necessary experience and the more so the conviction that I could cope with the duties associated with such a responsible high office. I asked Gen Jaruzelski whether this was an order which I, as a military man, had to obey. The answer was: 'No, this is a request.' In such a situation I couldn't refuse." When the PRON was being established, Gen Jaruzelski asked Jan Dobraczynski to visit him and posed to him the question of whether he wanted to help. "When I said, 'I trust and desire to trust you, General,' he proposed that I head the PRON. When I began to protest that I'm an old man and never was a politician, the General said: 'Sir, if you, a man who is aware of our difficult situation and knows that we are standing on the brink of a catastrophe, will not counteract it, who else will? You, sir, are known for leaping into the saddle like a cavalryman ...' This decided me."

People come and go. The book also mentions departures from the political arena. Krasinski is of the opinion that high offices should be held for 3 or at most 5 years. "Afterward, one falls into a rut, becomes complacent, and then the roof falls in."

The ruling group feels the burden of the responsibility that it took on its shoulders on 13 December 1981 [when martial law was declared] . Every interviewee wanted to justify the necessity of introducing martial law. And every interviewee argued convincingly that the worst is already behind us, that the country can be rescued from the crisis and that its return, the repetition of mistakes repeated so often, can be averted. The nature of these mistakes has been clarified. Hieronim Kubiak declared that no one can any longer argue that he did not know. Thus it is known that there can be no turning back from the reforms. But it is also known that the application of these reforms is a process that is neither simple nor easy. Reforms have to be reconciled with emergency measures and interventions. And the principal problem is how to reconcile what is necessary with what is possible. Kubiak: "If programs are revised in the course of their implementation, one must always ask at what moment do the revisions nullify the programs themselves so that only their appellations survive. We must particularly bear this in mind. It is clear that revisions are needed, because they are dictated by, among other things, collisions between postulated goals and accomplished goals. On the other hand, if the revisions become a bypath leading to the restoration of the past, the intentions of those performing the revisions have to be closely scrutinized."

The principal feature of the thinking of the ruling group presented in the book is realism .

This realism ensues from criticism of the state of social awareness. Kowalczyk traces the wellsprings of what he sees as low morale to the relics of the petty-nobility mentality of Poles, to their national defects. Obodowski says: "It is hardly surprising that people, particularly young people, want to live better. But the negative thing about it is that people often desire to attain improvements in their material welfare without exerting greater personal effort. It is simply that someone else is supposed to accomplish this for them. It is an evil that we implanted consumerist attitudes so deeply in social awareness." Messner believes that we must break through the psychological barrier of attitude toward work, shape a production-oriented awareness. Krasinski views us as an emotional nation; he would like to imbue Poles with the industriousness, patience and self-discipline of Japanese. Piotrowski is pained by the devaluation of such concepts as honor and the fatherland, by the decline in discipline, the degradation of personal dignity, the loss of mutual respect, the erosion of ambition to lead in work and serve others. "Concepts such as truthful speaking, sincerity, honesty or reliance on verbal agreements such as 'word of honor' are disappearing from daily life." The transformation of social awareness is regarded by the politicians as a fundamental task of politics and a requirement for overcoming the crisis. They acknowledge that the decisions they take may be unpopular. They expect that a new social practice will alter old attitudes. Malinowski says that politics is deeds, not words. "Even the most eloquent words in politics are of

no major importance unless they are followed by deeds, by specific effects." Messner does not believe in any substantial progress unless it is supported by arduous toil and collective effort. Ciosek is convinced that one day our present troubles will seem like a bad dream. "On one condition, however, namely, that we shall not again dream of some great leap forward, that we'll prove capable of a patient and gradual overcoming of difficulties, one after another rather than all at once." According to Komender, patriotism "is above all an imperative for action; it also means persistence and consistency in formulating and implementing specific, realistic and feasible programs, rather than declarations that often ignore realities and procedural practice." Janusz Obodowski says: "There are no miracles in economics. Nothing is gotten gratis. Whoever tries to disregard these rules, loses." Piotrowski also warns against faith in miracles: "Miracles don't and will not exist -- this precisely has to be believed. So then, everything is up to us and ahead of us." Such precisely is the basic premise of the political philosophy followed by the ruling group.

#### When Participating in the Exercise of Power the Dilemma Between Loyalty and Independence is Often Difficult to Resolve

In Baka's opinion opportunism is the greatest peril to the politician as a person. He means not the opportunism prompted by fear or selfish interest but the one justifiable by "the good of the cause" or too by the desire to "minimize evil." Ciosek somehow reconciles independence with loyalty.... There are moments at which a politician must take a position on an issue. Roman Malinowski once declared that if the so-called "peasant entry" amendment [the legalization in perpetuity of private farm ownership] is not added to the Constitution, he would retire from politics. He says: "Consistency and determination accompany or should accompany difficult but necessary situations." He believes powerlessness to be the acme of misery; he fears most the mistakes due to ignorance and arrogance.

The politicians talk about their successes, but they also talk about their failures. The latter are of twofold kind; they consist either in the loss of office or in policy defeat. Stanislaw Guca resigned in 1980 from the post of chairman of the NK ZSL [Supreme Committee of the United Peasant Party]: "I had been conscious that the various notions and ideas then appearing would lead to the breakdown of the entire populist movement in this country. The presidium of the NK ZSL agreed with my views. However, the resolution of the Tarnow Province ZSL Committee to deprive me of the chairmanship of the ZSL was a hard 'blow' to me...." Tadeusz Witold Mlynczak failed to be re-elected at the 12th Congress of the SD [Democratic Party]. "I simply lacked four votes to win. The times were terribly difficult and, as a journalist had written, 'democracy ran amok among the Democrats....'" Kazimierz Barcikowski resigned in 1977 from the post of minister of agriculture in order to protest against the agricultural policies of the time. But it is not this defeat that hurts him most. He claims that in a sense he suffered a defeat once the martial law was introduced. "It's simply that in 1980 I had judged too optimistically the party's ability to guide the process of changes. It turned out that the party was more alienated [from the people] than I had perceived, and by the same token its ability to guide social processes was limited." To Hieronim Kubiak it was 'a defeat, even a disaster,' because in the years 1981-1982 he failed to convince

of his rationale those he had wanted to convince. "I failed to convey to the artistic community a critical grasp of the paramount goals that could have led to concerted action. Everyone had to pay for it needlessly, I too." Mieczyslaw Rakowski believes that all those who had in the fall of 1980 bestowed their trust on the leaders of Solidarity, all those who had believed that it would be a genuine trade-union movement, turned out to be losers.

However, he does not abandon the idea of partnership. "I still believe that relations of partnership, not only between the organs of the state and, e.g., the trade unions, but also among social classes and groups, must provide the basis for the coexistence of Poles and the point of departure for every action by the party and the government." In the book, comments by members of the PZPR, the ZSL and the SD as well as by nonparty members adjoin each other. They also mention the relations between the party and the allied political parties [ZSL, SD] as well as between the state and the Church. Gucwa admits that in the 1970's the cooperation between the PZPR and the allied political parties was weak .

When reminiscing about their childhood the currently prominent members of the PZPR speak of their Catholic upbringing. Ciosek was an altar-boy. Siwak had his Confirmation and knows by rote quotations from the Holy Scriptures. Kubiak, while an instructor at the Krakow party committee, moonlighted by teaching Russian at the well-known school of the Piarist fathers.... Siwak and Kubiak declare that they personally are not enemies of God. Kubiak ponders how to answer the question of why and under what conditions men need religious consolation as a compensation for their personal or social downfall. In the nature of things, a major topic of the interviews had to be the problems of the relations between the state and the Church, and between believers and nonbelievers. Barcikowski: "I think that the Church would be the first to protest if we were to claim that it has been maintaining amicable relations with us, but I lean toward the appraisal that these relations withstood the test of the crisis at a time when national interest, the question of the existence of statehood, was at stake. At those moments we found sufficient common ground and succeeded in avoiding actions that could have been controlled neither by the state nor by the Church. In accord with the principles of separation between state and Church there should not have been disputes about, e.g., the crosses [this refers to the famous affair of crosses in the classrooms at a provincial school]." Dobraczynski: "There are issues on which a consensus exists regarding Polish statehood or importance to the nation, and concerning such issues a way must be found to take joint action. Of course, such an attitude requires sacrifices from both parties. Priorities have to be decided upon.... As a Catholic I would like the cross to hang everywhere. But I realize that we are a secular state, though one in which an overwhelming majority of the population are believers, and I understand that the cross can't hang everywhere, particularly considering that often those who clamor so loudly for the cross do not prove by personal example that they are followers of Christ...." Orzechowski: "Socialism in Poland is built with the hands of Catholics. It was not the elves that reconstructed the country, built factories, etc. Religion need not be an obstacle to social, socialist commitment!" Hieronim Kubiak says: "Practicing partnership is not easy. Socialism can be built in the absence of many things, but not in the absence of support by a majority of working people. The very nature of socialism-

building implies the need to win the acceptance of the basic social forces for this idea and -- what is still more difficult -- for the manner in which it is implemented. One possible form is to rally together all the forces that say, 'socialism -- YES, distortions -- NO.' Even if for some of these forces saying YES to socialism is quite difficult or freighted with additional doubts. Hence, in practice, it is an unusually difficult but also highly important thing to create conditions under which people of differing outlooks, from different walks of life, who acknowledge the Constitutional principles of the stability of the foundations of the Polish mansion, could say that it is their own mansion, that they feel at home in it and that they know what is needed to bring it into order so that life in it would be happier."

The book's reader gains the right of access to the private life of politicians . From the book he learns that generally they identify happiness with family life. They do not have much time for it. For the work day of a politician does not end at 5. When Malinowski succeeds in snatching some leisure time from politics, he sits down to play chess with his sons Marcin and Maciej. (Martin Luther and Maciej Rataj [1884-1940, a prominent peasant-party politician and speaker of the Sejm] are his favorite heroes). Gorywoda fishes or reads. Recently he read a book about secret Luftwaffe units. Urban has no luck with women but likes to lie abed. Malinowski resolved to stop smoking this year. Kubiak is a pipesmoker. "As my wife says, the best part of myself was smoked in the pipe." Siwak is proud of his daughter, a biology graduate who now teaches at school. Kowalczyk remains impressed by Bobrzynski [Michal Bobrzynski, 1849-1935, historian, professor at Jagiellon University], Herzen and Kucharzewski [probably Feliks Kucharzewski, 1849-1935, engineer and historian of technology]. Barcikowski is a great fan of Reykowski [Ewaryst Reykowski, 19th-century emigre Polish politician in Paris]. Gorywoda used to play soccer. Mlynczak engaged in bicycle racing. Malinowski was a boxing referee. What do they get out of politics? Stress and heart attacks.... Kubiak states: "In our circumstances leading a politician's life is extremely difficult and, from the material standpoint, relatively ineffective. I know of many other ways of earning a living that produce greater results with a smaller investment of personal effort. In the period when I became a member of the authorities politics -- fortunately -- no longer was a financially profitable vocation. Nowadays one has to live not from politics but for politics." What is ahead for them? Baka says: "Everything indicates that life will confront one with ever more difficult decisions." But what is to be done.... such is the nature of this profession!

\*

Andrzej Kepinski (32 years old), journalist, sociologist, graduate of the Adam Mickiewicz University in Poznan, and Zbigniew Kilar (36 years old), journalist, sociologist, graduate of the Higher School of Social Sciences the PZPR Central Committee.

An Interview with Andrzej Kepinski by (WiP)

[Question] How was this book conceived?

[Answer] First there was the idea itself of the interviews, or rather the

conviction that such a book is needed, that a demand exists for this kind of dialogue. We wanted to try it, but we didn't know how, and what formula to follow. It took us even longer to gain access to our future interviewees. We had to make dozens of phone calls, cross one threshold after another, persuade secretaries and advisors. Altogether, that was the least interesting part. Later, things got easier.

[Question] That was probably the first experience of this kind for you both.

[Answer] Yes. We set up a two-person team of which I became the leader. I'm a journalist, and I commenced my career in Jelenia Gora. Later, I was deputy editor-in-chief of WIADOMOSCI ELBLASKIE. The for a long time I warmed no armchair until I joined WPROST, the Poznan weekly. I took a one-year unpaid sabbatical and we started work. My associate is also a sociologist by education, and he is the PAP correspondent in Jelenia Gora. Previously he worked at the Jelenia Gora Province PZPR Committee. It was he who set up our files, collected clippings and prepared the documentation for each interview.

[Question] I understand that you received a government stipend for writing this book.

[Answer] This is mere rumor. To be sure, at one time we applied to the Government Press Office with a request for help in our project.

[Question] But why precisely these party and government personages and no other were interviewed.

[Answer] We contacted every representative of the Politburo and the government. Some simply couldn't find the time for us. Right now we're working on volume two and hoping to publish in it other interviews.

[Question] Often the practice as regards interviews in these domains -- this being part of our political culture -- is such that the journalist submits written questions and the answers are prepared by a gaggle of officials who exert themselves in making them as officialese and as colorless as possible. What was your experience in this respect?

[Answer] In a few, only a few, cases we submitted in advance written questions, or rather, a scenario of the interview, of the topics, of our expectations. The problem was different. Namely, each time we realized how little we knew about our interviewees. A short biographical citation and a soupcon of gossip. Hence we regarded these interviews as our modest contribution to changing the political customs. We also attempted to prove thereby that such changes do occur.

[Question] And did you succeed?

[Answer] That's for our readers to judge. Once we gained access to anterooms and offices, we were surprised by the great cordiality and candor of our interviewees, as a rule. They didn't erect an artificial barrier, didn't try to talk down to us. We had the impression that they're ordinary normal human beings who merely happen to play important public roles nowadays. When

starting work on our book our goal was that it be read with interest by our friends and political opponents. After all, this is a political book -- not only at the time of its publication but also in the future. In other words, it mattered to us a great deal that this book wouldn't meet with the fate of ephemeral works.

1386

CSO: 2600/62

SCIENCE AND TECHNOLOGY

BULGARIA

SPECIFICATIONS OF 'ES 1055 M' COMPUTER

Sofia TEKHNICHESKO DELO in Bulgarian 28 Sep 85 p 5

[Advertisement: "This Is Our New Computer. Its Name Is ROBOTRON ES 1055 M"]

[Text] Its specialty is complex problems, particularly in resolving the voluminous multiple-shift problems which may arise at combines, enterprises, administrative establishments, transportation and communications, institutes and design bureaus. Its main advantages are the following:

Small dimensions and low energy consumption as a result of the use of highly integrated change-over circuits and modern power feed;

Use of different methods for remote control data processing and application of a computer drive in the complex computation system;

Maximal operative memory capacity: 4,096 bytes;

Carrying a load of 16 megabytes for a more efficient memory storage by using the virtual principle of memorization;

Operating in the expanded command module, using the operative principles based on the ESER 2, and in the basic command module, based on ESER 1.

The most interesting and effective new feature, however, is the SVM/ES operational system, based on virtual machines. Each one of these machines works as a separate instrument with its own power and controlled by its own operational system based on selective requirements.

Robotron Export - Import  
German Democratic Republic State Foreign Trade Enterprise.  
GDR - 1140 - Berlin  
Cosmonaut Allee 24

Visit us at the GDR Pavillion at the Plovdiv International Fair, 30 September-17 October 1985!

5003  
CSO: 2200/21

SCIENCE AND TECHNOLOGY

BULGARIA

'BALKANKAR' LINE OF PRODUCTS DESCRIBED

Sofia TEKHNICHESKO DELO in Bulgarian 28 Sep 85 p 6

[Article by Lyubomir Stoimenov: "Balkankar"]

[Text] All 365 days of the year, across varying geographic distances leading to 67 countries, Balkankar conducts a mutually profitable dialogue with consumers, specialists and trade and industrial partners, meeting as fully as possible the requirements of individual customers and specific markets, for both the market and practice simply reject ineffective and unviable solutions. The market and practice are the testing grounds for ideas and materialized solutions, which also test our own requirements concerning the technical and operational qualities of the machinery.

The increasing strictness of the requirements is manifested in the steady aspiration of the largest Bulgarian machine building organization to expand and enrich its production and export variety of transportation and lifting machines and equipment maintaining on an uncontestable level the latest generation of Balkankar electric cars and engine driven trucks over the last 4-5 years.

Balkankar, which has adopted the scale and technological criteria of scientific and technical progress as its reliable yardstick, is developing its traditional output, combined with a 22 percent annual updating.

Let us back words with examples. The most representative display of Balkankar products takes place at the Plovdiv International Technical Fair in the autumn. At the 41st such fair, the Balkankar Scientific-Production Trade Trust exhibited 158 items, 104 of which were labelled "New." This applied to the entire range of products: electric cars, engine driven trucks, motor vehicle equipment, technologies, machine units and assemblies. This was a true illustration of practical accomplishments, showing the prospects of the multiplication approach in resolving production intensification problems.

Optimal combination of centralized planning with specific initiatives guarantees Balkankar a steady influx of modern scientific solutions in production and systematic updating of its material and technical base. The "science-technology-production" complex it has developed combines the

possibilities of scientific knowledge with practical requirements. At Balkankar science is a direct production force.

This is suitably illustrated with the items exhibited by the trust at the autumn fair. Balkankar is displaying both traditional and familiar items and a number of novelties in its export program, which allow it to upgrade the quality of servicing production, the communal economy and construction. As always, the determining share is that of electric cars and engine driven trucks. The Plovdiv display includes the full range of four-bed electric cars and general-purpose lifts of the Druzhba series, both in terms of hauling capacity and lifting height. The very term "general-purpose" says a great deal in itself. The new developments in this series include additional qualities, such as greater hourly and shift capacity, greater durability, ergonomic developments and the important repair convenience. Equally new are the three-bed electric cars, which are different only in terms of size.

Another decisive novelty introduced by Balkankar is the modular principle applied in the production of four- and three-bed electric cars, which greatly increases the standardization of assemblies and machine units of both models. All that can be said about this experience, which has already gathered inertial velocity, is that it is excellent in comparison with the best.

A specific solution is provided for each transport problem. This was the decision made by Balkankar specialists, who have offered a variety of specialized electric car models to meet a variety of transportation situations. The models which will be displayed in Plovdiv can easily be adapted to the optimal system of organization of transport services within a large transport complex, with reduced car maneuvering and maximally reducing production and freight handling costs. Manually driven and platform electric cars, electric tractors and trailers, low-lifters, electric cars with longitudinal lifting or three-sided freight handling, electric cars for hauling luggage at airports and machines for the communal economy, such as small head loaders and electric cars for clearing water canals are part of the extensive Balkankar production program covering the many-faceted sphere of services in industrial and other processes.

Once again, among the motor driven trucks powered by a diesel engine the record setter is the Rekord family, fully represented here, with its latest equipment: modifications with new types hydrodynamic transmissions, new types of diesel engines and new designs of hydrostatic transmissions. Whereas it was being asked in the past to give Rekord one more chance, today its chances are much greater. The possibilities of Bulgarian engine driven trucks are displayed with the Progres model trucks with a broad range of lifting and freight capacity models.

Whereas these models require hard and smooth paving of the work areas, the all-terrain motor driven trucks take over where the roadbed ends. These trucks are wonderful assistants in construction, forestry and agriculture with their great variety of quickly replaceable attachments. Such attachments include front and back hoes, concrete mixers, dumping drum, clamps, a bulldozer rake, a hydrolic ram, screw cutter, excavator bucket, grabber-loader and the well-familiar attachments for handling various types of bulk or

palletized loads. All-terrain engine driven trucks come in two series: with a hinged or fixed bed and two motor-powered and controlled axles. These are engine driven trucks equipped with motor vehicle machine units.

Particularly worth mentioning is the area of exhibits displaying the practical application of the technological criteria of technical progress, such as the application of basic technology, moving through a variety of technological systems towards technological specialization. Such exhibits include a robot car with a remote control panel, a robotized cart, a robotized technological module, a series of stands for input control data, development and display of the functional suitability of hydraulic products, a technical set for calibration and marking and a number of machine units and components used in ship and motor vehicle manufacturing, such as controlled lifting shafts, electric motors, electrical equipment, and interchangeable work attachments. This is, actually, the area of the exhibition which includes the largest number of "New" labels, for even traditional machine units exhibited here have been manufactured with the help of advanced industrial technologies.

The automotive vehicle equipment produced by Balkankar is a true example of international division of labor, cooperation and mutual assistance. For the time being the needs of the national transportation complex are met with motor vehicles produced in cooperation with the Soviet Union, Czechoslovakia, Romania and Hungary. Fruitful cooperation has been developed also with leading companies in the developed industrialized nonsocialist countries. At the same time, Balkankar is the monopoly importer of automotive equipment. This covers a range of passenger cars for the communal economy and trade and various superstructures for light-duty motor vehicles, such as dumping systems, trailers, city cars with trailers, heavy-duty mainline trucks, single and jointed urban and interurban buses and hitched equipment, such as trailers, semi-trailers, container and panel trucks, containers and tanks. All of these items meet domestic and import needs.

The extensive production program is also made possible by extensive combination facilities. One of Balkankar's essential advantages is its well developed functional infrastructure aimed at meeting intensive production requirements. Thus, 80 percent of these items are manufactured in Balkankar's plants and the remaining 20 percent in other Bulgarian enterprises. This makes car manufacturing independent of the fluctuations on the international market. A limited set of items or additional attachments are imported for custom-made models meeting the special requirements of a specific market or customer. The Plovdiv exhibit includes part of the long list of assemblies and machine units, such as new modifications of diesel engines, traction batteries and starters in new plastic containers. The exhibits also include power blocks and a broad range of axles--coupled, support, and front and rear for motor vehicles and electric cars, hydrodynamic transmission gear, filters and rims.

The distance covered by Balkankar in the 1980s has been marked by the confidence of the customers in 67 countries, reputation on foreign car markets and a strategy of using the latest accomplishments of scientific and technical progress.

What about guarantees for the future? Work is being done and concepts about cars projected to the year 2000 are being researched.

The Balkankar specialists constantly strive to achieve the maximal improvement of assemblies and machine units in order to attain maximal reliability, peak power and greatly upgraded efficiency. Conceptional changes will be included in the development and application of basic units, with the help of essentially new solutions to the problem of energy sources, power storage principles and means of transformation of energy into motor power.

That is why one can confidently say that our familiar Balkan is perpetually advancing toward new developments.

5003

CSO: 2200/21

SCIENCE AND TECHNOLOGY

BULGARIA

'BOLSHEVIK' PLANT ADVERTIZES ITS PRODUCTS

Sofia TEKHNICHESKO DELO in Bulgarian 28 Sep 85 p 16

[Advertisement: "Bolshevik Instruments Plant, Gabrovo"]

[Text] The Bolshevik Plant produces:

Cog-cutting tools: hobs for rough and finishing machining, hobs for evolvent castellated shafts, hobs for chain sprockets, disk shavers and flange gear milling machines;

Thread cutting tools: manual screw taps and machines for metric threading with open-end and close-end hole, screw taps for H and W-type metric threading with screw-type grooves, chipless screw taps, inch-threading screw taps, screw taps for nuts and for special electric fixtures threading. Manual and automatic round dies for metric threading, dies for inch threading and metric threading rollers;

Cylinder and end-cylinder milling machines made of fast-cutting steel, II, H, W, P and T-types, semispherical convex and concave, for cotter milling, angular, and for sectional setting;

Hole-machining tools: centering bits with a 60-degree angle, A, B and P types, with a cylindrical tail, made entirely of carbide, bits with replaceable carbide laminas, boring bits, boring bars with replaceable carbide blades for preliminary and final machining of open-end and close-end holes, broaching and boring tools for round, straight-slotting, curve-slotting square and special holes;

Metal-cutting milling tools with replaceable carbide blades -- face and face-circular high-efficiency chuck and tail, with a 7:24 metric bevel, with round replaceable three-sided and two-sided disk plates;

Lathe cutters with replaceable carbide laminas, with facilities for all types of machining operations on universal and numerical control lathes and aluminum machining cutters, cutters for machining inner and outer grooves and stop rings;

Sets for various types of tool clamps for the following: numerical programmed machines, such as MS-032, MS-025, TsM-040, TsM-080, RV-501-24 and RV 001;

Carbide gills -- cutting gills of all shapes with positive and negative cutting edge, single and double coating, filler gills and chip breakers;

Measuring tools: double callipers with depth gauges ranging from 0 to 150 mm with 0.1 and 0.05 readings, with millimeter and inch scales, made of stainless steel;

New products: tools made of speed-cutting steel with wear-resistant coating made of titanium nitrate, hobs, cog-drilling disks, shaft milling machines and metric threading taps.

5003

CSO: 2200/21

SCIENCE AND TECHNOLOGY

CZECHOSLOVAKIA

IMPORTANCE OF BIOTECHNOLOGY EMPHASIZED

Prague RUDE PRAVO in Czech 28 Dec 85 p 1

[Article: "The Biotechnological Program"]

[Text] The development of biotechnology is one of the five selected basic trends of the comprehensive program of science and technology progress in the CEMA member countries till the end of the century. Likewise, the program of long-term economic and R&D cooperation between the CSSR and the SSSR till the year 2000 emphasizes the development and launching of biotechnology as one of fields of preferential orientation of R&D cooperation.

The primary importance of biotechnology for the national economy and the whole society equals the importance of atomic power engineering for ensuring energy or of electronics for modernizing the entire technological processes, such as computerization, control and technical level of mechanical engineering products. It is necessary to approach the solution of these problems resolutely and without hesitation. Therefore, in October of this year, the CSSR Government adopted a long-term comprehensive R&D program of development and realization of biotechnology in the CSSR.

The target of this program is unequivocal; it should ensure, expeditiously, in the shortest time possible and on a high level, the industrial implementation of biological processes in agriculture, food industry, health care and pharmacology. The problems of biotechnology are broad and multiform; they relate to many fields of basic and applied research and to development of specific technologies, as well as to sections and fields of research, development and construction of equipment and production assets.

The principal responsibility and the largest share of biotechnology development objectives fall to basic research, as in the rest of the world. In our country, it means primarily institutions and workshops of the Czechoslovak Academy of Sciences and the Slovak Academy of Sciences. The administrators and researchers of these top scientific institutions are responsible to provide, in their planning and their goal-oriented programs, for priority solutions of problems connected with the development of biotechnology; consistent control of the fulfillment of all objectives closely related to accelerated transfer of the results to applied research, to development and verification operations is of equal importance.

It will be absolutely necessary to avoid all errors and deficiencies of past years. Although we can say that increased attention has been paid in our country to research objectives relevant to biotechnology solutions already at the end of the seventies and beginning of the eighties, we cannot, so far, be fully satisfied with the results. In some managing R&D bodies and also in practice, the biotechnology processes were often considered as fashionable research trends.

An important step to overcome such ideas were the decisions of the Czechoslovak Government presidium from 1980 and 1983--on programs of integration of biochemistry and chemistry into animal production, comprising already many biotechnological elements, and another decision from 1982 on development of biological technologies.

As a follow-up to this decision, a set of measures on developing biotechnologies was elaborated; 30 of the 48 stipulated objectives have already been implemented in practice.

Many of the introduced biological processes or concluded research tasks are not only effective in the production, they are replacing costly imports from capitalist countries as well. The more is it necessary to fulfill, in the near future, all set goals based on long-term comprehensive R&D program of biotechnologies.

The proposed plan of objectives resulting from the long-term comprehensive program anticipates to develop research and realization of biologic technologies in six principal directions. To ensure them, the efforts of the scientific research base are concentrated in five goal-oriented projects of basic research. One of them, for instance, is the goal-oriented project called "Technology of Genes Manipulation"; its results will be used in practice in the domain of human and veterinary medicine, in pharmaceutical industry and in the food and agro-industrial complex.

Another goal-oriented project is "Microbiological Processes"; it will create the prerequisites for a broad development of microbiological industry, for utilization of biotechnology in agriculture, food industry, health care and other fields, as well as in environmental care. It will include fermentation production of feed proteins, amino acids, antibiotics and various feed complements, as well as bacterial and other fertilizers. In the food industry, it will involve, among other things, technology innovating the standard production of alcohol, yeast, vinegar, dairy products, and also a completely new production technology of proteins, enzymes, etc.

There is also a broad possibility for its application in health care, in the production of antibiotics, vitamins, immunomodulators and other biologically active preparations. The products of the microbiological industry will be applied, for instance, by means of technical enzymes in the production of textiles, tanning agents and lubricants and in many branches of chemical industry.

Also important is the contribution to the protection of the environment during the process of biological treatment of industrial, agricultural and urban sewage, microbiological breakdown of plastic substances or elimination of methane from the air.

Other goal-oriented basic research projects also include objectives which should result in creating prerequisites for the development of a broad scale of biological processes.

The development of biological technologies puts high demands on researchers in applied and basic research of several disciplines of biology, natural sciences and technology. The practical implementation of bold aims is, however, unthinkable without technological equipment demanding high quality materials which must be furnished by the metallurgy, mechanical and electrical engineering industries.

Thus, not only the comprehensive program of controlled development of numerous biotechnology processes is involved, but comprehensive participation of many branches of national economy as well. Without such joint participation and collaboration, it is impossible to fulfill the set tasks and goals. Another, equally important prerequisite is international collaboration, both R&D and cooperative, with the CEMA countries and especially with the Soviet Union. It will require a cooperation in R&D of necessary equipment, measuring and control systems and, last but not least, in educating the leading personnel.

As a rule, the biotechnology processes are not very energy intensive and we have at our disposal enough input raw materials from our own resources; as closed, usually wasteless technologies, they are environment friendly. On the other hand, they are extremely effective and enable export of the final products. The comprehensive program of their development is indeed of key importance to further development of our national economy.

12707/8309

CSO: 2400/130

SCIENCE AND TECHNOLOGY

GERMAN DEMOCRATIC REPUBLIC

PROGRESS SEEN IN REFINING OF METALLURGICAL RAW MATERIALS

Leipzig NEUE HUETTE in German Vol 30 No 9, Sep 85 pp 321-329

[Text] The strategy of higher refinement of raw materials and other available materials is one of the main trends on the way to further transition to comprehensive intensification. In the field of metallurgy three operational directions are characteristic. They are to be put into practice in a planned and consequent manner. These trends are:

--improving the quality of the products by increasing the using properties decisive for the user and final producer,

--lowering material consumption by accelerating the material-economic processes in all metallurgical states of production, and

--further implementation of the structure of production and transition to advanced stages of production in the manufacture of products.

In the course of developing metallurgy into an increasingly pronounced refinement metallurgy, the turn toward an intensive expansion of reproduction was completed in steps, and this is increasingly reflected in the conversion of intensification into economic growth. Continuing along the path of the transition to an extensive intensification, to a qualitatively new stage of economic development, the strategy of higher refinement of available raw materials and energy resources, has assumed a central role.

From an analysis of economic development in recent years, it turns out that it is quite possible to increase production and national income while simultaneously decreasing the consumption of economically important raw materials and energy carriers. This finding applies to the increased consumption of rolled steel. In 1978 the GDR consumed 6.8 million tons of rolled steel, but in 1984 after considerable increase in output, only 5.8 million tons were consumed. The absolute reduction in the consumption of rolled steel became in recent years a material condition for the continuing growth in production of end products and thus simultaneously contributed to the acceleration of economic growth, to increasing the national income. If we use the absolute rolled steel consumption and the material consumption code (MES) for rolled steel as an example, and use a reference of M 1 million national income and examine economic development since 1960 (Fig. 1), then four characteristic stages of the development are discernable:

--In the period from 1960 to 1965, rolled steel consumption rose by about 1.5 million tons and developed faster than the national income--a characteristic of extensive economic development.

--In the period from 1965 to 1977, the absolute consumption of rolled steel continued to rise. Its development was regressive however, so that the specific consumption per unit of produced national income decreased.

--The year 1979 can be viewed as the year of a qualitative reversal in consumption. For the first time, an absolute decrease in consumption occurred, whereas the growth in national income remained stable. Thus it is evident that the effectiveness of all material-economic measures, and above all those of the process of higher refinement of available iron raw materials, increased national economic end products.

--In following years, a trend toward reducing consumption continued and the annual rate of reduction increased. Thus the reality of the economic strategy oriented toward a high economic growth with falling consumption of important raw materials was reinforced for the long term.

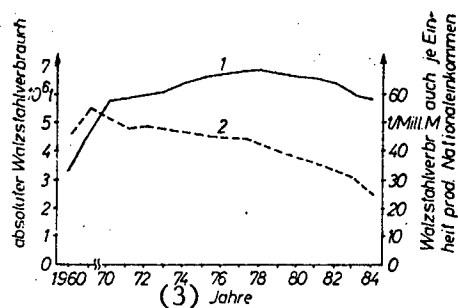

Figure 1. Development of Absolute Consumption of Rolled Steel (minus metallurgical consumption) and Development of Rolled Steel Consumption Per Unit of Produced National Income in the GDR

Key:

1. Absolute rolled steel consumption
2. Rolled steel consumption per unit of produced national income
3. Years

### 1. Goal and Content of Higher Refinement

In the determination of the goal and content of higher refinement of metallurgical raw materials it must be taken into account that the refinement concept has undergone change. As a technical category, it is as old as the use of natural substances in processes of extraction, processing, conversion, shaping, working and handling. To this extent, every production process to increase material consumption values uses a "refinement" of raw materials.

Refinement is thus in the general sense the transformation of raw materials into consumption values which lead to a greater satisfaction of demand.

Marx pointed out this requirement by stating that it is a matter of making better use of nature "both in order to discover new, useful objects and new uses for old ones; like new properties of raw materials, etc.; the development of science to its highest point..." (1) Marx is touching on the inseparable relation between scientific-technical development and the more perfect use of available natural resources.

In metallurgy, the refinement concept as a technical category was often used as a synonym for "material change of properties," which is always connected with a greater utility for the consumer. For instance, fine steels owe their designation to their particularly high use properties, like corrosion and acid resistance, heat resistance, wear resistance and high purity. The term noble metals is attributed to their outstanding corrosion resistance. The technology of surface refinement is similarly connected with the production of new material properties.

"In all these subsequent processes, the substance obtains a more useful form because it more resembles its consumption form, until it finally attains its final form where the consumption of the material and the termination of its form does mankind good, where its transformation is its consumption." (2)

Inasmuch as every production process is a process of refinement in which the worked object (in metallurgy the starting raw materials in the processes of processing, smelting, metal production, semi-finished goods and rolled steel production and processing into end-products in the 2d stage) receives ever new or improved properties which lend the worked product finally a greater consumption value.

What is the difference between the previous characteristic "technical concept" and the conceptual design and goal-specification of economic strategy of higher refinement?

Each production process represents a unit of work and value formation. The transformation from raw materials into new, consumption values is always connected with a consumption of both living and machine work. In the refinement from an economic viewpoint, it is not a matter of one-sided consumption values, but a question of how to get the greatest possible consumption value volume, i.e., a qualitatively better and quantitatively greater state economy end product, from the limited raw materials through qualified work using all experiences and powers of scientific-technical progress in all production stages?

From this, it follows that refinement must always be viewed as a process of increasing efficiency which leads to a significant improvement in the ratio of consumption value to expense in raw materials and energy, and whose breadth and depth is to be developed so that it increasingly becomes a decisive economic growth factor. Higher refinement is inherently connected with the

use of qualified labor--as the ability of real work--for converting raw materials in an efficient manner into products with greater consumption properties, and thus to form a constantly rising quantum of state economic end products which serve to better satisfy the demands of the population and the economy. So higher refinement is a process of increasing the demand-driven consumption value per unit of raw material. The achieved level of refinement can be determined in general form as the quotient of the consumption value of a product to its raw material consumption:

Level of refinement = Consumption value/raw material consumption

## 2. Methods of Higher Refinement and Increasing Economic Efficiency

From the preceding arise three working directions to increase economic efficiency through refinement:

### 2.1 Increasing the Consumption Properties of Metallurgical Products--Increasing Product Quality

Product quality means the "degree of suitability of the consumption properties of the product for the real consumption purpose."(2) Increasing quality as an expression of higher refinement can then be viewed as the ability of a unit of consumption value to meet a greater quantum of consumer demand. Thus, a complicated economic problem arises: In order to be able to quantify the consumption value of a metallurgical product which functions primarily as a working object to produce working tools, the question of what properties are decisive for the consumer must be answered.

How can the level of suitability, the utility of a metallurgical product be expressed in numerical terms?

First, one should note the difficulty that consumption values are known to be different; this is caused by different, real labor and cannot be easily summed up, in contrast to value quantities. In the development and production of 20 percent of new or developed metallurgical products each year, as a rule it is a matter of comparing existing and used products to new products of equal (or related) use, where a quantification of the increase in consumption value is possible in order to allow statements on the economic feasibility of the refinement.

In the analysis of economic effects from increasing the consumption properties through refinement, one must proceed from the specific metallurgical products. Metallurgical finished products are intermediates in the state economy. For the downstream industrial branches, they act as working objects and are destined for productive consumption.

Their utility is demonstrated in the additional processing steps as they become end products for the consumer through their processing properties and in their use by those consumption properties which decisively affect the consumption value of the end product.

Widely accepted in economic practice is the expression of product quality primarily through material and technological parameters. In the quantification of consumption value, very often we proceed from technical properties which are compressed via valuation methods into a dimensionless, high-aggregate quality characteristic, which finally should represent the product quality. This methodical procedure often serves to verify the results from the refinement and as a basis for pricing.

For comparisons of effectiveness for metallurgically refined products we find that such one-sided technical modes of consideration are not suitable for several reasons to express results of higher refinement in scale numbers.

The weighing of material properties and their compaction is largely left to subjective estimates, since such properties like hot and cold malleability, corrosion resistance, wear and hardenability, have quite different effects on the use value of the end products and their utilization conditions.

Metallurgical products pass through several production steps before they become useful end products. Through the process of division of labor, often highly branched production chains form. If one views the quality attained in the individual production steps as links in a chain, then the internal cohesion between the particular process steps can be expressed as a vector relation between input quantities of a particular process step and the output quantities of the preceding step(s):

$$a = f(n)$$

a Output vector with the quality characteristics of the particular product

n Input vector with the quality characteristics of the input material

f Process conversion

If a quality chain is analyzed backward from the final product, then one can frequently find that differences exist between the required vectors and the vectors available as preliminary stages. Because not all quality properties participate equally in the overall quality of a product, it also turns out that individual quality properties have a differing influence on the following steps and on the final product. For example, quality properties of metallurgical products can behave as follows:

--directly influence certain quality parameters of the final product,

--be lost over several process steps, but simultaneously affect individual quality parameters of the final product,

--exert an influence exclusively on the consumption production materials and the labor consumption and be more or less "consumed,"

--be lost without being used, since they are not needed either for the economy of the production process nor for the quality of the final product.

This then indicates that very often the quality parameters present in the preliminary material are not needed to their full extent. They embody a quality excess which corresponds economically to a waste of a certain quantity of expended work.

At the starting point of this discussion then, the following standpoint is taken: In the quantification of the useful value of refined products, or in the determination of the degree of utility over a comparison (basis) product, one may not merely list and evaluate the technical quality characteristics. Rather, it is important to cover the correlative relationship between improved processing and use properties and the economy of rolled steel processing and the utilization of the end products, within the framework of application investigations. The following principles apply:

--Improved processing and use properties are only economically relevant when they lead to a verifiable economic result in the process of processing and utilization.

--The production and use of highly refined products is only economically justified when one proceeds from the incorruptable scales of the economy, from the requirement to demonstrate the economic effectiveness of each scientific-technical action. Thus, for the management and organization of product development, it is necessary to determine measurable economic results from the valuation of higher refined products.

From consumption/use analyses and additional investigations on the effectiveness of refined metallurgical products, the following economic results can be derived which express the degree of utility from higher refinement and the improvement in use value.

## 2.2 Reducing the Consumption of Production Effort and Increasing the Output in the mvI Through Utilization of Improved Processing of Metallurgical Products

The influence of selected material shape and surface properties of refined metallurgical products on their processing properties is shown in Figure 2, the influence on costs and processing is illustrated in Figure 3. It must be taken into account that it is not possible to map clearly the individual properties to particular cost types in rolled steel processing.

The selected representation and allocation should approximately reflect the relationship between technical properties and economic relevance. As a rule, only in the processing of pilot quantities during application investigations is it possible to obtain reliable data on changing costs in the process step, while following the principle of comparability.

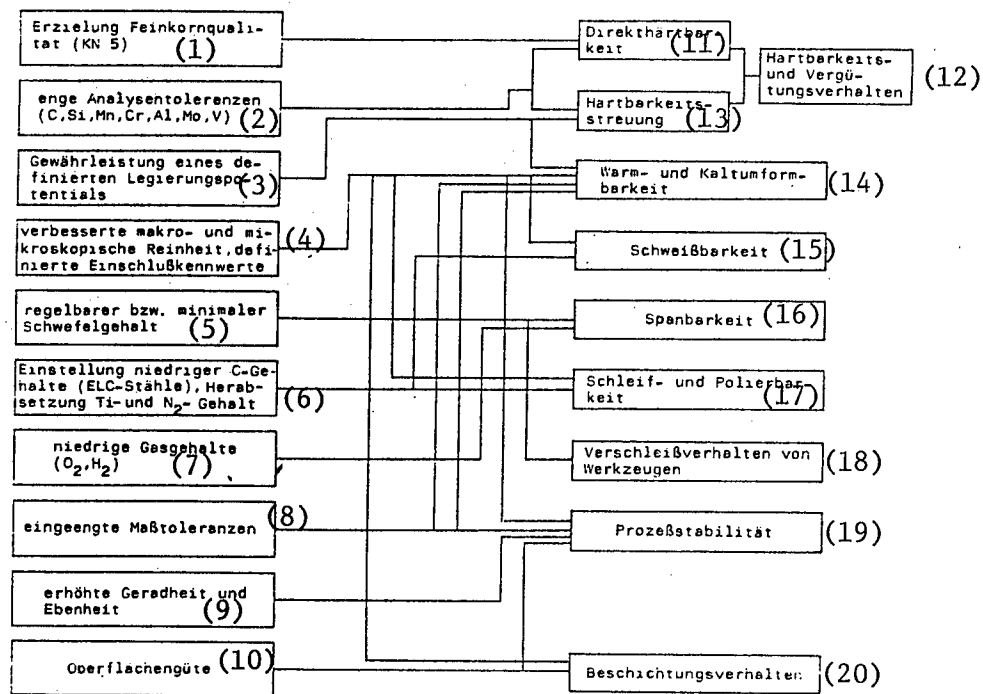

Figure 2. The Influence of Selected Material Shape and Surface Properties of Refined Metallurgical Products on Their Processing Properties

Key:

1. Achieving fine grain quality
2. Close analysis tolerances
3. Ensure a defined alloy potential
4. Improved macro- and microscopic purity, defined occlusion values
5. Controlled or minimum sulfur content
6. Adjustment of low C-content (ELC-steels), reduction of Ti and N-content
7. Low gas content
8. Reduced dimensional tolerances
9. Increased linearity and smoothness
10. Surface quality
11. Direct hardenability
12. Hardenability and annealing behavior
13. Hardenability scattering
14. Hot and cold malleability
15. Weldability
16. Millability
17. Grinding and polishing ability
18. Wear resistance of tools
19. Process stability
20. Coating behavior

In particular, the following items have to be investigated:

- Changes in base material costs,
- Savings in energy costs (by changing the thermal treatment),
- Savings in tool costs,
- Savings in wages and fixed costs arising from the increase in labor productivity, and
- Savings in waste, post-working, guarantee and test costs.

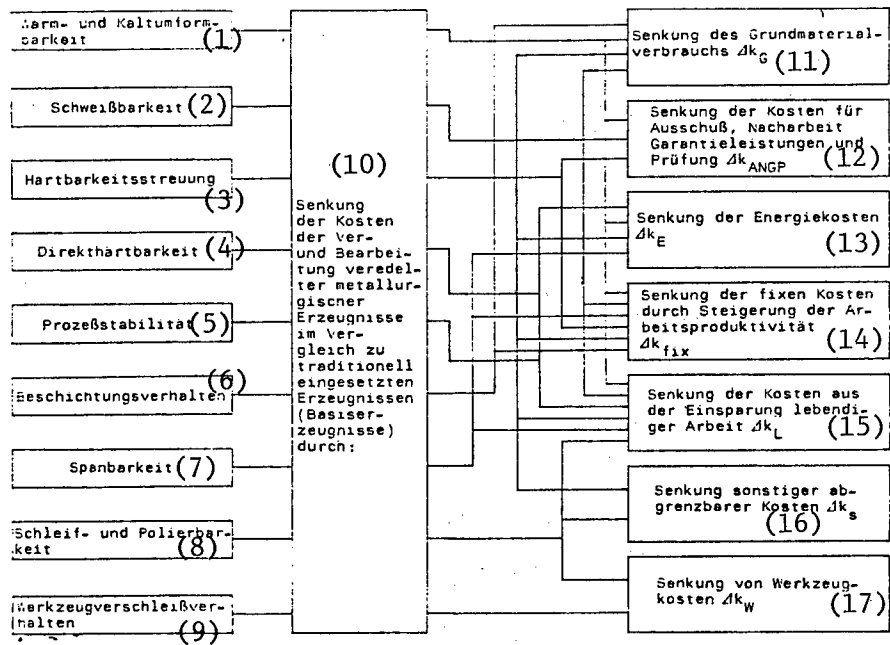

Figure 3. The Influence of Processing Properties on the Reduction of Costs in the Processing of Refined Metallurgical Products Into Intermediates and End-Products

Key:

- |  |   |
|--|---|
| 1. Hot and cold malleability   | 11. Reducing base material consumption                                  |
| 2. Weldability   | 12. Reducing costs for scraps, post-working, guarantee work and testing |
| 3. Hardenability scattering  | 13. Reducing energy costs   |
| 4. Direct hardenability  | 14. Reducing fixed costs by increasing labor productivity               |
| 5. Process stability   | 15. Reducing costs due to savings in labor                              |
| 6. Coating behavior  | 16. Reducing other variable costs                                       |
| 7. Millability   | 17. Reducing tool costs   |
| 8. Wear and polishing ability  |   |
| 9. Tool wear behavior  |   |
| 10. Reduction of costs and processing of refined metallurgical products compared to traditionally used products (base products) due to |   |

### 2.2.1 Reducing Rolled Steel Consumption by Increasing Service Life and Reliability

The service life of components, assemblies and final products is largely dependent on material properties like toughness, fatigue limit, directional stability of mechanical properties, weldability, wear resistance, corrosion resistance and surface characteristics. A higher level of refining, which is reflected in improved use properties and causes a greater service life and reliability in the final product, thus causes a delay in the time for its replacement (Figure 4). So from an economic view, savings in rolled steel will result during the utilization period and in processing costs for the production steps of rolled steel processing and manipulation until the final product is produced.

Higher level refinement, which is reflected in a longer service life, is economically equivalent to satisfying a certain amount of social needs with a smaller volume of consumption volume. The effectiveness of these more highly refined work objects, which are distinguished by longer service life, has thus visibly increased. The rolled steel savings from increasing service life, relative to one year (kw.St) results from the formula:

- m        Steel mass per final product (in t/ME)
- VE        Use factor in processing of rolled steel into one ton of metal in the final product (in t/t)
- P(i)      IAP per t of rolled steel per type (j) used to produce a product with a longer service life LD(j) in M/t.
- PSchr     Spot price for scrap in M/t (assumed to be about the same for both types of scrap)
- LD(i,j)   Service life of products (i) and (j) in years

### 2.2.2 Reducing the Specific Rolled Steel and Energy Consumption by Improving the Mass-Output Ratio

Another goal of higher refinement in metallurgy consists in utilizing certain, higher use properties of the produced metallurgical products to improve the mass-output ratio of the final products.

The preparation of a broad assortment of rolled steel products with higher strength, improved toughness properties, more uniform and improved hardenability, improved magnetic properties and optimum geometry is an important prerequisite for the more effective utilization of the principle of a light economy. The reduction of the mass-output ratio can be caused basically in two ways:

--Reducing mass per product unit by using material-saving, refined assortments while retaining the performance parameters,

--Utilizing the improved use properties of metallurgical products to increase use-enhancing performance parameters (e.g., greater portability, higher working pressures and speeds, greater throughput).

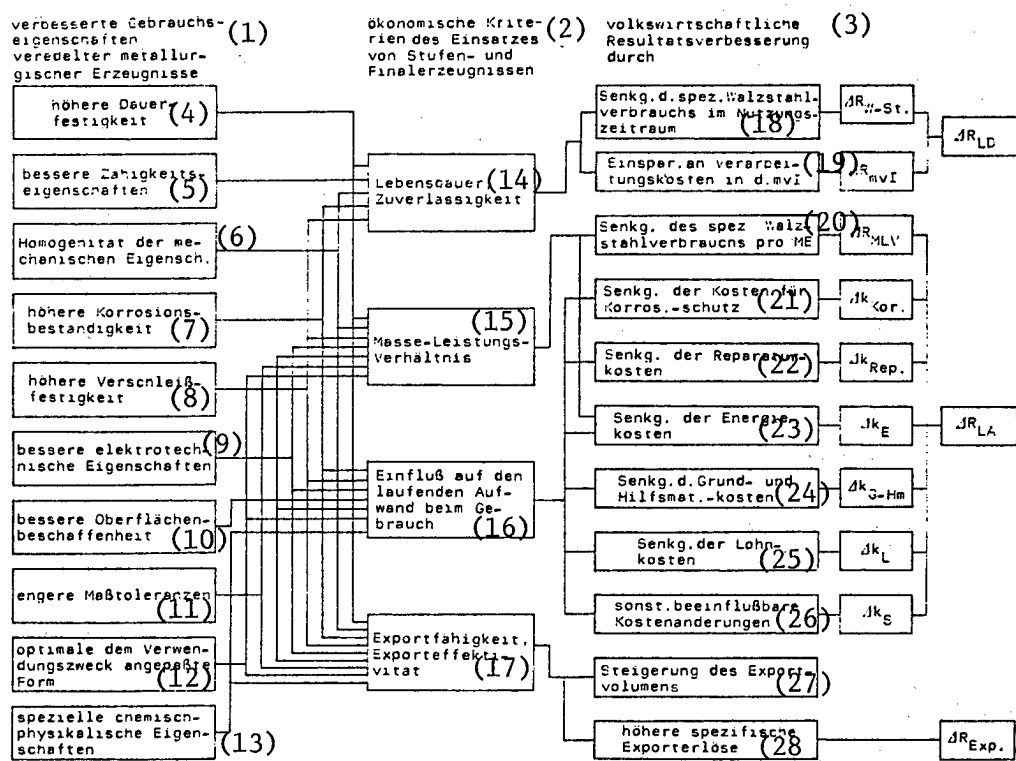

Figure 4. The Influence of Improved Use Properties of Refined Metallurgical Products on the Economy of Use of Intermediate and Final Products During Their Service Life

Key:

- Improved use properties of refined metallurgical products
- Economic criteria of the use of intermediate and final products
- Resulting economic improvement due to
- Higher fatigue limit
- Better toughness properties
- Homogeneity of mechanical properties
- Higher corrosion resistance
- Greater wear resistance
- Better electronic properties
- Better surface characteristic
- Closer dimensional tolerances
- Optimum shape for intended purpose

[Key continued on following page]

13. Specific chemical-physical properties
14. Service life, reliability
15. Mass-performance ratio
16. Influence on continuing consumption during use
17. Export quality, export effectiveness
18. Reducing spec. rolled steel consumption during utilization period
19. Savings in processing costs in the mVI
20. Reducing spec. rolled steel consumption per ME
21. Reducing costs for corrosion protection
22. Reducing repair costs
23. Reducing energy costs
24. Reducing base and ancillary material costs
25. Reducing labor costs
26. Other changes in non-fixed costs
27. Increasing export volume
28. Greater specific export profits

Both methods or a combination of the two, lead to a savings in rolled steel, relative to one performance or value unit. The indirect savings in rolled steel can be derived from the formula:

- Lj      Increased performance of the new or improved product
- Li      Baseline performance
- a      Proportionality factor which expresses the influence of the improvement in use properties of the used rolled steel on the relative mass savings; it must be determined for representative cases ( $a \leq 1$ )
- d      Digression exponent which expresses the digressive influence of increasing performance parameters on the specific product mass

### 2.2.3 Reducing Costs Incurred in Utilization

Higher use properties of the intermediate and end products--attributable to improved material and product properties of the finished metallurgical products--affect costs incurred during the utilization phase.

Since the predominant number of metallurgical products are used as construction materials for tool-making, the use value is expressed as a social power (as society need, i.e., it appears as payable demand) through "the quota of total social effort falling to the various production spheres."(3)

The lower the consumption of labor and machine effort in consuming the working material, the higher the economic effectiveness from the higher refinement in metallurgy.

Cost changes in the utilization process through the use of more highly refined metallurgical products, compared to using baseline products, can affect:

--Costs for corrosion protection due to higher corrosion resistance of use materials;

--Repair costs due to higher wear resistance;

--Energy costs through improved electrical properties (lower amagnetization losses when using premium dynamo and transformer plates) and by reducing mass of moving parts;

--Costs for base and auxiliary materials by reducing raw material and material losses when using high-precision machines or tools;

--Wage costs due to faster working speeds arising from better homogeneity of material properties, close tolerances and other factors positively affecting process stability.

The attainable and verifiable savings in the utilization phase must correlate with the improved utilization value of refined products, but it occurs quite differently, depending on the particular case. Thus it is indispensable to determine this relationship as accurately as possible for representative cases and to express this in numbers.

#### 2.2.4 Increasing Effectiveness of Exports

Previously discussed criteria do not apply to all those metallurgical products leaving domestic production for export to the nonsocialist world. The effectiveness of export is affected primarily by the level of use value of the exported goods, the national effort and external market conditions, and the price. The exchange of goods can contribute fundamentally to increasing, but also to decreasing the domestic national income. By utilizing national productivity advantages, the goal must be to gain much foreign exchange with little national effort through exports. An advantage in the external market can only be achieved when marketable goods of high quality are produced with a labor productivity which is above the international average.

This relationship was pointed out by Marx when he stated: "The average intensity of work varies from country to country; it is greater here, smaller there...Compared with the less intensive, the more intensive national effort produces more value in the same time, which is expressed in more money. But the law of value is modified yet more in its international application, since the more productive national effort on the world market counts as more intensive, provided the more productive nation is not forced by competition to drop the sales price of its goods to their value."(4)

The acceptance of the refinement strategy requires the development and sale of marketable products which provide significantly higher currency profits per consumption value unit, than previously exported products.

The real identification of the effectiveness of export production causes considerable difficulty. The legally prescribed method of computing export profitability as the quotient of export sales and expenditures for the export,

unsatisfactorily reflects the real economic result/effort ratio as an effectivity criterion. With this method, one essential component, the real economic value of previous import expenses--which is inherent in nearly all metallurgical export products--is left out.

To measure export effectiveness, an identifying number would be more suitable; it would compare the pure domestic expenditure (net domestic expenditure) to the net export profit:

$$E(\text{exp}) = \frac{\text{net export profit}}{\text{net domestic expenses}} = \frac{\text{export profit} - \text{import expenses}}{\text{inherent costs} - \text{import expenses}}$$

The net domestic expense can be formed as the difference between total inherent costs and the material and energy costs for imported raw materials and fuels.

The net export gain is formed from the difference between the currency gain converted to domestic currency, and the preliminary import expense.

The preliminary import expenses, in accord with the import structure, are:

- the iron content (steel scrap, pig iron)
- import alloys
- imported intermediates (steel band, semi-finished goods)
- metals and other substances for surface coating
- imported energy carriers (heating oil, natural gas, coke).

Higher refinement must be expressed in exports through increasing net currency gain per production unit and through a high effectiveness coefficient.

### 2.3 Reducing Material Consumption by Enhancing Material Economy

The ratio of use-value to expense in raw materials and energy can also be improved if the specific expense is reduced by economies in material and energy. This method of higher refinement should be used especially for those products where the use-value level corresponds to the economic requirements. For metallurgical production this development direction plays a great role for the following reasons:

- The production assortment of metallurgy contains a considerable fraction of those products not subject to any notable changes in use value. This applies, e.g., to products from unalloyed construction steels, steel for vending machines, hot and cold-rolled sheet metal, etc.
- Metallurgical production is characterized by a high material intensity. For example, the material costs for all of 1984 were M 72.46 per M 100 industrial goods production. The particular role of labor on the base material is shown even more clearly for the economy of the production process, when the coefficient of metal usage shown in Table 1 are analyzed in the primary production stages.

From the multiplicative linkage of use factors it turns out that in the overall state economic chain, 2 t of metal materials are needed to produce economic end products containing 1 t of steel.

Table 1. Coefficients of Metal Usage in the Main Production Stages of Rolled Steel Production and Processing

(1) Produktionsstufen	(2) Koeffizient des metallischen Einsatzes
(3) Rohstahlerzeugung	$V_1 = 1,106 \text{ t/t}$
(4) Halbzeugproduktion	$V_2 = 1,152 \text{ t/t}$
(5) Walzstahlproduktion (warmgewalzt)	$V_3 = 1,105 \text{ t/t}$
(6) 2. Verarbeitungsstufe der Metallurgie	$V_4 = 1,136 \text{ t/t}$
(7) Weiterverarbeitung (in der mvl)	$V_5 = 1,27 \text{ t/t}$

Key:

1. Production steps
2. Coefficient of metal usage
3. Pig steel production
4. Semi-finished goods
5. Rolled steel production (warm rolled)
6. 2d processing step of metallurgy
7. Additional processing (in the mvl)

Thus a significant leeway becomes visible for scientific-technical and management measures for reducing avoidable and technologically-caused metal losses. Experiences in recent years in the development of refining metallurgy confirm theoretical findings: The level of production machine usage is determined primarily by the consumption of working objects.

A differentiation is made in the production process by using the newest scientific-technical findings to apply new technologies on the consumption of raw materials and energy, and on the best use of investment capital.

Characteristic of this method for higher refinement of products, where no objective necessity exists to increase consumption value, is that in the process of higher refinement by reducing the consumption of production means, the total expended work drops in relation to the production unit, and thus no value increase occurs, but rather a value reduction. This value reduction may indeed be viewed as a fundamental characteristic of higher refinement.

The saved and relieved machine work acts as a new source of raw material and energy, i.e., as new working objects for the production of additional use value. In the final analysis, the economy of the material will create the material basis to produce a greater quantity of consumable end product from one unit of

raw material and energy. Since the growth in production can hardly be based on an increased usage of raw materials and energy, the reduction in consumption must become the decisive source for economic growth, the decisive basis for increased output. A visible sign of this intensification is the further increase in the percentage of cast steel in metallurgy. By continuous casting, 12 to 13 percent more slabbing can be produced from the same amount of raw material (liquid steel), which can be used to produce additional sheet metal and bands. At the same time, the increased production causes about 2.5 GJ in energy savings per ton of cast steel. In this regard, all measures which lead to a further "leaning" of metallurgical products, especially those for producing optimum-size products, represent a tangible contribution toward higher refinement of raw material resources.

For the product assortment of "cold rolled sheet metal and bands" a further decrease in average sheet thickness, while also improving the size and shape accuracy and surface nature, can be viewed as the trend toward higher refinement. The economic dimensions of a reduction in average sheet thickness will be demonstrated by the following discussion:

An annual reduction in average thickness by 3 percent in a 5-year plan period on a scale of the EKO cold rolling plant will give an increased surface production of 25 million square-meters of sheet metal, which can be produced without using up any additional resources (hot band) to supply the state economy. From the analysis of the specific material usage in all production steps of metallurgical processing, it is visible that material utilization can be increased and additional material reserves opened up by further reducing production wastes, avoidance of excesses, reducing cutting losses, more effective use of occurring residuals. These are not just average values. In an analysis of metal cycles which begin with raw material usage in metallurgy and end with the output of valuable end products and return of secondary raw materials, significant sources of loss are often visible.

For example, in the production of heat conductor bands from steel X5CrAl15.5 using conventional technology, the material usage coefficient is 3.4 t/t. But if such bands are made in future by the smelt-cast-rolling method, then the metal usage can be reduced to 1.2 t/t.(5)

Finally, to reduce material consumption by avoiding all material losses occurring under real production conditions, one should look at the political-economic relationship between value and useful value. Useful values are created by real work. At the same time, a value is generated by abstract work, and the useful value is its carrier. According to Marx, "no thing can be value, without being a consumable object. If it is useless, then the work does not count and thus no value is formed."(6) This finding is fully valid for socialist production. Only the value of such products is realized when they meet the demands of the populace, the economy and the external market and are salable. Non-salable products are useless real work and also have no value. The wasted work was not abstract work. It did not contribute to the formation of new value.

Thus any wrong smelting, loss, production wastes, residues, partial sheets, second quality products do not embody demanded products and thus represent wasted labor.

The continuing competitive initiative of Zero Error Production relies on the desire not to waste any performed work.

### 3. Conversion of Production Structure and Transition to Production of Products of Higher Production Levels

The statutory trend toward improved quality on the one hand, and the reduction in material consumption on the other, together lead to contradictory developments. The reduction in material usage, e.g., via constant reduction in dimensions of metallurgical products and the increased use of light construction can lead to decreased operational reliability and reduced service life, which under some circumstances can cause the material consumption to rise beyond the reproduction cycle. The constant increase in the surface/mass ratio of light metallurgical products can lead to increased corrosion losses and shorter service life, unless surface protection is also improved.

The solution to this contradiction requires a constant renewal of products, the introduction of new technologies and qualitative conversions in product generations, which is often connected with a structural change and a transition to the production of products of higher production levels.

The greatest economic effectiveness of product innovation is achieved when new technology is used to increase the useful value of products while simultaneously reducing the consumption of production material.

The reduction in material consumption, the more rational the utilization of raw materials and energy resources, and increasing the productive effect of labor, are significantly affected by the social division of labor. With the future development and perfection of the metallurgy combines, the economic advantages from the concentration, combination, specialization and cooperation of production will be clearly enhanced.

The buildup of the oxygen blowing converter steel plant and the further expansion of the EKO into a center of broad, flat rolled steel products with a complete metallurgical cycle, decisively changes historical production structures and economic proportions. The productive force of the useful, real labor in an industry, metallurgy for example, will determine how much labor potential will be released to produce new use values or to solve other social needs. This advantage should be used even more to concentrate "production of the total worker combined on a long stepladder"(7) who "has eyes front and rear"(8) and thus does more than the single worker to solve the tasks of refinement.

The main product groups of metallurgy exert a significant influence on the economy in the production of valuable end products, and above all on the mess/output ratio, because of their different use values and inherent costs. The

production of wide area products (warm band, cold band, fine sheet metal, coarse sheet metal) is advancing faster worldwide, than the production of other rolled steel products. This tendency is attributable to the following causes:

--Wide area products form the most important material basis for increased transition to light metal construction of machines, facilities and steel structures, and open up potentials for reducing the specific consumption of rolled steel.

--The use of sheet metal and bands permits significant savings in processing costs for rolled steel users through high dimensional and shape accuracy, low cutting losses, high processing speed, elimination of labor-intensive steps of background handling and surface refinement when using coated sheet metal and bands, and by the possibility of a manifold processing by bending, profiling, drawing, pressing and welding.

--The production of wide area products, especially of wide band, has great production advantages over other rolled steel assortments. The shaping speeds on continuous warm band lanes is twice that of profile roller works, and the input mass and band mass amount to 5 to 10 times as much. These advantages of band technology allow high specific facility outputs and low processing costs.

Another trend consists in the above-average production increase of cold-rolled and surface-refined sheet metal and bands.

The development of the structure of rolled steel consumption is seen in Table 2.

The increasing transition to producing products of higher production levels as a characteristic of higher refinement is expressed in the super-proportional production development of production stage II of Table 3, and by the trend toward continual processing of wide area products into products whose shape, external characteristics and material properties are ever more adapted to their final consumption purpose.

In this regard we can point out the qualitative change in the role of work objects in the overall system of productive forces. The higher refinement through the generation of new use properties increasingly causes a transition of work objects "from a relatively inactive, unchangeable factor into a quite dynamic element promoting productive progress."(9)

The work objects fit ever better in their use properties and shape with the different requirements of end products, which must always lead to an ever greater multiplicity of products provided by metallurgy. If the more active function of work objects is stressed, then it is above all a matter of the more pronounced effect of work objects on the progress of work agents and consumption agents.

Table 2. Structure of Consumption of Primary Product Groups of Total Rolled Steel Consumption in the GDR (in percent)

	1970	1975	1980
Formstahl (1)	16.4	16.0	15.7
Stabstahl (2)	22.6	22.3	21.7
Breitflacherzeugnisse (3)	44.5	44.8	45.4
- dar. warmgewalzt (4)	29.7	28.1	26.0
- dar. kaltgewalzt (5)	14.8	16.7	19.4
Blankstahl und gezogener Draht (6)	7.0	7.3	7.4
Stahlrohre (7)	0.5	0.6	0.8

Key:

- |                       |                               |
|-----------------------|-------------------------------|
| 1. Shaped steel       | 5. Cold rolled                |
| 2. Rod steel          | 6. Blank steel and drawn wire |
| 3. Wide area products | 7. Steel pipe                 |
| 4. Warm rolled        |                               |

Table 3. Development of Metallurgical Product Production in the GDR From 1965 to 1983 (from [10])

	1965	1970	1975	1980	1983
Roh Eisen, einschließlich Hoch- ofenferrolegierungen (1)	100	85	105	105	94
Rohstahl, einschließlich Flüssigstahl für Formguß (2)	100	117	150	160	167
Walzstahl, warmgewalzt, ein- schließlich Halbzeuge für Pressen und Schmieden und für nahtlose Rohre	100	114	143	172	170
Erzeugnisse der II. Verarbeitungs- stufe, einschließlich Stahlrohre (3)	100	231	362	483	493

Key:

1. Pig iron, incl. blast furnace ferro-alloys
2. Pig steel, incl. liquid steel for casting, rolled steel, hot rolled. incl. semi-products for pressing and forging and for seamless tubes
3. Stage II products, including steel pipe

## Summary

The strategy of higher refinement of available raw materials is one main effort along the path toward a transition to extensive intensification. For metallurgy, three working directions are important:

--Increasing product quality by increasing decisive consumption properties of metallurgical products for the consumer;

--Reducing material usage by accelerating processes of material economy in all production stages;

--Perfection of the production structure and the transition to producing products of higher production levels.

## BIBLIOGRAPHY

1. Marx, K., "Fundamentals of Criticism of Political Economics," Dietz Verlag, (East) Berlin, 1974, pp 266, 312.
2. Dobry, U., Dissertation B, Freiberg School of Mines, October 1984, p 94.
3. Marx, K., "Das Kapital," Dietz Verlag, Vol. III, (East) Berlin, 1972, p 649.
4. Marx, K., "Das Kapital," Dietz Verlag, Vol. I, (East) Berlin, 1973, p 584.
5. Felgner, M., Thesis, Freiberg School of Mines, 1983.
6. Marx, K., [see (4)], p 55.
7. Marx, K., [see (3)], p 89.
8. Marx, K., [see (4)], p 346.
9. Buechner, M., WIRTSCHAFTSWISSENSCHAFTEN, Vol. 32, 1984, p 1147.
10. STATISTISCHES JAHRBUCH DER DDR [Statistical Yearbook of the GDR], Staatsverlag, (East) Berlin 1984.

Received for publication: 26 April 1985

9280

CSO: 2300/57

SCIENCE AND TECHNOLOGY

GERMAN DEMOCRATIC REPUBLIC

IMPORTANCE OF MERCURY, PRECIOUS METALS REPROCESSING STRESSED

Mercury Demands Better Reprocessing

Leipzig NEUE HUETTE in German Vol. 30 No 9, Sep 85 pp 337-339

[Article by Klaus Oppermann, Freiberg]

[Text] Currently the widespread employment of mercury in the fields of industry, agriculture, medicine and in households provides only a recycling ratio of a maximum of 5 percent in the GDR. This situation is unsatisfactory. The report says that notwithstanding the development of highly up-to-date recycling techniques being described, VEB Kombinat Metallaufbereitung (the special GDR factory for recycling metal) is, however, for the time being not in a position to reduce the high losses of mercury occurring in a variety of products unless it is granted the right of cooperation and co-decision in the distribution of metal funds, in this case that is precisely in the employment of mercury. To find the optimum degree of metal recycling is an urgent concern of the whole society.

1. Use of Mercury

1.1 General Trends

Mercury (Hg) affords numerous potential applications due to its physical, chemical and toxic properties (chloralkali electrolysis, catalyst in chemical synthesis, seed and wood etching agent, electronics/electrical, dentistry, medicine, pressure and temperature measurements, generation of noble metals). This broad usage has led to a high consumption of mercury and to the contamination of all areas of the environment with this highly toxic heavy metal.

The certain prognostication of damage anticipated for man and environment, the increasing of still available terrestrial resources and the resulting 4-fold price increase since 1978 have led to programs in many countries aimed at:

- mercury technologies;
- substitution of mercury in pesticides and pharmaceuticals, and
- maximum recycling and regeneration of used mercury.

The success of this effort can be seen in the reduction in absolute demand and in the increasing quantities recycled. Certainly mercury's applications have not been entirely replaced.

But for ecological and economic reasons, it is important to do the following:

--to minimize the non-regenerable, dissipated percentage of mercury;

--to allow the use of mercury only in those cases where regeneration is possible and economically realistic.

## 1.2 The Situation in the GDR

Table 1 shows the percentage distribution of mercury used in the GDR (in 1980). Just 4 percent of this mercury comes from regeneration by the State Combine on Metal Reprocessing and from dental residues which are processed in the VEB Bergbau- und Huetttenkombinate (Mining and Smelting Combine) at Freiberg. None of the mercury used by industry for production purposes finds its way into the recycling plants.

Table 1. Percentage Distribution of Mercury Used in the GDR (1980)

Industry, use	Fraction (%)
Chemicals, pharmaceuticals, pesticides	87.5
Electrical switches, electronics, lamps	6.0
Thermometers, barometers, measuring instruments Hg/glass	4.0
Other measuring instruments	1.0
Dental mercury, metal production	1.5

In past years activities had been developed which were to minimize the unrecoverable losses and the poisoning of the environment; these activities were based on the National Cultural Law, the Water Protection Law, the Natural Balance decisions, use restrictions and labor hygienic decrees. But the achieved status is by no means satisfactory. From Table 1 it is visible that the urgently needed restriction of mercury use in the GDR lies in minimizing the dissipated mercury.

## 2. Regeneration of Used Mercury

In principle, the chances for regeneration of a used raw material decline with its increasing dilution. Certain uses allow no regeneration at all, due to the maximum dilution. For noble metals, regeneration from materials containing only 0.05 percent is economically possible, due to their high value, but for mercury a minimum metal content of 5 percent is needed for economical regeneration. This comparison shows the shortcomings of the present price structure, since the ecological aspect is entirely ignored. Thus it would be desirable to promote the economical recycling of toxic, heavy metals by a "pollution tax."

The regeneration of mercury from the economically recoverable fraction must be viewed under two aspects. The companies using mercury and its compounds in their production (chloralkali electrolysis, catalysts, mercury-containing pharmaceuticals and medicines, etching agents, luminous tubes, mercury-vapor lamps) are themselves responsible for the recovery of mercury from their waste products (due to the originator principle); it is to be viewed as a component of the production.

But the problem is different for mercury used primarily in metal form in electrical switches, rectifiers, mini-cells and batteries, temperature and pressure measuring devices, which have found wide use in the economy, in scientific institutions, in health care, in households and in the private sector. In this case, the originator principle to prevent health, ecological and economic damage, can only take effect by obliging the user to collect and remove it.

The State Metal Processing Combine has responsibility for the collection and processing of these materials; naturally it needs the intensive support of all participants in this.

It is estimated that of the annual mercury consumption in the GDR, max. 5 percent can be recovered. All mercury used in chemistry, pharmaceuticals, pesticides, for luminous tubes and mercury vapor lamps, is in the final analysis lost; for electric switches, rectifiers, mini-cells and batteries, about 25 percent is recyclable, whereas the mercury used for thermometers, barometers and dental purposes can be 50 percent recycled. For dental mercury, a significant improvement in recycling is expected in the near future, with significant economic support from the accompanying silver. The State Metal Processing Combine has at present no influence on the use of mercury in the economy of the GDR and thus on reducing the dissipated fraction. There is also no right to participate in decisions affecting the technical-economic side of the recycling. The one potential consists in regenerating as much mercury as possible from the given, recyclable fraction.

This problem is of supreme importance within the complex responsibility of the State Metal Processing Combine for the metals fund of the GDR.

### 3. Status and Perspective of Mercury Recycling

The detection, collection, storage, transportation and processing of mercury and mercury-containing materials is subject to the regulations of ASAO 723/2 and the Toxins Law. Consequently, particular care is required. One of these requirements in the past consisted in concentrating the mercury-containing materials in one of the facilities run by the Leipzig Central Laboratory of the State Metal Processing Combine and to reprocess the old mercury into pure mercury. This concentration process is to be terminated in 1985 and all old mercury and mercury-containing materials within our jurisdiction will be processed and purified centrally. The needed facilities and equipment are presently in preparation.

The on-going activities have resulted in a three-fold increase in recovery between 1977 and 1984. This increase is due in particular to the significantly improved management of the combine and to the collection points to prevent mercury losses and the establishment of direct communication between the Central Laboratory and certain recovery sources. In the future, the State Metal Processing Combine will be able to collect about 20 t of mercury per year.

### 3.1 Organization of the Collection

The collection is based on TGL 37666 "Nonferrous metal scrap" (1) of the following types:

- 8418 old mercury with at least 90 percent metallic mercury;
- 8428 mercury-containing material with min. 40 percent metallic mercury;
- 8438 mercury-containing material with min. 5 percent metallic mercury.

The pricing of these types was designed to keep the collection centers from reprocessing it in order to prevent mercury losses due to improper handling. An information sheet "Old Mercury" serves to inform the collection centers. As a special service, the Central Laboratory of the State Metal Processing Combine offers to process non-transportable material, especially glass rectifiers, in situ. The invoking of this service must be requested via the cognizant MAB concerns.

Not included are luminous tubes, mercury vapor lamps and similar uneconomical reprocessing materials. But mercury compounds of all Class I and II toxins are accepted directly between offeror and Central Laboratory, in conformance with the Toxins Law. But these may not be production wastes. The transfer costs are paid by the processor.

The Leipzig Central Laboratory of the State Metal Processing Combine operates in the main area of mercury collection and can be consulted in all matters pertinent to this topic.

### 3.2 Transfer and Processing

The transfer of types 8418 and 8428 occurs by the particular MAB concern. By storing in steel bottles or unbreakable containers under water, mercury losses are generally prevented. The 8438 type is usually processed in situ or is handled directly between collection point and Central Laboratory. The type consists mainly of mercury rectifiers of glass or steel, ignitrons and similar equipment.

The processing of old mercury and all mercury-containing materials takes place exclusively in the Central Laboratory. The methods used for the reprocessing are described briefly below.

### 3.2.1 Metallic Old Mercury 8418

Old mercury is fouled with oil, glass and dirt. Before chemical purification, it is treated with detergents followed by filtration. These processes are performed with the mercury under water to prevent the generation of mercury vapors. The wastes are continually monitored for the presence of mercury. If there are considerable mercury contents, the waste is stored for one of the following processes.

### 3.2.2 Type 8428 Material

This material consists primarily of mercury, glass, soft iron, copper and aluminum and is processed in a sieve drum mill of special design so that an optimum separation of contained mercury takes place.

The reprocessing lane has the capacity to handle all type 8428 material generated in the GDR. Complicated technologies endangering both man and environment are no longer needed at the points of pollution generation, since the entire mercury content is recovered.

### 3.2.3 Type 8438 Material

This category includes rectifiers, ignitrons and other devices. The particular danger with this material is that the presence of mercury is often unknown due to carelessness or lack of information. Cases are known where torch cutting work on such devices have led to fatal accidents due to acute mercury poisoning. The responsibility of the operators for release of scrap is of tremendous importance for this material.

The processing uses a cold method, i.e., proper ventilation of the housing and removal of the mercury from suitable places on the devices. In future these devices will also be heated under vacuum to drive off the residual mercury and to assist the subsequent metallurgical processes.

### 3.2.4 Amalgams, Mercury Batteries, Ag:Zn-Batteries With Mercury

These materials are new to the recycling process. The recovery comes from previously unused sources and the new amount of used mini-cells from clocks, hearing aids, minicomputers and other electronic devices.

Amalgams are alloys of mercury with a number of metals, like Au, Ag, Cu, Sn, Pb, Zn, Cd. These amalgams can be broken down thermally or chemically. In order to obtain the metal, the primary method uses thermal extraction of mercury by vacuum distillation. Due to the complex composition of such materials, the obtained mercury must be handled chemically. This type of processing is also suitable for dental residues; the precious metal content requires small, discontinuous batches.

### 3.2.5 Mercury Compounds

Mercury compounds are among the Class I and II toxins (exception: HgS, Cinnobar). The processing of these chemical compounds, which also contain several toxic components, requires an appropriate method. Since there are relatively small quantities of these compounds, the processing and detoxification to obtain metallic mercury is performed on a laboratory scale.

### 4. Purification of the Old Mercury

All old mercury obtained from the above methods must be purified, i.e., impurities must be removed. The main alloy elements are Zn, Pb, Sn and Cu. Noble metals are found only in the smallest concentrations in old mercury processed by us. The usual method of purification proved unsuitable for the quantities processed by us. In particular, the generation of mercury-containing solutions and residues is very disruptive. Similar to steel refreshing by blowing pure oxygen into the melt, the Central Laboratory developed a method (patent pending) which allows the purification of large batches of impure mercury from all base elements. Thus it is possible to obtain purified mercury of 99.999 percent in one working step. The purification process is monitored by application of the most modern methods of analysis.

### 5. Conclusions

The regeneration of mercury by the State Metal Processing Combine has arrived at a level as good as any in the world due to numerous activities in collection and reprocessing. The present maximum return rate of 5 percent of mercury used in the GDR is unsatisfactory and requires improvement.

The economic importance of the State Metal Processing Combine also requires its inclusion in consultations on the distribution and use of the metal fund in order to prevent the wasting of valuable raw materials and to improve their recovery. This right of consultation is viewed as a significant element in the desired, complex responsibility of the Combine for Metals Recycling.

### Summary

The widespread use of mercury in industry, agriculture, medicine and households presently allows a maximum recovery of 5 percent. This state of affairs is not satisfactory. It is shown how the State Metal Processing Combine is not in a position to prevent the loss of valuable raw materials or to improve their recovery without being included in consultations and decision making in the distribution of the metal fund. The structuring of optimum metal cycles is a matter for the entire society.

### References

1. TGL 37666 "NE-Metallschrott" [Nonferrous metal scrap] v. 1.1.1981

Received for publication: 14 February 1985

### Electronics Scrap Yields Metals

Leipzig NEUE HUETTE in German Vol 30 No 9, Sep 85 pp 340-341

[Text] Among the longest-known metals are the two noble metals, silver and gold, which have been used for thousands of years primarily as jewelry and coins. Due to industrial development, their usage has shifted in recent decades. The high electrical conductance and low contact resistance of these noble metals led to their use as contacts in electronics. In these products, the platinum metals ruthenium, rhodium, palladium, osmium, indium and platinum are also used; they likewise are numbered among the noble metals. In electronics the noble metals are used primarily in high-current switching devices (including air-break contactors, power switches, circuit-breakers and relays), in low-current devices (measuring and control units and ADP systems) and in fuses.(1)

Due to the expenses for importing noble metals, their regeneration from these secondary raw materials has become very important today. Within the frame of an experiment on "Collecting Old Noble Metal Scrap," at the end of the 1970's an organization was developed to recover noble metals from the economic cycle for use in industrial, electronic products.

The goal of the investigations is to prepare a basic strategy for using this organizational form for maximum effectiveness. The question arose of what amortization scrap with noble metals will be included in future, and what method is to be used for their recovery.

For a practical organization of collection and processing of used scrap with noble metals, there are two methods available; the more suitable is to be used by every factory or user having used scrap containing noble metals (called collection point below). The decision between these two methods was defined in the Secondary Raw Material Decree of 18 June 1981 by using two terms for scrap: "Scrap is":

- a) Old scrap containing noble metals, i.e., products or parts of metal or non-metals, solid or liquid, containing gold, silver, platinum and platinum metals (palladium, rhodium, iridium, osmium, and ruthenium) in physical or chemical compounds, and which cannot be used by the collection point due to standard deviations or physical wear or aging;
- b) Scrap containing noble metals, i.e., old scrap as per letter a, which is suitable for recovery in an economical manner due to its minimum content of one or more noble metals and its physical or chemical properties.

This scrap does not include wastes and residues occurring for processors and users."(2)

Likewise anchored in the Secondary Raw Material Decree is that the old scrap with noble metals is to be delivered separately from other scrap to the cognizant metal processing concern, unless in situ processing is performed by the collection point itself after agreement with the State Metal Processing Combine. (2)

From this result two methods of collection and processing of scrap with noble metals. When using variant I "Centralized Purchase by the State Metal Processing Combine" the old scrap must meet at least the classification and technical conditions of Technical Standard TGL 37666. The old scrap collected and delivered to the cognizant metal processing concern has been manually processed in reprocessing centers of the State Metal Processing Combine.

In order to improve worker productivity in the reprocessing of base and noble metal scrap from electronics, instrument building and technical consumer items, a reprocessing center for noble metal scrap was created at Eberswalde in Berlin-Hoppegarten which has machine reprocessing capacities.

The object of an effectiveness comparison was to clarify the question of what types of old scrap should be processed by machine, and what types should continue to be handled manually. The basis of the comparison was two methods which describe the problem.

In the first method, it was assumed that it could be more economical to continue manual reprocessing of the scrap with noble metal fractions as per 9711, 9721, 9731, 9741, 9751 and 9761 TGL 37666, since machine processing would give lower yields. Only lower-metal scrap type 9771 would be processed by machine. This method was compared to a second variant, where all old scrap would be processed by machine.

In the effectiveness comparison of the two methods, the output quantity of silver was viewed as the economic result of the processing. The specific silver yield from one ton of scrap of a particular composition was related to the average specific, total costs of processing this ton of scrap.

As a result of the effectiveness comparison, the noble metal-rich scrap (types 9711, 9721, 9731, 9741, 9751 and 9761) will continue to be processed manually, as long as no higher noble metal yields can be provided by the processing plant. When using manual reprocessing of these types, both the specific silver yields in kg of metal per ton of scrap is presently higher, and the processing costs are lower.

The more difficult to process scrap, type 9771, should be processed entirely in the Hoppegarten reprocessing center by machine.

But it still had to be determined whether manual processing of the higher-quality scrap should also be performed in future at the Centers of the Combine for Metal Processing, or in the individual collection points. Method II of collection and processing of noble-metal containing scrap, "Direct Collection Point Processing Concern" included the possibility of having collection points process the scrap (while following legal regulations) and deliver enriched noble metal scrap to the processing concerns for noble metals.

In the case of proper performance of manual processing, one can basically assume that when using both methods, the noble metals are almost entirely detected and enriched in the noble-metal containing scrap. Thus the considerations on effectiveness can be reduced to a labor comparison to regenerate a quantity of noble metals from old scrap of equal composition.

The subsequent efforts for sampling and analysis in the processing concern for noble metals must also be included in the manual processing step. When using Method I for collection and processing, the costs for sampling and analysis are constant, since the metal processing concerns deliver the collected noble-metal scrap to the processing concern at regular intervals. But if a collection point decides to perform the collection and processing as per Method II, then additional expenses for sampling and analysis will be incurred.

As a result of these economic considerations of the discussed methods, the following conclusions are drawn for future performance of collection and processing:

--All used scrap with noble metals as per type 9771 must in future be delivered to the cognizant State Metal Processing Center. The processing will be performed by machine in the reprocessing center.

--Smaller collection points should be oriented toward delivery of all type 9711, 9721, 9731, 9741, 9751 and 9761 scrap to the cognizant metal processing concern. As long as machine processing cannot ensure a higher yield of noble metals, this scrap will continue to be processed manually.

--Only larger collection points which are able to properly and effectively perform the processing of scrap types 9711, 9721, 9731, 9741, 9751 and 9761, should continue to perform physical enrichment of this scrap.

The greatest reservations are seen in perfecting the management and in particular, in the intensification of the collection process.

In many factories and facilities there is at present insufficient knowledge about the occurrence and detection of this old scrap with noble metals. All existing organizational forms of information and training, as well as mass agitation should thus be used more than before in spreading the knowledge of collection of old scrap containing noble metals.

To increase the volume of secondary raw materials at the collection points, our socialist production structure must play a more active role in planning. In 1985 the collection points were required to sort base and noble metal scrap from electronics, scientific instrument building and from consumer goods. With this summarized mission, the collection points were not stimulated to sort and deliver the old scrap with noble metals. The resulting, increasing mixed processing in the central processing facility can lead to a drop in noble metal

recovery. Thus, a way must be found to collect noble metal-rich scrap types 9711, 9721, 9731, 9741, 9751 and 9761 separately from other scrap. Only then can the effectiveness of noble metal recovery be positively influenced and a maximum recovery be ensured.

#### References

1. Documentation on Noble Metal Recovery From Old Scrap. VEB Fahrzeug- und Jagdwaffenwerk "Ernst Thaelmann," Suhl 1982.
2. Decree for Combined Use of Metal and Refractory Secondary Raw Materials-- Secondary Raw Materials Decree (M) 18 June 1981, Legal Gazette I (1981) No 18, p 238.

Received for publication: 8 April 1985

9280/8309

CSO: 2300/57

SCIENCE AND TECHNOLOGY

POLAND

PROCEDURES FOR RAIL SHIPMENT OF HAZARDOUS MATERIALS DETAILED

Warsaw EKSPLOATACJA KOLEI in Polish No 7, Jul 85 pp 159-161

[Unattributed article: "Conveyance of Hazardous Materials"]

[Text] The conveyance of hazardous materials by rail requires using special precautions in view of the danger of explosion, fire, poisoning or radioactive contamination of the area.

Hazardous materials include:

- explosives;
- compressed and liquefied gases as well as gases diluted under pressure;
- combustible and spontaneously combustible liquids and solids;
- materials that react with water to produce combustible gases;
- oxidizing materials that sustain combustion;
- organic peroxides;
- toxic materials;
- corrosives, repellants and contaminants;
- radioactive materials.

Depending on the nature of the menace involved, hazardous materials are divided into three groups:

- group A, particularly toxic materials that are of maximum toxic danger as well as radioactive materials;
- group B, explosives and toxic materials other than those in group A;
- group C, other hazardous materials (not included in groups A and B).

In view of the special properties of these materials the railroads accept them for shipment subject to special terms.

The consignor is obligated to adhere to specific provisions governing packaging and loading and to label and mark the shipment with appropriate warnings.

Hazardous shipments are carried in covered and open boxcars, tankcars and cars especially adapted for carrying a given material.

The rolling stock should be properly cleaned and sealed, and metal parts that are not parts of the structure or permanent equipment of rolling stock should not project inward. Rolling stock assigned for loading with hazardous freight should be thoroughly examined by a rolling-stock inspector.

Loading and unloading should be performed on a siding. If it becomes necessary to perform loading operations in the area of the station itself, or if demurrage of rolling stock carrying hazardous freight is necessitated, this should take place on especially designated station trackage identified in the station's manual of regulations.

Acceptance of a hazardous shipment for conveyance is performed by a railroad employee in the presence of a representative of the consignor.

He should check the correctness of the loading, packaging and securing of the shipment as well as the technical condition of the rolling stock.

How is the Shunting of Hazardous Freight Performed?

Shunting should be performed at a safe speed of not more than 10 km per hour.

Coupling and uncoupling of rolling stock is permitted only during a stopover.

The shunting of rolling stock that carries hazardous freight may not be performed by one person alone.

Shunting may be performed after the traction vehicle, together with at least two buffer cars, is uncoupled from the rolling stock.

Rolling stock carrying hazardous freight and, in certain cases, also empty rolling stock that had been used to carry hazardous freight, should be shunted with special caution. Shunting crews should adapt their operations to the warning labels and other markings on such rolling stock. If it ensues from these labels or markings that one or more particular uncoupled freightcars may not be shunted or rolled down from a hump, it has to be shunted with the aid of the locomotive coupled to them. Such rolling stock should also be protected against collisions with other rolling stock.

Rolling stock that carries explosives should be separated from a firebox-heated locomotive by four buffer cars. Crews of nearby stationary or passing steam locomotives should be notified about the shunting of such rolling stock, so that they may close the furnace and ashpit doors.

## How Are Trains Carrying Hazardous Freight Formed?

Rolling stock carrying explosive materials or objects, corrosives, toxic materials and compressed and liquefied gases as well as gases diluted under pressure, should be isolated by:

- at least six buffer cars, from an active locomotive and a firebox-heated car;
- at least three buffer cars, from the end car and the personnel-carrying car;
- at least two buffer cars, from boxcars loaded with elongated objects.

Rolling stock carrying explosives should be isolated by at least six buffer cars from rolling stock carrying corrosives and compressed and liquefied gases as well as gases diluted under pressure.

Rolling stock carrying readily combustible freight should be isolated by:

- at least four buffer cars, from an active firebox-type locomotive and from cars with furnace-type heating;
- at least four buffer cars from cars loaded with corrosives and compressed and liquefied gases as well as gases under pressure;
- at least two buffer cars, from an active non-furnace type locomotive.

No single train may include cars carrying:

- explosives and toxic materials;
- explosives or toxic materials and readily combustible materials;
- explosives or readily combustible materials and radioactive materials.

Rolling stock used as buffer cars or existing in direct contact with freightcars carrying the materials for which they are to serve as buffers must meet precisely the same technical and traffic requirements as buffer cars.

Rolling stock carrying explosives and the buffer cars in contact with them may not be braked, and their inactive brakes must be secured prior to coupling.

What trains are used to carry hazardous freight?

Hazardous freight should be carried on long-distance freight trains. Insofar as possible, they should be direct trains. A roster of trains earmarked for conveying particularly toxic materials is contained in Supplement No 8 of the Appendix, Part IV, to the Official Train Schedule.

What should be the personnel of the crew servicing a train that carries hazardous freight?

The train crew consists of:

-- a two-member traction crew plus the train chief -- only in the event that train contains explosives or carries a toxic shipment and the number of the cars carrying that freight exceeds 50 percent of the number of adjusted axles mandatory for a given train.

Is it the duty of the traffic dispatcher to notify the train crew that cars carrying hazardous freight are part of the train?

Yes, the traffic dispatcher uses a special "O"-order to notify the crew that the train contains hazardous freight and specify the precautions that should be applied in that case.

Should other trains passing the trains that carry hazardous freight be accordingly notified?

The general principle is that such notification (warning) is to be transmitted only in the event that it is required.

What should be done at a station when a train has to proceed by special order or following a substitute signal?

In such an event the special report to the traffic dispatcher on the properly planned route to be followed by that train should also contain information on the location of discrete switches and derailment switches on that route.

How should the train crew comport themselves during the travel of a train carrying hazardous freight?

It is the duty of the train crew, insofar as possible, to keep the rolling stock under observation; in the event any irregularities on the train are observed or reported on, the train should be stopped, on selecting a site with favorable terrain (or grade), uninhabited but accessible to motor vehicle traffic and thereupon, depending on the assessment of the situation, measures should be taken to prevent or minimize the damage.

It also is the duty of the train crew to immediately notify the traffic dispatcher at the nearest station about the danger.

What information should be contained in a report on an accident involving a train that carries hazardous freight?

The accident report should list the place, time, the number of the train, the nature of the accident and its consequences, and the needs for assistance and means of prevention needed.

What should be done by a traffic dispatcher who receives a report on an accident involving a train carrying hazardous freight?

The traffic dispatcher should close the track (or route) on which stands the train carrying hazardous freight, and notify the stationmaster, the sector

dispatcher (and, as the need arises, also organizational superiors of local line units of other services), the SOK [Railroad Security Service] and, as the need arises, the railroad fire brigade.

Who is obligated to provide aid if the accident results in a toxic hazard?

In this event specified chemical plants of the Ministry of the Chemical Industry are obligated to provide aid. Lists of the plants obligated to provide aid to PKP [Polish State Railroads] units are, together with the telephone and postal codes of these plants, contained in:

- Instruction R3 on Procedures in the Event of Railroad Accidents and Incidents;
- Instruction R18 on Abridged Numerical Addresses;
- Guidelines for Handling the Shipment by Rail of Particularly Toxic or Radioactive Materials (Appendix to Circular No CR3/80 of 4 July 1980 of the Ministry of Railroads).

Who Notifies the Chemical Plant of the Toxic Danger Arisen on a PKP Right-of-Way, and how?

The sector traffic dispatcher, upon receiving from the local traffic dispatcher a report on the accident, is obligated to contact by telephone, telegraph or other accessible means of communication, the nearest chemical plant of the Ministry of Chemical Industry, on using the emergency ("Ratunek") code number, and to specify:

- the accident site;
- the chemical (as stated on the bill of lading);
- nature and size of tare;
- nature of damage;
- the presence and nature of any other hazardous materials within the radius of danger;
- safe and convenient roads of access for the chemical rescue squad;
- name and position of person submitting the report.

Why is the conveyance of certain hazardous shipments monitored? What are the nature and purposes of the monitoring?

To enhance the security of the transportation of particularly toxic and radioactive materials belonging in group A, the duty of monitoring such shipments during their transportation on the PKP was introduced. Pursuant to the Ordinance of 29 December 1984 of the Ministry of Transportation (No CH10c-92000-22/84) Concerning the Special Organization and Conditions of the

Shipment of Explosives and Initiating Agents to Civilian Consignees, the duty of monitoring all explosives' shipments was imposed on traffic dispatcher offices.

The monitoring is performed by transmitting by phone information on the ongoing travel of the train carrying hazardous freight. The information transmitted includes:

- name of the substance;
- forwarding station (or frontier station);
- code numbers and number of freight cars loaded with hazardous freight (if there are five freight cars, the code numbers of the two extreme freight cars must be given);
- number of the train;
- consignee;
- destination (frontier) station;
- information on the progress or stoppage of the train.

The purpose of this monitoring is to take immediate rescue measures in the event of an accident.

Is the information transmitted during the monitoring of exceptionally hazardous shipments entered in technical and traffic records?

Yes, on stations designated for the reception and forwarding of hazardous freight, for its transfer to consignees and for other operations with trains carrying such freight, the station dispatcher keeps a special logbook (model No 2, in accordance with the Procedural Instructions for Railroad Units Obligated to Monitor the Rail Shipment of Particularly Hazardous Substances (DZIENNIK URZEDOWY, Ministry of Transportation, No 11, Item 89, with subsequent revisions).

The information recorded in that logbook specifies the hazardous materials subject to monitoring, the train carrying them, and the fact that station personnel was notified about the need to take special precautions when servicing the freightcars (or the train) carrying the hazardous shipment. Such a logbook is also kept by regional dispatcher's offices.

Where should the information on the travel of a train carrying hazardous freight subject to monitoring be recorded if a given station does not keep a logbook?

In this event the station dispatcher is dutybound to make a corresponding entry in the R138 logbook of telephone conversations.

Who transmits the information on the travel of a train carrying hazardous freight subject to monitoring?

The station which accepted for forwarding a shipment subject to monitoring notifies accordingly the regional dispatcher's office. After the route and number of the train to which the shipment is to be coupled are determined, the sector dispatcher notifies all the stations (Rsp) [expansion unknown] past which the train will travel as well as his counterpart in the next sector to which the train is transferred.

Do shipments subject to monitoring bear special markings?

Yes, the side-walls of a freightcar carrying such a shipment should bear a yellow rectangular label measuring 210x148 mm in area, edged in black and crossed by black diagonal lines. An identical label, the size of a regular postage stamp, should be affixed edgewise to the upper left corner of the bill of lading.

In addition, freightcars loaded with hazardous materials should be provided with other appropriate warning labels specifying the nature of the material transported. Tankcars designed for conveying particularly toxic materials should be marked with an orange stripe running alongside the tank cylinder.

1386

CSO: 2600/104

SOCIOLOGY

HUNGARY

#### FACTORS AFFECTING LABOR FORCE MOBILITY

Budapest NEPSZABADSAG in Hungarian 29 Dec 85 p 10

[Article by Marie Frey and Dezso Vass: "Factors Affecting Labor Force Mobility in Our Country"]

[Excerpt] Two Major Types

Labor force mobility has two major types: demographic change, i.e. youth taking the place of those retiring, and change of employers for those already working. This latter type is commonly called fluctuation. The changes that also alter the structure of the labor force--as to professions, occupations, branches, regions, etc--belong to the category of labor force mobility. Its importance reaches far beyond economic necessity. Labor force mobility is a manifestation of social mobility, and its extent is an important indicator of the openness of society.

Labor mobility touches masses of hundreds of thousands each year. During the past decade both the number of those taking new jobs and that of people leaving old jobs surpassed 1 million annually. In this process almost one fourth of those employed changes annually. About 25-30 percent of this can be explained demographically, including cases of maternity leaves and military drafts.

Demographic change is inevitable and unequivocally useful, as it plays an important role in diminishing the work force in regressing occupations, professions and regions, and in increasing the labor force in dynamic and progressive branches and occupations.

#### Evaluating Fluctuation

The evaluation of fluctuation, however, is not so clear and equivocal. Although a change of employers, also a sign of mobility, has a decisive role, even just by its sheer number, in altering the structure of the labor force. 700,000-800,000 people do it annually; on the average, every sixth employee. Although we do not have an objective standard by which to measure whether this is excessive or not, from time to time opinions are voiced that this fluctuation rate is unjustifiably high.

These statements single-mindedly overemphasize the national loss stemming from changing employers, considering fluctuation a distinctly harmful phenomenon.

The acceptance of this viewpoint colored the whole period of employment procurement, almost from the liberation till 1980. The objects of "punishment" were first those resigning and being fired, and later those changing jobs several times in one year. Today only those who do not work and pose a public danger are sentenced, but this is a legal matter and not an issue of labor force management. "Support"--in the form of recognizing that the change was legal, indeed desirable--was offered strictly to those who participated in the so-called "planned and organized" regrouping of the labor force. But according to the Information Center on Labor Matters their ratio comprises only 1.5 percent of all labor force mobility. Past experiences have duly indicated that legal sanctions on individuals' changing employers do not act as true deterrants, and in fact contradict the social value expressed in the right to freely change employers.

Efforts to administratively restrict individual freedom of changing employers are manifestations of in some ways still existing philosophy and practice that can be grasped through the concepts of centralized and administrative management. This style can be characterized by its demanding almost the same logic for all components of production, i.e. for distributing both live and embodied labor, even though they are fundamentally different in nature. In this philosophy, the fact that the individual has various socially recognized needs is merely an obstacle. For instance, such obstacle would be that the employee wants to change jobs "merely" because he wants to work closer to home, or because he wants to make more money.

#### Ways of Interest Enforcement

It is still not recognized or accepted that fluctuation is an important way for the employee to enforce his interests. Its intensity reliably mirrors how workers identify with their work and the organization, how their demands and needs are met through specific work opportunities, and how these opportunities gain economic and moral recognition. For this reason we cannot consider a change of employers "socially unjustified" if this is, for instance, how the individual gets out of bad working conditions, inconvenient work schedules or unfavorable negotiations on wage and productivity. In these situations getting out is a substitute for the lack of local conditions for change. Sanctioning individual changes of employers therefore cannot bring lasting improvement in the toning down of the intensity of fluctuation, but instead could distort the interest relations and interest enforcement between the social forces in plants and enterprises. Intensifying conflicts can only be avoided if we accept individual changes of employers as a rational system of indicators giving us information about the real causes of fluctuation.

Another possible way to influence labor force mobility is to regulate labor force demand. Efforts to this end can be classified into two groups: slowing down the demand for a larger labor force and measures aimed at distributing the labor force "rationally." For a long time these were accomplished through administrative methods that were later aggravated by a general labor force shortage. From the mid-70s on, a number of new measures were introduced to more gradually influence and control through the state the market conditions of the labor force that became freer around the introduction of the reform.

Of them, measures aimed at the administrative restrictions of labor force demands--for instance, a ceiling to the number of employees, hiring freeze for white collar jobs, reports to justify expenses of additional labor force for investments that required a loan, etc--were ineffective or only temporarily successful because instead of remedying the causes of labor force shortage they dealt with the effects only.

#### Role of Bargaining Position

But the measures aimed at a "rational" distribution of the labor force did not bring the desired results because in the absence of market selection favoring economic efficiency it was centrally decided criteria, changing from time to time, that was used--and not very precisely--to determine and aid labor force requirements of "economically important" branches and enterprises. The most glaring example of the application of hierarchy was the categorization of enterprises introduced in 1976. Contrary to previous criteria based on quantity, its goal in principle was to help provide effective and economically important enterprises with labor force. But the consequences of classification convincingly prove to us what kinds of interests were truly served. Nationally, large state enterprises became favored and smaller units were ordered to cut down on their labor force. Empirical research on categorization has shown that an attempt was not even made to consider efficiency in the process. Quite simply the demands of companies in a better bargaining position were accepted as justified. So instead of restricting labor force demand it sanctified the efforts of large units employing a significant part of all workers to increase their labor force. The best proof of the failure of this intervention is the cancellation of the measure five years after its introduction.

#### Change in Viewpoint

This step--along with cancelling several other administrative measures--is the result of a change in viewpoint that now more or less accepts the role of labor force mobility in the alignment of labor force demand and supply. Behind it are the following significant discoveries:

The intensity of the fluctuation is a phenomenon that cannot be evaluated by itself. Its frequently criticized high rate does not only cause "damage," but can be distinctly advantageous if it is caused by the economy's flexible adaptation to the world market.

Useful, superfluous and harmful changes in the labor force cannot be separated from one another as they may represent various dimensions of the same change in employment. Therefore differential regulation in practice is not workable.

It is impossible to evaluate the effectiveness of the economy in the jungle of subsidies and taxes. Therefore all efforts aimed at defining and detailing "desirable" directions seem illusory.

In the spirit of the above, measures have been brought to eliminate regulations restricting labor force mobility, and these regulations have been substituted

by methods of employment policy facilitating a more flexible adaptation to labor force demand and supply. As an example we may mention the updated version of the Labor Code coming into force in 1980. It gives more freedom than in the past to employers in adjusting as needed the size and composition of the labor force. In the same year employment procurement became a service with supplying labor force to enterprises in need of it and helping citizens find jobs as its chief goals. This was coupled with the establishment of a labor information system that continuously projects businesses' employment plans facilitating the timely recognition of likely tensions and preparation for handling them. Retraining subsidies have been introduced to help regroup labor force among and within enterprises. They are meant to relieve individuals from the negative material consequences of the inevitable occupational changes in the course of regrouping the labor force and to free employers from the forced burden of social considerations while reducing the work force.

#### Modest Interest

These measures are undoubtedly pointing in the right direction to enforce state responsibility for total employment. The current modest interest in them can chiefly be attributed to the lack of a system rationally enforcing economic efficiency and to the economy's deficiencies in labor force. An organic consequence is that an excess demand for labor force stays with us that on the one hand makes it difficult to impose stricter demands by employers on employees, and on the other hand makes changing jobs financially advantageous also for groups of people who would gain occupational expertise and a so-called knowledge of the organization only after a long time. Present power relations are accurately characterized by the fact that the overwhelming majority of changes in employment are initiated by employees. In 1983, for instance, only 2.9 percent of changes in employment were due to terminating the employee, while 59 percent were due to the employee's resignation.

We do not expect significant changes in the near future in the characteristics of labor force mobility. The current methods of employment policy are by themselves only able to correct processes inherent in the nature of the economy. A true step forward--affecting a more rational utilization of the labor force and its local aspects as well--can be expected from the complex and consistent perfecting of the process of economic reform. As a consequence we can expect new tasks influencing labor force mobility for which both labor management and research are preparing.

12366/7051  
CSO: 2500/144

SOCIOLOGY

POLAND

WARSAW ARCHDIOCESAN PRIESTS, BISHOPS CONVENE

Warsaw PRZEGLAD KATOLICKI in Polish No 41, 13 Oct 85 p 4

[Excerpts] The fall congregation of deans and vice-deans of the Warsaw archdiocese took place on 26 and 27 September. The site of the conference was the metropolitan seminary. Participating in the sessions were all Warsaw bishops, headed by Polish Primate Jozef Glemp, as well as officials of certain departments of the Warsaw Metropolitan Curia. The conference was chaired by Bishop Wladyslaw Miziolek.

Rev Jerzy Wasiak of Skierniewice, Rev Tadeusz Karolak of Zabki and Rev Jan Flazinski of the parish of the Conversion of St. Paul the Apostle in Warsaw became chaplains to His Holiness. Another nine priests were awarded the privilege of bearing the rochet, mantelet and ring. They are Rev Jozef Hass of the Warsaw Metropolitan Curia and pastors Rev Antoni Debkowski of St John Canti parish in Warsaw, Rev Henryk Drozd of Ostrowek, Rev Zygmunt Krysztopa of Duczko, Rev Jozef Mlacki of Janislawice, Rev Mieczyslaw Nowak of Golabki, Rev Jozef Olczak of Borzecina, Rev Jan Swierzewski of Otwock and Rev Taduesz Wasiluk of Kolbiela. A third group of honors was associated with transfers and appointments in the Lowicz's primate's chapter. Rev Zygmunt Dejcinski of Sochaczew was named dean prelate of the chapter. Rev Stefan Niedzielak, pastor of St. Charles Borromeo parish in Warsaw's Powazki district was named archdean prelate. Rev Bronislaw Stawicki and Rev Jozef Zawitkowski, both pastors of parish in Lowicz, became episcopal members and Rev Bernard Nieslony, pastor of the parish of the Nativity of the Blessed Virgin Mary in Warsaw's Leszno district, an honorary member. Rev. Boguslaw Bijak, director of the curia's Ministry Department, gave a report on "The need for a ministry to farmers in thge Warsaw archdiocese." In pointing out various shortcomings of today's villages, he encouraged the priests to give particular attention, in their pastoral work, to farmers, who number 17 million in Poland. He noted that the overwhelming majority of farmers is closely tied to the church and often anticipate help or support from it; therefore there is a need to establish pastoral communities of farmers for these purposes. They help enrich the spiritual lives of villagers, contribute to restoration of civil attitudes and can effectively counteract the outflow of village people to the cities.

The primate and several priests took part in a discussion after the report.

After praying the Angelus, further deliberations were begun, starting with matters of the Department of General Administration, discussed by Bishop Kazimierz Romaniuk, chairman of the department. The bishop also presented a report on the construction of the seminary in Bielany.

Bishop Jerzy Modzelewski, chairman of the Economic-Construction Department, reported on the state of church construction. Despite various difficulties and obstacles, construction is marked by great dynamism, the fruits of which are more and more new church buildings. The need to build 15 churches, 12 in Warsaw alone, between 1986 and 1990, was noted. Other announcements concerned the construction of chapels, religious education centers and convents. The bishop concluded economic-construction matters with an appeal to concerned Warsaw pastors to obtain the right of perpetual use for their parishes wherever this has not yet been done. The issue of difficulty in carrying on discussion with administrative authorities was also discussed.

Bishop Zbigniew Kraszewski represented three curia departments, monastic, Catholic education and sacramental affairs. The bishop gave a detailed account of the work of these departments and shared his observations on religious education of children and youth and parish records management. He also discussed the program of religious education and noted that educational authorities have decided to add to school curricula a subject called "religious studies." [---] [Law of 31 July 1981 on the regulation of publications and exhibitions, Art 2 item 1, 6 (DZIENNIK USTAW No 20 item 99, amended 1983 DZIENNIK USTAW no 44, item 204)]

The speech of Jozef Cardinal Glemp, primate of Poland, completely filled the fourth session. It covered issues of the entire church, the church in Poland and the Warsaw archdiocese.

In discussing matters of the church in Poland, the primate said that high level state policy toward the church is marked by a certain stability, but it is worse at lower administrative levels. The primate did not comment on the Sejm elections. He noted only that our society is pluralistic and every public act by a priest can be variously commented on and judged, depending on a given person's point of view. The determining factor of priests' conduct therefore must always be their own conscience and the awareness that they may not scandalize others. The primate concluded national topics with a discussion of the problem of the threat to the natural environment, which is particularly noticeable in Slask, Krakow, Lublin and Gdansk.

The remaining fifth and sixth sessions took place on 27 September. They were preceded by a mass for deceased priests celebrated by Bishop Zbigniew Kraszewski in the seminary church. Then all participants heard the speech of Archbishop Bronislaw Dabrowski on the state of the universal church and the church in Poland. The archbishop began his report with a discussion of the pastoral visit of Holy Father John Paul II to Genoa, after which he turned to issues raised during the recent deliberations of the Joint Commission. They dealt with the current socio-political situation in Poland and church-state relations. In this second set of issues was the matter of obstacles in church construction, pilgrimages, crucifixes, papal faculties, amended laws on education and verification of teaching personnel, local taxes and use of

cemetery and church grounds, the purchase of copper plating for convertible currency for covering church and religious education in sanatoriums and preventive centers. In supplementary comments, the primate brought up the matter of the credibility of the "Maitra" charity movement, while Rev Zdzislaw Krol informed those attending on the situation of imprisoned Rev Sylvester Zych.

12776

CSO: 2600/67

SOCIOLOGY

POLAND

ACADEMY OF SOCIAL SCIENCES RECTOR ON ROLE OF INTELLIGENTSIA

Warsaw ZYCIE WARSZAWY in Polish 9 Oct 85 pp 1, 2

[Interview with Prof Marian Orzechowski, rector of the Academy of Social Sciences and PZPR Central Committee candidate member, by Alicja Matynia-Bonik; date and place not given]

[Text] [Question] Five months have elapsed since the 19th Plenum of the PZPR Central Committee, which was dedicated to the role and place of the intelligentsia in the socialist development of the country and the requirements for intelligentsia work and operations. The Plenum also passed a resolution to create a Commission for Resolutions and Recommendations. On what is this Commission now working?

[Answer] The Commission was created to prepare a draft of a program to implement the party's policy on the intelligentsia. In valuing its role in developing scientific and technical ideas and culture and in enriching society's spiritual life, the party is striving to create conditions promoting greater involvement of the intelligentsia and the strengthening within it of a sense of responsibility for the country's future.

[Question] The concept of an intelligentsia is very broad, and the structure of this social class is very complex. Does this not make it more difficult to formulate specific recommendations to be implemented?

[Answer] The Commission is following a practical guideline in its work. We are leaving considerations on the social and professional structure of the intelligentsia to the scholars. The Commission's work is based on the material of the 19th Plenum as well as numerous opinions and proposals submitted to the Commission by party organizations, artistic associations and private individuals which will be included in the draft that will be discussed at the next Plenum, the 22nd PZPR Central Committee Plenum, which will be dedicated to resolving the various problems of social groups that are by tradition considered to be intellectual.

[Question] The 'intelligentsia' Plenum, as it is commonly described, satisfied some more than others. Do you think that the draft prepared by the Commission will satisfy intelligentsia expectations?

[Answer] I believe it will not only because it morally satisfies the intelligentsia as shapers of cultural, economic and civilizing progress, emphasizing its prominent position in society, but also because the draft includes specific proposals to improve intelligentsia material and living conditions and to improve laboratory equipment for the intelligentsia professional groups. As I mentioned, the draft will be discussed at the next Plenum, but from information received from institution directors, many postulates formulated at the 19th Plenum have or are being implemented.

In addition, it should be known that in preparing the draft, the comments of numerous intelligentsia organizations and associations, which were in response to a letter sent by the Commission chairman, Jozef Czyrk, Central Committee secretary and Politburo member, were taken into account. These organizations and associations include the Union of Polish Writers, Chief Technical Organization, Association of Journalists of the Polish People's Republic, Association of Polish Stage, Television, Film and Radio Actors of the Union of Polish Actors, Polish Medical Society, Association of Veterinary Doctors and Technicians, Polish Teachers' Union, Scientific Society of Organization and Administration, Association of Polish Lawyers, Union of Polish Authors and Composers of the ZAKR, Association of Polish Archivists, Association of Polish Medical Societies, Polish Free University Society, Association of Union of Actors and Theatrical Composers, Union of Polish Art Photographers, Workers' Associations of Culture Creators Group, Association of Folk Artists and Association of Science Writers.

[Question] What about the proposed solutions mentioned in the draft?

[Answer] For example, next year at least 2 percent of the national income will be allocated for scientific research and technological development, and in 1990 it will be 3 percent. This is almost a 2.5-fold increase in outlays for those years compared to the present 5-year period. The system mechanisms encouraging the application in the economy of new technological innovations are being improved by revising the legal and financial regulations regarding enterprise operations. The development of central programs as well as government requirements for research and development work are well advanced. Compensation will be linked more closely with professional work results achieved. Steps have been initiated to improve the relationship between the pay of production and non-production workers. The rules for compensation in scientific and research institutions and in scientific institutions of the Polish Academy of Sciences have been implemented this year. Pay scales for composers and journalists have been increased. And changes in the pay system for health workers and artists have been prepared.

Pay and working conditions for academic teachers and students' material conditions will be improved. With the new academic year, the first stage to increase academic teacher salaries has been realized, and the more favorable stipend regulations will be obligatory.

Work is continuing on the program for the future development of national culture. The Stanislaw Wyspianski Artistic Award for Young People has been created for eminent artists. This award, awarded already for the first time, encompasses 12 creative disciplines. Enterprises are now required to allocate

funds for worker participation in cultural activities. The program for 1986-1990 was approved that is supposed to improve health services. Among other things, foreign exchange funds to purchase medicines and semi-finished articles for the pharmaceutical industry have been increased. An initiative is under way to build 50 culture objects, movie theaters, houses of culture, libraries and in the largest working class areas to celebrate the 50th anniversary of People's Poland. Work on amending the "authors' rights" law will be completed such that an artist will be guaranteed proper living and working conditions for his artistic efforts. Efforts are being made to assure needed increases in paper supplies for press needs such that there will be 110 copies of newspapers and periodicals per resident by 1990. These are only some of the proposals contained in the draft.

[Question] Will the Commission be able to create the proper mechanisms to improve living and working conditions for the intelligentsia, especially teachers and artists?

[Answer] The Commission is an advisory body. The Commission will be dissolved the moment the program is accepted by the Central Committee. Then the program becomes an obligatory document for all party organizations and echelons and forms the basis for action by intelligentsia social and professional organizations and artist' associations. This program will be the basis for annual and multi-year government tasks designed to improve intelligentsia working and living conditions.

11899  
CSO:2600/72

SOCIOLOGY

POLAND

EDITOR ON NECESSITY OF MAKING CHOICES, REJECTING 'MYTHS'

Warsaw ZYCIE WARSZAWY in Polish 12-13 Oct 85 p 3

[Article by Zdzislaw Morawski: "The Language of Facts"]

[Text] Not too long ago an acquaintance of mine returned from a long trip abroad. He worked in his profession in the West under a contract concluded for such operations by a state enterprise. He earned good money and lived well. His wife and children were with him. He says that he made many friends and did not feel isolated at all, as frequently happens when living in a foreign country. He speaks highly, even sentimentally, of his working conditions, the beautiful scenery and good life. His employer wanted to extend the contract, which was agreeable to the Polish enterprise. But my acquaintance returned at his own request. I ask: Why?

Smiling uneasily and spreading his arms, he said that the time arrived to return home or, to put it simply, he and his family were homesick.

I think that the vast majority of Poles feel the same. We are curious about the world, and there are many Poles everywhere. We complain, often justifiably, about such or other conditions or affairs in our country, but we cannot manage to live elsewhere. And when we emigrate we write enthusiastic letters to relatives and friends, describing what can be purchased and how much money we earn. But in the evenings we cry over letters from Poland, the country we left voluntarily. We stick completely to the Polish ghetto, which is not always the most interesting place, and dream of all we left behind.

That is the way we are. After all, the words "mother country" mean more to us than to many other nations whose histories were much easier than ours.

That is the way we are, despite everything and all situations. The past years of upheavals, deep divisions, confusion, years of tensions, shortages and, for many of us, poverty confirmed this separateness, these specific national characteristics; confirmed that which is bad but also, and above all, that which is good.

Many times I heard foreigners state that if such a serious crisis, such deep divisions and such dramatic splits occurred in any other country, then a civil

war, large-scale bloody encounters, terrorism and its consequences would have been unavoidable.

Fully sharing this opinion, I believe that our separateness during that period was, paradoxically, one of the reasons why it was easy to spread false opinions about the situation in Poland in 1981 or 1982. Stories emanating out of our country during that time were conceived in the West on the basis of their own or other known experiences with military intervention in a country's public life, or various internal pressures and their consequences. And if Poland were not Poland, these consequences would look entirely different.

To illustrate, I would like to cite here a certain incident.

A well-known Italian journalist, who came to Poland during the first months of martial law, met with one of the leading party activists, a member of the PZPR Central Committee Politburo. Two days after the meeting, he ran into this activist, who was taking a Sunday walk in Lazienkowski Park with his wife and grandchild. The activist was unguarded. He told me about this later and expressed surprise, saying that in Italy this would have been completely impossible. He said that he himself travelled about Italy for some time in an armored car with a police guard because he feared terrorists looking for publicity.

In short, we are a gentle society, a good-hearted society, but very stubborn and not submissive. In Poland this affects the atmosphere of life, human relations and the behaviour of our leaders in many ways. Can we evaluate them honestly? It seems that the most recent difficult years forced us and are forcing us to do this more so than ever before. I believe that the constantly changing atmosphere in Poland is not only the result of changes in Poland's objective internal and international situations, a change for the better though slower than we wish and than is needed, but also the fact that we are beginning to draw conclusions from this self-evaluation.

What are the conclusions? Though maintaining much romanticism in public affairs and continuing to be a sentimental society, none the less we have become greater realists. The bitter though at times lofty experiences convinced us, to a greater extent than in previous decades, of the limits of what is realistic, possible and accessible as opposed to fantasies, political fairytales and dangerous myths. The boundary between that which is realistic and that which is illusory became much clearer in our minds, more precisely defined, though not to the same extent for all.

That is the first conclusion resulting from the experiences of the past few years.

If we knowingly reject all that is not and was not realistic, then we come to the same basic conclusion: we have progressed in the four postwar decades only by virtue of what we did or achieved through our own efforts here on the Vistula, Oder and Bug Rivers, and not in the most luxurious though distant and foreign lands; only by virtue of our own work and sweat, our own intellectual and cultural achievements, our own struggles against our own authoritative and rank-and-file blimpishness, rashness, naivete and at times plain stupidity.

However, the myths that formed the foundations for some of us or that at times were the basis for a program of action rose like foam, only to change into a few drops of dirty water. That is the way it was concerning the myth, launched immediately after the war by enemies of People's Poland, about Anders, who would come "riding in on a white horse." That is the way it was--of course, under other circumstances and seen from another perspective--with the previous government's program that projected Poland will be numbered among the most developed countries of the world thanks to Western credits. That is the way it was with the next, and the least enduring myth about the "second Japan."

Unfortunately, there were many more such myths. They did not strengthen our sovereignty nor make it easier to maneuver freely, but they did weaken our position in the world, to say nothing about worsening living conditions. On the contrary, our situation in all the mentioned areas became worse.

This statement is linked with a fundamental matter, that is: What choice did we have? We always had a choice. Of course, we could have defended the country's realistic interests, and many of us had actually done so in all the postwar periods. We could also support the myths. I do not have to remind anyone that at times such attitudes predominated or appeared to. The decision concerning what side to support--realism or blimpishness in its various forms--was linked with choosing a practical path, choosing a place in the world, taking a definite stand on our country's economic, social and political problems.

I am well aware that for some of us that even now, in a more peaceful atmosphere, such a choice is not an easy or unequivocal matter. But one must choose. Even when we take no stand because of passiveness or indifference we choose a side.

Making a choice is a very personal matter for every citizen. In making a choice, however, one must consider several basic, obvious truths that are not always perceived.

The first truth has been discussed already: all that serves us and our country is done here, in Poland, through our own efforts.

The second truth that we should become aware of concerns the relationships between the citizen and government. Often we think about how the government and its decisions affect our lives, our future and our material possibilities. But we think less often about the reverse dependence, that is, how our attitudes and our behavior affect us on a social scale, or what the government is and will be like, how it will behave and its possibilities. In his monumental work on the state, Plato wrote 25 centuries ago that a misunderstood, rejected government becomes worse and less willing to listen to the voice of the people and, what is more, inclined to limit its power. But a government able to convince its people of its good activities and that its program can be realized because of the people's support becomes a better government, more attuned to the universal will. Mutual respect exalts. A lack of respect and understanding diminishes, makes things worse. This statement is

one of the foundations of the government's new psychology, an area of knowledge that applies equally to rulers and society as a whole.

One last truth: there are people who say that we did not and have no choice, that our future is decided in some far off place, that we are like a pingpong ball that is batted about at other people's will.

With such an assumption, our public behavior is meaningless, neutral. But why is it that those who make such a statement, who suggest that we are incapacitated, also strongly urge us to behave in a specific way, that we cease treating both ourselves and the social mechanism functioning in Poland in an objective way, in a--let me call it--a consciously civic way?

Is it not because it is well known that their announced theme that we have no choice is false?

11899  
CSO:2600/72

SOCIOLOGY

POLAND

LATEST ISSUE OF 'ZNAK' REVIEWED

Krakow TYGODNIK POWSZECHNY in Polish No 41, 13 Oct 85 p 3

[Article by Jerzy Kolataj: "Plain Speaking"]

[Text] "In European social thought of the past two centuries there is always present a number of great themes which which every more or less Polish cognitive-ideological system has had to deal somehow and which in addition appear in countless loose statement: in the media, moralist discussion, literature and everyday discourse. Among them is the subject of 'individual freedom and government prerogatives' and the subject of 'what is a nation and what are its rights?'" Thus Jerzy Jedlicki begins his book entitled "What kind of civilization do Poles need?" The book has not yet appeared, although the State Publishing House for Scholarly Works [PWN] is to publish it soon, but Damian Kalbarczyk has read 500 pages of the manuscript and has written in the most recent issue of ZNAK that it deals with considerations of fundamental dilemmas in which Polish thought has been entangled since the end of the 18th Century and in which it is embroiled to this day. Culture or civilization, development in the spiritual realm or material realm, poetry or technology, insurgent impulses or a program of organic work--this is the one and the same question recurring in various ways in Polish intellectual life to the point of tedium.

This is not the place to repeat the opinions in ZNAK on a book that has not yet been published or to quote Jedlicki, the last chapter of whose book is also in the same issue, at greater length. For the sake of the reader's most general orientation, it is worth mentioning that these civilizational needs, simple and basic, have always appeared here as a register of mutually exclusive dilemmas and on their way to fulfilment have met with obstacles unknown elsewhere and totally incomprehensible to outsiders. "It has occurred to every decent European liberal and democrat," Jedlicki writes, "to call for universal compulsory education. But how was that possible here where schools had become an instrument of Russification and Germanization? It occurred to him to educate society in the spirit of respect for the law. But how difficult it was here where the law was a cover for political lawlessness." Poland had to become a barren abyss for any kind of civilizational ambitions or initiatives because for 200 years it had been destined to a continual choice between preservation of substance and and attempt at normal life. A choice of this kind could not be conducive to establishing mental balance for society

and so even its most "realistic" factions--we read in the article--did not always reckon with realities. This attitude is completely understandable in a situation "where on a political plane it had stood from the start in a losing position in comparison with the invader's power. Reckoning with the political system would have had to lead to impotence, apathy and discouragement; disregarding it led to illusions: to the illusions that 'one could democratize the social structure in a nation that did not permit any forms of political democracy'. . . to the illusions that one could cure the economy and civilize a country in which the law as well as the economy are dependent on decisions of a political nature. The positive heroes of 'What kind of civilization do Poles need?' live on just such illusions. The author admits this in the last paragraph of the book: 'Where the selflessness of intellectual leaders of democratism was to replace a non-existent nation and social reforms, where a censored article in a magazine was to replace a law, a voluntary contribution a tax for national goals, a secret workers' group a trade union, every attempt to fathom the future and moreover the will to create it, had to live on illusions. It could and must have seemed to the author of planning manifestos, over and clandestine, to social activists and agitators that they were waging a battle among themselves over who would seize the helm of history, on which course, formed by which doctrine, it would be directed. Indeed, under the watchful eye of the censor, policeman and spy, they quarreled obstinately over the hierarchy of values, over the meaning of generosity, over the ethereal shape of hope, without which the humbled nation grows stagnant in the desert of its daily existence.'"

When one reads this issue, one encounters at every step a hint of similar pessimism as the consequence of some unfulfillment. Jacek Wozniakowski's article, "Between the myth of nations and that which is everywhere," Marian Stala's comments on Przybylski's "Classicism," Tomasz Schoen's review of a book recently published by ZNAK, "In the Face of War," Skaradzinski's discussion of the life and work of Tadeusz Holowka (Iwo Werschler wrote a book about him; PWN; series: From the History of the Belvedere Camp)--all these positions, dealing with different times and very different issues, can be reduced to a common denominator by which one could acknowledge the pathological effects of the fact of gradual deprivation of Poles of their sovereignty in order to later divest them of their own nation.

After reading all the articles mentioned (and not mentioned) here, one understands in a completely different way the work contained in the preface of this issue by German theologian Ernst-Wolfgang Bockenforde, who last year, on the sixth anniversary of the pontificate of John Paul II, attempted an analysis of the main element of papal ministry and teachings on the mission and duties of the church in the world and for the world. The article is extensive; it was originally written for STIMMEN DER ZEIT (vol 198, 1984); ZNAK has printed, in Juliusz Zychowicz's translation, an expanded, modified version, made up of six chapters that require careful reading and serious consideration. Among these chapter, however, is one that strikes too directly at our current dilemmas not to call attention to it here. This chapter is entitled "The apolitical-political method of church influence on the world" and recalls basic issues that nevertheless often become the reason for numerous misunderstandings and fierce polemics:

"The church's mission in the world and for the world is a religious-theological and only a religious-theological mission," Bockenforde declares on the basis of analysis of many papal statements throughout the world. "In this sense the church is apolitical. It does not take a position on political goals, on maintaining or supporting political governments and systems, on favoring one side in political contests; it takes a stand exclusively and unconditionally on spreading the Gospel. . . . But because this mission is by its essence and by Christ's design a mission to the people and about man--about his dignity, freedom and ultimate destiny, the church, in propagating it and declaring itself in favor of it, by the nature of things affects people's lives and the order of their coexistence. In this sense, in fulfilling its mission, it works in an indisputably political way."

"The pope is concerned," we read, "that the church achieve the freedom of strict, undiminished, real dissemination of the Christian message of salvation." In the opinion of the article's author, in this message there are elements that point to particular, personal involvement by the pope. Among them are "protection of the rights and dignity of man, which have become his contribution through Christ. The church 'must speak plainly about injustice, exploitation of man by man or exploitation of the people by the state, institutions, the mechanism of economic systems. . . . It must speak plainly about all social injustice, all discrimination, all violence done to man, his body, his soul, his conscience or his convictions.' This plain speaking about rights denied man, human dignity impaired or not acknowledged, concerns not only present unfair actions, but also involves various threats to man by political, social and economic systems. . . ."

One could say that this "plain speaking about injustice" is not a matter of chance in this study. Poles know injustice not only in theory. They have experienced it for a long time and have felt it keenly as a wrong that obstructed their way to normal development and growth.

12776  
CSO:2600/67

SOCIOLOGY

POLAND

BRIEFS

NEW BOOK ON WYSZYNSKI--A book by Kazimierz Kakol entitled "Cardinal Stefan Wyszynski, as I Knew Him" has been published by the Trade Unions Publishing Institute. Publications devoted to the cardinal's work have thus far described mainly his pastoral work. Kazimierz Kakol's work primarily present facts and reflections on the primate's attitude toward Poland's socio-political reality. From 1974 to 1980 the author was director of the Office of Religious Affairs. But Kakol does not overlook other significant events in the cardinal's life. [Text] [Warsaw RZECZPOSPOLITA in Polish 4 Oct 85 p 5] 12776

DIOCESE DISOWNS PARISH PRIEST'S ARTICLE--[Communique of the Kielce Diocesan Curia] In the matter of the article by Rev S. Kudelski published in POLITYKA and SLOWO LUDU, the diocesan curia notes that: 1. The author published his article without the required knowledge and consent of the ordinary (Can 823 par 1, Can 831 par 1); 2. The author is not expressing himself in the name of the church and is not disseminating church teachings; 3. The substance of the published article is not consistent with church teachings, especially as regards the church's role in the world, marriage and protection of the life of the unborn. Bishop Jan Gurda, Bishop Mieczyslaw Jaworski, vicars general, 30 September 1985. [Text] [Warsaw PRZEGLAD KATOLICKI in Polish No 41, 13 Oct 85 p 4] 12776

IN DEFENSE OF RELIGION--The contention that religion is merely an artificial means of alleviating some inner emptiness or a false myth that draws a person away from the realities of life cannot be maintained today. It cannot be maintained if only because its "opium" is not inhaled by the nation alone but by hundreds of thousands of educated, intelligent people who are not forced into faith but who, on the contrary, choose religion consciously and voluntarily. Of course this is not evidence of God's existence but indirectly, why not draw such a conclusion? Another contention, that religion is meant to anesthetize the people, to turn their attention away from the injustices existing in the world, the division between rich and poor, to help control the multitudes of blindly loyal and exhausted workers, is ridiculously naive. Of course one cannot blame atheists if they do not understand the phenomenon of religion, for in reality they have no alternative but to ascribe an excessively naturalistic origin to religion and to treat believers as people who must be led out of error. [Text] [Katowice GOSC NIEDZIELNY in Polish No 42, 20 Oct 85 p 7] 12776

CSO: 2600/67

END