

AD

TECHNICAL REPORT ARCCB-TR-98001

**ELASTIC COMPARISON OF  
FOUR THREAD FORMS**

**G. PETER O'HARA**

FEBRUARY 1998

	<p><b>US ARMY ARMAMENT RESEARCH, DEVELOPMENT AND ENGINEERING CENTER CLOSE COMBAT ARMAMENTS CENTER BENÉT LABORATORIES WATERVLIET, N.Y. 12189-4050</b></p>	
---	--	---

APPROVED FOR PUBLIC RELEASE; DISTRIBUTION UNLIMITED

19980305 078

DTIC QUALITY INSPECTED 4

### **DISCLAIMER**

The findings in this report are not to be construed as an official Department of the Army position unless so designated by other authorized documents.

The use of trade name(s) and/or manufacturer(s) does not constitute an official indorsement or approval.

### **DESTRUCTION NOTICE**

For classified documents, follow the procedures in DoD 5200.22-M, Industrial Security Manual, Section II-19 or DoD 5200.1-R, Information Security Program Regulation, Chapter IX.

For unclassified, limited documents, destroy by any method that will prevent disclosure of contents or reconstruction of the document.

For unclassified, unlimited documents, destroy when the report is no longer needed. Do not return it to the originator.

# REPORT DOCUMENTATION PAGE

Form Approved  
OMB No. 0704-0188

Public reporting burden for this collection of information is estimated to average 1 hour per response, including the time for reviewing instructions, searching existing data sources, gathering and maintaining the data needed, and completing and reviewing the collection of information. Send comments regarding this burden estimate or any other aspect of this collection of information, including suggestions for reducing this burden, to Washington Headquarters Services, Directorate for Information Operations and Reports, 1215 Jefferson Davis Highway, Suite 1204, Arlington, VA 22202-4302 and to the Office of Management and Budget, Paperwork Reduction Project (0704-0188), Washington, DC 20503.

<b>1. AGENCY USE ONLY (Leave blank.)</b>		<b>2. REPORT DATE</b> February 1998	<b>3. REPORT TYPE AND DATES COVERED</b> Final	
<b>4. TITLE AND SUBTITLE</b> ELASTIC COMPARISON OF FOUR THREAD FORMS			<b>5. FUNDING NUMBERS</b> AMCMS No. 6226.24.H191.1	
<b>6. AUTHOR(S)</b> G. Peter O'Hara				
<b>7. PERFORMING ORGANIZATION NAME(S) AND ADDRESS(ES)</b> U.S. Army ARDEC Benet Laboratories, AMSTA-AR-CCB-O Watervliet, NY 12189-4050			<b>8. PERFORMING ORGANIZATION REPORT NUMBER</b>  ARCCB-TR-98001	
<b>9. SPONSORING / MONITORING AGENCY NAME(S) AND ADDRESS(ES)</b> U.S. Army ARDEC Close Combat Armaments Center Picatinny Arsenal, NJ 07806-5000			<b>10. SPONSORING / MONITORING AGENCY REPORT NUMBER</b>	
<b>11. SUPPLEMENTARY NOTES</b>  Presented at the 1997 ASME Pressure Vessels and Piping Conference, 27 July 1997, Orlando, FL. Published in proceedings of the conference.				
<b>12a. DISTRIBUTION / AVAILABILITY STATEMENT</b>  Approved for public release; distribution unlimited.			<b>12b. DISTRIBUTION CODE</b>	
<b>13. ABSTRACT (Maximum 200 words)</b>  Previously, this author introduced the concept that all screw thread forms have a structural "Characteristic Curve," which defines the basic stress concentration as a function of a radial stress in the joint. An additional set of characteristic curves is produced when the general stress field is considered. The standard analysis is for a single-thread tooth, isolated from a long chain of identical teeth, that is computationally efficient and facilitates the calculation of a family of characteristic curves. This work presents the characteristic plots for four different threads, the 7-degree British buttress, a 15-degree asymmetric "V," the 20-degree Benet buttress, and a special 30-degree "V." These four threads were selected because they are or may be useful in high pressure systems. Together they suggest the possibility of a standard thread family for high pressure applications.				
<b>14. SUBJECT TERMS</b> Screws, Screw Threads, Thread Forms, Threaded Connections, Stress, Stress Concentration			<b>15. NUMBER OF PAGES</b> 23	
			<b>16. PRICE CODE</b>	
<b>17. SECURITY CLASSIFICATION OF REPORT</b> UNCLASSIFIED	<b>18. SECURITY CLASSIFICATION OF THIS PAGE</b> UNCLASSIFIED	<b>19. SECURITY CLASSIFICATION OF ABSTRACT</b> UNCLASSIFIED	<b>20. LIMITATION OF ABSTRACT</b> UL	

## TABLE OF CONTENTS

	<u>Page</u>
ACKNOWLEDGEMENT .....	iii
INTRODUCTION .....	1
ANALYSIS .....	2
RESULTS .....	4
DISCUSSION .....	7
CONCLUSION .....	8
REFERENCES .....	9
APPENDIX A .....	11

### TABLES

1. Thread Geometry and Strength-of-Materials Stresses for a Pitch of 1.0 and a Supported Load of 1.0 .....	2
--	---

### LIST OF ILLUSTRATIONS

1. General geometry parameters .....	3
2. Characteristic plot for the 7-degree flank angle British buttress thread .....	5
3. Characteristic plot for the 15-degree flank angle modified "V" .....	5
4. Characteristic plot for the 20-degree flank angle Benet buttress thread .....	6
5. Characteristic plot for the 30-degree flank angle high pressure "V" .....	6
1a. Thread geometry parameters .....	12
2a. Characteristic plot for FRG buttress thread .....	13
3a. Characteristic plot for British standard buttress thread .....	14
4a. Characteristic plot for Stub ACME thread .....	15

5a.	Characteristic plot for modified "V" thread .....	16
6a.	Characteristic plot for Benet buttress thread .....	17
7a.	Characteristic plot for high pressure "V" thread .....	18
8a.	Characteristic plot for external "V" (UNR) thread .....	19
9a.	Characteristic plot for internal "V" (UN) thread .....	20

## ACKNOWLEDGEMENT

The author would like to acknowledge the work of Dr. Robert E. Weigle who directed the team that originally developed the Benet buttress thread. He used the Heywood equation as a guide and recognized the value of a larger flank angle.

## INTRODUCTION

The threaded connection is one of the more common methods of joining two components of an engineering structure. It is difficult to imagine a complex engineering structure that does not depend on threaded connections usually in the form of standard screws or bolts. However, in many cases the threads of the connection may be cut directly into a major component. This is the case for many pressure vessels such as cannon breech closures. The problem of safety and reliability of standard bolts is taken care of by the use of a system of national and international standards, which insure the proper fabrication and material of bolts manufactured within the system. The system is built around the 30-degree "V" thread in which the internal and external threads have a somewhat different basic shape, and the more critical external thread has stronger shape controls and a larger root radius. This works well in an environment with the internal threads cut in a rather large component with generally compressive stresses. This may not be the case for other structures where the basic stresses in either component are tensile and the size of the joint may be large compared to the overall structure. In these cases, both the internal and external thread forms may have to be designed as identical high performance thread forms, and other factors such as the radial stress generated by the joint may be important.

This report will explore some fundamental structural characteristics of four different thread forms. The first is a 7-degree pressure angle buttress thread known as the British standard buttress. It was probably developed by Dr. R.B. Heywood (ref 1) as a high-strength buttress and can be found in the breech closure of the 105-mm M68 gun. The second is a modified "V" thread with a 15-degree pressure flank and a 37-degree unloaded flank. This thread is of unknown origin and is found in a fixed joint of the 8-inch howitzer/175-mm gun breech. It is included here as an interesting example of a nonstandard thread form. The third is the 20-degree flank Benet buttress, which was developed at Watervliet Arsenal in 1962 by Dr. R.E. Weigle (refs 2,3) and has been used on all U.S. designed cannons since that date. Last is a variation of the MJ 30-degree "V" with a height that allows symmetry between the internal and external threads. The geometry and elementary stress analysis parameters for these threads is given in Table 1.

In this table, the fillet stress is taken from the work of Heywood (ref 1) and is the average of seven point loads distributed along the loaded flank of the thread. The stress concentration factor (SCF) is derived from the classic book by Neuber (ref 4) and is the average of an approximation for smooth and squared off notches. The bearing stress and shear stress are simple strength-of-materials calculations.

**Table 1. Thread Geometry and Strength-of-Materials Stresses  
for a Pitch of 1.0 and a Supported Load of 1.0**

	British Buttress	Modified "V"	Benet Buttress	30-Degree "V"
Primary Flank	7-Degree	15-Degree	20-Degree	30-Degree
Secondary Flank	45-Degree	37.15-Degree	45-Degree	30-Degree
Root Radius	0.1251	0.1360	0.1333	0.1501
Bearing Height	0.4000	0.4512	0.3394	0.4300
Total Height	0.5059	0.5520	0.4787	0.5152
Fillet Stress	8.646	6.897	5.941	5.036
Bearing Stress	2.500	2.216	2.946	2.326
Shear Stress	1.380	1.380	1.421	1.373
SCF	2.780	2.566	2.710	2.525

## ANALYSIS

This analysis used the finite element method to study the general effects of the following three factors on the fillet stress in a individual thread tooth:

- Stress derived from a uniformly distributed load on the loaded flank of the thread
- Effect of stress concentration from the general stress field of the component
- Fillet stress variation caused by changes in the friction conditions simulated by the uniform load

The analysis was done by the finite element method using the ABAQUS code (ref 5). The analysis models one tooth of unit pitch along with a 1.0 x 1.0 portion of an unspecified component. These have been loaded and constrained to simulate a single tooth in a long chain of identical teeth with identical loads. This method has been used by this author (refs 6,7) because it allows the detailed study of the different thread forms without confusing reference to any specific structure.

Any point load ( $W$ ) on a thread may be broken into vectors in the axial direction and in the radial direction (Figure 1). The axial vector represents the load being supported, in shear, by this thread tooth. This load may be averaged over the area on the pitch cylinder as an average load being transferred across the joint or the local "shear transfer." This is the nominal stress used for all plots and is always set to a unit stress value in the analysis. The vector in the radial direction is a reaction to the shear transfer and is also averaged over the pitch cylinder as a radial stress. This stress is a function of the constant wedge effect and the assumed friction vector. The friction vector can either point toward the thread fillet in a negative direction or point away from the fillet in a positive direction. A plot of the fillet stress versus radial stress produces a "characteristic curve" for any thread form. In this analysis, there were 41 load vectors applied, one for each node on the primary flank of the thread.

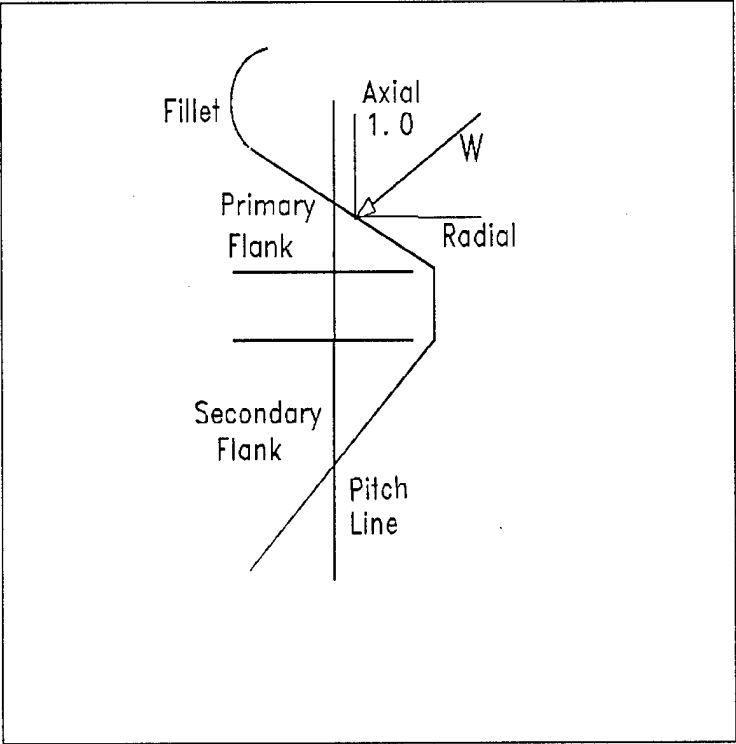

Figure 1. General geometry parameters.

Along with the stress due to the applied thread load, a thread also has an SCF in the general stress field of the component. This stress may be added to the stress from the applied thread load to produce a new "combined characteristic" curve. When the axial stress is nondimensionalized by the shear transfer, a family of combined characteristic curves is possible. For this report, the nine selected nondimensional axial stresses are -10, -5, -2, -1, 0, 1, 2, 5, and 10, which serve to define the behavior of the four threads in this comparison. To finish out the definition of the analysis space, the coefficient of friction will be varied from 0.0 to 1.0 in both directions. This should give a range that is greater than any practical problem.

All four models in the study were done as variations on the same rather large mesh, which was mapped into the correct geometry for the specific thread form. This mesh contained 920 eight-node axisymmetric elements and 2693 nodes. The mesh had 20 elements in each thread fillet that would produce good resolution of any reasonable stress distribution. Each thread was also given a pitch radius of 10.0 units that has been used extensively by this investigator as the smallest reasonable value.

## RESULTS

The results of this study are shown in Figures 2 through 5. Each figure contains a scatter plot of the basic Heywood results and a family of combined characteristic curves for the nine different values of the applied axial stress. The scatter plot serves two purposes: first it presents the basic Heywood results for the fillet stress with zero axial load, and second it provides radial stress marks at different values of the coefficient of friction. The scatter points are set at uniform intervals of 0.25, for the coefficient variation from -1.0 to 1.0, with the data point at a coefficient of zero (the value in Table 1) shown as a double symbol. In all cases, the plotted data represent the largest principal stress in the fillet, at that loading condition. The zero friction point moves to the left in successive figures, as the wedge effect of the larger primary flank angles becomes greater. The higher flank angles also tend to spread the plots over a greater range of radial stress and generally lower the stress at small values of applied axial stress. At high values (10.0) of tensile axial stress, the ordinary SCF tends to dominate and the characteristic curves become rather flat with a value between 26 and 32 times the shear transfer rate. On the other hand, at high values of compressive axial stress, the results become more complex and may produce a fully compressive fillet or the fillet may retain substantial tensile stress values. In some cases, the maximum principal stress may be affected by the proximity of the applied contact loads producing characteristic curves that do not seem to fit into the general family defined by other curves. This is always associated with a positive coefficient of friction and a negative value of axial stress.

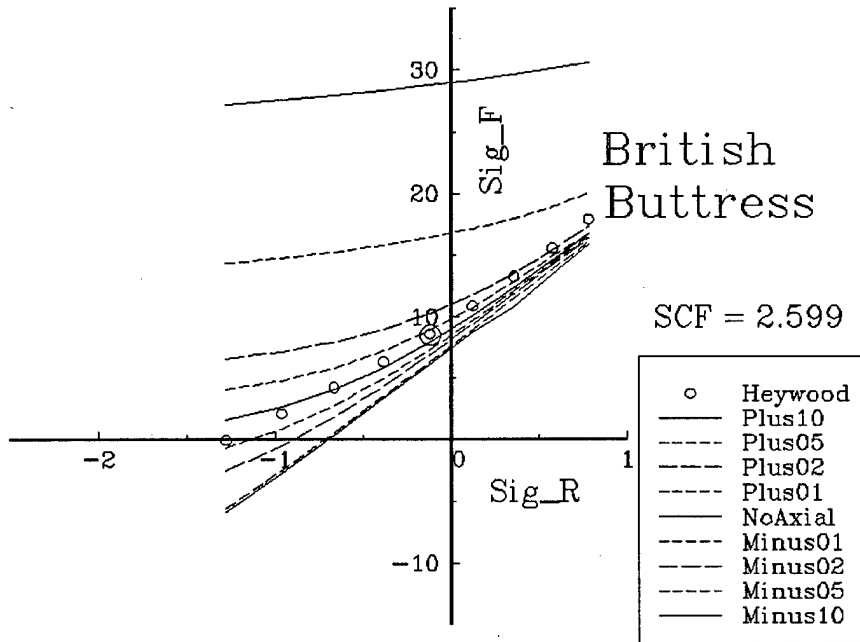

Figure 2. Characteristic plot for the 7-degree flank angle British buttress thread.

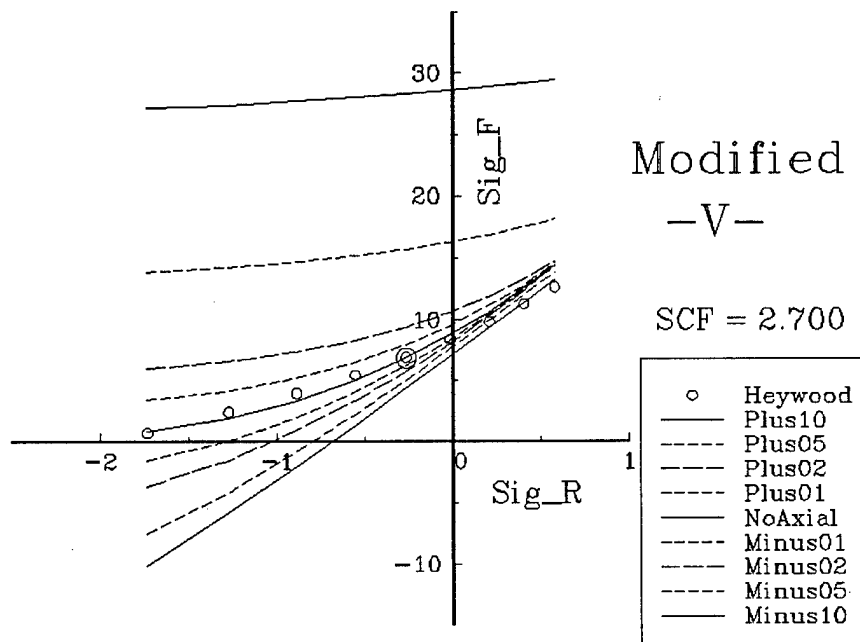

Figure 3. Characteristic plot for the 15-degree flank angle modified "V."

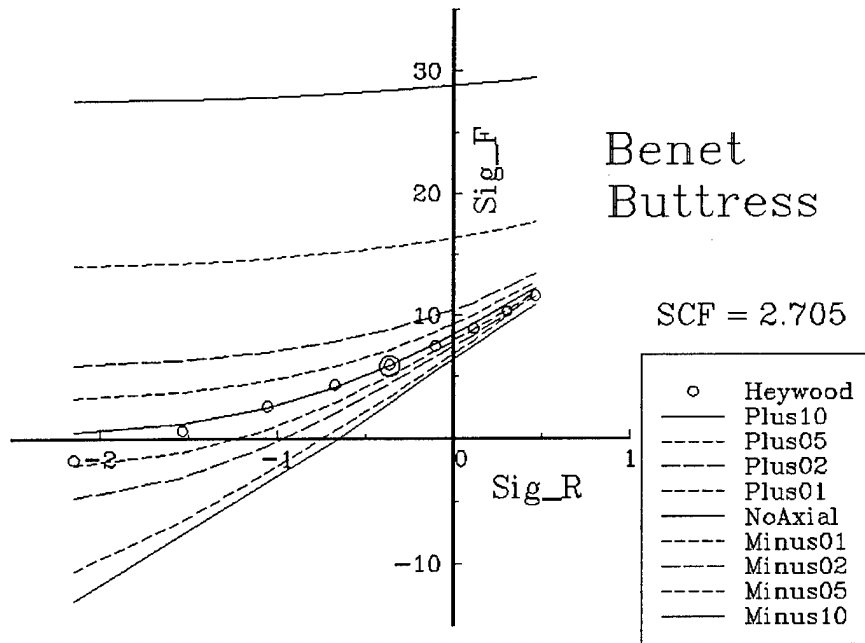

Figure 4. Characteristic plot for the 20-degree flank angle Benet buttress thread.

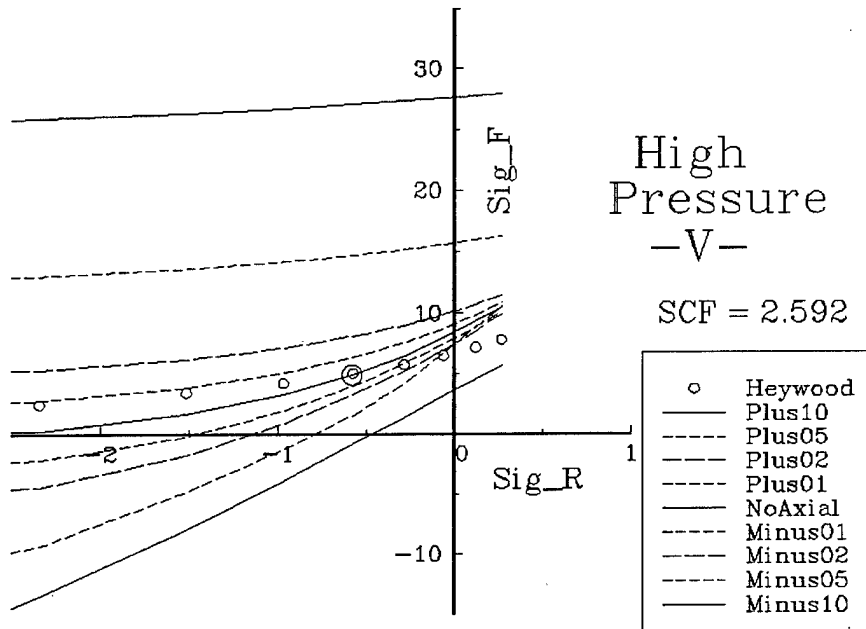

Figure 5. Characteristic plot for the 30-degree flank angle high pressure "V."

## DISCUSSION

All four thread forms in this report are intended to be high-strength threads for critical, heavily loaded connections. All of the threads are about the same height and all have generous fillet radii and similar values for the average bearing stress. They also are part of a system that uses the same thread shape for both internal and external thread forms, and the shapes have a built-in clearance on the unloaded rear flank. Because of these facts, they all have similar axial SCFs and would produce similar performance in cases where the axial stress concentration dominates the thread root stress picture. This effect has been shown in the three-dimensional photoelastic study by this author (ref 8). The highest recorded stress in that experiment was in an unloaded partial thread at the critical point in the connection. But this is not always the case, and stress from the load on the thread is of equal importance in selecting a thread form.

The stress from applied thread loads does vary significantly in these four threads, as shown in Table 1, and this variation can be correlated with the primary flank angle. Larger flank angles produce lower fillet stresses. The threads with a large flank angle also have a lower sensitivity to variation in the coefficient of friction and smaller sensitivity in radial stress with a variation in the coefficient of friction. To round out the list of improvements that can be gained by a high flank angle, the 30-degree "V" tends to benefit more from the addition of a compressive axial stress. This is shown by the larger spacing in the individual curves of the characteristic family. However, these improvements do not come without some penalty in the form of a larger radial stress. This does not seem to be a serious problem except in cases where either component is thin and has a low radial stiffness.

In this analysis, the coefficient of friction has been varied from 0.0 to 1.0 with the friction vector pointed in the negative and positive directions. In a specific application, the direction of the friction vector is dependent on the deformation state of the specific joint and can only be determined by an analysis of the individual structural system. The magnitude of the friction is controlled by the materials, surface conditions, and the past history of the specific structure. In normal engineering applications, the coefficient should be small and will rarely exceed 0.5, but the large range demonstrates the consistency of the friction effects. Again, the slope of the curves is a measure of the sensitivity of stress to changes in friction and a small slope is desirable to reduce variability in the fatigue life.

This work should tend to reinforce the notion that the elastic stress range in the fillet of any individual thread tooth is a complex function of three factors that combine in a nonlinear superposition process. The stress concentration and thread load stresses are of about the same importance and no general conclusions about thread fillet stresses are possible without reference to a specific threaded connection. The friction coefficient effects are a modifier on the thread load stress and should be small in a well lubricated joint. However, this may not be the case, and friction can play an important role in thread fillet stress.

## CONCLUSION

This report is an attempt to demonstrate that the stress in a thread fillet is the result of three primary effects:

- The load being carried by the individual thread tooth
- The stress concentration of the thread from the basic stress field
- Friction conditions on the thread from the component deformations

These three factors do not superimpose in a simple way, and the detailed analysis of a threaded connection is required for most critical connections. Further, the fillet stress is a strong function of primary flank angle and the SCF is a function of the root radius. However, practical high performance thread shapes will have similar root radii and similar stress concentrations. In cases where the general stresses are large and tensile, the difference in performance may be small. In other cases, performance will then be dominated by fillet stress and friction. Friction is generally an uncontrolled factor that will tend to produce some scatter in a fatigue test.

## REFERENCES

1. Weigle, R.E., Lasselle, R.R., and Purtell, J.P., "Experimental Investigation of the Fatigue Behavior of Thread-Type Projections," *Experimental Mechanics*, May 1963.
2. Weigle, R.E., and Lasselle, R.R., "Experimental Techniques for Predicting Fatigue Failure of Cannon-Breech Mechanisms," *Experimental Mechanics*, February 1965.
3. Heywood, R.B., *Designing by Photoelasticity*, Chapman & Hall, Ltd., London, 1952, pp. 205-215.
4. Neuber, H., *Theory of Notch Stresses*, English Translation by F.A. Ravin and J.W. Edwards, David Taylor Model Basin, U.S. Navy, Ann Arbor, 1946
5. *ABAQUS User's Manual*, Version 5.5-1, Hibbitt, Karlsson, and Sorensen, Inc. (HKS), 1000 Main Street, Pawtucket, RI, 1995.
6. O'Hara, G.P., "Stress Concentrations in Screw Threads," Technical Report ARLCB-TR-80010, Benet Laboratories, Watervliet, NY, April 1980; Also (without Appendix) *Eighth NASTRAN Users' Colloquium*, Goddard Space Flight Center, NASA Conference Publication 2131, October 1979, pp. 65-77.
7. O'Hara, G.P., "Elastic-Plastic Comparison of Three Thread Forms," *Proceedings of the Eighth U.S. Army Symposium on Gun Dynamics*, (G. Albert Pflegl, Ed.), ARCCB-SP-96032, Benet Laboratories, Watervliet, NY, November 1996, p. 18-1.
8. O'Hara, G.P., "Photoelastic Stress Analysis of a High Pressure Breech," Technical Report WVT-7057, Benet Laboratories, Watervliet, NY, December 1970.



## APPENDIX A

The following appendix will provide added information on the four threads in this report and add data for four more thread forms that have been calculated. The information includes basic geometry data, strength-of-materials stress parameters, and a full combined characteristic plot, using a standard plotting format. This will allow the reader to do a more extensive evaluation of the elastic properties of the eight threads. The threads have a wide range of geometry parameters and have been selected from over 60 geometries that have been taken from many sources.

Historical data concerning the design of most of the threads have not been recovered, with the exception of some general information about the original application. There is also a short descriptive paragraph stating the source of the particular thread and a listing of the basic geometry parameters and strength-of-materials stress parameters.

The geometry parameters are shown in Figure 1a and defined below:

Alpha ( $\alpha$ )	=	Primary (loaded) flank angle
Beta ( $\beta$ )	=	Secondary (unloaded) flank angle
Root Radius (RR)	=	Thread fillet radius
Tip Radius (TR)	=	Radius at the tip of the contact surface
Addendum (AA)	=	Height above the pitch line
Dedendum (DD)	=	Height below the pitch line
Total Height (HT)	=	Total of AD and DD
Bearing Height (BH)	=	Projected height of the contact surface
Shear Length (SL)	=	Thread width at the shear-off plane
Square Off (SO)	=	Construction width across the fillet

Heywood and strength-of-materials parameters for a unit shear transfer stress are:

- Fillet stress is the average of seven calculations of Heywood's equation.
- Bearing stress is the simple average bearing stress.
- Shear stress is the simple average shear stress on the failure plane.
- Tensile SCF is the stress concentration factor from the work of Neuber.
- Radial stress is the simple wedge angle stress at zero friction.
- Slope is the average slope of the characteristic curve calculated from the work of Heywood.

# Thread Geometry Parameters

Figure 1a.

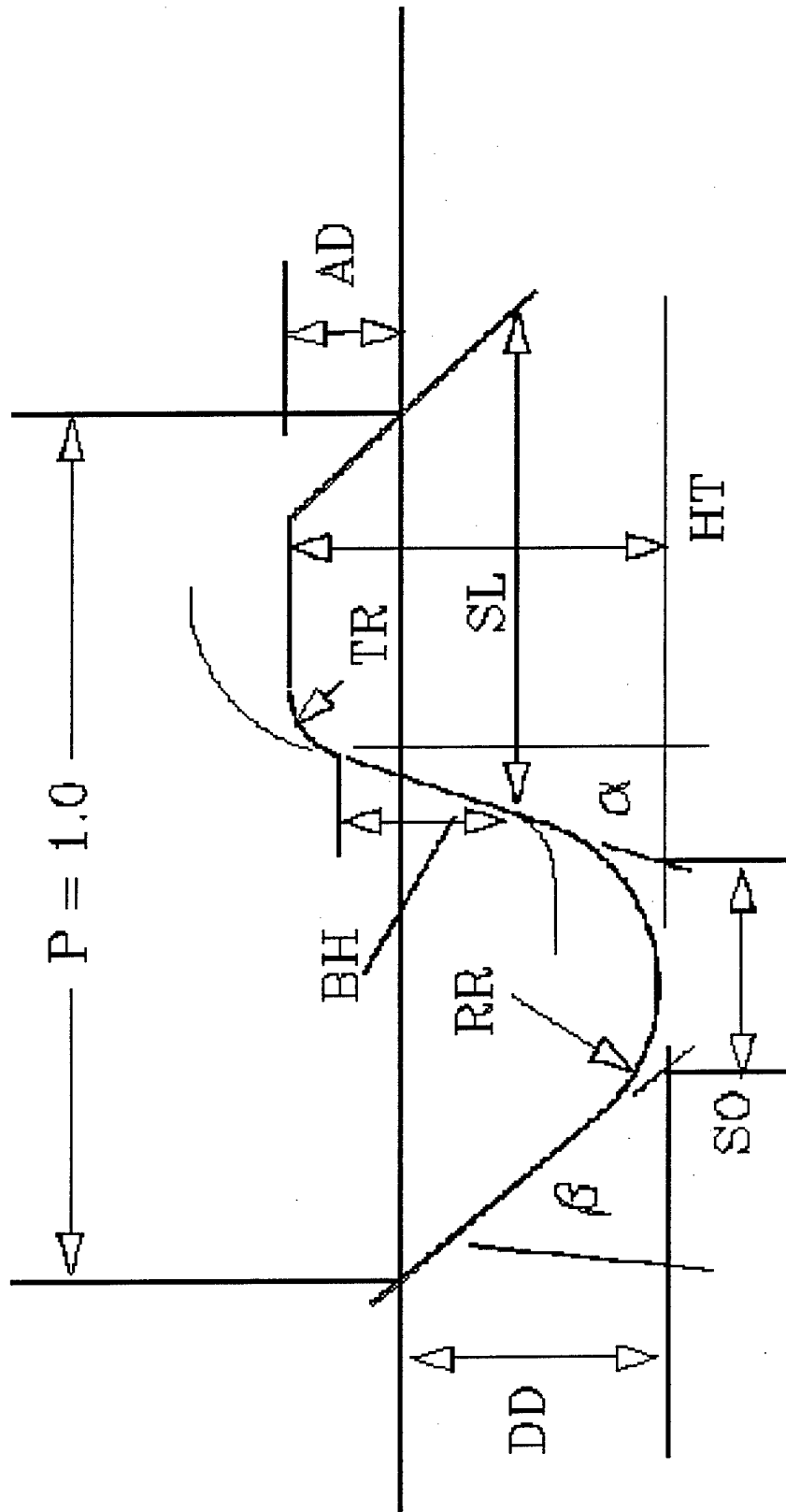

## FRG BUTTRESS

This thread is used on the 120-mm M256 gun designed in the Federal Republic of Germany. It is shown on U.S. Army Drawing No. F-12528311-1984, with an actual pitch of 10 mm.

Geometry Parameters for Pitch = 1.0000:

Alpha	=	3.0	Beta	=	45.0
Root Radius	=	0.1250	Tip Radius	=	0.04
Addendum	=	0.2300	Dedendum	=	0.27
Total Height	=	0.5000	Bearing Height	=	0.3435
Shear Length	=	0.6595	Square Off	=	0.2158

Heywood and Strength-of-Materials Parameters:

Fillet Stress	=	9.886	Bearing Stress	=	2.910
Shear Stress	=	1.516	Tensile SCF	=	2.377
Radial Stress	=	0.0524	Slope	=	10.38

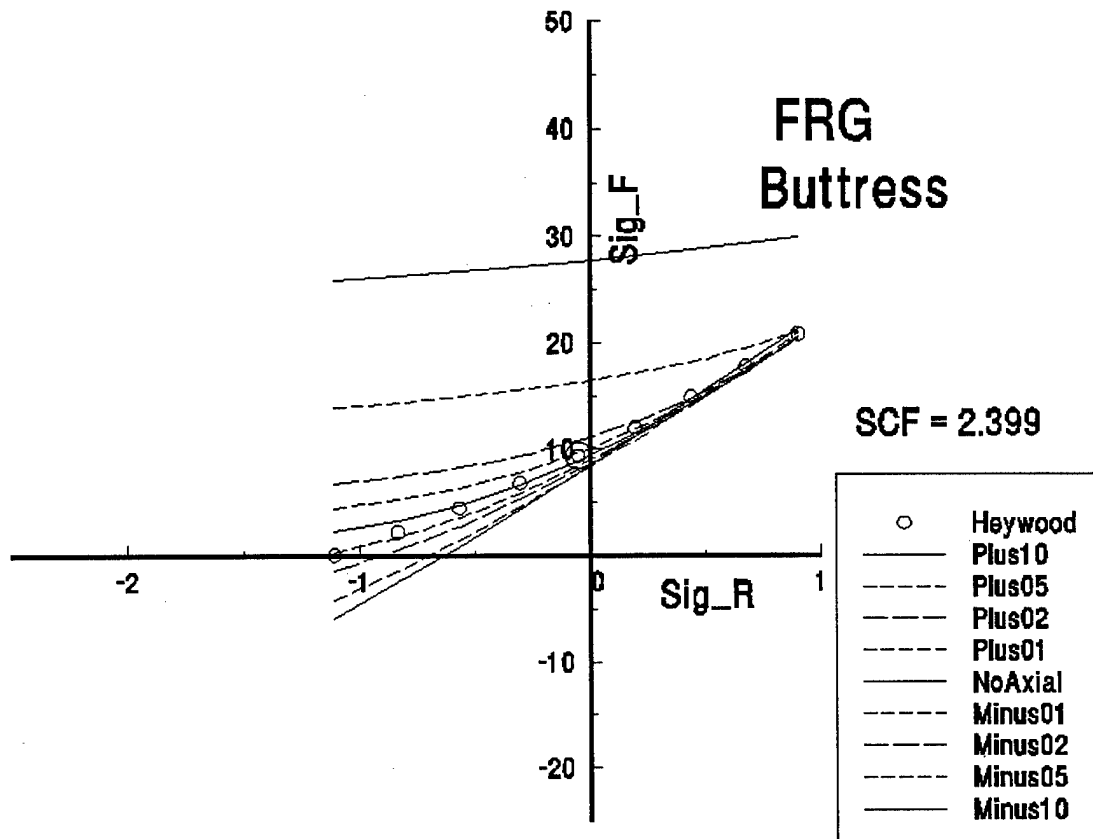

Figure 2a. Characteristic plot for FRG buttress thread.

## BRITISH STANDARD BUTTRESS

This thread is similar to the one used on the 105-mm M68 gun designed in England in the late 1950s. It seems to have been developed by R.B. Heywood or at least was influenced by him. On the M68, it has an actual pitch of 0.33333 inch.

Geometry Parameters for Pitch = 1.0000:

Alpha	=	7.0	Beta	=	45.0
Root Radius	=	0.12055	Tip Radius	=	0.000
Addendum	=	0.2000	Dedendum	=	0.3059
Total Height	=	0.50586	Bearing Height	=	0.4000
Shear Length	=	0.7245	Square Off	=	0.1566

Heywood and Strength-of-Materials Parameters:

Fillet Stress	=	8.646	Bearing Stress	=	2.500
Shear Stress	=	1.380	Tensile SCF	=	2.608
Radial Stress	=	0.123	Slope	=	8.86

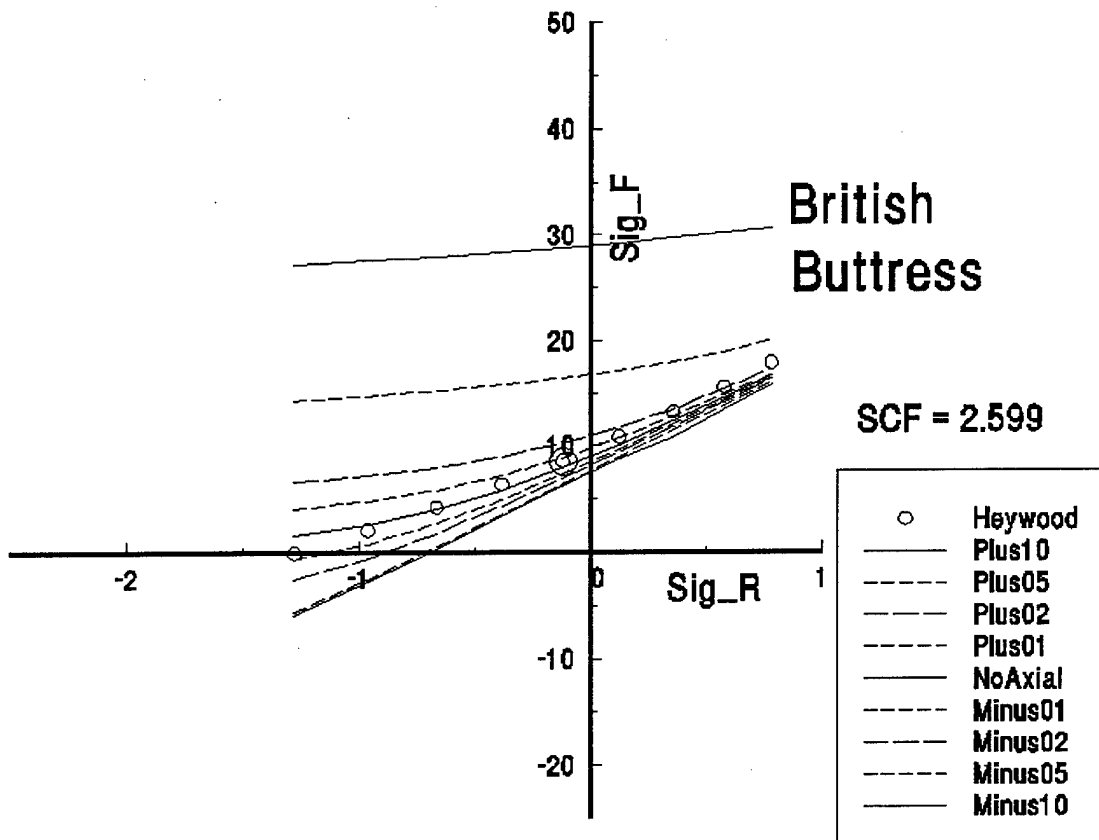

Figure 3a. Characteristic plot for British standard buttress thread.

## STUB ACME

This thread is used as the muzzle brake attachment for the 155-mm M185 howitzer and is shown on U.S. Army Drawing No. 11578384-1970. Like all ACME threads, in actual use it has definite fillet radii and good tip radius. On the M185, it has an actual pitch of 0.5000 inch. The standards show an ACME, Stub ACME, and two Modified Stub ACMEs.

Geometry Parameters for Pitch = 1.0000:

Alpha	=	14.5	Beta	=	14.5
Root Radius	=	0.0300	Tip Radius	=	0.0400
Addendum	=	0.1400	Dedendum	=	0.1600
Total Height	=	0.3000	Bearing Height	=	0.2200
Shear Length	=	0.5521	Square Off	=	0.4220

Heywood and Strength-of-Materials Parameters:

Fillet Stress	=	10.975	Bearing Stress	=	4.545
Shear Stress	=	1.811	Tensile SCF	=	2.998
Radial Stress	=	0.259	Slope	=	10.18

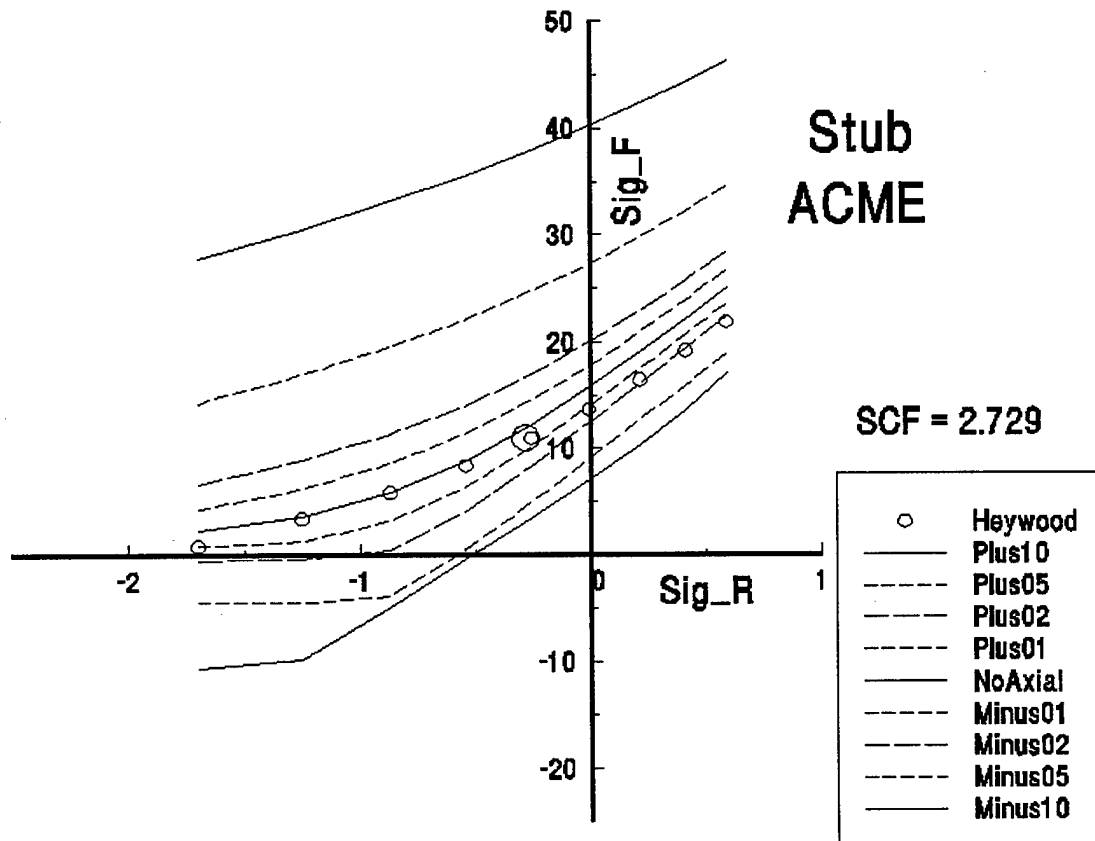

Figure 4a. Characteristic plot for Stub ACME thread.

## MODIFIED "V"

This thread is used on the 175-mm gun/8-inch howitzer breech, as the connection between the ring and bushing. Its origins are unknown, but the style is one commonly used on guns at the end of the nineteenth and into the early twentieth century. This is interesting, but there is only one known application shown on U.S. Army Drawing No. WTV F-11579239.

Geometry Parameters for Pitch = 1.0000:

Alpha	=	15.00	Beta	=	37.15
Root Radius	=	0.136	Tip Radius	=	0.0000
Addendum	=	0.2255	Dedendum	=	0.3263
Total Height	=	0.35519	Bearing Height	=	0.4511
Shear Length	=	0.7247	Square Off	=	0.1719

Heywood and Strength-of-Materials Parameters:

Fillet Stress	=	6.898	Bearing Stress	=	2.217
Shear Stress	=	1.380	Tensile SCF	=	2.407
Radial Stress	=	0.268	Slope	=	3.56

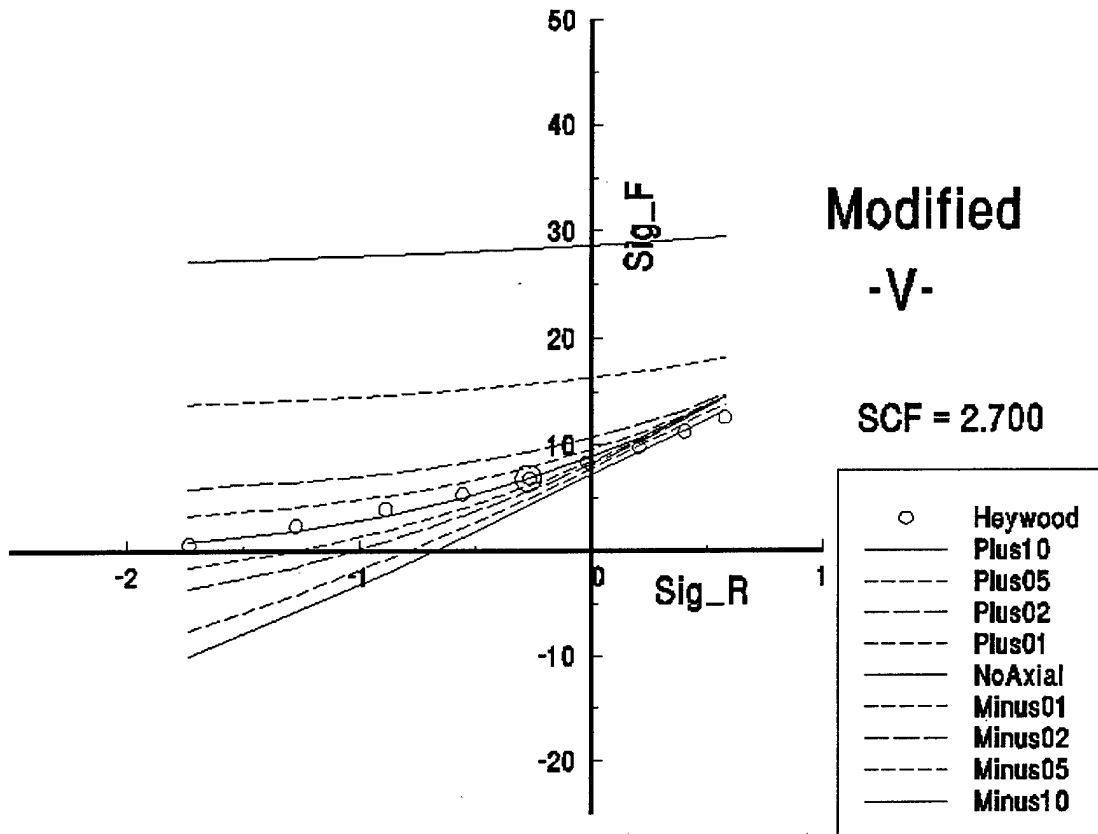

Figure 5a. Characteristic plot for modified "V" thread.

## BENET BUTTRESS

This thread is the result of a fatigue problem with the original 155-mm T255 howitzer, which later became the M126, then the M185, and finally the M284 howitzer. The thread was developed at Watervliet Arsenal in 1962 and has been used on all U.S. designed cannons since that date. The pitch is usually 0.375 inch, but other sizes have been used.

Geometry Parameters for Pitch = 1.0000:

Alpha	=	20.00	Beta	=	45.0
Root Radius	=	0.13333	Tip Radius	=	0.0480
Addendum	=	0.2013	Dedendum	=	0.2774
Total Height	=	0.4787	Bearing Height	=	0.3394
Shear Length	=	0.7311	Square Off	=	0.1492

Heywood and Strength-of-Materials Parameters:

Fillet Stress	=	5.941	Bearing Stress	=	2.946
Shear Stress	=	1.421	Tensile SCF	=	2.538
Radial Stress	=	0.364	Slope	=	5.71

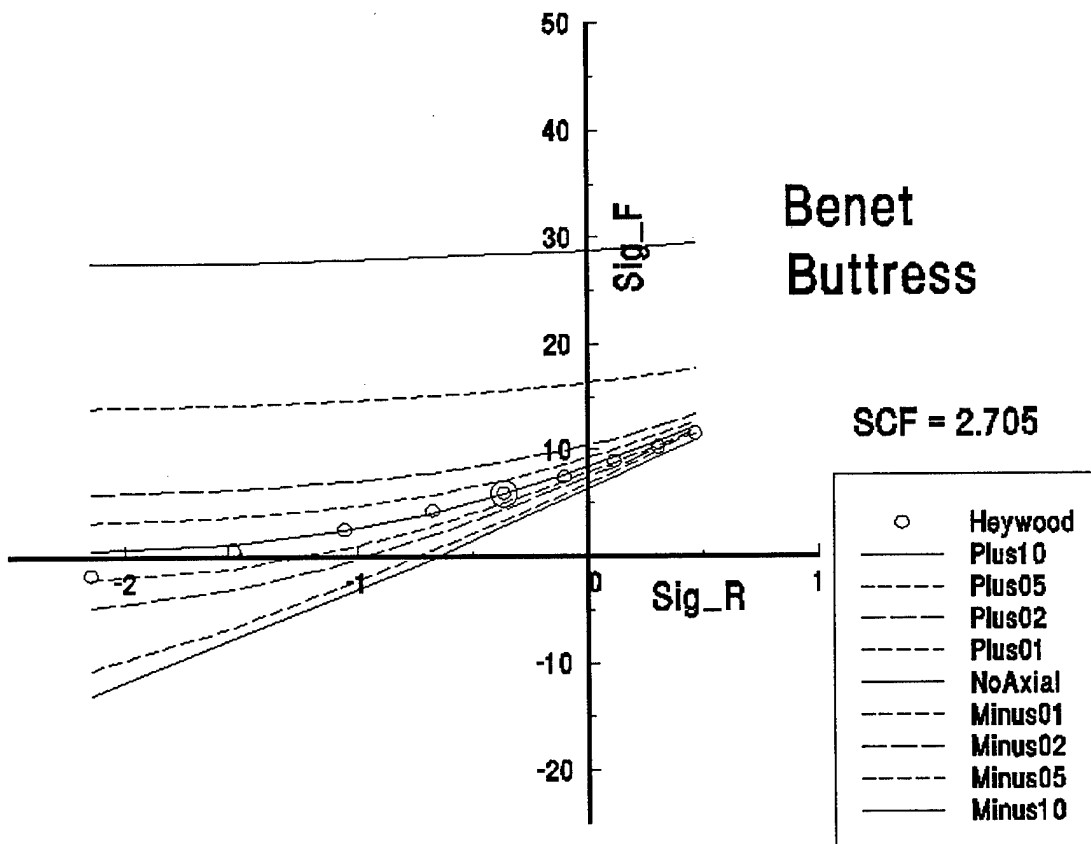

Figure 6a. Characteristic plot for Benet buttress thread.

## HIGH PRESSURE "V"

This thread is intended to be used in applications where good fatigue life of the connection is critical and the joint requires a balanced thread with identical internal and external forms. The same pitch/diameter relations given in normal "V" thread standards also apply here. This thread has been given a generous root radius from improved performance.

Geometry Parameters for Pitch = 1.0000:

Alpha	=	30.00	Beta	=	30.0
Root Radius	=	0.15011	Tip Radius	=	0.0000
Addendum	=	0.2150	Dedendum	=	0.3002
Total Height	=	0.5152	Bearing Height	=	0.4300
Shear Length	=	0.7283	Square Off	=	0.1733

Heywood and Strength-of-Materials Parameters:

Fillet Stress	=	5.036	Bearing Stress	=	2.326
Shear Stress	=	1.373	Tensile SCF	=	2.364
Radial Stress	=	0.577	Slope	=	2.47

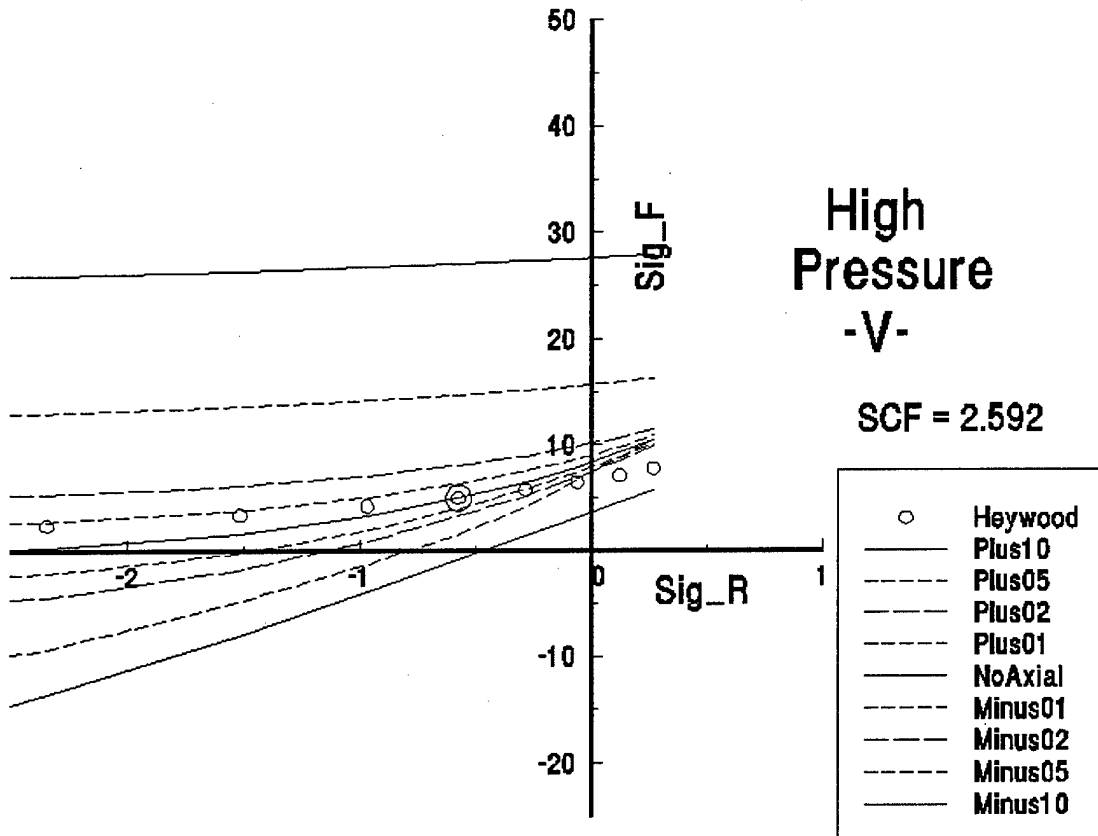

Figure 7a. Characteristic plot for high pressure "V" thread.

## EXTERNAL "V" (UNR)

This thread is taken from the thread standard (UNR) for external bolting threads with a controlled root radius. It has the usual high profile with a narrow top and geometry representing minimum root radius and minimum total height permitted in the specification. It should have a continuous smooth curve, but has been slightly idealized with a short flat in the fillet. This produces a wide square-off dimension.

Geometry Parameters for Pitch = 1.0000:

Alpha	=	30.00	Beta	=	30.0
Root Radius	=	0.1080	Tip Radius	=	0.0000
Addendum	=	0.3248	Dedendum	=	0.2706
Total Height	=	0.5954	Bearing Height	=	0.5414
Shear Length	=	0.7502	Square Off	=	0.1875

Heywood and Strength-of-Materials Parameters:

Fillet Stress	=	5.036	Bearing Stress	=	2.326
Shear Stress	=	1.373	Tensile SCF	=	2.364
Radial Stress	=	0.577	Slope	=	2.50

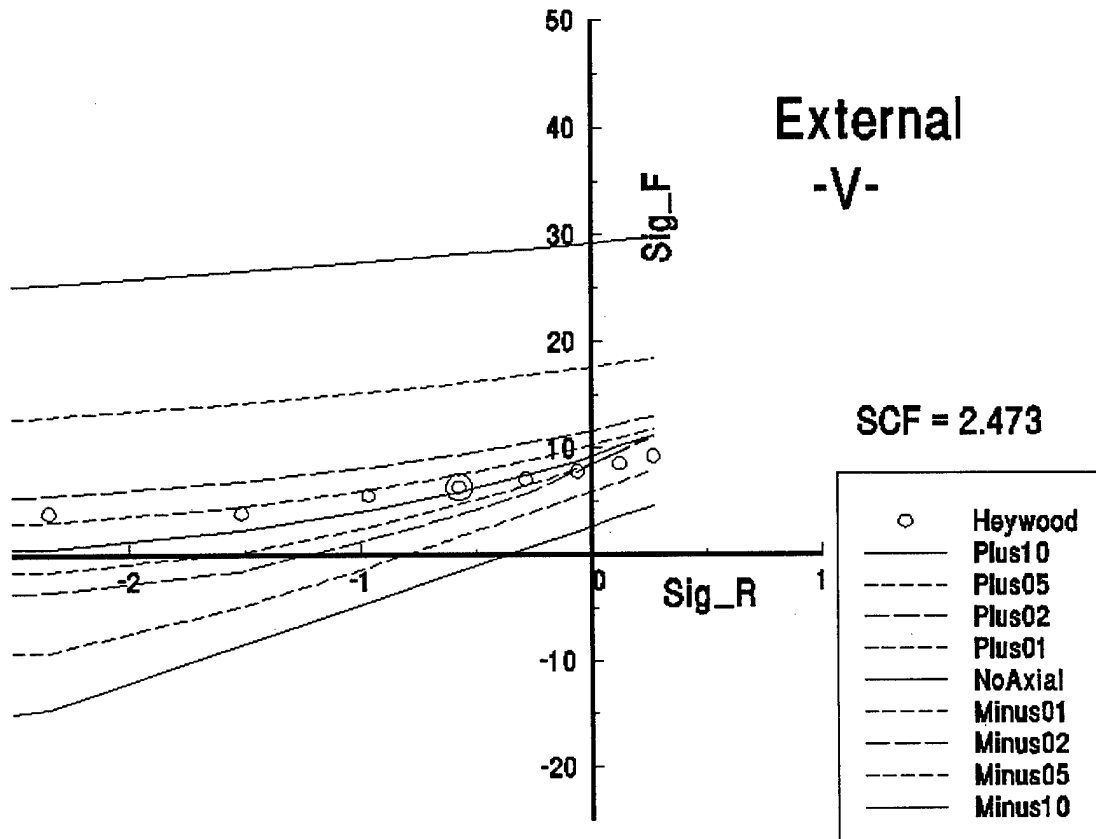

Figure 8a. Characteristic plot for external "V" (UNR) thread.

## INTERNAL "V" (UN)

This thread is taken directly from the thread standard (UN) for a standard internal thread. It has the usual small root radius with a wide top to avoid the larger fillet radius of the external side. The normal assumption is that the outer component is predominately compressive and can tolerate the higher stress concentration of the smaller root radius.

Geometry Parameters for Pitch = 1.0000:

Alpha	=	30.00	Beta	=	30.0
Root Radius	=	0.07217	Tip Radius	=	0.0000
Addendum	=	0.2165	Dedendum	=	0.3608
Total Height	=	0.5773	Bearing Height	=	0.5413
Shear Length	=	0.8750	Square Off	=	0.0833

Heywood and Strength-of-Materials Parameters:

Fillet Stress	=	6.302	Bearing Stress	=	1.847
Shear Stress	=	1.143	Tensile SCF	=	3.137
Radial Stress	=	0.577	Slope	=	3.008

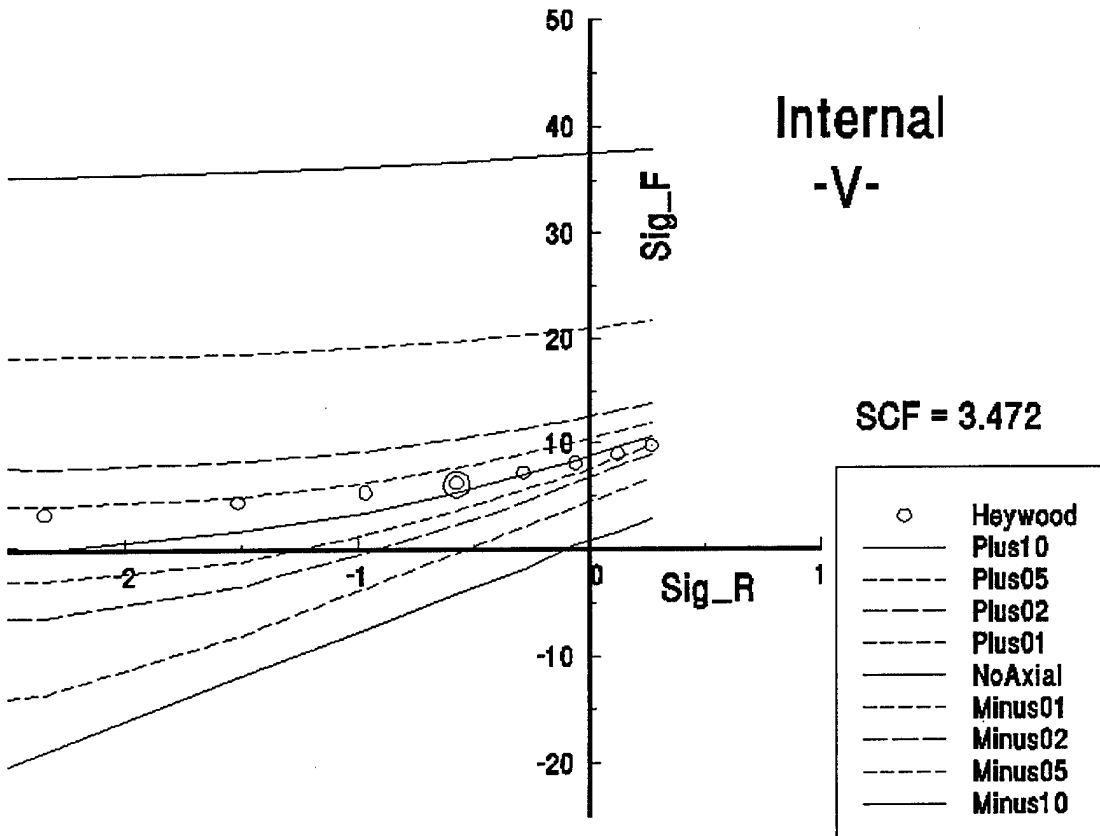

Figure 9a. Characteristic plot for internal "V" (UN) thread.

---

TECHNICAL REPORT INTERNAL DISTRIBUTION LIST

	<u>NO. OF COPIES</u>
CHIEF, DEVELOPMENT ENGINEERING DIVISION	
ATTN: AMSTA-AR-CCB-DA	1
-DB	1
-DC	1
-DD	1
-DE	1
 CHIEF, ENGINEERING DIVISION	
ATTN: AMSTA-AR-CCB-E	1
-EA	1
-EB	1
-EC	1
 CHIEF, TECHNOLOGY DIVISION	
ATTN: AMSTA-AR-CCB-T	2
-TA	1
-TB	1
-TC	1
 TECHNICAL LIBRARY	
ATTN: AMSTA-AR-CCB-O	5
 TECHNICAL PUBLICATIONS & EDITING SECTION	
ATTN: AMSTA-AR-CCB-O	3
 OPERATIONS DIRECTORATE	
ATTN: SLOWV-ODP-P	1
 DIRECTOR, PROCUREMENT & CONTRACTING DIRECTORATE	
ATTN: SLOWV-PP	1
 DIRECTOR, PRODUCT ASSURANCE & TEST DIRECTORATE	
ATTN: SLOWV-QA	1

NOTE: PLEASE NOTIFY DIRECTOR, BENÉT LABORATORIES, ATTN: AMSTA-AR-CCB-O OF ADDRESS CHANGES.

---

TECHNICAL REPORT EXTERNAL DISTRIBUTION LIST

	<u>NO. OF COPIES</u>		<u>NO. OF COPIES</u>
ASST SEC OF THE ARMY RESEARCH AND DEVELOPMENT ATTN: DEPT FOR SCI AND TECH THE PENTAGON WASHINGTON, D.C. 20310-0103	1	COMMANDER ROCK ISLAND ARSENAL ATTN: SMCRI-SEM ROCK ISLAND, IL 61299-5001	1
DEFENSE TECHNICAL INFO CENTER ATTN: DTIC-OCP (ACQUISITIONS) 8725 JOHN J. KINGMAN ROAD STE 0944 FT. BELVOIR, VA 22060-6218	2	MIAC/CINDAS PURDUE UNIVERSITY 2595 YEAGER ROAD WEST LAFAYETTE, IN 47906-1398	1
COMMANDER U.S. ARMY ARDEC ATTN: AMSTA-AR-AEE, BLDG. 3022 AMSTA-AR-AES, BLDG. 321 AMSTA-AR-AET-O, BLDG. 183 AMSTA-AR-FSA, BLDG. 354 AMSTA-AR-FSM-E AMSTA-AR-FSS-D, BLDG. 94 AMSTA-AR-IMC, BLDG. 59 PICATINNY ARSENAL, NJ 07806-5000	1 1 1 1 1 1 2	COMMANDER U.S. ARMY TANK-AUTMV R&D COMMAND ATTN: AMSTA-DDL (TECH LIBRARY) WARREN, MI 48397-5000	1
DIRECTOR U.S. ARMY RESEARCH LABORATORY ATTN: AMSRL-DD-T, BLDG. 305 ABERDEEN PROVING GROUND, MD 21005-5066	1	COMMANDER U.S. MILITARY ACADEMY ATTN: DEPARTMENT OF MECHANICS WEST POINT, NY 10966-1792	1
DIRECTOR U.S. ARMY RESEARCH LABORATORY ATTN: AMSRL-WT-PD (DR. B. BURNS) ABERDEEN PROVING GROUND, MD 21005-5066	1	U.S. ARMY MISSILE COMMAND REDSTONE SCIENTIFIC INFO CENTER ATTN: AMSMI-RD-CS-R/DOCUMENTS BLDG. 4484 REDSTONE ARSENAL, AL 35898-5241	2
DIRECTOR U.S. MATERIEL SYSTEMS ANALYSIS ACTV ATTN: AMXSY-MP ABERDEEN PROVING GROUND, MD 21005-5071	1	COMMANDER U.S. ARMY FOREIGN SCI & TECH CENTER ATTN: DRXST-SD 220 7TH STREET, N.E. CHARLOTTESVILLE, VA 22901	1
		COMMANDER U.S. ARMY LABCOM, ISA ATTN: SLCIS-IM-TL 2800 POWER MILL ROAD ADELPHI, MD 20783-1145	1

NOTE: PLEASE NOTIFY COMMANDER, ARMAMENT RESEARCH, DEVELOPMENT, AND ENGINEERING CENTER,  
BENÉT LABORATORIES, CCAC, U.S. ARMY TANK-AUTOMOTIVE AND ARMAMENTS COMMAND,  
AMSTA-AR-CCB-O, WATERVLIET, NY 12189-4050 OF ADDRESS CHANGES.

TECHNICAL REPORT EXTERNAL DISTRIBUTION LIST (CONT'D)

	<u>NO. OF COPIES</u>		<u>NO. OF COPIES</u>
COMMANDER U.S. ARMY RESEARCH OFFICE ATTN: CHIEF, IPO P.O. BOX 12211 RESEARCH TRIANGLE PARK, NC 27709-2211	1	WRIGHT LABORATORY ARMAMENT DIRECTORATE ATTN: WL/MNM EGLIN AFB, FL 32542-6810	1
DIRECTOR U.S. NAVAL RESEARCH LABORATORY ATTN: MATERIALS SCI & TECH DIV WASHINGTON, D.C. 20375	1	WRIGHT LABORATORY ARMAMENT DIRECTORATE ATTN: WL/MNMF EGLIN AFB, FL 32542-6810	1

NOTE: PLEASE NOTIFY COMMANDER, ARMAMENT RESEARCH, DEVELOPMENT, AND ENGINEERING CENTER,  
 BENÉT LABORATORIES, CCAC, U.S. ARMY TANK-AUTOMOTIVE AND ARMAMENTS COMMAND,  
 AMSTA-AR-CCB-O, WATERVLIET, NY 12189-4050 OF ADDRESS CHANGES.

---