



**SDIO  
ELECTRONIC DOCUMENT  
MANAGEMENT PROTOTYPE  
REQUIREMENTS ANALYSIS**

**"AS-IS" NODE TREE  
AND  
ACTIVITY MODELS**

**DISTRIBUTION STATEMENT A**  
Approved for public release;  
Distribution Unlimited

**DTIC QUANTITY INDICATED**  
PLEASE RETURN TO:

MAY 26, 1992

**BMD TECHNICAL INFORMATION CENTER  
BALLISTIC MISSILE DEFENSE ORGANIZATION  
7100 DEFENSE PENTAGON  
WASHINGTON D.C. 20301-7100**

19980309 149

U4547

III. Document Management "As Is" Models

A. SDI Technical Information Center (TIC)

The SDI TIC coordinates the collection and dissemination of classified and unclassified materials to current and potential contractors, SDIO staff members, and other government personnel participating in the SDI program. The TIC's main activity is to provide information both proactively and by request to and about SDIO and SDI-related activities. The TIC Node Tree ("As Is" Environment) depicts these activities.

This analysis presents a total enterprise perspective of the TIC. This was the initial understanding of the study's scope. That scope was refined at the April 7, 1992 meeting to focus on document management functions. Since the total environment of the TIC had been modeled already, it was decided to retain these models for the TIC.

As a result, the TIC administrative functions are part of the "As Is" Node Tree. The circles are black, indicating these functions are outside the scope of this analysis.

PLEASE RETURN TO:  
BMD TECHNICAL INFORMATION CENTER  
BALLISTIC MISSILE DEFENSE ORGANIZATION  
3100 BELT ROAD  
WASHINGTON D.C. 20315-1100

Accession Number: 4547

Publication Date: May 26, 1992

Title: SDIO Electronic Document Management Prototype Requirements Analysis: "As-Is" Node Tree and Activity Models

Corporate Author Or Publisher: SDIO, The Pentagon, Washington, DC 20301

Descriptors, Keywords: SDIO Electronic Document Management Prototype Requirement Analysis As-Is Data Entity List

Pages: 00050

Cataloged Date: Jun 23, 1993

Document Type: HC

Number of Copies In Library: 000001

Record ID: 27190

# TIC NODE TREE (AS-IS ENVIRONMENT)

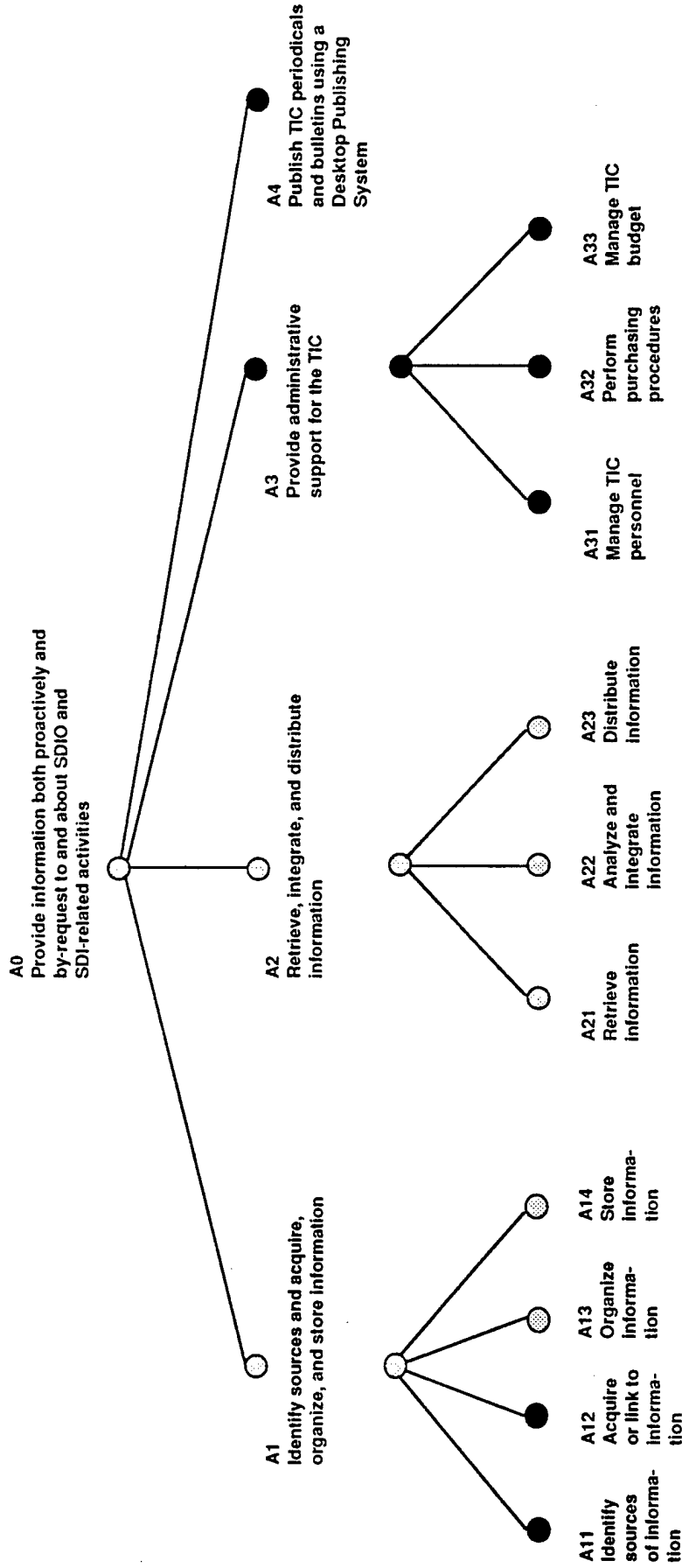

● = POTENTIALLY WITHIN PROGRAM SCOPE

IDEF

The "As Is" Activity Models are a graphic and textual presentation of the current environment. The purpose of this exercise is to present a clear picture of each organization's or function's current activity flow. This is broken down (or decomposed) to a level of detail necessary to provide a clear picture of the document management activities.

Each model is preceded by a discussion of its components.

#### TIC "AS IS" ACTIVITY MODEL

- A0 - This is the highest level of the TIC "As Is" Activity Model. An overall picture of the TIC's activities is described.

DEPICTION: AS-IS	AUTHOR: Ed Steger PROJECT: Electronic Document Management	DATE: 5/4/92 REV:	X WORKING FINAL	TECHNICAL INFORMATION CENTER POC: Mike Metrione Lucille Perodeau James Tildon Linda Burkhouse	CONTEXT: TOP
---------------------	--	----------------------	-----------------------	---	-----------------

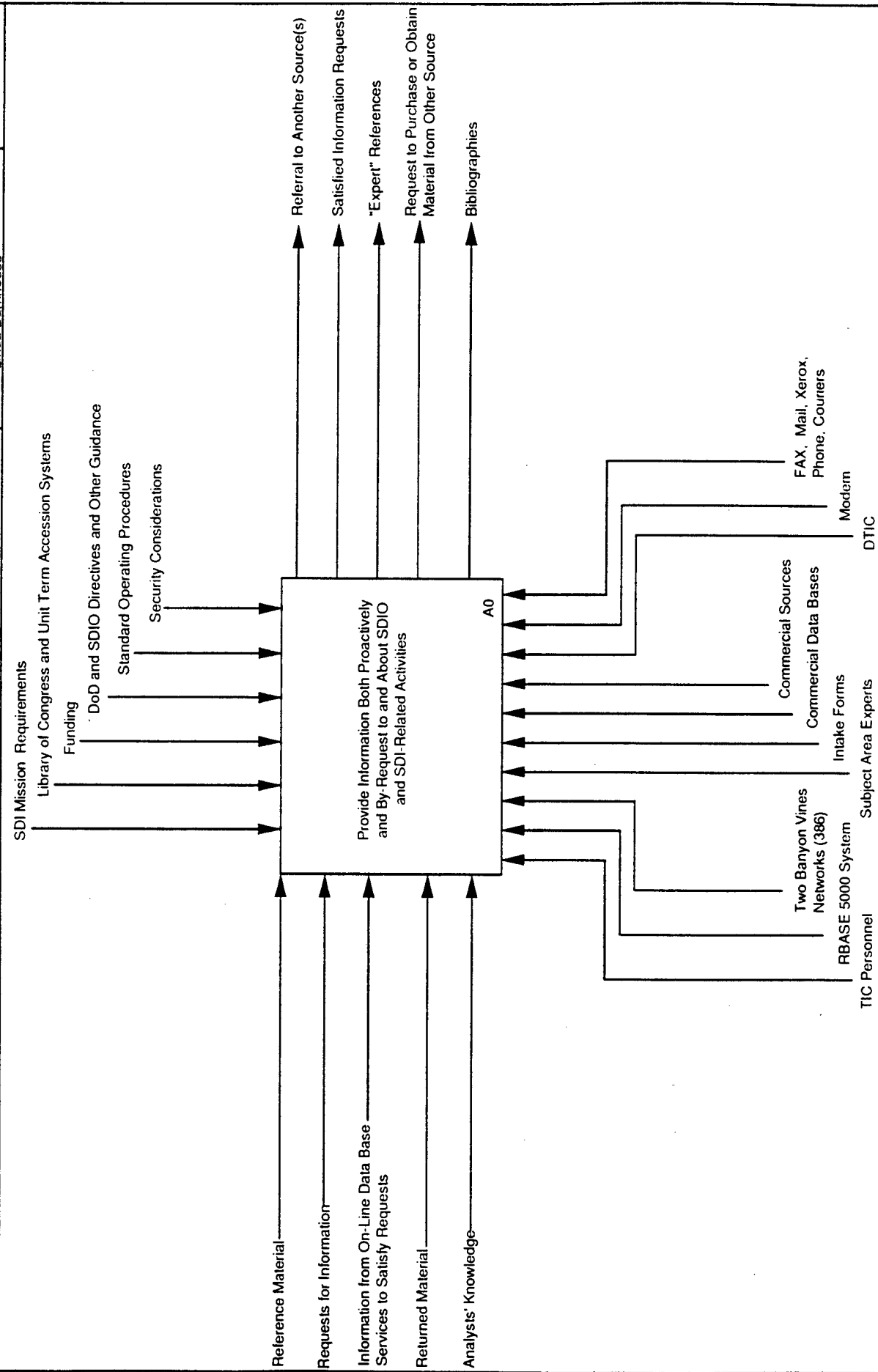

NODE: A-0	PERSPECTIVE: TIC	NUMBER:
-----------	------------------	---------

A0 - PROVIDE INFORMATION BOTH PROACTIVELY AND BY REQUEST TO AND ABOUT SDIO AND SDI-RELATED ACTIVITIES

A1 - IDENTIFY SOURCES, AND ACQUIRE, ORGANIZE, AND STORE INFORMATION

This activity includes the process of identifying sources of information to keep the TIC up-to-date and of obtaining, organizing, and storing that information.

A2 - RETRIEVE, INTEGRATE, AND DISTRIBUTE INFORMATION

This activity includes the process of retrieving, integrating, and distributing information in order to respond to requests for that information, and to disseminate material that presents the information that is available.

A3 - PROVIDE ADMINISTRATIVE SUPPORT FOR THE TIC

This includes the administrative functions required for continued operation of the TIC.

DEPICTION: AS-IS	AUTHOR: Ed Steger	DATE: 5/4/92	WORKING X	TECHNICAL INFORMATION CENTER	CONTEXT: ■
	PROJECT: Electronic Document Management	REV:			

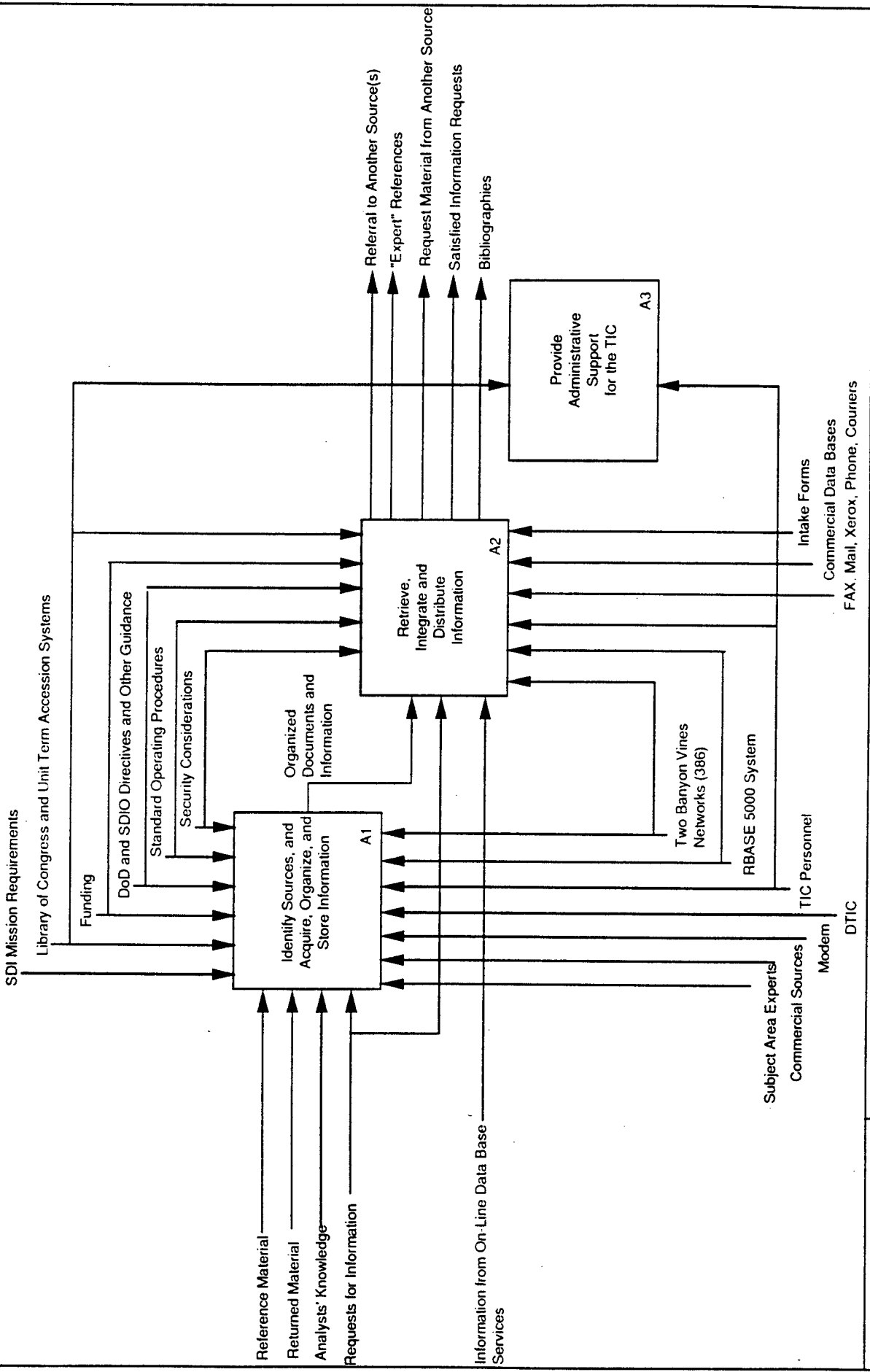

NODE: A0	TITLE: Provide Information Both Proactively and By-Request to and About SDIO and SDI-Related Activities	NUMBER:
----------	---	---------

A1 - IDENTIFY SOURCES, AND ACQUIRE, ORGANIZE, AND STORE INFORMATION

A11 - IDENTIFY SOURCES OF INFORMATION

This includes the receipt of requests and the analysts' professional knowledge that is used to identify sources of information.

A12 - ACQUIRE OR LINK TO INFORMATION

This includes the acquisition from a variety of sources of the information required to be responsive to requests that come into the TIC.

A13 - ORGANIZE INFORMATION

This includes the cataloging and data base activities involved in organizing the incoming information in such a way as to be able to access it quickly when necessary.

A14 - STORE INFORMATION

This includes the storage of information within the RBASE 5000 system. The storage is in the form of an electronic card catalog so that information retrieval will be an efficient process.

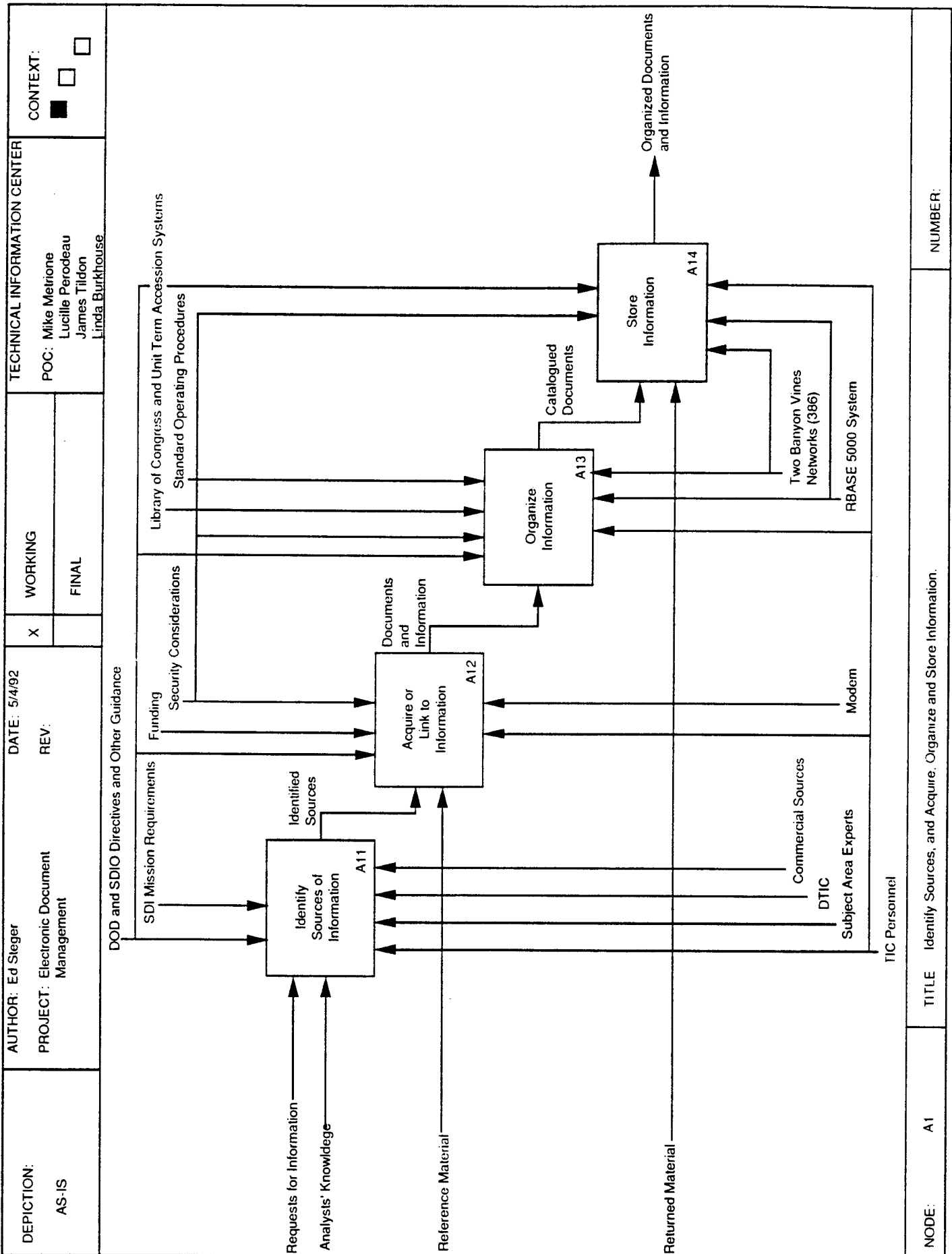

A2 - RETRIEVE, INTEGRATE, AND DISTRIBUTE INFORMATION

A21 - RETRIEVE INFORMATION

This includes the process involved to retrieve information in response to a requestor or from an on-line data base on the RBASE 5000 application. The request may be satisfied immediately or referred to another source.

A22 - ANALYZE AND INTEGRATE INFORMATION

This includes the assimilation of information from one or more sources to satisfy and information request.

A23 - DISTRIBUTE INFORMATION

This includes the distribution of information to serve a variety of purposes. It may fulfill an information request, provide insight to refer a requestor to another expert, or provide substance to produce periodic bibliographies.



B. Configuration Management

SDIO uses the Configuration Management process to control and maintain the integrity and accuracy of documents that are identified as configuration items. This is accomplished by the SDIO Configuration Management Office GE Personnel (SE&I), and procedures highlighted in the GPALS Configuration Control Board (GCCB) Procedures. Once configuration items are identified, they are subject to distribution and review by GCCB members. Changes to the document are made through Engineering Change Proposals approved by the GCCB and incorporated into a controlled version. This document becomes the controlled baseline.

The Configuration Management "As Is" Node Tree illustrates the overall Configuration Management process.

# CONFIGURATION MANAGEMENT NODE TREE (AS-IS ENVIRONMENT)

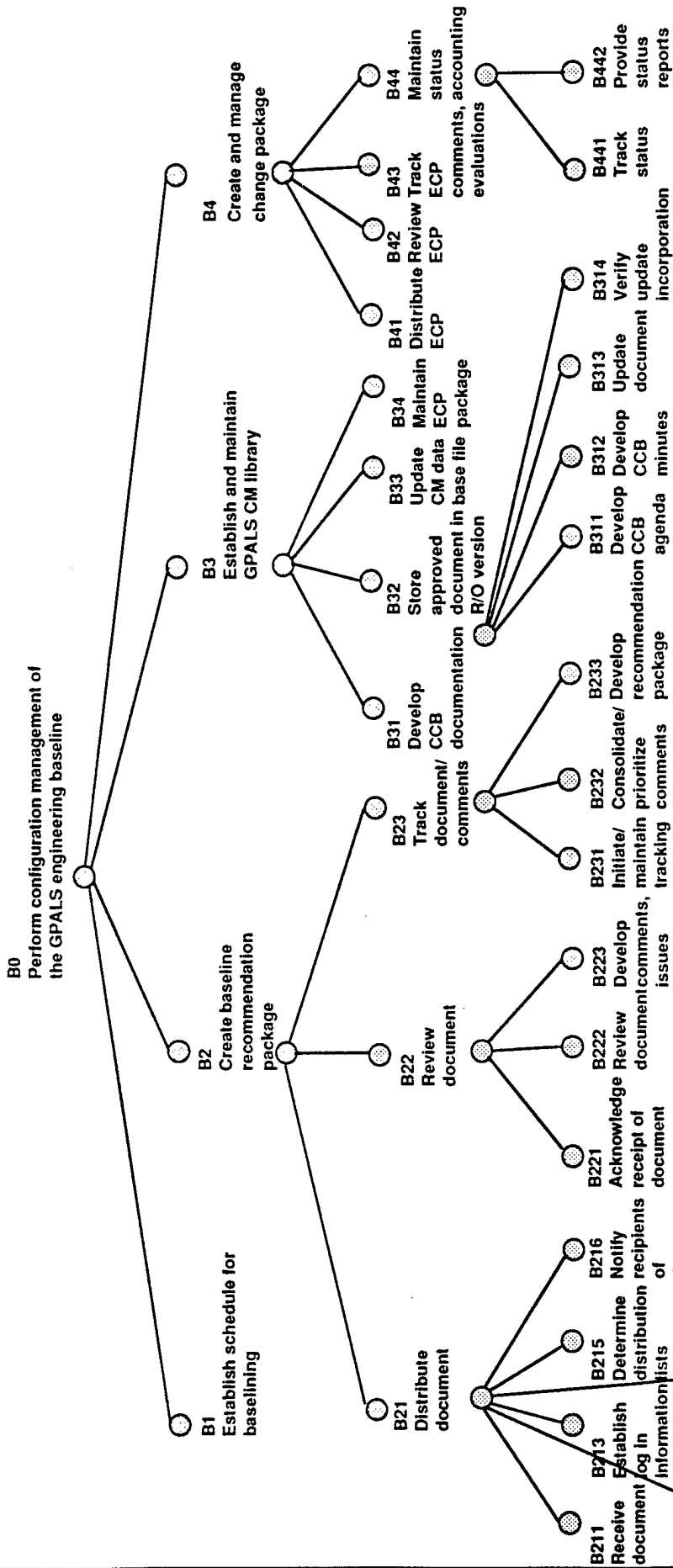

⊙ = POTENTIALLY WITHIN PROGRAM SCOPE

IDEF

## CONFIGURATION MANAGEMENT "AS IS" ACTIVITY MODEL

- B0 - This is the highest level of the Configuration Management "As Is" Activity Model. It presents an overall picture of configuration management activities within SDIO.

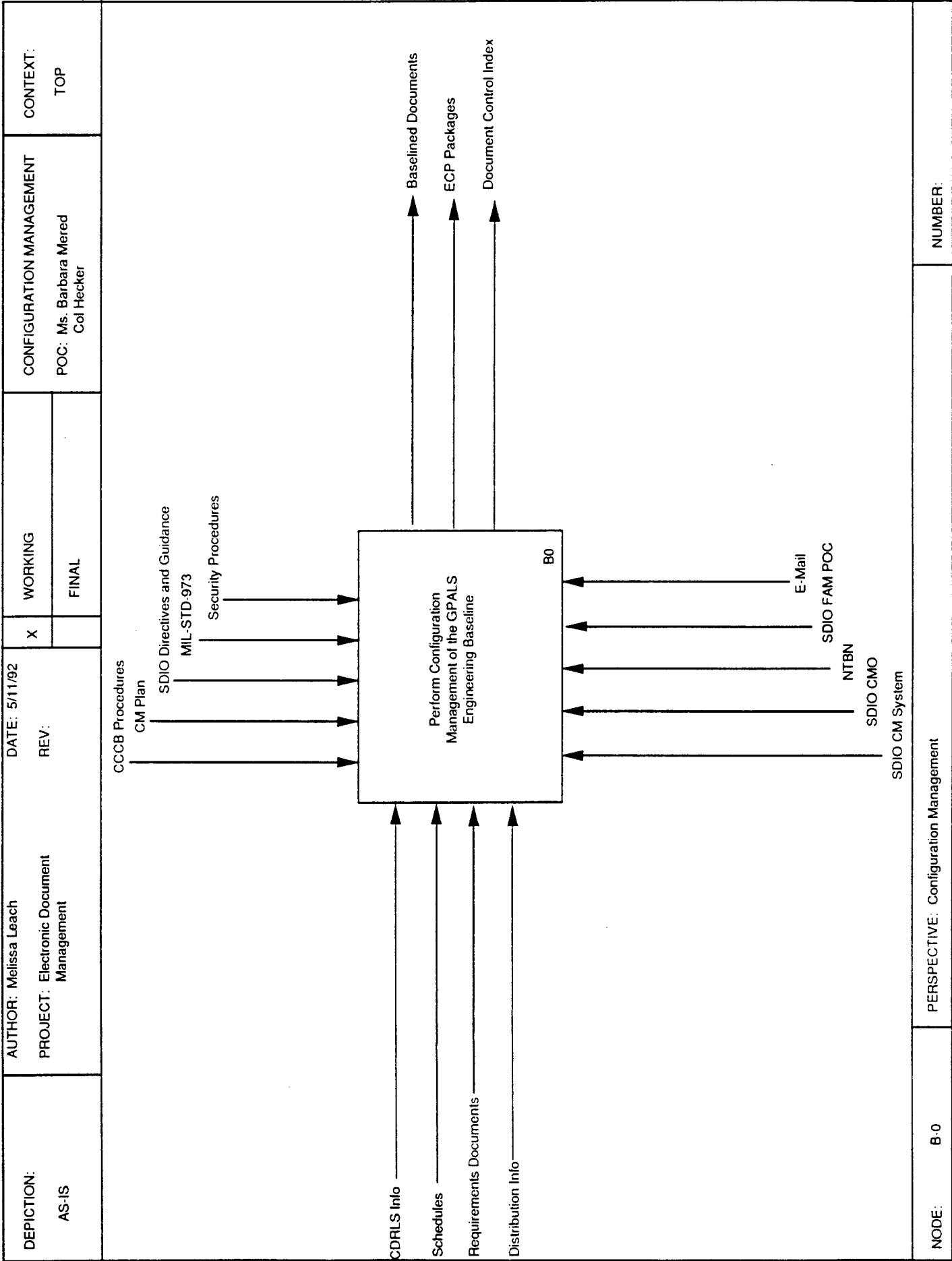

B0 - PERFORM CONFIGURATION MANAGEMENT OF THE GPALS ENGINEERING BASELINE

This includes incorporating the relevant schedules and CDRL requirements in order to establish a baseline schedule and produce the master document schedule.

B2 - CREATE BASELINE RECOMMENDATION PACKAGE

This includes procedures, the master document schedule, and distribution information that is used to recommend a baseline package.

B3 - ESTABLISH AND MAINTAIN GPALS CM LIBRARY

This includes acquiring the necessary documents and materials to maintain the Configuration Management Library. A Document Control Index records the materials maintained in this element.

B4 - CREATE/MANAGE CHANGE PACKAGE

This includes incorporating information from the configuration managed document and other material to create the change package that produces and updated document.

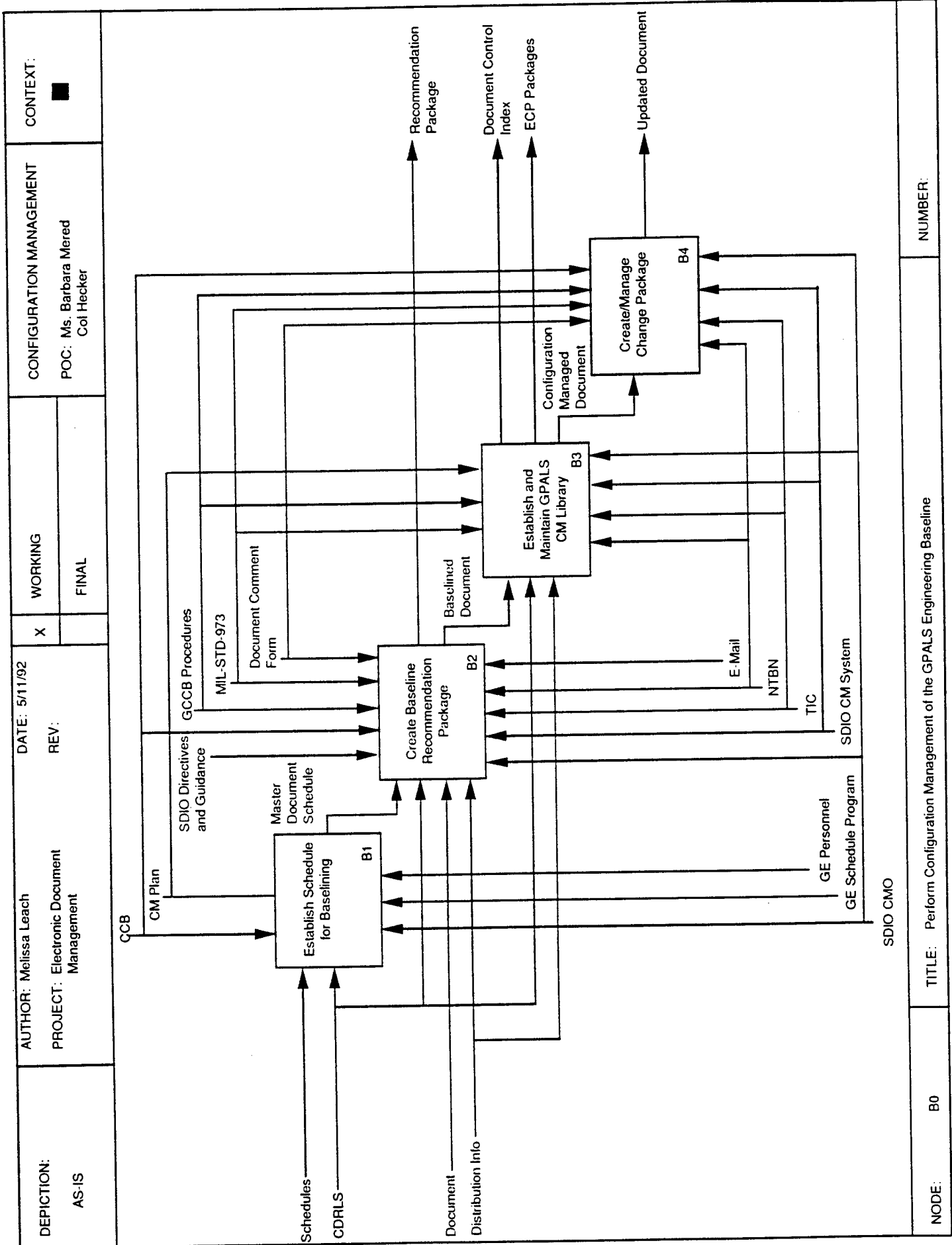

NUMBER:

TITLE: Perform Configuration Management of the GPALS Engineering Baseline

NODE: B0

B1 - ESTABLISH SCHEDULE FOR BASELINING

This material is not presented at this time.

B2 - CREATE BASELINE RECOMMENDATION PACKAGE

B21 - DISTRIBUTE DOCUMENT

This includes procedures to take a document and distribute it to the appropriate entities for review.

B22 - REVIEW DOCUMENT

This includes usage of the requirements and specifications that detail a documents content. The document is reviewed in light of the requirements and comments are attached.

B23 - TRACK DOCUMENT/COMMENTS

This includes procedures to track a document, so that its location is known at all times. Comments are received with the document and a recommendation package can be sent out.

DEPICTION: AS-IS	AUTHOR: Melissa Leach	DATE: 5/11/92	WORKING FINAL	CONFIGURATION MANAGEMENT POC: Ms. Barbara Mered Col Hecker	CONTEXT: <input checked="" type="checkbox"/> <input type="checkbox"/> <input type="checkbox"/>
	PROJECT: Electronic Document Management	REV:			

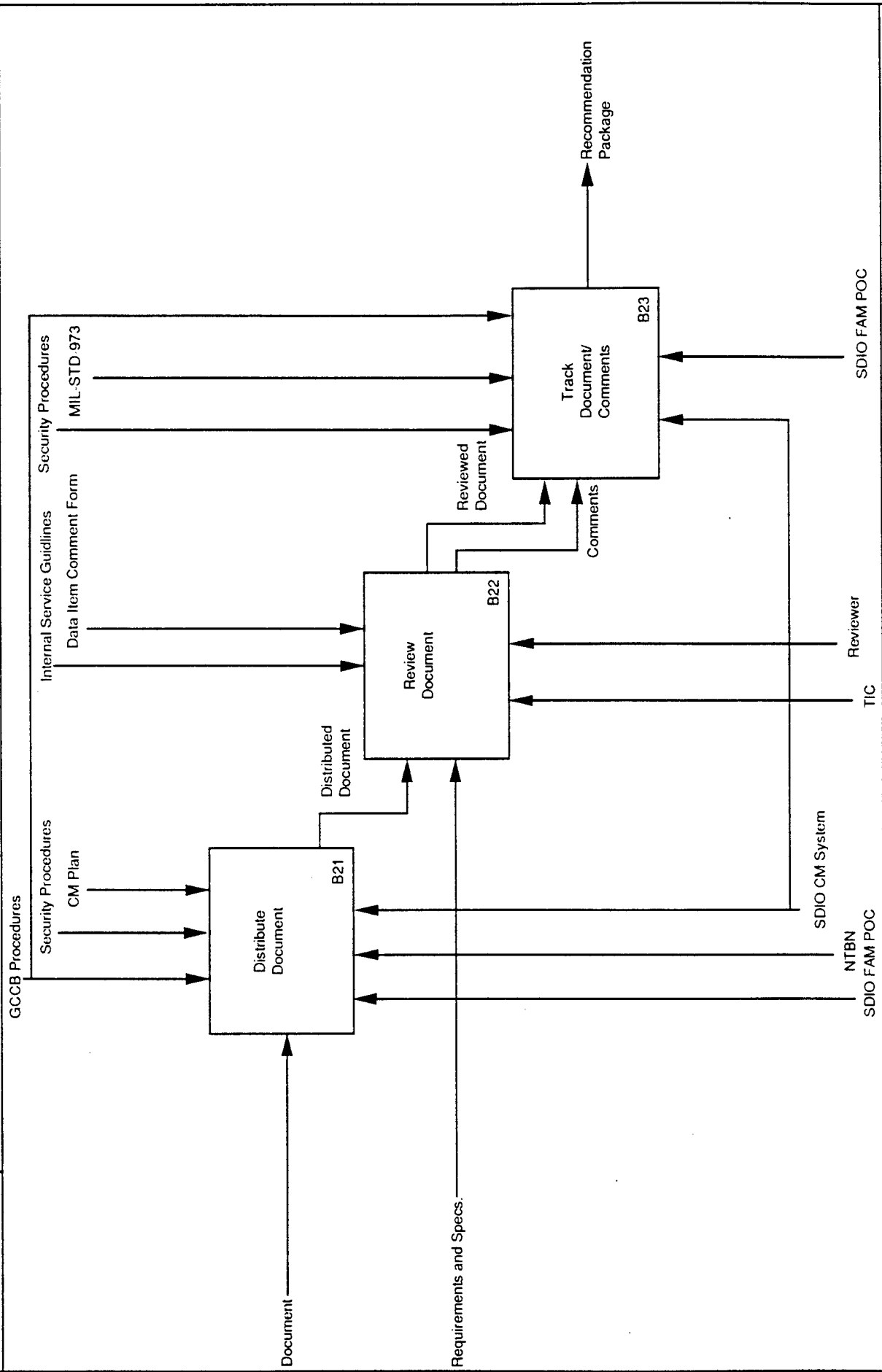

NODE: B2	TITLE: Create Baseline Recommendation Package	NUMBER:
----------	---	---------

B21 - DISTRIBUTE DOCUMENT

B211 - RECEIVE DOCUMENT

This includes procedures to ensure the document is received in the appropriate office.

B212 - DETERMINE DID COMPLIANCE

This includes examination of the document for DID compliance and certification that the document is compliant.

B213 - ESTABLISH LOG IN INFORMATION

This includes procedures to establish the login information necessary to track the document.

B214 - PERFORM ECP IMPACT ASSESSMENT

This includes gathering CDRL and schedule information necessary to perform ECP impact assessment.

B215 - DETERMINE DISTRIBUTION LIST

This includes obtaining distribution criteria, setting the distribution list, and ensuring that it complies with the established operating procedures.

B216 - NOTIFY RECIPIENTS OF DOCUMENT AVAILABILITY

This includes receipt of the distribution list and providing notification to the appropriate recipients of the document's availability.

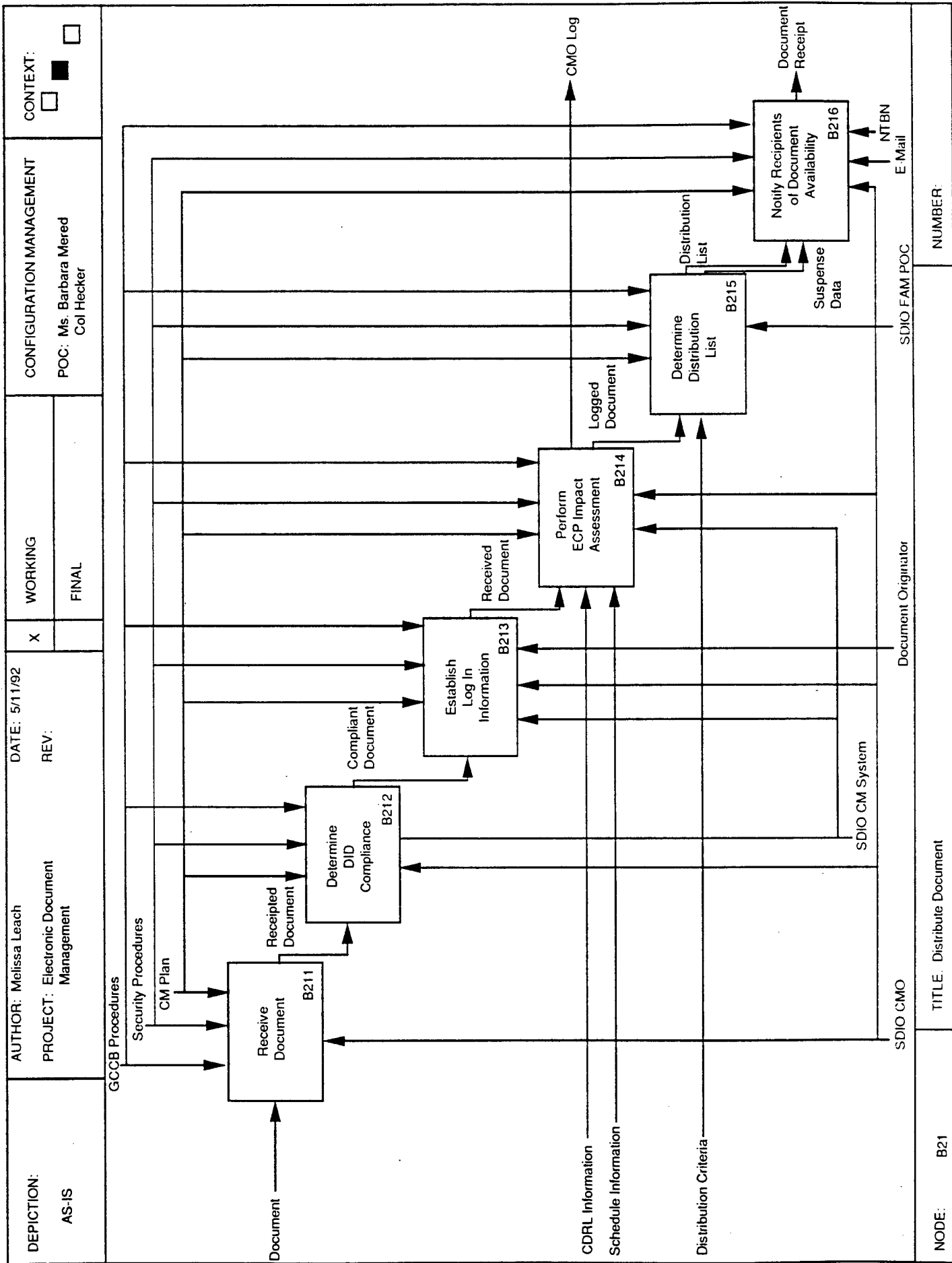

B22 - REVIEW DOCUMENT

B221 - ACKNOWLEDGE RECEIPT OF DOCUMENT

This includes following the appropriate security procedures to acknowledge the receipt of a particular document.

B222 - REVIEW DOCUMENT

This includes consideration of the appropriate requirements and specifications to provide a proper review of the document.

B223 - DEVELOP COMMENTS/ISSUES

This includes receipt of the reviewed document, noting the comments and issues that have arisen during the review, and providing hard copy of those comments and issues.

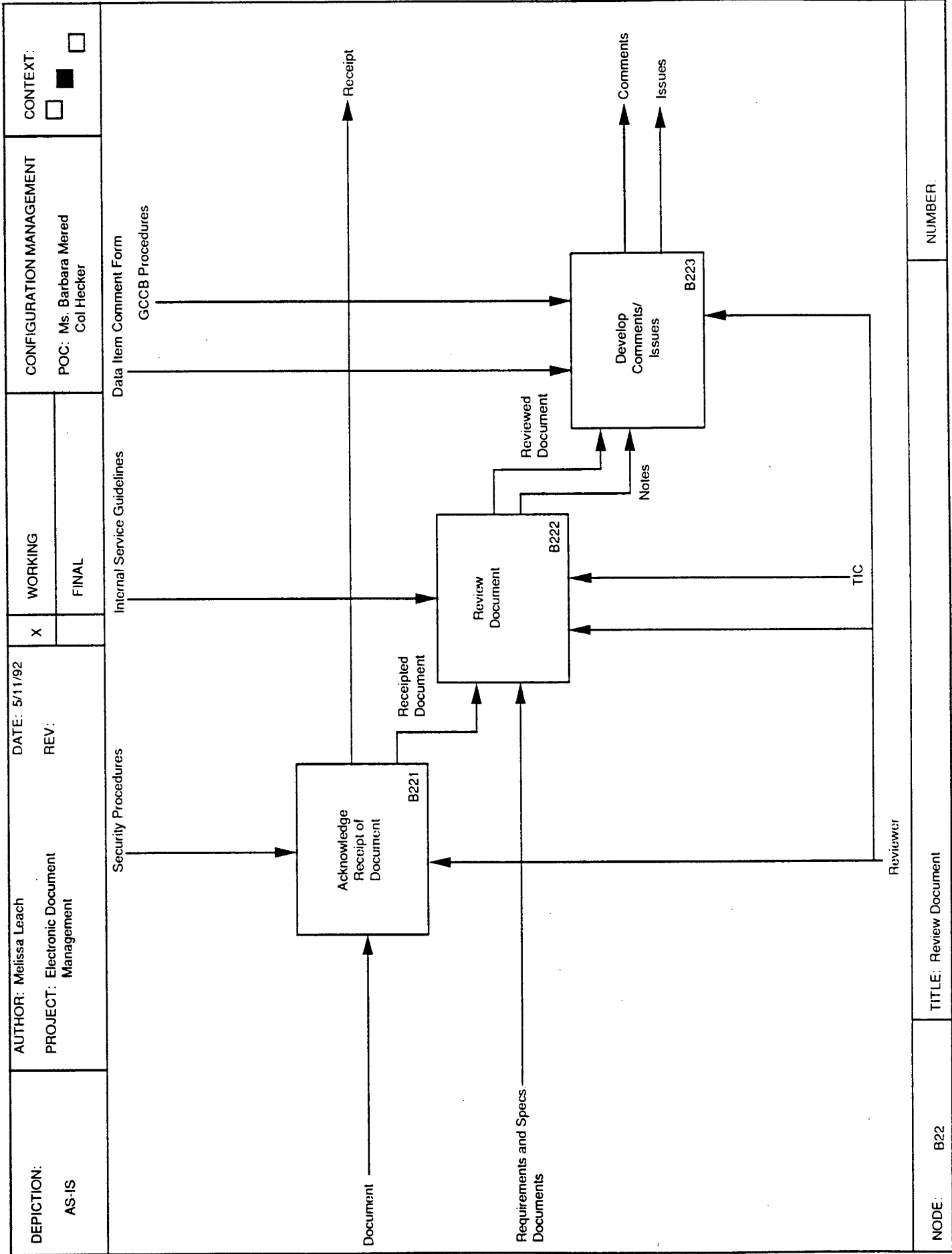

B23 - TRACK DOCUMENT/COMMENTS

B231 - INITIATE/MAINTAIN TRACKING

This includes observation of established procedures to track the document properly.

B232 - CONSOLIDATE AND PRIORITIZE COMMENTS

This includes taking the document and consolidating and prioritizing the comments that are included with the document.

B233 - DEVELOP RECOMMENDATION PACKAGE

This includes taking the consolidated and prioritized comments and developing a recommendation package.

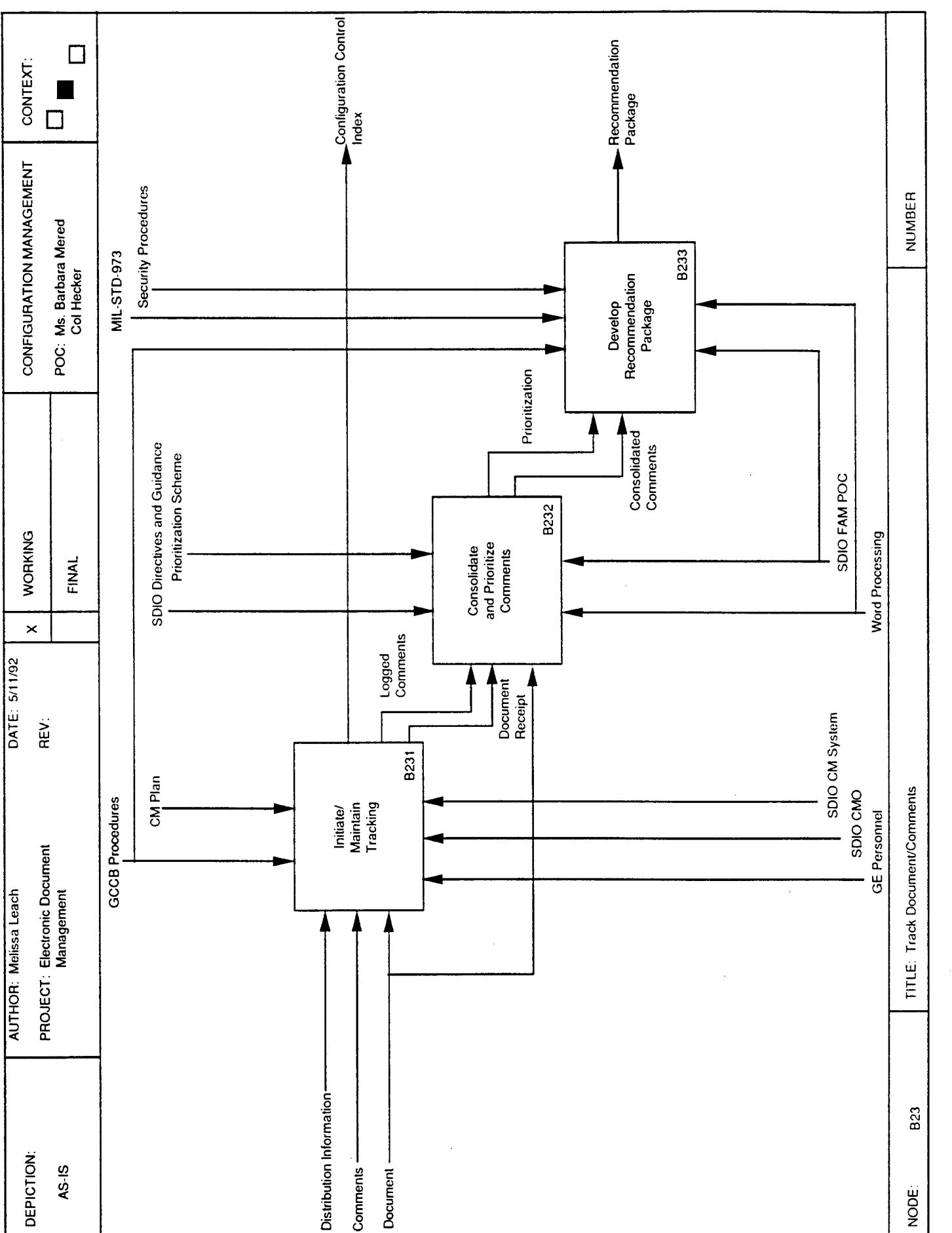

B3 - ESTABLISH AND MAINTAIN GPALS CM LIBRARY

B31 - DEVELOP CCB DOCUMENTATION

This includes usage of briefings and action items to develop Configuration Control Board documentation.

B32 - STORE APPROVED DOCUMENT IN READ-ONLY VERSION

This includes receipt of the configuration managed document and storage of the document in a read-only version.

B33 - UPDATE CM DATA BASE FILE

This includes usage of document data and CCB minutes to update the Configuration Management data base file.

B34 - MAINTAIN ECP PACKAGES

This includes procedures required to maintain ECP packages properly.



B31 - DEVELOP CCB DOCUMENTATION

B311 - DEVELOP CCB AGENDA

This includes obtaining input from CDRL information and ECP packages to develop the Configuration Control Board agenda.

B312 - DEVELOP CCB MINUTES

This includes usage of the CCB agenda and input from CCB notes to prepare the CCB minutes after a meeting.

B313 - UPDATE DOCUMENT

This includes usage of the results of CCB decisions to update the document.

B315 - VERIFY UPDATE INCORPORATION

This includes reviewing the updated document to verify the information in order to produce the configuration managed document.

DEPICTION: AS-IS	AUTHOR: Melissa Leach PROJECT: Electronic Document Management	DATE: 5/11/92 REV:	WORKING X	FINAL	CONTEXT: <input type="checkbox"/> <input checked="" type="checkbox"/> <input type="checkbox"/>
CONFIGURATION MANAGEMENT POC: Ms. Barbara Mered Col Hecker					

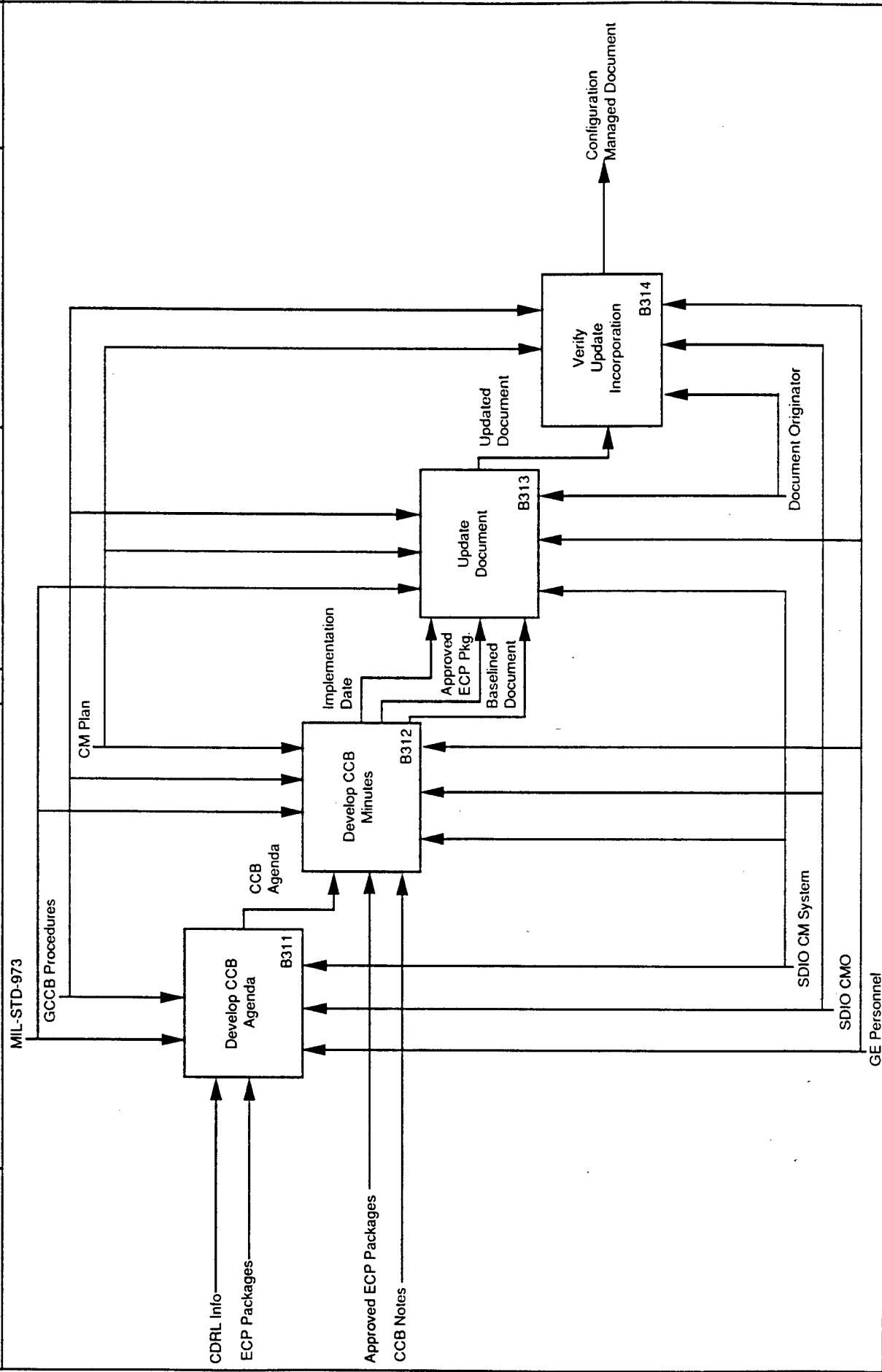

NODE: B31	TITLE: Develop CCB Documentation	NUMBER
-----------	----------------------------------	--------

B4 - CREATE/MANAGE CHANGE PACKAGE

B41 - DISTRIBUTE ECP

This includes observation of the document schedule and the appropriate security and GCCB procedures to distribute the Engineering Change Proposal (ECP).

B42 - REVIEW ECP

This includes usage of the appropriate requirements and specifications to review the ECP. Comments and evaluations are attached to the document.

B43 - TRACK ECP COMMENTS/EVALUATION

This includes ensuring that proper procedures for tracking ECP comments and evaluation are followed.

B44 - MAINTAIN STATUS ACCOUNTING

This includes using the login information in order to maintain an accounting recommendation package status.

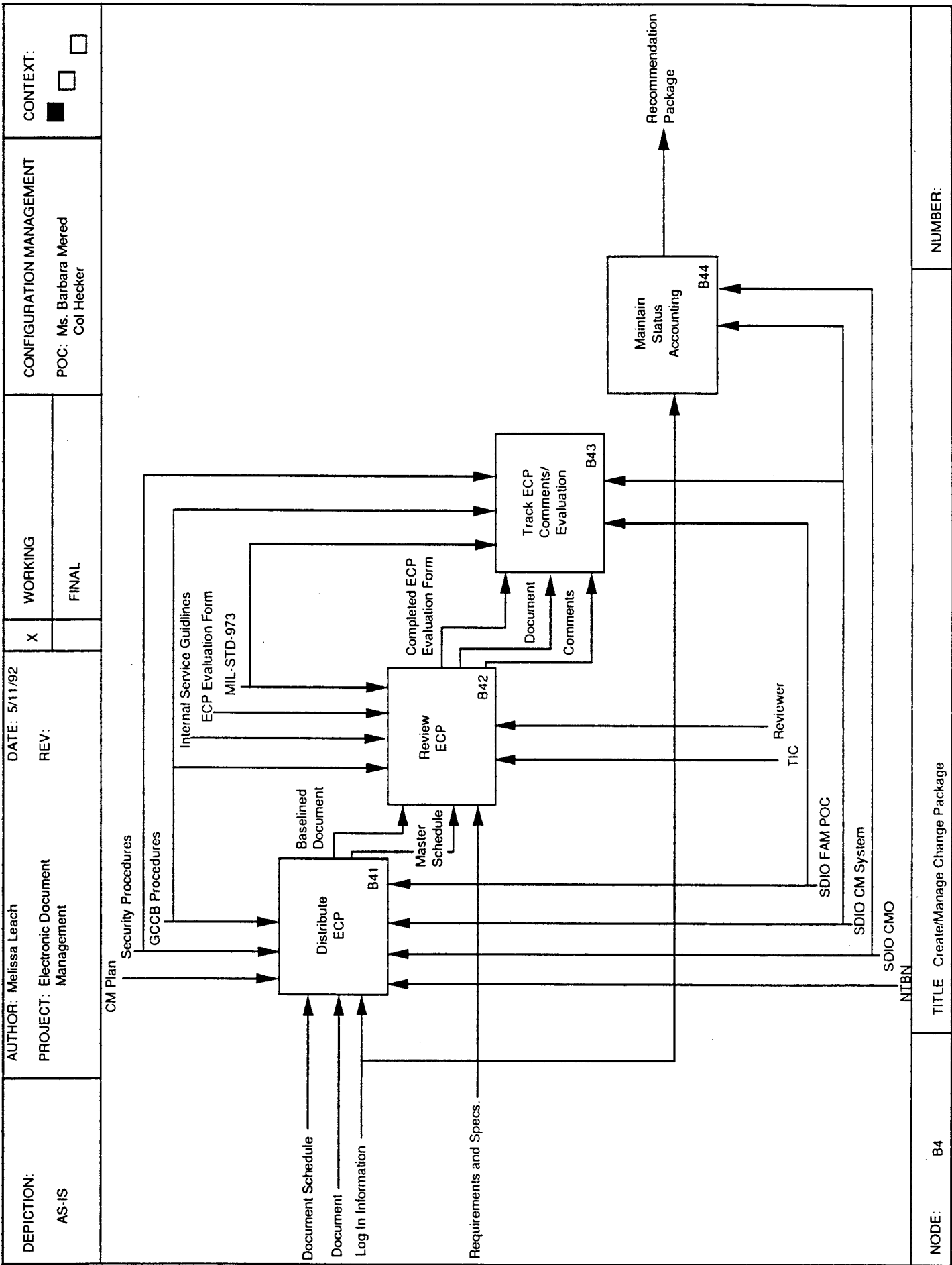

DEPICTION:  
AS-IS

AUTHOR: Melissa Leach  
PROJECT: Electronic Document Management

DATE: 5/11/92  
REV:

WORKING  
X

FINAL

CONFIGURATION MANAGEMENT  
POC: Ms. Barbara Mered  
Col Hecker

CONTEXT:  
■ □ □

NODE: B4  
TITLE: Create/Manage Change Package  
NUMBER:

B44 - MAINTAIN STATUS ACCOUNTING

B441 - TRACK STATUS

This includes tracking the status of a recommendation package and developing status files to account for the log in information.

B442 - PROVIDE STATUS REPORT

This includes using the status files to provide status reports on the recommendation package.

DEPICTION: AS-IS	AUTHOR: Melissa Leach PROJECT: Electronic Document Management	DATE: 5/11/92 REV:	X	WORKING FINAL	CONFIGURATION MANAGEMENT POC: Ms. Barbara Mered Col Hecker	CONTEXT: <input type="checkbox"/> <input checked="" type="checkbox"/> <input type="checkbox"/>
---------------------	--	-----------------------	---	------------------	--	---

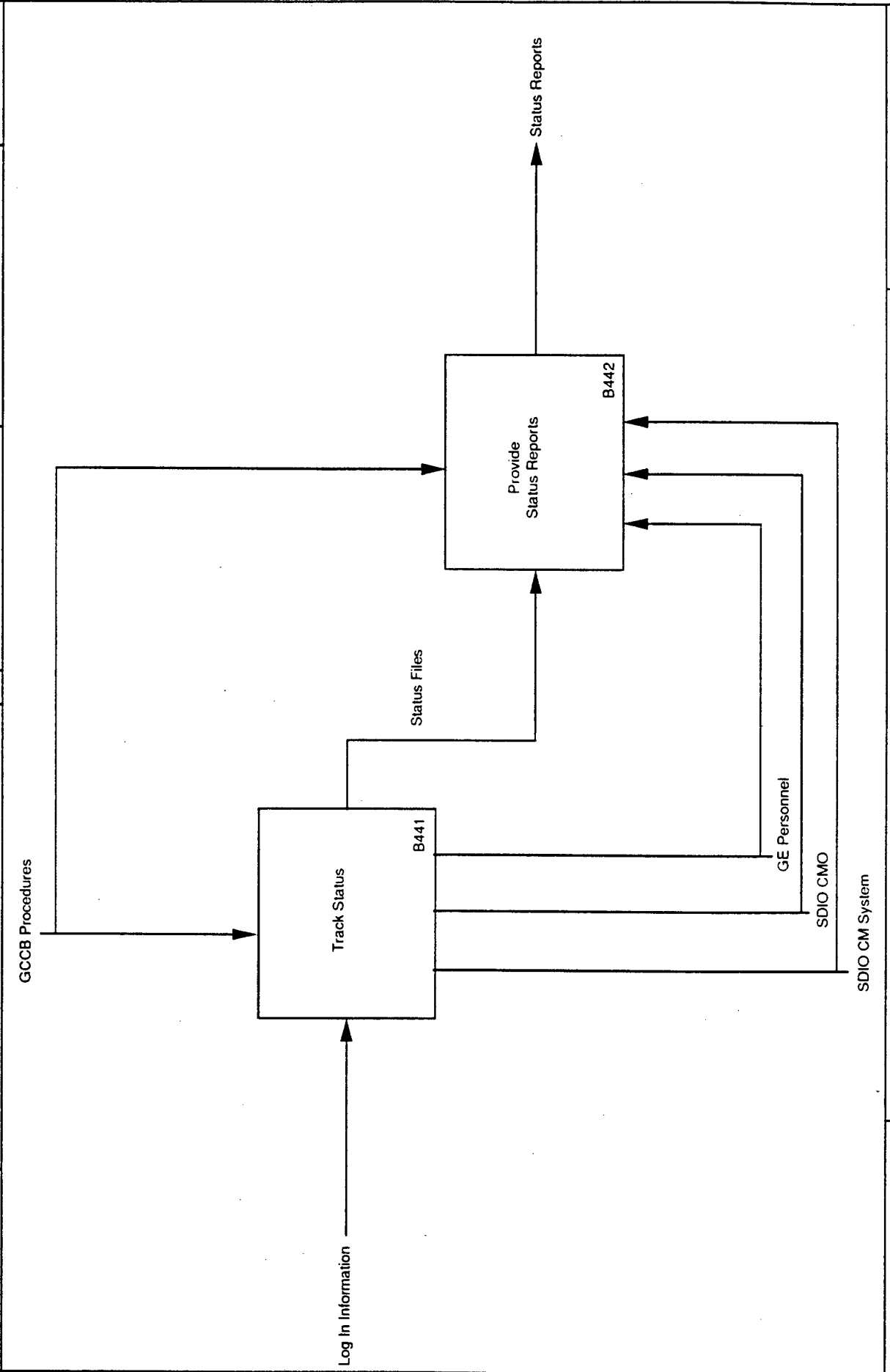

NODE: B44	TITLE: Maintain Status Accounting	NUMBER:
-----------	-----------------------------------	---------

### C. Management Operations

The Management Operations (MO) Directorate includes a number of responsibilities. This analysis focuses on the document management functions. The MO "As Is" Node Tree reflects the document management functions with which MO is concerned.

# MANAGEMENT OPERATIONS DOCUMENT MANAGEMENT NODE TREE (AS-IS ENVIRONMENT)

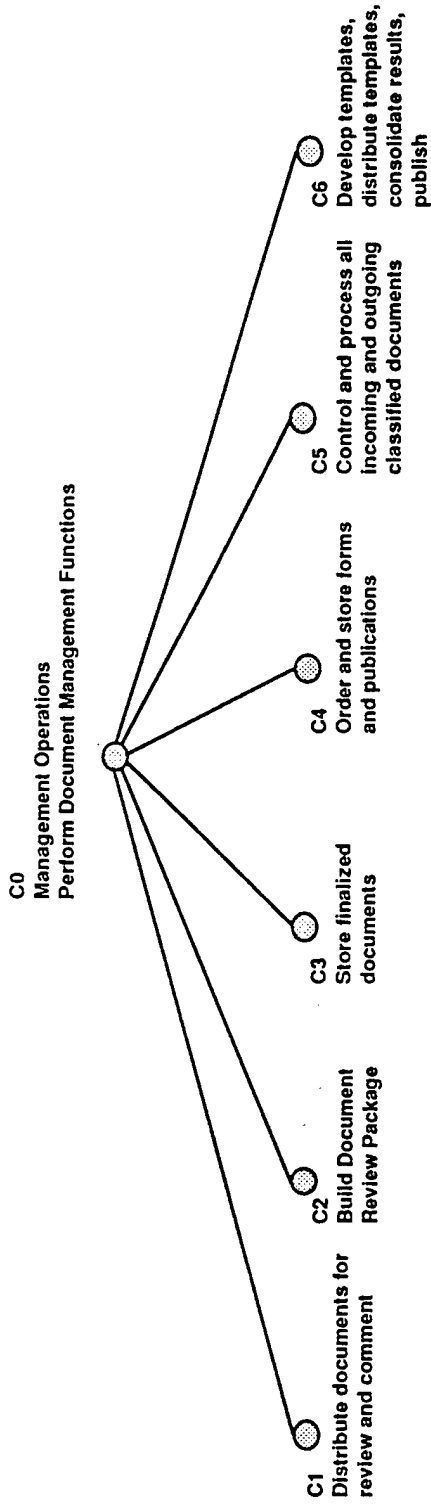

● - POTENTIALLY WITHIN PROGRAM SCOPE

IDEF

## MANAGEMENT OPERATIONS "AS IS" ACTIVITY MODEL

- C0 - This is the highest level of the Management Operations "As Is" Activity Model. It presents an overall picture of MO's document management activities.

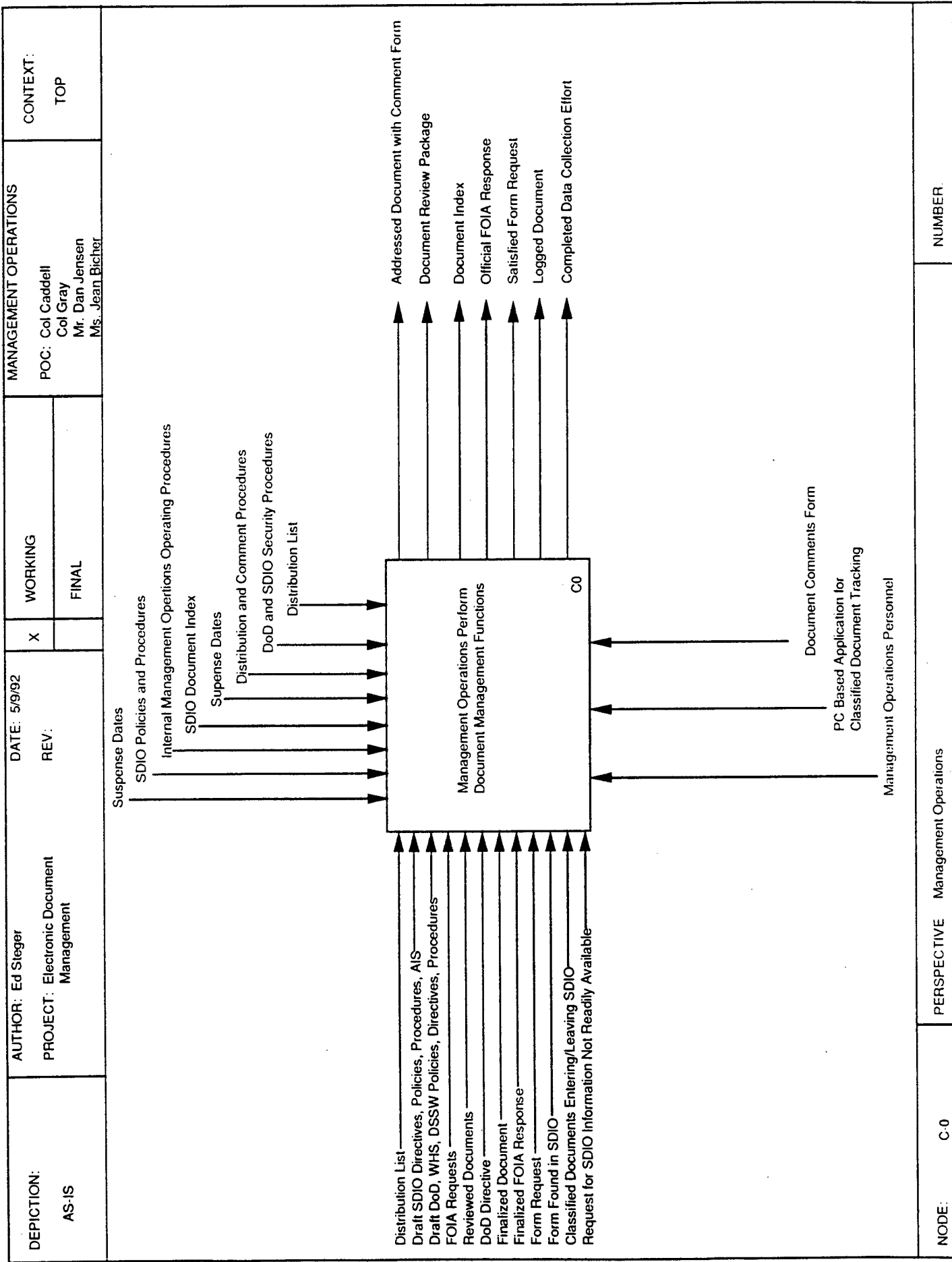

**NODE:** C-0

**PERSPECTIVE:** Management Operations

**NUMBER:**

C0 - MANAGEMENT OPERATIONS PERFORM DOCUMENT MANAGEMENT FUNCTIONS

C1 - DISTRIBUTE DOCUMENTS FOR REVIEW AND COMMENT

This includes procedures involved to distribute documents to the relevant entities so that they can be reviewed and comments can be received. Comment forms are attached to each document to facilitate the review process.

C2 - BUILD DOCUMENT REVIEW PACKAGE

This includes packaging the document to send to its owner once the review process is complete.

C3 - STORE FINALIZED DOCUMENTS

This includes procedures to store the finalized document within the Management Operations facility.

C4 - ORDER AND STORE FORMS AND PUBLICATIONS

This includes the procedures required to store the forms that track and control classified documents entering or leaving the SDIO facility. Once the procedures are followed the logged document may leave the SDIO facility for its destination.

C5 - CONTROL AND PROCESS ALL INCOMING AND OUTGOING CLASSIFIED DOCUMENTS

This includes procedures to ensure that all incoming and outgoing classified documents comply with proper controls. Forms are used to document compliance.

C6 - DEVELOP TEMPLATES, DISTRIBUTE TEMPLATES, CONSOLIDATE RESULTS, PUBLISH

This includes development of the templates that are used to track and control classified documents. The templates also are distributed to the proper entities. Results that are received are consolidated and published.

DEPICTION: AS-IS	AUTHOR: Ed Steger	DATE: 5/9/92	WORKING	MANAGEMENT OPERATIONS	CONTEXT:
	PROJECT: Electronic Document Management	REV:	FINAL	POC: Col Caddell Col Gray Mr. Dan Jensen Ms. Jean Blicher	■

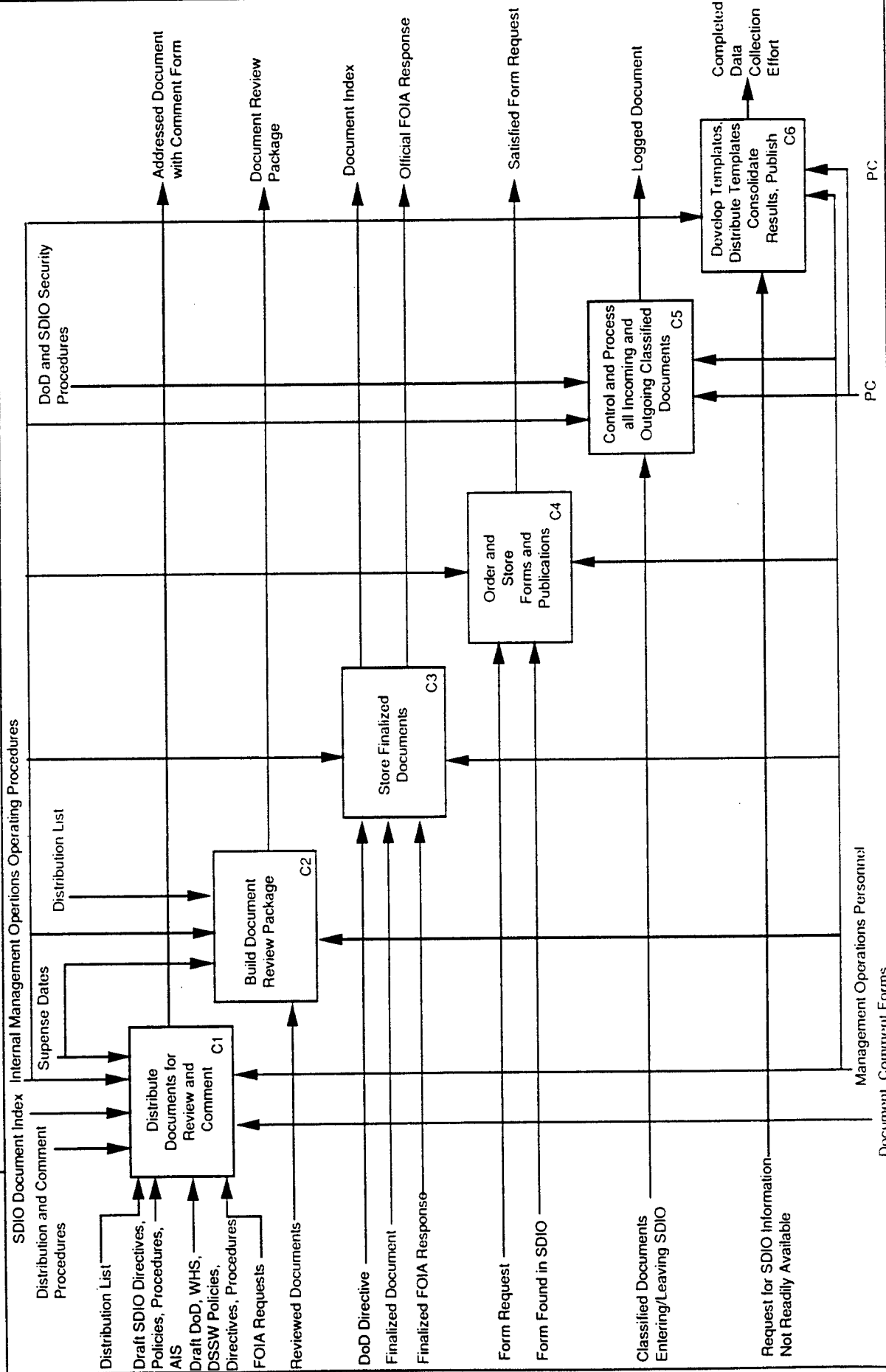

SDIO Document Index	Internal Management Operations Personnel	NUMBER
Document Commitment Forms	TITLE Management Operations Perform Document Management Functions	
NODE: C0		

D. External Affairs

The External Affairs office serves as the principal advisor to the Director and other SDIO personnel on Congressional and public affairs. There are two principal components of this office: Congressional affairs and public affairs. The Congressional affairs component monitors and coordinates all activities that relate to Congress' interaction with SDIO. The public affairs component provides the SDIO interface with the public.

The External Affairs "As Is" Node Tree depicts the overall structure of External Affairs activities. This analysis focuses on the document management functions of the External Affairs office. At a high level other office activities are represented; only the document management activities are decomposed.

# EXTERNAL AFFAIRS NODE TREE (AS-IS ENVIRONMENT)

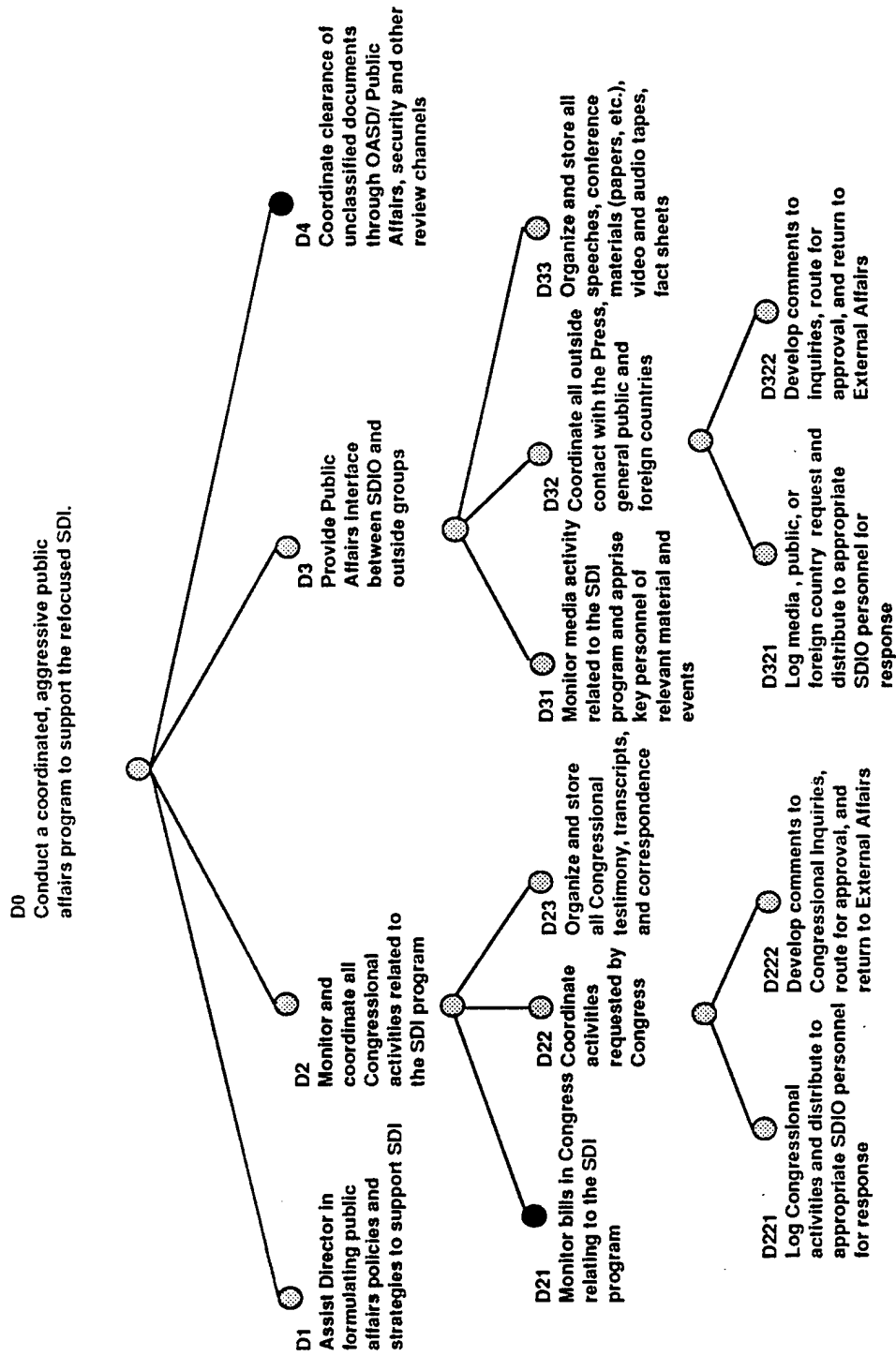

● = POTENTIALLY WITHIN PROGRAM SCOPE

IDEF

## EXTERNAL AFFAIRS "AS IS" ACTIVITY MODEL

- D0 - This is the highest level of the External Affairs "As Is" Activity Model. An overall picture of the office's activities is presented with a focus on document management functions.

DEPICTION: AS-IS	AUTHOR: Ed Steger PROJECT: Electronic Document Management	DATE: 5/4/92 REV:	X WORKING FINAL	EXTERNAL AFFAIRS POC: Col Jeff Furbank Major Carol Cencki Mr. Tom Johnson	CONTEXT: TOP
<p>External Affairs Strategic Plan and Standard Operating Procedures</p> <p>DoD and SDIO Security Directives</p> <div style="display: flex; justify-content: space-between;"> <div style="width: 45%;"> <p>Requests from SDIO Director</p> <p>Congressional Inquiries</p> <p>Press and Media Inquiries</p> <p>SDIO personnel request to release internal information</p> <p>Speech requirements by senior SDIO officials</p> <p>News articles and media reporting</p> <p>Congressional activities affecting SDI</p> <p>SDI conference support</p> </div> <div style="width: 10%; text-align: center;"> <p>Conduct a Coordinated, Aggressive Public Affairs Program to Support the Refocused SDI</p> <p>D0</p> </div> <div style="width: 45%;"> <p>Maintain calendar of Legislative events</p> <p>Fact Sheets and Issue Papers</p> <p>Media responses</p> <p>Briefings</p> <p>Audio Tapes and Videos of Briefings and News Conferences</p> <p>Congressional Responses</p> <p>Congressional Testimony</p> <p>SDI Material Sent to OASD/Public Affairs for Public Release Approval</p> <p>Biographies</p> </div> </div> <p>Legislate (Commercial Data Base)</p> <p>News Wire Service (API, UPI)</p> <p>External Affairs Personnel</p>					
NODE: D-0	PERSPECTIVE: Public Affairs				NUMBER:

D0 - CONDUCT A COORDINATED, AGGRESSIVE PUBLIC AFFAIRS PROGRAM TO SUPPORT THE REFOCUSED SDI

D1 - ASSIST DIRECTOR IN FORMULATING PUBLIC AFFAIRS POLICIES AND STRATEGIES TO SUPPORT SDI

This includes development of public affairs policy and strategy for presentation to the SDIO Director. This will assist in presenting the public with the best possible information concerning SDI activities.

D2 - MONITOR AND COORDINATE ALL CONGRESSIONAL ACTIVITIES RELATED TO THE SDI PROGRAM

This includes monitoring all Congressional debate and action with regard to SDI, responding to Congressional correspondence and inquiries, and providing expert testimony to Congress when it is required.

D3 - PROVIDE PUBLIC AFFAIRS INTERFACES BETWEEN SDIO AND OUTSIDE GROUPS

This includes monitoring public debate and concerns about SDI. Fact sheets and issue papers for the press and public distribution are prepared. Media briefings are provided. A file of SDIO biographies is maintained.

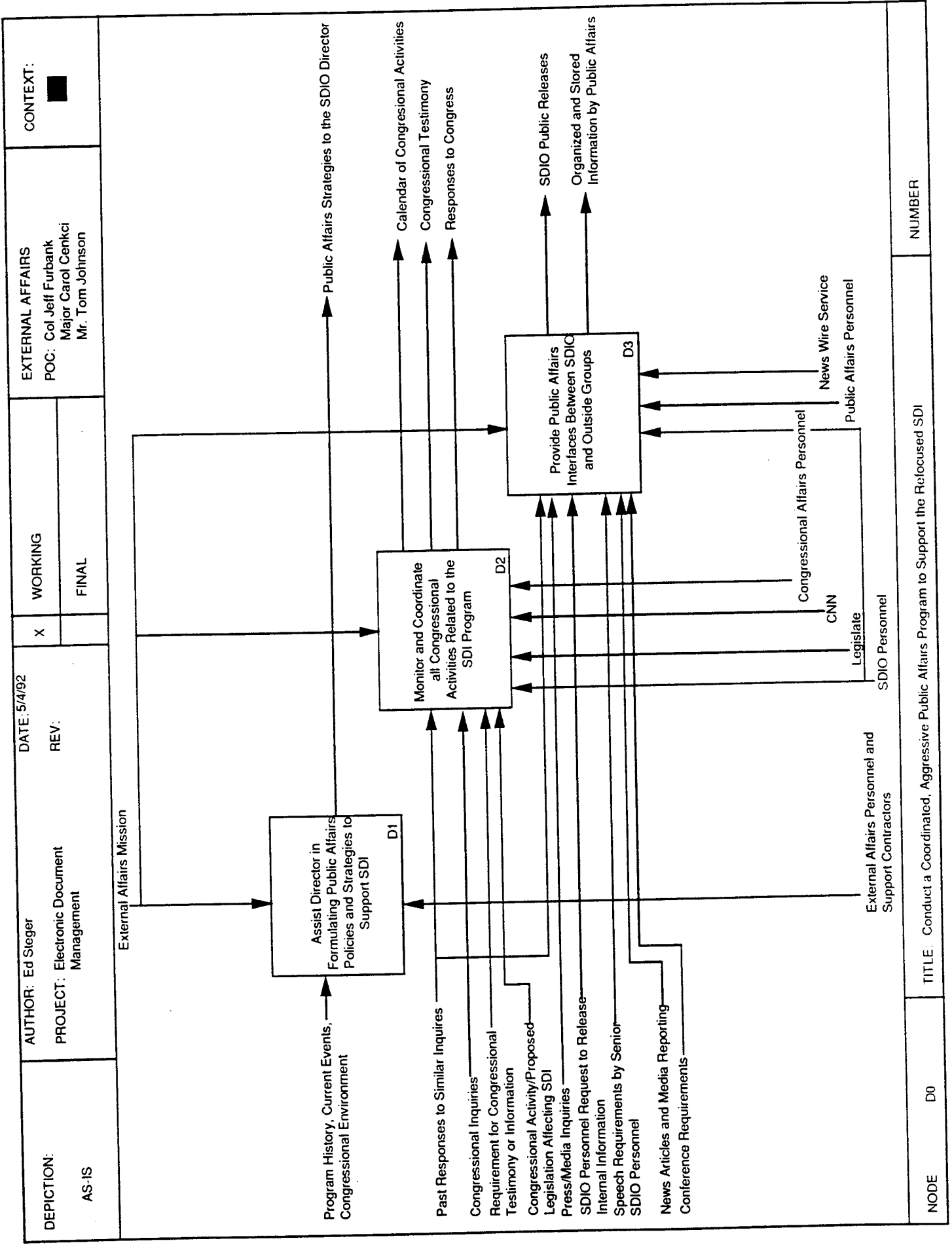

D2 - MONITOR AND COORDINATE ALL CONGRESSIONAL ACTIVITIES RELATED TO THE SDI PROGRAM

D21 - MONITOR BILLS IN CONGRESS RELATING TO THE SDI PROGRAM

This includes monitoring all bills in Congress or pending in Congress to determine their impact on SDIO. Senior SDI Personnel are notified of pending legislation. A Calendar of Congressional events is maintained.

D22 - COORDINATE ACTIVITIES REQUESTED BY CONGRESS

This includes preparation of responses to Congressional questions on matters relating to SDI. When official testimony is required for Congressional hearings, this material is prepared and assembled.

D23 - ORGANIZE AND STORE ALL CONGRESSIONAL TESTIMONY, TRANSCRIPTS, AND CORRESPONDENCE

This includes organizing, storing, and maintaining all documents that pertain to Congressional interaction with SDIO. This includes testimony, pertinent legislation. Congressional questions and SDIO responses to those questions.

DEPICTION: AS-IS	AUTHOR: Ed Steger PROJECT: Electronic Document Management	DATE: 5/4/92 REV:	X	WORKING FINAL	EXTERNAL AFFAIRS POC: Col Jeff Furbank Major Carol Centki Mr. Tom Johnson	CONTEXT: <input checked="" type="checkbox"/> <input type="checkbox"/> <input type="checkbox"/>
---------------------	--	----------------------	---	------------------	--	---

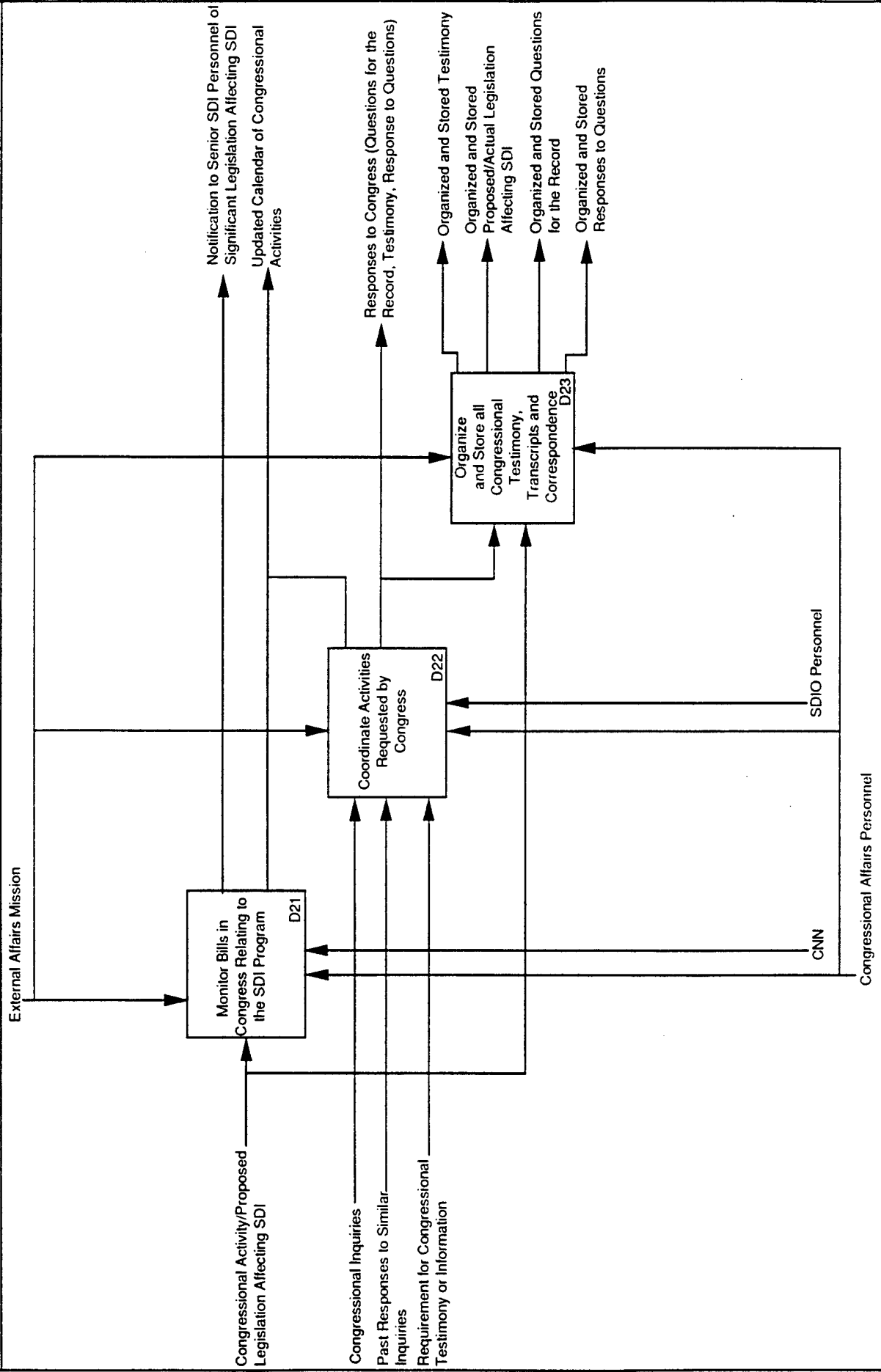

NODE D2	TITLE Monitor and Coordinate all Congressional Activities Related to the SDI Program	NUMBER
------------	---	--------

D3 - PROVIDE PUBLIC AFFAIRS INTERFACES BETWEEN SDIO AND OUTSIDE GROUPS

D31 - MONITOR MEDIA ACTIVITIES RELATED TO THE SDI PROGRAM AND APPRISE KEY PERSONNEL OF RELEVANT MATERIAL AND EVENTS

This includes monitoring of news articles and reports related to the SDI program. Relevant SDI-related material can become the basis for SDIO news releases.

D32 - COORDINATE ALL OUTSIDE CONTACT WITH THE PRESS, GENERAL PUBLIC, AND FOREIGN COUNTRIES

This includes consideration of media inquiries, SDIO personnel requests to release information, and requests from the SDIO Director. Internal SDIO approval for release is obtained. This includes approval from the Security office. Then press releases and responses to inquiries may be released. Materials for SDI conferences and SDI related tapes may be released.

D33 - ORGANIZE AND STORE ALL SPEECHES, CONFERENCE MATERIALS, VIDEO AND AUDIO TAPES, FACT SHEETS

This includes organization of all relevant SDI-related media materials that have been or may be released to the public and storing them for future reference.

DEPICTION: AS-IS	AUTHOR: Ed Steger PROJECT: Electronic Document Management	DATE: 5/4/92 REV:	X	WORKING FINAL	EXTERNAL AFFAIRS POC: Col Jeff Furbank Major Carol Centki Mr. Tom Johnson	CONTEXT: <input checked="" type="checkbox"/> <input type="checkbox"/>
---------------------	--	----------------------	---	------------------	--	--

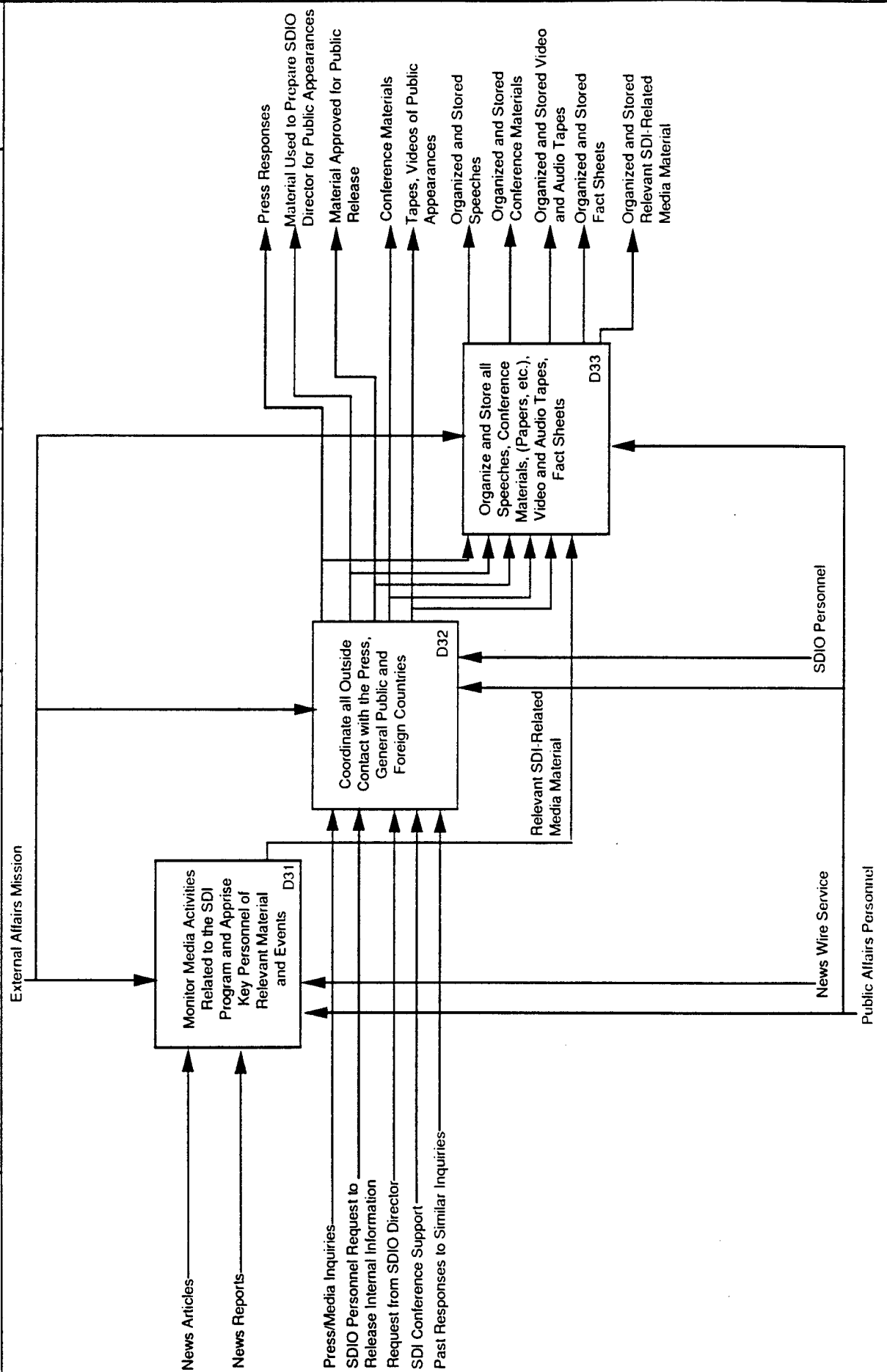

NODE D3	TITLE: Provide Public Affairs Interface Between SDIO and Outside Groups	NUMBER
------------	---	--------

D22 - COORDINATE ACTIVITIES REQUESTED BY CONGRESS

D221 - LOG CONGRESSIONAL ACTIVITIES AND DISTRIBUTE TO APPROPRIATE SDI PERSONNEL FOR RESPONSE

This includes maintaining a log of all SDI-related Congressional requests. Requests are routed to appropriate SDI personnel so that proper response can be made.

D222 - DEVELOP COMMENTS TO CONGRESSIONAL INQUIRIES, ROUTE FOR APPROVAL, AND RETURN TO EXTERNAL AFFAIRS

This includes reviewing previous responses to Congressional inquiries and developing the current comments so that consistency is maintained. Responses are routed for approval and sent to the appropriate Congressional office. If testimony before Congressional committees is required, this is arranged.



D32 - COORDINATE ALL OUTSIDE CONTACT WITH THE PRESS, GENERAL PUBLIC, AND FOREIGN COUNTRIES AND GAIN INTERNAL SDIO APPROVALS

D321 - LOG MEDIA, PUBLIC, OR FOREIGN COUNTRY REQUEST AND DISTRIBUTE TO APPROPRIATE SDIO PERSONNEL FOR RESPONSE

This includes maintaining a log of all incoming requests for release of SDI-related information to the media, the public, or to a foreign entity. The requests are routed to the appropriate SDIO personnel for consideration and approval.

D322 - DEVELOP COMMENTS TO INQUIRIES, ROUTE FOR APPROVAL, AND RETURN TO EXTERNAL AFFAIRS

This includes reviewing previous responses to media and public inquiries and developing current comments so that consistency is maintained. Responses are routed for approval and released to the media or other requestor. If a public speech is required, this is arranged.

DEPICTION: AS-IS	AUTHOR: Ed Steger PROJECT: Electronic Document Management	DATE: 5/4/92 REV:	X	WORKING	EXTERNAL AFFAIRS POC: Col Jeff Furbank Major Carol Cencki Mr. Tom Johnson	CONTEXT: <input type="checkbox"/> <input checked="" type="checkbox"/> <input type="checkbox"/>
				FINAL		

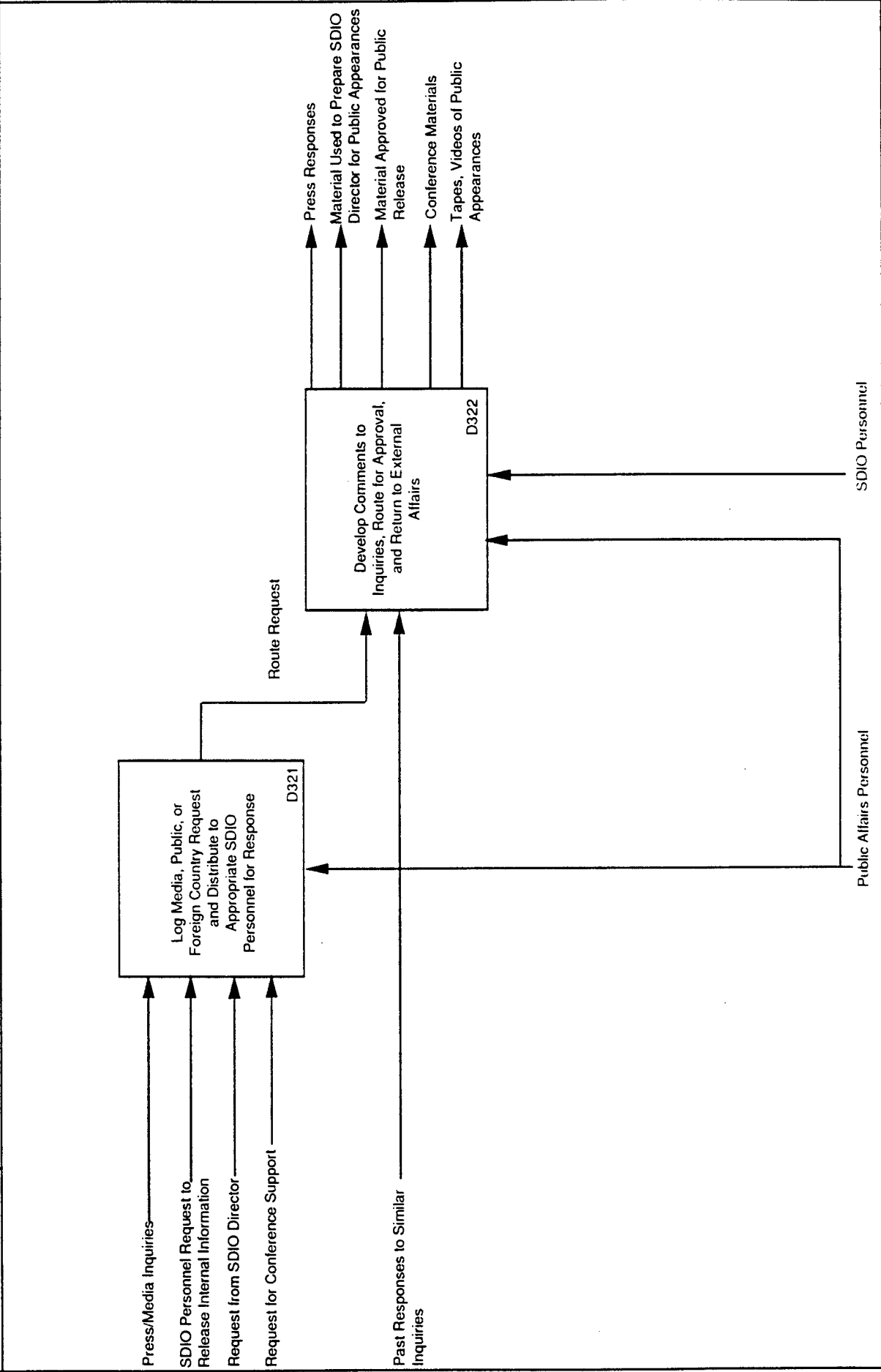

NODE	D32	TITLE	Coordinate all Outside Contact with the Press., General Public and Foreign Countries	NUMBER:
------	-----	-------	--	---------

E. Security

The Security element of the Security, Intelligence, and Countermeasures Directorate has major document management requirements. Its principal activity is to develop security policies for the protection of SDI information, programs, personnel, facilities, and systems. The Security Office also provides management and oversight of all classification management and information security. Within this mission is the responsibility for SDI Security Classification Guides.

The Security, Intelligence, and Countermeasures "As Is" Node Tree shows the overall structure of the Directorate. The Security Office document management functions are decomposed in some detail. Since no activity model was generated for E2, Perform Intelligence and Countermeasures Activities, the EO activity model was not generated.

# SECURITY, INTELLIGENCE AND COUNTERMEASURES NODE TREE (AS-IS ENVIRONMENT)

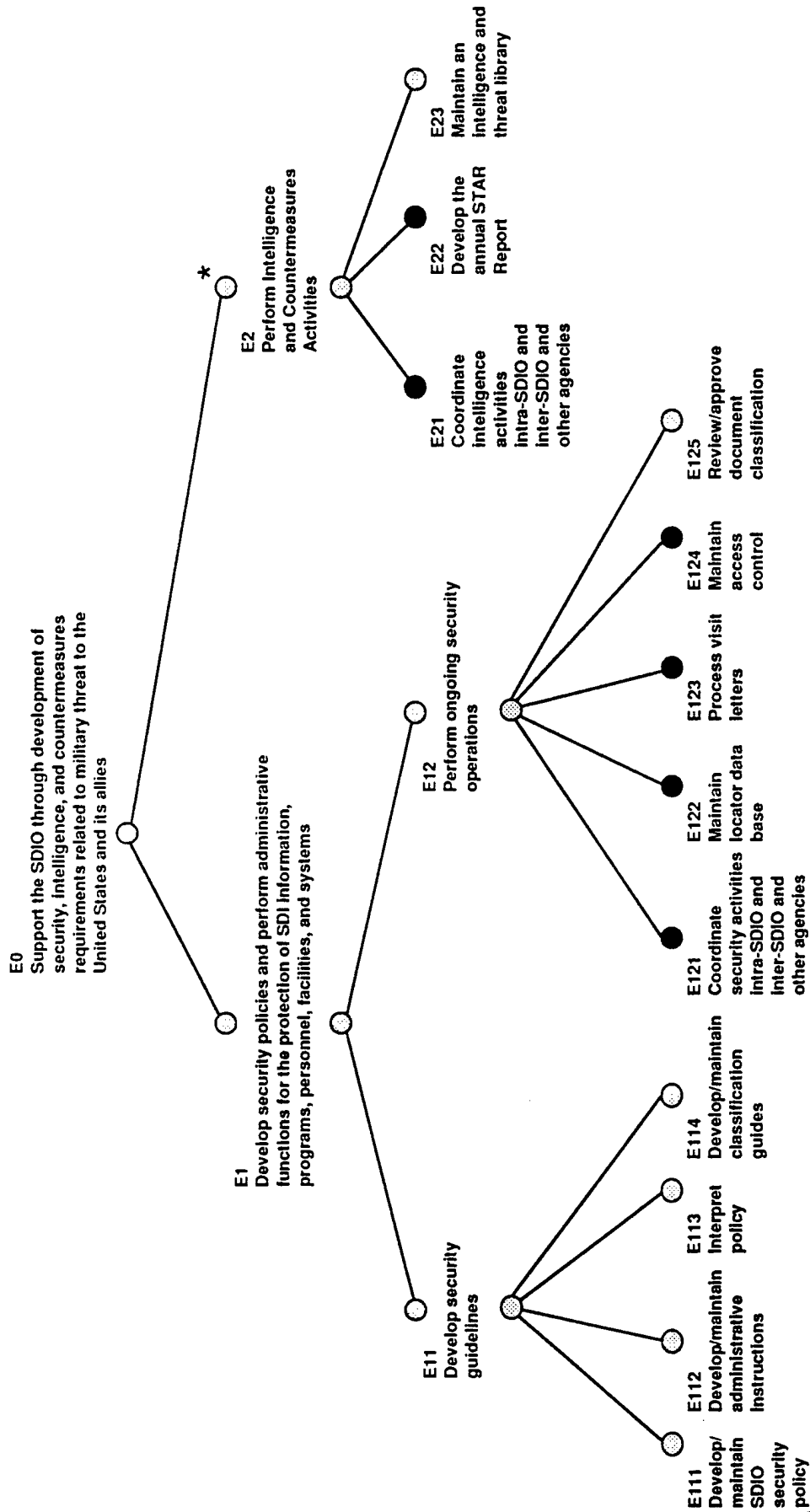

\* = ACTIVITY MODEL FOR THIS NODE HAS NOT BEEN DEVELOPED

○ = POTENTIALLY WITHIN PROGRAM SCOPE

IDEF

## SECURITY, INTELLIGENCE, AND COUNTERMEASURES "AS IS" ACTIVITY MODEL

- E0 - This is the highest level of the Security, Intelligence, and Countermeasures Activity Model. An overall picture of the Directorate's activities is described. These revolve around the mission to support the SDIO through development of security, intelligence, and countermeasures requirements related to military threat to the United States and its allies.

E0 - SUPPORT THE SDIO THROUGH DEVELOPMENT OF SECURITY, INTELLIGENCE, AND COUNTERMEASURES REQUIREMENTS RELATED TO MILITARY THREAT TO THE UNITED STATES AND ITS ALLIES

E1 - DEVELOP SECURITY POLICIES AND PERFORM ADMINISTRATIVE FUNCTIONS FOR THE PROTECTION, PROGRAMS, PERSONNEL, FACILITIES, AND SYSTEMS

This includes an evaluation of existing security policy and procedures as they apply to SDI-related research and technology. This knowledge is used to develop Security Classification Guides, Administrative Instructions, and other security-related documents.

E2 - PERFORM INTELLIGENCE AND COUNTERMEASURES ACTIVITIES

These activities are not developed for this analysis.

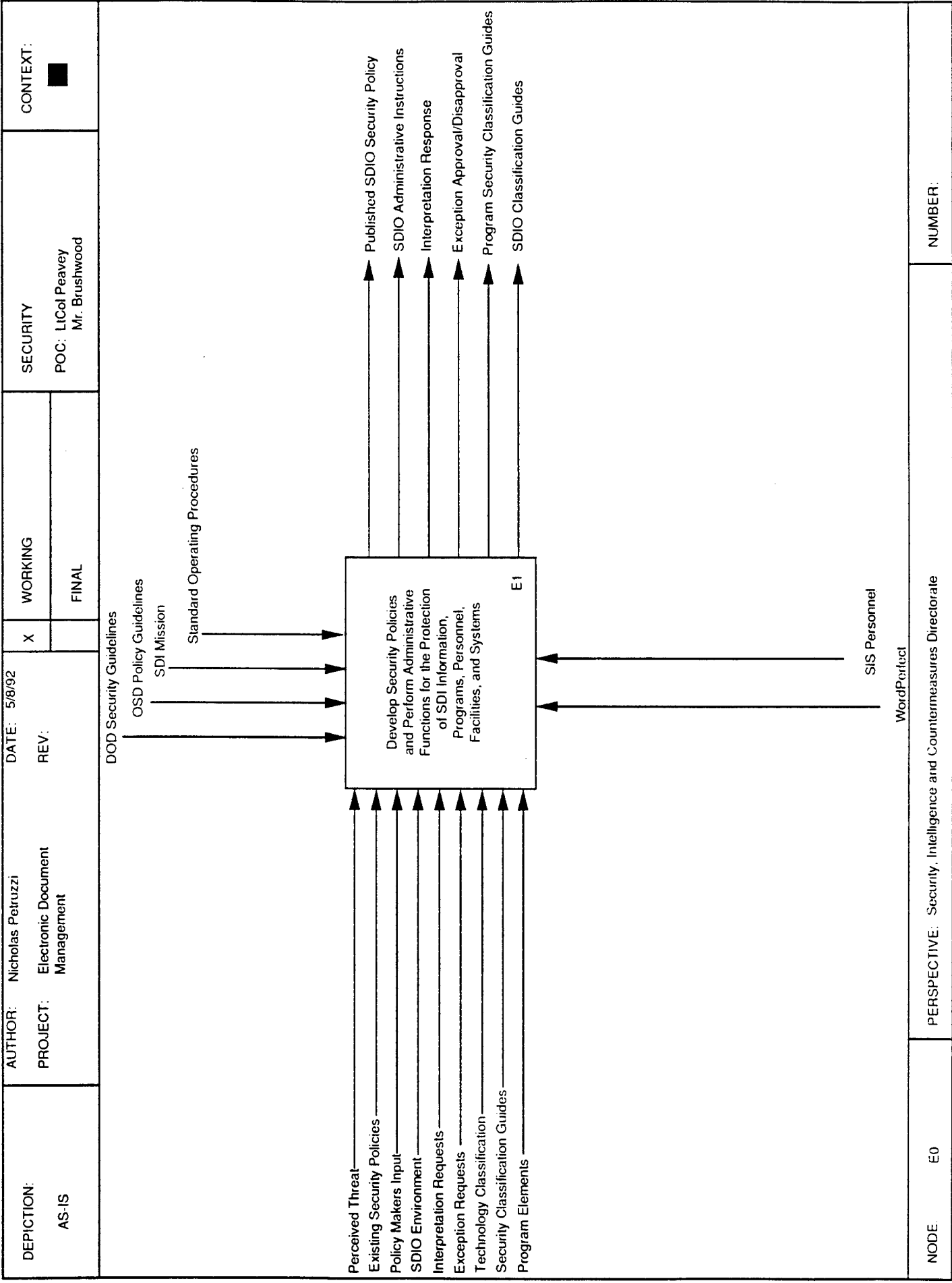

E1 - DEVELOP SECURITY POLICIES AND PERFORM ADMINISTRATIVE FUNCTIONS FOR THE PROTECTION, PROGRAMS, PERSONNEL, FACILITIES, AND SYSTEMS

E11 - DEVELOP SECURITY GUIDELINES

This includes the procedures to develop Security Classification Guides, Administrative Instructions, and other SDI-related security documents. Exceptions to security policy and procedure are considered and approved or disapproved.

E12 - PERFORM ONGOING SECURITY OPERATIONS

This includes the administrative procedures to maintain the Security Office's functions, as well as the review and approval of document classifications.

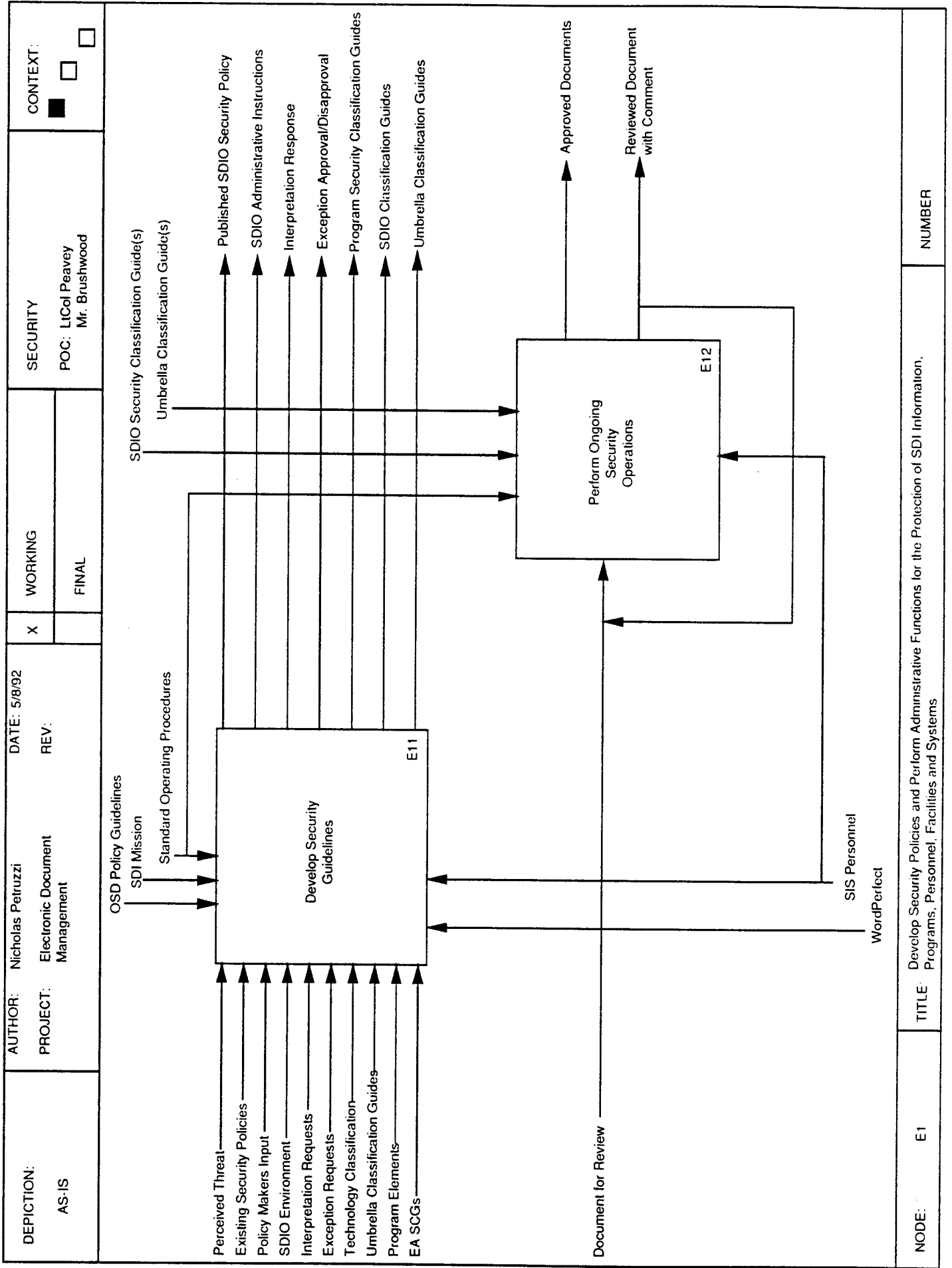

NODE: E1

TITLE: Develop Security Policies and Perform Administrative Functions for the Protection of SDI Information, Programs, Personnel, Facilities and Systems

NUMBER

E11 - DEVELOP SECURITY GUIDELINES

E111 - DEVELOP/MAINTAIN SDIO SECURITY POLICY

This includes understanding existing policy and decisions by policy-makers, applying OSD policy guidelines, and developing and publishing SDIO security policy.

E112 - DEVELOP/MAINTAIN ADMINISTRATIVE INSTRUCTIONS

This includes the processes involved in developing, maintaining, and producing SDIO administrative instructions as they pertain to SDIO security matters.

E113 - INTERPRET POLICY AND ASSESS PROCEDURE

This includes the receipt of security policy interpretation requests and security policy exception requests. Each is considered in the light of the request's circumstances and the national interest. Interpretations are provided and exception requests are approved or denied.

E114 - DEVELOP/MAINTAIN CLASSIFICATION GUIDES

This includes responding to the Program Management Agreement's requirement for a Security Classification Guide (SCG). The umbrella SDIO SCG, related technology classification guidelines, and previous practice for similar projects are considered. The Program Manager is responsible for producing the SCG applicable to the project described in the PMA. The umbrella SDIO SCG is also maintained and modified as circumstances require this action.

DEPICTION: AS-IS	AUTHOR: Nicholas Petruzzi	DATE: 5/8/92	WORKING	SECURITY	CONTEXT:
	PROJECT: Electronic Document Management	REV:	X	POC: LtCol Peavey Mr. Brushwood	<input type="checkbox"/> <input checked="" type="checkbox"/>
			FINAL		

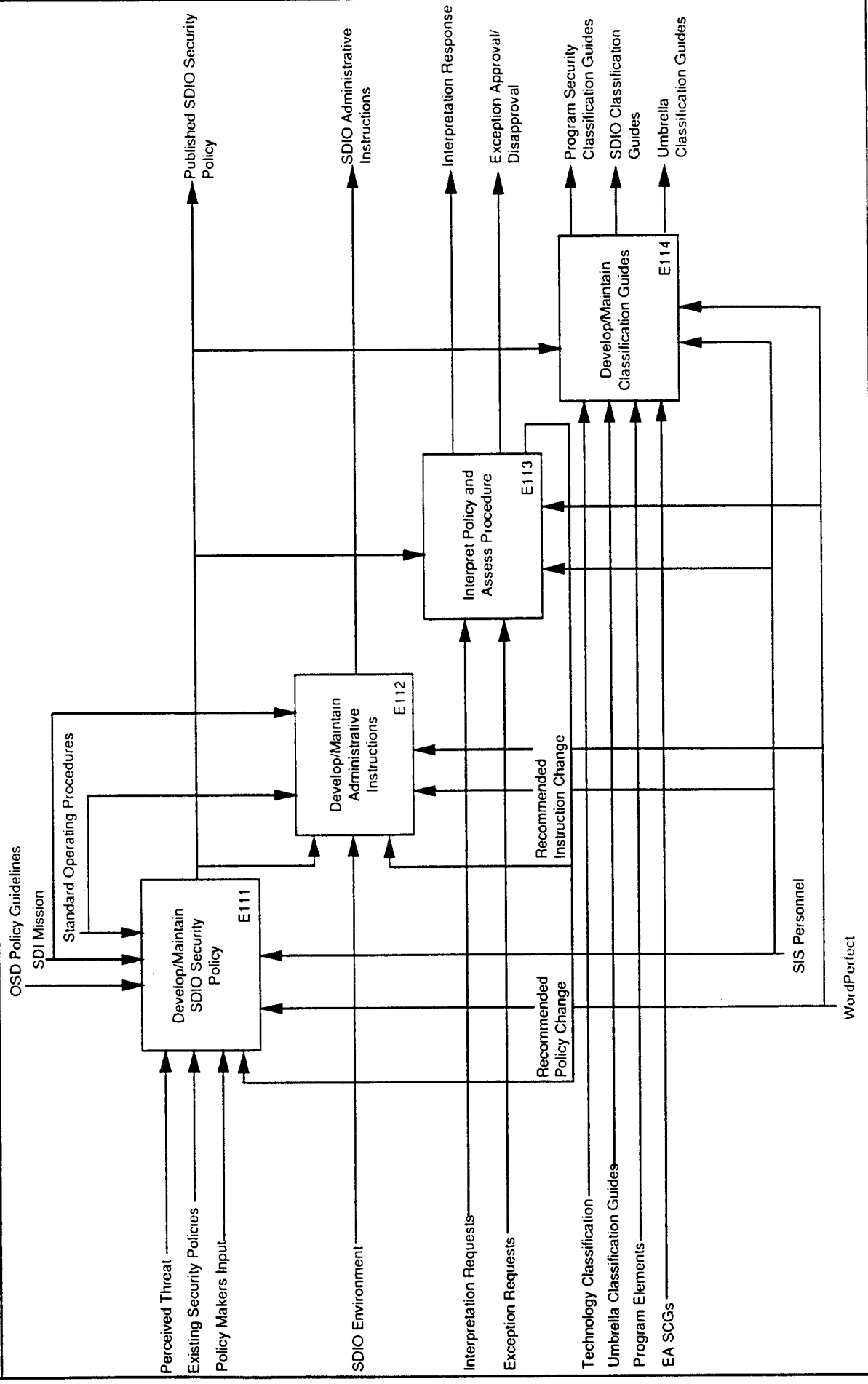

WORDPerfect	TITLE: Develop Security Guidelines	NUMBER
NODE: E11		

E12 - PERFORM ONGOING SECURITY OPERATIONS

E121 - COORDINATE SECURITY ACTIVITIES INTRA-SDIO AND INTER-SDIO AND OTHER AGENCIES

This activity is not developed for this model.

E122 - MAINTAIN LOCATOR DATA BASE

This activity is not developed for this model.

E123 - PROCESS VISIT LETTERS

This activity is not developed for this model.

E124 - MAINTAIN ACCESS CONTROL

This activity is not developed for this model.

E125 - REVIEW/APPROVE DOCUMENT CLASSIFICATION

This includes obtaining a completed document, submitting it to the review process, receiving comments, and issuing approval of the document's classification.

DEPICTION: AS-IS	AUTHOR: Nicholas Petruzzi PROJECT: Electronic Document Management	DATE: REV:	X WORKING FINAL	SECURITY POC: LiCol Peavey Mr. Brushwood	CONTEXT: <input type="checkbox"/> <input checked="" type="checkbox"/> <input type="checkbox"/>
---------------------	--	---------------	-----------------------	--	---

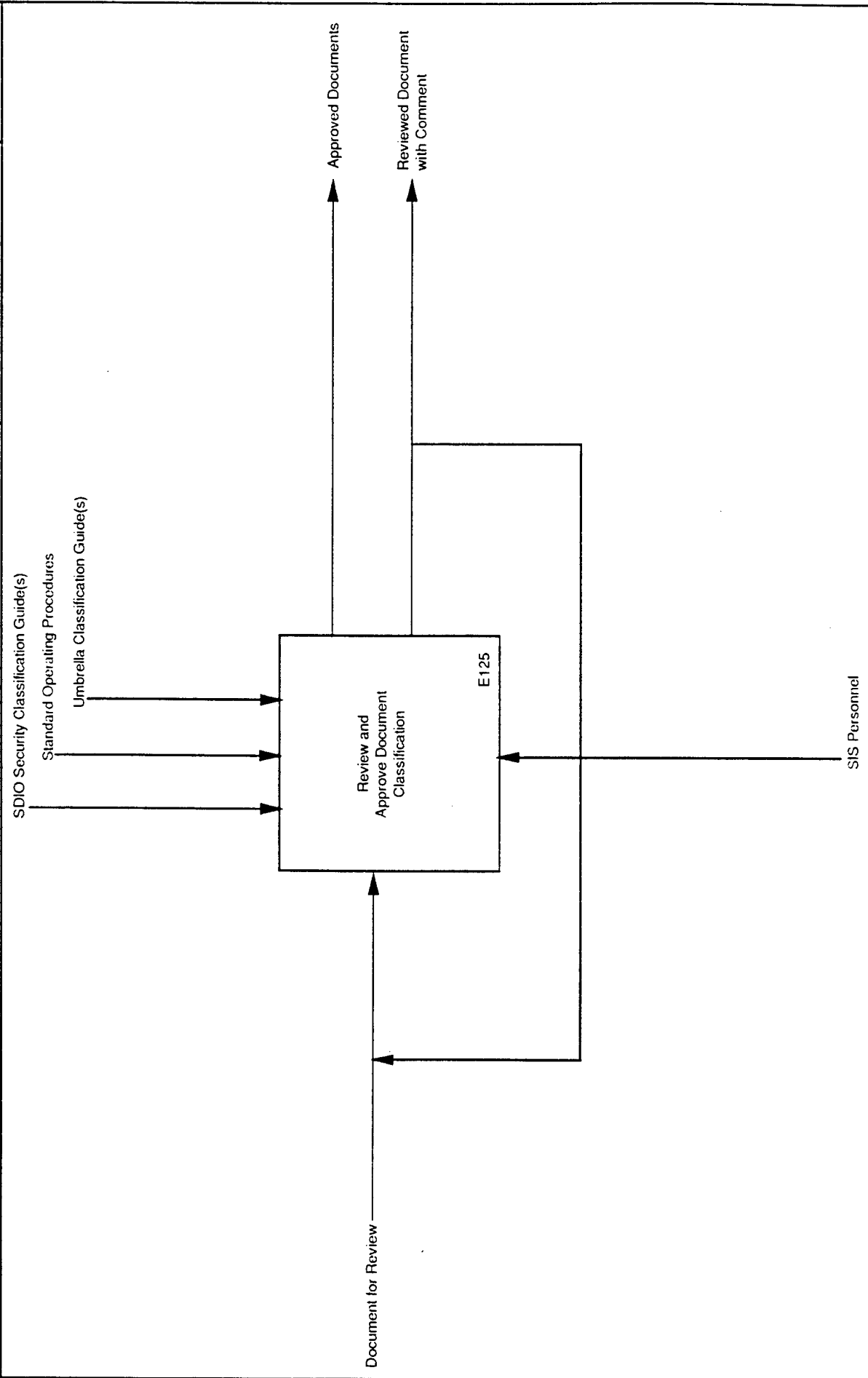

NODE E12	TITLE Perform Ongoing Security Operations	NUMBER:
-------------	--	---------

F. Cost Estimation Using the Cost Analysis Requirement Documents (CARDS)

The Cost Estimating and Analysis Division (POE) of Program Operations is responsible for directing the development of cost estimates based on the Cost Analysis Requirement Document(s) (CARD(s)) and for overseeing the overall process. The element program managers and the appropriate Services are responsible for developing one or more CARDS for each program element. CARDS are prepared for all the baselined Phase 1 elements, conceptual elements, and Phase 1 follow-on elements.

The CARDS "As Is" Node Tree depicts the overall activities followed to develop and maintain the CARD(s).

A request for a CARD starts the CARD development process and may be caused by a scheduled SDB or DAB. A lock-in date is determined and all requested CARDS must be as of the predetermined date.

# CARD(S) NODE TREE (AS-IS ENVIRONMENT)

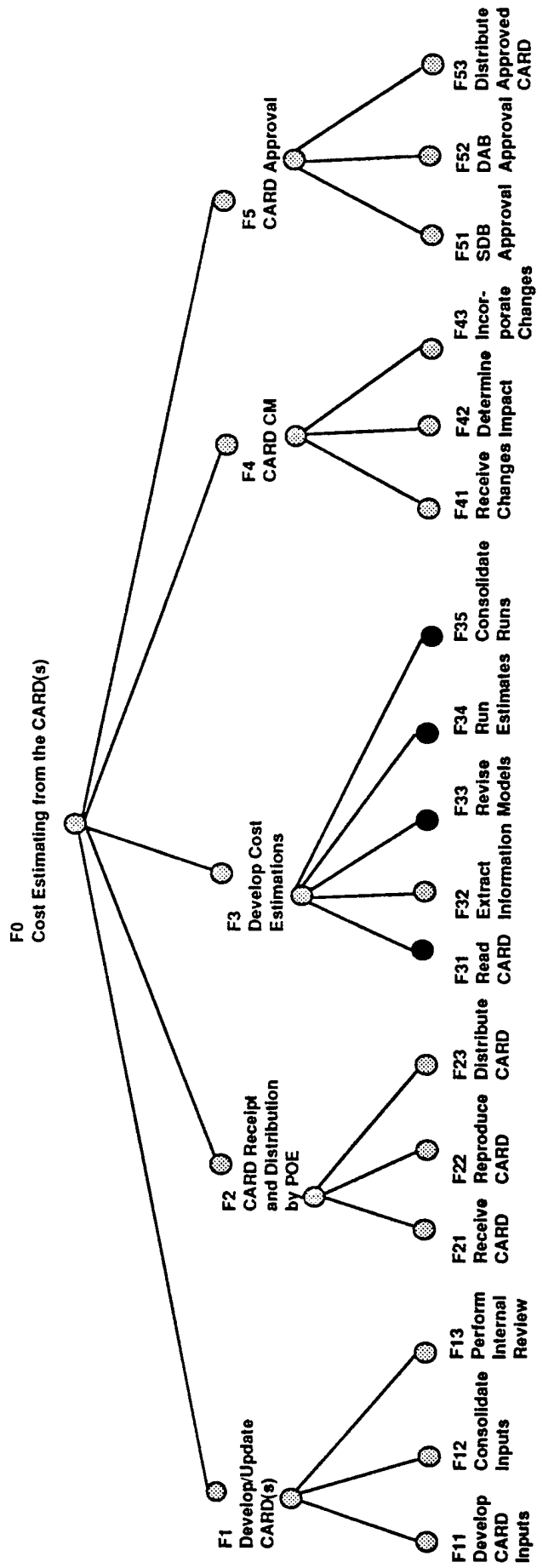

● = OUTSIDE OF PROGRAM SCOPE  
 ● = POTENTIALLY WITHIN PROGRAM SCOPE

IDEF

## COST ESTIMATION USING THE CARD "AS IS" ACTIVITY MODEL

- F0 - This is the highest level of the Cost Estimating from the CARD Activity Model. An overall picture of the activities is described.

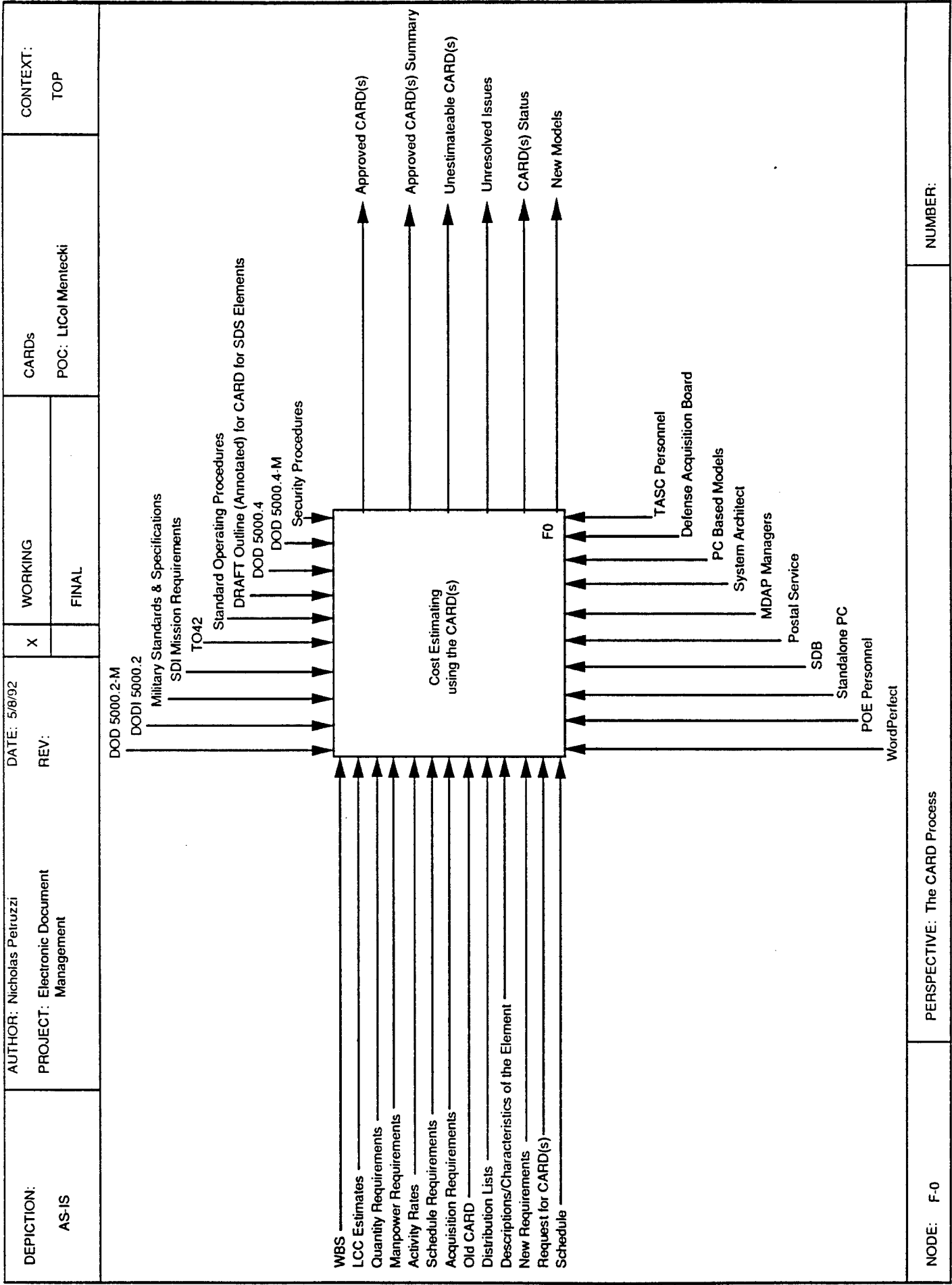

F0 - CARD ESTIMATION USING THE CARD

F1 - CARD DEVELOPMENT/UPDATE

CARDS are developed to facilitate the identification of operational and performance parameters and technical issues that could have a significant cost impact on the SDS element and should be addressed in detail by cost analysts. The information provided in the CARD should be limited to the data necessary for cost estimation.

F2 - CARD RECEIPT AND DISTRIBUTION

The CARDS are delivered to SDIO/POE for reproduction and pre-determined distribution.

F3 - DEVELOP COST ESTIMATES

The CARD is used as input in developing three cost estimates using computer models. CARDS that are in their infancy may be deemed unestimatable. The information from the cost estimates may produce issues.

F4 - CARD CONFIGURATION MANAGEMENT

As changes to the CARD are developed based on the outcome of the cost estimates, they are delivered to POE where an impact assessment is performed. Changes are incorporated and change pages distributed.

F5 - CARD APPROVAL

The CARD and its summary are presented to the SDB for approval.

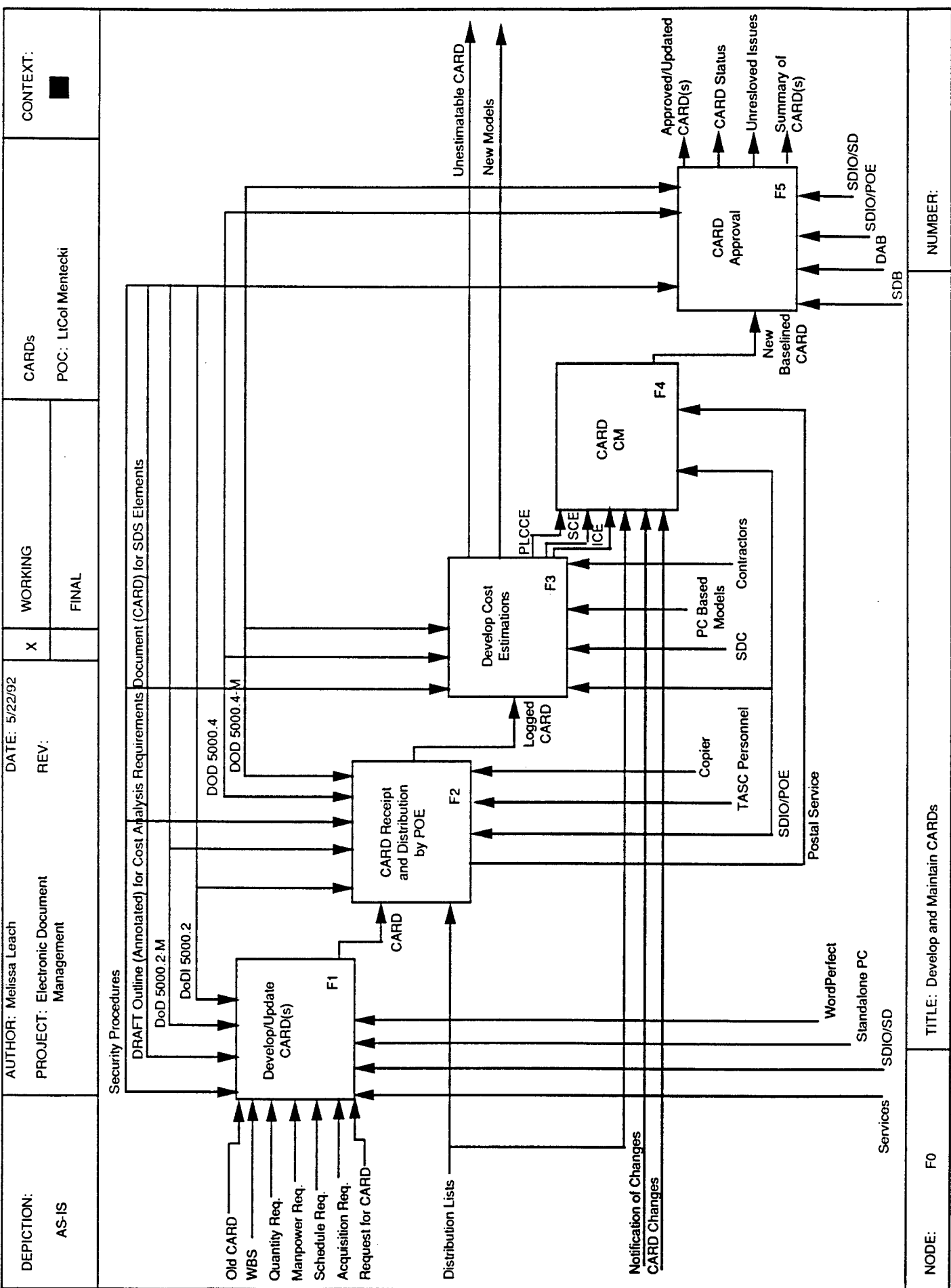

DEPICTION: AS-IS  
 AUTHOR: Melissa Leach  
 PROJECT: Electronic Document Management  
 DATE: 5/22/92  
 REV:  
 WORKING  
 X  
 FINAL  
 CARDS  
 POC: LtCol Mentecki  
 CONTEXT: ■

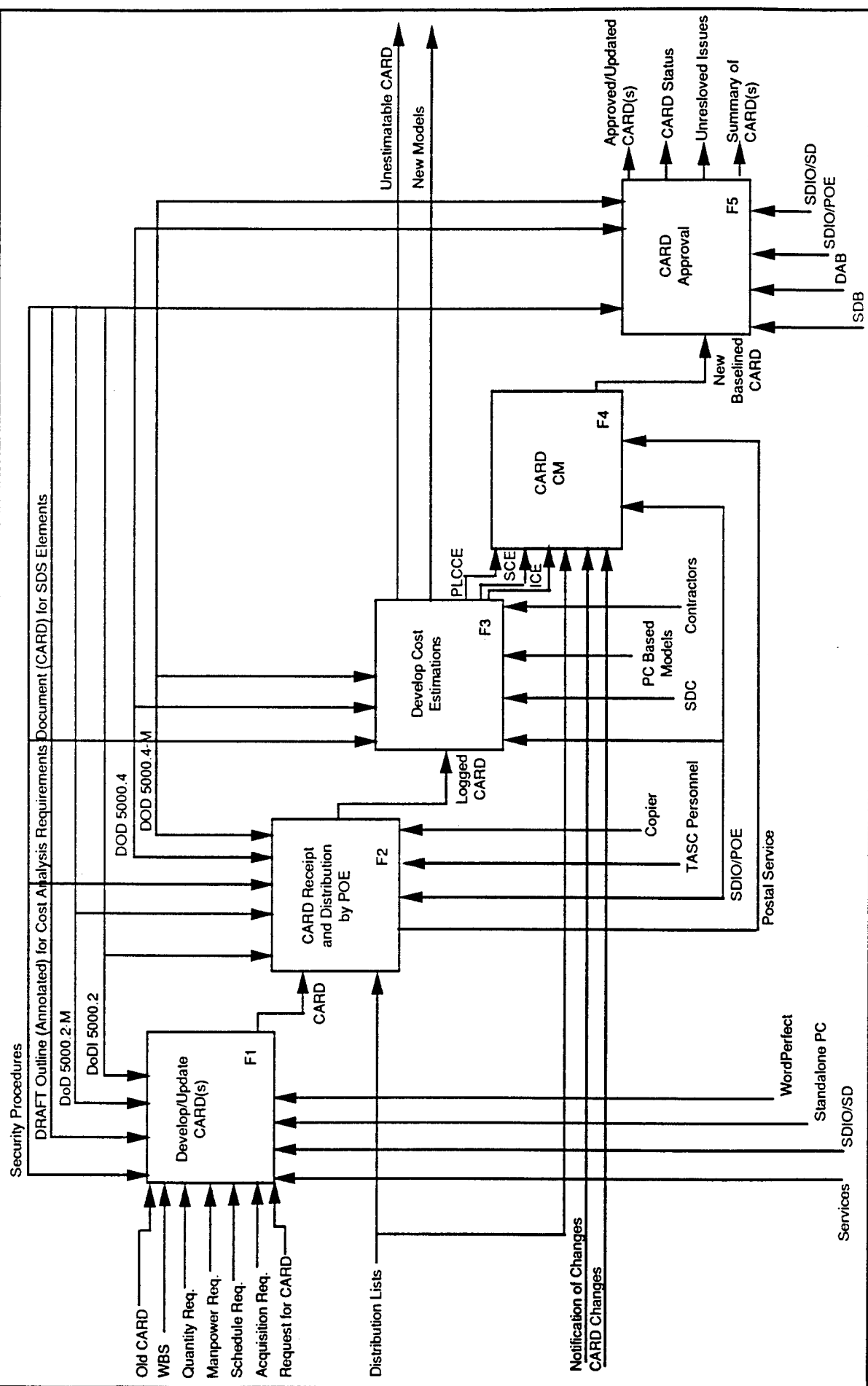

NODE: F0  
 TITLE: Develop and Maintain CARDS  
 NUMBER:

F1 - DEVELOP CARD(S)

F11 - PREPARE CARD(S) FOR EACH ELEMENT

Typically, one CARD is prepared per element and each MDAP produces a system CARD. The Services, along with SDIO/SD, develop the CARD.

F12 - CONSOLIDATE INPUTS

Inputs from various sources are consolidated into the CARD using the SDIO/POE prescribed CARD format.

F13 - PERFORM INTERNAL REVIEW

Most CARDS are classified at the Secret Level. When the CARDS are completed in draft form, they will be formally controlled as Secret documents. In addition, as the CARDS are being developed, all classified information incorporated in them will be strictly controlled in accordance with DOD regulations.

F2 - CARD RECEIPT AND DISTRIBUTION

F21 - RECEIVE CARD

The CARD is delivered by SD in hard copy to SDIO/POE where it is logged in.

F22 - REPRODUCE CARD

The document is sent to TASC under TO42 and reproduced.

F23 - DISTRIBUTE CARD

The CARD is mailed to members on the distribution list. This list of recipients remains the same for all CARDS.

DEPICTION: AS-IS	AUTHOR: Melissa Leach	DATE: 5/22/92	WORKING	CARDS	CONTEXT:
	PROJECT: Electronic Document Management	REV:	FINAL		

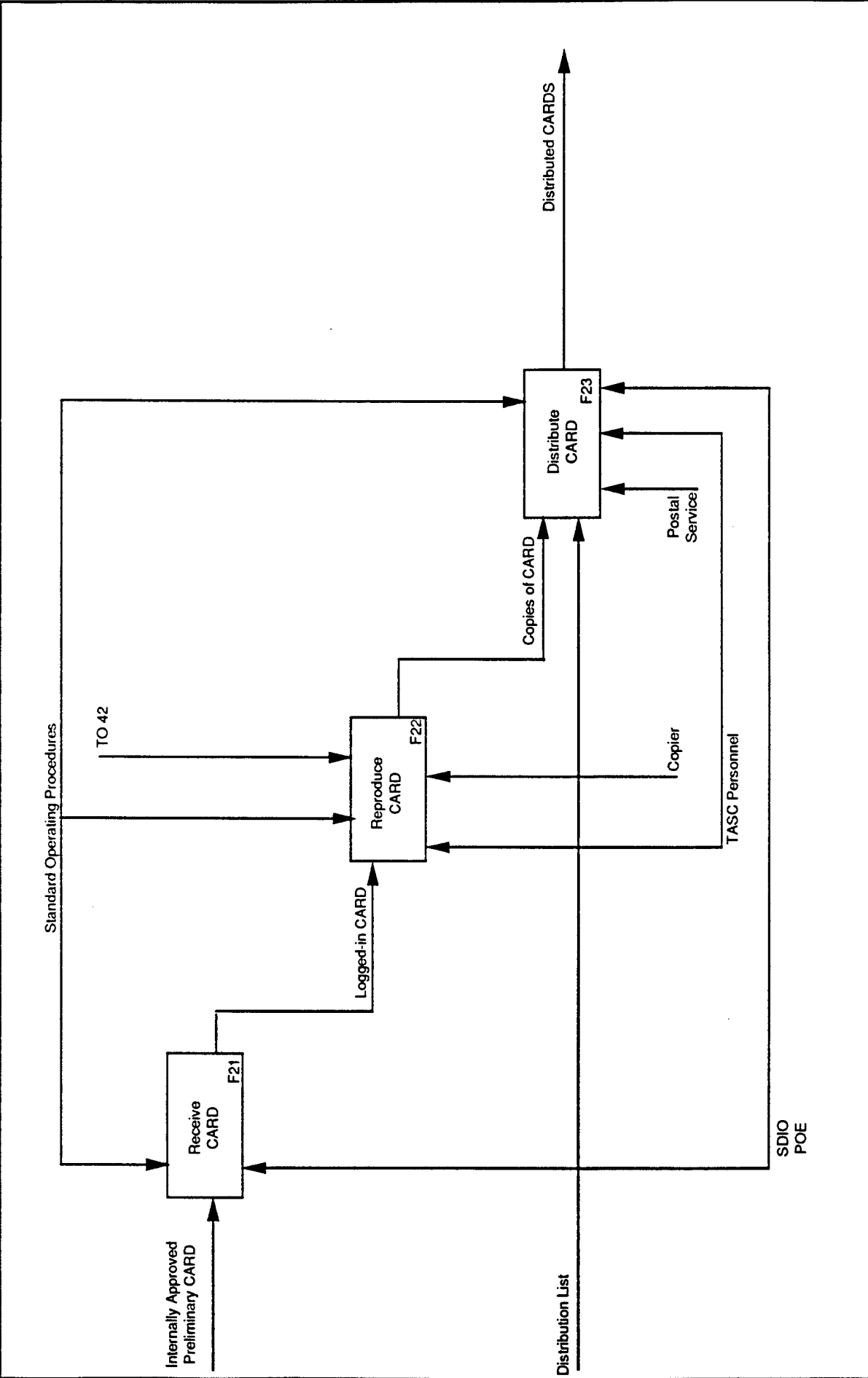

NOTE:	NUMBER:
-------	---------

F3 - DEVELOP COST ESTIMATES

There are 3 cost estimates prepared from the CARD; the program life cycle cost estimate (PLCCE), the independent cost estimate (ICE), and the SDIO cost estimate (SCE). The SCE is prepared by SDIO/POE.

F31 - READ CARD

The CARD is read to determine if there is enough information present to develop cost estimates. If there is not sufficient information, they will return comments to POE.

F32 - EXTRACT INFORMATION

The data that is pertinent to the cost estimate is extracted from the document and loaded into a PC.

F33 - REVISE MODELS

Based on the changes and additions to the CARD from the previous version, the PC based model is revised.

F34 - RUN ESTIMATES

The models may be used several times to produce adequate results. Communication may take place between the estimators and the CARD originators.

F35 - CONSOLIDATE RUNS

The SCE, ICE, and PLCCE runs are consolidated into one cost estimate by POE. Issues between the PLCCE/ICE and the SCE may either be resolved or forwarded to the SDB for resolution.

F4 - CARD CONFIGURATION MANAGEMENT

F41 - RECEIVE CHANGES

As requirements and schedules change, change pages are developed by the CARD originator and delivered to POE.

F42 - DETERMINE IMPACT

POE will review the entire CARD in light of changes submitted by the CARD originator. If additional changes to the CARD are required due to the original change, POE will request the additional changes to the appropriate element manager.

F43 - INCORPORATE CHANGES

Once the changes are complete, the appropriate change pages are inserted into the document. Red lining identifies this as a change.

F44 - DISTRIBUTE CHANGES

The change pages must be reproduced and distributed to the cost estimators so the estimates can be updated. This is currently accomplished through the mail service without prior notification of changes to the recipients.

F5 - CARD APPROVAL

F51 - SDB APPROVAL

Briefings are presented to the SDB by SC and POE. The SD briefing consists of the description/characteristics, schedule, TY \$s in millions and issues; while the POE briefs the cost details. The SDB hears and resolves issues from both SD and POE.

F52 - DAB

The DAB meets at least annually where a summary of the CARD(s) is presented and approved. CARD(s) must receive prior approval from the SDB before being presented to the DAB.

F53 - DISTRIBUTION

Once the CARD is approved, it is distributed en masse, to be used as input to Service cost estimates and other applicable documents.