

REPORT DOCUMENTATION PAGE

Form Approved OMB No. 0704-0188

Public reporting burden for this collection of information is estimated to average 1 hour per response, including the time for reviewing instructions, searching existing data sources, gathering and maintaining the data needed, and completing and reviewing the collection of information. Send comments regarding this burden estimate or any other aspect of this collection of information, including suggestions for reducing this burden to Washington Headquarters Services, Directorate for Information Operations and Reports, 1215 Jefferson Davis Highway, Suite 1204, Arlington, VA 22202-4302, and to the Office of Management and Budget, Paperwork Reduction Project (0704-0188), Washington, DC 20503.

1. AGENCY USE ONLY (Leave blank)		2. REPORT DATE 1995	3. REPORT TYPE AND DATES COVERED Final Report	
4. TITLE AND SUBTITLE <i>The Study of Problems of STRIKERS effect ON A Composite, Liquid-reinforced Structure</i>			5. FUNDING NUMBERS F6170894W0786	
6. AUTHOR(S) Prof. Grigori Tcherniavski				
7. PERFORMING ORGANIZATION NAME(S) AND ADDRESS(ES) Russian Academy of Sciences 84/32 Orifsoyuznaya Ulitsa Moscow 117810 Russia			8. PERFORMING ORGANIZATION REPORT NUMBER N/A	
9. SPONSORING/MONITORING AGENCY NAME(S) AND ADDRESS(ES) EOARD PSC 802 BOX 14 FPO 09499-0200			10. SPONSORING/MONITORING AGENCY REPORT NUMBER SPC 94-4093	
11. SUPPLEMENTARY NOTES				
12a. DISTRIBUTION/AVAILABILITY STATEMENT Approved for public release; distribution is unlimited.			12b. DISTRIBUTION CODE A	
13. ABSTRACT (Maximum 200 words) This report results from a contract tasking Russian Academy of Sciences as follows: Construct a set of theoretical models to simulate the destruction of reinforced designs of composite structures.				
14. SUBJECT TERMS Nil			15. NUMBER OF PAGES 54	
			16. PRICE CODE N/A	
17. SECURITY CLASSIFICATION OF REPORT UNCLASSIFIED	18. SECURITY CLASSIFICATION OF THIS PAGE UNCLASSIFIED	19. SECURITY CLASSIFICATION OF ABSTRACT UNCLASSIFIED	20. LIMITATION OF ABSTRACT UL	

19980303 117

RUSSIAN ACADEMY OF SCIENCES
CENTER FOR PROGRAM STUDIES

"Approve"

Head of work, RAS

Corresponding Member

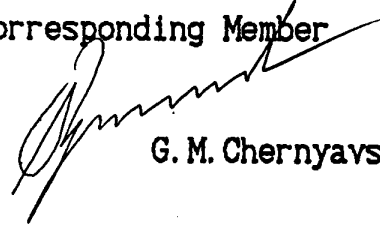

G. M. Chernyavskiy

Report

on fulfillment of research work

"The study of problems of strikers effect on
a composite, liquid-reinforced structure"

DTIC QUALITY INSPECTED 3

Moscow

1995

TABLE OF CONTENTS

1. Statement of the problem and the state of the object under study	3
2. Comprehensive analysis of the object under study	12
3. Development of analytic methods for evaluation of strikers interaction with objects under space environment conditions in the wide range of masses and velocities	20
4. Approaches to estimating post-barrier effect of a striker	42

THE STUDY OF PROBLEMS OF STRIKERS EFFECT ON A COMPOSITE,
LIQUID-REINFORCED STRUCTURE

1. STATEMENT OF THE PROBLEM AND THE STATE OF THE OBJECT
UNDER STUDY

1.1. Statement of the problem

With developing space technology the problem of conserving the integrity of objects (satellites of various designations, manned spacecraft, etc.) as well as their components (fuel tanks, for example) arose. This problem is caused by an effect of meteors and technogeneous particles flying at velocities of some tens kilometers per second. By technogeneous particles are meant here various bodies occurred to be in space as a result of human activity.

This paper outlines the principles of construction of a technique for substantiation of protection degree for one of 50 components, which represents a cylindric tank with liquid, fixed inside the vehicle by metal braces. The SO body is made of composite material.

The solution of this problem includes:

1. Substantiation and choice of a list of notions, definitions and degrees of protection for space objects and their components, as well as partial and generalized criteria for estimation of degrees of such spacecraft protection against impacts of meteors and technogeneous particles.

2. Analysis of space object with the purpose of developing its mathematic model.

3. Development of analytic methods and models of striker interaction with object walls made of composite materials within a wide range of impact velocities and conditions, for various pairs of materials and various shapes of strikers. This requires the development of a physical interaction model and substantiation of partial and generalized criteria for estimating strikers effect on objects walls.

4. Development of models for studying the combined action of several destroying factors arising in the process of high-velocity interaction of striker with an object wall (penetration, inflaming action, generation of the field of secondary ejections, aero- and hydroshock, etc.).

Besides, the solution of these problems requires a great amount of initial data, which can be obtained by carrying out independent investigations. A significant difficulty is probably met in obtaining the data related to parameters of the field of meteors and technogeneous particles: their flux density, the distribution of particles' trajectory parameters, the mass and velocity distributions, etc. Besides, the time variation of this flux must be known.

Many initial data can be obtained only experimentally. In this case there arise problems of accelerating the bodies of even small mass (1-2 g) up to required velocities, and the installations for accelerating heavy bodies (of mass up to 1 kg) do not exist at all. Such heavy bodies can be accelerated

up to 3.5 to 4 km/s only. This requires, however, preliminary simulation for selecting parameters of such a device, since this allows, to some extent, to form a striker (simulating technogeneous particles) of the given shape.

The problem of interpreting the obtained results to space environment conditions meets about the same difficulties.

In spite of a complexity of the stated problem, some principles of its solution will be considered in subsequent paragraphs and Sections.

1.2. State of the object to be studied

The problems of estimating the ground objects protection against the effect of man-made strikers (bullets, splinters, etc.) have been dealt with earlier. However, specific features of SO design and operation conditions do not allow to apply them for solving the problem stated. Besides, the velocities of striker collision with a ground object essentially differ from striker/SO collision velocities. As a result, the striker/barrier interaction mechanism and the consequences of this interaction will be quite different and, hence, all models for solution of protection problem will be of principally different character.

The high-velocity interaction of strikers with metal barriers (semi-infinite, finite and spaced ones) has been widely studied, and there are some results at impact velocities up to 8 km/s and striker masses up to 2-3 g. These results,

however, can not be utilized by two reasons: the body is made of composite material and the mass of strikers (technogeneous particles) can reach hundreds grams. One of features is also the fact, that the velocity of these particles interaction with a barrier may vary virtually from zero up to some tens of kilometers per second. One should note that, as the practice shows, composite materials are quite rarely applied in their pure form. More frequently, multy-functional cover is deposited on the outer surface of objects, and the inner surface is covered with a material that protects a wall from the action of liquid contained inside (fuel or oxidizer, for example). Both these covers, as compared to composite materials (textolytes, fiber glasses, carbo-plastics, organic plastics, etc.), which are composed of a matrix (usually some resins, graphite, etc.) and a filler (usually some cloths), have amorphous structure and appropriate properties. Due to this fact the striker/barrier interaction has complicated character stipulated by a multy-layer nature of object's wall and diversity of these layers' material characteristics. Besides, some metal units may be built-in into object's wall, which also has an effect on the model of striker penetration into this barrier as well as on the general model of estimation of object's protective ability.

Thus, as the practice shows, the most widely spreaded designs of barriers containing composite material layers (non-metal materials) are:

- * one-layer plates made of composites (or plastic

masses);

* multy-layer plates made of composites and plastic masses);

* multy-layer plates made of composites, plastic masses and any metal;

* multy-layer plates made of composites and any metal.

In principle, the other combinations of materials in barriers may also be applied, but those mentioned above are most widely spreaded, and some individual experiments have been carried out for estimating their impact resistance (the determination of character and scope of destructions after strikers impact on a barrier under specified encounter conditions).

The studies of high-velocity interaction of strikers with barriers made of non-metal materials drastically differ from studies of striker/metal barrier interaction.

First, a great diversity of barrier designs and non-metal materials are applied in a rather small quantity of experiments. This does not allow to process experimental data statistically and, accordingly, to find any dependences (regularities) between these data and conditions of strikers interaction with barriers and characteristics of these barriers.

Second, all these studies have application character, i. e. they have been carried out for some specific structure. Therefore, there are, actually, no model on physics of striker interaction with not only multi-layer, but even one-layer

barrier.

Third, all experiments were performed with the purpose of determining the resistance of barriers. The strikers used in these experiments were made of non-metal materials, such as calcined clay, ceramics, quartzite and glass. Besides, special strikers made of a mixture of metal and non-metal powders have been applied in some investigations. The shapes of strikers were a sphere, a cube and a cylinder.

Fourth, to estimate the results of striker/barrier interaction a rather great number of partial criteria is applied (such as crater size, concavity size, puncture size, visible and invisible areas and volumes of barrier material destruction, etc.), which can hardly be determined both theoretically and experimentally.

Fifth, the striker/barrier encounter conditions (encounter angle - the angle between the striker velocity vector and either a tangent plane at the given point of a barrier (Q_c) or a normal to the surface at the given point of a barrier (Q_n), the encounter velocity) had a small range of variation (the velocity, for example, - not more than 2000 m/s, and encounter angles (for the first determination case) - not more than 10° , as a rule. Some experiments have been carried out, however, at greater angles as well.

Unfortunately, it was impossible to combine all investigations performed into a single scheme. We shall present here only some examples of experiments, in which barrier materials were identical to object's wall materials.

In our experiments the barriers made of fiber glass and carbo-plastic 3.5 to 4.5 mm thick were loaded by strikers, which represented balls made of calcined clay of mass (m_s) 6.0 to 7.0g and 40 to 43 g. The striker-barrier encounter velocities were 600 to 800 m/s, the encounter angles were 15 to 20° from the barrier surface.

The partial criteria for estimating the results of strikers effect on barriers were chosen as follows:

- * length, width and depth of a hollow;
- * length and width of cracking and stratification of barrier material;
- * dimensions of axes of the oval through hole;
- * areas of each of above-mentioned destructions, S.

The results of these investigations are summarized in Table 1.1. Fig. 1.1 presents the dependences of the area of visible cracking and stratification S_{cr} and areas of through holes S_h on a striker mass.

Table 1.1

Partial destruction criterion name	6.0-6.4 g striker		40.0-42.6 g striker	
	fiber glass	carbo plastic	fiber glass	carbo plastic
Hollow length,width and depth, mm	25x40x3			
Length and width of cracking and stratification of barrier material, mm	100x0.5	120x130	30x50	200x300
Axes of an oval through hole, mm		0.5x110	20x30	16x200

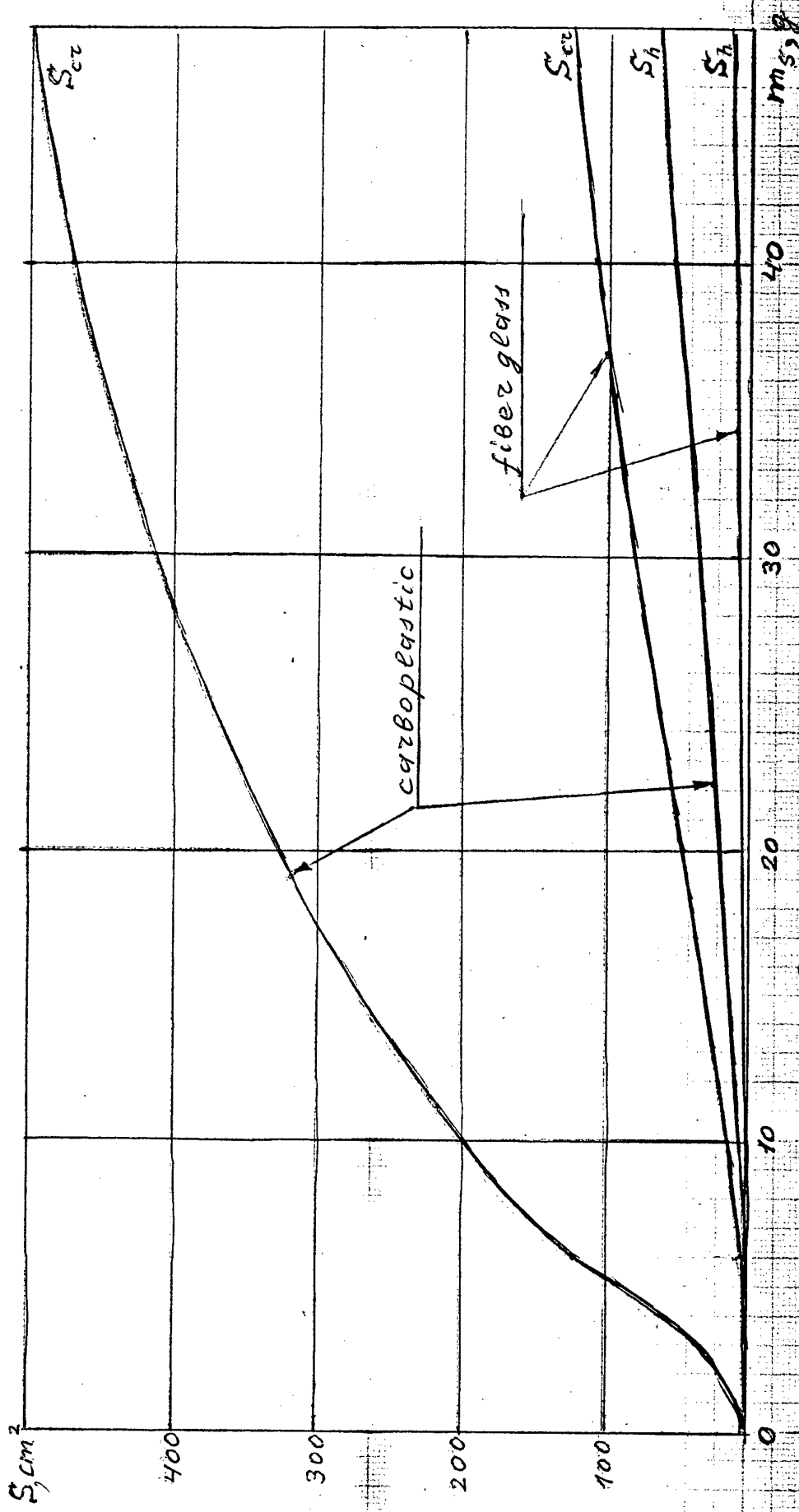

Figure 1.1

One should pay attention to the fact, that all above criteria relate to visible destructions of barrier only. In fact, however, when strikers interact with barriers made of composites, there arise also invisible destructions in form of stratifications and cracks.

For estimating the scope or area of internal stratifications the authors have developed a new method of non-destructive control, that represents a combination of two well-known techniques: penetrating substances and X-ray analysis. The new method utilizes, instead of a colour penetrant, the solution of substance possessing both high wetting and penetrating properties (low surface tension), and high X-ray contrast. The second method of non-destructive control is used in its conventional version.

The X-ray-contrast penetrant is inserted into a stratification, which is visualized on a roentgenogram as clarified sections.

The use of this nondestructive control technique is exemplified by experiments on estimating the impact resistance of organoplastic barriers loaded by quartzite strikers at impact velocities of 800 to 900 m/s and encounter angle of 10° from the barrier surface.

The destructions were represented by hollows 60-80 mm long, 25-30 mm wide and 4-6 mm deep. The area of visible destructions was 1600 to 1800 mm^2 .

The application of the above -mentioned nondestructive control technique allowed to estimate the area of internal

stratifications and cracks, which occurred to be 10 to 20 times larger, than the area of visible ones. Besides, a great amount of invisible stratifications inside a barrier was found, which were comparable in size with visible ones. This fact is very important for practice, since many composite structures are carrying ones, and the disregard of internal stratifications may lead to serious consequences in exploiting such structures.

In addition, the results of these investigations allow to draw very important conclusions.

In a multiple, successive loading of a barrier by strikers the effect of "damage accumulation" arises. This effect lies in the fact, that the volume (area) of invisible destructions, caused by successive action of two strikers on a barrier, is essentially higher, than the sum of volumes of destructions caused by individual strikers. So, in our investigations this effect was observed on stratifications between the impact points equal to 2 to 10 calibers of strikers. In this case the subsequent impact may cause 2 to 3-fold increase of destruction area in a previous impact zone.

In conclusion, one should note that the experiments we have performed did not allow to find any dependences between barrier characteristics, striker parameters and conditions of this striker encounter with a barrier. Therefore, even if there exist some models for estimating the degree of object protection, a great amount of experimental studies are needed for obtaining the initial data required for solving this problem.

2. COMPREHENSIVE ANALYSIS OF THE OBJECT UNDER STUDY

For estimating the object resistance to the action of any technogeneous particles and meteors, some quantitative criterion is required, that will be called the resistance factor. The numerical value of this factor must characterize the degree of object's stability to fulfillment of its specific functions under an effect of technogeneous particles. Since the main result of technogeneous particles and meteors action is the infliction of some damage to an object, the numerical value of resistance factor must in any way characterize the scope of damage inflicted to an object.

The issues of physical sense of a resistance factor and specific sense of a number, characterizing the scope of damage inflicted to an object, can be resolved by analyzing the essence of destructions inflicted to an object. The degree of object's injuries will characterize the measure of damage it suffered. At some degree of injuries the object is brought into the state, when it becomes unable to operate and fulfill its designated functions. Obviously, in this case the probability of object's failure due to particles effect, accepted as a resistance factor, will represent the probability of the fact, that some quite certain injuries will be inflicted to an object.

The list of destructing injuries is mainly defined by object's designated tasks. If, for instance, one determines the conditions, in which the object under study is instantaneously

brought into the failure state, then in estimating the destructive effect of particles and in classifying the injuries only those ones should be taken into account, which result in immediate cessation of object's designated functioning, and all rest injuries should be attributed to non-destructive ones. In the case, if one determines the conditions, in which the object under study will cease its designated functioning after a time not longer than specified one, then in estimating the destructive effect of impacted particles and in classifying the injuries one should attribute the injuries, resulting in object's failure for specified time, to be destructive ones.

Thus, in solving the problem of estimating object's resistance to technogeneous particles' effect, one should analyze object's structure and the character of operation of each of its aggregates and find in object's structure such aggregates and components whose destruction will cause the failure of an object as a whole.

In determining the probability of object's injury by technogeneous particles one should first determine, what is the particular injuring effect of a technogeneous particle striking an object. The available data allow to consider the technogeneous particles to possess the following types of injuring effects:

- * puncturing effect;
- * inflaming effect;
- * initiating effect;
- * aero- and hydroshock.

The puncturing effect is the most typical and, at the same time, the most versatile form of injuring effect. It includes such types of injuries, as various mechanical damages of injured components: propulsion units, various drives, breaking of control braces and cables, pipelines for technological liquids and gases, etc. The character and scope of mechanical damage, inflicted to various injured components, are defined, first of all, by the barrier thickness that is punctured by a technogeneous particle. In some cases for estimating the degree of injury one must know the hollow area.

The inflaming effect of technogeneous particles reveals in affecting the injured components, whose structure contains various highly inflammable elements in the presence of an oxidizer. The main cause of igniting the combustibles is the presence of a metal shell in object's structure. When the shell is punctured, a lot of small incandescent particles are generated - some kind of a "torch" of incandescent dispersed metal, that can lead to inflammation and subsequent combustion with some probability.

The initiating effect of technogeneous particles reveals in their capability to initiate explosive transformations in thermodynamic systems (in special fuels, mixtures, etc.) as a result of shock wave generation in a system due to particle impact.

The aero- and hydroshock phenomenon arises, when high-velocity particles are moving in injured components filled with gases or liquids. The motion of particles in a gaseous or

liquid medium causes shock waves, which may result in vast destructions of injured components and in the object failure.

Thus, in a comprehensive analysis of the object under study one should find injured components and determine the type of technogeneous particles' injuring effect on each of these components. One should note that the object under study may comprise injurable components, which must be failed jointly to stop functioning of an object. These components are treated otherwise as injurable combinations of aggregates. Examples of injurable combinations are various backup aggregates (backup control system, backup pipelines, etc.).

The presence of injurable combinations in the object structure testifies to the appearance of damage accumulation phenomenon in the object. This phenomenon may be taken into account by means of logical vulnerability functions, which can be written in the general case as

$$A = \sum_{i=1}^n a_i + \sum_{j=1}^m \sum_{i=1}^{k_j} a_{ij}$$

In this formula A, a_i and a_{ij} symbols denote the following events:

- A - object functioning cessation;
- a_i - failure of the i -th injured component that leads to injury of the object under study as a whole;
- a_{ij} - failure of the i -th injured component in the j -th injurable combination;
- n - the number of injured components, the failure of one

of which (at least) results in the injury of an object as a whole;

m - the number of injurable combinations;

k_j - the number of injured components in the j -th combination.

One should note that the number of elementary events a_i and a_{ij} will be much higher, that the number of injured components. This is due to the fact, that some aggregates may be injured by different injuring factors.

As noted above, the list of injuring damages and injured components is defined by object's designated tasks. Obviously, under an effect of technogeneous particles the object may occur to be in various states of working capacity. In this connection, it seems expedient to introduce some ratings of object's working capacity loss degree in accordance with its designation. Of interest is the following rating of damage inflicted to an object (for example, for military space objects in the emergency period):

* immediate cessation of object functioning and bringing it into the state of impossibility of its further utilization (destruction, explosion, etc.);

* object functioning cessation and bringing it into the state of impossibility of its further utilization during the time not greater than t_1 . This time is defined either by the time of solution of one of object's functional or by the time of fulfillment of emergency operations;

* refusal from the fulfillment of object's functional

tasks during the time not shorter than specified t_2 .

Obviously, the first and second ratings do not envisage restoration of an object, and the third one, on the opposite, envisages restoring works. We call these ratings the injury type and assign them letter designations (for example, I - instantaneous, S - slowed, D - durable). This will imply, that the event and injury of type "S" will include the event and injury of type "I", and the event and injury of type "D" will include object's injury events of first two types.

The above object's injury degree ratings require injured components' classification according to injury type. In this case the same object's aggregates may be injured in different manner under different conditions, that requires obtaining a proper logical vulnerability function for each type of injury.

After separating and classifying injured components according to injuring effect type, degree of influence on object functioning as well as according to injury type, the stage of mathematic description of an object under study commences. It may include:

- * either determination or specifying the frame of reference (coordinate system), in which the position of all injured components is defined; as a rule, the rectangular, object-centered coordinate system is selected;

- * mathematic description of each of injured components. As a rule, actually injured components are represented in form of rectangular parallelepipeds, more rarely - in form of cylinders, cones, prisms, etc.;

* specifying of coordinates of injured components evaluated and their orientation with respect to the coordinate system chosen;

* determination of a relative position of injured components and the conditions of their screening by other injured components, screens and non-injured aggregates (for the given type of injury);

* determination of vulnerability characteristics of injured components with respect to an action of technogeneous particles in accordance with applied techniques of estimating an injuring effect.

The components of the stage of mathematic description of an object under study may be updated in the development process depending on the level of knowledge in the investigated area, on the complicacy of applied techniques for estimating an injuring effect, on model assumptions, etc. So, for example, the choice of a coordinate system may be influenced by the character of motion of an object under study and its preferable orientation, by technogeneous particles' flux characteristics and, finally, by the object design itself. The vulnerability characteristics of injured components evaluated may change not only their physical meaning (depending on techniques applied), but also their magnitude. (For example, in calculating the resistance factor in accordance with the logical vulnerability function the whole face of an injured component should be used in calculations, whereas in calculating the viability factor without an account of injurable combinations some conventional

face area may be used in calculations; in so doing the injury of aggregates included in an injurable combination is supposed to be independent).

A preliminary analysis indicates, that the comprehensive analysis of an object under study should establish the following data:

- * coordinates of an injured component center;
- * injured component size;
- * area of an injured component's face from every direction;
- * minimums and maximum thicknesses of barriers screening an injured component;
- * generalized characteristics of thickness and spreading of barriers;
- * parameters characterizing the injured component's vulnerability to inflaming effect;
- * thickness of barriers screening explosive systems ;
- * experimental coefficients characterizing strength properties of a structure, materials, etc.

The final composition of initial data is determined from the results of estimating an injuring effect of technogeneous particles on various components and concordance of calculation technique with the results of experimental investigations.

3. DEVELOPMENT OF ANALYTIC METHODS FOR EVALUATION OF STRIKERS INTERACTION WITH OBJECTS UNDER SPACE ENVIRONMENT CONDITIONS IN THE WIDE RANGE OF MASSES AND VELOCITIES

The evaluation of the results of dynamical interaction of colliding bodies is a very topical problem. Its solution has attracted great attention in the recent time, which is defined by engineering practice requirements.

The complexity of mathematic description of a high-velocity impact is stipulated, first of all, by diversity of the final result. So, the following outcomes may take place in practice:

- * elastic impact;
- * erosion;
- * crater formation;
- * insertion (penetration to a particular depth);
- * puncture to extreme thickness;
- * through puncture.

The latest two cases are of practical interest from the viewpoint of injuring action evaluation. Here one should concretize, that by a through puncture is meant such an interaction of bodies, when the impacting body (a striker) forms the hole in a screen and still retains some velocity in the post-barrier space. In the case of puncture to extreme thickness this retaining velocity is zero, though the sealing of a screen (a shell) is infringed. For more certainty the metal barrier is supposed to be punctured, if the face surface

of a cork broken away in a screen reaches a rear surface of a screen.

From the viewpoint of viability of the object under study of practical interest are also the other results of collision, except the elastic impact. Indeed, even the erosion ablation of a screen mass, that is accumulated with time, may reach a critical value and, thus, lower its strength properties.

The above interaction results suppose, that the screen size (and, hence, the mass of an object under study) is large enough as compared to size and mass of impacting bodies (particles). Of course, in practice two colliding objects may have about the same size and masses. Obviously, their interaction may result in the change of their motion trajectories, as well as in the deformation or destruction of bodies. Conventionally, this case may be called "the collision of objects", which is not considered in this paper. The erosion destruction and crater formation phenomena are also disregarded here. Thus, the main attention is paid here to developing analytic techniques for evaluating the through puncture and puncture to extreme thickness. As to the process of body penetration into a screen as a barrier of semi-infinite thickness, this case is considered as a possible version of solution of an inverse problem, namely: to find such an extreme thickness h_{extr} of a barrier, which can still be punctured by a body having mass m_s and initial velocity v_s . The direct problem is reduced in this case to the determination of body velocity behind a screen after its puncturing, if the screen

thickness h , body mass m_s and initial impact velocity v_s are known.

The schematization of body/barrier collision phenomena and the description of accompanying processes depend, first of all, upon velocity v_s . In the velocity range of 0 to 2000 m/s takes place the mechanical destruction of a barrier, in which case the shear deformations prevail in metal barriers, and the puncture is terminated by breaking away a "cork" or "waste".

The character of destruction of non-metal barriers seems quite different outwardly. In particular, the striker, that encounters a barrier, made of composition material (such as carboplastics), at velocity $v_s = 500-1200$ m/s, breaks a narrow slit-like hole (the width-to-length ratio reaches $1/200$ and produces surficial material stratification of about the same configuration, but over a larger area. The oval-shaped hollows are formed in fiber glass barriers, the hollow size being much larger, than the diameter of striker (a ball). Besides, the material cracking takes place here over much larger (3 to 5 times) area of the same configuration. For both materials the configuration of hollows, stratification and cracking zones is determined by the position of filler filaments.

At velocities $v_s > 2000$ m/s huge pressures (of the order of 10^{10} Pa) arise on the area of body contact with a barrier. These pressures highly exceed the yield stress of a barrier and body materials. Hence, their interaction process may be considered as an insertion of a liquid metal spray (the spray length l_s equals the body length) into a liquid medium of

barrier. The hydrodynamic model of such a penetration was theoretically developed by Academician M. A. Lavrent'yev. Proceeding from the dependences, obtained in the theory of incompressible fluid hydrodynamics, he deduced a formula for determining the thickness h of armor punctured. It is called Lavrent'yev's formula and has a form:

$$h = l_s (\rho_s / \rho_b)^{1/2} \quad (3.1)$$

where l_s is the spray length;

ρ_s , ρ_b are spray and barrier densities, respectively.

Formula (3.1) underwent experimental checking. In particular, it was found, that at high velocities v_s , due to materials compressibility and spray material time lag after the spray operation, the actual thickness of a barrier punctured occurs to be slightly larger, than the h value determined by formula (3.1). This fact may be taken into account by introducing a correction, and formula (3.1) may be written as

$$h = l_s (\rho_s / \rho_b)^{1/2} + K(\rho_b v_s^2 / \sigma_{yb})^{1/3} \quad (3.2)$$

where K is the experimental factor;

σ_{yb} is the yield stress of barrier material.

The results of calculations, based on hydrodynamic theory of puncturing, show well coincidence with experimental data for metal materials with high density (steel, copper) and velocities of the order of 3000-8000 m/s. As to the

experimental data on using the hydrodynamic penetration model for non-metal (including composition) materials and the velocity range, where it is applicable, these issues deserve a special attention and investigation. So far the possibility of applying hydrodynamic penetration theory to non-metal materials is not proven yet.

As the impact velocity further increases, the impact pressure at the contact surface grows to such an extent, that barrier and body materials are heated up almost instantaneously to the temperatures, at which they are evaporated very rapidly and the vapour products are then expanded. In such case the character of barrier destruction may be modelled by the process of explosion of explosive's charge of equivalent mass on the barrier surface with forming a crater or a funnel. Indeed, the comparison of kinetic energy of the body having mass m_s with the energy of explosion of a charge of equivalent mass m_e gives rise to the following dependence:

$$m_e = K_d (m_s v_s^2 / 2V_w), \quad (3.3)$$

where V_w is the specific energy of explosive;

K_d is the factor characterizing the fraction of a body energy spent for barrier destruction; this factor has to be checked experimentally.

Assuming $v_s = 9000$ m/s , $v = 4.1 \times 10^6$ J/kg (trotyl) and $K_d = 0.5$, one finds from (3.3)

$$m_e = 5 m_s .$$

Thus, from the energy balance point of view the impact of bodies flying at velocities of about 9000 m/s is equivalent to the explosion of trotyl charge equal to 5 masses of a falling body, if only a half of body's kinetic energy is spent for barrier destruction in this case.

The consideration of explosive's charge explosion at the barrier surface as a model of impact process at hypersonic velocities allows to describe the craters (funnels) formation mechanism and to obtain formulae for determining their parameters. This process is under extensive studying presently, though the majority of published works concerns the consideration of crater formation at the earth surface (as well as in the hard rocks) at contact and over-surface explosions of nuclear charges and conventional explosives, as well as in forming the craters of meteorite origin. In such cases the barrier is supposed to be a semi-infinite one. As to the mechanism of crater formation in semi-infinite barriers, which represent a shell (screen) made of homogeneous (both metal and non-metal) or, all the more, of composition material, this problem needs further investigation. Both theoretical and experimental results may serve as a basis for developing the calculation models here. In this case a special attention should be paid to studying the process of puncturing thin and thick barriers at hypersonic velocities, which are accompanied by explosion-type phenomena.

Let us consider now in more detail some issues related to mathematical description of the body/object interaction process.

3.1. Interaction of bodies with planer barrier in the lower range of impact velocities

The lower velocity range covers the velocities of body encounter with barriers varying from 1500 to 2000 m/s, i.e. those velocities, at which the metal bodies collision processes are governed by the incompressible fluid hydrodynamics theory. Though a lot of works and a variety of calculational analytic dependences have been derived to this problem, it still remains rather topical so far. This is explained, first, by a versatility of engineering problems related to evaluation of injuring action and objects viability, and, second, by a high diversity of structural parameters and strength properties of both barrier's and impacting body's material.

Though in each particular case one usually manages to substantiate the calculation technique and to obtain analytic formulae establishing the relation between specified and unknown parameters, this problem can not still be completely solved by analytical technique only. This is due to the fact, that in the body/barrier interaction process, when the stages of body insertion, penetration and barrier puncturing are investigated, one must take into account the material strength increments, which are especially prominent at impact loading. In these cases one often applies, as a calculation parameter, the so-called "dynamical elastic limits" σ_{sa} or "dynamical yield limits" σ_{sd} , which for the majority of materials highly exceed the values of similar quantities obtained for statical loading. So, for hard

rocks the ratio of dynamical to statical elastic limits reaches the value of 10. For many metals the ratio of yield limits at dynamical and statical loading is 1.5 to 4.0 and more. For aluminum alloys, however, this ratio may be either higher or lower, than 1.

Of special interest is the question of variation of strength properties of composition materials, which are known to differ in the character of variation of matrix' and filler's material properties. By this reason the barrier material as a whole possesses anisotropic properties. This results, finally, in the incoincidence between the shapes of hollows, destruction and stratification zones and the shape of striker's maximum midsection area.

Taking into consideration, that the variation of material's strength properties on the shock adiabatic curve depends also on the impact velocity, the final results of evaluating the puncturing action should be correlated with the experimental data.

Calculation dependences, obtained on the basis of using the experimental data, can be found in various ways. The most acceptable here is such a approach, where the relationships between basic parameters describing the process under consideration are established by analytical dependences derived from the general equations of mechanics, dynamics, physics and other sciences, and the correlation between calculated and experimental data is used only for updating the quantities whose numerical value can not be found accurately enough. It is such

an approach, which will be used hereafter in this work.

So, the solution of a problem of static loading of a plate, rigidly pinched over the perimeter, provides the dependence, which allows to establish the relation between velocity: v_1 of impact of a compact body, having mass m_d , and the barrier of thickness h , at which the stresses arise in a barrier, which do not exceed the elastic limit of barrier material. This dependence is written in the general form as follows:

$$v_s = a(h/m_s^{1/3})b \quad (3.4)$$

If the body has a shape of sphere with radius r_s , then, obviously, dependence (3.4) is convenient to be written as

$$v_s = a' (h/r_s)b' \quad (3.5)$$

In these expressions the coefficients a , $a' b$ and b' were updated from the experiments. For example, for a barrier made of construction duralumin and a steel ball $a' = 110$ m/s and $b' = 0.707$.

A similar approach can be used for estimating the puncturing action of compact bodies over thin barriers.

As noted before, the result of striker interaction with a metal barrier and a barrier made of composite are different outwardly. However, from the viewpoint of interaction mechanism accompanied by energy exchange and, hence, with respect to estimating the probability of barrier puncturing by a striker,

these two results are quite similar. For example, the common point of these mechanism is the fact, that the kinetic energy of a striker is consumed for barrier's material destruction in some volume and for accompanying processes (shock waves appearance, striker's and barrier's material heating, etc.). The common point is also the presence of two typical impact stages: the stage of insertion, at which the barrier resistance force grows as the contact area increases up to the striker's maximum midsection area, and the stage of quasistationary striker motion in a barrier, if the striker is strong enough and retains its integrity. When the striker is destroyed on the barrier surface, the mechanism of interaction of barriers and striker's particles will be so complicated, that it hardly be described mathematically.

The difference between two barriers compared consists in the mechanism of barrier's material destruction (deformation). The shearing strains usually prevail in metal barriers, the volume of destroyed barrier being close to the volume of a cork broken away. In composite barriers the volume of destruction will be much greater, and in this case the character of destruction of matrix material (resin, usually) and filler material (a filament or cloth) will be different. The filler material possesses high viscosity as a rule, and, thus, its extension is accompanied by barrier stratification and cracking, which finally leads to increasing of total destruction volume.

In spite of the difference in described mechanisms of barrier material destruction, a single calculation scheme may be

used for establishing dependencies between striker's kinetic energy and material destruction energy. This single scheme is based on general conservation laws of mechanics. This phenomenon is illustrated in a more complete and visual manner by a scheme of interaction of strong striker with a metal barrier, shown in Fig. 3.1.

This model considers the inelastic impact of a compact body, having mass m_s and velocity v_s , with a barrier of thickness h . At first., the body inserts into a barrier, which results in shearing strains and cork formation. The barrier resistance force is caused at this moment by tangential stress τ and equal to its product by the shearing strain surface area at the current moment of time. This area is equal to the product of h by the hole perimeter along the line contact between the body head and the facial surface of a barrier. At time $t = t_1$ the body inserts to a full height of a head part; and the mentioned perimeter and the resistance force, as well as the deformed material volume and a cork mass reach their highest values at this moment. Beginning with this time the "body-cork" system starts moving in the barriers hole. This motion is slowed down by forces of friction of a cork over hole's walls, these forces being caused by tangential stresses τ . At time t_2 the cork completely gets out from the rear side of a barrier. The barrier is considered to be punctured, and the "body-cork" system acquires velocity v_2 , that just has to be determined. Thus, in N.A.Slezkin's model the initial energy of a body consumes to material deformation in a volume equal to the cork volume and to

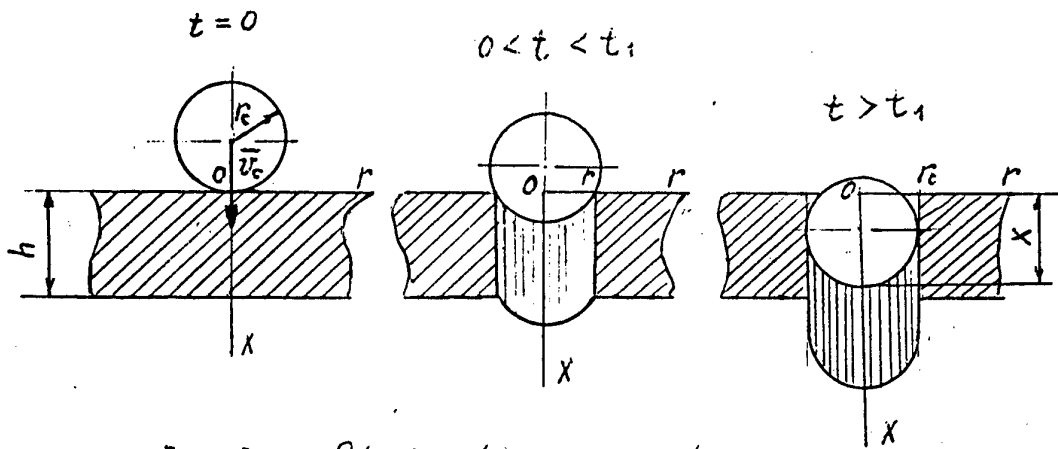

Fig. 3.1. Striker/barrier interaction

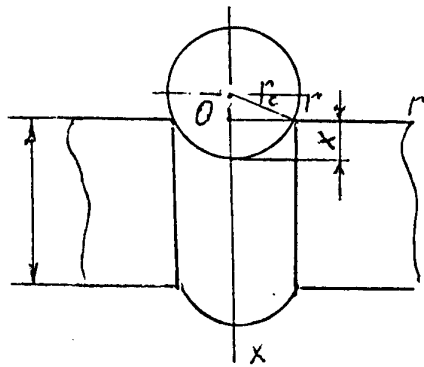

Fig. 3.2

imparting to it velocity v_2 , which is equal to the initial velocity of projectile (body) motion behind a barrier.

To describe the above-mentioned process mathematically we shall assume, that the body has spherical shape with radius r_s and the same mass

$$m_s = (4\pi r_s^3 \rho_s) / 3 \quad (3.5)$$

where ρ_s is the mean density of a body.

At time $0 < t < t_1$ the cork mass m will be determined by the expression

$$m = \pi r^2 h \rho_b \quad (3.6)$$

where ρ_b is barrier's material density;

r is the radius of a line, which determines the contact of a ball with the facial surface of a barrier;
and the barrier resistance force will be

$$F_1 = 2\pi r h \tau \quad (3.7)$$

According to the mechanics theorem of system's momentum variation, one can write:

$$d [(m_s + m)v] = - F_1 dt \quad (3.8)$$

Substituting into this equation the values of m and F_1

determined by expressions (3.6) and (3.7), multiplying both sides of resulting equation by $[(m_c + m)v]$ and noting, that $v dt = dx$, we obtain instead of (3.8)

$$d [(m_s + m)v]^2 = -4\pi h(m_s + m) r dx \quad (3.9)$$

Now we find the relation between x and r quantities. We get from Fig. 3.2

$$x = r_s - (r_s^2 - r^2)^{1/2}, \quad (3.10)$$

which yields:

$$dx = r dr / (r_s^2 - r^2)^{1/2}.$$

Substituting this expression into (3.9) and making integration from the initial values of parameters $r = 0$; $m = 0$; $v = v_c$ up to final ones, corresponding to ball insertion to a half of diameter, where $r = r_c$, $m = m_c$ and $v = v_1$, we obtain after some transformations and introduction of the mass ratio

$$\alpha = m_o / m_s \quad (3.11)$$

the following equation:

$$v_s^2 = (1+\alpha)^2 v_1^2 + \pi\alpha/\rho_b + 3\pi\alpha^2/4\rho_b \quad (3.12)$$

At the second stage of the "body-cork" system motion mass m_o remains constant, and the force of resistance will be

$$F_2 = 2\pi \tau_s (h + r_s - x) \tau .$$

Using the mechanics theorem and performing subsequent transformations in the same manner, we find

$$(1+\alpha)^2 v_1^2 = (1+\alpha^2) v^2 + 2\tau' h\alpha (1+\alpha)/\rho_b r_c .$$

A simultaneous consideration of this expression together with (3.12) allows to eliminate the intermediate parameter v_1 -system's velocity at the end of the first interaction stage - and to obtain the following calculation formula for finding velocity v_2 :

$$\begin{aligned} v_2^2 = v_1^2 / (1+\alpha^2)^2 - \pi\tau\alpha/\rho_b (1+\alpha)^2 - 3\pi\tau\alpha^2/4\rho_b (1+\alpha)^2 - \\ - 2\tau' h\alpha/\rho_b r_s (1+\alpha) \end{aligned} \quad (3.13)$$

In this expression the terms containing τ and τ_1 take into account the body energy losses for overcoming the barrier resistance forces at various sections.

Letting $\tau = \tau' = 0$, we shall have from (3.13) with due account of the designation (3.11):

$$m_s v_s = (m_s + m_0) v_2 ,$$

which corresponds to the theorem of system's momentum conservation at inelastic interaction.

Expression (3.13) for $v_2 = 0$ allows to obtain the formula

for determining the minimum velocity v_{sm} of a body, at which the barrier with thickness h can still be punctured:

$$v_{sm}^2 = \pi\alpha/\rho_b + 3\pi\alpha^2/4\rho_b + 2\tau' h\alpha(1+\alpha)/\rho_b r_c \quad (3.14)$$

In accordance with designations (3.11), (3.5) and (3.6) we find for $r = r_s$:

$$\alpha = 3\rho_b h/4\rho_s r_s .$$

Taking this expression into account, one can write instead of (3.14):

$$v_{sm}^2 = a(h/r_s) + b(h/r_s)^2 + c(h/r_s)^3 \quad (3.15)$$

The expressions for a , b and c coefficients can easily be found by reducing similar terms at corresponding powers of argument h/r_s . One should emphasize, that all these coefficients can be determined quite approximately, because each of them includes parameters τ or τ^1 as factors, whose values depend on the impacting body velocity and on the other parameters and, hence, they can not be known correctly. Taking this fact into account, expression (3.15) is worth to be used directly for approximation the sought dependence

$$v_{sm} = f(h/r_s),$$

by finding the values of a, b and c coefficients from the experimental data directly.

Similar dependences can also be obtained for the body of other, more arbitrary shape by choosing a more general quantity

$$h/m_s^{1/3}$$

as an argument. In this case the general expression will be similar to formula (3.15):

$$v_{sm}^2 = a_1(h/m_s^{1/3}) + b_1(h/m_s^{1/3})^2 + c_1(h/m_s^{1/3})^3 \quad (3.16)$$

The analysis indicates, that when coefficients a, b, c or a_1, b_1, c_1 are determined successfully enough, formulae (3.15) and (3.16) allow to obtain a rather accurate dependence $v_{sm} = f(h/m_s^{1/3})$ in a rather wide range of argument $h/m_s^{1/3}$ variation, which is of great importance for the problem of space objects impact under consideration.

An approximate form of dependence (3.16) is shown in Fig. 3.3 for two materials, which differ in specific strength value τ/ρ_b .

By comparing expressions (3.13) and (3.14) one easily obtains the following formula for calculating the initial velocity of impacting body and a cork behind a barrier:

$$v_2 = (v_s^2 - v_{sm}^2)^{1/2} / (1 + \alpha) \quad (3.17)$$

In case of necessity the dependence (3.17) can also be correlated with the experimental data and presented in the form of

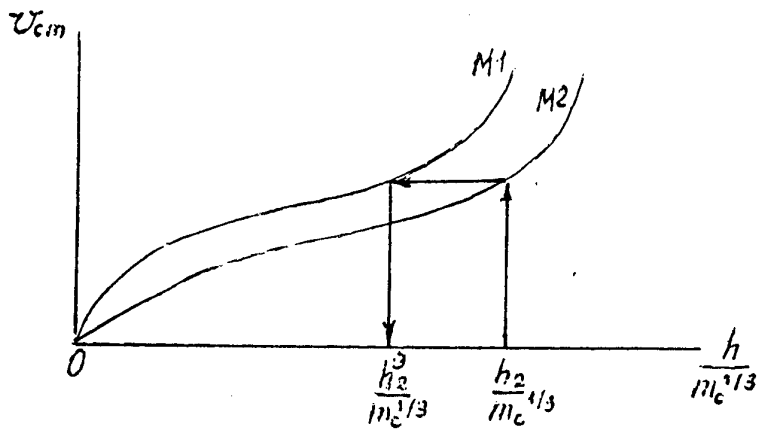

Fig. 3.3

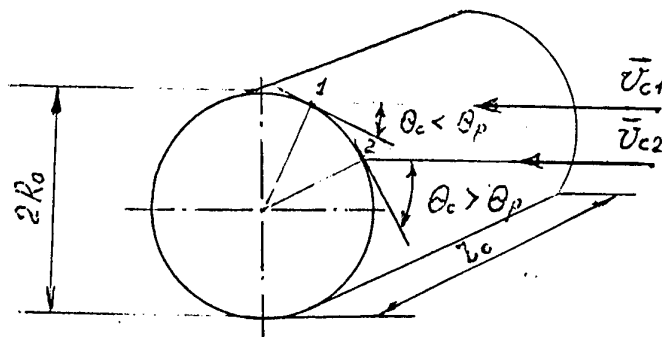

Fig. 3.4

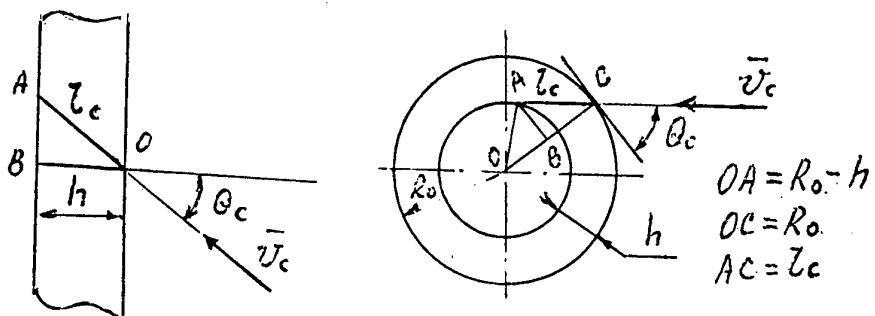

Fig. 3.5

$$v_2 = K(v_s^2 - v_{sm}^2)^{1/2},$$

where K is a correlating factor, which, by the way, should be less than unity in accordance with (3.17);

v_s is an actual impact velocity;

v_{sm} is an extreme velocity of barrier puncturing, determined by expressions of type (3.15) or (3.16).

If in the considered scheme of striker interaction with a thin barrier the tangential stresses τ and τ_1 and shearing strains are replaced by equivalent stresses τ_e and τ'_e , arising at composites destruction, and the cork mass m_c is replaced by some equivalent mass m_{oe} of destroyed material, then the above dependences (3.15), (3.16) and (3.17) will be exactly the same to an accuracy of constant factors. Thus, these formulae may be recommended for approximating the experimental data on finding such a velocity v_{sm} , at which a striker of mass m_s punctures a screen of thickness h made of any material including composition one. However, for non-metal materials one must consider, in addition, the question of establishing the relation between the striker mass m_s and its characteristic size r_s and the mass m_{oe} of material broken away from a barrier, as well as the volumes W_{od} of destroyed material (cracked or stratified, etc.). If the shape of a hole in a punctured barrier is supposed to be ellipse with semi-axes J_x and J_y , which are proportional to r_s ($J_x = K_1 r_s$; $J_y = K_2 r_s$, where K_1, K_2 are proportionality factors), then the following formula may be

proposed for determining m_{oe} :

$$m_{oe} = K_b m_s (\rho_b/\rho_s)(h/r_s), \quad (3.18)$$

where K_b is the factor found from the experiment;

ρ_s, ρ_b are densities of striker and barrier materials.

One should emphasize, that in accordance with (3.18) the mass of broken-away material is inversely proportional, other things being equal, to the striker material density ρ_s .

To find the volume of stratified or cracked materials from (3.18), one easily obtains the formula

$$W_1 = K_1 W_s (h/r_s),$$

where K_1 is concordance factor;

W_1 is the striker volume.

One should remember, that concordance factors K_b and K_1 will depend on the striker velocity v_s . Therefore, in analyzing this issue one should find the values of these factors, which correspond, first of all, to the extreme velocity of barrier puncturing v_{sm} , and then one should study the character of their variation at velocities $v_s > v_{sm}$.

3.2. The evaluation of bodies' puncturing action at impact with multi-layer barriers

The space objects structure has, as a rule multi-layer

shells consisting of several layers of homogeneous materials. In some cases, the barriers may be separated in space. However, in the majority of cases they represent a monolithic, multi-layer barrier.

When the barrier are spaced at distances, the stated problem is solved rather easily. It is solved successively - "from layer to layer". In this case, naturally, the calculation dependences for determining velocities v_{sm} and v_2 must be obtained for various materials of barrier.

The solution of the problem for monolithic barriers is more complicate. Since the ratio of thicknesses of each of barrier layers may be quite different, this problem can not be solved by considering the barrier destruction mechanism according to a single scheme. More logical is consider the version of re-calculating a multi-layer barrier to single-layer one of equivalent thickness. Remind that in such cases for metal barriers one finds some equivalent thickness h_e of a barrier made of one material with respect to thickness h of a barrier made of the other material. In the engineering calculation practice one uses most frequently the steel or duralumin barriers as an equivalent. The formula for finding the equivalent thickness is as follows:

$$h^e = h K_d^2 \tau^e / K_d \tau , \quad (3.19)$$

where h , h^e is the barrier thickness and its equivalent thicness;

$\tau \leq \tau^e$ is the destroying tangential stress of barrier's and its equivalent's material;

K_d, K_d^e are dynamical strengthening coefficients for the same materials.

Formula (3.19) for finding the equivalent thickness of a multi-layer non-metal barrier can not be applied now, in fact, because of the absence of the values of quantifies, which are mentioned here. But the actual problem consists in a more essential thing. The point is, that not for all materials the destruction in a cork volume occurs in the form of shearing strains. Therefore, it may occur, that the destroying tangential stresses do not characterize strength properties of various materials.

Taking this fact into account, one may propose the other approach to the determination of an equivalent thickness of a single-layer barrier possessing the same resistance to impact action of bodies, as a multi-layer barrier under consideration. The equivalent thickness is proposed to be determined from the final result - velocity v_{sm} , rather than from the values of intermediate parameters (for example, τ, K_d). This problem can be solved in the following way.

Suppose, that one should determine the equivalent thickness h_1^e of a barrier for the shell consisting of two layers with thickness h_1 and h_2 . The equivalent should be determined with respect to strength properties of the first barrier's material.

To solve this problem, one must know the dependences of (3.16) type obtained for each of two materials. If the mass m_s

of impacting body is known in this case, then one must calculate parameter $h_2/m_c^{1/3}$, find velocity v_{sm}^e from the M2 curve (Fig. 3.3) and determine from this velocity parameter $h_1^e/m_s^{1/3}$, using curve M1. In this case the "equivalency" of arguments $h_2/m_s^{1/3}$ will be determined by the fact, that for puncturing the barriers of thickness h_2 and h_1^e , made of different materials, the same velocity v_{sm} will be required. Then the total equivalent barrier thickness h_1^e will be equal to the sum of two thicknesses, namely,

$$h_1^e = h_1 + h_2^e$$

As h_1^e is known, one may determine by formula (3.16) the velocity required for puncturing as barrier of equivalent thickness by letting $h = h_1^e$.

If the body mass m_s is unknown, however, then the equivalent thickness h_2^e must be determined for several values of masses m_{s_i} , specified in some particular range, find corresponding values $h_{2_i}^e$ and then average these values. It is not excluded, that such an approach to equivalent thickness determination may cause new updating of calculation formulae. For example, it may occur, that the values of a_1, b_1, c_1 coefficients in expression (3.16) must be changed, or quantity h_e must be substituted by $h_e^* = K h_e$ (where K is some concurring factor), etc.

3.3. Evaluation of puncturing action of strikers approaching a barrier at some angle

In deriving analytic dependences above it was supposed,

that the body encounters an object at the normal (perpendicular) to an outer surface of the latter. But in practice, however, the body approaches a barrier at some angle, as a rule. This, results, first, in the necessity of taking into account a path passed by a penetrating body in a shell before the moment of the complete puncturing, and, second, in the necessity of taking into account a ricochet, that takes place when the encounter angle θ_s reaches some extreme values θ_r . By the encounter angle θ_s here is meant the angle between the body velocity vector v_s and its projection on the plane tangential to the barrier surface at an impact point (Fig. 3.4) (see page 35^a).

The experiments have shown, that the extreme values of ricochet angles θ_r , other things being equal, increase as the barrier strength grows and, besides, they essentially depend on the shape of barrier's and striker's surfaces at their impact point.

The increase of path, passed by a striker in a barrier before its puncturing, up to $l_s > h$ can be determined, if the object surface is known. If the object has a form of cylinder with plane bottoms, then the dependence $l_s = l_s(\theta_s)$ may be presented as follows (Fig. 3.5) (see page 35^a):

$$J_s = hj/\sin \theta_s - \text{for a plane barrier;}$$

$$[(R_o - h)^2 - J_1^2 \cos^2 \theta_1]^{1/2} + J_s \sin \theta_s = R_o - \text{for a cylindrical barrier.}$$

It's clear, that to determine l_s in the second case the above equation should be solved numerically.

An account of ricochet leads also to considerable decrease of an area of projection of a target S_t , punctured by a striker, on a pictorial plane. It is seen from Fig. 3.4, that the area of body's cylindric part projection on a pictorial plane decreases from $2R_0 l_0$ down to $2R_0 l_0 \cos \theta_r$ and equals as low as 70 % of the total area for the ricochet angle $\theta_r = 45^\circ$. In conclusion we note, that the ricochet phenomenon, arising at an impact of two convex bodies, is virtually not studied so far and requires additional investigations.

4. APPROACHES TO ESTIMATING POST-BARRIER EFFECT OF A STRIKER

4.1 General provisions

When the striker punctures space object's skin, the secondary field of splinters is formed behind the skin at some certain conditions. This field, in which striker's components continue moving, is characterized by fly-away angle θ , mean splinters masses m and velocity of their motion q , as well as by a medium value of coefficient K_{sh} of splinters shape.

Depending on skin material and impact conditions, the value of fly-away angle of secondary splinters may vary within a wide range - from 20 to 60 deg. In this case the linear size of secondary splinters lies in the range of 0.02 to 20 mm, that corresponds to masses of 0.5 to 30g, their mean velocity being 20 to 150% of the striker/skin collision velocity. Secondary

splinters, knocked out from a skin material, and striker components are heated up, due to impact loading of skin material by a striker penetrating into it and by aerodynamic drag of space behind the skin in a gaseous medium, up to very high temperatures reaching 2500 °.

In the case, when the vital aggregates (VA) of the object are injured by secondary splinters, two versions of splinters effect on VA should be distinguished:

- * impact action;
- * action of hot splinters fallen on combustibles.

The impact action of secondary splinters reveals in the following injuring factors:

- * mechanical action caused mainly by failure of object's force components and VAs due to fracturing effect;
- * inflaming action resulting in a fire that arises, when splinters fall into fuel-containing modules of SO;
- * initiating action resulting in explosion of the equipment of dangerously explosive modules;
- * breakup of closed modules due to aero- and hydroshock.

Let us consider the approaches to estimation of these types of actions.

4.2. The probability of aggregate injuring by a single moving splinter

Obviously, the character of above-mentioned actions essentially depends on the average number of splinters N fallen

into VA. The computation method of determining N is usually based on the principle of areas, i.e. the value N is found by formula

$$N = S D \quad (4.1)$$

where S is the area of VA projection on the direction perpendicular to secondary splinters' flux;

D is the splinters flux density.

Density D is calculated from splinters' fly-away law, which is usually determined from the experiment for each SC skin type.

In determining value N one usually applies the assumption, that inside the field of secondary splinters their falling into VA is distributed independently of each other. Then the number of splinters falling into VA may be supposed to be a random value subjected to the Poisson law with mathematic expectation (variance) N. If every splinter injures an aggregate with probability P, then the mean number of injuring splinters will be NP. The number of injuring splinters falling into an aggregate will also obey the Poisson law, but with the variance NP. If splinters are injuring an aggregate independently of each other (without damage accumulation), then the aggregate injuring probability is the probability of its hitting by a single injuring splinter at least. According to the Poisson law, this probability equals

$$P = 1 - \exp (- NP) \quad (4.2)$$

Note that the same result is obtained, if P is multiplied by the aggregate area S, rather than by a mean number N of

splinters falling into an aggregate, i.e. if area S is substituted by a normalized vulnerable area

$$S_v = D S, \quad (4.3)$$

Multiplying S_v by the splinters' flux density D , one obtains the mean number of splinters falling into the given vulnerable aggregate area:

$$N_v = S_v D = NP.$$

Then formula (4.2) assumes the form

$$P = 1 - \exp(-D S_v) \quad (4.4)$$

In order to determine the vulnerable VA area, the latter one is very often convenient to be represented in the form of parallelepiped. In this case not more than three VA faces may be injured in the aggregate, i.e. formula (4.4) will be written as

$$P = 1 - \exp\left(-D \sum_{i=1}^3 S_{vi}\right) \quad (4.5)$$

where i is the conventional number of an aggregate face.

Obviously, S_v in formula (4.5) depends on the mass and shape of injuring splinters, as well as on the impact velocity. Let us consider the dependence for determining S_v as applied to each type of actions.

4.2.1. Mechanical (puncturing) action

The mechanical (puncturing) action of secondary splinters is, perhaps, the most typical and varied type of their interaction with VA. This variety is related to the physical

phenomena, which arise when splinters puncture the aggregate body. Since the velocities of secondary splinters do not exceed 2500 m/s (even if the impact velocity of a striker, that forms these splinters, is an order of magnitude higher, than this value), the calculation formulae for estimating the puncturing action of secondary splinters may differ from similar formulae obtained for a striker.

To calculate the VA vulnerable area with respect to splinters' mechanical action, one can use the relation

$$S_v = \begin{cases} 0 & \text{for } h_e > h_{\text{extr}} \\ S_f \sin \alpha & \text{for } h_e < h_{\text{extr}} \end{cases} \quad (4.6)$$

where h_e is the equivalent VA body thickness with respect to duralumin;

h_{extr} is the extreme duralumin barrier thickness, punctured by a splinter;

S_f is the initial module's face area;

α is the angle between the splinter impact velocity vector and an aggregate's face under consideration.

Denoting the aggregate body thickness by h , one writes the expression

$$h_e = K_n h,$$

where K_n is the coefficient whose value depends on physico-mechanical properties of the VA body.

The extremely punctured thickness of a duralumin barrier is determined by the expression

$$h_{\text{extr}} = m^{1/3} \rho^{2/3} v_s^2 f_1 (k_1 k_{\text{sh}}) k_2 f_2(\alpha)$$

where ρ is the splinter density;

k_1 is the coefficient that takes into account the change of splinter's shape after puncturing a barrier;

k_2 is the energy coefficient of transition to the duralumin equivalent;

$f_2(\alpha)$ is the function that takes into account the angle of splinter's falling on a barrier.

4.2.2. Inflaming action

The value of the vulnerable area of splinter's face in Eq. (4.5) is determined by formula

$$S_v = \begin{cases} 0 & \text{for } h_e > h_{\text{extr}} \\ S_f \sin \alpha P_{\text{ign}} f_3(P) & \text{for } h_e < h_{\text{extr}} \end{cases} \quad (4.7)$$

where h_e , h_{extr} are determined by dependences given in p. 4.2.1 ;

$f_3(P)$ is the function that takes into account the stoichiometric conditions under which the highly-inflammable materials are inflamed;

P_{ign} is the ignition probability.

The probability of ignition of highly-inflammable materials is determined by formula

$$P_{\text{ign}} = \begin{cases} 0 & \text{for } v_s \sqrt{S_M} \leq \nu_1 \\ (v_s \sqrt{S_M} - \nu_1) / (\nu_2 - \nu_1) & \text{for } \nu_1 < v_s \sqrt{S_M} < \nu_2 \\ 1 & \text{for } v_s \sqrt{S_M} > \nu_2 \end{cases}$$

where S_M is splinter's maximum midsection area;

ν_1, ν_2 are experimentally found coefficients depending on physico-chemical properties of combustibles.

4.2.3. Initiating action

The probability of initiating of dangerously explosive module's equipment is determined by formula (4.5), in which the vulnerable area is

$$S_v = \begin{cases} 0 & \text{for } v_s \leq k_1 v_{0.5} \\ S_f P_n \sin \alpha & \text{for } k_1 v_{0.5} \leq k_2 v_{0.5} \\ S_f \sin \alpha & \text{for } v_s \geq k_2 v_{0.5} \end{cases} \quad (4.8)$$

The quantity $v_{0.5}$ in formula (4.8) denotes the velocity of splinter encounter with the module face, at which the initiating probability is $P_i = 0.5$. The value of this velocity, as well as coefficients k_1 and k_2 , is determined from the experimental data ad under strictly stated conditions.

The initiating probability is

$$P_i = \begin{cases} 0 & \text{for } v_s \leq k_1 v_{0.5} \\ (v_s - k_1 v_{0.5}) / [v_{0.5} (k_2 - k_1)] & \text{for } k_1 v_{0.5} \leq v_s < k_2 v_{0.5} \\ 1 & \text{for } v_s \geq k_2 v_{0.5} \end{cases}$$

4.2.4. Action due to aero- and hydro-shock effects

The destroying action of aero- and hydroshock effects takes place, when the flux of splinters strikes closed VA modules filled with gas or liquid. The dependence for determining the probability of VA injuring due to aero/hydroshock effects differs in its appearance from formula (4.5):

$$P = \begin{cases} 0 & \text{for } E_{sp} < E_{sp}^{cr} \\ 1 & \text{for } E_{sp} > E_{sp}^{cr} \end{cases} \quad (4.9)$$

In relation (4.9) the specific energy of the field of splinters is determined by formula

$$E_{sp} = D m v_s^2 K(\alpha) / 2,$$

where $K(\alpha)$ is empirical factor depending on the approaching angle.

The critical specific energy E_{sp}^{cr} depends on splinters' field parameters, on the angle between the impact velocity vector and the surface of module's face under consideration, as well as on strength properties of a module stricken by

splinters. Then

$$E_{sp}^{CF} = C_0 N m / [K_{sh} K(P, \xi)],$$

where C_0 is the energy coefficient characterizing the strength properties of a module;

m, N are the mass of one of splinters and the number of splinters striking the module under consideration, respectively;

$K(P, \xi)$ is the coefficient depending on pressure and environment state in a closed module affected by a flux of splinters.

4.3. Inflaming action of hot splinters

The action of hot splinters fallen on VA consists in inflaming combustible materials.

If the initial temperature of combustible is denoted by T_0 and the temperature of a hot splinter - by T_m then, if the heat conductivity λ of combustible is known, one may write the expression for heat Q imparted to a combustible:

$$Q = t \lambda S (T_m - T_0) / a \quad (4.10)$$

where a is the depth of a heated - up layer of combustible;
 S is the heated area.

On the other hand, the combustible with the known heat

conductivity C and density ρ absorbs the heat

$$Q = A c \rho a (T_m - T_o) \quad (4.11)$$

where A is the proportionality factor.

Then, equating expressions (4.10) and (4.11) and combining all constants for the given combustible into the coefficient k , we obtain

$$a = k \sqrt{\bar{t}} \quad (4.12)$$

where $k = \sqrt{\lambda S / A c \rho}$.

If the heat conductivity of combustible is high enough, then the material will not inflame, since the heat from burning splinters will be eliminated into the material depth without any temperature growth. Hence, in order that the object be inflamed, the inequality

$$dQ/dr > \lambda S dT/dx \quad (4.13)$$

must be met, where x is the coordinate directed along the heat radiation from a splinter.

One may write in formula (4.13) approximately:

$$dT/dx \approx (T_m - T_o)/a .$$

Then the heating-up depth required for inflammation will be

$$a_{cr} = \lambda S (T_m - T_o) / (dQ/dt) \quad (4.14)$$

Using the above dependencies, we shall write the expression for determining the combustible inflammation probability as

$$P_{inf} = \begin{cases} 0 & \text{for } a < a_{cr} \\ 1 & \text{for } a > a_{cr} \end{cases} \quad (4.15)$$

4.4. Complex accounting of various types of secondary splinters' action

The estimation of the probability of space object failure by several types of secondary splinters action becomes more complicate. In this case the general structure of object injury may include the combination of several VAs having different vulnerability. This circumstance may be taken into account in the most complete manner by using the models based on static tests. Then, denoting the object failure probability as W , one can determine its value by averaging over all implementations, i.e.

$$W = 1/n \sum_{j=1}^n P_j ,$$

where n is the number of implementations.

In such a model the following initial data should be specified:

- * design characteristics of the object and its VAs;
- * striker characteristics;
- * conditions of striker encounter with object's skin;
- * vulnerability characteristics of object's VAs.

The space object surface may be specified by the second-order equation in the object-centered coordinate system, which has a form

$$\begin{aligned} a_{11}x^2 + a_{22}y^2 + a_{33}z^2 + 2a_{12}xy + 2a_{13}xz + 2a_{23}yz + \\ + 2a_{14}x + 2a_{24}y + 2a_{34}z + a_{44} = 0 \end{aligned} \tag{4.17}$$

where $a_{i,j}$, $i = 1...4$; $j = 1...4$ are coefficients describing object's coordinate.

In order to restrict the surfaces of individual space object's structure components, one must use, along with equation (4.17), the planes

$$\begin{array}{ll} x = x_i & x = x_f \\ y = y_i & y = y_f \\ z = z_i & z = z_f \end{array}$$

where x_i , y_i , z_i , x_f , y_f , z_f are the values characterizing initial (with subscript i) and final (with subscript f) dimensions of object's structure components under consideration.

The scattering of striker hitting points over the object structure may be chosen uniform. In this case the hitting point coordinates should be specified by a quasirandom numbers generator in the given model.

To describe the object VA vulnerability in a program, the VAs should be represented in two forms: if VAs are either situated immediately adjacent to object's skin or represent a single whole body with the latter one, then the outer contours of these VAs are specified by equation (4.17). The VA boundaries are restricted in this case by additional planes perpendicular to the axes of a target-centered coordinate system.

If, however, the VA represents an aggregate being outside the outer contours of object's structure, then such VAs are specified as parallelepipeds with sides a_x , a_y , a_z and a

center placed at a point with coordinates x_a , y_a , z_a with respect to the origin of an object-centered coordinate system.

As the point of striker hitting an object skin is determined, one calculates the parameters of a secondary field of splinters: the fly-away angle and density of splinters, the mean values of mass, velocity and shape factor of splinters.

Further, according to a logic system of space object injury by a striker, the fact of VA injury by any type of splinter's action is successively analyzed.

The technique described above takes into account the features of injuring effect of secondary splinters on object's VA and allows to determine the probability of space object failure by a single or several strikers.