

313181

JPRS-UMM-84-017

25 September 1984

USSR Report

MACHINE TOOLS AND METALWORKING EQUIPMENT

DISTRIBUTION STATEMENT A
Approved for public release
Distribution Unlimited

DTIC QUALITY INSPECTED 3

19980317 185

FBIS FOREIGN BROADCAST INFORMATION SERVICE

REPRODUCED BY
NATIONAL TECHNICAL
INFORMATION SERVICE
U.S. DEPARTMENT OF COMMERCE
SPRINGFIELD, VA. 22161

6
38
A03

NOTE

JPRS publications contain information primarily from foreign newspapers, periodicals and books, but also from news agency transmissions and broadcasts. Materials from foreign-language sources are translated; those from English-language sources are transcribed or reprinted, with the original phrasing and other characteristics retained.

Headlines, editorial reports, and material enclosed in brackets [] are supplied by JPRS. Processing indicators such as [Text] or [Excerpt] in the first line of each item, or following the last line of a brief, indicate how the original information was processed. Where no processing indicator is given, the information was summarized or extracted.

Unfamiliar names rendered phonetically or transliterated are enclosed in parentheses. Words or names preceded by a question mark and enclosed in parentheses were not clear in the original but have been supplied as appropriate in context. Other unattributed parenthetical notes within the body of an item originate with the source. Times within items are as given by source.

The contents of this publication in no way represent the policies, views or attitudes of the U.S. Government.

PROCUREMENT OF PUBLICATIONS

JPRS publications may be ordered from the National Technical Information Service (NTIS), Springfield, Virginia 22161. In ordering, it is recommended that the JPRS number, title, date and author, if applicable, of publication be cited.

Current JPRS publications are announced in Government Reports Announcements issued semimonthly by the NTIS, and are listed in the Monthly Catalog of U.S. Government Publications issued by the Superintendent of Documents, U.S. Government Printing Office, Washington, D.C. 20402.

Correspondence pertaining to matters other than procurement may be addressed to Joint Publications Research Service, 1000 North Glebe Road, Arlington, Virginia 22201.

Soviet books and journal articles displaying a copyright notice are reproduced and sold by NTIS with permission of the copyright agency of the Soviet Union. Permission for further reproduction must be obtained from copyright owner.

JPRS-UMM-84-017

25 September 1984

USSR Report

MACHINE TOOLS AND METALWORKING EQUIPMENT

FBIS

FOREIGN BROADCAST INFORMATION SERVICE

REPRODUCED BY
NATIONAL TECHNICAL
INFORMATION SERVICE
U.S. DEPARTMENT OF COMMERCE
SPRINGFIELD, VA. 22161

NOTE

JPRS publications contain information primarily from foreign newspapers, periodicals and books, but also from news agency transmissions and broadcasts. Materials from foreign-language sources are translated; those from English-language sources are transcribed or reprinted, with the original phrasing and other characteristics retained.

Headlines, editorial reports, and material enclosed in brackets [] are supplied by JPRS. Processing indicators such as [Text] or [Excerpt] in the first line of each item, or following the last line of a brief, indicate how the original information was processed. Where no processing indicator is given, the information was summarized or extracted.

Unfamiliar names rendered phonetically or transliterated are enclosed in parentheses. Words or names preceded by a question mark and enclosed in parentheses were not clear in the original but have been supplied as appropriate in context. Other unattributed parenthetical notes within the body of an item originate with the source. Times within items are as given by source.

The contents of this publication in no way represent the policies, views or attitudes of the U.S. Government.

PROCUREMENT OF PUBLICATIONS

JPRS publications may be ordered from the National Technical Information Service (NTIS), Springfield, Virginia 22161. In ordering, it is recommended that the JPRS number, title, date and author, if applicable, of publication be cited.

Current JPRS publications are announced in Government Reports Announcements issued semimonthly by the NTIS, and are listed in the Monthly Catalog of U.S. Government Publications issued by the Superintendent of Documents, U.S. Government Printing Office, Washington, D.C. 20402.

Correspondence pertaining to matters other than procurement may be addressed to Joint Publications Research Service, 1000 North Glebe Road, Arlington, Virginia 22201.

Soviet books and journal articles displaying a copyright notice are reproduced and sold by NTIS with permission of the copyright agency of the Soviet Union. Permission for further reproduction must be obtained from copyright owner.

25 September 1984

USSR REPORT

MACHINE TOOLS AND METALWORKING EQUIPMENT

CONTENTS

INDUSTRY PLANNING AND ECONOMICS

- Success of Brigade System at Kirov Plant Lauded
(S. Filipenko; PROMYSHLENNOST' BELORUSSII, No 3, Mar 84)... 1
- Mismanagement in Latvian Machine Tool Plants Noted
(SOVETSKAYA LATVIYA, 17 May 84)..... 3

OTHER METALWORKING EQUIPMENT

- Technical Conference on Non-Traditional Machining Reviewed
(V. D. Rivchak; TEKHOLOGIYA I ORGANIZATSIYA PROIZVODSTVA,
No 2, Feb 84)..... 6
- Laser Impulse Drilling Machine Discussed
(L. G. Shafranskiy, et al.; MASHINOSTROITEL', No 5,
May 84)..... 8
- Automated Press-Bending Unit Explained
(V. A. Nedorezov, et al.; AVTOMOBIL'NAYA PROMYSHLENNOST',
No 6, Jun 84)..... 11
- Small Orifice Laser Cutting Machine Viewed
(V. S. Kovalenko, V. P. Dyatel'; MASHINOSTROITEL'
No 4, Apr 84)..... 14
- Technical Specifications of Four-Spindle Drilling Head
(V. N. Rudnitskiy, et al.; MASHINOSTROITEL', No 4, Apr 84). 16
- Operation of Press-Forming Machine Explained
(D. I. Gulyarenko; MASHINOSTROITEL', No 4, Apr 84)..... 17

AUTOMATED LINES AND AGGREGATED MACHINING SYSTEMS

Components, Integration of FMS Viewed
(R. L. Satanovskiy, M. S. Elent; MASHINOSTROITEL' No 4,
Apr 84)..... 19

Layout of Modular, Flexible Assembly Bays Viewed
(V. P. Popov; MASHINOSTROITEL', No 3, Mar 84)..... 23

ROBOTICS

Technical Features of Robotized Machining System Viewed
(V. I. Kokin, et al.; MASHINOSTROITEL', No 4, Apr 84)..... 26

TECHNOLOGY PLANNING AND MANAGEMENT AUTOMATION

Decision-Making Process in Management Automation
(Ye. I. Vorob'yev; MASHINOSTROITEL', No 3, Mar 84)..... 29

INDUSTRY PLANNING AND ECONOMICS

SUCCESS OF BRIGADE SYSTEM AT KIROV PLANT LAUDED

Minsk PROMYSHLENNOST' BELORUSSII in Russian No 3, Mar 84 pp 16-17

[Article by S. Filipenko, head of the Laboratory NOT (for the scientific organization of labor), Gomel' Machine Tool Plant imeni S.M. Kirov: "Under a Single Order"]

[Text] Next year the Gomel' Machine Tool Plant imeni S.M. Kirov marks its 100th anniversary. From mortar mixers, friction hoists, pumps and scalding units to shaping machines, slotting machines, cutting-off lathes and special and multi-position machine tools with programmed operation of the "processing center" type- such is the plant's path over the years of Soviet rule. Two-thirds of the products produced are marked with the quality seal of the state.

In the collective's success a large share belongs to the brigade form of labor organizations.

At the Gomel' Machine Tool Plant imeni S.M. Kirov there are 85 brigades that unite more 1,320 workers. All of them work according to a single order. Among the basic planned indices are the volume of production in standard hours, nomenclature, quantity, production per worker, wages fund and the average wages per worker. The brigade unit (listing of parts and operations assigned to the collective) is the plan-accounting unit. The brigade unit is part of the plan-accounting unit of the shop, that is to say of the machine unit.

Before the first of each month a monthly assignment calculated in standard hours and with a number of workers accounted for is issued to the brigades. Time deadlines and estimates for each part (operation) are also included in the assignment. The sum of the latter, according to the planned parts indicated in the monthly assignment, are the basic earnings.

Having received the assignment for the month the brigade chief undertakes to verify that he will be provided with necessary technical documentation, tools, equipment, materials in the mechanical shops and parts and unitized parts in the assembly shops.

On the basis of the monthly assignment the brigade collective is issued a shift assignment. The brigade chief must keep close track that only those operations

for which there are materials, tools, technical documentation and equipment are included in it. The dispatcher control department produces the shift assignment.

In addition, the brigade chief is obligated:

in necessary cases in agreement with the shift foreman to produce a more effective redistribution of operations among brigade members (with due regard to their qualifications and practical skills);

to control conditions during the course of the shift for the carrying out of the brigade assignment;

to conduct an accounting of the implementation of shift assignments by each brigade member and with the brigade member's participation to analyze the implementation of these assignments at the end of the shift;

to conclude agreements with brigades that are cooperating in the technological chain.

Public minded safeguarding of obligations and personal plans has become a tradition in all brigade collectives. This has created the possibility of bringing forth additional reserves to raise the effectiveness of production. Special attention also has been given to the development of multi-machine capability. Thus, members of A. Selikh's integrated brigade (24 machine tool operators, 4 trouble shooters and 2 crane operators) operate 2-3 machine tools with programmed operation.

The joining of workers into brigades has permitted the raising of labor productivity and the improving of product quality. We will say that the product yield, counting from the beginning of the process, has reached 87 percent. For example, in the integrated brigades of Shop no 5 labor productivity has grown by 15.8 percent, the average wages- by 11.9 percent, and worker turnover has been reduced substantially.

COPYRIGHT: "Promyshlennost' Belorussii", No 3, 1984.

8750

CSO: 1823/244

INDUSTRY PLANNING AND ECONOMICS

MISMANAGEMENT IN LATVIAN MACHINE TOOL PLANTS NOTED

Riga SOVETSKAYA LATVIYA in Russian 17 May 84 p 1

[Article: "Full Utilization for Every Machine Tool"]

[Text] Who among plant managers and even line workers isn't gladdened by the arrival of new equipment! It promises, as a rule, an increase in labor productivity, an improvement in work conditions and more successful fulfillment of plans and socialist obligations.

Quite a bit of modern and high productivity technology arrives in the shops of republic plants and factories. Last year alone more than 1,800 units of new equipment were installed at machine building and metal working enterprises. However, the acquisition and installation of new machine tools is only half the job. It is necessary that not one of them uselessly stands idle and that each one of them operates at capacity. As was stressed at the December 1983 Plenum of the CPSU Central Committee, it is necessary everywhere to promote more broadly the movement to improve the shift system of equipment operations which will activate huge potentials for growth of production efficiency and labor productivity. In addition, the decisions of the February and April 1984 plenums of the CPSU Central Committee demand this approach to the matter.

In the majority of the republic's work collectives the solution of the problems posed by the party was approached in an interested and businesslike manner; care about the utilization of equipment was increased. For example, the workers of the Riga Kompressor plant deserve words of praise. Questions about raising equipment operations efficiency are being decided here in systematic manner: antiquated machine tools are being replaced by new more productive and automated ones, their service areas expanded and second shifts organized for the workers freed as a result of this.

At the Rigakhimmash plant a progressive method for managing the effectiveness of production capacities has been successfully applied based on the experience of the machine builders of the city Sumy. As a result, the plant freed a whole series of machine tools which were transferred to branch plants for the output of additional production.

The certification of worker positions in accordance with the requirements of the scientific organization of labor has greatly helped the workers of the VEF Production Association imeni V.I. Lenin to improve the utilization of

equipment. In conjunction with the reconstruction of plant sections and the creation of new ones, the presence of excess equipment has come to light, the number of worker positions has been reduced as a result of the introduction of new equipment and work has been organized more efficiently.

The collectives of the Daugavpils Transmission Plant, the Avtoelectropribor Plant, the Liyepaysel'mash Plant, the Ventspils Ventilator Plant and a number of other enterprises were able to achieve a high coefficient of shift utilization of equipment. This indicates that in the republic there are many examples of outstanding, first rate experience, and of an economical and public minded approach to the utilization of the machine tool inventory.

At the same time, if one passes through the shops of other enterprises, one can see the other side of the picture. Expensive, unique equipment stands idle at times for whole days or is utilized very few minutes during the course of a shift. Several managers cannot get out of the habit of acquiring as many machine tools and machinery as possible--the saying goes that what one has in reserve is not a drain on the pocketbook. Of course, it's easier to put on line another one or two pieces of new equipment than to figure out how to raise the output of what one already has.

Isn't it true that operations at the Daugavpils Autorepair Plant, RAF, the Spetsstal'konstruktsy Plant, the Talsi metal products plant, and several other enterprises are conducted according to this principle? Last year at these plants the responsible officials did not forget to augment their equipment inventory, but they did lose sight of the need of raising its coefficient of shift utilization. In fact at these enterprises this coefficient is lower than the average for the republic.

Such mismanagement engenders significant losses and is a serious obstacle in the intensification of production. It is very important for our economy to eliminate as quickly as possible this shortcoming and to ensure maximum utilization for each machine tool. It is especially important to achieve this today when the battle to fulfill obligations concerning an over-plan rise of labor productivity by one percent and a reduction of the cost of production by an additional half percent is going on.

First of all it is necessary everywhere to improve the shift system operations of the equipment. It's not a secret that at many enterprises the second shift is not as busy as the first. Usually, their managers explain the situation as one caused by worker shortage. There is some truth in this. However, often masked by such an argument is the unwillingness to take on additional cares. This is not a public minded approach. The party organizations of the enterprises must intensify the demands on managers to improve the shift system operations of machine tools and machinery and to more actively promote the organization of evening shifts in plant shops and sections.

It is necessary in any way possible to support the multi-machine worker movement. The broader it gets, the more possible it is to organize a second shift without increasing the number of workers. It is the duty of Communists to set the tone in socialist competition to augment equipment service areas, and by their

example to attract the interest of their comrades. Enterprise managers are called upon to provide the movement with good engineering support--to more effectively deploy the equipment, to equip it with convenient accessories and devices and to improve the system of moral and material encouragement of the multi-machine worker.

The improvement of the composition of the machine tool inventory requires more attention. Under conditions of large-series production, practice shows that it is more expedient to utilize specialized machine tools than general purpose ones; the specialized equipment is tooled to produce specific parts and to carry out a specific operation. More energetic introduction of machine tools with digital programmed control and unitized machine tools is called for as is the creation of automated equipment sections. The introduction of robotics which will help free many workers and raise the productivity of labor must be approached more boldly.

Enterprise managers and party and trade union committees are urged to strengthen educational work in the collectives and more sternly to demand answers about idle time and equipment breakage as well as for a careless attitude toward equipment. At the same time it is necessary to introduce the work team form of organization and payment for machine tool operators. Work by team or detail will raise the workers sense of responsibility for the effective utilization of equipment. The introduction of a work team requirement of economic self support will promote this further.

It is necessary to introduce more broadly the experience of leading machine tool operators, to react effectively to critical comments of workers who operate equipment and to study attentively all proposals for the improvement of machine tool and machinery operation.

Other ways of raising the effectiveness of equipment operation should be more actively sought and more rapid assimilation of new productive capacity fought for.

8750
CSO: 1823/232

OTHER METALWORKING EQUIPMENT

TECHNICAL CONFERENCE ON NON-TRADITIONAL MACHINING REVIEWED

Kiev TEKHNOLOGIYA I ORGANIZATSIYA PROIZVODSTVA in Russian No 2, Feb 84 p 59

[Article by V.D. Rivchak: "The Wider Implementation of Advanced Structural Material Machining Technology"]

[Text] A republic research applications conference called "State of the Art Manufacturing Processes and Increasing the Effectiveness of the Machining of Hard-to-Machine and Non-Metallic Structural Materials" was held in Dnepropetrovsk. The conference featured more than 180 participants. It was comprised of four sections: techniques and technology for machining high temperature and hard-to-machine materials by cutting tools; the electrophysical machining of materials; mechanization and automatization of factory machining operations; machining of non-metallic materials.

Representatives of the Kiev Institute for Super-Hard Materials of the Ukrainian SSR Academy of Sciences presented some interesting reports of the results obtained in their research at the sessions of the first section. The Institute developed new two-layer cutting inserts with a cubic boron nitride cutting layer, which features a durability that exceeds that of series-produced Hexanite-R inserts by five-tenfold. Studies in increasing the life span of guillotine and disc blades through the use of carbide alloy cutting edges have also been accomplished here, and hobs and gear cutters with carbide cutting elements have been designed and implemented at the factory.

Increasing the life of cutting tools through the application of wearproof coatings, laser beam hardening, and the application of magnetic hardening received considerable attention.

The Dneprodzerzhinsk Industrial Institute imeni M. I. Arsenichev presented reports on the applied problems of turning titanium alloys with diamond cutters, and the effectiveness of utilizing cooling and lubricating fluid in metal machining. Guest from Tashkent shared their experience in the utilization of a preliminary break-in of the cutting tool as a method of increasing its service life.

Conference participants were interested by a report on hard-facing materials as high-speed steel replacements (Kharkov Polytechnic Institute imeni V. I. Lenin). Candidate of technical sciences V. S. Kovalenko of Kiev addressed

the conference with a survey report on the prospective utilization of electrophysical machining methods.

Colleagues of the Dnepropetrovsk Metallurgical Institute imeni L. I. Brezhnev presented the reports "Optimization of the Parameters of Electric Spark Machining Equipment" and "Prospects for the Utilization of Electric Spark Alloying of Machine, Instrument and Tool Parts."

Representatives of the VNIImekhchermet Institute (Dnepropetrovsk) reported on the results of their studies in the electrical resistance machining of hard-to-machine materials. The developments of the Institute have been successfully utilized at a number of enterprises.

Workers at the Dneprovskiy Machine Construction Plant shared their experience in cutting hard-to-machine steels through the heating of the removed layer by an external highly-concentrated heat source.

Representatives of the Sumskiy Manufacturing Association imeni Frunze described the electro-diamond polishing of structural steels and super-fine surface finishing through the application of low-frequency vibration.

An interesting discussion developed at the mechanization and automatization of factory machining operations section of the conference on the utilization of computer-aided design of manufacturing processes. Industrial engineers have achieved significant successes in this area at the Odessa Scientific Production Association, where more than 80 percent of all the manufacturing documentation is produced by computer. Communications regarding the results of the implementation and the prospects of developing computer-aided manufacturing process design systems were given by representatives of the Dnepropetrovsk State University, the "Southern Machine Construction Plant" Production Association imeni L. I. Brezhnev and by speakers from Minsk, Leningrad, Kharkov, Donetsk, Makhachkala, Voroshilovgrad and Kaunas.

The introduction of versatile robot-equipped systems, and the means for increasing the effectiveness of programmable machine tools is also described in several reports and communications.

A new high-productivity technology for cutting polymer materials with a high pressure fluid jet (hydrocutting) was discussed at sessions of the non-metallic material machining section of the conference. Representatives from Kiev and Kherson offered some interesting reports on this process.

The utilization of diamond and boron-impregnated tools for machining cast and ceramic structural polymers also attracted much attention.

The recommendations made at the conference were aimed at the wider enlistment of research developments and state-of-the-art manufacturing technique in the electrophysical and mechanical machining of hard-to-machine materials, and in the automatization of the design of manufacturing processes, elevating the efficiency of machine tools with numerical program control, and in the hydraulic and diamond tool machining of polymers.

COPYRIGHT: UkrNIINTL 1984

12678

CSO: 1823/240

OTHER METALWORKING EQUIPMENT

UDC 621.7.044.2

LASER IMPULSE DRILLING MACHINE DISCUSSED

Moscow MASHINOSTROITEL' in Russian No 5, May 84 pp 26-27

[Article by L. G. Shafranskiy, M. R. Nikolayenko, candidates of technical sciences, A. A. Krivonogov, A. M. Mironov, engineers, "Hole Drilling with Lasers"]

[Text] At the Bryansk Tractor Machinebuilding Plant, the possibility was investigated of drilling holes 0.8 to 1.00mm in diameter and 3mm deep for bearings of magnetic relay armatures by laser impulses with an energy of up to 30 joules.

Existing blind holes in relay base plates were replaced by through holes. This change was made by two reference holes 1 and 2 produced along with other holes when punching the intermediate product of the base plate from sheet metal. The depth of the holes drilled by the lasers was determined by the distance between the reference holes from the front edge of the relay base plate. It was adopted as equal to 3mm.

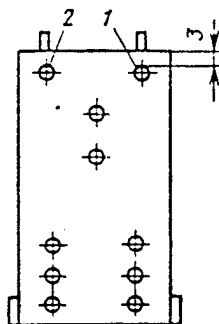

The beam was focused on the front surface of the base plate and, to simplify the experiments, the position of the focus with respect to the part was not changed as the hole channel was being formed; therefore, a large part of the holes was formed by the action of a defocused beam. Consequently, the channel was formed not as a result of metal evaporation, but due to its melting by a concentrated heat source and a spatter of overheated metal in the form of vapors and microscopic sprays. This spatter leads, on one hand, to nonuniform melting of the walls of the hole channel as a result of which its entering part acquires the shape of an irregular circle and, on the other hand, to particles of molten metal being ejected and its vapors destroy the surface layer of the protective glass of the lens.

Gas protection is one of the most efficient possible ways to protect the laser optics. Coaxial blowing of oxygen or air under pressure of not less than 0.4 megaPa at a minimum diameter of the nozzle that provides free access of the beam to the machined surface, guarantees 100 percent protection of the optics. The hole, 3mm deep, is produced by four laser impulses. The shape of the hole channel is more nearly cylindrical and is produced by using air as a protective medium.

Experimental data shows (see Table) that the diameters of the inlets and exits of the holes are larger than the average diameter of the hole channel, independently of laser radiation power. Apparently, this is due, on one hand, to the action of a conical shape of the beam and, on the other hand, to the intensive ejection of a liquid layer of metal from the lower part of the channel when the finishing (fourth) radiation impulse is fed after the through hole was formed.

Table

(1)	Напря- жение на батарее, В	Энергия излуче- ния, Дж	(2) Диаметры отверстий, мм (3)			(6)
			(4)			
			вход- ного	сред- него	выход- ного	
1600	17,4	1,10	0,90	0,96		
1700	21,5	1,32	0,93	1,02		
1800	23,5	1,38	0,98	1,03		

1 -- Battery voltage, volts; 2 -- Radiation energy, joules; 3 -- Hole diameters; mm; 4 -- inlet; 5 -- middle; 6 -- exit.

The armature bearings are inserted in the holes produced by the laser until stopped by the cylindrical surface of the reference holes and press-fitted by prick punching. The strength of fixing the armature bearings in such holes in a basic version was compared by the force required to pull them out of the base plate of the relay. Tests indicated that the armature bearings are pulled

out of experimental and series produced relay plates at forces of 119.5 newtons and 122 newtons respectively, i.e., they are practically the same.

Investigations of channel holes cross sections of the diameter parallel and perpendicular to the vertical plane of the relay base plate, after the armature bearings were torn out, indicated that the plastic deformation of metal due to the press-fit eliminates all deviations in the shape of the channel from the cylindrical.

Lasers can be introduced efficiently for drilling holes in relay base plates only when they are operated in the continuous radiation mode and are equipped with lenses with electromagnetic shutters.

COPYRIGHT: Izdatel'stvo "Mashinostroyeniye", "Mashinostroitel'", 1984

2291

CSO: 1823/310

OTHER METALWORKING EQUIPMENT

UDC 621.961.2.06-52:658.527:629.113.012.853

AUTOMATED PRESS-BENDING UNIT EXPLAINED

Moscow AVTOMOBIL'NAYA PROMYSHLENNOST' in Russian No 6, Jun 84 p 36

[Article by V. A. Nedorezov, L. I. Zhinov, Yu. V. Gerzhidovich, A. F. Bichevoy and V. V. Shcherbina, "Automated Line for Manufacturing Sheet Springs"]

[Text] Pressing operations of cutting, punching, bending, etc. are of great importance in manufacturing springs. One, cutting the initial strip into measured intermediate products, is done on lines consisting of a roller conveyor and a crankshaft press equipped with a cutting die and a movable stop. Then the measured intermediate products are transported to the finishing stamping lines consisting of a heating device and a crankshaft press with a die that has several operating positions. When it is considered that the production program envisions the manufacture of several kinds of springs and that each spring consists of many (up to 15) sheets, it becomes obvious that the traditional technological process has very intense freight flows, requires frequent equipment readjustments and, therefore, large labor expenditures and large service personnel. To avoid this, a new improved technological process for manufacturing sheet springs for the GAZ [Gor'kovsk Automobile Plant] automobile was developed at the Sinel'nikovsk Spring Plant imeni Komintern. It is based on a automated line (see Figure).

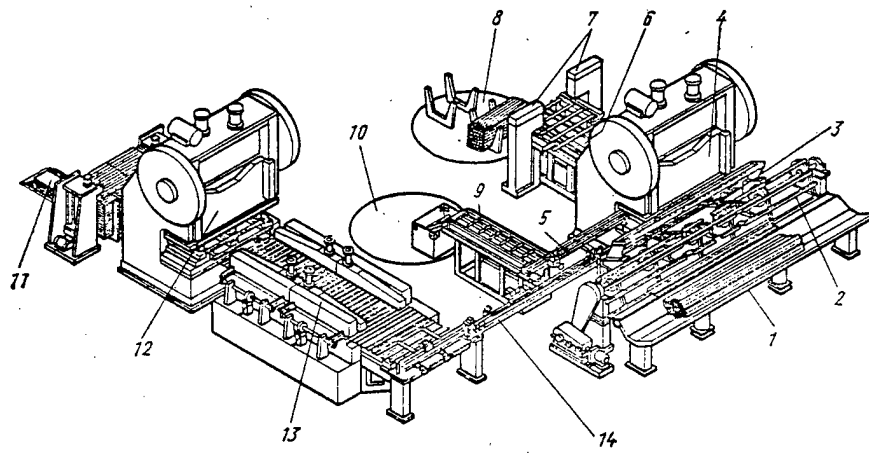

Feeder 1 is shaped like a hinged platform on which a batch of measured intermediate product strips is placed. A pneumatic cylinder rod turns the platform on its bearings and the strip falls into the receiver of device 2 for piece-by-piece feeding. The receiver capacity is up to 20 strips. (All other strips remain on the platform which is loaded by a single-rail overhead crane without the line being stopped).

The device for piece-by-piece feeding of the strips is a scraper-chain conveyor. The height of the scrapers depends upon the thickness of the strips in order to eliminate the possibility of engaging two strips simultaneously. When the conveyor moves, the scrapers grab a strip from the receiver and move it to a slide over which it drops to sloped storage device 3 with devices for leveling and orientation.

The slide is equipped with two rollers: the lower is a driving roller and the upper is a clamping roller. The strip falling on the rollers is moved to the stop. Electrical sensors fix its position on the slide and issue the instruction for beveling or passing to the storage device without beveling. From the storage device, the strip drops onto step-shaped guide-bars that are moved to and fro by a pneumatic drive and feed the strip to the first position of the dies of the model K3133 two-crankshaft press 4 with a nominal force of 2 meganewtons. There are four die positions on the press table on which cutting and punching holes operations are done.

In the first position, the strip is cut into two intermediate products -- left and right. The left part is transported by feed device 14 to heater 13 and then to finishing press 12, while the right part, equal in length to the sum of the lengths of two sheets, passes through the remaining positions of press 4 by a feed device consisting of a grab bar-guides with driven guide blocks. In the last position, the intermediate product is cut into two sheets, the short one of which is sent by device 5 and conveyor 9 to a box on table 10 to be crated, while the other (long one) is sent by device 6 to reaming machine tools 7.

The device for moving the long sheets consists of two rocking levers driven by guide blocks. The levers assume the initial position under the sheet in the down stroke of the slide bar of the press and on the up stroke they turn and drop the sheet onto the sloped slide from where it gets to the chain conveyor and then to the reaming machine tools.

The reaming machine tools are equipped with a beveling device, a device for feeding the sheet to various positions and two reaming heads. The beveling device consists of two disks with radial slots into which the sheet is fed by a conveyor. The disks are rotated around a horizontal axis by a ratchet device driven by a pneumatic cylinder and lay the sheet on the feed device, consisting of stepping grab-bar guides, in the various positions.

After reaming the previously punched holes, the sheet is fed to the sloped slide and over it to packing boxes on rotary table 8.

Heater 13 is a stepping chain conveyor with two rows of radiating units. The intermediate products are transported by the conveyor between the radiating units to the model K3133 finishing press 12 and are heated at given places.

Four die positions are installed on the table of press 12. They execute the operations of bending, cutting the sheet to dimensions and punching holes. The device for moving the sheet to various die positions is made in the form of grab-guides driven by a pneumatic cylinder.

The finished sheet is fed to packing boxes mounted on power-driven cart 11 by the chain conveyor.

Rotary tables and power-driven carts make it possible to change packing boxes without stopping the line.

The operating sequence of all units and devices of the line is determined by control and limit switches.

The introduction of the automated line in production made it possible to increase the productivity of labor 2.9-fold, reduce service personnel from 9 to 4 and increase the metal utilization coefficient from 0.94 to 0.97.

The economic effect of the introduction of the line was 105,000 rubles per year.

COPYRIGHT: Izdatel'stvo "Mashinostroyeniye", "Avtomobil'naya promyshlennost'",
1984

2291

CSO: 1823/322

OTHER METALWORKING EQUIPMENT

UDC 621.9.048.7:621.373.826

SMALL ORIFICE LASER CUTTING MACHINE VIEWED

Moscow MASHINOSTROITEL' in Russian No 4, Apr 84 pp 24-25

[Article by V. S. Kovalenko, doctor of technical sciences, V. P. Dyatel', candidate of technical sciences; "Laser Machining of Holes"]

[Text] In a number of industrial sectors, it is necessary to provide the highly efficient drilling of holes 0.8 to 1.0mm in diameter in pipes with wall thickness within 1.0mm (material of Kh18N10T steel) that have a spatial curvilinear shape. Drilling holes in such pipes is difficult due to the complexity of basing the holes. Difficulties also arise which are related to removing burrs around the holes from the inner surface of the pipe. Moreover, after drilling, it is necessary to ream the upper part of the orifice. Manual labor is used principally in such a technology. Drilling 1.0mm and less in diameter in hard steels is not a simple technological problem because of the frequent breakage of drills (since the pipe must be based manually).

It was proposed to drill such holes by a laser installation designed for this purpose in the Laser Technology Laboratory of the Kiev Polytechnical Institute in order to improve the technological process of making holes in curvilinear pipe parts. The "Kvant-16" series manufactured laser installation was recommended as the basic one to use. To achieve multi-impulse hole-making, the spherical mirrors of the optical resonator of the basic installation were replaced by flat ones and the charge-discharge circuit to feed the incandescent lamp for pumping the active element is changed so that the radiation impulse does not exceed 1 millisecond.

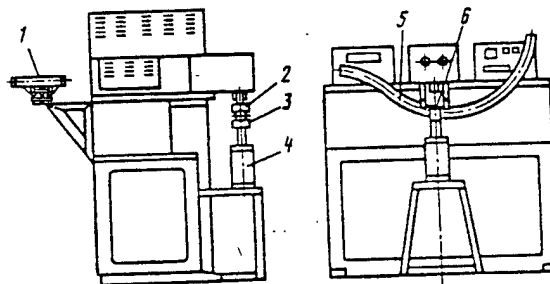

Figure

Type L9-78 laser 1 is installed in the rear part of the laser installation on a special bracket coaxially with the optical axis of the oscillator. This is done so that the focusing zone (the drilling zone) may be observed visually and to reduce the labor-intensiveness of adjusting the optical system of the laser installation. Its radiation is combined with the optical axis of the oscillator and is focused on visible red point 6 which is the focus of the lens. The part to be drilled is based according to two regulated prisms 2. To increase the basing precision 2mm wide prisms are used with a 30mm distance between them. The part is secured by lower prism 3, connected to the plunger of pneumatic cylinder 4 which is actuated by depressing a pedal.

The gas laser begins to operate when the laser installation is connected. The operator supporting the pipe whose surface was previously marked with the locations of the holes, places it between the prisms. When the gas laser is connected, the operator sees a red point on the pipe. The pipe is oriented then so that the marked axis of the hole coincides with the visible red point. After that the operator depresses the pedal that controls the pneumatic cylinder, whose plunger moves out and the lower prism forces the pipe to the upper prism, keeping it in the oriented position. The laser oscillator is connected and the holes are treated with a certain number of impulses. After that, the operator disconnects the oscillator and connects the pneumatic cylinder. The lower prism is lowered, the pipe is freed and the operator orients the pipe again for drilling the next hole.

The holes are drilled in the following modes: radiation energy in an impulse 20 to 25 joules; focal distance of lens 70mm; number of impulses, directed into the treatment zone, 2 to 4; frequency of impulse sequence 0.75 to 1.00 Hz. The diameter of the holes 0.6 to 1.0mm, depth of holes 0.5 to 2.0mm and treatment time is 4 to 8 seconds. The dimensions of the holes are changed by varying the radiation energy, the number of impulses and the location of the treated surface with respect to focus of the lens. Since, in laser processing, the orifices have an inlet cone, reaming is eliminated entirely from the technological process.

The use of laser technology to drill holes in pipe that has a spatial curvilinear shape, makes it possible to eliminate manual drilling of the given holes, as well as to eliminate the necessity of reaming and removing burrs from the inner surface of the pipe. The production cost of one hole is reduced due to saving wages and costs of tools. The effect is obtained by reducing machining time, as well as the auxiliary time since, unlike the machine drilling operation, on the laser equipment, the complicated shape of the intermediate product is oriented and clamped with respect to the tool -- the laser beam with partial automation. Although the proposed version of orienting and securing the pipe appears to be simple, nevertheless it requires a certain amount of manual labor. Therefore, the search continues at present for an optimal version of an automatic process for laser drilling of holes in pipes of complicated spatial shapes.

COPYRIGHT: Izdatel'stvo "Mashinostroyeniye", "Mashinostroitel'", 1984

2291

CSO: 1823/314

TECHNICAL SPECIFICATIONS OF FOUR-SPINDLE DRILLING HEAD

Moscow MASHINOSTROITEL' in Russian No 4, Apr 84 p 47

[Article by V. N. Rudnitskiy, A. Z. Dolgintsev, Yu. P Pankov, candidate of technical sciences, V. M. Mikhaylichenko, engineer: "Four-Spindle Drilling Head"]

[Text] A four-spindle drilling head was developed in the Bryansk Technological Institute for drilling holes in the wheel unit in the ventilating assembly of the TAV-1.5 heat generator.

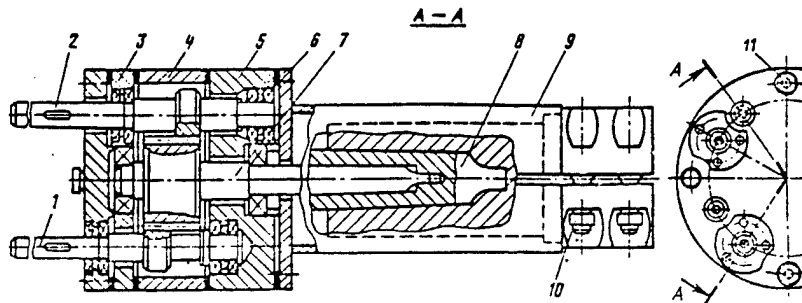

Sections 3, 4 and 5 of the head are connected by four screws 11, two of which pass through bushings designed to center the sections. Coupling 9 is secured on the stationary part of the machine-tool spindle and is clamped by tapered bolts 10. Pinion-shaft 7 enters the hole of coupling 8 installed on the machine tool spindle. Thrust bearings 6 are installed in section 5 to receive the axial loads originating in spindles 1 and 2 when drilling holes. Each spindle has the shape of a stepped shaft with a pinion cut in the middle section ($m = 1.5\text{mm}$).

The machine tool spindle rotation is transmitted to the pinion-shaft which is engaged with the spindle pinions, displaced in height from each other.

The introduction of the drilling head will triple the productivity of labor.

COPYRIGHT: Izdatel'stvo "Mashinostroyeniye", "Mashinostroitel'", 1984

OTHER METALWORKING EQUIPMENT

UDC 621.981.12.073

OPERATION OF PRESS-FORMING MACHINE EXPLAINED

Moscow MASHINOSTROITEL' in Russian No 4, Apr 84 p 14

[Article by D. I. Gulyarenko, engineer; "Press-Forming Machine"]

[Text] The Donetsk Planning Design and Technological Institute designed and introduced at the Sverdlovsk Ore Repair Plant a press-forming machine for making chutes for mounting on the SP202V, scraper conveyors.

The machine operates on the principle of edge-bending presses, i.e., the part is made by the free-bending principle. The spring-loading angle is regulated by interchangeable spacers located on stops, which makes it possible to bend parts of various thicknesses and at various angles. The angle of punch die 2 is 81° . The die is mounted on a hydraulic press.

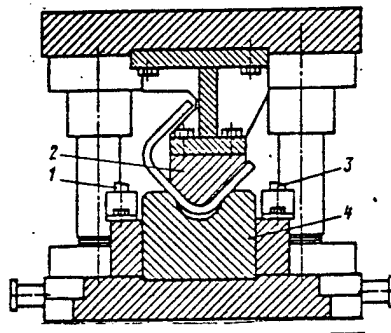

A flat intermediate product is laid on sectional die 4 and moved to rear stops 1. The spring-loaded beveled front supports 3 are pushed down by its weight. On the down stroke of the press slide block, the rear ledge of the part is bent by sectional die 2, after which the part is fixed according to front stops 3 and the front ledge of the part is bent. Since the distance from the axis of the die to the front and rear stops is the same, the height of the chute ledges is also equal within given tolerances.

The die design is considerably simpler for Π - type bending and is universal. Its use makes it possible to reduce the number of stamping equipment and raise the quality of the stamped parts due to the ability to regulate the spring-loading angle by interchangeable spacers. The maximum lengths of the bend is 1.5 meters.

COPYRIGHT: Izdatel'stvo "Mashinostroyeniye", "Mashinostroitel'", 1984

2291

CSO: 1823/311

AUTOMATED LINES AND AGGREGATED MACHINING SYSTEMS

UDC 658.512.2:658.5

COMPONENTS, INTEGRATION OF FMS VIEWED

Moscow MASHINOSTROITEL' in Russian No 4, Apr 84 pp 15-16

[Article by R. L. Satanovskiy, doctor of economic sciences, professor;
M. S. Elent, engineer; "Design and Organization of GAP and GPS"]

[Text] One of the most complicated concepts in the total conception of designing and organizing automated flexible productions (GAP) is related at present to the flexibility of production. This conception, in its totality, takes into account the technical, technological and organizational aspects of modern production. Only by considering them together is it possible to evaluate flexibility from the position of achieving its most efficient magnitude. The technical and technological possibilities of flexible production are manifested in the process of the joint work of all production subdivisions (section, complex and line), i.e., they are realized through the organization of production.

Among the most important definitions of the flexibility concept is adaptivity, i.e., the variety of conditions to which the system can adapt. It is characterized by the number of various products that can be manufactured and by the degree of the design-technological similarity of the manufactured products (type-sizes, types, kinds and classes). The determination of the efficiency of flexible production systems (GPS) consists of finding parameters of an optimal product list and the degree of product similarity that would provide manufactured products at minimum cost.

Thus, for example, designing sections with universal equipment is based on the optimality of the production structure. In this case, a version of the distribution of the products list and the level of their similarity would provide for the manufacturing of the product with minimum expenditures of live and reified labor. Such an approach was approved by the methodological instructions of the USSR Gosstandart and is used in machinebuilding and instrument making enterprises.

In equipping subdivisions with NC machine tools and industrial robots, the evaluation of flexibility is preserved through adaptivity indicators taking into account the specifics of a given production facility. As an example, we will consider a robotized complex for compression molding of plastics, established and functioning at the Leningrad "Elektrosila" Electrical Machinebuilding PO [Production Association] imeni S. M. Kirov. The complex includes

the following: a semiautomatic hydraulic press, an industrial robot, a dispenser device and a control system. The robot is equipped with an interchangeable grip in which the number of loading cavities is in strict relationship with the number of parts being extrusion molded in the press. Loading cavities, heating the molding compound and moving the grip in the plane of the press for the next loading of the molding compound into the compression mold are implemented according to a given program. After the extrusion cycle is completed, a second arm of the robot removes the finished products for their following monitoring.

The design-technological classification of 30 kinds of plastic parts, handled in the robotized complex, established that they belong to three types, two kinds and one classification. The sizes and weights of the parts within each type make it possible to use an interchangeable grip of one kind with a uniform arrangement of cavities along a coordinate grid. Changing over from one type (kind) of parts to another requires additional expenditures for the installation of interchangeable grips and a number of technical devices to insure the given dynamic and accuracy characteristics.

Changing over from an individual grip designed for one type-size to a grip designed for several type-sizes is a considerable reserve for raising the productivity of labor. Taking into account the fact that under conditions of small series production, basic time losses in the operation of the complex are related to the change in the compression molds, they can be reduced by changing over to group compression molds. This is solved by providing software for the robotized complex. Thus, flexibility is increased, current costs for manufacturing compression molds, on the one hand, while on the other hand, one-time (capital) costs of expensive group compression molds and multicavity interchangeable grips increase. To evaluate flexibility, the following formula is used to determine the reduced annual costs:

$$Z_{np} = C + E_H K_1$$

where C -- production cost (as compared to the expenditure items); E_H -- norm coefficient of economic efficiency; K -- capital investments.

Knowing how C and K change in manufacturing extruded parts of one type and when changing over from one type to another, particular values were obtained for Z_{np} and for evaluating the optimal flexibility when the number of positions in the product list increased on the boundary of each type of part. The Figure shows that for the parts of one type, the optimal flexibility of the robotized complex is equal to 5 items, of the second type $(13-10) = 3$ and of the third type $(24-20) = 4$. As a whole, for the 30 positions planned when the complex was built, the curve of reduced annual costs, plotted according to approximated curves C and $E_H K_1$ is represented by the envelope curve Z_{np} , whose minimal value corresponds to the optimal value of product list R equal to 16 positions.

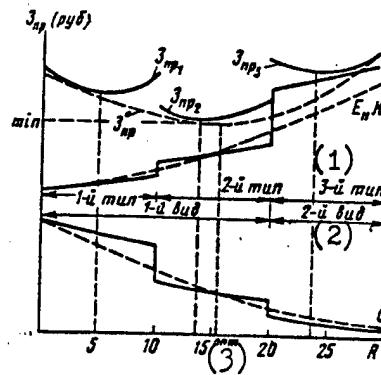

Figure

1 -- 3d type; 2 -- 2nd kind; 3 -- optimal.

Deviation from optimal flexibility O_r^c , that determines the strategy for GAP and GPS development, is evaluated by formula

$$O_r^c = \frac{(R_{\text{fact}} - R_{\text{opt}})}{R_{\text{opt}}} 100.$$

For example, for the given robotized complex, which assimilated only 10 positions of various types in production, the duration from the optimal flexibility is $O_r^c = \frac{10-16}{16} \cdot 100 = 37.5\%$. Thus, reaching optimal R, flexibility is increased by

$$\pi_r^c = \frac{(R_{\text{fact}} - R_{\text{opt}})}{R_{\text{fact}}} 100 = 60\%$$

Such a system of indicators makes it possible to evaluate the flexibility level of GAP and GPS because, at its basis, lies a comparison with an optimal value measured in accordance with $z_{np \text{ min}}^o$.

As shown by the calculation of the flexibility and operation of the robotized complexes built at the "Elektrosila" PO, the initial moment is the substantiation of the possibility of achieving the functional-operational GAP characteristics for manufacturing an entire range of products from a fixed assigned product list. By knowing the dynamics of C and K, it is possible to evaluate the advisability of expanding flexibility further. In this case, it is necessary to differentiate among the strategic, tactical and operational flexibility.

Strategic flexibility, whose sequence of establishing we just considered, is characterized by the degree of similarity of the products and the number of items in the fixed product list for a specific GAP or GPS for a fairly long period of time (a year or more). In series production for which GAP and GPS are primarily created, this product list, during the year, can be manufactured in different amounts and different periods of repetition, which would involve frequency of equipment readjustment. The optimal frequency of such readjustment, evaluated according to GOST 14.004-83 ESTPP [Single System for Technological Preparation for Production] by a so-called coefficient of operations assignment that characterizes the optimal tactical flexibility of production.

The sequence of alternating specific lots during the planned period (month, ten day periods), calculated by taking into account achieving optimal tactical flexibility for the entire assigned product list, may vary. Therefore, the operational flexibility determined for a short period must also be optimal, i.e., oriented to achieving annual production costs calculated for the stages of previously substantiated flexibility.

Thus, the optimization of the flexibility of production systems is a multilevel problem in which the results of solving the upper level (strategy) are the entrance to the second level (tactics) and are directly related to the solutions for the initial dynamic level of GAP and GPS functioning. As confirmed by the experience of industrial enterprises, precisely such a systematic approach makes it possible to solve the complicated problem of finding the optimal flexibility of production systems. Changing over to the evaluation of the flexibility and the magnitude of deviations from the most efficient, i.e., to the characteristic of the flexibility level, is an important direction of the further development of design and organization of GAP in machinebuilding and instrument making.

COPYRIGHT: Izdatel'stvo "Mashinostroyeniye", "Mashinstroitel'", 1984

2291

CSO: 1823/312

AUTOMATED LINES AND AGGREGATED MACHINING SYSTEMS

UDC 658.527.011.56:621.757.06-52

LAYOUT OF MODULAR, FLEXIBLE ASSEMBLY BAYS VIEWED

Moscow MASHINOSTROITEL' in Russian No 3, Mar 84 pp 16-17

[Article by V. P. Popov, engineer: "Flexible Assembly Production Systems"]

[Text] The trend in developing flexible assembly production systems (GSSP) for mass production was caused by an increase in the productivity of labor (up to 50-60 percent as compared to synchronized direct-flow assembly lines) as a result of taking into account more fully their psychophysical factors, more comfortable working conditions for assembly workers, optimal utilization of the brigade form of labor organization, and mechanization facilities and equipment.

For small series production, it is most efficient to reequip assembly production facilities on the basis of the GSSP with their optimal saturation with mechanization facilities, assembly and other equipment (including portable), the creation of comprehensively mechanized work positions, modular assembly, bay sections (with efficient, technological and object specialization) and shops with technological complexes according to the entire "warehouse-assembly-test" cycle.

In recent years, the GPTIikuzmash developed technological projects for assembly shops and sections on the basis of the GSSP. As an example, Fig. 1 shows a section with a production area of 300m² for assembling planetary reducers serviced by 12 workers.

The section consists of two modular assembly bays connected to the shop warehouse with a stacker, -- a modular bay for preparing assembly units, and a modular bay for assembling and testing products. The following is done in the bay to prepare assembly units: gears are assembled with bronze bushings; reducer covers are assembled; gaskets are installed; holes are drilled; detents are installed, etc.

Model P6328 hydraulic press 9 is used with device 10 on an air pillow to feed parts for pressing. Drilling and thread cutting work is done on the vertical-drilling NC machine tool and group equipment (without readjustment for a series of products). Tables 7 and 8 serve as assembling and storing parts and assembly units. Portable pedestals 12 for tools and electromechanical manipulator-16 are used in the section.

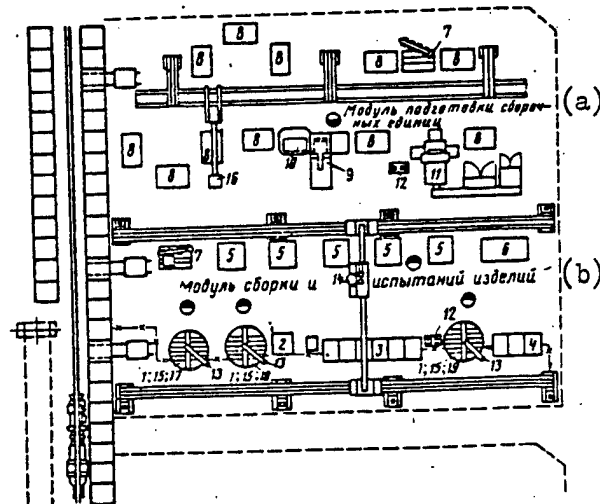

Fig. 1. a -- bay for preparing assembly units; b -- bay for assembling and testing products.

The bay for assembling and testing products is located under overhead crane 14. Here are organized three comprehensively mechanized work positions 13 for assembling and one work position for testing (test stand 5 and oil-filling station 6). Assembling work positions are equipped with two-position rotary assembling tables 1, group tune-up stations 17, 18 and 19 respectively for assembling covers with bearings; assembling camshafts and crankshafts; assembling reducers. While one half (position) of the table is loaded by the automatic crane with crated parts and assembling units, brought from the warehouse on a cart, an assembly worker assembles parts brought in earlier on the second half of the table, using overhead mechanization facilities 15 and manual tools. Thermal-radiation cabinet 2 is located beside the assembly table. Having completed the assembly, the worker turns the table by 180°. The assembled unit is moved under the automatic crane for unloading into storage devices 3 and 4, or to the warehouse, while the freed places are loaded with a new lot of parts and units. The cycle is repeated. The assembly worker is not tied to a rigid assembly rhythm (the manufacturing time for one set is 20 to 30 minutes), since he is doing a technologically completed volume of work. The arrangement of the section is universal for series or small group series assembly.

For smaller series production and single unit production, a shop (bay) was designed for assembling hydraulic turbogenerator units. Here every work position of an assembler (there are seven in the shop) is organized as a technologically closed loop assembly module consisting of several rotary (elevating and

traversing) assembly stands, places to store parts and assembly units, mechanization facilities (including places for installing and connecting manual mechanized tools). The wide front and high rate of the assembler's work is provided by the simultaneous, multiposition assembly of several products and the possibility of changing the work density (for example, increase the number of workers per module to two or three) with a sharp change in the planned volumes of output of one or another hydraulic turbogenerator. The product assembly is done basically of complete assembly units (assembled and tested hydraulic units in a set, with valve apparatus is assembled) and are sent from the hydraulic units machines assembly shop to the shop for assembling hydraulic turbogenerators, while pumps, couplings, etc. are sent from the preparatory assembly units of the given shop.

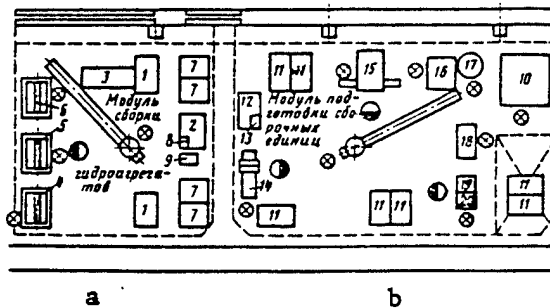

Fig. 2. a -- assembly bay for hydraulic turbogenerator units; b -- bay for preparation of assembly units.

The hydraulic turbogenerator shop has an area of 1100m² (with a test and correction section) and is serviced by 26 workers; the annual output is 16 models of 7700 products.

Fig. 2 shows a part of the hydraulic turbogenerator shop -- the section (module) of assembly units and the module (work position) to assemble hydraulic turbogenerators of the open (built-in type models 93P32V and 21P31V, where 1, 7, 10 and 11 are storage places (racks, special stands, vertical elevator warehouse); 2, 12 and 20 are fitter work benches; 3 is shelving; 4, 5 and 6 rotary assembly stands; 8 and 13 are mechanized equipment; a portable stand for tools; 14, 15 and 16 are drilling and grinding machine tools and press; 17 -- industrial vacuum cleaner; 18 -- machine tool for cutting, bending and rolling copper tubes; 19 -- heater. The assembled products are sent to a storage device and from there by a transport conveyor to the test section.

The creation of the GSSP provides high productivity of the assembly workers and flexibility of production, i.e., either none or a small volume of readjustments of production when the quantity and product list change.

COPYRIGHT: Izdatel'stvo "Mashinostroyeniye", "Mashinostroitel'", 1984

2291

CSO: 1823/318

ROBOTICS

UDC 621.9.06-236.58

TECHNICAL FEATURES OF ROBOTIZED MACHINING SYSTEM VIEWED

Moscow MASHINOSTROITEL' in Russian No 4, Apr 84 p 17

[Article by V. I. Kokin, O. V. Chalov, V. V. Balaburdin, engineers: "Robot Technical Complex"]

[Text] A technical robot complex (RTK) was introduced using a model 16K20F355 NC turning machine tool and model "Brig-10B" industrial robot. Additionally, there were designed and manufactured: storage-loader device to store the intermediate products and a storage-unloader device to receive and store finished parts, a grip device; and the operation of the electrical circuits of the robot, machine tool and the NC system was coordinated.

The RTK was organized to manufacture fastening studs up to 200mm long with an up to M36 diameter threads. The design of the storage-loader device makes it possible to readjust the RTK rapidly from one size of stud to another.

Moreover, the possibility is envisioned of regulating the slope angle of the chute and the height of the storage devices.

The gripping of the intermediate product in the storage-loader device is done as follows: the gripping device in the open position enters the slot in the lower part of the chute and clamps the intermediate product. When the robot actuator rises, the intermediate product leaves the retaining tabs on the chute and the actuator moves away smoothly; the intermediate products remaining in the chute slide down to the freed position. The storage-loader device is ready to repeat the following cycle.

To improve the operation of the three-cam self-centering mechanized chuck with an electromechanical drive, a regulated stop is installed in it and the cams have a 5 millimeter layer of bronze fused to their surfaces in order to prevent the crushing of the thread on the machined studs when clamped in the chuck.

The design and principle of operation of the storage-unloading device is similar to that of the storage-loading device

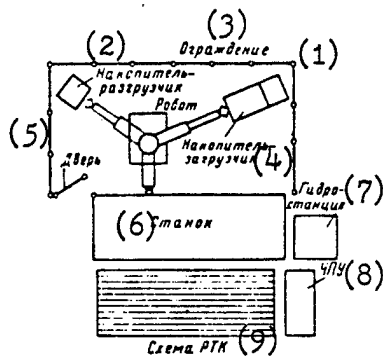

1 -- Robot; 2 -- storage-unloader device; 3 -- enclosure; 4 -- storage-loader device; 5 -- door; 6 -- machine tool; 7 -- hydraulic station; 8 -- NC; 9 -- RTK arrangement.

A three-cutter tool setup is used to increase the time of continuous operation of the RTK and reduce loss of time on readjustment. An additional set of tools or a device for the active monitoring of the geometrical parameters of the part being machined may be installed in the free positions on the six-position turret head of the machine tool. One set of cutters provides a two-shift continuous operation of the RTK. When the first set of cutters is out of action (broken or blunted tool), it is sufficient to change the program and the second set of tools will be used to machine parts. Moreover, cutters are used with non-regrindable, rapidly changed plates of cutting material that is highly durable at high machining modes. Along with a reduction in idle strokes of the tools and higher speeds, it was found possible to increase essentially the intensity of machining the parts.

The full operating cycle of the RTK is as follows. After preparing the industrial robot (PR), the machine tool and the NC system for operation (the robot is installed in the initial position, actuators of the machine tool in position "0"), the operator presses the "start" pushbutton on the PR control panel. The execution of the control program of the robot begins. The grip of the robot takes the intermediate product from the storage-loader device and places it in the chuck of the machine tool. An instruction is issued to move the tail spindle. This movement stops when the tail spindle touches the part. An instruction follows to clamp the part in the chuck. The robot returns to the initial position; "Start NC" instruction follows. The machine tool machines the part according to the control program in the first position. After machining is completed, the robot starts working again. Its grip clamps the part, the chuck opens and the tail spindle is moved away. The actuator turns the part 180° and the process of securing it is repeated.

The robot returns to its initial position and an instruction is sent to the NC system. Execution of the control program begins to machine the part in the

second position. After the part is machined and the actuators of the machine tool return to position "0", the robot carries the part to the storage-unloader device, from where it is dropped into packing. Then, the robot grips another intermediate product in the storage-loader part and puts it in the chuck. An instruction follows to the NC system. When the punched tape with the program reaches symbol "End program," it is reversed and set in its initial condition. The cycle is repeated.

The RTK control system fixes the following states of the complex: "tool in initial position;" "spindle stopped;" "back spindle moved up;" "back spindle moved away;" "part clamped;" "part unclamped." The absence of even one of these states in the process of the execution of the control program stops the entire complex. These states are selected for the safety of service personnel and to prevent accidents that may occur when the robot makes contact with the moving parts of the machine tool. The operating space of the RTK is enclosed by a fence.

The RTK introduction triples or quadruples the productivity of labor and improves the standard of production.

COPYRIGHT: Izdatel'stvo "Mashinostroyeniye", "Mashinostroitel'", 1984

2291

CSO: 1823/313

TECHNOLOGY PLANNING AND MANAGEMENT AUTOMATION

UDC 621.9.02.002.2:658.012.011.56

DECISION-MAKING PROCESS IN MANAGEMENT AUTOMATION

Moscow MASHINOSTROITEL' in Russian No 3, Mar 84 pp 38-40

[Article by Ye. I. Vorob'yev, director of the Moscow "Frezer" imeni Kalinin Cutting Tool Plant: "The Role of Management Decisions in Automatic Production Control Systems"]

[Text] All problems, such as improving the management of production-economic activity, raising operating standards in all economic links, orienting toward the achievement of the best production results by creating the most efficient management forms, are solved, to a certain degree, by increasing the validity of the decisions made by management.

Management, as a part of the total process of social production, is a special kind of activity, whose purpose is to pose clear statements of problems before each production collective and individual worker, to develop programs for solving these problems and to provide conditions for their implementation. Management processes lead, accompany and close production processes.

Components (resources, technology, output, etc.) originate in the management system in an ideal informational form which then materialize in production, i.e., the management processes lead the material production processes. It may be said that management accompanies material production, coordinating, regulating and stimulating the labor of the collective and completes the process of material production by monitoring and accounting for its results. The direct material process of manufacturing industrial products in combination with the management information process form the total production system.

At present, management is an independent, very complex and developed area of activity (a considerable number of workers in the national economy work in the management system); the cost of computers, organizational, peripheral and other types of management equipment has increased considerably and specialized industrial and interindustrial technical-economic information institutes were created, as well as specialized subdivisions at enterprises and in production associations.

The development of the management system was accompanied by the further specialization of subdivisions and individual workers in management, and the intensified communications between management subdivisions in one system and between high-level systems. Under these conditions, one of the deciding factors in developing the management system is its organization which consists of the systematic combination of all system components (labor, information which is the object and product of the management work and the technical means for management).

Management organization envisions the regulation of processes for making (reasons, preparation and adoption) and implementing management decisions; forming the structure of management bodies; determining the hierarchy and functional distribution of labor; regulating the working time of managers and specialists; and organizing their work. In this case, the leading role is played by the processes of making and implementing management decisions because to a considerable extent, they determine all remaining directions of organizing management work.

The organization of management is directed to producing the most favorable conditions for raising the prospects, validity and efficiency in the operation of the management body by achieving proportionality, continuity and regularity in all its links. Under modern conditions, work on organizing management has a multiplan nature and provides real comprehensive measures to develop and improve it.

The organization of managements includes a set of measures on tying management processes in with time, i.e., setting times for the processes of making and implementing decisions, planning, record keeping, monitoring, analyzing and regulating production. For this purpose, the activity of subdivisions and workers of the management body is regulated; a typical technology is developed and times are set for executing various kinds of work; time norms are determined for preparing documents and getting them to the executors, etc. Changes of purpose, in the conditions in the controlled object, methods of control in the environment of the controlled object and in the control technique make it necessary to develop the organization of management. Therefore, the problem of management organizers and production supervisors is to determine the time when quantitative changes in the conditions of production call for qualitative shifts that determine the requirements for these or other management decisions.

In individual production organizations and, particularly, at tool industry enterprises, the very content of management organization which, in some cases, is reduced to the management body structure, is treated in a very narrow manner. Actually, it includes the following: the processes of making and implementing management decision; the content, volume, methods and times for forming, transmitting and processing data; furnishing management bodies with modern equipment and insuring its efficient utilization; selection and placement of supervising cadres, specialists and service personnel; organization of management work.

The successful solution of these most important components of a comprehensive management organization can be achieved only by producing, functioning and

continuously developing automated systems for enterprise control (ASUP). The introduction of ASUP produces the necessary premises for making and implementing the most efficient management decisions; it increases the efficiency and quality of the operation of the management body; eases and accelerates the processes of forming, transmitting and processing of data, reducing thereby the labor-intensiveness of management work.

Frequently, in the practice of industrial enterprise activity in general and in the tool industry enterprises in particular, all work on organizing the ASUP is reduced basically to producing and utilizing computing and information centers (IVTs). Without doubt, the IVTs are an important link in the ASUP. However, it would be wrong to treat the ASUP only from the viewpoint of designing and operating the IVTs.

In our opinion, ASUP, functioning under a comprehensive management organization, must be directed toward establishing dynamic proportions between components and various links of the management body, and on maintaining correspondence between the structure and activity of the management body and the object of management. ASUP functioning also assumes an establishment of proportions between various subdivisions of the management body and the management system for a given object and its environment (higher ranking and related organizations, financial and credit organizations, procurement and marketing bodies, etc.).

Investigations which have been carried out indicate that taking into account the hierarchic level, the ASUP functioning, from the standpoint of a comprehensive management organization, should provide the following to the production collective manager:

qualitative correspondence and quantitative proportionality between workers of various categories, management personnel, trades and qualification levels, which must be met by the methods and management processes being designed;

proportionality between qualitative and quantitative composition of workers, information service and management techniques; correspondence between management system parameters and the condition and development trends and goals of the management object; correspondence between the hierarchic division of labor in the management body and the area of competence of workers at respective levels, i.e., their having the proper skills, knowledge, competence, interest and responsibility;

correspondence between functional division of labor and the content of the functions, subfunctions and work envisioned by the management process;

correspondence between the time of process management and the speed of execution of the production processes regulated and monitored in the management process;

correspondence between the productivity of various subdivisions of the management body and the objective proportions that determine the content and labor-intensiveness of various operations in the management cycle;

proportionality of interaction among all interrelated management subdivisions.

These directions of ASUP, functioning in a comprehensive management organization, are basic from the viewpoint of a production collective manager. However, there are also particular ones that must be implemented in designing processes of a comprehensive management organization, because the lack of their proper record may violate the system of organizational-economic and social management.

The achievement of these directions can be provided only by timely and high-grade decision-making and implementing processes.

As is well known, functional interrelated subsystems are singled out in the ASUP structure. There are different viewpoints on the question of the place of management decisions in the ASUP: some people consider management decisions a component part of the functional ASUP subsystems, while others -- of the software subsystems; still others do not refer to them either as functional or software subsystems which to us appears not entirely valid.

In our opinion, management decisions are formed and utilized on the boundary between functional and software subsystems. This is related to the fact that, first, they are directed to decisions on specific production problems along various functional subsystems; secondly, to make and implement them, output data is necessary, especially an information software subsystem. Thus, the process of making and implementing management decisions, functional and software ASUP subsystems are required. Their arrangement in the ASUP is shown in the Figure. As shown in the arrangement, management decisions are made in management bodies and are implemented in the controlled objects. In this case, they appear as direct communications while, as a result of implementation, they will appear as feedback by management bodies and controlled objects.

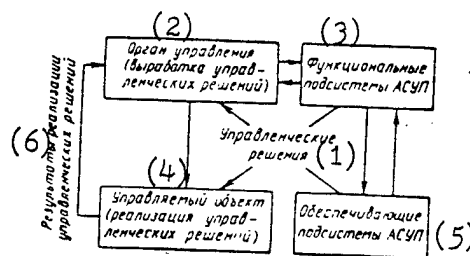

Figure

1 -- Management decisions; 2 -- Management body (making management decisions); 3 -- Functional ASUP subsystems; 4 -- Controlled object; 5 -- Software ASUP subsystems; 6 -- Results of implementation of management decisions.

The essential role of management decisions in the ASUP is that it spans all areas of enterprise functioning: scientific-technological, production, economic and social. Along the scientific-technological line, management decisions are directed toward accelerating the scientific-technological progress and toward constant improvement and renovation of the output; along the production line -- to satisfy quantitatively and qualitatively the requirements of the national economy in the finished products; along the economic line -- to insure national economic efficiency of enterprise activity; along the social line -- to satisfy most fully the material and spiritual requirements of the enterprise collective. Thus, it spans all components of the production management system -- goal and structure, methods, functions, technical facilities and technology, as well as the training of management personnel.

The role and content of management decisions are determined primarily at the management level. The Moscow "Frezer" Plant has three production management levels: highest, medium and lowest.

The highest management level (director, deputy director, chief engineer) is oriented toward making decisions on strategic, social-economic and scientific-technological problems; the middle level (managers of functional services) is oriented toward making decisions on current problems of preparation, organization and coordination of the production-economic activity and on insuring its efficiency and quality; the lowest level (chiefs of shops and sections, brigade foremen) are oriented toward making operational decisions on problems related to the organization of production and monitoring its implementation. Quantitative and qualitative indicators of reaching goals at the foundation of the economic management mechanism are determined on the basis of the hierarchic system.

Management is implemented by making and realizing diverse decisions that have considerable effect on the efficiency of production. The decision process assumes its validity, proper preparation, adoption and implementation.

With all the avenues of approach to investigating the processes of making and implementing management decisions in the ASUP, three basic aspects may be separated out: the cybernetic, based on the concept of decision making as data processing; organizational, consisting of identifying the interrelated sequence of individual and group actions; psychological, consisting of considering the decision making process as one of the thinking and psychological activity of people.

The following basic phases are characteristic for making and implementing management decisions: determination of goals; identification and analysis of problems; generation and analysis of alternatives; selection and implementation of decision; evaluation of execution. It should be noted that for the sequential realization of these phases, it is necessary to have, first of all, analytical data processed and combined in a certain manner. Management personnel spend considerable time on this work. Thus, investigations show that upper level management spends about 80 percent of its time processing data, the middle level -- over 92 percent and the lowest level -- about 65 percent of their time.

Strengthening the role of management decisions in the ASUP, the high scientific level of management and validity of the decisions being made assume a comprehensive development and expansion of analytical work at enterprises. The importance of the economic analysis of production activity as a basis for making management decisions consists in that it makes it possible to identify reserves for increasing the efficiency of production; improving socialist production relationships; controlling the production mechanism, planning and monitoring. It is also a means for communist training of workers, inculcating a thrifty attitude toward public property and attracting a wide mass to production management.

Analysis should occupy a special place in management control as a stage preceding the making of decisions. This is due to the fact that analytical data must be fairly complete and used soundly for all other management functions. The greatest efficiency of analytical work may be achieved only when managers and economic services can utilize, at any management level, economic analysis methods for the following: preparing scientifically valid plans; monitoring their implementation and efficient regulation of production; eliminating bottlenecks in developing production; identifying and mobilizing internal reserves; objectively evaluating cost accounting activity and results of socialist competition; and substantiating economic incentives for production collectives.

COPYRIGHT: Izdatel'stvo "Mashinostroyeniye", "Mashinostroitel'", 1984

2291

CSO: 1823/319

END