

# **BUILDING A TACTICAL INTELLIGENCE MODEL FOR THE INFORMATION- BASED FORCE**

**A MONOGRAPH  
BY  
Major Thomas H. Felts  
Military Intelligence**



**School of Advanced Military Studies  
United States Army Command and General Staff  
College  
Fort Leavenworth, Kansas**

**First Term AY 97-98**

Approved for Public Release Distribution is Unlimited

19980324 126

DTIC QUALITY INSPECTED 3

# REPORT DOCUMENTATION PAGE

Form Approved  
OMB No. 0704-0188

Public reporting burden for this collection of information is estimated to average 1 hour per response, including the time for reviewing instructions, searching existing data sources, gathering and maintaining the data needed, and completing and reviewing the collection of information. Send comments regarding this burden estimate or any other aspect of this collection of information, including suggestions for reducing this burden, to Washington Headquarters Services, Directorate for Information Operations and Reports, 1215 Jefferson Davis Highway, Suite 1204, Arlington, VA 22202-4302, and to the Office of Management and Budget, Paperwork Reduction Project (0704-0188), Washington, DC 20503.

1. AGENCY USE ONLY (Leave blank)

2. REPORT DATE  
18 December 1997

3. REPORT TYPE AND DATES COVERED  
MONOGRAPH

4. TITLE AND SUBTITLE

**BUILDING A TACTICAL INTELLIGENCE MODEL FOR THE INFORMATION-BASED FORCE**

5. FUNDING NUMBERS

6. AUTHOR(S)

**MAJOR THOMAS H. FELTS, MILITARY INTELLIGENCE**

7. PERFORMING ORGANIZATION NAME(S) AND ADDRESS(ES)

SCHOOL OF ADVANCED MILITARY STUDIES  
COMMAND AND GENERAL STAFF COLLEGE  
FORT LEAVENWORTH, KANSAS 66027

8. PERFORMING ORGANIZATION REPORT NUMBER

9. SPONSORING / MONITORING AGENCY NAME(S) AND ADDRESS(ES)

COMMAND AND GENERAL STAFF COLLEGE  
FORT LEAVENWORTH, KANSAS 66027

10. SPONSORING / MONITORING AGENCY REPORT NUMBER

11. SUPPLEMENTARY NOTES

12a. DISTRIBUTION / AVAILABILITY STATEMENT

DISTRIBUTION UNLIMITED

12b. DISTRIBUTION CODE

13. ABSTRACT (Maximum 200 words)

SEE ATTACHED

14. SUBJECT TERMS

**TACTICAL, INTELLIGENCE, FORCE XXI DIVISION INTELLIGENCE COMMAND, DIVINT, CHIEF OF RECONNAISSANCE TROOPS, CRT, INFORMATION WARFARE, G2, MI BATTALION COMMANDER, RLI, COMBAT POWER**

15. NUMBER OF PAGES

81

16. PRICE CODE

17. SECURITY CLASSIFICATION OF REPORT

UNCLASSIFIED

18. SECURITY CLASSIFICATION OF THIS PAGE

UNCLASSIFIED

19. SECURITY CLASSIFICATION OF ABSTRACT

UNCLASSIFIED

20. LIMITATION OF ABSTRACT

UNLIMITED

## ABSTRACT

**BUILDING A TACTICAL INTELLIGENCE MODEL FOR THE INFORMATION-BASED FORCE** by MAJ Thomas H. Felts, USA, 47 pages.

Force development trends since the end of the Cold War have dictated a smaller, more lethal force that is capable of rapidly responding to a multitude of contingencies from a CONUS base - force projection. The tremendous growth in information and precision technologies has established the technological conditions for this force development - information based. These requirements call into question the adequacy of current organizational structures and their ability to allow for the optimization of these capabilities to meet the needs of a force projection, information based Army. This paper examines the division level military intelligence model in particular. The division continues to be the major tactical formation with the capability to tailor for specific missions. Military intelligence, by definition, provides at least half of the information equation that the commander uses to make decisions.

The monograph will begin by charting the historical development of the current tactical MI organizational model based on the requirements for military intelligence contained in historical documentation and doctrinal developments since World War II. The monograph develops historical trends in the use of military intelligence. It then applies these trends as the baseline for developing and validating the criteria for evaluating the acceptability and suitability of the current model. These criteria also provide a template of requirements for consideration of alternative organizational structures. The monograph will then focus on two alternative organizational models for tactical military intelligence. The first of these, the Division Intelligence Command, will be built on the historical Division Artillery evolutionary example of building centralized command and control mechanisms to optimize the use of emerging technological capabilities. The second organizational construct is the Soviet model for the Chief of Reconnaissance Troops, and the Reconnaissance, Surveillance, and Target Acquisition Tactical Operations Center.

The monograph will conclude by evaluating the alternative models for tactical intelligence using the aforementioned criteria to determine the most suitable organizational model.

SCHOOL OF ADVANCED MILITARY STUDIES

MONOGRAPH APPROVAL

Major Thomas H. Felts

Title of Monograph: *Building a Tactical Intelligence Model For The Information-Based Force*

Approved by:

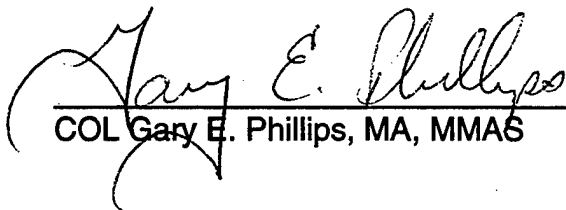

COL Gary E. Phillips, MA, MMAS

Monograph Director

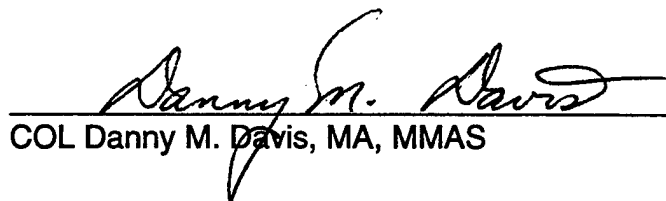

COL Danny M. Davis, MA, MMAS

Director, School of Advanced  
Military Studies

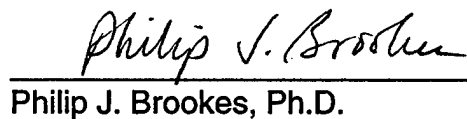

Philip J. Brookes, Ph.D.

Director, Graduate Degree  
Program

Accepted this 18th Day of December 1997

## ABSTRACT

BUILDING A TACTICAL INTELLIGENCE MODEL FOR THE INFORMATION-BASED FORCE by MAJ Thomas H. Felts, USA, 47 pages.

Force development trends since the end of the Cold War have dictated a smaller, more lethal force that is capable of rapidly responding to a multitude of contingencies from a CONUS base - force projection. The tremendous growth in information and precision technologies has established the technological conditions for this force development - information based. These requirements call into question the adequacy of current organizational structures and their ability to allow for the optimization of these capabilities to meet the needs of a force projection, information based Army. This paper examines the division level military intelligence model in particular. The division continues to be the major tactical formation with the capability to tailor for specific missions. Military intelligence, by definition, provides at least half of the information equation that the commander uses to make decisions.

The monograph will begin by charting the historical development of the current tactical MI organizational model based on the requirements for military intelligence contained in historical documentation and doctrinal developments since World War II. The monograph develops historical trends in the use of military intelligence. It then applies these trends as the baseline for developing and validating the criteria for evaluating the acceptability and suitability of the current model. These criteria also provide a template of requirements for consideration of alternative organizational structures. The monograph will then focus on two alternative organizational models for tactical military intelligence. The first of these, the Division Intelligence Command, will be built on the historical Division Artillery evolutionary example of building centralized command and control mechanisms to optimize the use of emerging technological capabilities. The second organizational construct is the Soviet model for the Chief of Reconnaissance Troops, and the Reconnaissance, Surveillance, and Target Acquisition Tactical Operations Center.

The monograph will conclude by evaluating the alternative models for tactical intelligence using the aforementioned criteria to determine the most suitable organizational model.

## TABLE OF CONTENTS

	Page
I. Introduction.....	1
II. The Origins of Current Organization and Associated Historical Trends.....	4
World War II.....	4
Korea.....	6
Vietnam Era.....	6
Post-Vietnam: Toward AirLand Battle.....	8
Toward the Future.....	10
III. Translating History into Trends and Methodology.....	11
The Tendency for Commanders to Want More.....	11
The Tendency Toward Information as Combat Power.....	13
The Tendency to Diminish MI During Peacetime.....	14
From Trends to Methodology.....	17
IV. Considering the Options: Indictment of the Present.....	21
Considering the Current Model.....	21
Unity of Command.....	22
Simplicity.....	25
Future Battle.....	27
Indictment of the Current Model.....	27
V. Considering the Options: Alternatives for the Future.....	29
The Division Intelligence Command.....	30
The Chief of Reconnaissance Troops.....	37
VI. Evaluation of Alternatives.....	41
Always Engaged.....	41
Downwardly Focused.....	42
Simultaneously Supported.....	42
Coverage Enhanced.....	43
Skip-Echelon Flexibility.....	43
Organizations Redesigned and Disciplined Operations.....	44
Synthesis and Overall Evaluation.....	44
VII. Conclusions.....	45
Endnotes.....	48

## Bibliography

### Appendices

1. Field Army Military Intelligence Battalion
2. Army Security Agency Support at Field Army
3. Initial TARS - 75 Battalion Organization Recommendation
4. Final TARS - Recommendations: Combat Intelligence Battalion
5. Division Combat Intelligence Company
6. Intelligence Organization and Stationing Study Final Recommendation
7. Division 86 CEWI Battalion
8. A-Series Division MI Battalion
9. The Relative Combat Power Model
10. The Relative Information Based Combat Power Model
11. The Information Effect on the Relative Combat power Model
12. F-Series Division MI Battalion
13. Division Intelligence Command
14. Chief of Reconnaissance Troops

## **I. Introduction**

The more critical step is to make the complete transformation to an information-based army. Such a transition requires that we make fundamental changes in how we gather, analyze, distribute, and act on information. from Force XXI - America's Army of the XXIst Century<sup>1</sup>

General Gordon R. Sullivan, in his reflections on the information overmatch achieved by the United States and its allies during Operation Desert Storm, sparked the intellectual flame for truly re-defining the battlefield. He admonished the Army to “develop a combat power model that allows it to win the battlefield information war, as an integral element of its operations.”<sup>2</sup> His admonishment has translated into the conceptual models for developing Force XXI, Army 2010, and the Army After Next. This admonishment is particularly salient for military intelligence. The current division organization for conducting tactical intelligence systemically hampers the commander’s ability to leverage relevant information and intelligence (RII), one of the three components of information operations as defined by FM 100-6. This doctrine defines operations, RII, and information systems as the components of information operations. Within the framework of RII, “intelligence, the commander’s source of relevant information about the enemy, takes on increased, even crucial importance.”<sup>3</sup> Given this level of emphasis on intelligence in the information age, the Army’s current divisional military intelligence (MI) organizational model fails to meet the organizational parameters for information-based operations as defined in TRADOC Pamphlet 525-5, Force XXI Operations.<sup>4</sup> It specifically lacks the organically required features of an information-based, force-projection intelligence organization as identified in FM 34-1,

### Intelligence and Electronic Warfare Operations:

- always engaged
- downwardly focused
- simultaneously supported
- coverage enhanced
- skip-echelon flexibility
- organization redesign
- disciplined operations.<sup>5</sup>

The net effect of this lack of capabilities is the introduction of greater complexity into tactical intelligence operations, and a diminished common understanding of the battlefield. The advent of information operations, coupled with the evolution of information as an element of combat power, signal the need for us to reconsider the effectiveness of our current model for conducting tactical military intelligence.

This monograph will attempt to evaluate the acceptability, suitability and effectiveness of the current division-level MI organizational model given the existing and emerging requirements for tactical intelligence. The monograph will use a baseline of criteria to determine the acceptability of the current model, and to compare the suitability and effectiveness of alternative organizational solutions in order to determine the one best suited to the information-age battlefield. The screening criteria for consideration of an intelligence organization will be unity of command and simplicity (principles of war described in FM 100-5, Operations). Evaluation criteria for measuring the effectiveness of the current intelligence organization vice alternative solutions will be the aforementioned features of force projection intelligence. These criteria describe those features of intelligence that are the critical enablers of relevant, timely, accurate, predictive intelligence in an information-based, force-projection intelligence

organization.<sup>6</sup> Each of these features will be discussed in further detail in the method and evaluation portions of the monograph.

The monograph will begin by charting the historical development of the current tactical MI organizational model based on the requirements for MI contained in historical documentation and doctrinal developments. An evaluation of the current model given the aforementioned criteria and the emerging requirements and concepts for tactical MI will provide the basis for considering alternative organizational solutions. The monograph will then focus on two alternative organizational models for tactical MI.

The first of these, the Division Intelligence Command (DIVINT) will be built on the historical Division Artillery (DIVARTY) evolutionary example of building centralized command and control mechanisms to optimize the use of emerging technological capabilities. The historical emergence of this force-multiplying organization in light of critical developments in technology provides excellent parallels to the idea of command advocacy for emerging information capabilities, especially in light of the concept of information as combat power.

The second organizational construct is the Soviet model for the Chief of Reconnaissance Troops (CRT), and the Reconnaissance, Surveillance, and Target Acquisition (RSTA) Tactical Operations Center (TOC). FM 100-2-series Soviet threat manuals and historical accounts of Soviet tactical intelligence provide a conceptual template for the CRT as a command and control mechanism for tactical intelligence operations and unity of intelligence effort.

The monograph will conclude by evaluating the alternative models for tactical

intelligence using the aforementioned criteria to determine the most suitable organizational model.

## **II. The Origins of Current Organization and Associated Historical Trends**

“This operation proved that the Army’s investment in intelligence over the years was worth the cost.”

BG John F. Stewart, Jr.  
G2, 3rd U.S. Army  
Riyadh, Saudi Arabia  
27 April 1991<sup>7</sup>

The emergence of military intelligence as a force multiplier can only be understood in the context of key historical events and trends associated with this intrinsically information-intensive craft. This chapter will detail the events, leaving trends analysis for the next chapter as a means of analyzing current capabilities. These trends are best established by looking at the growth of the MI field since World War II (WWII). That is the first conflict in which industrial-age communications means (and associated informational implications) were widely used by all belligerents.

### **World War II**

The McNair triangular division was the means to concentrate a maximum of men and materials in offensive striking units capable of destroying the enemy’s capacity for resistance. Intelligence was a “pooled” capability, especially in the technical fields - what a unit needed only occasionally should be held in a reserve pool under higher headquarters.<sup>8</sup> Army leaders would later reflect on the initial lack of support in the hands of field commanders. In light of his understanding of history, General Marshall noted the deficiencies in intelligence: “prior to WWII, our foreign intelligence was little more than what a military attaché would learn at dinner, more or less over a cup of coffee.”<sup>9</sup>

General Eisenhower, in his book Crusade in Europe, noted many deficiencies that existed

in the organization and function of intelligence before WWII - caused by lack of support by senior officers and civilians between the wars and subsequent inadequate funding for Army intelligence.<sup>10</sup> General Omar Bradley summarized the problem succinctly.

“The American Army’s long neglect of intelligence training was soon reflected by the ineptness of our initial undertakings. For too many years in the preparation of officers for command assignments, we had overlooked the need for specialization in such activities as intelligence...in some stations, the G2 became the dumping ground for officers ill-suited for command. I recall how scrupulously I avoided the branding that came with an intelligence assignment in my own career. Had it not been for the uniquely qualified reservists who so capably filled so many of our intelligence jobs throughout the war, the Army would have been pressed.  
11

Fortunately, many commanders and their G2s quickly organized an effective intelligence organization to support the planning and execution of the war. Major General Sir Kenneth Strong was General Eisenhower’s intelligence chief. In his book, Intelligence at the Top, he notes that the intelligence organization supporting General Eisenhower was “a superb operational intelligence staff...the intelligence organization that supported the preparation and execution of the Normandy invasion was perhaps the best ever assembled.”<sup>12</sup> In his book G2: Intelligence for Patton, General Koch states, “In Patton’s commands, intelligence was always viewed as big business and treated accordingly.”<sup>13</sup> In the time that it took to fight World War II, a system was created that kept field commanders, their superiors at theater, the War Department, and ultimately the president, constantly informed of a broad spectrum of intelligence collected by every available means. WWII promoted the professionalism of the military intelligence community, and validated a requirement for knowledgeable intelligence officers serving as G2s and S2s of tactical units supported by trained MI specialists.”<sup>14</sup>

## Korea

The gains from WWII would be short lived, however. Post-WWII demobilization would seriously reduce the Army's ability to later provide quality intelligence support in Korea. Tactical intelligence capabilities, in particular, were quickly dissipated.<sup>15</sup> Once again, the pressing needs of a real shooting war were required to regain emphasis on a robust intelligence capability. This emphasis, however, would not come in time to save U.S. Forces from one of the greatest failures of intelligence - the failure to anticipate the Korean invasion. General Matthew Ridgway voiced the level of frustration best:

“How could anyone have read this report and not anticipated an attack is hard to fathom. Yet this report was not used as the basis for any conclusion by G2 at General Headquarters in Tokyo and it was forwarded to Washington in routine fashion, with no indication of urgency”<sup>16</sup>

The positive outgrowth of the Korean war, however, was the recognition of the need to establish training and branch management for MI professionals. Also, although no standard organization was in place, most units had on hand intelligence specialists of various disciplines; for example, the Army Security Agency (ASA), which would provide tactical signals intelligence.<sup>17</sup>

## Vietnam Era

The Tactical Reconnaissance-Surveillance 1975 (TARS-75) Study conducted during the Vietnam War would be the first acknowledgment of the need to consolidate organic, multi-disciplined intelligence capabilities with the division commander.<sup>18</sup> Prior to TARS-75, appropriate assets existed within the total Army force structure to provide tactical intelligence support (see Appendix 1, Field Army MI Battalion, and Appendix 2, Army Security Agency Support at Field Army). The problem was putting

them at the disposal of the tactical commander when he needed them most. The perceived compartmentalization and redundancy inherent in this organization served to alienate an entire generation of Army leadership. The high percentage of reserve MI force structure contributed to this problem.<sup>19</sup> The TARS-75 recommendations included the establishment of a MI Battalion and associated communications organic at division, thus "ensuring the free and rapid flow of vital intelligence information from collector to consumer."<sup>20</sup> (see Appendix 3, 4, TARS - 75 Recommendations) Fiscal constraints, however, would preclude implementation of the TARS-75 recommendations. The Army would opt instead to form a Combat Intelligence Company (see Appendix 5, Division Combat Intelligence Company). The crucible of real conflict would once again be required to amplify the need for solid tactical intelligence.

The next opportunity to gain experience under fire would not fall directly to U.S. forces. The 1973 Middle East War would help the U.S. Army realize that it could no longer afford the expense and duplication of effort represented by the numerous different intelligence commands and corresponding intelligence infrastructure which it had created. Tactical doctrine and battlefield lethality had changed dramatically since WWII; with the advent of modern weapons, intelligence organization still largely reflected it's WWII model. As a result, in December 1974 the Army Chief of Staff directed the Intelligence Organization and Stationing Study (IOSS), or Ursano Study. IOSS would consolidate and integrate all military intelligence and electronic warfare functions so that each division and corps would have it's own organic Combat Electronic Warfare Intelligence (CEWI) unit.<sup>21</sup> (Appendix 6, IOSS Recommendation)

## Post-Vietnam: Toward AirLand Battle

Division 86 would be the culmination of the effort to institutionalize tactical military intelligence. The 1977 Battlefield Development Plan was the basis of Division 86 organization. The concurrently developed doctrine was AirLand Battle. Both were designed to maximize the modern capabilities demonstrated in the 73 Arab-Israeli War. Under Division 86, the Army would fully implement CEWI,<sup>22</sup> bringing the effectiveness of tactical intelligence and electronic warfare (IEW) to its historical peak, where it has largely remained (organizationally speaking) until today (Appendix 7, Division 86 CEWI Battalion). This force structure of approximately 455 soldiers has dropped somewhat on the current A-Series TOE. (Appendix 8 , A-Series Division MI Battalion). Doctrine, training, technology, and guiding principles of employment, however, continued to mature.

Desert Shield/Storm provided the next crucible to test how right we had gotten the MI force structure. As General McNair had so aptly insisted during WWII, “The only final test of military organization, as of training and equipment, was combat.”<sup>23</sup> BG John Stewart, the 3D U.S. Army G2, would be the senior Army intelligence officer during this conflict. As the future Commander of the U.S. Army Intelligence Center he would incorporate the lessons learned into updated capstone doctrine for MI. In his hotwash entitled Operation Desert Storm: the Military Intelligence Story, Stewart’s reflections show that this conflict was a two-edged sword with regard to MI performance. On the one side, he reflected that “Military Intelligence came of age here in the desert. MI stood up as a battlefield operating system co-equal with all others.”<sup>24</sup> This was further

amplified in the key elements of MI's success in the desert that appeared throughout the text of his MI Story: tactical focus, superb training, and the leverage of IEW technology - to include communications, computer downlinks, and data processing capabilities.<sup>25</sup> On the other side, he reflected that "our challenge now is to modernize and institutionalize what we used and what we learned here."<sup>26</sup> This was further amplified by the major challenges in the desert that appeared throughout the MI Story: building trust with commanders, providing adequate linguist support, developing and fielding an IEW architecture, and building an ARCENT G2 and Army MI team.<sup>27</sup> Clearly, the top down integration of military intelligence capabilities was foremost in his mind. The technological capabilities ultimately made available to the MI force, however, had outstripped the systemic capability to harness them. In the words of BG(R) Huba Was de Czege (in discussion of developing future force structures),

It is within our (physical) capabilities to focus combat power decisively with information and precision. It is currently beyond our (cognitive) capability, however, to conceptualize and organize for this non-linear battlefield as an institution."<sup>28</sup>

In spite of the institutional inertia to harnessing intelligence capabilities, the omnipresent nature of effective intelligence support down to the lowest levels, in high-grain detail, was unprecedented. This was the birth of the precepts leading to the features of force projection, information based intelligence contained in our current FM 34-1. This also signaled the serious consideration of information as combat power. Stewart, in analyzing and incorporating the lessons of the Desert in FM 34-1, would summarize the MI of his historical experience in these words:

"Over the last 20 years....MI has become integral to combat organizations...by eliminating "stovepipes" and breaking down the "Green

Door.” We created multi-disciplined MI...at (all) levels oriented toward support to commanders. We created leaders..soldiers who are technically/tactically proficient in focusing (the intelligence battlefield operating system) on commanders who lead soldiers into combat. This effort came to fruition during Operations Desert Shield and Desert Storm.<sup>29</sup>

### **Toward the Future**

A final historical punctuation mark is the ultimate maturation of the widely accepted relative combat power model developed by Huba Was de Czege in 1984 (see Appendix 9, The Relative Combat Power Model). In his monograph entitled Information - the Fifth Element of Combat Power, MAJ George Franz expands the relative combat power model to include information effect - as a separate, distinct element of combat power (see Appendix 10, The Information Based Relative Combat Power Model, and Appendix 11, Information Effect). Doctrinal and conceptual outgrowths in FM 100-6, Information Operations, TRADOC Pamphlet 525-5, Force XXI Operations, and Army Vision 2010, validate Franz’s model, and set the stage for discussing emerging needs - specifically information dominance as a pattern of operations.<sup>30</sup> Our information operations doctrine specifically focuses on the overall build of relative combat power:

Information operations do not offer any panaceas. Perfect knowledge is not the objective. The military objective remains - to enter an operational theater capable of achieving superior relative combat power against an enemy, or to establish situational dominance in operations other than war.....Such integration (of information, INFOSYS, and their effects across a full range of military operations) enables and enhances the elements of combat power.”<sup>31</sup>

### **III. Translating History Into Trends and Methodology**

It is a popular comment that every war is different from the last. Actually, a survey of the whole course of military history brings out, as a dominant fact, the remarkably gradual evolution of military methods, and the slight difference of technique between one war and the next. Rarely do we find that even the contemporary experience of one war has been applied to the structure and tactics of armies when the next war overtakes them, sweeping them up like driftwood on a flood. Still more rarely has anyone taken time by the forelock and ensured victory by anticipating *the trend of warfare*.

B.H. Liddell Hart  
"Armament and its Future Use"  
1930<sup>32</sup>

The preceding view of the recent history of tactical military intelligence shows three distinct trends:

- The tendency for commanders to want more vice less when it comes to intelligence in conflict.
- The tendency - doctrinally, conceptually, and practically - to elevate information to a component of combat power, especially since WWII.
- The historical tendency to diminish MI force structure and scope during peacetime.

#### **The Tendency for Commanders to Want More**

From Marshall to Patton in WWII, to Ridgway in Korea, through the Ursano study, and culminating with Stewart's validation of the tactical focus of MI in Desert Storm (provided by an MI architecture built on the fly), tactical commanders strongly desire a viable intelligence mechanism, in-hand, that supports them when the shooting starts. One MI battalion commander described the (maneuver) commander's "thirst" for imagery: "The bottom line in this commander's eyes was that the addition of imagery (a particularly lucrative sensor capability in the desert environment, given the open terrain

and easily distinguishable adversaries) adds credibility to other intelligence sources.” At the same time, this MI operator noted the frustration of trying to move this critical information across a limited MSE network that required up to 40 minutes for the transmission of a single image.<sup>33</sup> This particular real-world vignette is indicative of the trend to gain a higher granularity of detail in the intelligence picture, and to have it delivered, as BG Stewart often stated, “on time, every time, wherever I (the commander) am.”<sup>34</sup>

This particular trend is really not new. Van Creveld describes the “history of command in war” as “an endless quest for certainty.”<sup>35</sup> In any given adversarial environment, the enemy will constitute at least half of this equation, so it stands to reason that commanders will be faced with the perennial need to ascertain what the enemy can do or will try to do. The difference in the present slice of history lies in the growing set of information technologies that have permeated the entire fabric of our society, including the military. James Beniger documents this trend in our society at large. He notes the growth of an “information society” in response to the “control revolution.” The control revolution is a response to the problems arising out of advanced industrialization - specifically, the need to have information feedback mechanisms in place to regulate industrial production, distribution, and consumption.<sup>36</sup> WWII provided an operational environment that signaled the culmination of industrial-based warfare<sup>37</sup> and the advent of what we recognize as modern information-based warfare.<sup>38</sup> The Army has been struggling ever since with its own version of the control revolution - the need to have information feedback mechanisms in place to regulate the application of combat power.

Carl Builder, in his RAND study entitled The Masks of War, makes the next step in logic based on his view of this trend:

“Conflicts requiring American military intervention are not likely to be winnable by means now configured for the main battle of Central Europe. For example, the greatest contribution that the army might make in many third world conflicts would be to support indigenous forces with information in the form of surveillance, recon, intel, comms, and analysis through small, high-tech units. That, clearly, is a direction that would be vigorously resisted by the traditional combat arms branches. Yet, it is a direction that history, technology, and even common sense seem to commend.”<sup>39</sup>

Given the implications of this trend, the Army would do well to consider that, in each of the historical cases cited previously, the Army has asked its soldiers to in essence improvise a viable intelligence capability for tactical commanders. The ability to learn and adapt is an inherently soldierly quality, but it would be poor strategy to relegate future generations to this method of doing business, especially in light of the next historical trend.

### **The Tendency Toward Information as Combat Power**

From Desert Storm successes in leveraging IEW technology and Sullivan's seminal vision of an information-based force, through Franz' logical progression of Was de Czege's combat power model, culminating in information operations doctrine and concepts that describe information dominance, information has attained the level of combat power - a trend easily recognized and realized. Beniger solidifies this view with a description of the role of information in the information society relative to matter and energy (the other raw components of industrial production; and for our purposes, the raw components of combat power):

Information processing may be more difficult to appreciate than matter or

energy processing because information is *epiphenomenal*: it derives from the organization of the material world on which it is wholly dependent on for its existence. Despite being in this way a higher order or derivative of all matter and energy, information is no less critical to society. All living systems must process matter and energy to maintain themselves counter to entropy, the universal tendency of organization toward breakdown and randomization. Because control is necessary for such processing, and information, as we have seen, is essential to control, both information processing and communications, insofar as they distinguish living systems from the inorganic universe, might be said to define life itself...<sup>40</sup>

Indeed, FM 100-6, with its emphasis on information dominance, now treats information as something that is active in nature, like other elements of combat power. *It is done* to a potential adversary through building and protecting friendly information capabilities, while degrading that of the enemy. TRADOC Pamphlet 525-5, in describing future land operations, describes “the main imperative guiding future operations....will be to gain information and continued accurate and timely shared perceptions of the battlespace.”<sup>41</sup> The end state is friendly knowledge and understanding of the situation that is more certain than that of the enemy - information superiority.<sup>42</sup> Joint and Army doctrine even define three operational types that contribute primarily to gaining and maintaining information dominance: command and control warfare (C2W), civil affairs (CA), and public affairs (PA).<sup>43</sup> Relevant information and intelligence (RII) plays a decisive role in all three of these operational forms. Implicit in this concept is the notion that the traditional elements of combat power - fire, maneuver, protection, and leadership - *follow* information, the new element of combat power. Given the fiscal and strategic reality of a smaller force, that force must be more lethal, and it cannot afford (both literally and figuratively) to miss. Accurate, relevant, timely information - *particularly relevant information and intelligence about the enemy* - ensures that the force is on

target. Given this trend, the Army has the explicit charter in TRADOC Pamphlet 525-5 to organize to allow soldiers and leaders to optimize information-based battlefield capabilities.

### **The Tendency to Diminish MI During Peacetime**

From post-WWII to post-Korea, through Vietnam and the Cold War, and post-Cold War/Gulf War, the Army has shown a disturbing historical propensity to reduce (and, in some cases, eliminate) MI force structure during periods of perceived peace. This propensity has largely been a matter of design and convenience, given the nature of our larger warfighting organizational structure. This structure is still wedded in its origins to the McNair Triangular Division model of WWII, which used the “pooling” concept to concentrate and mass “special” capabilities at a higher headquarters. MI, like other pooled capabilities, was not considered a core requirement for the standing tactical force, and could be massed from reserves during peacetime as required.

Builder extends our understanding of this organizational model as a product of the very identity of the Army.

“The Army sees itself as the essential artisans of war, still divided into their traditional combat arms - the infantry, artillery, and cavalry (armor) - but forged by history and the nature of war into a mutually supportive brotherhood of guilds. The combat arms or branches are the guilds, associations of craftsmen who take the greatest pride in their skills. (These guilds are) joined in a brotherhood (because of) a common family bond (the Army), and recognition...of dependency upon each other in combat.”<sup>44</sup>

Hence, until the advent of the permanent CEWI battalion, MI would provide a regular source for force reductions. Even after CEWI, however, MI would have to continue justifying a tactical presence to skeptical senior army leadership groomed in the

art of war associated with the combat arms "guilds."<sup>45</sup> It would ultimately require the lessons of the Combat Training Centers (including both the maneuver training centers and the Battle Command Training Program) and their application in Just Cause, Desert Storm, and Haiti to convince the existing Army culture that information operations in general, and intelligence in particular, are crucial to success in any environment. As Was de Czege recently stated, "No mature commander debates the validity of intelligence in particular, and doesn't need this emphasis pushed on him, unless he's dumb."<sup>46</sup> So, why has the Army historically maintained status quo, or cut MI force structure? Some of this can be attributed to the myth of being able to do more with less, given enabling information technology.<sup>47</sup> This myth has become reality in the current A-Series and Force XXI (F-Series) TOE's (see Appendix 8, A-Series MI Battalion, and Appendix 12, F-Series MI Battalion), which show static or reduced intelligence structure compared to the Division 86 MI battalion.<sup>48</sup> Builder sums up the rational:

The Army, like most large institutions, is a captive of its own internal fiefdoms. The guilds of the Army - its branches - freeze the Army by their understandable desire in maintaining continuity and stability of internal power.....the other services are not trapped (by internal structures) in the same way as the Army...by the stable balance of power among its three traditional combat arms branches - infantry, artillery, and cavalry (now armor)."

In a practical sense, this trend manifests itself in the form of combat leadership with an insatiable appetite for accurate, timely, relevant, predictive intelligence - more so than any time in the history of our Army. This expectation is a natural outcome of an information-based force, and is a sign of the times. This expectation, however, is levied in an environment of relatively static (or shrinking) MI force structure. These

dichotomous priorities have led to what is currently a suboptimized intelligence structure. The triangular divisional concept and its associated pooling of special capabilities, in essence, lives on - in spite of the Force XXI charter to “organize around information processing and dissemination,” and to “organize around the division as the major tactical formation with the capability to tailor it for specific mission purposes.”<sup>49</sup> This is also in spite of the trend toward the information society noted by Beniger, where a larger proportion of civilian “organization” (represented by the labor force) is in information-related vocations.<sup>50</sup> The reality represented by the direction of our society and economy, and espoused in our military concepts (the talk) is, therefore, in a clash with the reality we as an institution build for ourselves in the force structure (the walk), where the real nature of the current institution comes out in how we spend our dollars.

### **From Trends to Methodology**

The preceding trends are the dynamics playing against one another to build the problem statement for MI at division level: Does the current tactical intelligence organization at division level provide effective intelligence support? If not, how do we define the need for the future? Finally, how might that future look? Answering these questions requires a definition of methodology within the contexts of

- the existing charter for making the vision of the information-based battlefield a reality, contained in TRADOC Pamphlet 525-5, Force XXI Operations.
- the requirements for tactical MI, best detailed in the features of military intelligence in an information based, force projection Army.<sup>51</sup>

The Force XXI organizational charter prescribes the following design parameters

for building the future Army.

- Design organizations that are rapidly tailorable.
- Organize around information processing and dissemination.
- Change leader-to-led ratio and build in flexibility for specific missions. Likewise, staffs may not be constant in size, but tailorable to the mission.
- Organize around the division as the major tactical formation with the capability to tailor it for specific mission purposes.
- Modularize combat and combat service support that is capable of task organizing for the mission.
- Capitalize on the full range of mission capabilities in the Total Force structure.<sup>52</sup>

These parameters serve to build toward a critical assumption, and screening criteria for consideration of any MI organizational solution. The focus on a division-based solution, coupled with the mandates to capitalize on the full range of mission capabilities and organize around information, leads to a critical assumption in the resource-constrained, “zero sum” environment of the Army: resources in the context of this study means the entire division force structure, *and resource priority will be given to that combination of the elements of combat power (to include information) that will best serve the force.* The focus on rapid tailorability, leader emphasis, flexibility, and task organization dictate the use of two particular screening criteria from the principles of war: unity of command (*for every objective, seek unity of command and unity of effort*), and simplicity (*prepare clear, uncomplicated plans and concise orders to ensure thorough understanding*).<sup>53</sup> The parameters contained in TRADOC Pamphlet 525-5, and

the associated assumption and screening criteria are the logical starting point for any discussion involving future MI organization. They serve to focus the “organizational adaptation” concomitant with any discussion of the Revolution in Military Affairs,<sup>54</sup> while building toward an organization for combat that seeks to reduce the internally inflicted “friction”<sup>55</sup> of disunity and complexity.

FM 34-1, Intelligence and Electronic Warfare Operations, by design, “provides a common, flexible framework of thought and expectations within which soldiers think about and debate the issues of our profession.”<sup>56</sup> As such, it incorporates as prescriptive requirements the following primary features of military intelligence in an information based, force projection Army.

- Always engaged - Collection, processing, analysis, and dissemination occurs in peacetime, and through the range of military operations. This requires assessment of each contingency to determine intelligence requirements and develop plans.<sup>57</sup> This feature re-defines force readiness in terms of MI (information) readiness.
- Downwardly focused - Intelligence should get to the subordinate commander, when requested, in a usable format, and focused on his echelon and battle space. Higher echelons “push” tailored intelligence support down, and facilitate the lower echelons’ “pull” of intelligence products, from bulk data to specific queries.
- Simultaneously supported - Provide commanders at multiple echelons with a common picture of the battlefield derived from national, joint, and Army collection assets.
- Coverage enhanced - See the width and depth of the battlefield at the highest, most

consistent level of resolution available. Focus on near-real-time and real-time capabilities with targeting accuracy, enabling the intelligence analyst to quickly synthesize information, and present the commander and staff an easily assimilated product.

- Skip-echelon flexibility - this idea compliments downward focus. Critical, perishable intelligence provided to the tactical commander from tactical, joint, and national capabilities is especially critical in the preparation and early-entry stages of force projection.
- Organizations redesigned - MI organizations are, or will be, redesigned to take advantage of technology and incorporate lessons learned.
- Disciplined operations - Adherence to laws, regulations, and policies to ensure disciplined operations in support of commanders.<sup>58</sup>

These features, built on the basis of current and emerging technological capabilities, and the concepts inherent in an information-based force, are the core criteria for what a military intelligence organization ought to be able to do. They are the necessary technical prerequisites to accomplishing the doctrinal MI tasks in an effective manner.<sup>59</sup> Beniger documents how “technology defines the limits on what a society *can* do; the features of intelligence, then, lend specific definition to what intelligence *can* do, and an evaluative tool for how well a given organizational structure *optimizes these capabilities* in the hands of our soldiers and leaders. That, after all, is the purpose of organization.

These prescriptive notions contained in current doctrine and concepts answer at

least one of the question previously posed - a view toward what a future MI organization ought to look like. This will be the requirement against which current and future MI organizations are considered.

#### **IV. Considering the Options: Indictment of the Present**

The evolution of methods is even slower (than technology) because any step forward is usually followed by a slip backward.....The army which first (has) the moral courage to scrap most of its old-style units and replace them.....would at once have an immense advantage over all others.

B.H. Liddel Hart  
“Armament and its Future Use”  
1930<sup>60</sup>

In the previous chapter, the connection of historical trends led to force requirements for MI as defined in concepts and doctrine. This point of departure allows us to consider the effectiveness of the current tactical intelligence organization at division level. It also gives us the template of requirements for defining how future intelligence organizations may look. The products of the last chapter – screening and evaluation criteria – provide the institutionalized “common sense” that Builder admonishes us to consider in The Masks of War. The screening criteria will measure acceptability, and the evaluation criteria will measure the degree of suitability of any acceptable alternatives.

#### **Considering the Current Model**

The following characteristics of the current division-level intelligence model relate directly to the screening criteria (unity of command, simplicity):

- The roles and responsibilities of the G2 and MI Battalion Commander.
- The ability of the model to allow for the efficient leverage of enabling technologies.

Given these characteristics the aforementioned screening criteria, the current tactical intelligence model is not acceptable.

The current model lacks unity of command and simplicity due to the traditional

yet outmoded and inherently flawed concept of a separate G2 and MI battalion Commander. Although this appears to be a broad statement, one must consider the lack of study concerning the evolution of this relationship, the uniqueness of this relationship (as compared to other staff and operator relationships), and its inherent complexity, given the requirements for an information-based, force projection organization.

### **Unity of Command**

There is no in-depth, documented study concerning the systemic friction caused by our current G2/MI battalion commander organizational structure. MG Sidney T. Weinstein, in his historical discussion of the TARS-75 recommendations, makes one of the few historical footnotes: although the concept of the Battlefield Information Control Center (BICC) was validated and widely accepted, “it was felt that the vertical intelligence structure originally recommended violated the basic principle of unity of command. Intelligence was and is a command prerogative, so it was decided that the BICC elements be made organic, not attached, and be added to the TOE’s at respective headquarters companies.”<sup>61</sup> Stewart, in his observations from Desert Storm, provides only one paragraph on the G2/MI Commander relationship.<sup>62</sup> The tremendous growth in the technological ability to move, mass and exploit information should give adequate cause to reflect on the roles of the G2 and MI battalion commander to see if this relationship has evolved to a level of redundancy; or possibly even inadequacy.<sup>63</sup>

Intelligence staffs have been a regular fixture of staff organization since the time of Napoleon. The G2 as a coordinating staff member in the American Army has its historical roots in the efforts Major Ralph Van Deman (head of the infant Military

Information Division, the War Department's first intelligence staff) just prior to and during WWI. Van Deman received authority from the Army Chief of Staff to "initiate a program of identifying and training qualified National Guard Officers for tactical intelligence work... to provide a nucleus of intelligence officers when mobilization occurred."<sup>64</sup> The G2 would eventually become a general staff officer on a par with his contemporaries – as was already the case in most European armies - and would be the "senior intelligence officer"(SIO). The concept of the SIO would arise primarily from the need to designate an officer in the organization accountable for special security programs, information, and working areas.<sup>65</sup> As a matter of convenience, the designation of the SIO has historically grown to include the staff supervision of the numerous redundant, external intelligence capabilities that may be called to support the commander. This trend found its birth, as have others that we still live with, in the "pooling" methodologies associated with the triangular division. Contributing to this was the fact that the preponderance of the MI force structure that could potentially support a division (until the implementation of CEWI) was external to the division.

This SIO moniker is unique among the other combat, combat support, and combat service support functionaries.<sup>66</sup> There is not, for instance, a "senior logistician" or a "senior engineer." These equivalent responsibilities are vested in the Division Support Commander, and the Division Engineer Commander, respectively. The dispersed nature of military intelligence capabilities prior to the advent of the MI battalion implicitly warranted the need for a staff advocate to ensure that the commander's intelligence needs were understood and met. The concept of the staff-based SIO, from an operational

standpoint, has outgrown its usefulness in the current organizational context. Its founders did not anticipate the advent of an organic divisional MI battalion, nor did they anticipate the growing role of information as an element of combat power.

Optimally, the G2 of a division, as the doctrinal SIO,<sup>67</sup> should be the ranking intelligence officer. The presence of two military intelligence lieutenant colonels on the division TOE, coupled with the propensity for competitive officers to assume both the G2 and MI battalion duty positions, and the challenges inherent in the officer management system, will often lead to the assignment of a G2 who is outranked by the MI battalion commander. MG Charles Thomas, Commander of the Army's Intelligence Center, when asked about the potential for problems in this environment, stated, "If we have these guys that can't get along, the commander will fire them... the days of being at odds are gone. If I (the MI proponent) know of this, they had better not come before a promotion board."<sup>68</sup> Compare this view with the reflections of an MI battalion S3 (attempting to make sense out of ACE doctrine and the fielding of ASAS): "We can relay information directly...and more expeditiously position the baseline (of ground signals intelligence assets). That in itself is good, yet the current G2 (and I know this from experience) believes there can only be a single assessment – his...Consequently, there is always a disconnect between the intel picture at the DMAIN and DTAC."<sup>69</sup> This comparison of perspectives serves to point out that, though our traditional organization seeks to establish unity of effort in conducting intelligence operations, there is confusion concerning who is in charge of the intelligence effort. More importantly, there is systemically inflicted confusion on where the true, correct intelligence picture comes

from.

This is not the fault of anyone who has served as a G2 or MI battalion commander. It is a systemic reality that the military intelligence community and the Army must come to terms with. Without a clear, systemic means of establishing the identity of the SIO, personalities, perceived levels of knowledge or experience, or the personality-driven preferences of the commander – any number of intangible, subjective factors – will creep into the equation.

### Simplicity

This traditional G2/MI commander relationship creates an inherently complex operating environment. FM 34-1 *repeatedly* refers to the *parallel* responsibilities of the G2 and MI battalion commander to update their plans and orders to reflect the evolving situation...and also update databases and graphics.<sup>70</sup> These are the tools of enemy situational awareness, and current doctrine fixes *dual* responsibility – hence complexity. FM 34-1 also states that “MI units are organized to support a wide range of possible missions. The doctrinal principles for C2 and the employment of MI units are similar to those used by non-MI units (for example, field artillery or engineer units).”<sup>71</sup> As we have discussed, this statement is only true to a point. MG Thomas lauds the current MI battalion and its organic analysis and control element (ACE) as an effective “receptacle”<sup>72</sup> for a tailored intelligence force package. FM 34-1 states that “the MI commander is responsible for the C2, maneuver, sustainment, and protection of his MI unit.” He is organizationally relegated, however, to the role of housekeeper for the myriad of intelligence capabilities that may be attached to the division. Per FM 34-1, as

OPLANs are activated, *the G2*... will identify MI units providing support, in and out of area of operation, and will define the command and support relationships of collectors. In short, *the G2* determines the sequence of deployment of MI personnel and equipment,<sup>73</sup> as well as their utilization. The task of task organization, therefore, has two masters, hence complexity and friction. Intelligence training is another area of dual responsibility. The G2 is “responsible for intelligence training of the unit and his staff.” The MI battalion commander is “responsible for providing the commander with a trained and mission-ready IEW force.”<sup>74</sup> Two masters – and further complexity and friction.

Finally, Stewart talks to the complexity involved in building an IEW architecture in the desert, and the flexibility (read simplicity combined with multi-disciplined intelligence and communications capability) required on the future battlefield. He also expresses the specific need, at corps and division level, to break with the CEWI paradigm of the static European defense (which drove the requirement for a signals intelligence-heavy, static MI force). He was in favor of an organization that has “a good mix of capabilities that are designed to maintain technological overmatch and to give CEWI more collection flexibility.”<sup>75</sup> In describing this desire for flexibility, a continuous trend in Stewart’s observation’s was the desire of commanders to want tangible, real or near-real time intelligence processed by there own staffs and confirmed with multiple sources.<sup>76</sup> In the words of LTG Franks, the VII Corps Commander during Desert Storm, “never hinge the success of a combat operation on sensors you don’t own.”<sup>77</sup> It is interesting to note here that the ACE was a totally unprogrammed organizational outgrowth of the desert war.<sup>78</sup> The ACE combines the former division tactical operations

center support element (the collection management, dissemination, and all-source analysis arm of the G2) with the former technical control and analysis element (the signals intelligence technical control and analysis arm under the MI battalion commander). It combined both into a single intelligence processing node that supports the division commander's targeting and information priorities. The intent is the formation of a unified, common enemy picture and the synchronization of the overall intelligence effort – and analysis/synthesis unity of effort and simplicity.

### **Future Battle**

The need for unity of command and simplicity in future intelligence operations is best understood when related to the nature of the future battlefield. TRADOC PAM 525-5, Force XXI Operations, describes that battlefield:

Future conflicts will run the gamut from general war to (operations other than war). Battle between mechanized forces will be similar to armored operations of the past three decades. However, combat involving advanced, complex, adaptive armies will take the trends of Desert Storm forward to transform the battlefield. Dominant aspects of the future conventional battlefield are battle command, extended battle space, simultaneity, spectrum supremacy, and the rules of war.<sup>79</sup>

This conceptual view takes into account the combination of improvements in weapons technology with improvements in integrative capability (to) increase weapons' lethality, range, and other physical factors..... "to impose control over people, territory, and events."<sup>80</sup> This is the essence of a Revolution in Military Affairs, as previously discussed in Chapter III. The final outcome will be organizational adaptation; this adaptation must build toward a capability that allows for successful conflict prosecution and termination

without an “all-purpose doctrinal threat template....(or) a single-prescription Army.”<sup>81</sup>

This inherently complex operating environment begs for inherently unified, simple, capable organizations that can ensure that the fog and friction associated with the future battlefield will not be exacerbated by the organization.

### **Indictment of the Current Model**

These trends, taken in the context of future conflict, lead to the evaluation that

- the current model for conducting military intelligence at division level must give way to one which establishes simplicity and unity of command through greater rapid tailorability, leader emphasis, flexibility, and task organization of capabilities to fight on the knowledge-based battlefield; and
- the current intelligence model has evolved and will continue evolving to an expanded, all-source capable, communications self-sufficient information warfare organization under a single chain of command.

## V. Considering the Options - Alternatives for the Future

“We have a rare opportunity to do something truly revolutionary in how we do the tactical intelligence business. This chance comes only a few times in the life of a branch of the Army. We need to capitalize on this opportunity and do some Army XXI style thinking.”

LTC Gary Phillips  
Commander, 104<sup>th</sup> MI Battalion  
Comments to the  
U.S. Army Intelligence Center<sup>82</sup>

The argument must now shift to the consideration of what future division intelligence organizations might look like. First and foremost, they must answer the commander's intelligence requirements and support his decisions. Per FM 100-5, the commander drives the intelligence effort. He must ask the right questions and focus the intelligence work. He must know the enemy; the commander's personal involvement and knowledge have no substitutes.<sup>83</sup> The constructs must not tear down the ability of the intelligence mechanism to provide the commander with the perspective of the thinking enemy. Was de Czege, when discussing future alternatives for MI force structure, voiced violent opposition to any idea that would reduce or eliminate the “commander's alter ego” represented by the best G2's.<sup>84</sup> It must consider the best alternatives that allow the commander to fight an information-based force, while preserving the best traditions of tactical intelligence analysis and synthesis. In the words of Peter Senge, “Managers (read commanders) must give up the old dogma of planning, organizing, and controlling. Their key task is to provide the enabling conditions.”<sup>85</sup> The following constructs, therefore, do not argue against a G2-equivalent “brain cell” with the commander to help him think through the problem; they argue for a better way of unifying effort and building in the enablers in a simple, singular construct.

Within these parameters, one potential option that the Army has considered is the elimination of divisional MI, and the consolidation of these assets at corps level. This particular alternative would merely lend to a repeat of the WWII paradigm, where intelligence was distanced from the division commander except for cases of eminent need. Potential constructs will, therefore, reflect a robust organic organization. The following constructs are two potential alternatives that fall within these parameters, and warrant consideration.

### **The Division Intelligence Command (DIVINT)**

The first of these, the Division Intelligence Command (DIVINT) will be built on the historical Division Artillery (DIVARTY) evolutionary example of building centralized command and control mechanisms to optimize the use of emerging technological capabilities. The historical emergence of this force-multiplying organization in light of critical developments in technology provides an excellent parallel to the idea of command advocacy for emerging information capabilities, especially in light of the concept of information as combat power. The defining characteristics of this construct are

- Centralized command and control under a colonel intelligence (information) warfighter.
- A decidedly larger division-level force structure to allow for a direct support battalion for each maneuver brigade, to include an ACE.
- A robust general support battalion including organic, multi-disciplined intelligence collection and integration means, and an Intelligence and Electronic Warfare

Coordination Center (INTCOORD).

The origins of the DIVARTY can be directly traced to the “increased ranges and firepower (of artillery) as demonstrated in the Franco-Prussian war. (This) encouraged artillery officers to develop an effective method of indirect fire to protect their guns in defilade positions and take advantage of the long ranges to hit targets beyond the limits of human eyesight.”<sup>86</sup> The Russian officer Karl G. Guk catalyzed indirect fire methodology by describing what are recognized as the modern methods of using the compass, aiming point, and forward observer.<sup>87</sup> Indeed, indirect fire was theoretically becoming conventional wisdom, yet American tactics and training were slow to move from the age of smoothbore artillery, even after the accession of the M1885 3.2 inch gun.<sup>88</sup> The Spanish-American War indicated that although indirect fire technology and methods theoretically changed the size of the battlefield, tactics had not kept the pace. Only able to employ direct fire, American artillerymen preached moving their field pieces as close as possible to enemy infantry even if such action brought them within range of enemy small arms.<sup>89</sup> The perspective of the line infantry significantly impacted on this attitude. In *Report of the Santiago Campaign* (1907) LTC Arthur L. Wagner wrote, “There was much dissatisfaction felt by the infantry because of the position of Dillenback’s artillery in the engagements of the 10<sup>th</sup> and 11<sup>th</sup> of July.” From the field artillery’s perspective, Wagner comprehended why the guns were placed 600 to 800 yards behind the infantry. Yet, the average infantry soldier understood little about the science of gunnery and wanted the guns on line with them for moral support.<sup>90</sup>

Technology would finally dictate the practicality of officially adopting indirect

fires. The 1901 board of Ordnance and Fortifications/Ordnance Department adoption of the M1902 howitzer (hydrospring recoil, panoramic sights, fixed ammo of shrapnel and HE steel-shell, smokeless powder, and 6000 yard range) moved the War Department to prepare an entirely new field artillery drill regulation and adopt indirect fire.<sup>91</sup> Given enhanced communications means (wire, radio, etc.) the next logical steps were in the realm of control.

The first distinct change in fire control was the role of the forward observer. The traditional role of the forward observer – spotting enemy movements – gave way to directing observed fires. The observer's new duties simultaneously changed battery operations. During the age of direct fire, each gunner fired his piece independently. With the advent of indirect fire, the forward observer aimed the gun. As a result, the battery became a firing unit and not just a tactical element, and the battery commander assumed a more instrumental role in controlling fire than he had done in the past. Converting from signal flags and runners to field telephone allowed the full impact of indirect fire and the forward observer to be felt.<sup>92</sup>

This more scientific atmosphere would have a spiraling effect on organization, training, and doctrine for decades to come. “Although the reforms in guns, materiel, tactics, and organization during the years since 1898 had revolutionized the field artillery, solving the communication problem and developing field artillerymen were imperative before indirect fire could be truly exploited.”<sup>93</sup> Also, the primary debate concerning organization revolved around how to build the artillery to achieve massed effects while supporting troops in contact. Herein lies a significant parallel to the development of the

DIVINT construct. For the field artillery, this problem would not be resolved entirely until preparations for WWII were underway.

The triangular division model tested in the Louisiana Maneuvers and approved in 1939 would be the birth of what we currently recognize as the DIVARTY.<sup>94</sup> The progress in wireless communication would also re-open the discussion on appropriate means of controlling fires,<sup>95</sup> and specifically opened for consideration developing methodologies to rapidly centralize firing data computations at the battalion to make it a firing unit.<sup>96</sup> The Army adopted the fire direction center (FDC) in 1941 as a means of centralizing and computing firing data at the battalion. “As a result, the field artillery acquired the capability of delivering massed fires rapidly and shifting fire around the battlefield at will.”<sup>97</sup> These capabilities would pay dividends beginning with the campaign in North Africa, and throughout the war. A captured Nazi officer observed that American artillery was the most deadly that he had experienced. Per General Omar Bradley, “the American field artillery technique of massed fires was a major contributing factor toward the early and successful conclusion of the operation” in Africa.<sup>98</sup>

Korea would serve to validate massing of fires. Commanders from the outset used artillery to offset superior numbers.<sup>99</sup> Control techniques would once again mature, however, to expand the commander’s tool kit of massed fires. Army commanders coupled this awesome artillery firepower with unprecedented air and naval support. Because of the development of the fire support coordination center (FSCOORD) after WWII to synchronize tactical air, naval gunfire, and artillery support, an artillery commander could deliver any kind of fire and devastate targets of opportunity. The

center allowed an air strike to take place without interfering with artillery fire and gave the forward observer the added responsibility of being the eyes of the field artillery and advising the fire support coordinator on where, when, and what type of fire should be used.<sup>100</sup>

Artillery would culminate its evolution in the wake of the 1973 Arab-Israeli war, which motivated the field artillery to reorganize the forward observer team to take advantage of technology that would appear in the 1980's. Fire Support Teams (FIST) would work at the maneuver company level to "ensure that fire support experts would train with the maneuver unit, provide experienced fire support personnel at all times, increase the flexibility of the field artillery battalion, and coordinate tactical air strikes." Approved by the army for implementation in 1977, the field artillery branch also recommended FIST presence in air cavalry and attack aviation units, and integration of technologies. It would direct activities of all the company's observers, optimize fire support by integrating all fire support assets into a coherent team, and help compensate for inferior numbers.<sup>101</sup>

The DIVINT construct (see Appendix 13) is a close parallel to the historical evolution of the DIVARTY. The common denominator in both of these is the need to organizationally leverage technologies to mass and control effects. The DIVARTY evolved in order to mass and control the effects of firepower, given the advent of indirect fire technologies, long-range breech loading artillery, and reliable wireless communications. The DIVINT construct is an evolutionary template (based on the DIVARTY precedence) for the massing and control of information, and more

specifically, knowledge of the enemy.<sup>102</sup> A view of the DIVINT construct from the ground up will bring these parallels into greater focus.

The DIVINT is built on the premise of a flattened structure army-wide<sup>103</sup> that places a far more robust intelligence capability directly in the hands of the division commander. The Direct Support (DS) battalions are designed to provide full spectrum intelligence support to each maneuver brigade and the deep operations control center (DOCC). All intelligence collection and processing soldiers (specifically scouts and S2 sections) would be consolidated in this unit to form intelligence support teams similar to the fire support officers (FSO) and FISTS currently used by DIVARTY. An ACE (containing the same communications, analytical and databasing capability currently residing at division) would support the brigade commander.<sup>104</sup> Analysis and control teams would support maneuver battalion commanders. Intelligence support teams would work in support of company commanders, and in concert with the FIST to provide an integrated, focused recon-strike team. Air scouts and tactical unmanned aerial vehicles (UAV's) would provide a robust organic collection capability that could directly extend brigade and battalion commanders' real-time situational awareness to the full extent of direct support artillery, thus enabling a true brigade deep attack capability. Three key assumptions drive the DS battalion construct:

- The need for a trained, robust intelligence analysis and synthesis capability down to the lowest level, as a means for massing the combined effects of knowledge, fire, and maneuver.
- The need for *information warriors* - specialists in analysis, synthesis, and database

operations<sup>105</sup> - in support of commanders at the lowest level to work in a unit environment that allows them to build toward intelligence readiness through continuous engagement with potential or actual adversaries, throughout the spectrum of peacetime and conflict.

- The need to integrate observation efforts with the fire support community. The tempo of battle and the slowness of data input means reduces the ability of maneuver units to concentrate on both the information fight and the physical fight.

These assumptions also apply to the next battalion construct.

The general support (GS) battalion would contain the intelligence coordination center (INTCOORD), a parallel development to the FSCoord. Built around the current ACE, the INTCOORD would serve as the division commander's "alter ego," integrating and synchronizing organic and attached IEW capabilities with fires and maneuver to maintain continuous, full-spectrum capabilities overmatch. From a collection standpoint, the GS battalion would contain a more robust, multi-discipline intelligence collection and processing capability, especially in the imagery and human intelligence disciplines. Imagery intelligence enhancements would allow for the full exploitation of imagery products from national and theater level assets. Human intelligence enhancements would be in the form of organic source operations teams and strategic debriefing teams – both of whom have been in heavy demand in recent force projection operations. Organic, ground-based signals intelligence would remain at division level, since this would be the lowest level of operation where a viable baseline of sensors could be established. The ground-based signals intelligence operation would be fully integrated with a robust flight

operations company including both GUARDRAIL and QUICKFIX, providing a joint-force ready package of integrated sensors. Finally, multi-disciplined counter-intelligence operations (MDCI),<sup>106</sup> in conjunction with deception, civil affairs, and psychological operations, would become “big business” (in the Patton/Koch vernacular) as a means of taking the information battle to the enemy.

Of final note is the disposition of the cavalry squadron under this construct. The cavalry (like other maneuver units) would be subject to intelligence tasking through the G3 from the INTCOORD. The high profile of long-range, organic sensors at every echelon, however, would allow the division commander to weight the employment of his cavalry squadron in favor of deep strike and exploitation, thus facilitating shock and moral dislocation of the enemy.

### **The Chief of Reconnaissance Troops (CRT)**

The second organizational construct is the former Soviet model for the Chief of Reconnaissance Troops (CRT), and the Reconnaissance, Surveillance, and Target Acquisition (RSTA) Tactical Operations Center (TOC). FM 100-2-series Soviet threat manuals and historical accounts of Soviet tactical intelligence provide a conceptual template for the CRT as a command and control mechanism for tactical intelligence operations. The defining characteristics of this construct are

- The incorporation of a dual-allegiance relationship, and
- The CRT’s command of all division-level reconnaissance assets (to include the division cavalry squadron and any long-range surveillance capability).

The former Soviet Army concept for intelligence was possibly ahead of its time.

Their model was built on the presumption of tactical operations tied together into operational campaigns to achieve strategic objectives – *operational art*. Also, David Glantz, in his study of Soviet attitudes toward intelligence, notes, “As is so often the case, the Soviets use a single generic term, *razvedka*, to describe all actions necessary to achieve a better understanding of the enemy. The term *razvedka* means both intelligence and reconnaissance and, with an appropriate adjectival qualifier, it pertains to every possible means of intelligence collection and analysis.”<sup>107</sup> Concepts of dual allegiance and chief of branch, according to our old FM 100-2-1, Soviet Army Operations and Tactics, supported this concept of operational art:

Each branch of service, except for tank and motorized rifle, is represented on the division staff by a chief of the branch. Collectively, these officers are referred to as the chiefs of arms and services. They are responsible to the division commander but receive additional instructions and guidance from their counterparts at the next higher level.... While the possibility for confusion exists, the Soviets do not view this as an infringement on command prerogative. On the contrary, it ensures unity of command at the highest levels. The fire plan, for example, is viewed as an aid to planning, and not a constraint. The division commander (through the Chief of Rocket Troops and Artillery) learns from the army fire plan which targets will be attacked by non-divisional artillery. He can then decide which targets to attack with division artillery.... If the system works, the administrative and technical burden on the division commander is reduced, and he can concern himself with the tactical conduct of his maneuver units... The drawback is the increased need for (external) coordination.<sup>108</sup>

Given this concept of dual allegiance, Soviet doctrine, then, articulated the following duties for the “senior intelligence officer:”

The second section, or intelligence section, is headed by the chief of intelligence, who is also chief of reconnaissance troops. He is part of an intelligence chain of command which originates at front. In this regard, division-level intelligence efforts fit into an overall intelligence plan.... During combat, the division intelligence officer directs the efforts of subordinate intelligence sections and reconnaissance units....

(ensuring) aggressiveness, continuity, timeliness, reliability, and accuracy (the principles of Soviet reconnaissance).<sup>109</sup>

There is a final point of emphasis regarding the Soviet intelligence model.

According to Glantz, “Razvedka is the *first* mechanism in a carefully orchestrated command and control cycle.”<sup>110</sup> The final issue of the capstone Soviet doctrinal manual

Taktika confirms this emphasis:

“Tactical reconnaissance (razvedka) is the most important form of combat support. It is the sum total of measures implemented with the goals of acquiring, collecting, and studying information on the enemy, on the terrain and on the region of forthcoming operations in behalf of preparation for and successful conduct of battle.”<sup>111</sup>

The CRT construct (see Appendix 14), like its Soviet predecessor, would place all existing organic reconnaissance means under the CRT at both division and brigade level. The construct requires a somewhat modified division force structure. Razvedka would be the guiding principle – an emphasis on leveraging the entire division as an intelligence collection and processing mechanism. The dual allegiance role of the CRT would integrate this mechanism with that of units at echelons above division, to include the joint force commander. The intent is intelligence unity and coverage from the tactical to the strategic level as a matter of regular doctrine and practice. A view of the CRT construct from the top-down will show how it endeavors to put razvedka into practice.

The division CRT would exercise command over the MI battalion and the cavalry squadron, while exercising operational control over the flight operations company and the brigade CRT's. The division CRT would control the division intelligence battle at a RSTA TOC. This *razvedka* command and control cell would be built around the existing ACE as an intelligence warfighting cell, guiding integration, collection and processing at

all levels to gain the most comprehensive, near-real time view of the battlefield. Each brigade CRT would attach a liaison officer (LNO) to the RSTA TOC equipped with an all-source analysis system (ASAS) remote workstation. The LNO's would ensure the continuous bottom-up and top-down flow of intelligence and intelligence-related taskings and requests that would

- Keep the supported commander fully apprised of the intelligence coverage and picture provided by higher, lower, and adjacent units, and
- Identify gaps in the supported commander's knowledge and where he must focus his assets.

The RSTA TOC concept has proven its viability in Advanced Warfighting Experiment (AWE) Prairie Warrior 96, and at the National Training Center. In both of these cases, the RSTA TOC, under the control of a CRT-equivalent commander, provided continuity of coverage while cross-cueing and dynamically re-tasking sensors. The RSTA TOC proved particularly beneficial in these examples in the integration of intelligence for deep operations, and in integrating national-level and special operations capabilities.<sup>112</sup> The proposed construct would institutionalize this performance, and provide an intelligence command and control node from which the CRT could satellite. His primary function will be to act as the commander's "alter ego" while simultaneously bringing the eyes of the division to bear at the decisive point in the battle. The RSTA TOC empowers this combination of "brain cell" and "MI gunner."

The MI Battalion under the CRT would be largely the same as the GS battalion under the DIVINT construct, minus the INTCOORD. The force structure requirement

for multi-disciplined flexibility (in the form of enhanced imagery and human intelligence, flight operations, and multi-discipline counter intelligence) exists in both constructs. The cavalry squadron is subordinate to the division CRT in this model to allow for the continuous ground combat reconnaissance so heavily emphasized in the former Soviet model. This would also be necessary since the organic sensor profile of the division is not as expanded in this construct as in the DIVINT. Hence, unlike the DIVINT, the reconnaissance and surveillance role of the cavalry is preeminent in the CRT construct. The brigade CRT's would likewise command their organic MI company (direct support company currently assigned to the MI battalion on the A-Series TOE) and a cavalry troop (from scout and ground troop slots in the maneuver battalions – see F-series TOE). A parallel system of operational control and LNO's would extend to battalion level.

## **VI. Evaluation of Alternatives**

...in most modern armies, the diversity of operating environments, equipment sophistication, increased tempo, and substitution of physical knowledge for traditional physical control will place unprecedented demands on soldiers and leaders. To win on future battlefields, future leaders of all armies must be skilled in the art of military operations, capable of adjusting to the temporal and spatial variations of new battlefields.

TRADOC Pamphlet 525-5,  
Force XXI Operations,  
concerning future battle

The DIVINT and CRT constructs are both viable, acceptable start points for an MI construct that will allow commanders to gain and maintain a knowledge advantage over future adversaries. The application of the features of force projection intelligence will now provide a means for assessing the most suitable of these two alternatives. Each feature will provide a singular criterion for analyzing the relative suitability of each alternative. This analysis will then provide the backdrop for the synthesis of an overall evaluation.

### **Always Engaged**

The DIVINT construct provides a decidedly more suitable capability for the division commander to stay engaged with potential adversaries. The construct's emphasis on providing an in-place collection and processing infrastructure down to the lowest levels provides the commander with the ability to assess multiple contingencies, and provide early prioritization and focused preparation for those contingencies. These capabilities are key to the form of intelligence readiness required in force projection. Also, the permanent presence of the INTCOORD with other special coordinating staffs provides for a more economically managed intelligence mechanism that is focused on the

right things to the right level of detail to facilitate the build from deliberate planning to crises action planning to execution. The CRT construct provides a solid early prioritization and preparation capability, but lacks the processing depth to provide continuous intelligence “engagement” on multiple contingencies throughout the range of military operations. The commander must rely on a higher CRT or for national or theater-level intelligence agencies to fully develop multiple contingencies. These external players may or may not provide a product that is focused on the needs on the division commander. The DIVINT construct allows for the division commander to have a robust strategic intelligence clearinghouse that is focused on his needs - all the time.

#### **Downwardly Focused**

The DIVINT construct provides a somewhat more suitable capability to downwardly focus intelligence to the supported commanders at and below division level. Both the DIVINT and CRT can provide a usable, timely intelligence product. The DIVINT’s proliferation of the intelligence support officers (ISO) and intelligence support teams (IST) down to company level, however, allows for a more focused push of intelligence products tailored to the needs of the supported commander at the lowest level possible.

#### **Simultaneously Supported**

The CRT construct provides a somewhat more suitable capability to simultaneously support multiple echelons. The design of the CRT, with its “dual allegiance” command and control methodology, and razvedka as the unifying principle at all levels, is built with simultaneous support of multiple echelons in mind. The CRT

facilitates and actually pursues as its critical objective a simultaneously shared, common picture of the enemy. Razvedka would guide the build of this shared picture from all available collection assets and analysis/synthesis nodes - national, theater, and Army level. The commander's organic assets, while consistently focused on his priority intelligence requirements, would simultaneously provide data to higher, lower, and adjacent units. The DIVINT construct, while providing the commander with a robust, nearly autonomous intelligence arm, tends to focus primarily on the needs of the supported commander as opposed to a simultaneous view.

### **Coverage Enhanced**

The DIVINT and CRT constructs are equally suitable for providing coverage enhanced capabilities to leverage technology for the purpose of seeing the entire width and depth of the battlefield. The DIVINT construct allows for a slightly better capability to tailor complimenting and combined intelligence sources from organic capabilities. The CRT allows for a slightly better capability to leverage national and theater capabilities early, given the operational imperatives of razvedka. On the whole, however, both constructs allow for the optimization of available technologies and systems to provide the highest resolution, most near-real time intelligence.

### **Skip Echelon Flexibility**

The DIVINT construct provides a slightly more suitable capability to provide skip echelon support. This particular criterion, and the terms used to describe it, is related to simultaneous support. Skip-echelon flexibility, however, seeks to allow for the push and pull of critical intelligence across echelon to where the need is most great, while the

emphasis of simultaneous support is a common picture, hence common situational awareness and perspective of the battlefield. The DIVINT has a slight advantage in that it provides multiple paths (through higher, lower, and adjacent support teams and support officers) to potential intelligence customers. It also provides for a more robust analysis and synthesis capability at each echelon to facilitate the assimilation of these products.

### **Organizations Redesigned and Disciplined Operations**

The DIVINT and CRT constructs are equally suitable for providing redesign and disciplined operations capabilities.

### **Synthesis and Overall Evaluation**

Each of the features of force projection intelligence is given equal weight in the overall evaluation of the alternative intelligence models. Given this equal weight, and the preceding analysis, the DIVINT is the most suitable construct for an alternative to the current division-level military intelligence model. The DIVINT provides particularly strong capabilities in the following areas:

- It allows the commander to continuously engage potential adversaries through the use of his intelligence arm.
- It provides the means for an intelligence-ready force that can collect and process intelligence on a broader range and greater number of potential adversaries.
- It allows for a higher degree of combined arms integration to the lowest levels.

It facilitates the downward focus of usable, timely, tailored intelligence where it is needed the most, and specifically provides skip-echelon flexibility to allow for the push and pull of critical, perishable intelligence.

## VII. Conclusion

Many solutions to the dilemma of uncertainty for the commander are technical. But there can be no information revolution without the human influence and understanding of soldiers and commanders who link and integrate information, technology, and action.

FM 100-6, Information Operations<sup>113</sup>

The intent of the Army's force development efforts is to build a better bayonet in the form of organizations that optimize materials in the hands qualified soldiers and leaders. The information-based battlefield is a complex environment, requiring the development of an organizational "bayonet" that allows for the use of all forms of combat power, used in the right combinations, to gain decisive victory. This monograph has attempted, given the advent of information as combat power, to apply J.F.C. Fuller's dictum to "show what might happen, not what will happen, (even though) the suggestions....may prove so costly as to be unpractical."<sup>114</sup>

The monograph paints a vignette in light of information as combat power, and relevant information and intelligence (RII) as a crucial component of the information element of combat power. It also takes into account the historical, sociological, and conceptual trends pointing toward the continuing growth of the "information society," and a parallel information-based force. Given these trends, the current divisional MI model is not an effective means of providing RII to the information based force. The Division Intelligence Command (DIVINT) provides the best alternative to the current divisional MI model. It provides the best combination of the features of force projection, information-based intelligence in a single, unified, simple construct. It assumes the availability of force structure to form the DIVINT based on resource priority given to that

combination of the elements of combat power, to include information-based arms, that will best serve the force.

The following are other ancillary recommendations that may facilitate the further study of information-based force development.

- With emerging technologies specifically in mind, the Army needs to seriously study the manning implications of incorporating new technologies, especially in terms of attaining that level of information-force readiness. Our sister services have a greater depth of experience in incorporating information systems into their force structures. Also, as noted earlier, the National Security Agency is most likely our nation's first information-based defense institution.
- We must build a vision around information as combat power and adjust the total force accordingly, regardless of the impact on the standing balance of power among the combat arms "guilds."
- We must consider similar constructs for the signal community. The MI community cannot do both signal and intelligence - no matter how hard we try. We may know the concepts (we have to - MI does not want to be relegated to the role of historian by bad communications), but making it happen is a different matter. Communications warfighters with the networking and full spectrum utilization know-how must be enabled to do their jobs in an information-based force.
- We must re-define readiness (in terms of what is contained on unit status reports and similar vehicles) based on the viability of databases and the viability of the communications architectures that allow the force to "surge" information to gain an

assymmetric advantage in a given contingency.

- We must read our doctrine and future concepts. We must be a learning organization, whether we want to acknowledge it or not. This is a natural, potentially serendipitous by-product of our “information society.” The individuals on the team, however, must readily assume the responsibility to understand our doctrine and concepts - to intellectually “equip” themselves. They must then have the moral determination and good common sense to use these ideas as points of departure and deviation, not inflexible, prescriptive stumbling blocks. To do otherwise is a reflection of arrogance, laziness, or intellectual timidity. As Fuller states:

Accept nothing as fixed. Realize that the circumstances of war are ever-changing, and that, consequently, organization, administration, strategy, and tactics must change also; and if during peace time we cannot change them in fact, we can nevertheless change them in theory, and so be mentally prepared when circumstances require that changes should be made.<sup>115</sup>

The alternatives in this paper are only two possibilities for the intelligence paradigm; more should be considered that allow the maturation of a unified, simplified, force projection, information-based intelligence capability that doctrine, concepts, and technological trends tend to warrant. We must be mindful of the fact that a higher and higher proportion of our society is becoming information systems literate. We would do well to harness this power, and build our organizations so as to maximize the capabilities of the American warfighter, not hamstring him.

## ENDNOTES

- <sup>1</sup> Force XXI... America's Army of the XXIst Century (Ft Monroe: Office of the Chief of Staff, U.S. Army, Director of Louisiana Maneuvers, 1995), p. 13.
- <sup>2</sup> *Ibid.*, p. 7.
- <sup>3</sup> FM 100-6, Information Operations (Washington, DC: Department of the Army, 1996), p. 2-6.
- <sup>4</sup> TRADOC Pamphlet 525-5, Force XXI Operations (Ft. Monroe, VA: U.S. Army TRADOC, 1 August 1994), p. 4-5.
- <sup>5</sup> FM 34-1, Intelligence and Electronic Warfare Operations (Washington, DC: Department of the Army, 1994), p. 1-12 to 1-13.
- <sup>6</sup> *Ibid.*, p. 2-7.
- <sup>7</sup> John F. Stewart, JR., BG, Operation Desert Storm: The Military Intelligence Story: A View from the G-2 (U.S. Army, Riyadh, Saudi Arabia: 3D U.S. Army, 27 April 1991), p. i.
- <sup>8</sup> Kent R. Greenfield, Robert R. Palmer, Bell I. Wiley, The Organization of Ground Combat Troops. (Washington, DC: Historical Division of the United States Army, 1947), p. 273.
- <sup>9</sup> Stephen C. Conrad, "The History of Military Intelligence." (Individual Study Project. Carlisle Barracks, PA: U.S. Army War College, 1989), p. 6.
- <sup>10</sup> *Ibid.*, p. 6.
- <sup>11</sup> Omar N. Bradley, A Soldier's Story of the Allied Campaign from Tunis to the Elbe (New York, NY: Henry Holt and Company, 1951), p. 33.
- <sup>12</sup> Conrad, "The History of Military Intelligence," p. 7.
- <sup>13</sup> *Ibid.*, p. 8.
- <sup>14</sup> *Ibid.*, p. 9.
- <sup>15</sup> *Ibid.*, p. 9.
- <sup>16</sup> Matthew B. Ridgway, The Korean War (Garden City, NY: Doubleday, 1967), p. 13-14.
- <sup>17</sup> Conrad, "The History of Military Intelligence," p. 12.
- <sup>18</sup> Joseph Muckelroy, Telephone Interview (Force Modernization, Combat Developments, U.S. Army Intelligence Center and FT. Huachuca, 30 Sep 97).
- <sup>19</sup> Sidney T. Weinstein, Evolution of Military Intelligence 1944-1984 (Ft. Huachuca, AZ: U.S. Army Intelligence Center and School, 3 Jan 1984), p. 3.
- <sup>20</sup> *Ibid.*, p. 8.
- <sup>21</sup> *Ibid.*, p. 16-18.
- <sup>22</sup> *Ibid.*, p. 23-24.
- <sup>23</sup> Greenfield, Palmer, and Wiley, The Organization of Ground Combat Troops, p. 272.
- <sup>24</sup> Stewart, Operation Desert Storm, p. I.
- <sup>25</sup> *Ibid.*, p. 38.
- <sup>26</sup> *Ibid.*, p. I.
- <sup>27</sup> *Ibid.*, p. 3.
- <sup>28</sup> Was de Czege, Huba. Telephone Interview (26 Sep 97).
- <sup>29</sup> FM 34-1, p. v.
- <sup>30</sup> Army Vision 2010 (Washington, DC: Department of the Army, 1996), p. 10.
- <sup>31</sup> FM 100-6, p. v.
- <sup>32</sup> B.H. Liddel-Hart, "Armament and its Future Use," The Yale Review 19 (1930), p. 652.
- <sup>33</sup> Gary E. Phillips, "Intelligence to the Point of the Spear," Military Intelligence 21 no. 2 (Apr-Jun 95), p. 43.
- <sup>34</sup> BG(P) John F. Stewart, JR., Speech (Commander, US Army Intelligence Center and Ft Huachuca. Presented to the intelligence officers of the 82d Airborne Division as part of ASAS new equipment training, 10 Oct 97).
- <sup>35</sup> Martin Van Creveld, Command in War (Cambridge, MS: Harvard University Press, 1985), p. 264.
- <sup>36</sup> James R. Beniger, The Control Revolution: Technological and Economic Origins of the Information Society (Cambridge, MS: Harvard University Press, 1986), p. 6-16.
- <sup>37</sup> Alvin and Heidi Toffler, War and Anti-War: Survival at the Dawn of the 21st Century (New York, NY: Little and Brown Company, 1993), p. 41; Toffler refers to WWII in a section of chapter 6 entitled "Death on

the Assembly Line,” and describes the awesome potential for industrialized death realized in WWII. He specifically cites Jews murdered “factory-style,” and the mass bombings of Japan and Germany. He refers to the Ludendorf model of total war waged with the entire society converted into a “war machine,” in Toffler’s words, it (WWII) “was industrial-style rationalization carried to its ultimate.”

<sup>38</sup> *Ibid.*, p. 69; By Toffler’s standard, “knowledge...was becoming key to the production of economic value.” The extension in logic is “knowledge at the center of warfare as well.” Knowledge-based warfare, then, in the larger context of operational art began to take form during WWII with the incorporation of integrated, knowledge-based warfare means over a large, distributed battlefield (or theater) over a period of time: omnipresent wireless communications, Blitzkrieg, the use of strategic intercepts, the crude attempts at precision bombing, and the first true institutionalized, integrated application of modern communications, intelligence, and electronic warfare means. This was arguably the first war where Beniger’s control revolution was manifested in military conflict.

<sup>39</sup> Carl H. Builder, The Masks of War: American Military Styles in Strategy and Analysis (Baltimore, MD: Johns Hopkins University Press, 1989), p. 192.

<sup>40</sup> Beniger, The Control Revolution, p. 9-10.

<sup>41</sup> TRADOC Pamphlet 525-5, p. 3-2 to 3-3; 525-5 goes on to state “Soldiers and information - the centerpieces of future operations - are critical in that they permit changes in the dimensions of the battlespace through different combinations of maneuver, fires, and information operations. By mastering information, we can potentially command operations at an operational tempo no potential enemy can match.”

<sup>42</sup> FM 100-6, p. 2-2.

<sup>43</sup> *Ibid.*, p. 3-0.

<sup>44</sup> Builder, The Masks of War, p. 33.

<sup>45</sup> COL Keith Alexander, Telephone Interview (J2-P, Joint Chiefs of Staff, 3 Nov 1997); Alexander notes that as a combat developer for MG Weinstein, then the commander of the Army’s Intelligence Center, he developed a six-hour, 2000-slide briefing entitled The MI Story. Weinstein aimed this presentation initially at GEN Cavazos, the FORSCOM Commander. According to Alexander, Cavazos was openly against any tactical MI force structure initiatives, and was openly skeptical of the worth of MI as a battlefield operating system. Weinstein used the MI story as a comprehensive vignette of intelligence performing as a “system of systems.” As such, it was one of the first lay-downs of integrated, multi-disciplined intelligence designed to provide the tactical commander with an all-source view of the enemy. At the center of the presentation, CEWI provided the organizational glue to provide this system of systems as an organic capability, responsive to the commander’s personal intelligence requirements, while reducing the redundancy and compartmentalization in the hybrid CBTI/ASA structure. Weinstein subsequently briefed GEN Thurmon, the vice chief of staff to GEN Vuono, and the senior systems integrator for the Army. According to Alexander, the briefing served its purpose in educating the Army’s senior leaders, but the general attitude toward MI as a viable battlefield operating system would not change until the Combat Training Centers would validate the importance of tactical intelligence to the success of tactical operations.

<sup>46</sup> Was de Czege interview.

<sup>47</sup> Wilma Bernardo, Telephone Interview (Force Modernization, Combat Developments, U.S. Army Intelligence Center and FT. Huachuca, 6 Nov 97), and Ben Stutler, Personal Interview (Requirements Documentation Directorate, US Army Combined Arms Center, 27 Oct 97); Per Bernardo and Stutler, two themes were universally applied when reviewing force structure during the Army’s last functional area analysis (FAA): a) the Army will not get larger; b) leverage technology to do more with less. The current trend, however, when applying the second theme is to apply it to individual-level performance as opposed to taking a holistic, systemic view as Beniger’s “information society” would dictate.

<sup>48</sup> Bernardo interview, and Ben Stutler, Slides representing the current A-Series and Force XXI TOEs (Requirements Documentation Directorate, US Army Combined Arms Center, 20 June 1997); the slides at Appendices 8 and 12 show a steady state for MI organization in the current A-Series and FXXI TOE’s. What is not readily apparent is the loss the division’s battlefield deception (BAT-D) cell. According to Bernardo, this was a trade-off (“accepted risk”) to allow for continuing modernization, and to compensate for the “real world manning ceilings” that affect the Army as a whole.

<sup>49</sup> TRADOC Pamphlet 525-5, p. 4-5.

<sup>50</sup> Beniger, The Control Revolution, p. 23; Beniger succinctly diagrams the geometric growth of information-based vocations in the US (from 0.2% in 1800 to nearly 50% in 1980) and uses these compelling numbers to begin the description of his information society. The current method for marrying soldiers to tactical systems in the “above the line” force is in AR 71-32, which prescribes a universal 2 to 1 ratio of soldier to position (theoretically allowing one twelve-hour shift per soldier). The National Security Agency (NSA - the DoD’s most venerable knowledge-based organization) standard for resourcing, according to USSID 110 (Collection Management) is a 5 to 1 ratio (3x8 hour shifts, 1 off duty, 1 school/sick/TDY/in transit). The personal experience of this author as a commander of a voice intercept company under NSA control validates this ergonomic requirement. A knowledge-based (“always engaged”) environment demands this ratio, given the level of cognitive detail and mental exertion required to acquire, build, and focus information as combat power. This would tend to warrant study of the baseline standards for manning information-based, crew-served weapons systems (such as ASAS and the other ATCCS family of systems) contained in AR 73-32 to reflect the reality of Beniger’s “information society” and the institutionalized wisdom of NSA.

<sup>51</sup> FM 34-1, p. 1-12 to 1-13.

<sup>52</sup> TRADOC Pamphlet 525-5, p. 4-5.

<sup>53</sup> FM 100-5, Operations (Washington, DC: Department of the Army, 1993), p. 2-6 to 2-7.

<sup>54</sup> Thomas A. Keaney, and Elliot A. Cohen, Gulf War Air Power Survey Summary Report (Washington DC: US Government Printing Office, 1993), p. 238; According to Keaney and Cohen, four conditions are required for an RMA to occur:

- 1) development/maturation of new technologies
- 2) integration of new technologies into new military systems
- 3) operational concepts for the new technologies/systems developed and implemented
- 4) organizational adaptation

They go on to state, “Technology alone does not a revolution make; how military organizations adapt and shape new technology, military systems, and operational concepts matter much more.” Author’s note – this equals organization for combat to reduce fog and friction, and to optimize systems in the hands of soldiers and leaders.

<sup>55</sup> Carl von Clausewitz, On War (Princeton, NJ: Princeton University Press, 1984), p. 119-20; Clausewitz refers to friction as “the force that makes the apparently easy so difficult.” In its essence, he describes it as the product of many moving parts working with and against each other: “...we should bear in mind that none (of the military machine’s) components is of one piece; each part is composed of individuals, every one of whom retains his potential or friction.” He admonishes leaders to “know friction in order to overcome it whenever possible, and in order not to expect a standard of achievement in his own operations which this very friction makes impossible.”

<sup>56</sup> FM 34-1, p. iii; This version of FM 34-1, like other proponent capstone manuals, derives its tone from the 1993 version of FM 100-5, which is built on the premise that “the Army’s doctrine is firmly rooted in the realities of current capabilities. At the same time, it reaches out with a measure of confidence to the future. Doctrine captures the lessons of past wars, reflects the nature of war and conflict in its own time, and *anticipates the intellectual and technological developments that will bring victory now and in the future.*” (FM 100-5, p. v) Hence, it provides “a basis for IEW doctrine, training, and combat developments, (helping) us contain and control the simultaneous and contradictory requirements for continuity of purpose, growth, and change.” (FM 34-1, p. iii)

<sup>57</sup> *Ibid.*, p. vi; In force projection operations, getting to the battlefield and winning decisively while protecting American lives requires that the intelligence effort begin long before that first day (“day one of any battle”). Also, in the force projection era the nature of mission-based intelligence requires commanders to redefine intelligence *readiness*: MI must develop broad knowledge on priority areas, update these databases daily, surge for emerging missions, and inform commanders and MI leaders to allow for daily direction. To maintain this readiness, MI must provide routine, direct, habitual links allowing for focused intelligence throughout the spectrum of peace and conflict. (author’s note - this prescriptive capability is at the heart of the Intelligence Corps motto - *Toujours En Avant* - Always Out Front.) See fig 1-1 of FM 34-1, p. 1-2 for a graphic description of the force projection paradigm for MI. This paradigm, as opposed to the Cold War methodology, requires a relatively broad band of integrators who can define a broad baseline of threats and

plug-in all available appropriate collection and processing capabilities - mud to God - into the analytical/synthetic receptacle (usually the Analysis and Control Element) at their level - to build knowledge quickly and support the commander's decisions.

<sup>58</sup> Ibid., p. 1-11 to 1-13.

<sup>59</sup> Ibid., p. 2-7 to 2-15.

<sup>60</sup> Liddel-Hart, "Armament and its Future Use," p. 653, 659.

<sup>61</sup> Weinstein, Evolution of Military Intelligence 1944-1984, p. 9; the original TARS-75 battalion organizational concept recommended a DS company that would contain the BICCs for all maneuver brigades and battalions, DIVARTY and associated DS battalions, and the cavalry squadron. The purpose of the BICC was "for analysis and dissemination of intelligence at division, brigade and battalion." The intent was to "create a chain of trained intelligence professionals to assist S2/G2 sections in collecting, analyzing, and disseminating intelligence."

<sup>62</sup> Stewart, Operation Desert Storm, p. 36; Stewart states "It is clear that having an MI unit with commander and staff working in support of G2 is a doctrinal tenet that MI must hold. The G2, in his role as senior intelligence officer for the commander, must have the freedom to direct, manage, produce, analyze, program, and staff. It is the MI unit commander who trains, task organizes, and implements."

<sup>63</sup> Van Creveld, Command in War, p. 269; Van Creveld provides us with this mandate when viewing redundant organizational structures: "The nature of the task to be performed is not the only determinant of the amount of information required for its performance; equally important is the structure of the organization itself. The more numerous and differentiated the departments into which an organization is divided, the larger the number of command echelons superimposed on each other, the higher the decision thresholds, and the more specialized its individual members, then the greater the amount of information processing that has to go on inside the organization."

<sup>64</sup> Ralph Van Deman, The Final Memoranda: Major General Ralph H. Van Deman (Wilmington, DE: SR Books, 1950), p. xvi.

<sup>65</sup> DoD S-5105.21-M-1, Sensitive Compartmented Information Administrative Security Manual (Washington, DC: Department of Defense, Mar 95); and Army Regulation 380-28, Department of the Army Special Security System (Washington, DC: Department of the Army, Sep 1991); In a regulatory context, the only mention of "senior intelligence officer" is in the special security programs. Also, of particular note is that the term "senior intelligence officer" only appears once in joint doctrine (JP 2.01), and only in the context of special security; also, the only Army doctrinal manual that contains "senior intelligence officer" (or its functional equivalent) is FM 34-1.

<sup>66</sup> FM 101-5, Staff Organization and Operations (Washington, DC: Department of the Army, 1997); the G6 (signal) is the only staff functionary who approaches the concept of seniority. He is responsible for managing and controlling use of information network capabilities and network services from the power projection sustaining base to the forward most fighting platform. In the author's estimation, the signal community may be preparing to inflict the same disunity on themselves as the MI community currently experiences. It is also interesting to note that this "staff control" phenomenon only exists in the two most information-intensive branches.

<sup>67</sup> FM 34-1, p. 4-2.

<sup>68</sup> MG Charles Thomas, Telephone Interview (Commander, U.S. Army Intelligence Center and Ft. Huachuca, 30 Sep 97).

<sup>69</sup> Jeffrey S. Harley, Memorandum for LTC Marchand, Subject: ACE/DICE/ALOC Manning at 104th MI Battalion (Fort Carson, CO: S3, 104th MI Battalion, 4th Infantry Division (Mechanized), 9 Jan 95).

<sup>70</sup> FM 34-1, p. 4-2, 3.

<sup>71</sup> Ibid., p. 4-11.

<sup>72</sup> Thomas interview.

<sup>73</sup> FM 34-1, p. 3-3.

<sup>74</sup> Ibid., p. 4-2,3.

<sup>75</sup> Stewart, Operation Desert Storm, p. 27, 32.

<sup>76</sup> Ibid., p. 30-32; these trends had a direct impact on the development of prescriptive features of force projection military intelligence that the author uses as evaluation criteria. The current version of 34-1, then, was written to encompass the two realities at once: the current reality of the CEWI-based division MI

model, and the reality of the requirement to move to an information-based, force projection army.

<sup>77</sup> LTG Frederick M. Franks, Jr., After Action Review Comments (Al Bwsayah, Commander, U.S. Army VII Corps, Mar 91); per 1st hand account, Franks made this comment in relation to 2ACR reliance on JSTARS during a point in the battle. In this particular case, JSTARS could not fly due to software problems. OV-1Ds had to be "scrambled" to cover the unprogrammed gap.

<sup>78</sup> Author's note - the ACE was conceptually discussed in the 1988 Army Intelligence Master Plan, and the 24th Infantry Division (Mech) had re-organized to an unofficial ACE architecture in this timeframe. To the best of the author's knowledge, the 24th was the only unit to use the ACE concept during Desert Storm.

<sup>79</sup> TRADOC Pamphlet 525-5, p. 2-8.

<sup>80</sup> *Ibid.*, p. 2-7.

<sup>81</sup> *Ibid.*, p. 2-11.

<sup>82</sup> Gary E. Phillips, Memorandum for USAIC & FH, ATTN: DOTD, Fort Huachuca, AZ, Subject: Review of FM 34-25-3, All Source Analysis System, Initial Draft, September 1993 (Fort Carson, CO: Headquarters, 104th MI Battalion, 4th Infantry Division (Mechanized), 12 July 94).

<sup>83</sup> FM 100-5, p. 2-12.

<sup>84</sup> Was de Czege interview; Was de Czege stated that he was specifically opposed to eliminating the G2 as the senior intelligence officer. In his view, the Army has significantly diminished the role of the staff at large, assuming a number of planning and coordination roles under the rubric of "command advocacy." In the context of the G2, he specifically states "there is a difference between the commander's alter ego (the G2), and a leader of people and manager of assets (the MI Battalion commander). This leader, by virtue of personality, physical capability, span of control, etc., may not be the best guy to help the division commander think through the enemy problem. That's what the G2 is for." In the author's estimation, there are three distinct weaknesses to Was de Czege's argument: 1) The advent of information as combat power, coupled with the ability to gain and maintain information overmatch against a potential adversary, warrants the consideration of an intelligence operator to apply this combat power as well as advise the commander on its use. 2) The senior intelligence officer is primarily a facilitator of a learning organization, vice a senior analyst. He enables his compliment of trained analysts toward a shared vision, a common mental model, and team learning. 3) The best G2's have invariably been or will be MI battalion commanders, and visa-versa.

<sup>85</sup> Peter M. Senge, The Fifth Discipline: The Art and Practice of the Learning Organization, (New York, NY: Doubleday, 1990), p. 140; Senge makes these comments in the context of building a learning organization, which, according to Sullivan, is at the root of the development of a knowledge-based force.

<sup>86</sup> Boyd L. Dastrup, King of Battle: A Branch History of the U.S. Army's Field Artillery, (Fort Monroe, VA: U.S. Army TRADOC, 1993), p. 128.

<sup>87</sup> *Ibid.*, p. 128-9.

<sup>88</sup> *Ibid.*, p. 134.

<sup>89</sup> *Ibid.*, p. 140-1.

<sup>90</sup> *Ibid.*, p. 141.

<sup>91</sup> *Ibid.*, p. 146-7; Theoretically based wisdom was also giving way to practical experience. According to Dastrup, European armies, aware that the Russo-Japanese war demonstrated the need for howitzers to hit targets on reverse slopes and in trenches, slowly integrated howitzers into the division's field artillery to complement their guns."<sup>91</sup>

<sup>92</sup> *Ibid.*, p. 150-1.

<sup>93</sup> *Ibid.*, p. 176.

<sup>94</sup> *Ibid.*, p. 195; Commanded by a brigadier general, the original division artillery had 144 officers and 2439 enlisted personnel and was composed of three 75mm gun battalions (36 guns apiece) for direct support of each maneuver brigade, and one 155mm howitzer battalion for general support.

<sup>95</sup> *Ibid.*, p. 200-201; 203-204; Of particular note is the impact and integration of lessons learned from the Spanish Civil War and the German Invasions of Poland and France. In analyzing the narrow view of each branch at this time, "Like the war department, the (FA) officers did not integrate tanks, infantry, and field artillery into formations as the Germans were developing with Blitzkrieg warfare or as B.H. Liddel Hart or J.F.C. Fuller were promoting in Great Britain to avoid positional warfare along the lines of the Great War. As a result, the Field Artillery failed to develop tactics to support armored thrusts. Creating an effective

team of field artillery, infantry, armor, and air power did not come until the War Department and field artillery had digested the lessons of the Spanish Civil War. Realizing that close cooperation between field artillery and the other combat arms was paramount, the Germans assigned radio-equipped forward observers to the leading armor and infantry elements to direct fire. They sometimes kept their guns so close to the front that gun crews frequently had to use direct fire. They also attached an artillery battalion to an armor or infantry regiment, and allowed their artillery battalions to operate independently of each other. Because of these practices, the Germans generally massed their field guns only for breakthroughs or when resistance stiffened.”

<sup>96</sup> Ibid., p. 197; Experiments as early as 1932 established the viability of a (FDC) to centralize computing firing data at the battalion. The center...would prep firing data and synchronize fire on the most dangerous target; allowing “the battalion to shift fire rapidly to mass on a single target and deliver a hammer blow....”

<sup>97</sup> Ibid., p. 198-9; Dastrup notes that immense friction initially arose against the advent of the FDC. Senior FA officers, drawing on their experience as battery commanders, felt that the battery commander was “a king in his own right, and that no one but the battery commander could give orders.” Ironically, the Chief of the field Artillery, MG Upton Birnie, Jr., was the greatest obstacle. He wanted to keep link from FO to battery, opposed the FDC, and claimed that massing effects from battalion on one target was not practical. A compromise would be achieved later by placing responsibility for observed fires at battery, unobserved fires at battalion, and allowing the fire direction center to centralize computations.

<sup>98</sup> Ibid., p. 210-1.

<sup>99</sup> Ibid., p. 258.

<sup>100</sup> Ibid., p. 259.

<sup>101</sup> Ibid., p. 294-6; Per Dastrup, the enabling technologies that allowed the FIST to come into being included computers, laser target acquisition and designation, and precision guided munitions. These capabilities would also result in the outgrowth of combat operation laser teams (COLT).

<sup>102</sup> James J. Schneider, “Black Lights: Chaos, Complexity, and the Promise of Information Warfare,” *Joint Force Quarterly* no. 15 (Spring 97), p. 27; Schneider states that “Since information has the physical dimension of mass it must be extracted, processed, and distributed like other material resources.”

<sup>103</sup> Douglas A. MacGregor, *Breaking the Phalanx: A Design for Landpower in the 21st Century* (Westport, CT: Praeger Publishers, 1997), p. 66-71; The author borrows the term “flatten” from MacGregor to describe the need to reduce the levels of redundancy in command and control inherent in the current command and control model that MacGregor so aptly criticizes. On this fundamental point, the author and MacGregor both agree; the author, however, believes that this flattening should take place at the corps level, thus preserving the division as the fundamental combined arms building block.

<sup>104</sup> Thomas interview; MG Thomas laments that the current ACE serving divisions and corps is too small for 24-hour operations. He further states the “the ACE/ACT in its current state...gives us a reach-back capability, but the next part is to make the ACT a substructure of the DS company, so that it does at brigade what the ACE does at division.”

<sup>105</sup> Ibid.; MG Thomas notes that the enormous database requirement placed on force projection ACE as a key MI readiness factor. FM 34-1 comment on readiness of the MI force fully support this perspective. Also, refer to notes 49 and 56 for a discussion of the need for creating a more ergonomically correct information-based force.

<sup>106</sup> MDCI is the intelligence discipline of systematically finding and exploiting or destroying enemy sensors.

<sup>107</sup> David M. Glantz, *The Fundamentals of Soviet “Razvedka”* (Fort Leavenworth, KS: Soviet Army Studies Office, 1989), p. 4; Glantz expands on this thought: “The English language...applies distinctive terms such as “intelligence” and “reconnaissance” to describe collection and analysis of information concerning the enemy at various levels. Soviet and U.S. terminology differ more than just semantically. The Soviets view razvedka as a single process encompassing mundane actions at the lowest combat level as well as highly sophisticated procedures used at the national level to collect and process information on enemies or potential enemies.” The author’s view of this statement is that the Soviets have always appreciated information as combat power, and were cognitively and organizationally prepared to fight the information war (in the context of conducting operational art) long before the information technology explosion catalyzed by the microchip and personal computer. Glantz further elaborates on definitions: “Soviet razvedka treats reconnaissance as the process and intelligence as the product. The two are closely

---

interrelated and equally important, and only context distinguishes between them. The Soviets (in the Soviet Military Encyclopedia) define military razvedka as the obtaining, collection, and study of data about military-political conditions in individual countries and in probable or actual enemy coalition nations; their armed forces and military-economic potential; the compositions, dispositions, condition, nature of actions, and intentions of groups of forces; and also about the theater of operations." (Glantz, p. 4)

<sup>108</sup> FM 100-2-1, The Soviet Army Operations and Tactics (Washington, DC: Department of the Army, 1984), p. 3-5.

<sup>109</sup> Ibid., p. 3-8, 7-1.

<sup>110</sup> Glantz, The Fundamentals of Soviet "Razvedka." p. 9.

<sup>111</sup> V.G. Reznichenko, Soviet Union Military Affairs: Tactics (Tactika) (Moscow, USSR: Russian Voyendizdat, 1987. Translated by the Foreign Broadcast Information Service, 1988), p. 55.

<sup>112</sup> The author personally participated in Prairie Warrior 96 (as a project officer for the US Army Intelligence Center) and Prairie Warrior 97 (as a CGSC student). The RSTA TOC was used in the Mobile Strike Force (a division-level reproduction of the Force XXI division developed at Ft Hood) in 96. The extensive use of ASAS in a division level ACE and in brigade level ACTs, combined with the organizational effect of the RSTA TOC, greatly contributed to the ability to dynamically conduct "MI gunnery" - quickly placing assets at all levels to bear on key intelligence requirements. The results of this endeavor were lauded by nearly all of the senior observers. 97 would not see the implementation of the RSTA TOC (for a number of reasons that do not bear on this study), much to the chagrin of a number of officers who had also used it with good results while supporting NTC rotations.

<sup>113</sup> FM 100-6, p. v.

<sup>114</sup> J.F.C. Fuller, Lectures on F.S.R. III (London: Sifton Praed and Co., LTD, 1932), p. ix.

<sup>115</sup> Ibid., p. x.

## BIBLIOGRAPHY

### BOOKS

- Beniger, James R. The Control Revolution: Technological and Economic Origins of the Information Society. Cambridge, MS: Harvard University Press, 1986.
- Bradley, Omar N. A Soldier's Story of the Allied Campaign from Tunis to the Elbe. New York, NY: Henry Holt and Company, 1951.
- Builder, Carl H. The Masks of War: American Military Styles in Strategy and Analysis. Baltimore, MD: Johns Hopkins University Press, 1989.
- Clausewitz, Carl von. On War. Princeton, NJ: Princeton University Press, 1984.
- Dastrup, Boyd L. King of Battle: A Branch History of the U.S. Army's Field Artillery. Fort Monroe, VA: U.S. Army TRADOC, 1993.
- Fuller, J.F.C. Lectures on F.S.R. III. London: Sifton Praed and Co., LTD, 1932.
- Greenfield, Kent R., Palmer, Robert R., Wiley, Bell I. The Organization of Ground Combat Troops. Washington, DC: Historical Division of the United States Army, 1947.
- Glantz, David M. The Fundamentals of Soviet "Razvedka". Fort Leavenworth, KS: Soviet Army Studies Office, 1989.
- MacGregor, Douglas A. Breaking the Phalanx: A Deign for Landpower in the 21st Century. Westport, CT: Praeger Publishers, 1997.
- Reznichenko, V.G. Soviet Union Military Affairs: Tactics (Tactika). Moscow, USSR: Russian Voyendizdat, 1987. Translated by the Foreign Broadcast Information Service, 1988.
- Ridgway, Matthew B. The Korean War. Garden City, NY: Doubleday, 1967, p. 13-14.
- Senge, Peter M. The Fifth Discipline: The Art and Practice of the Learning Organization. New York, NY: Doubleday, 1990.
- Sullivan, Gordan R. Into the Twenty-First Century. Cambridge, MA: The Institute for Foreign Policy Analysis, Inc., 1993.

Toffler, Alvin and Heidi. War and Anti-War: Survival at the Dawn of the 21st Century. New York, NY: Little and Brown Company, 1993.

Van Creveld, Martin. Command in War. Cambridge, MS: Harvard University Press, 1985.

Van Deman, Ralph H. The Final Memoranda: Major General Ralph H. Van Deman. Wilmington, DE: SR Books, 1950.

#### ARTICLES

Liddel-Hart, B.H. "Armament and its Future Use." The Yale Review 19 (1930): 649-667.

Phillips, Gary E. "Intelligence to the Point of the Spear." Military Intelligence 21 no. 2 (Apr-Jun 95): 22-24.

Schneider, James J. "Black Lights: Chaos, Complexity, and the Promise of Information Warfare." Joint Force Quarterly no. 15 (Spring 97): 21-28.

#### GOVERNMENT DOCUMENTS

Army Regulation 380-28, Department of the Army Special Security System. Washington, DC: Department of the Army, Sep 1991.

Army Vision 2010. Washington, DC: Department of the Army, 1996.

DoD S-5105.21-M-1, Sensitive Compartmented Information Administrative Security Manual. Washington, DC: Department of Defense, Mar 95.

FM 34-1, Intelligence and Electronic Warfare Operations. Washington, DC: Department of the Army, 1994.

FM 71-100, Division Operations. Washington, DC: Department of the Army, 1996.

FM 100-5, Operations. Washington, DC: Department of the Army, 1993.

FM 100-6, Information Operations. Washington, DC: Department of the Army, 1996.

FM 100-2-1, The Soviet Army Operations and Tactics. Washington, DC: Department of the Army, 1984.

FM 101-5, Staff Organization and Operations. Washington, DC: Department of the Army, 1997.

Harley Jeffrey S. Memorandum for LTC Marchand, Subject: ACE/DICE/ALOC Manning at 104th MI Battalion. Fort Carson, CO: S3, 104th MI Battalion, 4th Infantry Division (Mechanized), 9 Jan 95.

JP 1-02m, DoD Dictionary of Military and Associated Terms. Washington, DC: The Joint Chiefs of Staff, 23 March 1994.

JP 2-0, Intelligence Support to Joint Operations. Washington, DC: The Joint Chiefs of Staff, 5 May, 1995.

JP 3-0, Doctrine for Joint Operations. Washington, DC: The Joint Chiefs of Staff, 1 February 1995.

Keaney, Thomas A., and Cohen, Elliot A. Gulf War Air Power Survey Summary Report. Washington DC: US Government Printing Office, 1993.

Phillips, Gary E. Memorandum for USAIC & FH, ATTN: DOTD, Fort Huachuca, AZ, Subject: Review of FM 34-25-3, All Source Analysis System, Initial Draft, September 1993. Fort Carson, CO: Headquarters, 104th MI Battalion, 4th Infantry Division (Mechanized), 12 July 94.

Stewart, John F., JR., BG. Operation Desert Storm: The Military Intelligence Story: A View from the G-2 3D U.S. Army. Riyadh, Saudi Arabia: 3D U.S. Army, 27 April 1991.

Table of Organization and Equipment, 34395A000, Heavy Division, Military Intelligence Battalion.

Table of Organization and Equipment, 87004F200, Heavy Division, Military Intelligence Battalion (Force XXI).

TRADOC Pamphlet 525-5, Force XXI Operations. Ft. Monroe, VA: U.S. Army TRADOC, 1 August 1994.

US Army, Force XXI... America's Army of the XXIst Century. Ft Monroe: Office of the Chief of Staff, U.S. Army, Director of Louisiana Maneuvers, 1995.

Weinstein, Sidney T. Evolution of Military Intelligence 1944-1984. Ft. Huachuca, AZ: U.S. Army Intelligence Center and School, 3 Jan 1984.

## MONOGRAPHS, THESES, AND UNPUBLISHED WORKS

- Conrad, Stephen C. "The History of Military Intelligence." Individual Study Project. Carlisle Barracks, PA: U.S. Army War College, 1989.
- Franz, George J. "Information--The Fifth Element of Combat Power." Student Monograph. Ft. Leavenworth, KS: School of Advanced Military Studies, 1996.
- Wass de Czege, Huba. "Understanding and Developing Combat Power." Unpublished Paper. Ft. Leavenworth, KS: School of Advanced Military Studies, 1984.

## INTERVIEWS

- Alexander, Keith, COL. J2-P, Joint Chiefs of Staff. Telephone interview conducted 3 Nov 1997.
- Bernardo, Wilma. Force Modernization, Combat Developments, U.S. Army Intelligence Center and FT. Huachuca. Telephone Interview conducted 6 Nov 97.
- Muckelroy, Joseph. Force Modernization, Combat Developments, U.S. Army Intelligence Center and FT. Huachuca. Telephone Interview conducted 30 Sep 97.
- Stutler, Ben. Requirements Documentation Directorate, US Army Combined Arms Center. Personal Interview conducted 27 Oct 97.
- Thomas, Charles, MG. Commander, U.S. Army Intelligence Center and Ft. Huachuca. Telephone interview conducted 30 Sep 97.
- Was de Czege, Huba. Telephone interview conducted 26 Sep 97.
- Weinstein, Sidney T., LTG(R). Electronic Warfare Associates. Telephone Interview conducted 6 Nov 1997.

## SLIDE PRESENTATIONS

- Stutler, Ben. Requirements Documentation Directorate, US Army Combined Arms Center. Slides representing the current A-Series and Force XXI TOEs, 20 June 1997.

SPEECHES

Franks, Frederick M. Jr., LTG. Commander, U.S. Army VII Corps. After Action Review Comments at Al Bwsayah, Mar 91.

Stuart, John F., Jr., BG(P). Commander, US Army Intelligence Center and Ft Huachuca. Speech presented to the intelligence officers of the 82d Airborne Division as part of ASAS new equipment training, 10 Oct 97.

## Appendix 1

### Field Army Military Intelligence Battalion

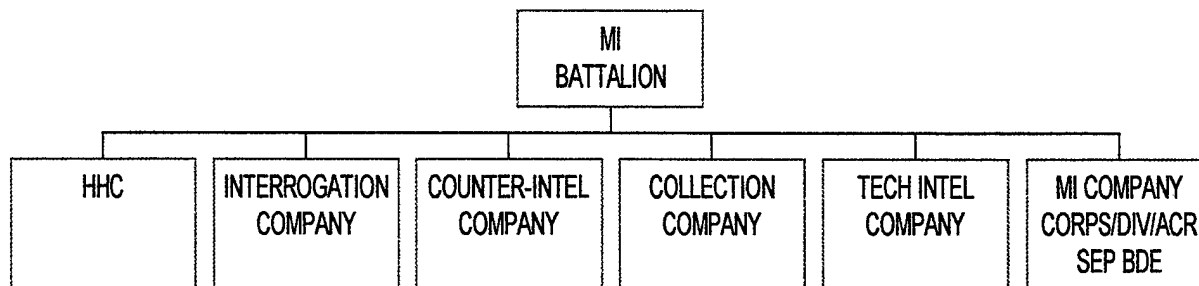

- Basis: FM 30-9, MI Organizations, Mar 68.
- Supported the field army as well as subordinate corps, divisions, armored cavalry regiments, and separate brigades with imagery interpretation, counterintelligence, intelligence collection operations, technical intelligence, analysis, and production.
- Provided technical support to separate military intelligence units attached to corps, divisions, armored cavalry regiments, or separate brigades.
- Divisional MI Company assigned to field army, attached to divisions on a quasi-permanent basis; provided direct support to the G2.
- Total of 92 slots.
- Deficiencies:
  - High percentage of reserve component force structure
  - Inadequate analysis capability.
  - Not all source.
  - No hardcopy communications or high-volume communications.
  - Perceived as “unwanted guests” because of attached status.
- From Weinstein, Evolution of Military Intelligence 1944-1984.

Appendix 2  
Army Security Agency (ASA) Support at Field Army

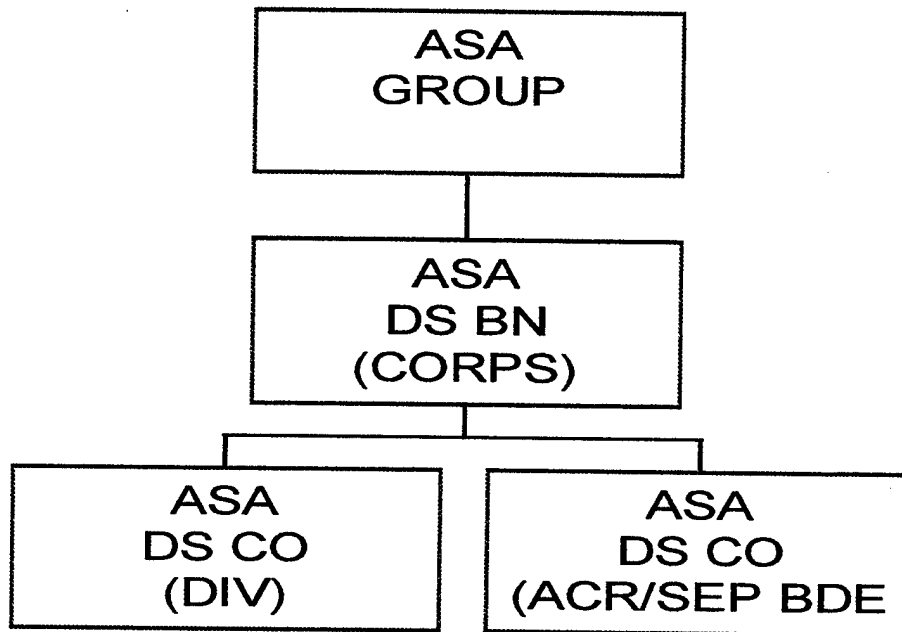

- ASA subordinate units DS to field army.
- Subordinate units but command and control retained by ASA Group at field army.
- Total IEW support to division:
  - Field Army MI Co 92
  - ASA MI Co 219
  - Total 311
- From Weinstein, Evolution of Military Intelligence 1944-1984.

## Appendix 3

### Initial TARS - 75 Battalion Organization Recommendation

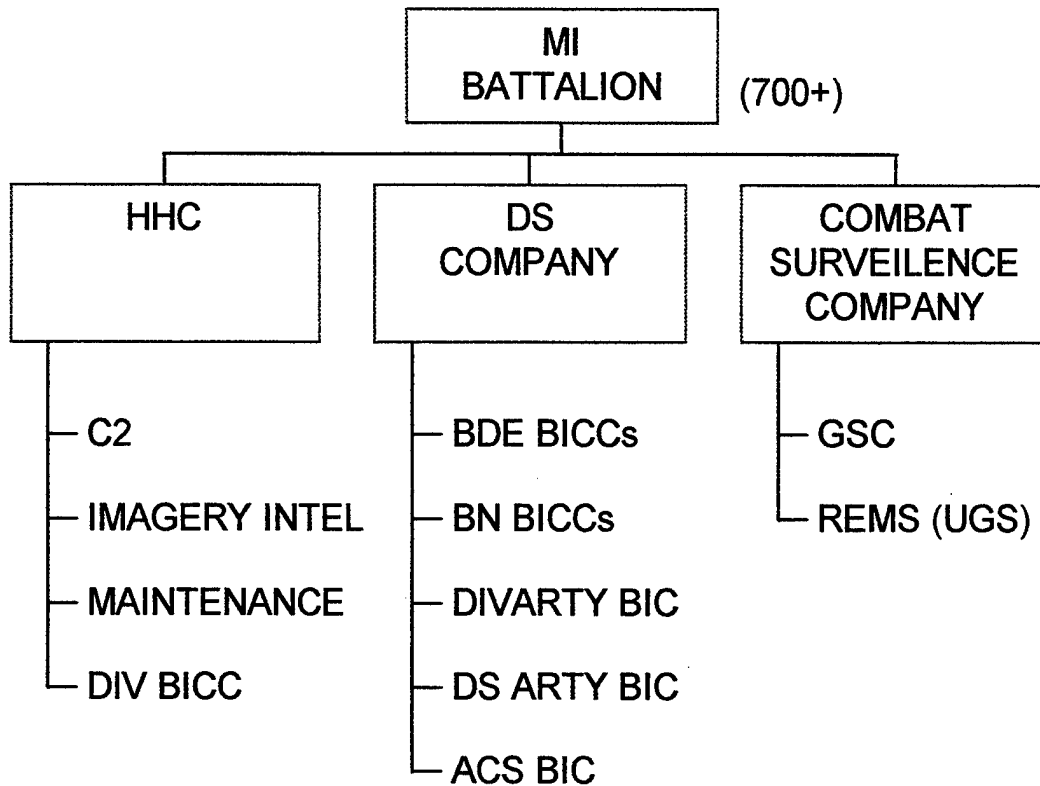

- TARS - 75 directed by Chief of Staff in 1965
- Organic to division
- No CI/Interrogation organic to division
- BICC - battlefield information coordination center
- BIC - battlefield information center
- GSR - ground surveillance radar
- REMS - remotely emplaced sensors
- UGS - unattended ground sensors
- From Weinstein, Evolution of Military Intelligence 1944-1984.

Appendix 4  
Final TARS - 75 Recommendation  
Combat Intelligence (CBTI) Battalion

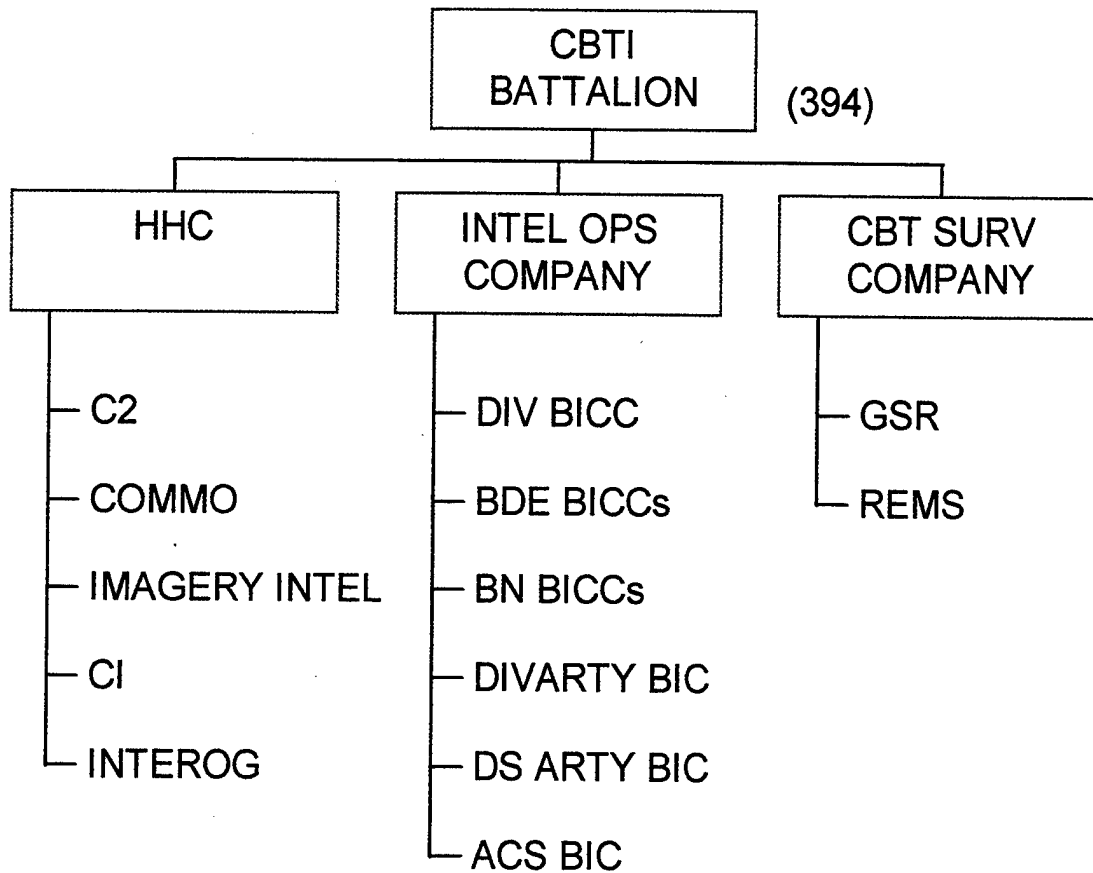

- BICC/BIC primary area of reduction from initial recommendation
- From Weinstein, Evolution of Military Intelligence 1944-1984.

**Appendix 5**  
**Division Combat Intelligence (CBTI) Company**  
**(TOE 30-19H. 1976)**

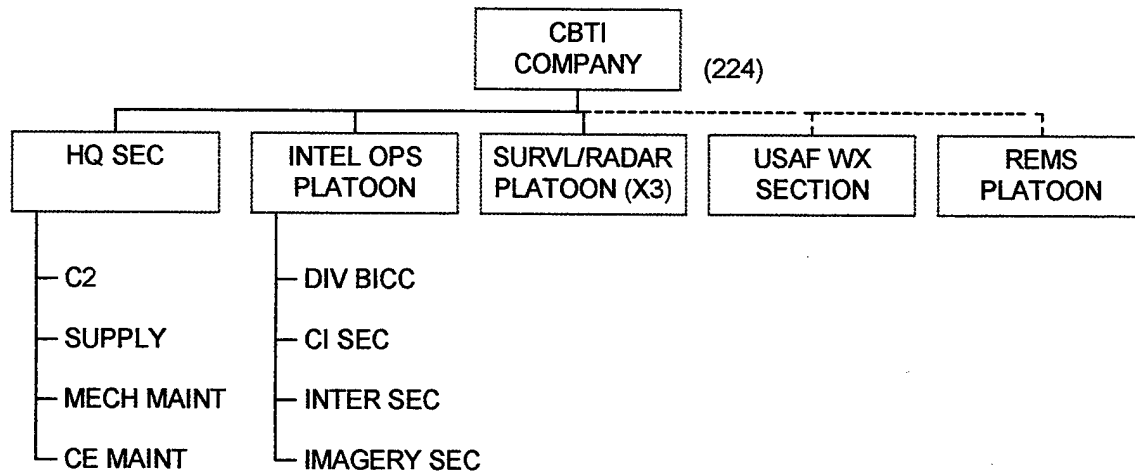

- Formed in lieu of the CBTI Battalion
- All BICC/BIC made organic to units except Division
- ASA Company provided an element in later testing and fielding to division BICC; resulted in the first all-source analysis and production at division.
- ASA Company provides DS support per previous models
- Total IEW support to division:
 

• ASA Company (w/analysis spt)	219
• CBTI Company	224
• total	443 (increase of 132)
- From Weinstein, Evolution of Military Intelligence 1944-1984.

**Appendix 6**  
**Intelligence Organization and Stationing Study (IOSS)**  
**Final Recommendation:**  
**Combat - Electronic Warfare Intelligence (CEWI) Battalion**

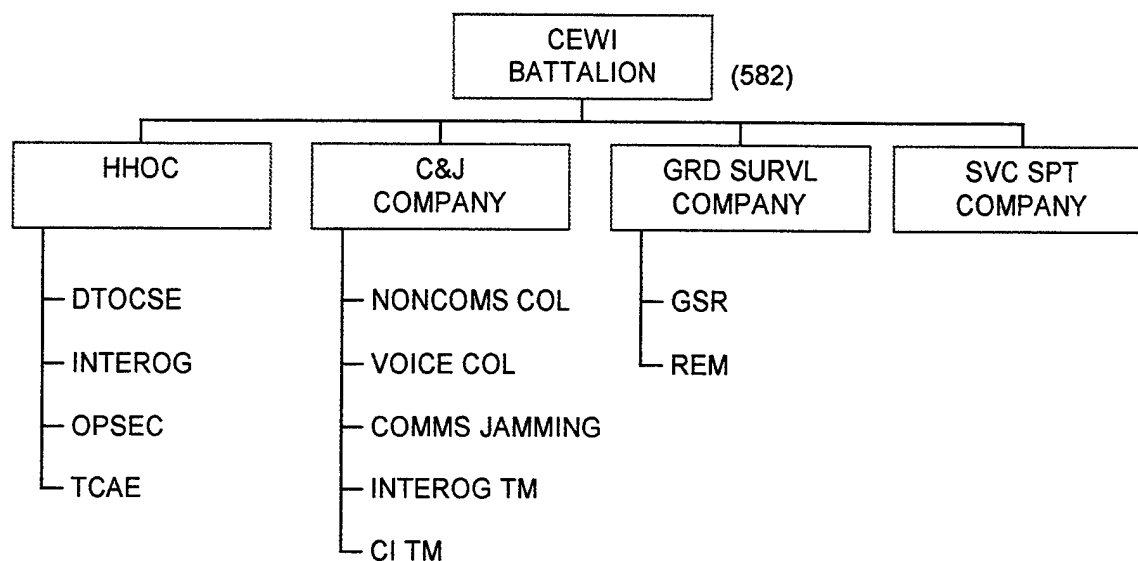

- IOSS directed by Army Chief of Staff Dec 1974
- Proposed consolidation all-source IEW capabilities consolidated under tactical commanders, eliminating duplication.
- Simultaneous establishment of Intelligence and Security Command (INSCOM) to provide support to echelons above corps.
- Consolidated available slots from former ASA and CBTI companies
- DTOCSE - Division TOC Support Element
- TCAE - Technical Control and Analysis Element
- Noncomms - non-communications, specifically radar emitters
- From Weinstein, Evolution of Military Intelligence 1944-1984.

## Appendix 7

### Division 86 CEWI Battalion

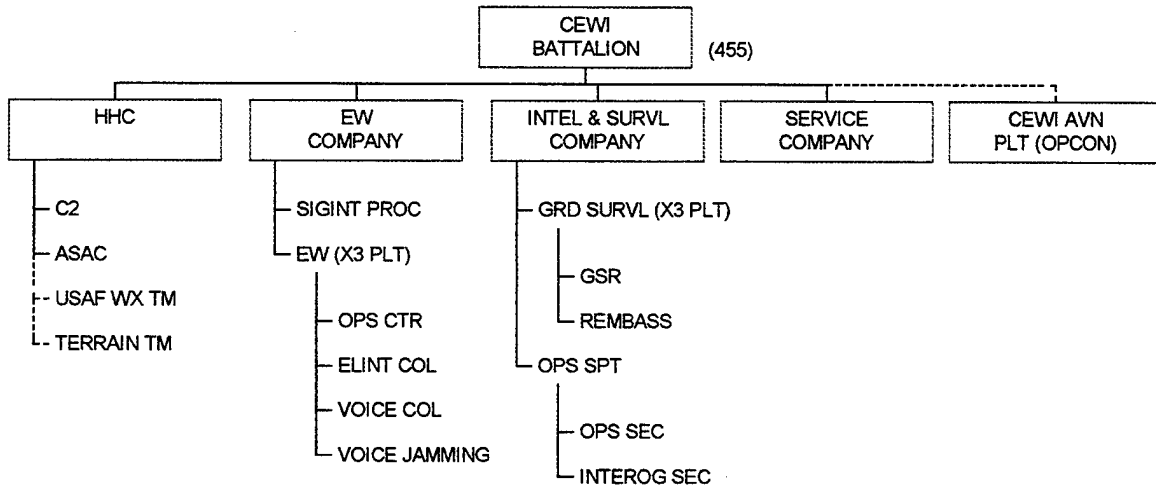

- 1977 Battlefield Development Plan used to identify vital combat functions for future success.
- Army doctrine focus shifting to AirLand Battle as a result of the review of the 1976 version of FM 100-5
- Division 86 developed to meet these requirements
- From Weinstein, Evolution of Military Intelligence 1944-1984.

**Appendix 8**  
**A-Series Division MI Battalion**  
**TOE 34396A000, 1 Apr 94**

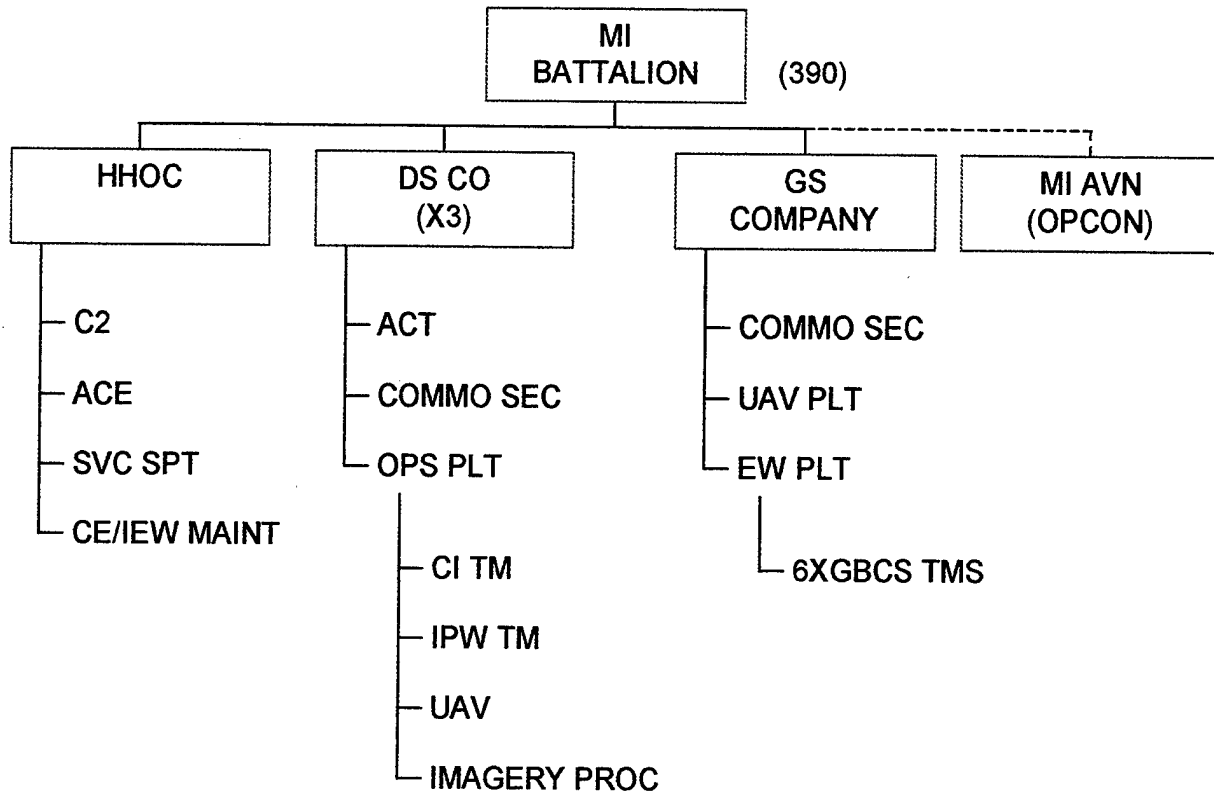

Developed from Table of Organization and Equipment, 34395A000, Heavy Division, Military Intelligence Battalion.

Appendix 9: THE RELATIVE COMBAT POWER MODEL\*

$$Lf(Ff+Mf+Sf-De) - Le(Fe+Me+Se-Df) = \text{The Outcome of Battle}$$

Lf – friendly leadership effect

Ff – friendly firepower effect

Sf – friendly survivability effect

De – enemy degrading of friendly  
(firepower, maneuver,  
and survivability effects)

Le – enemy leadership effect

Fe – enemy firepower effect

Se – enemy survivability effect

Df – friendly degrading of enemy  
(firepower, maneuver,  
and survivability effects)

\*from Wass de Czege, "Understanding and Developing Combat Power."

Appendix 10: THE RELATIVE INFORMATION BASED COMBAT POWER MODEL\*

$$Lf(I_f+Ff+Mf+Sf-De) - Le(I_e+Fe+Me+Se-Df) = \text{The Outcome of Battle}$$

Lf – friendly leadership effect

I<sub>f</sub> – friendly information effect

Ff – friendly firepower effect

Sf – friendly survivability effect

De – enemy degrading of friendly  
(information, firepower, maneuver,  
and survivability effects)

Le – enemy leadership effect

I<sub>e</sub> – enemy information effect

Fe – enemy firepower effect

Se – enemy survivability effect

Df – friendly degrading of enemy  
(information, firepower, maneuver,  
and survivability effects)

\*from Franz, "Information--The Fifth Element of Combat Power."

Appendix 11: THE INFORMATION EFFECT ON THE RELATIVE COMBAT POWER MODEL\*

The knowledge based model does not eliminate any of the base components of the original model. Information effects are added as a fifth component and specific information oriented functions are included. Information functions are also integral to the firepower, maneuver, protection, and leadership elements and are therefore included in those functions as appropriate. There will be some degree of overlap within the information dynamic, as it is one element of combat power that impacts significantly on all the others. The components of the Information Effects function are based on doctrine found in FM 100-6 and FM 34-1.

INFORMATION EFFECT: (which is a function of)

Battle Command: (which is a function of)

- Information Systems Support Capability
  - Span of Control
  - SOPs and Doctrine
  - Staff Efficiency
  - Communications Architecture Efficiency

- Information Environment
  - Information Battlespace
  - Operational Information Environment
  - C4I Equipment Design
  - Crew/Operator Proficiency
  - Rate of Data Processing of Information Systems

Command and Control Warfare Capability: (which is a function of)

- Counter Command and Control (Counter-C2)
  - EW
  - Deception
  - PSYOPS
  - Physical Destruction

- C2 Protection
  - OPSEC
  - INFOSEC
  - Counter-Intelligence

- C2 Integration
  - C2 Employment Doctrine
  - C2 Means

Intelligence Capability: (which is a function of)

Planning and Direction

Commander's CCIR  
IEW Synchronization

Collection Capabilities

HUMINT Capability  
IMINT Capability  
SIGINT Capability  
MASINT Capability  
TECHINT Capability

Information Analysis

Knowledge of the Enemy  
Knowledge of the Terrain  
Knowledge of the Weather

Intelligence Production

All-Source Integration Capabilities  
Production Equipment Design  
Crew/Operator Proficiency  
Rate of Production

Dissemination

Broadcast Capabilities  
Tactical tailoring of Assets

\*from Franz, "Information--The Fifth Element of Combat Power."

Appendix 12  
 F-Series Division MI Battalion  
 TOE 87004F200, 14 May 97

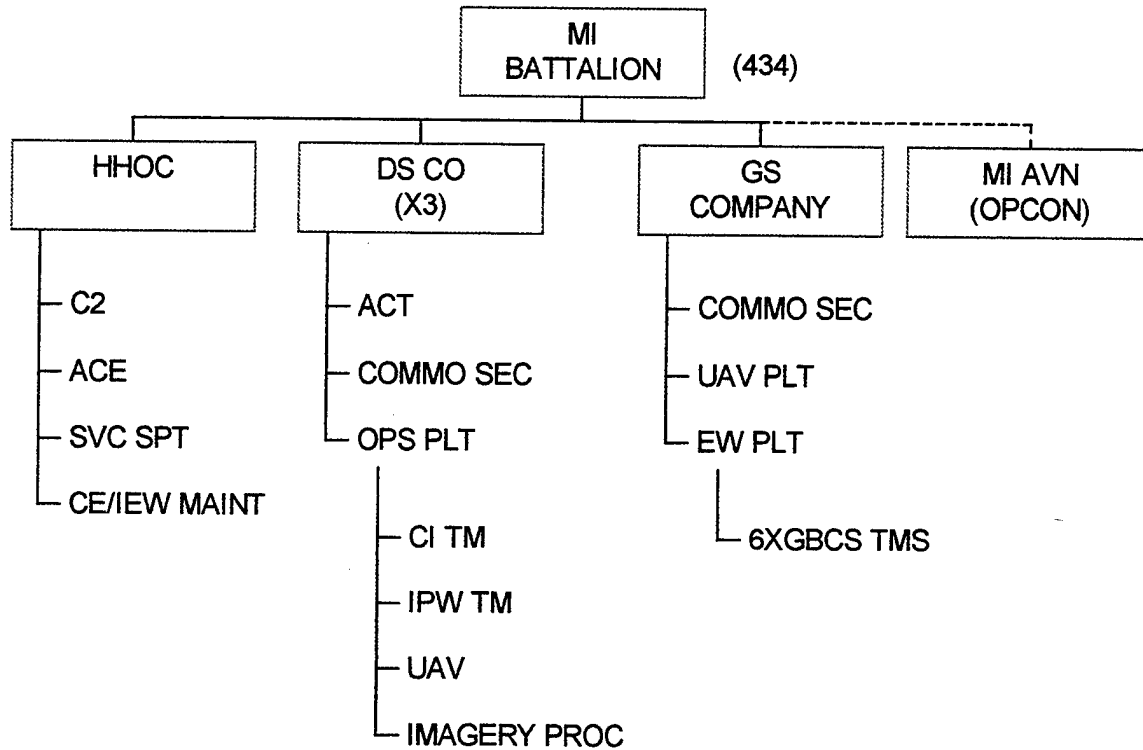

Developed from Table of Organization and Equipment, 87004F200, Heavy Division, Military Intelligence Battalion (Force XXI).

# Appendix 13

## Division Intelligence Command (DIVINT)

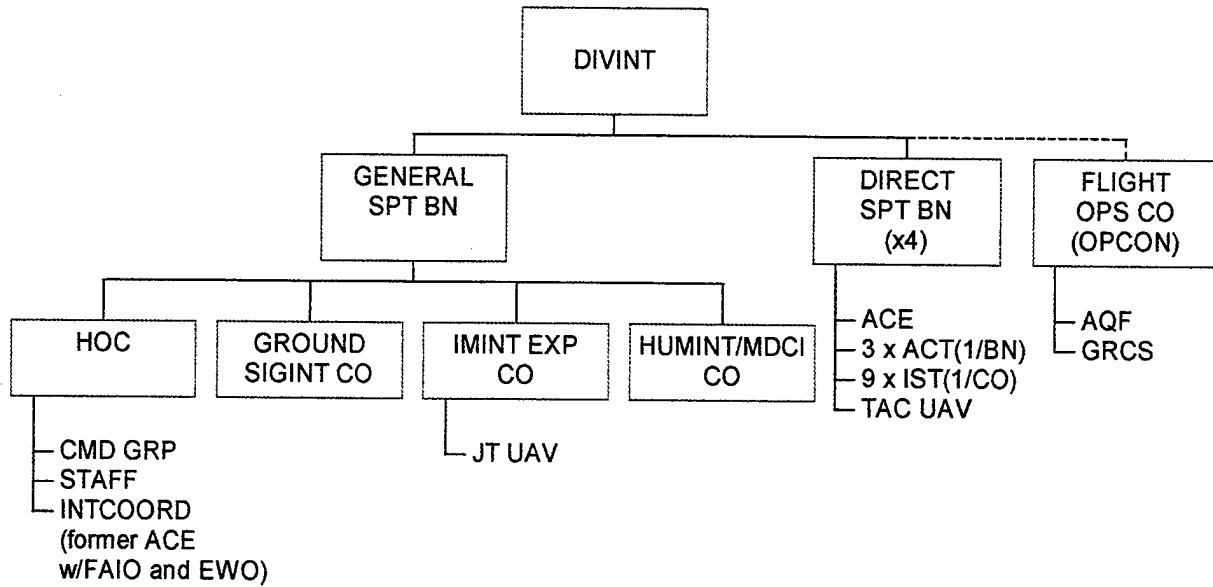

# Appendix 14

## Chief of Reconnaissance Troops (CRT)

