

REPORT DOCUMENTATION PAGE

AFRL-SR-BL-TR-98-

0272

Public reporting burden for this collection of information is estimated to average 1 hour per response, including the time for reviewing this collection of information. Send comments regarding this burden estimate or any other aspect of this collection of information, including suggestions for reducing this burden to Washington Headquarters Services, Directorate for Information Operations and Reports, 4800 Marking Street, Washington, DC 20540-6001, and to the Office of Management and Budget, Paperwork Reduction Project (0704-0188), Washington, DC 20503.

ing and
ition,
ngton,

1. AGENCY USE ONLY (Leave blank)		2. REPORT DATE 5 March 1998	3. REPORT TYPE Final (01 Aug 1994 - 30 Sep 1997)	
4. TITLE AND SUBTITLE Design of Supramolecular Active Sites for Fiber Optic Array Sensing Applications			5. FUNDING NUMBERS F49620-94-1-0170 2303/BS 61102F	
6. AUTHOR(S) Daniel G. Nocera				
7. PERFORMING ORGANIZATION NAME(S) AND ADDRESS(ES) Michigan State University East Lansing, MI 48824			8. PERFORMING ORGANIZATION REPORT NUMBER	
9. SPONSORING / MONITORING AGENCY NAME(S) AND ADDRESS(ES) AFOSR/M 110 Duncan Ave, Room B1K5 Bolling AFB DC 20332-8050 Maj Hugh C. DeLong			10. SPONSORING / MONITORING AGENCY REPORT NUMBER	
11. SUPPLEMENTARY NOTES				
19980331 029				
12a. DISTRIBUTION / AVAILABILITY STATEMENT Approved for public release; distribution unlimited.				
13. ABSTRACT (Maximum 200 Words) This program addressed the diverse chemical and physical sensing needs of the United States Air Force. All the techniques developed in this program are based on monitoring a bright luminescence from a supramolecule, which is composed of molecular subunits connected in intricate ways to create multiple sites of complementary function. For chemosensing applications, a photoactive center of the supramolecule literally lights up when the analyte binds at the remote docking site of the analyte. The photophysics behind such transduction signal schemes has been defined and exploited to develop cyclodextrin-based supramolecules that detect polyaromatic hydrocarbons and alcohols. In addition, the fundamental studies of energy flow in large assemblies placed the program in a unique position to sense important physical phenomena of interest to the Air Force. Specifically luminescent supramolecules were designed and synthesized. These tracers formed the underpinning for a new technique called Molecular Tagging Velocimetry (MTV), which permits vorticity measurements to be made on a variety of important flow problems of concern to the Air Force. One important application of the new technique included measurements of the vorticity in the leading edge of a rotating airfoil.				
14. SUBJECT TERMS sensing, supramolecules, luminescence, environment, velocimetry, pressure sensitive paints, airfoil, energy transfer, optical			15. NUMBER OF PAGES	
			16. PRICE CODE	
17. SECURITY CLASSIFICATION OF REPORT u	18. SECURITY CLASSIFICATION OF THIS PAGE u	19. SECURITY CLASSIFICATION OF ABSTRACT u	20. LIMITATION OF ABSTRACT u	

Executive Summary

The United States Air Force has a variety of environmental sensing needs, both in the chemical and physical worlds. Chemosensing applications involve the detection of chemicals in groundwater near many Air Force Bases and storage facilities. These include the detection of chemical signatures of jet fuels such as JP4, cleaning agents such as TCE and alcohols, oils, and general ground water pollutants including poly-chlorinated biphenyls (PCBs). Beyond the chemical environment, the Air Force faces challenges in sensing physical phenomena, and many of these applications rely on sensing the quantitative motion of fluids. For instance, the design of high performance aircraft (e.g. airfoil and jet engine design) relies on non-intrusive, multipoint velocimetry and pressure measurements of flow fields. In response to the challenges presented by the diverse chemical and physical sensing applications in the Air Force, we develop novel optical techniques.

All the sensing approaches described in this proposal are based on the chemistry of molecules in electronic excited states. Normally residing in dark or ground states, molecules enter excited states when they absorb energy from the environment. Electronically excited molecules are generally very reactive, but they will eventually either return to the original ground state or to a new ground state molecule. The departure of a molecule from its excited state may occur in the absence of a reacting partner (called an intramolecular decay process) or with the help of a second molecule (called an intermolecular decay process).

Figure 1 shows the intramolecular decay processes of an isolated excited state molecule. The overall decay results from competing thermal emission and photon emission pathways described by the radiative and nonradiative rate constants, k_r and k_{nr} , respectively. The radiative rate constant is an intrinsic property of the molecule itself and is related directly to the absorption cross-section [1-3]. The nonradiative rate constant encompasses all decay pathways that do not lead to photon emission. Typically nonradiative decay entails the conversion of the electronic energy of the excited state into high-energy vibrations of the ground state molecule [4-6]. Relaxation to the vibrationally equilibrated ground state molecule is accompanied by the concomitant release of heat, the rate of which is defined by k_{nr} .

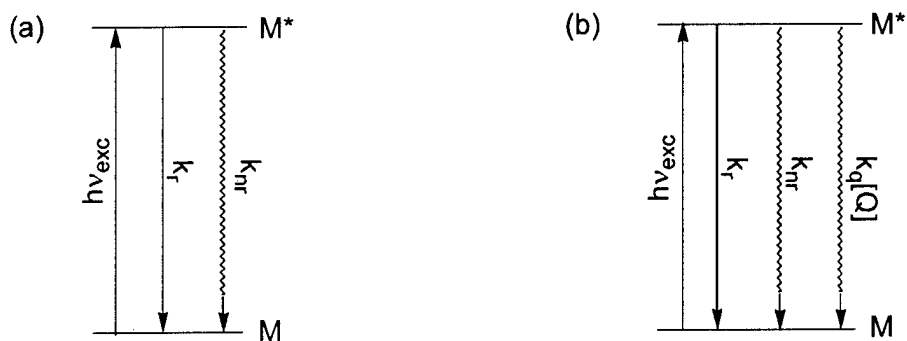

Figure 1. (a) Excited state diagram for (a) intramolecular and (b) intramolecular and intermolecular decay processes of a molecule in an excited state, M^* .

The radiative and nonradiative rate constants are important because they define the fundamental properties of molecules in excited states [1,7,8]. The intensity of luminescence, I_e , is directly dependent on the luminescence efficiency, usually called the emission quantum yield, ϕ_e , which is the ratio of the number of photons emitted per photons absorbed. The emission quantum yield is directly related to k_r and k_{nr} by the following expression,

$$I_o \approx \phi_e = \frac{k_r}{k_r + k_{nr}} = k_r \tau_o \quad (1)$$

where $\tau_o (= (k_r + k_{nr})^{-1})$ is the observed lifetime of the electronic excited state. Usually the nonradiative relaxation pathways dominate, $k_{nr} \gg k_r$, and as can be seen from Eq. (1) molecules remain dark upon excitation. However, when thermal emission is inefficient with regard to photon emission, excited states will literally light up or luminesce.

Eq. (1) only considers the intramolecular decay processes of the excited state molecule in the absence of external reactants. Because electronically excited molecules are highly energetic, they are susceptible to intermolecular reactions in which M^* physically or chemically interacts with species (quencher, Q) in its environment [9] to again return to ground state M (see Figure 1b). The term $k_q[Q]$ accounts for the bimolecular nature of the quenching process and Eq. (1) is consequently modified by adding $k_q[Q]$ to the denominator,

$$I \approx \phi_e = \frac{k_r}{k_r + k_{nr} + k_q[Q]} = k_r \tau \quad (2)$$

where k_q is the quenching rate constant, $[Q]$ is the concentration of the reacting partner and $\tau (= (k_r + k_{nr} + k_q)^{-1})$ is the overall excited state lifetime.

From this formalism, we see that quenching pathways are dissipative and they lead to a diminishment of the luminescence intensity and a shortening of the lifetime. The Stern-Volmer relation quantitatively defines the attenuation in the luminescence lifetime and intensity of M^* by intermolecular decay processes,

$$\frac{I_o}{I} = \frac{\tau_o}{\tau} = 1 + \tau_o k_q [Q] \quad (3)$$

where I_o and I , and τ_o and τ are the luminescence intensity and lifetime in the absence and presence of Q, respectively.

The sensing approached developed in this proposal may be understood in the context of the simple relations defined by Eqs. (1)-(3). All the techniques are based on monitoring a bright luminescence from a supramolecule, which is composed of molecular subunits connected in intricate ways to create multiple sites of complementary function. By controlling the rates for energy conversion (i.e. k_r , k_{nr} and/or k_q) within the supramolecule, the intensity and lifetime of the luminescence may be adjusted for the chemosensing and physical sensing applications of interest to the Air Force. Below is a brief description of the background and accomplishments of our chemosensing and physical sensing work.

1. Chemosensing

1.1. Background for Chemosensing Accomplishments

The ever-increasing need for new capabilities in chemosensing is driven by our demand for higher levels of performance from our advanced technologies and by an increased awareness of the impact of the byproducts from these technologies on the global environment. Of the numerous strategies encompassing sensing schemes, those based on an optical response have assumed a special level of prominence [10,11]. Molecule-based optical schemes can report on nanometer length-scales with nanosecond time responses, continuously monitor analytes and their influences in real time, possess an inherently large bandwidth (and hence information capacity), feature intrinsic selectivity owing to choices of wavelength and polarization, and can be married to a variety of imaging technologies including optical wave guides, the most important of which is optical fibers. Certainly, it is this latter issue that has been the primary driving force behind the emergence of optical sensing schemes in recent years [12-14]. Fiber optic sensors (sometimes called optrodes) permit "wireless" communication between the detection element and the analyte, making it particularly attractive for *in situ* remote sensing applications. Moreover, because signals of many different wavelengths can propagate in either direction within an optical fiber, arrays with multiple sensing capabilities may be constructed. The net result is that fiber optic detection schemes lend themselves to the construction of sensor arrays capable of multiple sensing functions, monitored by a central instrument, in a hostile environment. It is for these reasons that the EPA has identified fiber optic arrays as the forefront optical technology for environmental monitoring and field screening assessments [15], especially for those pollutants in surface and ground water as well as soil.

Three broadly defined components are necessary to the function of a fiber optic sensor: the optical fiber and its associated hardware, matrix in which the active site is immobilized onto the fiber optic and the active site that provides the spectral response upon the recognition of analyte. Most of the science in the development of fiber optic sensors has centered largely about the fiber optic and its associated instrumentation [16]. There has been a veritable explosion of knowledge as to sensing tip configurations, fiber properties, launching optics, light sources and detectors. Less has been learned in regard to matrix supports. Though a variety of matrices has been affixed to optical fiber tips, the matrix microstructure has not been explored with regard to improving transport, selectivity and enhanced performance of the optical fiber sensor. Notwithstanding, the greatest obstacle to the implementation of optical fibers in sensing applications is the lack of active sites tailored to specific sensing function. Whereas there is considerable knowledge on the physical and chemical properties of excited states, which forms a basis for the design of optical sensing schemes, there has been little effort in the design of novel active sites capable of meeting the requirements of selectivity, sensitivity, and stability needed for environmental sensing applications. It is this area of optical fiber sensors that constitutes the focus of this proposal.

Because emitted light is more easily detected than transmitted light, luminescence detection schemes are generally implemented with greater facility than absorption schemes, especially when the signal is proportional to the intensity of the light [17,18]. Many chemosensing schemes detect the presence of an analyte by quenching the luminescence of an active site. Yet quenching pathways are dissipative in nature and lead to a decreased emission intensity from the luminescent active site [9]. Consequently, schemes whose function is derived from quenching mechanisms are hampered by the necessity to detect small differences in luminescence intensity

relative to a high background. In addition, selectivity is compromised because excited states are highly energetic and thus may be quenched by a variety of analytes.

The drawbacks of quenching-based sensing schemes are overcome when an analyte triggers luminescence relative to a dark background. Examples of transduction schemes are few and they are generally described by a similar mechanism, called chelation-enhanced fluorescence (CHEF). In this scheme, charge transfer quenching of a $\pi\pi^*$ excited state of anthracene, naphthalene, or other π -aromatic is interrupted upon the protonation [19] or metal ion chelation of an appended amine [20-22] or upon the displacement of redox active metal ions in crown ethers with inert ions [23,24]. Because neutral substrates do not bind amines well, they are not amenable to detection by CHEF approaches.

A goal of our research in recent years has been to generalize the design of chemosensing schemes based on a triggered luminescence response so that the approach can be used to detect a variety of neutral and charged analytes. Indeed, we have shown that any analyte, irrespective of its absorption and emission characteristics, can be detected by a triggered luminescence response in the visible spectral region. Our strategy, shown in Figure 2, centers on synthesizing supramolecules containing multiple sites of complementary function [25]. At one site is a photoactive center capable of emitting visible light; at the other is a docking site for the analyte. The fundamental parameters governing the luminescence intensity of a photoactive center, as defined by Eq. (2), are manipulated such that molecular recognition of the analyte at the docking site causes $k_r \gg k_{nr}$ and k_q ; this condition is met by increasing the effective k_r , decreasing k_{nr} , or decreasing k_q upon the molecular recognition of analyte by the supramolecule. In this manner, ϕ_e approaches its theoretical limiting value of unity and thus bright luminescence from the photoactive center heralds the presence of an analyte in the supramolecule's environment.

The approach incorporates several noteworthy features. First, the analyte docks to the supramolecule under dynamic equilibrium and, therefore, the overall detection of analyte is a reversible process. The concentration and association constant of the analyte determine how much analyte docks to the supramolecule. These quantities are determined by the steric constraints of analyte within the recognition site, the number of sites to which analyte can anchor, and the nature of the binding pocket (e.g. acidity, hydrophilicity). Second, the energy

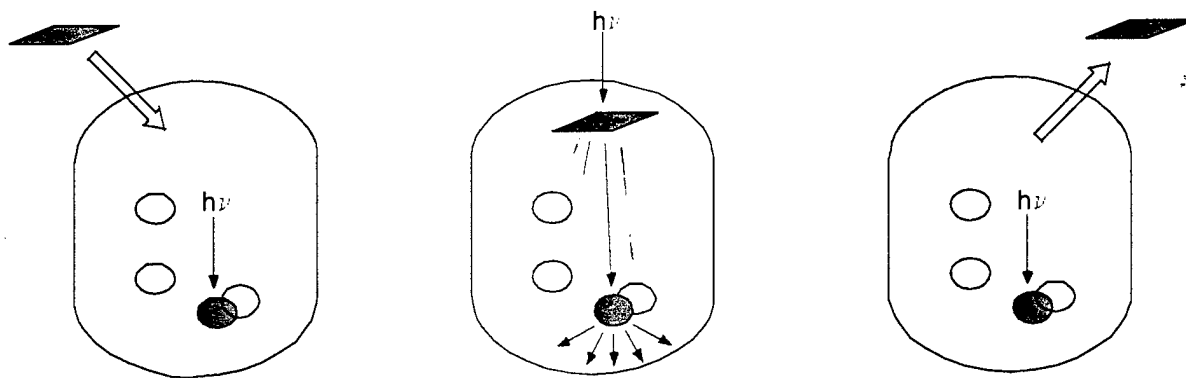

Figure 2. Optical sensing scheme to detect analytes by a triggered luminescence response. The supramolecule is the oval, analyte is the rectangle and the bottom-most oval is the photoactive site. When analyte is not docked in the supramolecule, the photoactive site is dark under irradiation. But when the supramolecule fills itself with a pollutant from the environment, a energy cascade is established leading to a bright luminescence.

flow from the analyte to the photoactive site may be controlled with the electronic coupling of the analyte in the docking site to the photoactive site. To this end, our approach is powerful because high selectivities and sensitivities for a particular analyte can be achieved by manipulating both the excited state properties of the photoactive site and the nature of the docking or binding site. These two factors (i.e. the association constant and energy transfer process) determine the selectivity and detection limit of a particular analyte. Finally, the development of a fiber optic sensor based on the triggered luminescence recognition scheme requires suitable matrix supports to immobilize the supramolecular active sites. Our ability to combine the selectivity and sensitivity of both the active site and matrix support allows us to begin designing chemosensing materials of unprecedented detection capabilities.

During the previous funding cycle we have invested significant efforts to design schemes, based on Figure 2, to detect aromatic hydrocarbons and alcohols. These analytes are conceptually different because the aromatics are capable of absorbing light whereas the alcohols are not. Thus, we have developed two conceptually different triggered luminescence schemes as described below.

1.2. Progress in Chemosensing

1.2.1. Detection of Aromatic Hydrocarbons

One important class of analytes to detect by a triggered luminescence approach are monocyclic (BTEXs – benzene, toluene, xylene, and ethyl benzene) and bicyclic (naphthalene and biphenyl) aromatic hydrocarbons. These harmful chemical pollutants are chemical signatures of the fuel JP4. To date, most optical detection methods of aromatics and polyaromatics rely on measuring the blue fluorescence produced upon direct excitation of the substrate [26]. Practically, laser-induced fluorescence approaches are problematic because the blue fluorescence of the analyte must be deconvoluted from the blue fluorescence of other organic interferents. Recently, a triggered luminescence response has been observed when large polycyclic aromatic hydrocarbons displace fluorophores from DNA [27]. But the low affinity of small cyclic aromatics for DNA has prevented their detection by this method.

Our successful design of an active site for the detection of mono- and bicyclic aromatics by a triggered luminescence response is based on a cyclodextrin (CD) supramolecular architecture. Cyclodextrins are cyclic oligosaccharides, formed from connecting six, seven, or eight D-glucose rings in a head-to-tail arrangement (α -, β -, and γ -, respectively) (Figure 3) to form a molecule shaped like a cup. Hydroxyl groups of the sugar rings encircle the outer rims of the CD cup, imparting water solubility. Conversely, the hydrocarbon rings of the D-glucose subunits define a hydrophobic interior suitable for binding aromatic and hydrocarbon guests. Thus, the cyclodextrin is a miniature cup that dissolves in water but will fill itself with hydrophobic compounds such as benzene or other neutral organic analytes. Each of the three types of CDs have different size cavities that bind only appropriately sized guests molecules. Thus, β -CD will bind the BTEXs (benzene, toluene, ethylbenzene, xylene) but not large polyaromatics such as anthracenes or pyrene, which show an affinity for γ -CD. Consequently, size selectivity in binding (and therefore in sensing) can be achieved with the appropriately sized CD.

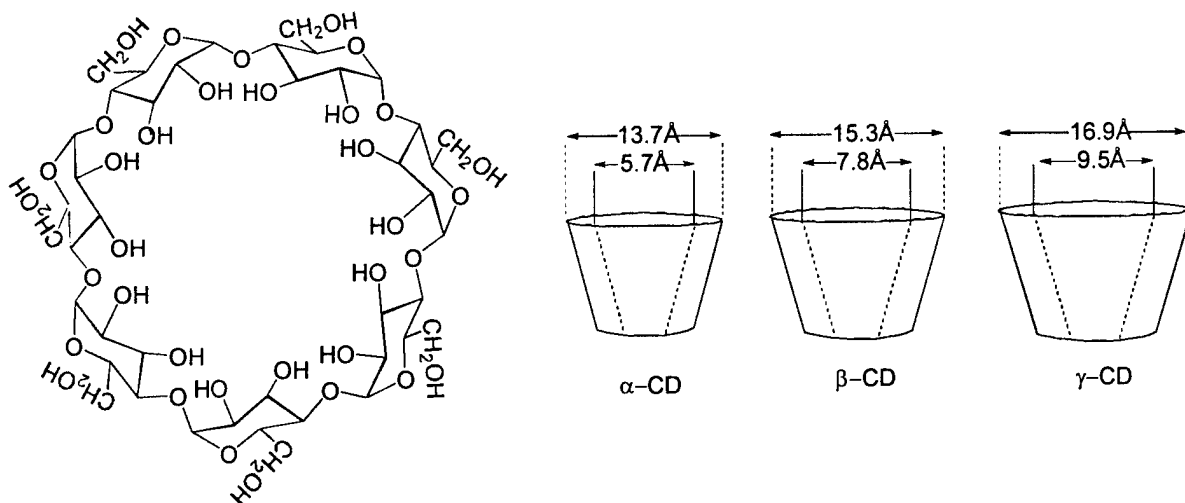

Figure 3. Cyclodextrins are cyclic oligosaccharides containing 6, 7, or 8 D-glucose subunits connected in a head-to-tail arrangement. The dimensions of the cup size is shown for the α -, β -, and γ -CD (6, 7 or 8 D-glucose subunits, respectively).

The CDs by themselves are inadequate optical active sites because they do not possess a photoactive center. This problem is overcome by using the hydroxyl groups at the rim of the CD as handles for photoactive centers such as Eu^{3+} or Tb^{3+} . These lanthanide ions are intrinsically bright lumophores but they show little or no luminescence under direct irradiation owing to the low absorbance ($<1 \text{ M}^{-1} \text{ cm}^{-1}$) of the $^5\text{D}_j$ emitting state manifold [28]. The k_r of the emitting states of Ln^{3+} ions is small and hence the luminescence produced by direct irradiation is weak. Notwithstanding, the emitting state can be indirectly excited with energy from a sensitizer. As popularized by Balzani and Lehn [29,30], an absorption-energy transfer-emission (AETE) process produces the emitting excited state in very high yields as long as the rate of energy transfer rate from sensitizer to the photoluminescent center is efficient. We realized that this AETE process could be useful for chemosensing aromatic hydrocarbons because these analytes have large absorption cross-section with respect to that of the lanthanide ion. We suspected that, under the proper conditions, the aromatic hydrocarbon could absorb the incident light and pass it on to the emitting center. Because the emitting center has a low absorption cross-section, the analyte is employed to indirectly excite the potential latent emitting lanthanide ion. Within the context of Eq. (2), the docking of analyte effectively causes k_r of the lanthanide ion to increase dramatically thus leading to a bright luminescence. However, one additional problem must be solved before lanthanide-based chemosensing schemes may be implemented. Even if Ln^{3+} ions are efficiently excited, their luminescence is quenched efficiently by water because the O—H bonds act as good thermal receptors of the energy of lanthanide-ion excited states [31]. This deleterious effect of water on Ln^{3+} excited states can be overcome by encapsulating the ion in supramolecular swings and cradles, which tie up the coordination sites of the lanthanide ion thereby excluding water.

We have appended the rim with aza swing [32], aza cradle [33] and DTPA-cradle [34] binding sites of Tb^{3+} or Eu^{3+} (Figure 4). The intensity of the triggered luminescence (and hence sensitivity) of these systems depends critically on the binding of the analyte in the CD cup and the efficiency of energy transfer from the hydrocarbon in the cup to the emissive Tb^{3+} or Eu^{3+}

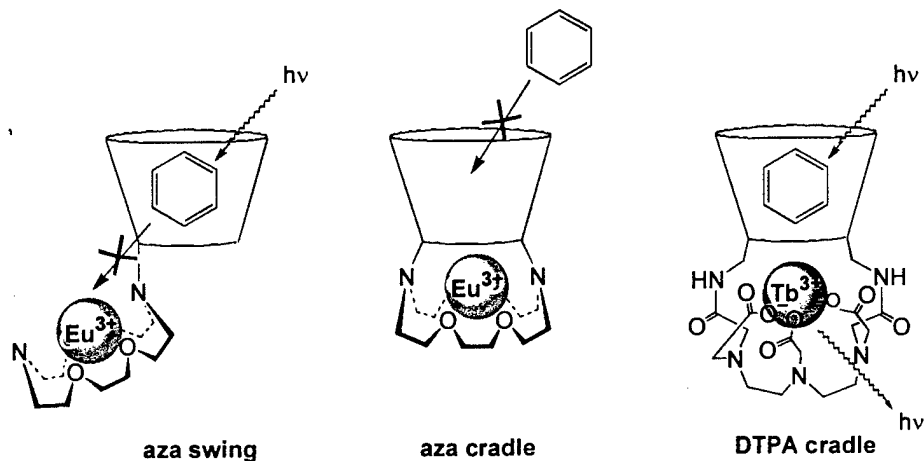

Figure 4. The evolution of design and synthesis toward a cyclodextrin-modified supramolecules that detects, for the first time, mono- and bicyclic aromatics by the visible emission of light.

center. For Eu^{3+} ion residing in the aza swing, a weak red luminescence is triggered upon the molecular recognition of benzene in the hydrophobic interior of the CD cup owing to a long energy transfer distance from benzene to the Eu^{3+} ion (energy transfer has a $1/r^6$ or $e^{-\alpha r}$ dependence). Accordingly, the cradle CD was prepared with the anticipation that the shorter distance imposed by the cradle geometry would result in more efficient AETE. Surprisingly, we observed that the triggered luminescent response from this supramolecular architecture is very weak! In this case, although the intrinsic AETE process is efficient, the association of the benzene to the CD cup limits the overall optical response. The 3+ charge of the appended Eu^{3+} cradle makes the bottom of the cup less hydrophobic and hence decreases the association of benzene in the cup.

These results revealed that our task was to design a binding site in which the 3+ charge of the lanthanide ion could be neutralized. We solved the problem by synthesizing a CD supramolecule appended with the diethylenetriaminepentaacetic acid (DTPA) cradle binding site. We chose the non-reducible, green-emitting, Tb^{3+} as the lanthanide ion for this supramolecule in order to avoid interference from low lying ligand-to-metal charge transfer excited states (which are prevalent for the reducible Eu^{3+} ion).

Very weak emission is observed from aqueous solutions of DTPA-cradle when the metal ion is directly excited owing to the low absorbance of the emitting state manifold. However, the emission from DTPA-cradle is markedly enhanced in the presence of aromatic and bicyclic aromatic hydrocarbons.

Figure 5 shows the titration profiles of the luminescence intensity of the $^5\text{D}_4 \rightarrow ^7\text{F}_5$ transition at 544 nm as a function of the concentration of selected mono- and bicyclic aromatics. The differences in the limiting luminescence intensity between the titrations reflect dissimilar molar absorptivity coefficients of the substrates and different association constants of substrate to the CD cup. In general, the association constants of the aromatics to DTPA-cradle are ~25-fold greater than its binding to β -CD, which is consistent with the enhanced binding of hydrophobic guests to CDs spanned by flexible and rigid caps. Exhaustive photophysical studies show that the triggered luminescence response results from a unimolecular AETE process from the aromatic residing in the CD cup to the Tb^{3+} ion cradled within the appended DTPA binding site.

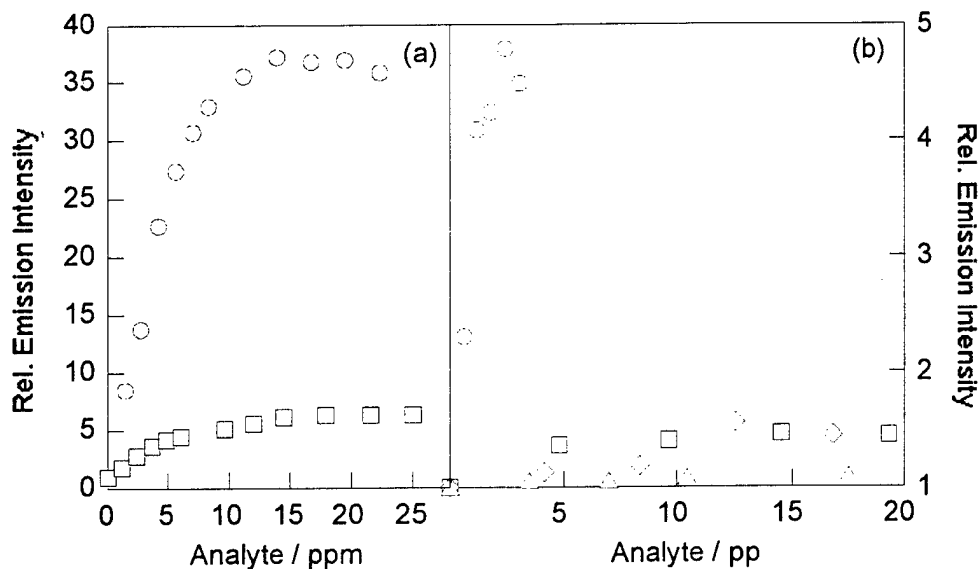

Figure 5. Relative emission intensity of aqueous solutions of DTPA cradle in the presence of selected (a) bicyclic (naphthalene, \circ ; biphenyl, \square) and (b) monocyclic (benzene, \triangle ; toluene, \diamond ; xylene, \square ; durene, \circ) aromatics.

The success of the DTPA cradle in producing bright luminescence in the presence of aromatic substrates is a result of the supramolecule's design. First, the short distance needed for efficient energy transfer in the AETE process is imposed by attaching the DTPA at the (A,D) glucose sites of a β -CD. Second, the three carboxylates of the DTPA cradle neutralize terbium's positive charge, which otherwise interferes with the association of a neutral, apolar guest into the hydrophobic CD cavity. Finally, the dimension of the β -CD cup is commensurate with that of mono and bicyclic aromatics. Larger aromatics may in principle be detected by strapping the DTPA ligand to γ -CD. Conversely, applications desiring the exclusive detection of monocyclic aromatics can be realized with a DTPA-modified α -CD.

Our work in this area has received much attention in the popular press in the past two years as an exciting new approach to monitor the environment. In 1996, the popular science magazine, *New Scientist*, covered our work as a feature article in the January issue [25b]. This magazine is sold on newsstands to the public, with its largest circulation covered in Europe. Within weeks, the BBC picked up the story, and my student, Zoe Pikramenou, discussed our work on a half-hour BBC radio program. The next month, our Air Force work was covered as a feature article for CHEMTECH [25a] as an enabling science for future environmental technologies.

1.2.2. Detection of Alcohols

Alcohols are typically used as solvents for a variety of processing and cleaning applications. They are good target analytes to demonstrate the power of our supramolecular approach because they do not absorb or emit visible or ultraviolet light. Thus detecting alcohols by triggering a luminescence response is represents a significant challenge for this program.

We have successfully detected alcohols with a bright green luminescence by relying on the photophysics of 1-bromonaphthalene (1-BrNp) included within a CD cup. Long-lived and bright green phosphorescence from 1-BrNp is efficiently quenched by oxygen and only blue fluorescence from 1-BrNp is observed. This occurs even when the 1-BrNp is included within the

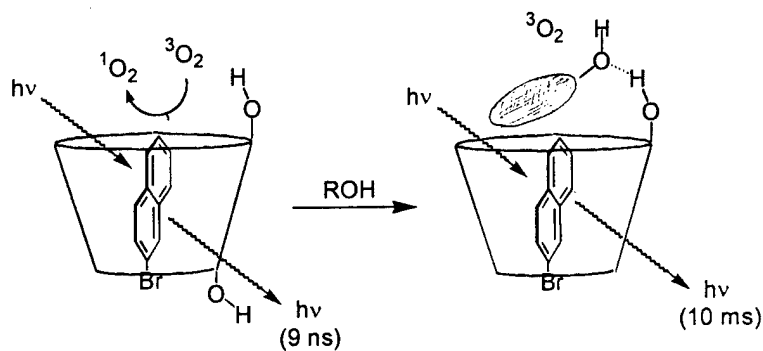
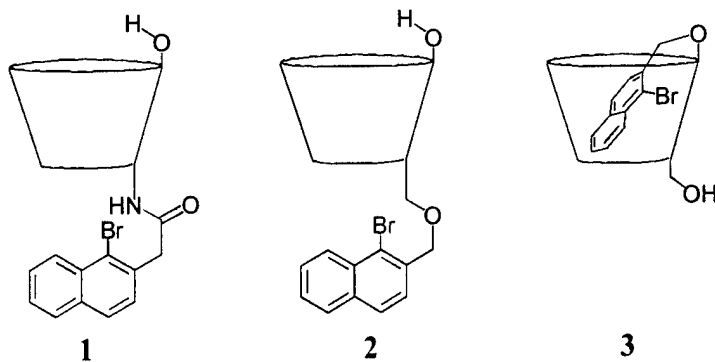

Figure 6. Green, long-lived phosphorescence from 1-BrNp included within a CD is observed only when alcohols are present. In the absence of alcohol, 1-BrNp in CD exhibits only blue fluorescence.

data is shown in Figure 6. The alcohol hydrogen bonds to the rim of the CD cup, and the aliphatic ends of the alcohol flip into or over the hydrophobic interior of the CD. Accordingly, the alcohol acts as a lid for the CD cup thereby shielding 1-BrNp from oxygen. Thus quenching is circumvented and 1-BrNp's intense green phosphorescence is preserved. Enhancements are very large, approaching 10^5 in a triggered luminescent response, depending on the fit of the alcohol lid to the top of the CD cup.

The introduction of the alcohol-sensitive active site into a polymer material coating an optical fiber requires the 1-BrNp to be attached to the CD. Using peptide bond forming chemistry, we have catenated the 1-BrNp to the CD cup (1). However we soon discovered that the presence of the linking amide attenuates the phosphorescence by a charge shift from the nitrogen of the amide to the π^* orbitals of the naphthalene ring. Therefore, we investigated other synthetic strategies to attach 1-BrNp to CD and found that the internal quenching pathway was eliminated with ether linkages.

Accordingly, we prepared regioisomers 2 and 3 where the lumophore is appended to the primary- and secondary-side of β -CD, respectively [36]. The emission spectra of 2 and 3 in aqueous, air-saturated solutions are presented in Figure 7. Whereas both molecules fluoresce at *ca.* 350 nm with nearly equal quantum yields, the phosphorescence of 3 at 530 nm is $>10^2$ times more intense than that observed for an equimolar solution of 2. The disparate luminescence properties of regioisomers 2 and 3 may be ascribed to the latter forming an intramolecular complex in which the appended 1-BrNp is protected from oxygen because of inclusion within the CD cavity. Photo-physical studies show that the secondary side of β -CD is wide enough for the appended 1-BrNp to enter the cavity; the primary side is too narrow for unimpeded intramolecular inclusion to occur. Consequently, only the secondary-side deriva-



interior of a CD. We have found, however, enhancement in the intensity and lifetime of the green phosphorescence of 1-BrNp when a variety of alcohols is added to solutions of CD and 1-BrNp in water. Exhaustive equilibria, photo-physical, and kinetics studies for a series of alcohols [35] reveals that a ternary complex is formed among the alcohol, CD and 1-BrNp. The luminescence mechanism deduced from these

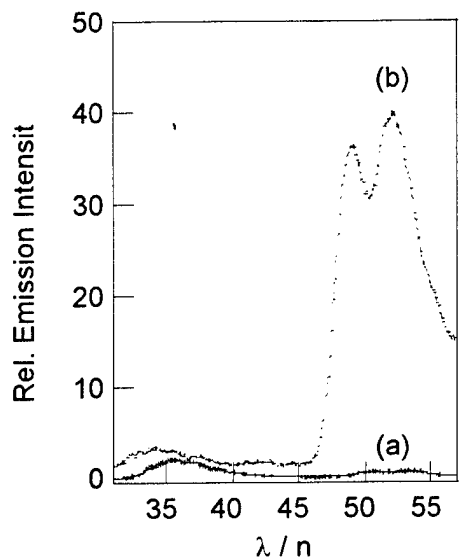

Figure 7. Emission spectra of 1.0×10^{-4} M of (a) **2** and (b) **3** in air-saturated, aqueous solution ($\lambda_{\text{ex}} = 290$ nm).

tive, **3**, forms an intramolecular complex, giving rise to novel room temperature phosphorescence in oxygenated and aqueous environments.

The results of **2** and **3** are important because the synthesis of photoactive CD regioisomers is rare [37] and, until our work, no significant differences had been observed in the photophysics or photochemistry of regioisomeric congeners. An outstanding issue in the design of photoactive CD supramolecules was whether regioisomeric control of reactivity, so prominent in ground state processes [38-40], would be manifested in excited state processes as well. Our results show that excited state reactions of photoactive CDs are subject to regioisomeric control. As described below, such issues will play an especially prominent role in the design of CD-based supramolecules for optical sensing, especially those that derive their function from equilibria of appended lumophores inside and outside the CD cup.

2. Physical Sensing

2.1. Background for Physical Sensing Accomplishments

The success of the optical supramolecules for chemical sensing relies on the luminescence properties to be affected by analyte in the environment. As represented in Figure 2, the light emission properties are proportional to dynamic communication of the supramolecule and the analyte. Ironically, we have discovered a variety of new sensing applications for optical supramolecules when they are insensitive to their environment! By effectively “stitching up” the optical supramolecule, a bright, invariant emission is observed, allowing us to address environmental sensing applications that extend well beyond the world of chemicals. These special active sites form the cornerstone for a new technique invented within this program to precisely describe the chaotic flow of fluids. Specifically, the technique, which we call Molecular Tagging Velocimetry or MTV, measures the velocity flow fields of highly three-dimensional turbulent flows [41].

Turbulence is a fundamental phenomenon in our physical world and optical methods are central to quantitatively measuring the motion of fluids. One of the state-of-the-art optical techniques for measuring fluid flow is particle imaging velocity or PIV [42]. Fluid physicists seed a fluid with millions, sometimes billions, of particles depending on the volume of interest (10,000 particles per cc of fluid). A sheet of laser light illuminates a section of the flow and the reflection of light from the particles identifies their positions. A subsequent laser sheet of light records the particles' positions at a later interval. By comparing the photographs, the particles' positions are correlated with sophisticated computer algorithms thereby reflecting the velocity of the fluid for defined groups of particles. The PIV technique is enormously powerful because it instantaneously measures the velocity of a fluid at many points - a key measurement to any fluid physicist or engineer. Nevertheless, the technique has many drawbacks arising from the need to

measure the flow velocity with particles. First, a plane of light illuminates particles and subsequent illumination relies on the particles staying within the layer so that they may be illuminated at some later time. In highly three-dimensional flows, this will not be the case. Second the particles have their own inertia and they therefore may not track the flow, especially when it changes suddenly. Third, particles may not go into areas of interest. For instance, particles do not go into areas of high turbulence or in areas near surfaces.

Our idea was to replace the particle markers with molecular markers, specifically supramolecules. The requirement for the optical supramolecules for MTV measurements is that they exhibit a bright, non-quenchable luminescence, which is long-lived. The supramolecule tracers are dissolved in the fluid and a grid of laser lines is imposed upon the flow by shining a laser beam off of a grating. A glowing supramolecular grid is produced where the intersections of the grid define points. The glowing supramolecular grid is sufficiently long lived to convect with the flow (μs to ms depending on the fluids problem), which we can image with CCD cameras. The subsequent deformation of the grid is recorded. By measuring the distance and direction each grid intersection travels and knowing the time delay between each image, the two velocity components in the grid plane may be determined by the methods described in Figure 8, and the corresponding turbulence intensities, the Reynolds stress, and the vorticity may be calculated. The technique, which we call MTV (Molecular Tagging Velocimetry), like particle imaging velocimetry, is an instantaneous velocity measurement. But the important difference is that MTV is non-intrusive. Since the supramolecules are part of the flow (they are molecularly dissolved within the flow), all the problems associated with particles are eliminated in the MTV technique.

The trick in implementing the MTV technique is that the grid must exist long enough to permit a luminescent image to move with the flow, thus providing velocimetry information. The design of successful imaging reagents requires a radiative rate in the millisecond time regime and a bright enough to image to capture; therefore, $k_r \gg k_{nr}$ and k_q under all conditions. Because k_r is so slow (i.e., long lifetime), quenching is an issue pervading most measurements. Water, oxygen and residual metals in the environment are good quenchers of luminescence. As described by Eq. (3), the lifetime and intensity of an excited state decrease linearly with increasing concentration of

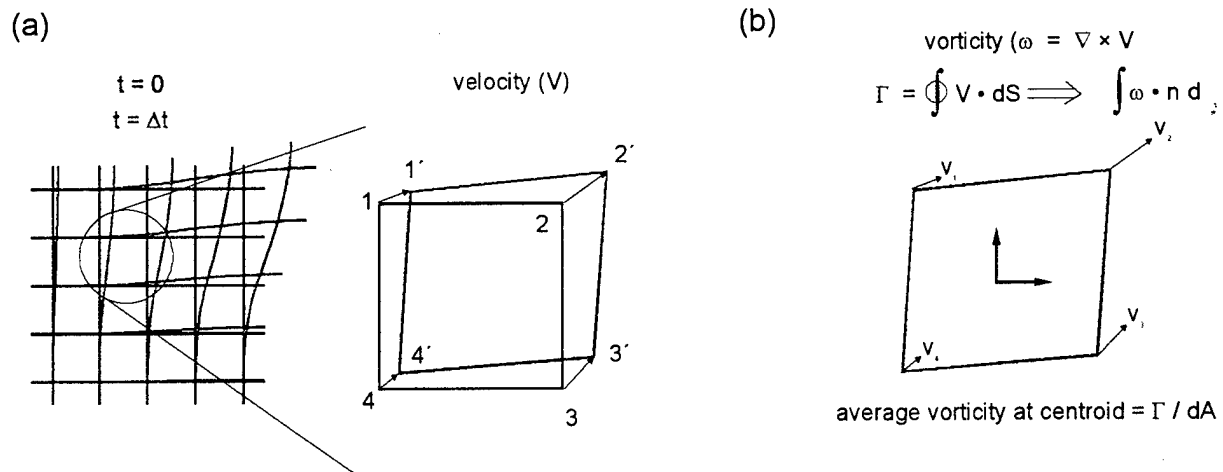

Figure 8. (a) A square grid displacing after time Δt becomes distorted. (b) The vorticity can be determined from the circulation around the grid box by using Stokes' theorem.

these quenchers. Accordingly, a primary challenge in the design of any successful imaging system reduces to molecular designs that minimize these quenching pathways. Unarguably, the most problematic quencher in engineering applications is oxygen owing to its efficiency and prevalence in the environment. Oxygen quenches phosphorescent excited states by the energy transfer mechanism. The problems that oxygen brings to bear to the MTV technique can be explicitly demonstrated by considering Eq. (3). Typically, the quenching rate for oxygen is diffusion controlled (i.e. $k_q = 10^9 \text{ M}^{-1} \text{ s}^{-1}$), and its concentration is 10^{-3} M in solution and 10^{-2} M in air. Thus, according to Eq. (3), the lifetime and intensity of a tracer possessing an inherent 1 ms photoluminescence lifetime will be attenuated by 10^3 in oxygenated solutions and reduced by over 10^4 in air! In our work, debilitating nonradiative decay pathways of potential tracers are identified and the deleterious oscillator or chemical process is then eliminated by targeted synthesis to produce successful optical supramolecule tracers.

2.2. Progress in Physical Sensing

Our design efforts of new tracers centered on water flows, which model several problems of interest to the Air Force where compressibility of the fluid is not an issue. We realized that the ternary complex formed between β -CD, 1-bromonaphthalene (1-BrNp), and the alcohol cap was an ideal tracer in concept because the oxygen quenching is circumvented and the lifetime (10 ms) of 1-BrNp phosphorescence is long, allowing flows as slow as 0.2 to 1 m/s (to ensure linearity, flow displacements are measured for 1 mm) to be measured. Consequently, a systematic study of the system was undertaken with the aim of defining the topological features of the substrate that lead to the best shielding and hence greatest triggered luminescence response [43]. A detailed investigation considering the nature of the hydrogen bonding group, stereochemistry and association constant showed that the best caps comprised a bulky tert-butyl or cyclohexyl group spaced from the functional group of an alcohol or amine by zero or one methylene units. We settled on cyclohexanol as a cap not only because it best covers (see Figure 9) the CD thereby producing one of the brightest phosphorescence yields, but also because this alcohol reduces buoyancy effects resulting from density mismatch between the capping alcohol and water when the tracer is used to investigate mixing.

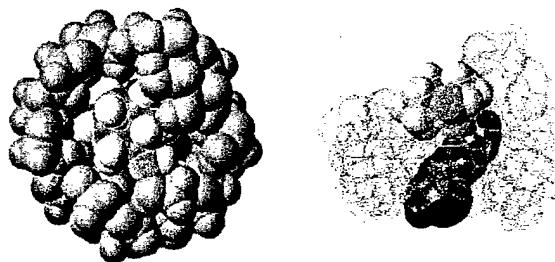

Figure 9. Side and top views of computer-generated molecular models of the tracer formed from 1-BrNp, β -CD and cyclohexanol. The 1-BrNp is purple and the alcohol is green (with oxygen colored red). The CD is speckled for side-on views so that the inside of the cup may be viewed.

The bright phosphorescence is produced only when all components (β -CD, 1-BrNp, and alcohol) of the ternary complex are present. On this basis, we have devised several applications [44]. The components can be pre-mixed for pure velocimetry measurements. Alternatively, the alcohol can be added to one fluid and the β -CD and 1-BrNp to another. Since phosphorescence is observed only when the two fluids are in contact, we are able to molecularly tag a passive scalar mixing

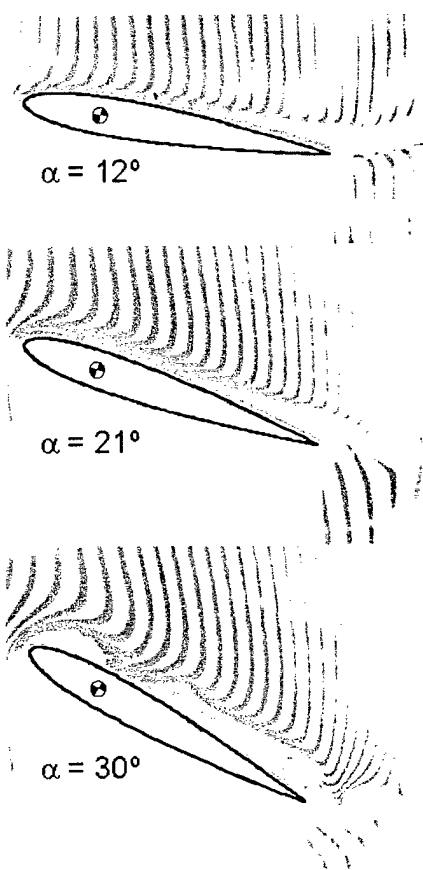

Figure 10. The performance of an airfoil critically depends on the flow field at the wing's leading edge. At small angles of inclination, the flow is "attached". At higher angles, the flow separates and becomes turbulent; the characteristics leading to separation and turbulence at the leading edge are currently under investigation by the MTV technique.

region and or molecularly tag a chemical reacting mixing interface between two streams and observe their Lagrangian evolution.

Our supramolecule design permits us to investigate many problems of interest to the Air Force that previously were elusive to the fluid physicist. One important problem is the flow around airplane wings. The flow is set up at the front or leading edge of the wing. Perturbation of the flow at this leading edge (caused by shear winds, ice or rotation of the wing in highly maneuverable aircraft) causes turbulence and the flow detaches from the wing. This phenomenon for an airfoil as its attack angle is increased is shown in Figure 10. In these situations, the plane loses lift thereby catastrophically affecting the flight of the aircraft. With less dire consequences, when the smooth or laminar flow over a wing becomes turbulent, the drag increases thereby resulting in losses in flying efficiency. This problem is uniquely addressed by the MTV technique owing to its highly three dimensional character and the large range of spatial and temporal scales. Under the auspices of the AFOSR program of Professor Manoochehr Koochesfahani (AFOSR F49620-95-1-0391) in the Department of Mechanical Engineering at Michigan State, the CD/1-BrNp/alcohol system is being used to describe quantitatively the flow at the leading edge [45]. This work is leading to a better understanding of the conditions for which turbulence at the leading edge is minimized and therefore provides insights for the design of safer and higher performance aircraft.

3. Literature Citations

1. Balzani V.; Carassiti V. *Photochemistry of Coordination Compounds*; London: Academic Press, 1970.
2. Forster, L. S. In *Concepts of Inorganic Photochemistry*; Adamson, A. W., Fleischauer, P. D., Eds.; Wiley-Interscience: New York, 1975; pp 1-35.
3. Wayne, R. P. *Principles and Applications of Photochemistry*; Oxford University Press: Oxford, 1980.
4. Jortner, J.; Rice, S. A.; Hochstrasser, R. M.. *Adv. Photochem.* **1969**, 7, 149.
5. Freed, K. F. *Acc. Chem. Res.* **1978**, 11, 74.
6. Lin, S. H. *Radiationless Transitions*; Academic Press: New York, 1980.
7. Turro, N. J. *Modern Molecular Photochemistry*; Benjamin/Cummings: Menlo Park, 1978.
8. Ferraudi, G. J. *Elements of Inorganic Photochemistry*, Wiley-Interscience: New York, 1988; Ch. 1.

9. Balzani, V.; Moggi, L.; Manfrin, M. F.; Bolletta, F. *Coord. Chem. Rev.* **1975**, *15*, 321.
10. *Sensors: A Comprehensive Survey. Fundamentals and General Aspects*; Göpel, W., Hesse, J., Zemel, J. N., Eds.; VCH Publishers: New York, 1988; Vol. 1.
11. Janata, J. *Principles of Chemical Sensors*; Plenum Press: New York, 1988, Ch. 5.
12. *Fiber-Optic Chemical Sensors and Biosensors*; Wolfbeis, O. S., Ed.; CRC Press: Boca Raton, FL, 1991; Vol. 1.
13. *Sensors: A Comprehensive Survey. Optical Sensors*; Wagner, E., Dändliker, R., Spenner, K., Eds.; VCH Publishers: New York, 1991, Vol. 6.
14. Rogers, A. J. In *Sensors: A Comprehensive Survey. Fundamentals and General Aspects, Optical Sensors*; Göpel, W., Hesse, J., Zemel, J. N., Eds.; Plenum Press: New York, 1992; Vol 6, Ch 15.
15. Eastwood, D.; Lidberg, R. L.; Simon, S. J.; Vo-Dinh, T. In *Chemistry for the Protection of the Environment*; Pawlowski, L., Ed.; Plenum: New York, 1991; pg. 91.
16. Thompson, R. B. In *Topics in Fluorescence Spectroscopy*; Lakowicz, J. R., Ed.; Plenum: New York, 1991; Vol. 2, Chap. 7.
17. *Luminescence Applications in Biological, Chemical Environment and Hydrological Sciences*; Goldberg, M. C., Ed.; ACS Symposium Series 383, American Chemical Society: Washington D.C., 1989.
18. *Fluorescence Spectroscopy, New Methods and Applications*; Wolfbeis, O. S., Ed.; Springer-Verlag: Berlin, 1993.
19. Bissell, R. A.; Bryan, A. J.; deSilva, A. P.; McCoy, C. P. *J. Chem. Soc., Chem. Commun.* **1994**, 405.
20. Czarnik, A. W. *Acc. Chem. Res.* **1994**, *27*, 302.
21. Kuhn, M. A. In *Fluorescent Chemosensors for Ion and Molecule Recognition*; Czarnik, A. W., Ed., ACS Symposium Series 538, American Chemical Society: Washington D.C., 1993; Ch. 10.
22. De Santis, G.; Fabbriizzi, L.; Licchelli, M.; Poggi, A.; Taglietti, A. *Angew. Chem., Int. Ed. Engl.* **1996**, *35*, 202.
23. (a) Sousa, L. R.; Son, B.; Trehearne, T. E.; Stevenson, R. W.; Ganion, S. J.; Beeson, B. E.; Barnell, S.; Mabry, T. E.; Yao, M.; Chakrabarty, C.; Bock, P. L.; Yoder C. C.; Pope, S. In *Fluorescent Chemosensors for Ion and Molecule Recognition*; Czarnik, A. W., Ed.; ACS Symposium Series 538, American Chemical Society: Washington D.C., 1993; Ch. 2. (b) Valeur, B., Bourson J. and Pouget, J. *ibid*, Ch. 3. (c) Bissell, R. A.; deSilva, A. P.; Gunaratne, H. Q. N.; Lynch, P. L. M.; McCoy, C. .P.; Maguire, G. E. M.; Sandanayake, K. R. A. S. *ibid*, Ch. 4. (d) Bouas-Laurent, H.; Desvergne, J.-P.; Fages, F.; Marsau, P. *ibid*, Ch. 5.
24. Fabbriizzi, L.; Poggi, A. *Chem. Soc. Rev.* **1995**, *24*, 197.
25. (a) Mortellaro, M. A.; Nocera, D. G. *ChemTech* **1996**, *26*, 17. (b) Nocera, D. G. *New Scientist* **1996**, *149*, 24. (c) Pikramenou, Z.; Yu, J.-a; Lessard, R. B.; Ponce, A.; Wong, P. A.; Nocera, D. G. *Coord. Chem. Rev.* **1994**, *132*, 181.
26. Kumke, M. U.; Lohmannsroben, H.-G.; Roch, T. *J. Fluorescence* **1995**, *5*, 139.
27. Harvath, J. J.; Gueguetchkeri, M.; Gupta, A.; Penumatchu, D.; Weetall, H. H. In *Biosensor and Chemical Sensor Technology*; Rogers, K. R., Mulchandani, A., Zhou, W., Eds.; ACS Symposium Series 613; American Chemical Society: Washington, D.C., 1995; Ch. 5.
28. Bünzli, J.-C. G. In *Lanthanide Probes in Life, Chemical and Earth Sciences*; Bünzli, J.-C. G.; Choppin, G. R., Eds., Elsevier: Amsterdam, 1988; Ch. 7, p. 219.
29. (a) Balzani, V.; Scandola, F. *Supramolecular Photochemistry*; Ellis Horwood: West Sussex, England, 1991. (b) Balzani, V. *Pure Appl. Chem.* **1990**, *62*, 1099.
30. (a) Lehn, J.-M. *Angew. Chem., Int. Ed. Engl.* **1988**, *27*, 89. (b) Lehn, J.-M. *J. Incl. Phenom. Mol. Recog.* **1988**, *6*, 351.

31. Horrocks, W. DeW., Jr.; Albin, M. In *Progress Inorganic Chemistry*; Lippard, S. J., Ed., John Wiley & Sons: New York, 1983; Vol. 31, p. 1.
32. Pikramenou, Z.; Nocera, D. G. *Inorg. Chem.* **1992**, *31*, 532.
33. Pikramenou, Z.; Nocera, D. G. *Tetrahedron Lett.* **1993**, *34*, 3531.
34. Mortellaro, M. A.; Nocera, D. G. *J. Am. Chem. Soc.* **1996**, *118*, 7414.
35. Ponce, A.; Wong, P. A.; Way, J. J.; Nocera, D. G. *J. Phys. Chem.* **1993**, *97*, 11137.
36. Mortellaro, M. A.; Hartmann, W. K.; Nocera, D. G. *Angew. Chem., Int. Ed. Engl.* **1996**, *35*, 1945.
37. (a) Berberan-Santos, M. N.; Canceill, J.; Brochon, J.-C.; Jullien, L.; Lehn, J.-M.; Pouget, J.; Tauc, P.; Valeur, B. *J. Am. Chem. Soc.* **1992**, *114*, 6427. (b) Ueno, A.; Suzuki, I.; Osa, T. *ibid*, **1989**, *111*, 6391.
38. (a) Breslow, R.; Czarnik, A. W. *J. Am. Chem. Soc.* **1983**, *105*, 1390. (b) Breslow, R. Hammond, M. Lauer, M. *ibid*. **1980**, *102*, 421.
39. Martin, K. A.; Mortellaro, M. A.; Sweger, R. W.; Fikes, L. E.; Winn, D. T.; Clary, S. C.; Johnson, M. P.; Czarnik, A. W. *J. Am. Chem. Soc.* **1995**, *117*, 10443.
40. (a) Rao, K. R.; Srinivasan, T. N.; Bhanumathi, N.; Sathur, P. B. *J. Chem. Soc., Chem. Commun.* **1990**, *10*. (b) Cramer, F.; Mackensen, G. *Angew. Chem., Int. Ed. Engl.* **1966**, *5*, 601.
41. Koochesfahani M. M.; Nocera, D. G. *Exp. in Fluids*, **1997**, in press.
42. Adrian, R. J. *Ann. Rev. Fluid Mech.* **1991**, *23*, 261.
43. Hartmann, W. K.; Gray, M. H. B.; Ponce, A.; Nocera, D. G.; Wong, P. A. *Inorg. Chim. Acta* **1996**, *243*, 239.
44. Gendrich, C. P.; Koochesfahani, M. M.; Nocera, D. G. *Exp. in Fluids* **1997**, in press.
45. Gendrich, C. P.; Koochesfahani, M. M.; Nocera, D. G. *Bull. Am. Phys. Soc.* **1994**, *39*, 1980. (b) Koochesfahani, M. M.; Cohn, R. K.; Gendrich, C. P.; Nocera, D. G. *Developments in Laser Techniques in Fluid Mechanics*; Springer-Verlag: Berlin, 1997, in press.

4. Personnel

The synthesis and fast laser spectroscopy that is at the core of this research program is emphasized by the graduate student and postdoctoral support. *Drs. Mark Mortellaro and Jude Rademacher* were postdoctoral research associates who coordinated the synthetic effort. They obtained their Ph.D.s in organic synthetic chemistry from Ohio State University under the direction of Professor Anthony Czarnick. Both were experts in the synthetic chemistry of CDs and they have published extensively in the field. *James P. Kirby* was a organic chemistry Ph.D. candidate who contributed to various aspects of the synthesis when the extra effort was demanded. His work laid the foundation for many of the active sites developed during the program cycle. The picosecond time-resolved measurements on the various active sites was performed by graduate student *James A. Roberts* and *Wanda Hartmann* performed all the steady-state electronic absorption spectroscopy and time-resolved nanosecond measurements for our active sites

5. Publications

“Luminescence from Supramolecules Triggered by the Molecular Recognition of Substrates”; Zoe Pikramenou, Jeong-a Yu, Ronald B. Lessard, Adrian Ponce, Peter A. Wong, and Daniel G. Nocera, *Coord. Chem. Rev.* **1994**, *132*, 181.

“Analysis of Molecular Tagging Velocimetry Images for Obtaining Simultaneous Multipoint Velocity Vectors”; Charles P. Gendrich, Manooch M. Koochesfahani and Daniel G. Nocera, *Bull. Am. Phys. Soc.* **1994**, *39*, 1980.

“Molecular Tagging Velocimetry in Gas Phase Flow”; Bernd Stier, Manoochehr M. Koochesfahani, Daniel G. Nocera and Harold J. Schock, *Bull. Am. Phys. Soc.* **1995**, *40*, 2000.

“Substrate Induced Phosphorescence from Cyclodextrin • Lumophore Host-Guest Complexes”. Wanda K. Hartmann, Mike H. B. Gray, Adrian Ponce and Daniel G. Nocera, *Inorg. Chim. Acta* (Harry B. Gray issue) **1996**, *243*, 239.

“Efficient Singlet Oxygen Generation from Polymer Derivatized with Hexanuclear Molybdenum Clusters”; Julie A. Jackson, Mark D. Newsham. Celeste Worsham and Daniel G. Nocera, *Chem. Mater.* **1996**, *8*, 558.

“Exciplex Fluorescence Visualization Systems for Pre-Combustion Diagnosis of an Automotive Gasoline Engine”; JongUk Kim, Harold J. Schock, Daniel G. Nocera, Brage Golding and Phillip Keller, *Adv. Eng. Comb. Flow Diag.* **1996**, *SAE960826*, 295.

“Not Just Another Pretty Shape”; Daniel G. Nocera, *New Scientist* **1996**, *149* (13 January 1996), 24.

“A Turn-on for Optical Sensing”; Mark A. Mortellaro and Daniel G. Nocera, *ChemTech* **1996**, *26*, 17.

“Regioisomeric Control of the Excited State Processes of a Cyclodextrin Modified with a Lumophore”; Mark A. Mortellaro, Wanda K. Hartmann and Daniel G. Nocera, *Angew. Chem., Int. Ed. Engl.* **1996**, *35*, 1945.

"A Supramolecular Chemosensor for Aromatic Hydrocarbons"; Mark A. Mortellaro, and Daniel G. Nocera, *J. Am. Chem. Soc.* **1996**, *118*, 7414.

"Exciplex Fluorescence Visualization Systems for Two Phase Visualization"; JongUk Kim, John Darrow, Harold J. Schock, Daniel G. Nocera, Brage Golding and Phillip Keller"; *Bull. Am. Phys. Soc.* **1996**, *41*, 380.

"Velocity Measurements in a Steady Flow Model of an IC Model using Molecular Tagging Velocimetry"; Bernd Stier, Manoochehr M. Koochesfahani, Daniel G. Nocera and Harold J. Schock, *Bull. Am. Phys. Soc.* **1996**, *41*, 1804.

"New Exciplex Fluorescence Systems for Vapor-Liquid Visualization"; JongUk Kim, John Darrow, Harold J. Schock, Daniel G. Nocera and Brage Golding *Bull. Am. Phys. Soc.* **1997**, *42*, in press.

"Molecular Tagging Diagnostics for the Study of Kinematics and Mixing in Liquid Phase Flows"; Manoochehr M. Koochesfahani, Richard K. Cohn, Charles P. Gendrich and Daniel G. Nocera, *Developments in Laser Techniques in Fluid Mechanics*, Springer-Verlag: Berlin, 1997, in press.

"Chemosensing of Monocyclic and Bicyclic Aromatic Hydrocarbons by Supramolecular Active Sites"; Wanda K. Hartmann, Mark A. Mortellaro, Zoe Pikramenou and Daniel G. Nocera, *Chemosensors of Ion and Molecule Recognition*; NATO ASI Series, Series C: Vol. 492; Desvergne, J.-P.; Czarnik, A. W., Eds; Kluwer Academic; Dordrecht, 1997; p. 159.

"The Electron Donor-Acceptor Exciplex of N,N-Dimethylaniline and 1,4,6-Trimethylnaphthalene"; JongUk Kim, Wanda Hartmann, Brage Golding, Harold J. Schock and Daniel G. Nocera, *Chem. Phys. Lett.* **1997**, *267*, 323.

"Molecular Tagging Velocimetry and other Novel Applications of a New Phosphorescent Supramolecule"; Charles P. Gendrich, Manoochehr M. Koochesfahani and Daniel G. Nocera, *Exp. Fluids* **1997**, *23*(5), 361-372.

"Lanthanide-Ion Modified Cyclodextrin Supramolecules"; Christina M. Rudzinski, Wanda K. Hartmann and Daniel G. Nocera, *Coord. Chem. Rev.* **1997**, in press.

"Energy Transfer Process for the Triggered Luminescence Response of a Lanthanide-Ion Modified Cyclodextrin Supramolecule toward Aromatic Hydrocarbons"; Christina M. Rudzinski, Wanda K. Hartmann and Daniel G. Nocera, *J. Phys. Chem.*, submitted for publication.

"Molecular Tagging Velocimetry: A Review of Techniques, Chemical Concepts, and Applications"; Manoochehr M. Koochesfahani and Daniel G. Nocera, *Exp. in Fluids*, **1997**, invited paper.