



NAVAL FACILITIES ENGINEERING SERVICE CENTER
Port Hueneme, California 93043-4370

Technical Memorandum TM-2275-AMP

TEST REPORT ON AN ANCHOR FITTING FOR ISO-TYPE CORNER CASTINGS

by

William G. Hatch

December 1997

Sponsored by
Chief of Naval Operations
Washington, DC 20350

19980408 000

DTIC QUALITY ESTABLISHED 3

Approved for public release; distribution is unlimited.

REPORT DOCUMENTATION PAGE			Form Approved OMB No. 0704-018	
Public reporting burden for this collection of information is estimated to average 1 hour per response, including the time for reviewing instructions, searching existing data sources, gathering and maintaining the data needed, and completing and reviewing the collection of information. Send comments regarding this burden estimate or any other aspect of this collection information, including suggestions for reducing this burden, to Washington Headquarters Services, Directorate for Information and Reports, 1215 Jefferson Davis Highway, Suite 1204, Arlington, VA 22202-4302, and to the Office of Management and Budget, Paperwork Reduction Project (0704-0188), Washington, DC 20503.				
1. AGENCY USE ONLY (Leave blank)		2. REPORT DATE December 1997		3. REPORT TYPE AND DATES COVERED Final; FY97
4. TITLE AND SUBTITLE TEST REPORT ON AN ANCHOR FITTING FOR ISO-TYPE CORNER CASTINGS			5. FUNDING NUMBERS	
6. AUTHOR(S) William G. Hatch				
7. PERFORMING ORGANIZATION NAME(S) AND ADDRESS(ES) Naval Facilities Engineering Service Center 1100 23rd Ave. Port Hueneme, CA 93043-4370			8. PERFORMING ORGANIZATION REPORT NUMBER TM-2275-AMP	
9. SPONSORING/MONITORING AGENCY NAME(S) AND ADDRESSES Chief of Naval Operations Washington, DC 20350			10. SPONSORING/MONITORING AGENCY REPORT NUMBER	
11. SUPPLEMENTARY NOTES				
12a. DISTRIBUTION/AVAILABILITY STATEMENT Approved for public release; distribution is unlimited.			12b. DISTRIBUTION CODE	
13. ABSTRACT (Maximum 200 words) This report addresses the development of a removable anchor that can be inserted into an ISO corner casting to convert it to a load-certifiable attachment point. This development was undertaken as part of a design for sea state 3 lighter connectors, specifically for the marriage bridle rigging. The ISO anchor was developed in consideration of the following characteristics: minimum ultimate strength of 90,000 pounds and a safe working load (SWL) of 15,000 pounds with a safety factor of 6; load to be applied along the deck in shear and at various radial angles relative to the ISO corner casting; installable in less than 5 minutes by one person using only hand tools. A concept resulted in a threaded insert that has the potential of being used for hoist ring attachments as well as any equipment or operation that requires a robust, quickly installed anchor point. This report describes the concept evolution through three prototype stages, documenting the load testing, fit and function of each variation. The final design is being incorporated into the deck rigging parts list for the sea state 3 connector Logistics Engineering Advanced Demonstration.				
14. SUBJECT TERMS Anchor point, ISO corner casting, marriage bridle, padeye, swivel hoist ring, hard point			15. NUMBER OF PAGES 28	
			16. PRICE CODE	
17. SECURITY CLASSIFICATION OF REPORT Unclassified	18. SECURITY CLASSIFICATION OF THIS PAGE Unclassified	19. SECURITY CLASSIFICATION OF ABSTRACT Unclassified	UL	

EXECUTIVE SUMMARY

The next generation of International Standardization Organization (ISO) compatible modular pontoon lighterage is designed to be sea state 3 capable during all phases of operation, including launching and at-sea connections. The design of the Amphibious Cargo Beaching (ACB) Lighter system identified the need for a field-installed padeye capable of being certified to a 15,000-pound safe working load (SWL) at a safety factor of 6. This report describes the development of a fixture that installs in an ISO corner fitting and accepts a commercially available swivel hoist ring, yielding a certifiable hard point with a rating of 20,000 pounds at a 6:1 SWL.

The design was based on the requirements for the marriage bridle system used to connect the pontoon modules at sea. A concept evolved from a wooden prototype through three steel versions, resulting in a threaded insert that has the potential of being used for hoist ring attachments as well as any equipment or operation that requires a robust, quickly installed anchor point.

The final design is referred to as an ISO anchor and is recommended for use with the marriage bridle system. Naval Facilities Engineering Service Center (NFESC) drawing 97050001 is the result of this investigation.

CONTENTS

	Page
INTRODUCTION.....	1
BACKGROUND	1
DESIGN PARAMETERS	1
APPROACH	2
SAFETY FACTORS	2
CONCEPT	3
PROTOTYPE MODEL A	4
Test A-1	4
Inspection	4
PROTOTYPE MODEL B	5
Test B-1	5
Inspection	5
Test B-2	6
Inspection	6
CONCLUSIONS	6
RECOMMENDATIONS	7

INTRODUCTION

The Naval Facilities Engineering Service Center (NFESC) has been tasked by the Office of Naval Research (ONR) under the Logistics Engineering Advanced Demonstration (LEAD) program to demonstrate the technologies required for an open-sea connection system for the next generation of sea state 3 (SS3) causeway lighterage. The demonstration of rigid and flexible connection systems is currently planned for Fiscal Year (FY) 1998.

A viable SS3-capable advanced causeway system, the Amphibious Cargo Beaching (ACB) Lighter system consists of pontoons that are joined by connectors to form barges and operational platforms. The connectors are joined at sea with variations of a wire rope marriage bridle system (Figure 1) that aligns the pontoons during the connection process, draws them together, and holds them in a mated configuration while the connectors are secured. In order to operate the marriage bridle system as safely as possible, it is necessary to use attachment points that can be load-rated while maintaining the low profile required for shipping and handling. The design and construction of these pontoons has followed the International Standardization Organization (ISO) specifications for ISO-configured cargo containers in order to facilitate shipping and handling. Specifically, steel receptacles known as ISO corner castings are an integral part of the deck surfaces and are designed as lifting and handling points. This report addresses the development of a removable anchor that can be inserted into a corner casting to convert it to a load-certifiable attachment point for marriage bridle rigging.

BACKGROUND

The marriage bridle consists of a pair of wire ropes running from the drum of the winch through snatch blocks, guides, and fairleads. When it is necessary for the wires to change direction, a wire rope snatch block is used as a turning point. After consideration of the desired bridle geometry and resultant locations for the turning point attachments, a decision was made to utilize the convenient ISO-type castings that are an integral part of the pontoon deck (Figure 2). The attachment of the snatch block to the ISO casting required a transitional hard point that had a variable direction of pull, could be readily installed or removed, was able to be certified to withstand the anticipated loads with an appropriate factor of safety, and was as cost efficient as possible. Surveys of commercially available container-handling and ISO-compatible fixtures yielded only fittings that were either made to pull in only one direction, were too weak for the applied loads, or were otherwise unsuited for the desired application. This void in commercially available hardware dictated the development of a new anchor point.

DESIGN PARAMETERS

The ISO anchor was developed in consideration of the following characteristics:

- Minimum ultimate strength of 90,000 pounds – resulting in a Safe Working Load

(SWL) of 15,000 pounds with a safety factor of 6. A higher SWL was desirable, if possible.

- Load to be applied horizontally – that is, along the deck in shear rather than vertically as in a lifting condition.
- Load may be applied at a small upward angle of 10 degrees or less.
- Load may be from various radial angles relative to the ISO corner casting.
- Installable in less than 5 minutes time by one person with hand tools. No welding required. Bolting is O.K.
- Anchor must be reusable.
- Must be able to be stowed easily.

APPROACH

A review of the design and load ratings of the corner castings and connecting hardware revealed that the rated capacity of the existing hardware was in consideration of an installation in a standard cargo container. Although the structure of the corner casting is adequate for the intended loads in this new application, the construction of a typical cargo container does not permit the development of loads that are capable with a pontoon deck of 3/8-inch steel plate.

The construction of the corner casting lends itself well to the implementation of a toggle bar or plate that can be inserted in the long axis of the top access hole and then be rotated 90 degrees to lock in place (Figure 3). This method works well when lifting, especially with a frame or mechanism to prevent the toggle bar from rotating back to the install/remove position. If the load is applied normal to the lifting axis, the amount of clearance required for installation results in a loose fit that could cause unpredictable loads in a rigid one piece toggle bar. Loads applied radially about the vertical axis could also result in rotation and detachment of the toggle bar.

The survey for commercial alternatives was expanded throughout the lifting, rigging, and materials handling industries, and a promising option was found in the swivel hoist ring (SHR). Several competing commercial firms offer the SHR as a line item and seem to adhere to the same general design (Figure 4). The rings are capable of swiveling under load to provide optimum alignment of the bail. This rotation covers 360 degrees in the horizontal plane and 180 degrees through the vertical plane. Attachment is through a single high strength bolt that ranges in size and capacity well beyond the design criteria for the subject anchor. Industry standards indicated that a bolt size of 1-1/2 inches should yield a satisfactory margin of safety. The installation of the SHR bolt into a toggle plate held promise as a solution, and further analysis on the 1-1/2-inch size was conducted.

SAFETY FACTORS

The 1-1/2-inch diameter SHR typically yields a safe working load of 24,000 pounds based on a factor of safety of 5 from the ultimate. The safety factor for hard points on the ACB lighter and connector system is 6, which translates to a SWL of 20,000 pounds for the 1-1/2-inch SHR. Although this margin of safety may seem excessive for some of the structural

components, it is a reasonable factor for padeyes that are primarily used for block attachments. Although the design geometry of the marriage bridles results in padeye reactions that are greater than the applied line load, they are increased by no more than 20 to 25 percent, with acceptable stresses applied to the padeye. Operationally, it is conceivable that a situation may arise when it is desired to run a winch wire from the drum through the block and back toward the winch. Under this scenario, it is possible to double the effective line pull (as seen at the padeye), cutting the safety factor to 3. The application for the padeye and anchor point is defined as part of a towing arrangement, and specifications for such a fixture are identified in a Naval Sea Systems Command (NAVSEA) specification. Section 582c of S9AAO-AB-GOS-010 (General Specification for Overhaul of Surface Ships) cites a required safety factor of 3 for the pad of towing arrangements (new systems). Design working loads for the marriage bridle system are 15,000 pounds, or a minimum ultimate design load of 90,000 pounds. Ideally, it was desired to provide an anchor that could withstand the ultimate capacity of the SHR (120,000 pounds) and provide a serviceable attachment that was rated at 20,000 pounds with a 6:1 safety factor.

CONCEPT

When threaded into a toggled bar inside the corner casting, the SHR would provide the required capacity if the load was applied vertically. When the loads were applied laterally, however, some negative effects resulted. A bending moment results from the 1-inch gap between the base of the SHR and the top of the toggle plate when the load is applied horizontally (along the deck). Loads applied at various angles around the bolt can create an overturning moment as the pull comes in line with the short axis of the toggle plate. These conditions as well as a lack of assuring positive toggle bar alignment during installation dictated the addition of another piece to the assembly. This "U-shaped" piece, referred to as a locking ring and shown in Figure 3, would be placed over the toggle bar (capture bar) and fill the space between it and the base of the SHR. The locking ring would provide support for the shank of the bolt and would transfer lateral loads through the casting directly into the plate deck of the pontoon. Additional benefits would also be derived by assuring a proper 90-degree capture bar alignment and preventing overturning when the direction of pull was across the short axis of the capture bar. A wooden mock-up of the anchor was fabricated to verify the fit and give a visual indication of the installation and functional possibilities.

An analysis of the design working loads was favorable as it showed that the transfer from the SHR through the ISO casting and into the steel deck plate created low stresses in all components. When the loads approached the ultimate capacity of the SHR, the stresses in the anchor and the casting were still at acceptable levels. Further analysis of the concept was delayed until a working model could be fabricated and tested. The drawings were completed and a steel ISO anchor was ordered.

PROTOTYPE MODEL A

The first anchor model was machined from A-36 steel and the design did not create any unusual problems for the fabricator. The fit within the casting was loose to ensure ease of installation and the components fit and operated as expected.

A swivel hoist ring was obtained from Actek of Santa Fe Springs, California, and generally conformed to the previously observed SHR design (Figure 5). A bolt length of 3 inches below the base of the SHR was requested in order to provide adequate engagement of the toggle bar as well as to prevent the bolt from bottoming out on the inside of the casting. The bolt appeared to be a high strength cap screw that required a 1-inch hex socket wrench to tighten. A plate on the SHR indicated that the bolt needed to be tightened to 800 ft/lbs in order to achieve the rated capacity of 24,000 pounds SWL.

A test jig assembly that could operate in NFESC's 400,000-pound capacity universal testing machine was designed and fabricated from 2-inch thick steel plate.

Test A-1

The prototype anchor was installed in the test jig (Figure 6) and the swivel hoist ring was inserted through the locking ring to engage the threads of the capture bar (Figure 7). It should be noted that it is necessary to use a torque multiplier to reach the specified bolt pretension of 800 ft/lbs. The assembly was raised into the test machine and connected with 2-inch, 35-ton capacity shackles. The orientation of the test jig relative to the bail of the SHR created an upward pull of approximately 10 degrees (Figure 8). The offset, due to the design of the jig and the geometry of the 35-ton shackles, simulates the offset that is anticipated when the shackles and snatch blocks are rigged on the deck of the pontoons. The bulk of the connecting hardware attached to the bail precludes pulling at 90 degrees to the bolt axis.

The load was slowly increased to 40,000 pounds and held for 10 to 15 seconds to check for signs of creep or stretching. The load was slowly raised in increments of 10,000 pounds thereafter, with similar stops for signs of decreasing load. There were small signs of load relief at 60,000 pounds, which were attributable to stretch in the shackles, but there were no further signs until 90,000 pounds was reached. In the course of loading from 60K to 90K, the base of the SHR was observed to tilt, causing the edge furthest from the bail to raise above the surface of the casting (Figure 9). Because this load level was the initial goal for testing, and in consideration of the fact that additional creep was observed, the jig assembly was unloaded and removed for inspection.

Inspection

As the cap screw was removed from the fixture, it was apparent that it had been bent slightly (Figure 10). Impressions on the surface of the casting showed that the base of the SHR had "dug in" on the bail side and raised the base on the off side. This was attributed to the lack of support at the extreme edge of the base on the bail side of the SHR. An inspection of the locking ring piece of the anchor showed that the threads of the cap screw had been forced into the mild steel, leaving a deep impression (Figure 11). The capture bar showed slight impressed marks from the casting, but they were superficial in nature. Although the prototype anchor did

pass the first test goal of 15,000 pounds with a verified 6:1 safety factor, it was obvious that improvements could be made and that a goal of 20,000 pounds with a 6:1 safety factor should be attainable. These improvements were incorporated into the next prototype, Model B.

PROTOTYPE MODEL B

Results from the inspection of the first prototype indicated that decreasing the clearances on the fit of the locking ring could permit a higher load capacity. The bolt hole tolerance was decreased to permit a maximum clearance of 0.031 inch and the fit between the outer edge and the opening of the casting allows a maximum of 0.058 inch of free play. These tighter dimensions are intended to reduce bending of the bolt and rotation of the locking ring.

The observed uplift of the SHR base was due to a lack of support over the opening of the casting. When the diameter of the base is less than the length of the opening, and when the direction of pull is in line with the opening, the leading edge of the base tends to "fall into the hole." The best correction for this problem was incorporation of a thick (0.75 inch) washer plate between the SHR base and the casting. Although this does increase the length of the bolt between the head and the point of thread engagement, the support is intended to minimize or eliminate the bending due to uplift. The effect of raising the bail by 0.75 inch also aligns the pull closer to 90 degrees and applies more shear load to the bolt.

Two versions of the second prototype were scheduled for the next test: one model with an integral washer plate and modified tolerances on the locking ring (Figure 12), and another with a separate washer plate between the SHR base and a Model A locking ring/capture bar assembly (Figure 13). The locking ring with the integral washer plate was expected to be stronger structurally and more difficult to manufacture. A comparison to a loose washer was desired to see if the more economical approach could be as effective.

Test B-1

The model with the integral washer was tested first. Assembly was the same as before, except for the bolt. The original SHR bolt had been replaced with a standard Grade 8 hex-head bolt (Figure 14). After torquing the bolt to 800 ft/lbs, the jig assembly was raised into the machine. The loads were applied in the same manner as before, stopping for signs of creep at 10K intervals. The goal of 90,000 pounds was reached with no significant uplift observed at the SHR base. The assembly was unloaded and removed in order to inspect the components and compare the effects of 90K loading to those observed on the first model (Model A).

Inspection

The bolt was bent slightly (less than 2 degrees), but much less than the cap screw from Test A-1. The locking ring had thread impressions and marks from the surface of the casting, but these were not as deep as in Test A-1. There was no observable change in the capture bar.

Test B-2

The second assembly was installed in the jig with the loose washer plate between the base and the casting. With the bolt tightened and the jig raised into the test machine, the load was applied in the same manner as before. There was some slight creep noticed at the 80,000-pound level, but the assembly held firm at 90,000 pounds. The load was increased to 100,000 pounds and then to 110,000 pounds with a gradual increase in the amount of creep. A definite gap had appeared between the washer and the casting and the gap began increasing as the load passed 115,000 pounds. Failure occurred at 119,000 pounds.

Inspection

The failure occurred at the top of the first thread of the bolt (Figure 15), which was located between the top of the washer plate and the SHR base. The threads had also been impressed into the hole of the locking ring, and the washer plate showed marks from bearing and slipping on the surface of the casting (Figure 16). The rest of the assembly showed little or no effects from the test. Fabrication drawings for the ISO anchor to be used in the connector tests are shown as Figure 17. No further testing was done to evaluate the anchor.

CONCLUSIONS

The tests conducted in the universal test machine resulted in several conclusions regarding the performance and viability of the ISO anchor design:

1. It is possible to build an insert for an ISO corner casting that can withstand a horizontal loading of 120,000 pounds.
2. A commercial swivel hoist ring can connect to such an insert and provide a connection point for a load of 120,000 pounds. A bolt with a longer (unthreaded) shank should be specified when procuring the SHR. The shank should extend 1-1/4 inches to 1-1/2 inches below the base of the SHR. The threaded portion should be 2 inches long.
3. The SHR bolts should be inspected periodically and replaced as necessary.
4. The ISO anchor components may be machined from mild (A-36 or 1018) steel or common grade stainless steel.
5. The ISO anchor should be comprised of three pieces: the capture bar, the locking ring, and the loose washer plate.
6. The anchor must be installed with a torque wrench and a torque multiplier to ensure proper pretension in the connecting bolt.

7. The ISO anchor may be used with the swivel hoist ring to provide a certifiable attachment point for loads at any angle and from any direction, up to the SWL of the swivel hoist ring.

8. The anchor may be used as an attachment point for other gear or equipment, but should be load tested, as necessary, with the specific requirements for that gear. The washer plate may or may not be required to span the opening of the corner casting.

RECOMMENDATIONS

The ISO anchor should be used as the means of connecting the marriage bridle hardware to the available corner castings. The design drawing (Figure 17) resulting from these tests should be used for fabrication.

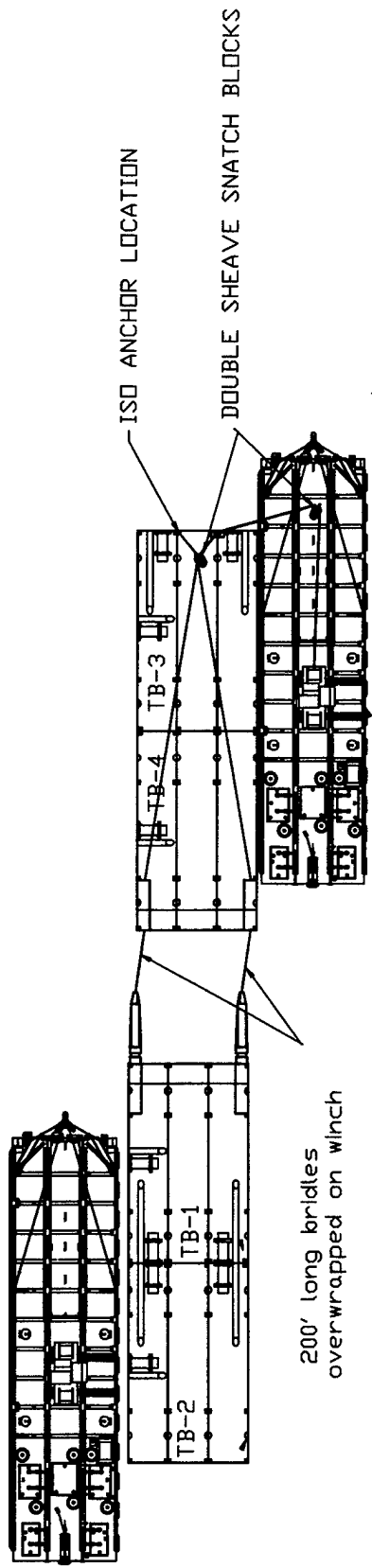

Figure 1. Marriage Bridle Rigging (NFESC # 9700164)

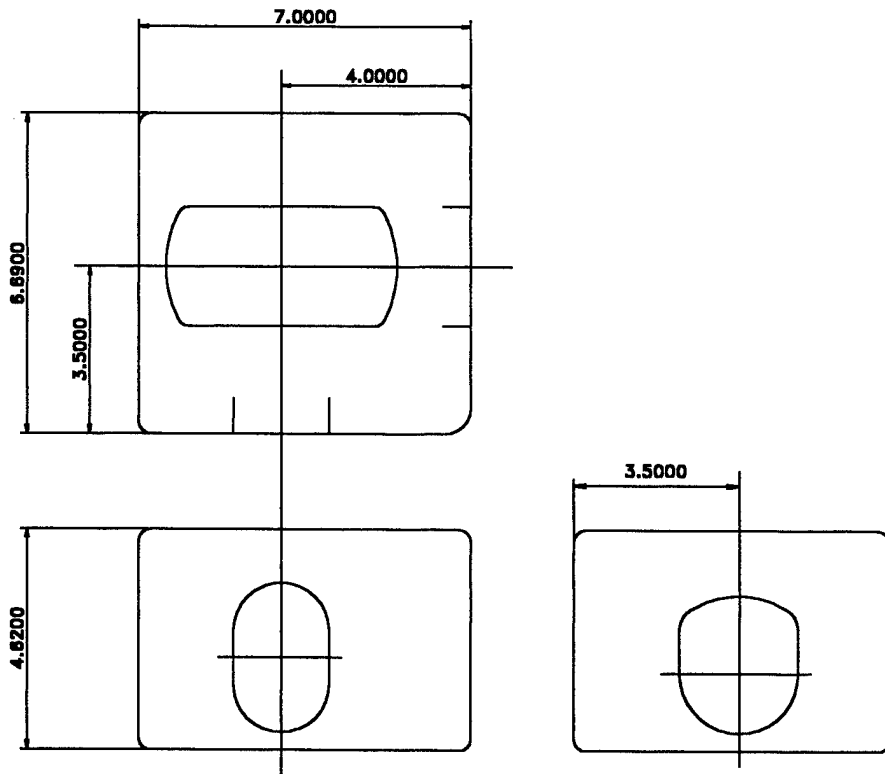
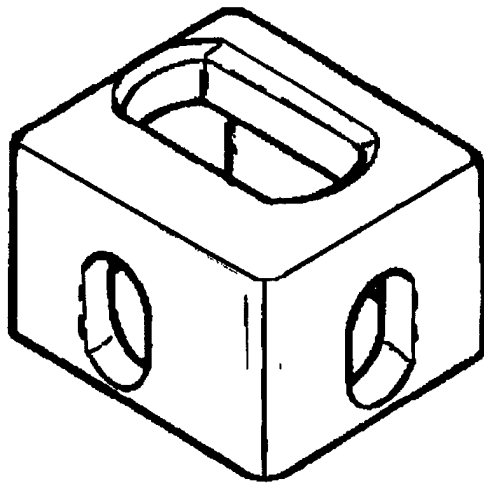

Figure 2. Typical ISO Corner Fitting (NFESC # 9700165)

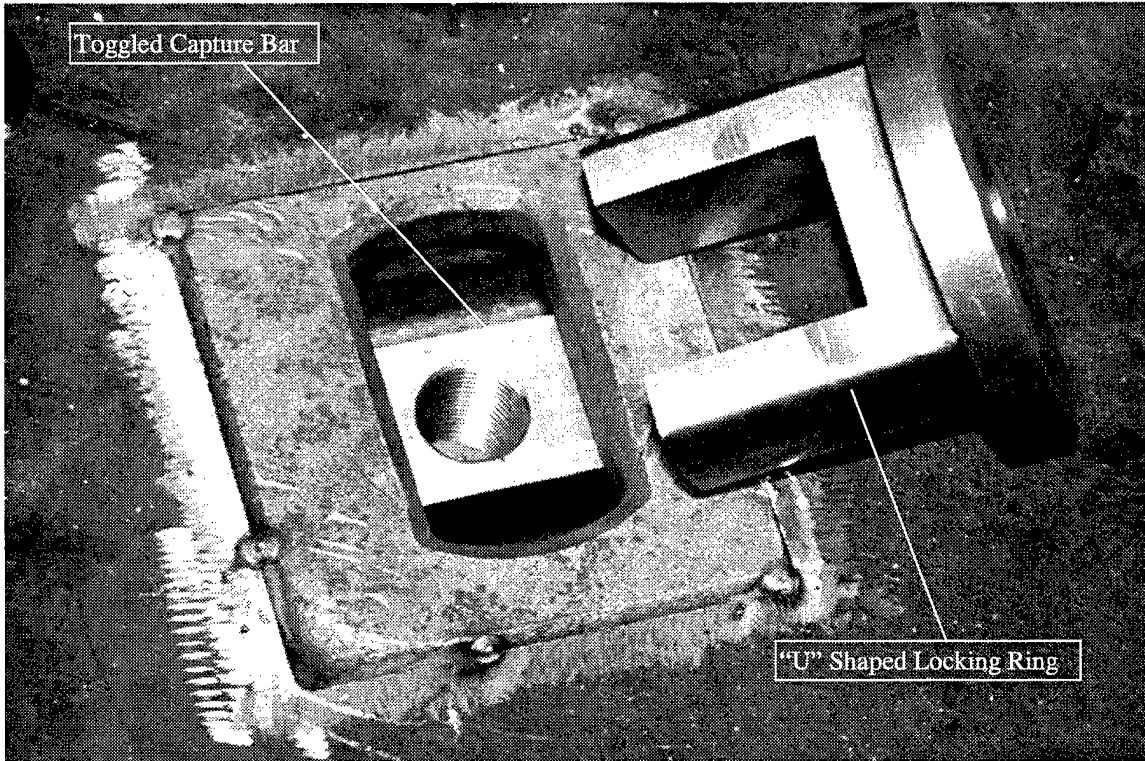

Figure 3. ISO Anchor Components (NFESC # 9700167)

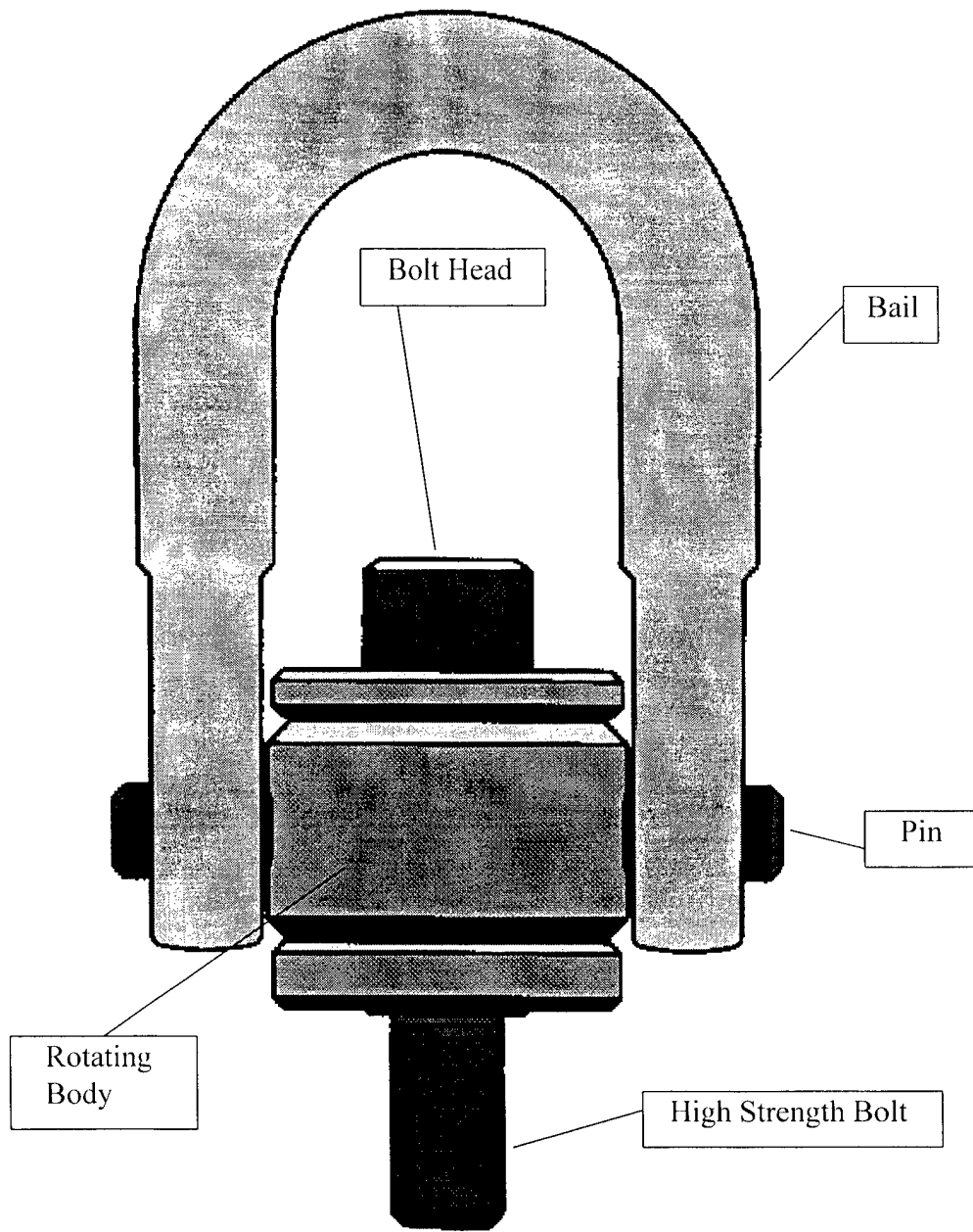

Figure 4. Typical Swivel Hoist Ring (NFESC # 9700168)

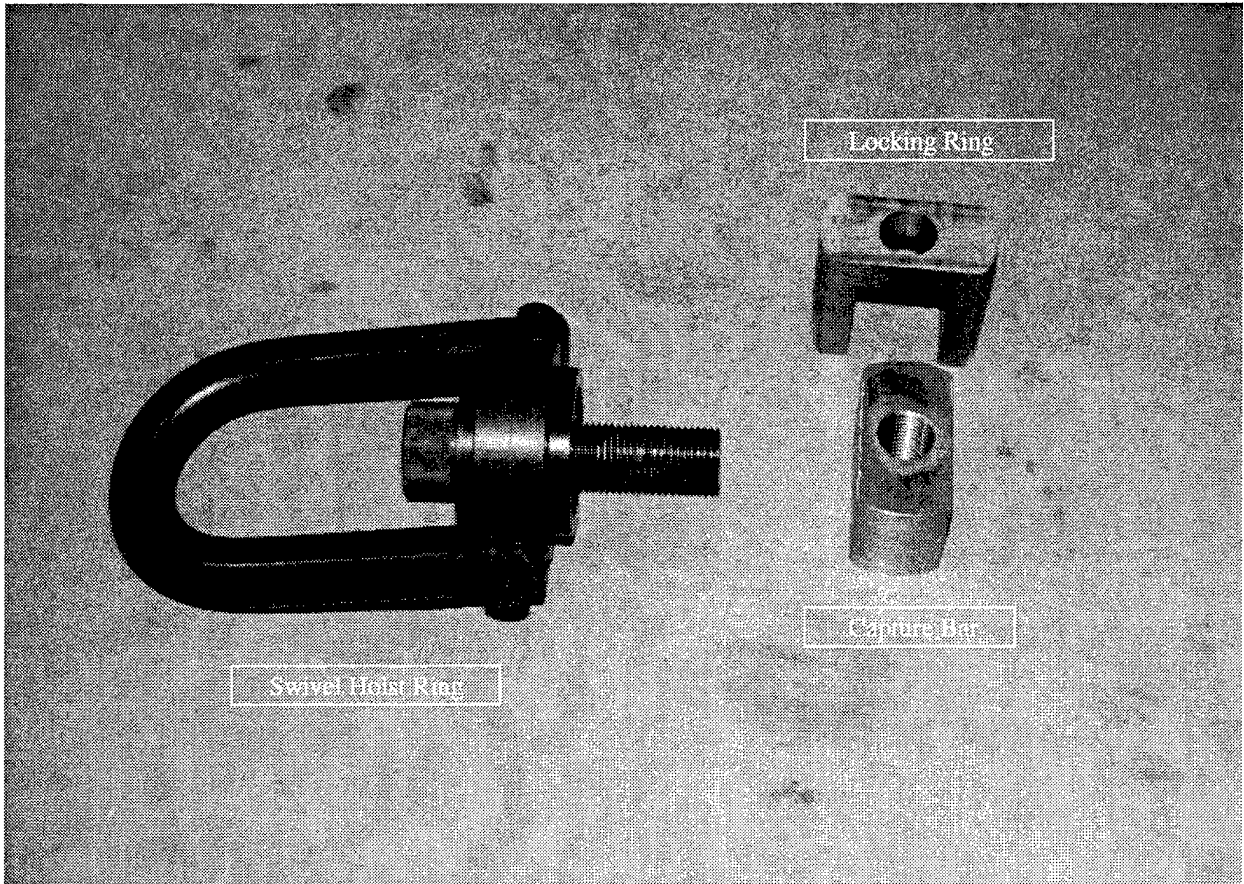

Figure 5. Swivel Hoist Ring with Anchor Components (NFESC # 9700125)

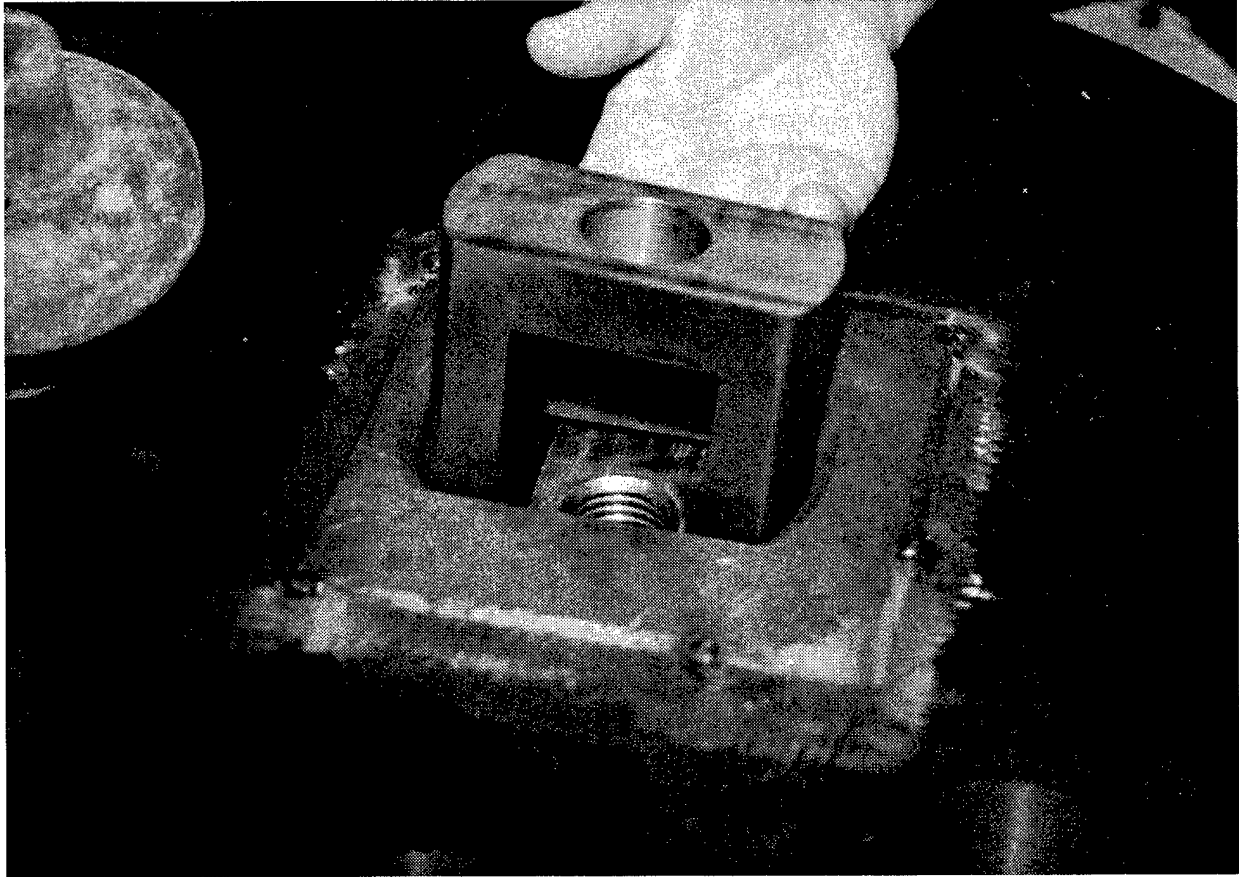

Figure 6. Anchor Components Being Installed in Test Jig (NFESC # 9700126)



Figure 7. SHR Being Installed in ISO Anchor (NFESC # 9700127)

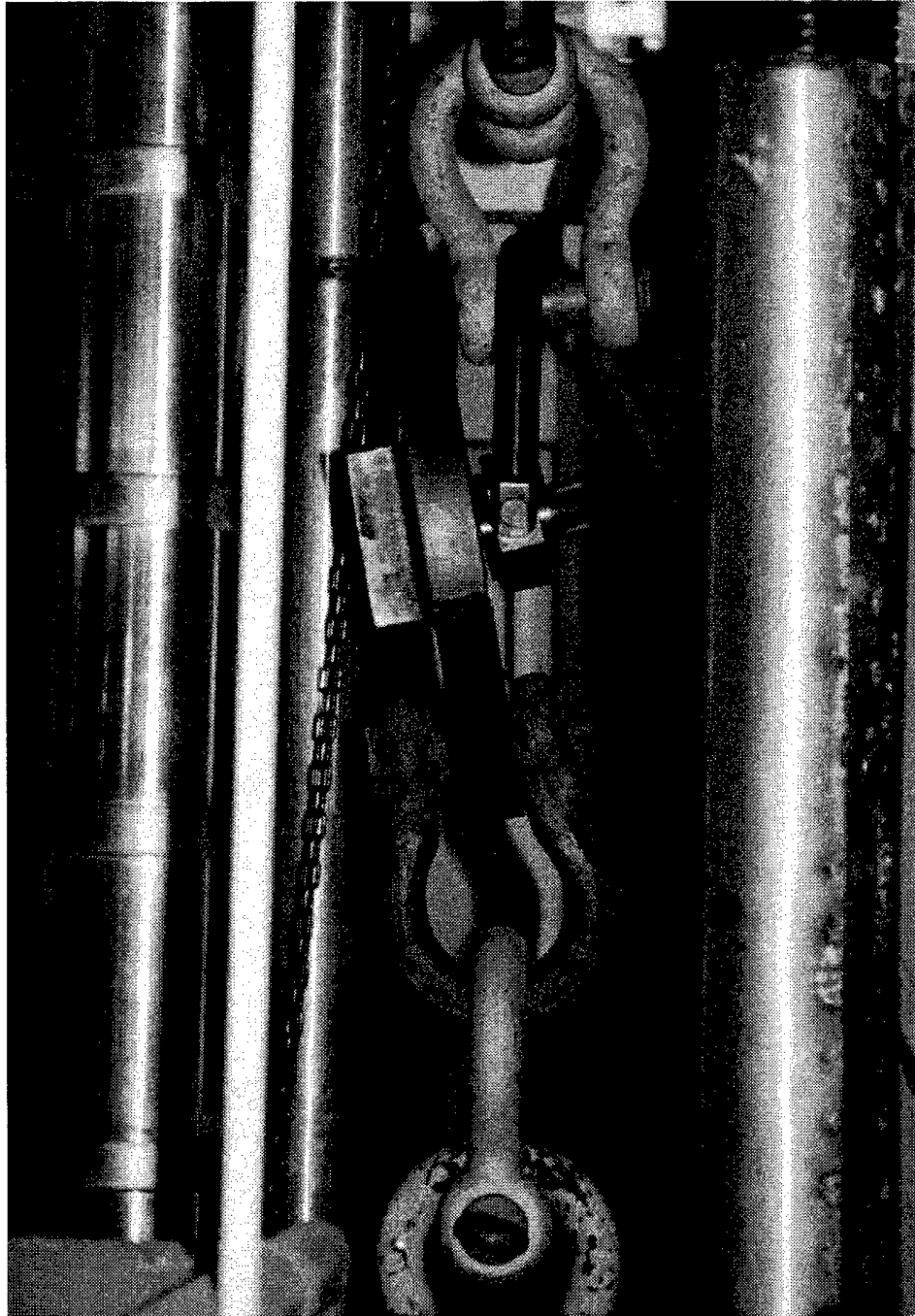

Figure 8. SHR Angle of Pull Simulates Barge Application (NFESC # 9700128)

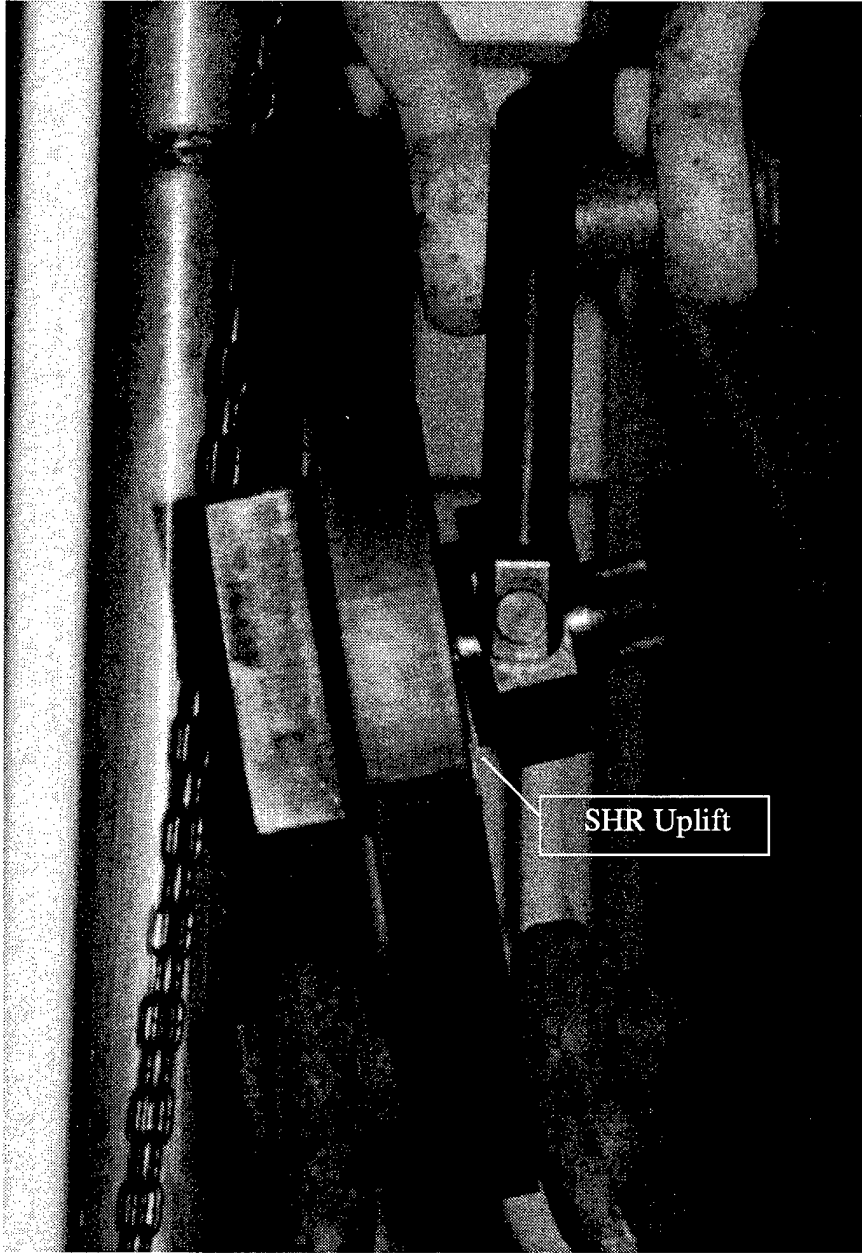

Figure 9. Base of Swivel Hoist Ring Tilts at 90,000 Pounds (NFESC # 9700128a)

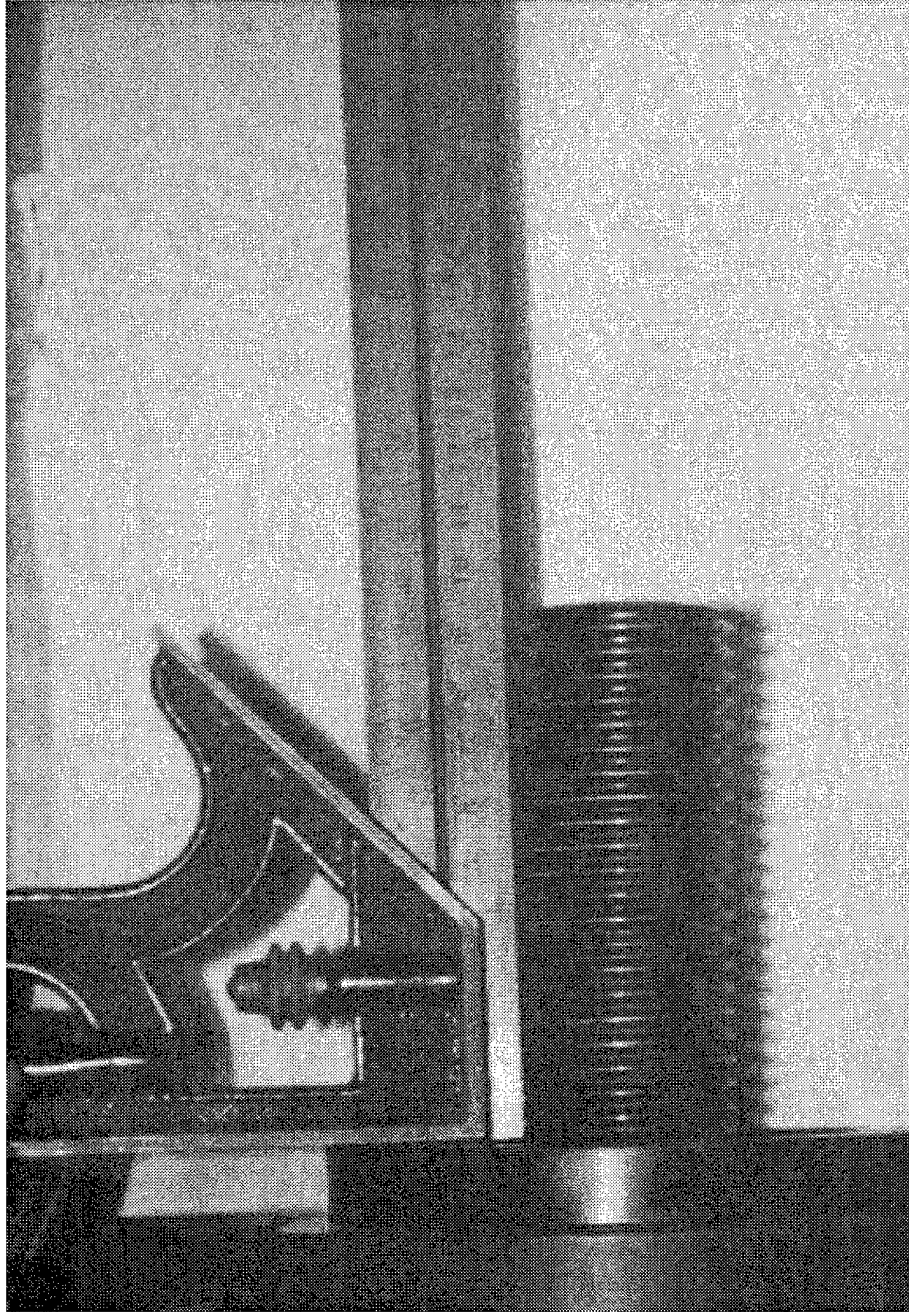

Figure 10. Bolt After 90,000-Pound Load Test (NFESC # 9700130)

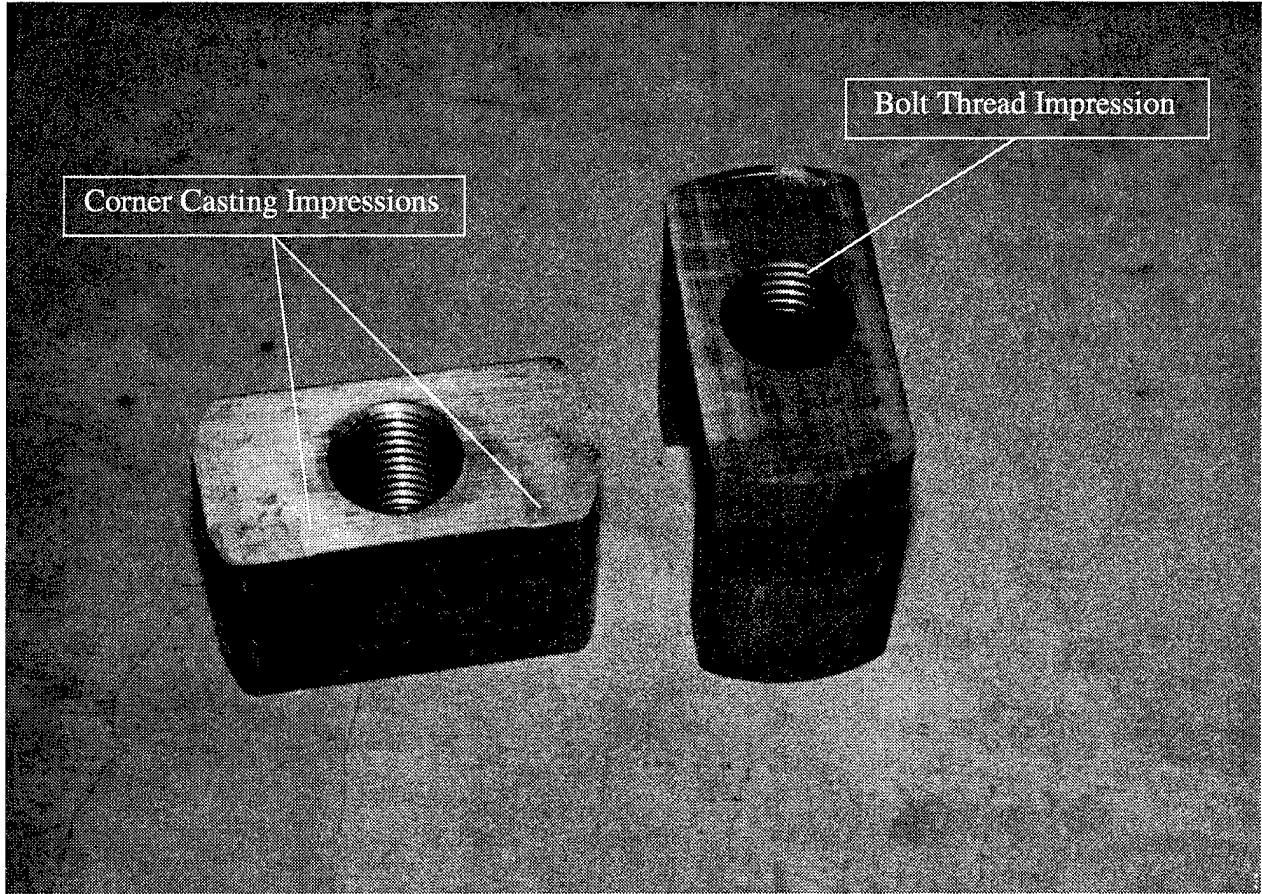

Figure 11. Capture Bar and Locking Ring After Load Test (NFESC # 9700129)

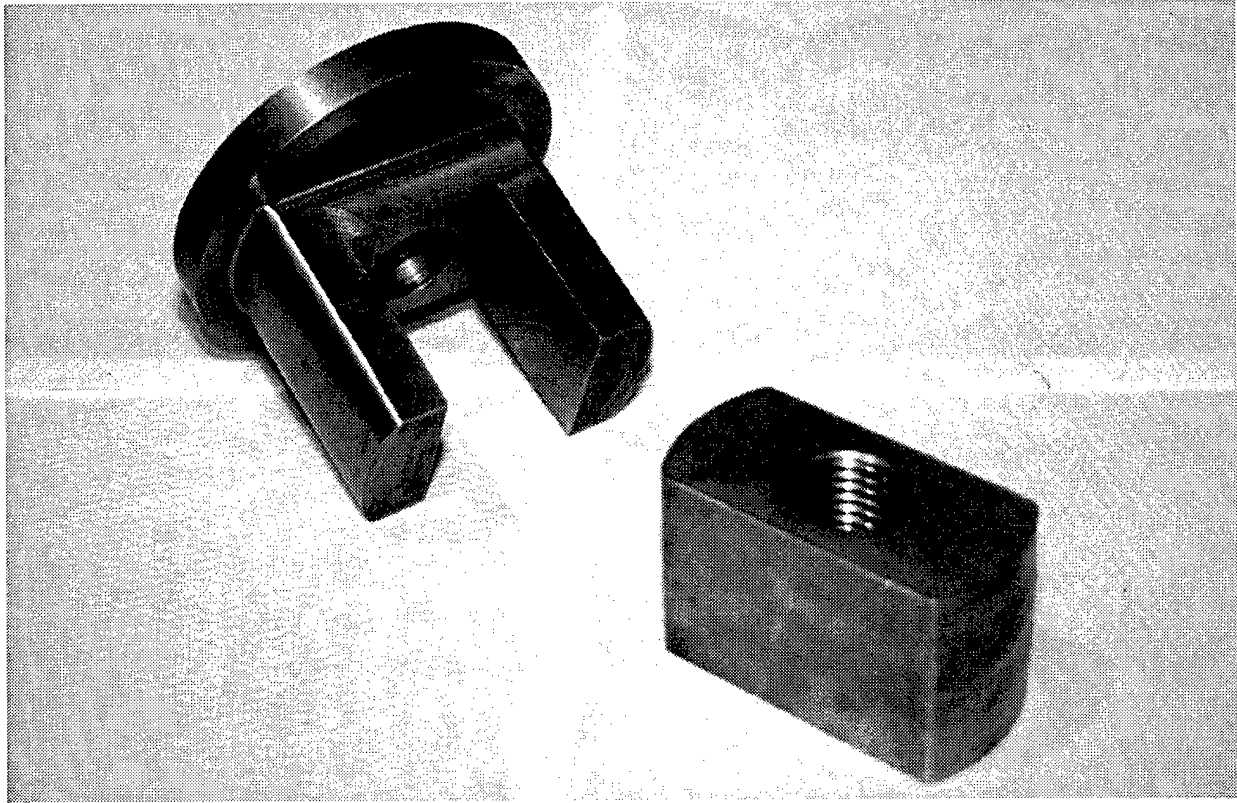

Figure 12. Second Generation Locking Ring with Integral Washer Plate (NFESC # 9700169)

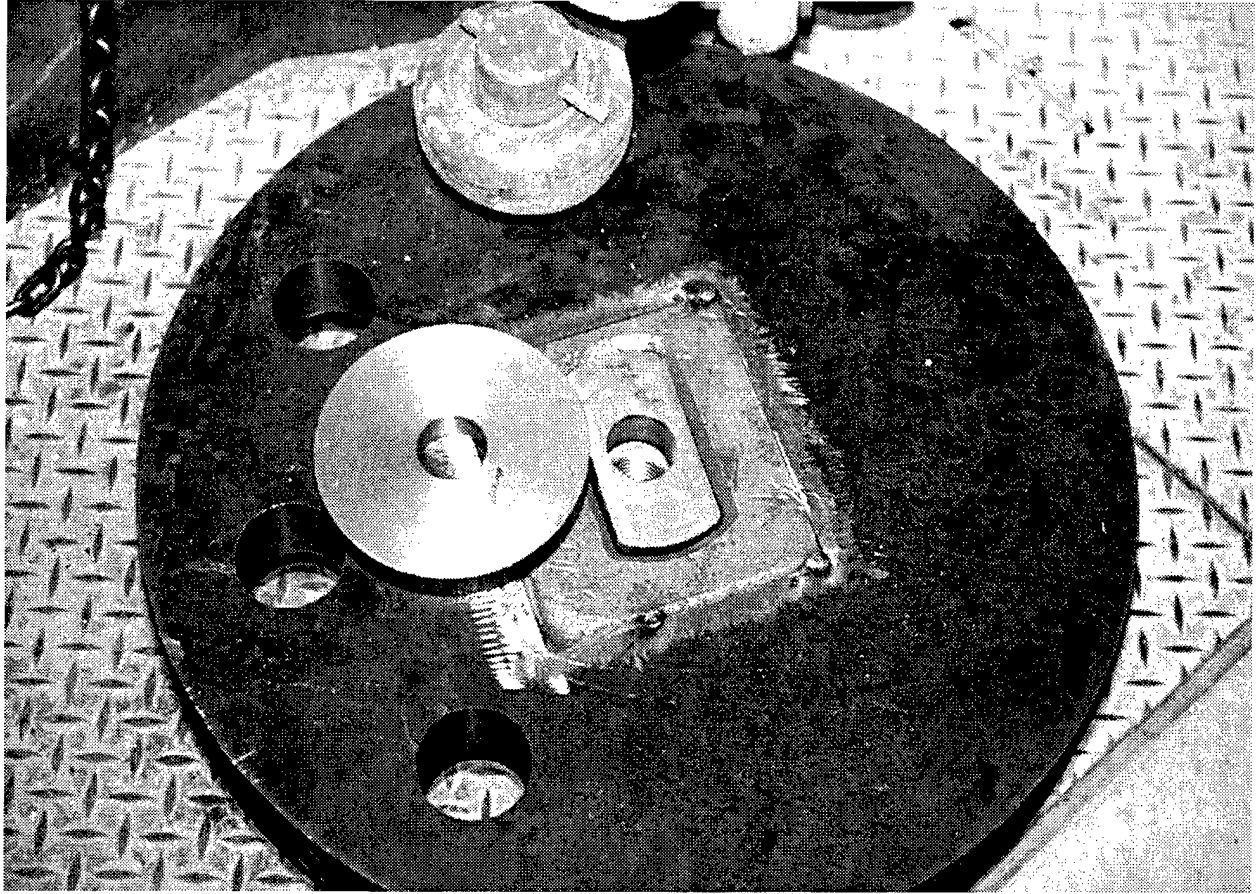

Figure 13. ISO Anchor in Test Jig with Loose Washer Plate (NFESC # 9700170)

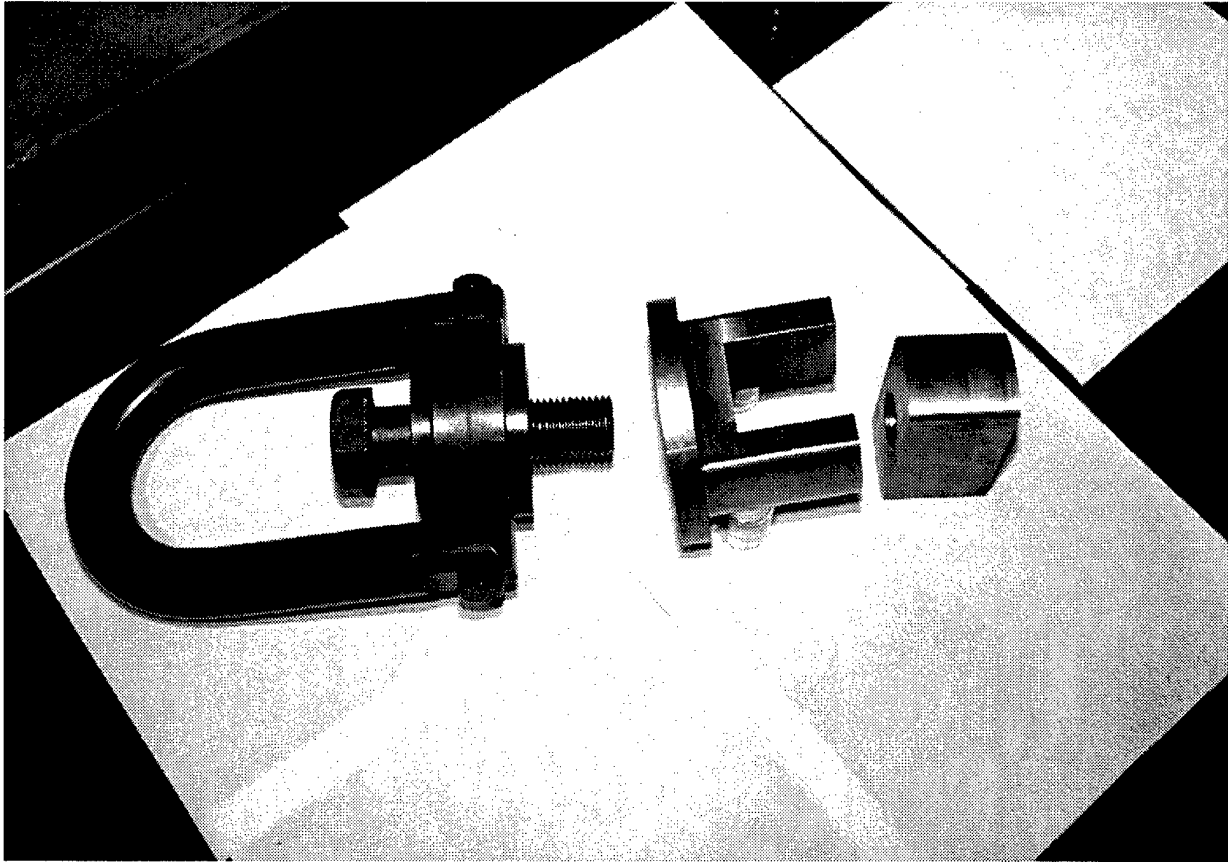

Figure 14. Locking Ring with Integral Washer Plate and Grade 8 Hex Bolt
(NFESC # 9700171)



Figure 15. Bolt Failure at 119,000 Pounds (NFESC # 9700172)

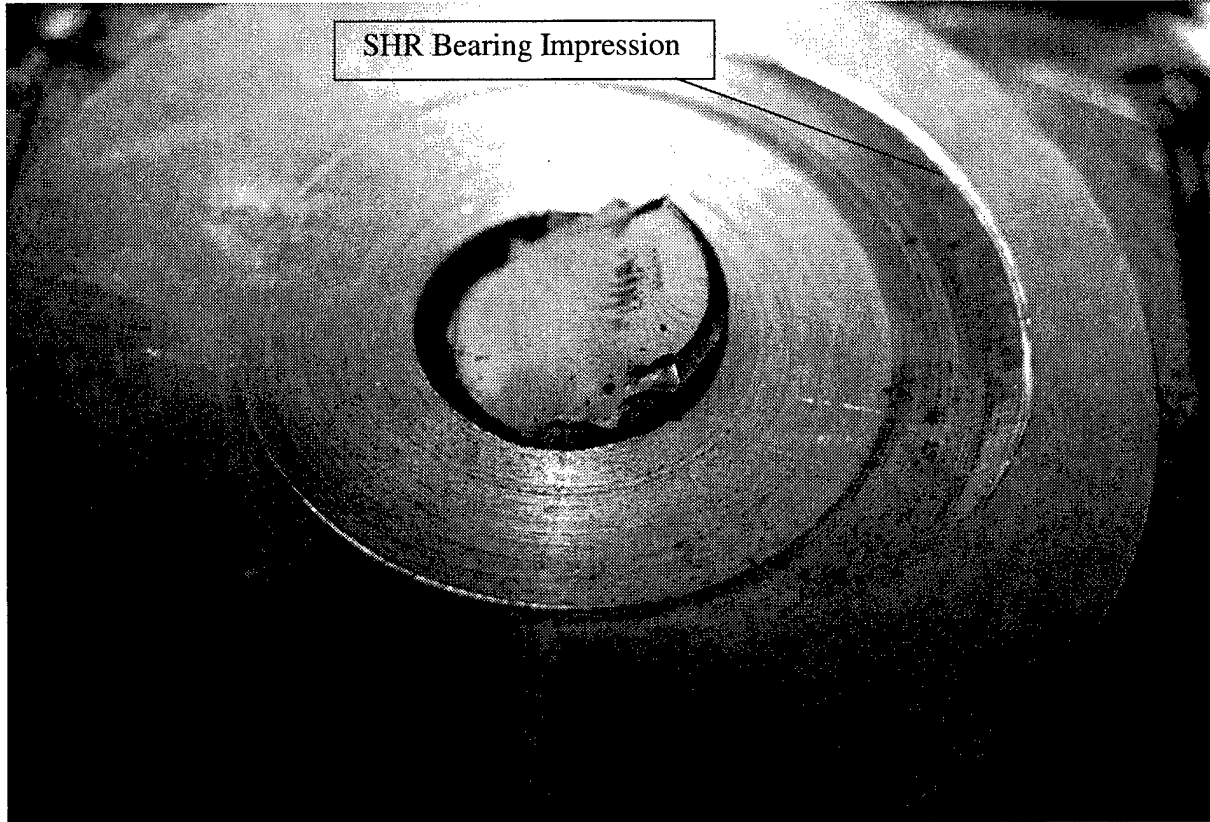

Figure 16. Washer Plate with Broken Bolt (NFESC # 9700173)

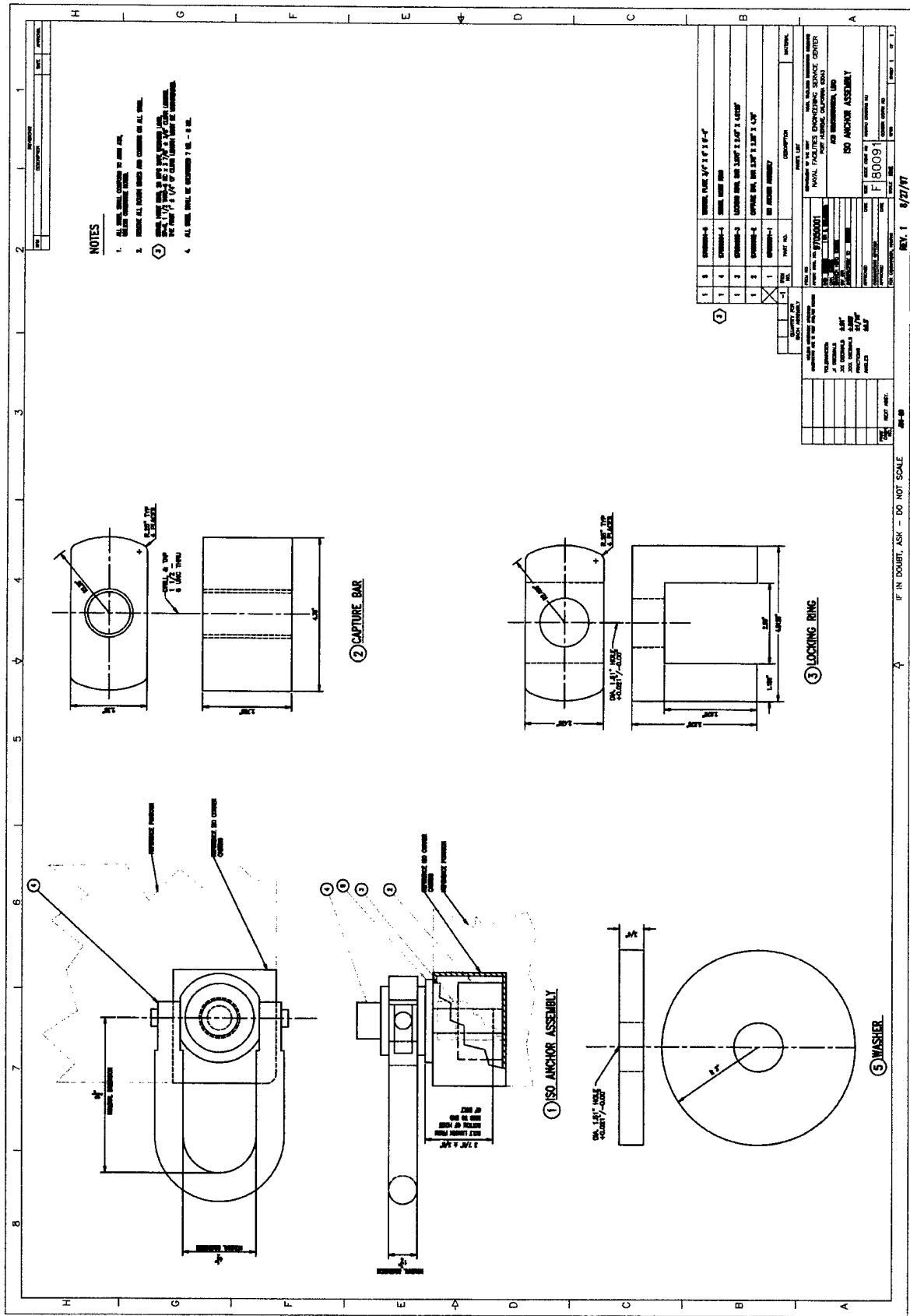

Figure 17. ISO Anchor Design Drawing # 97050001 (NFESC # 9700166)