

PL-TR-97-2128

**AEROSPACE PAYLOAD DESIGN
AND DEVELOPMENT**

Richard B. Gates

**Wentworth Labs
Wentworth Institute of Technology
550 Huntington Avenue
Boston., MA 02115**

2 October 1997

**Final Report
4 June 1992 - 4 June 1997**

19980324 030

DTIC QUALITY INSPECTED 4

Approved for public release; distribution unlimited



**PHILLIPS LABORATORY
Directorate of Geophysics
AIR FORCE MATERIEL COMMAND
HANSCOM AFB, MA 01731-3010**

"This technical report has been reviewed and is approved for publication"

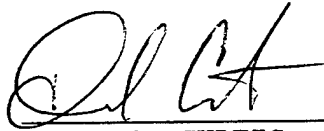

DAVID C. CURTIS
Contract Manager

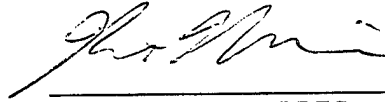

DR. ROBERT MORRIS
Branch Chief

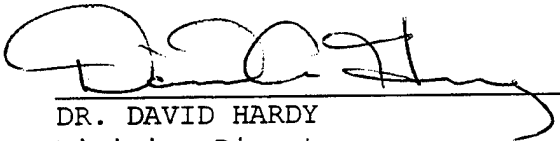

DR. DAVID HARDY
Division Director

This report has been reviewed by the ESC public Affairs Office (PA) and is releasable to the National Technical Information Service (NTIS).

Qualified requestors may obtain additional copies from the Defense Technical Information Center (DTIC). All others should apply to the National Technical Information Service (NTIS)

If your address has changed, if you wish to be removed from the mailing list, or if the addressee is no longer employed by your organization, please notify PL/IM, 29 Randolph Road, Hanscom AFB, MA 01731-3010. This will assist us in maintaining a current mailing list.

Do not return copies of this report unless contractual obligations or notices on a special document require that it be returned.

REPORT DOCUMENTATION PAGE			Form Approved OMB No 0704-0188	
<small>Public reporting burden for this collection of information is estimated to average 1 hour per response, including the time for reviewing instructions, searching existing data sources, gathering and maintaining the data needed, and completing and reviewing the collection of information. Send comments regarding this burden estimate or any other aspect of this collection of information, including suggestions for reducing this burden, to Washington Headquarters Services, Directorate for Information Operations and Reports, 1215 Jefferson Davis Highway, Suite 1204 Arlington, VA 22202-4302 and to the Office of Management and Budget, Paperwork Reduction Project (0704-0188), Washington, DC 20503.</small>				
1. AGENCY USE ONLY (Leave blank)	2. REPORT DATE 2 October 97	3. REPORT TYPE AND DATES COVERED Final (4 Jun 92 - 4 Jun 97)		
4. TITLE AND SUBTITLE Aerospace Payload Design and Development		5. FUNDING NUMBERS F19628-92-C-0096 PE 62601F PR 7659 TA 04 WU BU		
6. AUTHOR(S) Richard B. Gates				
7. PERFORMING ORGANIZATION NAME(S) AND ADDRESS(ES) Wentworth Labs Wentworth Institute of Technology 550 Huntington Avenue Boston, MA 02115		8. PERFORMING ORGANIZATION REPORT NUMBER WL-0096-97		
9. SPONSORING / MONITORING AGENCY NAME(S) AND ADDRESS(ES) Phillips Laboratory 29 Randolph Road Hanscom AFB, MA 01731-3010 Contract Manager: David Curtis/GPID		10. SPONSORING / MONITORING AGENCY REPORT NUMBER PL-TR-97-2128		
11. SUPPLEMENTARY NOTES				
12a. DISTRIBUTION / AVAILABILITY STATEMENT Approved for public release; distribution unlimited.		12b. DISTRIBUTION CODE		
13. ABSTRACT (Maximum 200 words) Summarized in this report is the work performed under Contract F19628-92-C-0096 from June 4, 1992 through June 4, 1997. Efforts consisted of the design, development, analysis and fabrication of sounding rocket, shuttle, satellite and balloon payloads, field service and instrumentation studies.				
14. SUBJECT TERMS Sounding Rocket, Payloads, Instrumentation Studies, Balloons, Instruments		15. NUMBER OF PAGES 18		16. PRICE CODE
17. SECURITY CLASSIFICATION OF REPORT Unclassified	18. SECURITY CLASSIFICATION OF THIS PAGE Unclassified	19. SECURITY CLASSIFICATION OF ABSTRACT Unclassified	20. LIMITATION OF ABSTRACT SAR	

TABLE OF CONTENTS

1.0	INTRODUCTION	1
1.1	PROGRAM SUMMARY	1
2.0	PROJECTS	2
2.1	<u>HABE</u>	3
2.2	<u>TIPACT</u>	5
2.3	<u>SPEAR</u>	6
2.4	<u>MSTI2, MSTI3</u>	7
2.5	<u>ROCKET AND AIRCRAFT SIGNATURE STUDIES</u>	8
2.6	<u>MSPP, MSPPII</u>	8
2.7	<u>CHAWS</u>	9
2.8	<u>OEDIPUS</u>	10
2.9	<u>SPASIII</u>	10
2.10	<u>SPERT</u>	11
2.11	<u>BMT</u>	11
2.12	<u>BWL</u>	11
2.13	<u>CHOP</u>	11
2.14	<u>ADPT</u>	11
2.15	<u>MML-1</u>	12
3.0	PERSONNEL	13
4.0	CHARTS AND GRAPHS	14
4.1	ACTIVITY BY QUARTER	14

1.0 INTRODUCTION

Summarized in this report is the work performed under contract F19628-92-C-0096 from June 4, 1992 to June 4, 1997. Wentworth provided personnel, materials, facilities and services to design and fabricate aerospace scientific payloads, conducted instrumentation studies, developed payload instrumentation systems, performed qualification and acceptance level testing, provided field integration, pre-launch, launch and post-launch support and refurbished, tested and delivered recovered payloads and instrumentation systems. Efforts consisted of engineering support for shuttle type payloads, of Mid-Deck Payloads, Cargo Bay payloads and GAS Can Payloads, for satellite type payloads, for complex sounding rocket payloads, for balloon type payloads and for smaller sounding rocket type payloads.

1.1 PROGRAM SUMMARY

Wentworth's primary task was to provide design, engineering and fabrication support for Phillips Laboratory toward the development of payloads for infrared measurements and other physical science experiments in space. Specific services provided included mechanical design and analysis of mechanical pieces and electro-mechanical devices, development of cost effective fabrication techniques, testing and field support of the hardware. Also provided were the design, fabrication, assembly, testing and integration of electronic devices including flight suitable cabling and harnesses. Wentworth's long experience in payload support contributed to being a cost effective supplier of diverse services at close proximity to Phillips Laboratory. The results of this contract added to the existing success record and expertise of Wentworth and enabled us to win the succeeding contract with Phillips Laboratory, F19628-95-C-0224.

2.0 PROJECTS

An overview of the 20 TRN projects that Wentworth participated in is presented in this section.

The format by which these TRN's are reviewed is as follows:

Title - Acronym or project name.

TRN #

() - 3 digit project number from WIT's Contract Reporting System.

Dates - Period of time during which work was performed by WIT.

Configuration/Mission - Launch vehicle, brief payload and mission description
(when known).

Task Elements - Wentworth's level of effort in the project.

Summary - Results of Wentworth's efforts and launch date (if known).

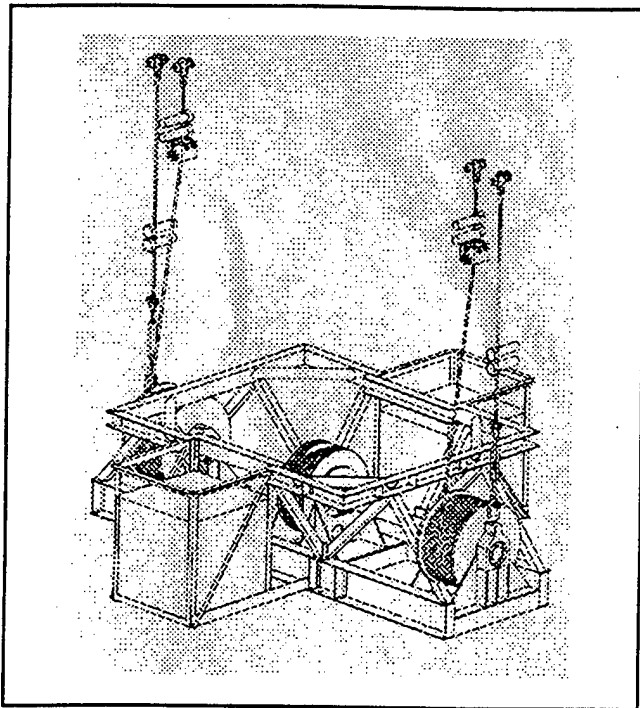

Figure 1 HABE Brake System

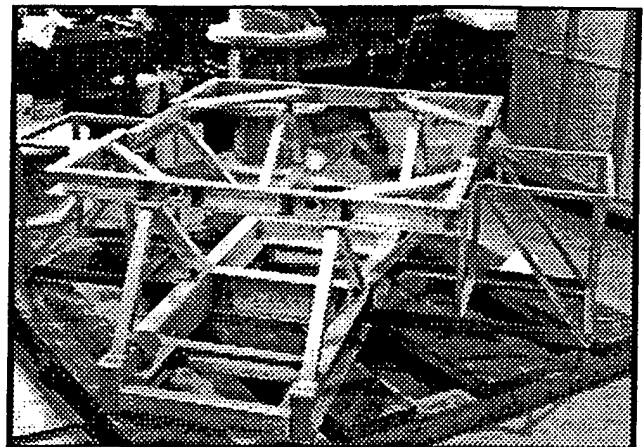

Figure 2 HABE Fabricated Structure

2.1 HABE (683.692) - June 1992 - March 1995

TRN 0096001

2.1.1 Configuration/Mission - A test program for a tandem (tow and launch) balloon (High Altitude Balloon Experiment) system.

2.1.2 Task Elements - Refurbished Flat Rack platform, designed and analyzed Launch Platform, fabricated and tested Launch Platform, Designed and analyzed Balloon Flight Canister Assembly, brake and reel assembly, brake and reel space frame, gas transfer tube, parachute attachments and Experiment Canister interface, fabricated and tested Balloon Flight Canister Assemblies, provided tow balloon, prototype balloon system and parachutes

2.1.3 Summary - Ground testing of systems was successful. A flight mishap occurred during the flight of CHECK0 on June 16, 1993. All Wentworth associated hardware performed well.

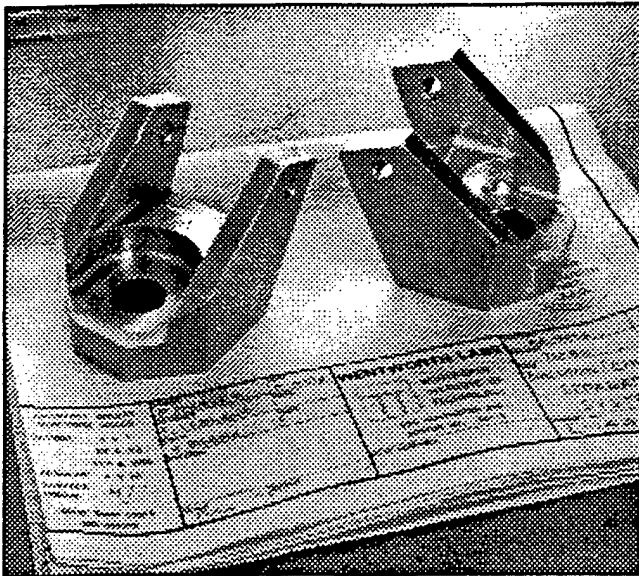

Figure 3 HABE Chute Bracket

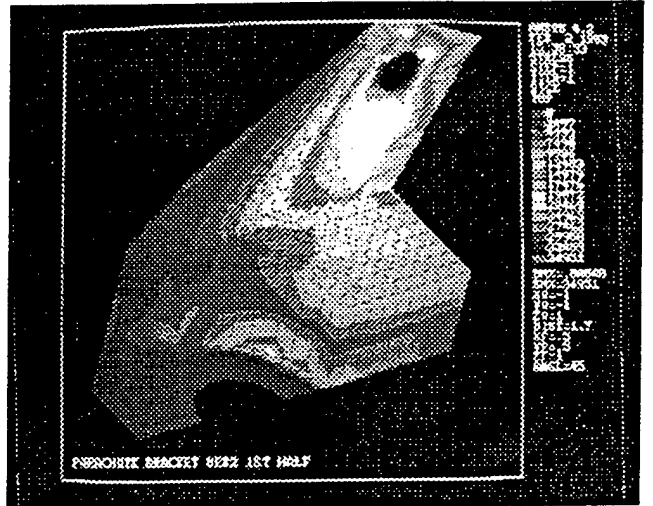

Figure 4 HABE FEA Analysis

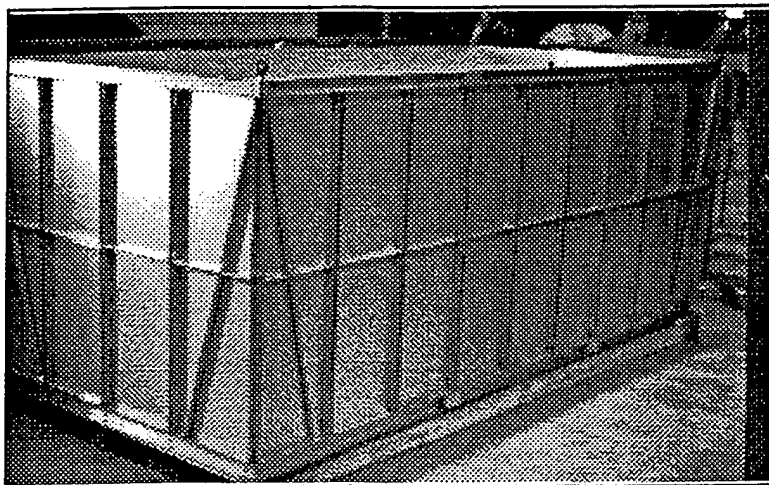

Figure 5 HABE Balloon Box

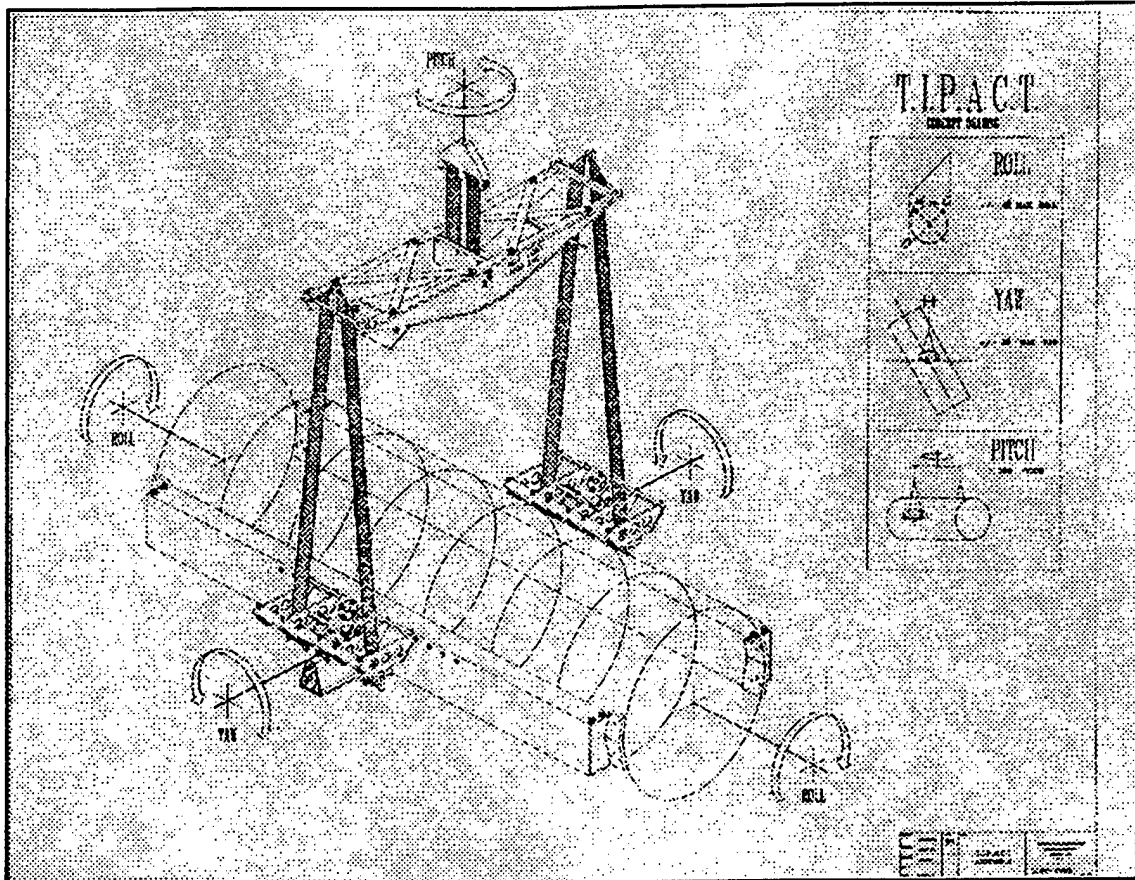

Figure 6 TIPACT Assembly Drawing

2.2 TIPACT (688) August 1992 - January 1994

TRN 0096002

2.2.1 Configuration/Mission - TIPACT (Totally Integrated Payload Attitude Control Tester) is a device to test inertial guidance units for sounding rockets and replace less sophisticated one degree of freedom systems.

2.2.2 Task Elements - Purchase and fabricate the mechanical parts for TIPACT.

2.2.3 Summary - Parts were delivered on time and to print.

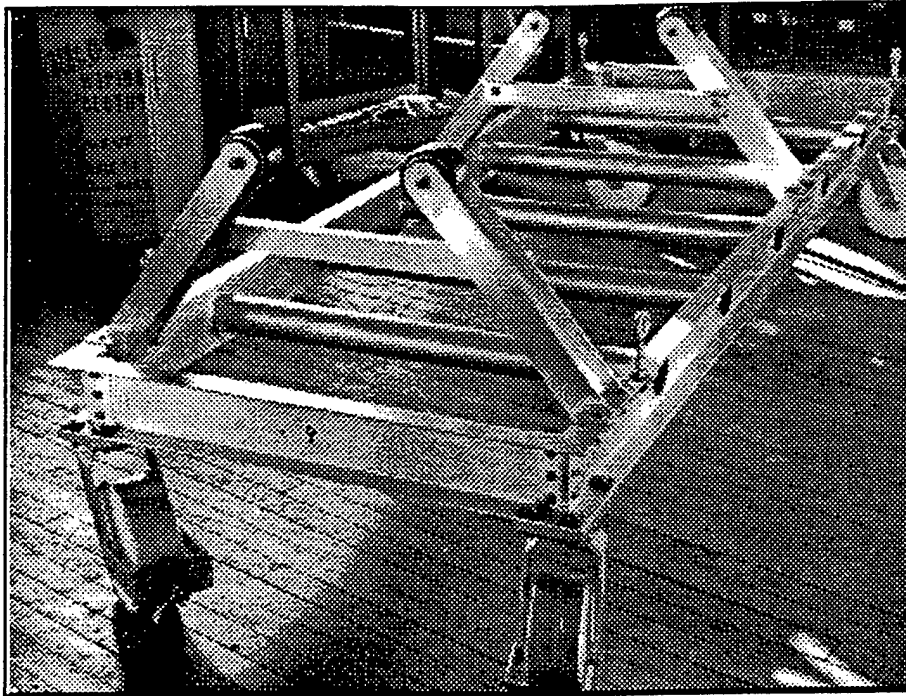

Figure 7 SPEAR III Cart

2.3 SPEARIII (689) - September 1992 - January 1993

TRN 0096005

2.3.1 Configuration/Mission - Space Power Experiment Aboard Rocket (SPEAR III).

2.3.2 Task Elements - Refurbish two payload handling carts and fabricate one shaker plate for the SPEAR III program.

2.3.3 Summary - Parts delivered on time. Launched successfully March 15, 1993

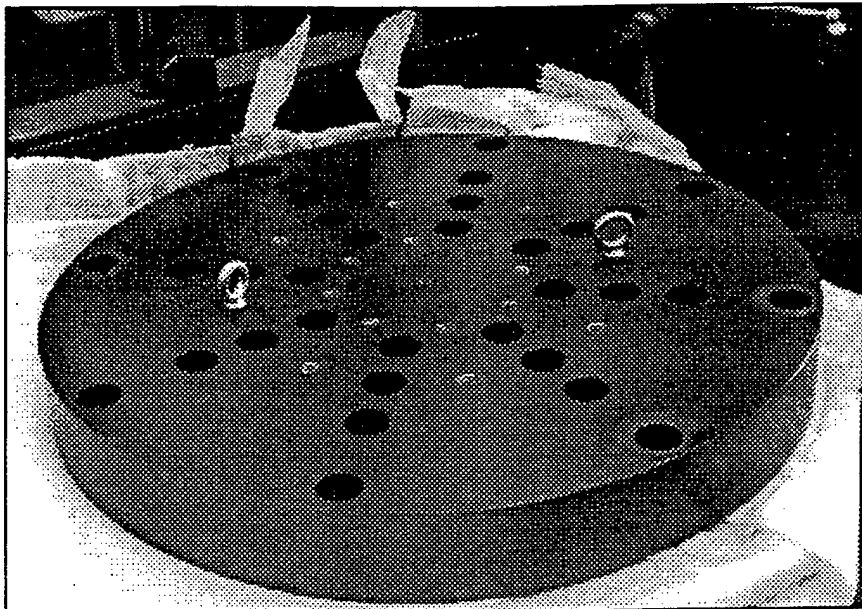

Figure 8 SPEAR III Shake Plate

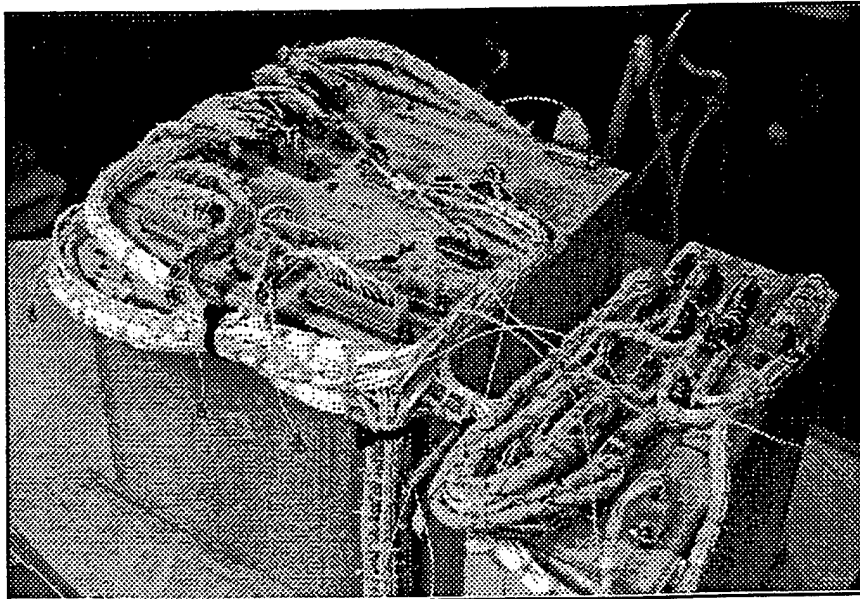

Figure 9 MSTI3 Harnessing

2.4 MSTI 2 (690) - November 1992 - February 1994
MSTI 3 (698,700,709) - June 1994 - April 1996

TRN 0096006

TRN 0096006, 0096013

2.4.1 Configuration/Mission - The Miniature Seeker Technology Integration (MSTI) program consists of a series of small satellites used to demonstrate new sensor technologies for the detection and targeting of theater and ballistic missiles.

2.4.2 Task Elements - Design, develop, fabricate, test and provide flight support for the payload experiment package.

2.4.3 Summary - Electronics support was provided to MSTI 2 (flight in March 1994) and MSTI 3 (flight in May 1996).

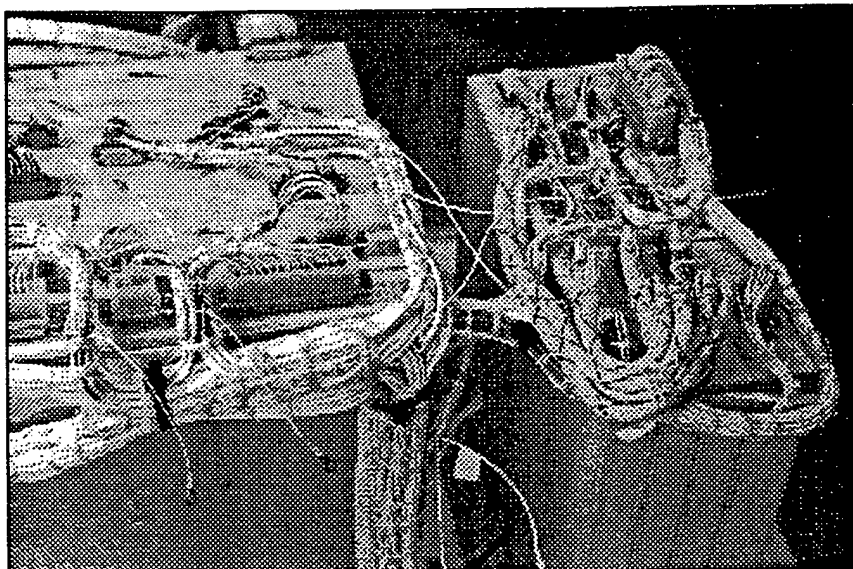

Figure 10 MSTI3 Harnessing

2.5 Rocket and Aircraft Signature Studies (679,680,681,687,686,689) - June 1992 - July 1994
TRN 0096007

2.5.1 Configuration/Mission - The Rocket and Aircraft Signature Study is a rocket-borne experiment that will characterize the heatshield/antenna window properties and radar signature of hyper sonic flight vehicles.

2.5.2 Task Elements - Instrumentation was designed and fabricated to support the testing of recently developed materials over extended temperature and frequency ranges.

2.5.3 Summary - All equipment provided performed satisfactory.

2.6 MSPP (693) August 1993 - September 1994
MSPPII (705) September 1994 - November 1994

TRN 0096008

TRN 0096015

2.6.1 Configuration/Mission - Miniaturized Space Plasma Probe

2.6.2 Task Elements - Design and fabricate CHAWS-type digital RPA housings, parts and sections, procure Micro Channel Plates.

2.6.3 Summary - Parts were delivered on time and to print.

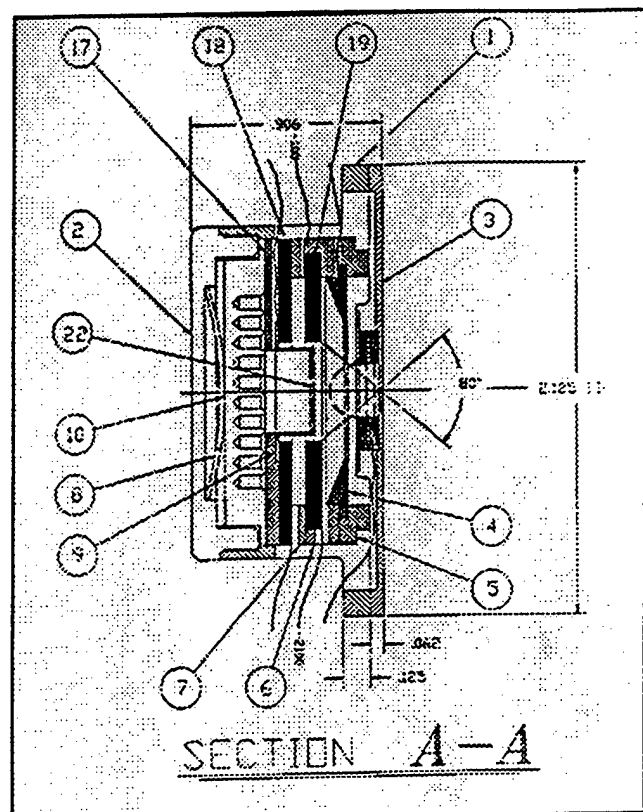

Figure 11 Micro Channel Plate Holder, Part of the Wake Ram Sensor for CHAWS

2.7 CHAWS (694) - September 1993 -
November 1994 TRN 0096009

2.7.1 Configuration/Mission - Charge
Hazard and Wake Studies

2.7.2 Task Elements - Developed
drawings of CHAWS Langmuir Probe and
digital RPA's.

2.7.3 Summary - Drawings were deliv-
ered satisfactorily.

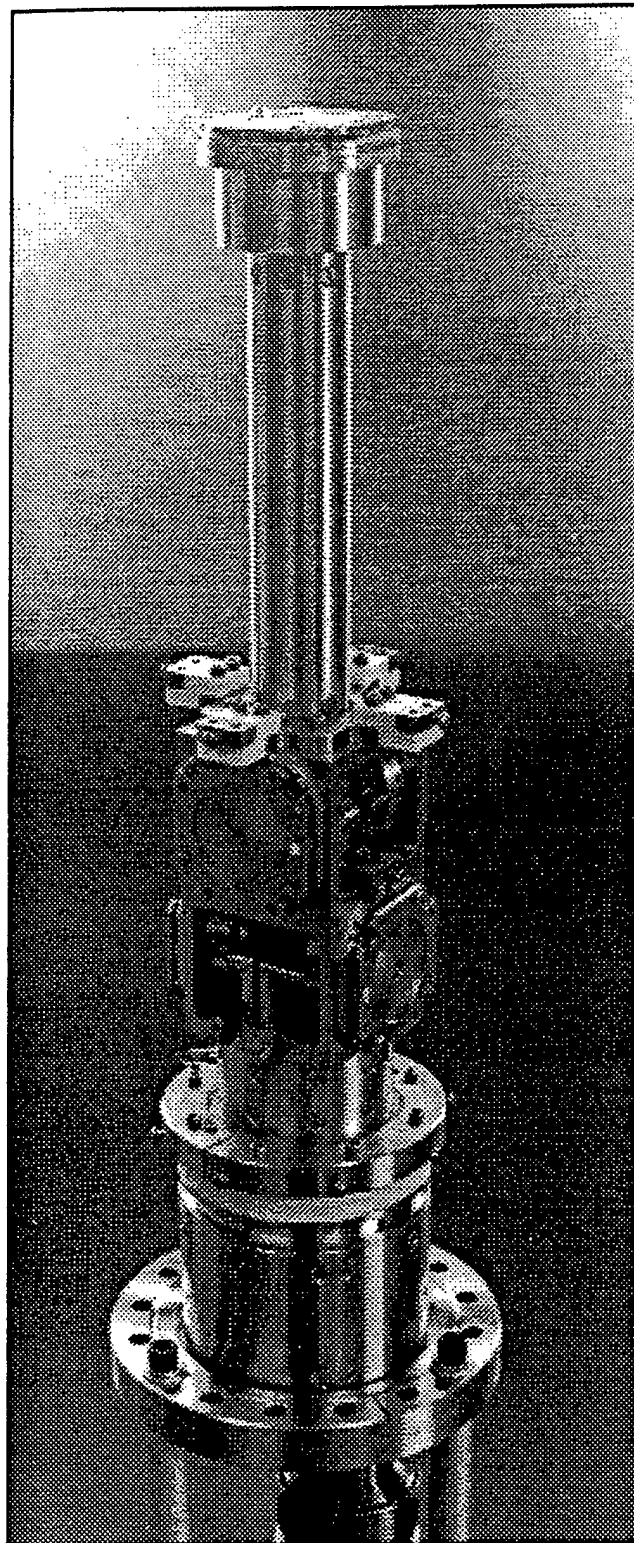
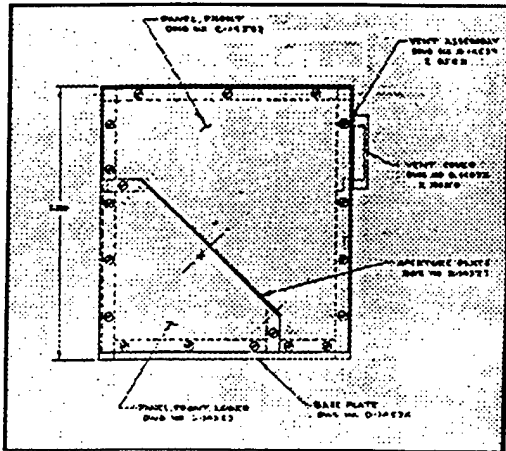
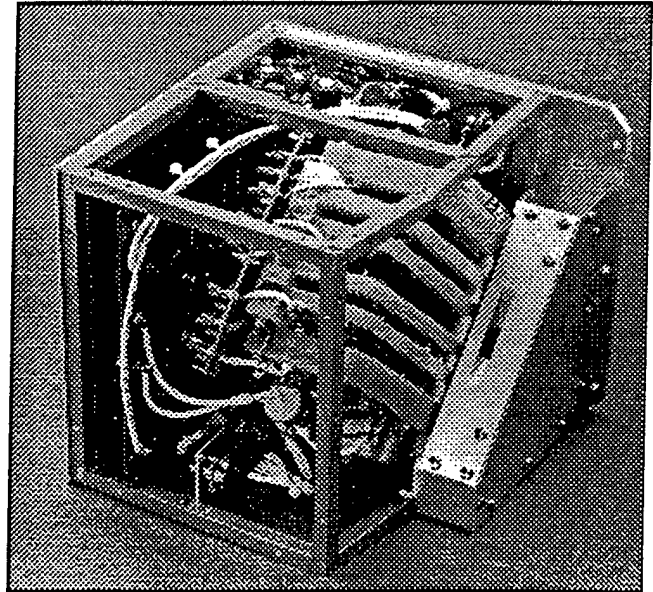

Figure 12
Wake Side Plasma Sensor used
on CHAWS



Figures 13 & 14 OEDIPUS Top Assembly



2.8 OEDIPUS (695) - April 1993 - June 1994
TRN 0096010

2.8.1 Configuration/Mission - Oedipus-C is a Black Brant sounding rocket experiment consisting of an Electrostatic Particle Instrument formed by a Sensor and an Electronic /Correlator.

2.8.2 Task Elements - Design and fabricate the boxes for the Electronics/Correlator and Sensor.

2.8.3 Summary - Hardware delivered on time and to print. Launch date January 1995.

2.9 SPAS III (696) - September 1993 - December 1994
TRN 0096011

2.9.1 Configuration/Mission - SPAS III is a shuttle borne pallet experiment..

2.9.2 Task Elements - Design, analyze, fabricate and support camera baffles for experiment package.

2.9.3 Summary - Hardware proved satisfactory in ground tests.

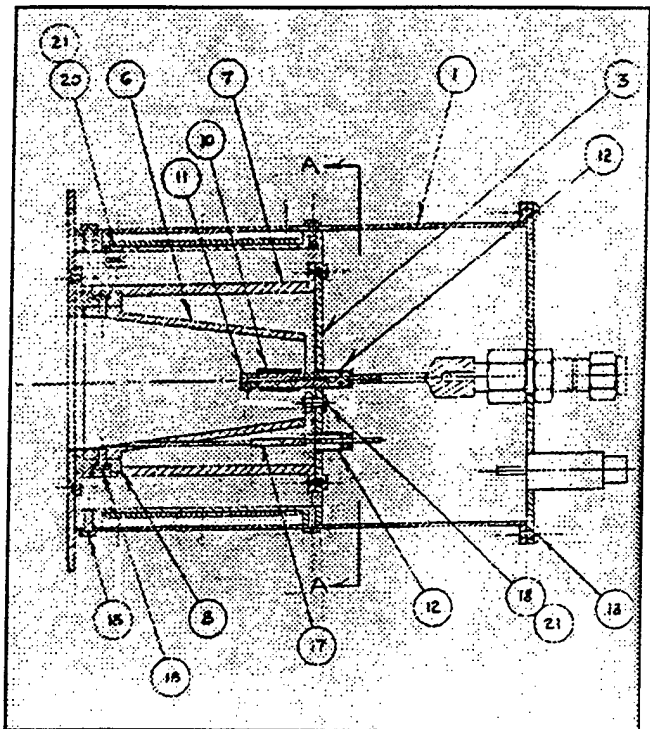

Figure 15 Cathode Assembly used on SPAS III

2.10 SPERT (697) - December 1993 - August 1994 TRN 0096012

2.10.1 Configuration/Mission - Satellite Plume Experiment Rocket Targets (SPERT) are sounding rocket systems for use as target vehicles for space borne plume identification and characterization experiments.

2.10.2 Task Elements - Wentworth procured the SERGEANT motors, fixtures and tooling and related engineering services for the launch effort.

2.10.3 Summary - Hardware was delivered. Launch in late 1995.

2.11 BMT (701,702,704,707) - July 1994 - January 1996 TRN 0096014

2.11.1 Configuration/Mission - Ballistic Missile Technologies Program

2.11.2 Task Elements - Design, develop, fabricate and test ground support equipment and perform instrumentation studies to support the Ionospheric Physics Division's BMT effort.

2.11.3 Summary - Work completed satisfactorily.

2.12 BWL (706,710) - November 1994 - August 1995 TRN 0096016

2.12.1 Configuration/Mission - Ballistic Winds Lidar

2.12.2 Task Elements - Design, develop, fabricate, test and provide flight support for the payload experiment package for the BWL B-52 flight assessment program.

2.12.3 Summary - Hardware was provided for the flight program and design services given for the Lidar trailer.

2.13 CHOP (708,715) - December 1994 - May 1996 TRN 0096017

2.13.1 Configuration/Mission - Countermeasures Hands-On Program is designed to test the concept of rapid existing hardware integration into sounding rocket experiments. Long lead hardware/software is discouraged, streamlined, ~skunkworks type~ programs are desired.

2.13.2 Task Elements - Design and fabricate, or procure sounding rocket payloads and systems for use in support of the CHOPs program, perform analysis as required, and provide engineering support for launch and recovery.

2.13.3 Summary - Hardware was delivered on time.

2.14 ADPT (712) - August 1995 - August 1996 TRN 0096018

2.14.1 Configuration/Mission - Aerospace Diagnostics and Payload Technologies program

2.14.2 Task Elements - Perform instrumentation studies, design, develop, fabricate and test ground support equipment as required to support the Ionospheric Physics Division ADPT.

2.14.3 Summary - Studies were performed satisfactorily in the 1995 - 1996 time period.

2.15 MML1 (713,718,716,720) - September 1995 - May 1997 TRN 0096020

2.15.1 Configuration/Mission - Minuteman/LEAP-1

2.15.2 Task Elements - Design and fabricate, or procure (as appropriate) sounding rocket payloads and systems for use in support of the MML-1 program, perform analysis as required, and provide engineering support for the launch and recovery.

2.15.3 Summary - Services were provided in the above time period, program has yet to launch.

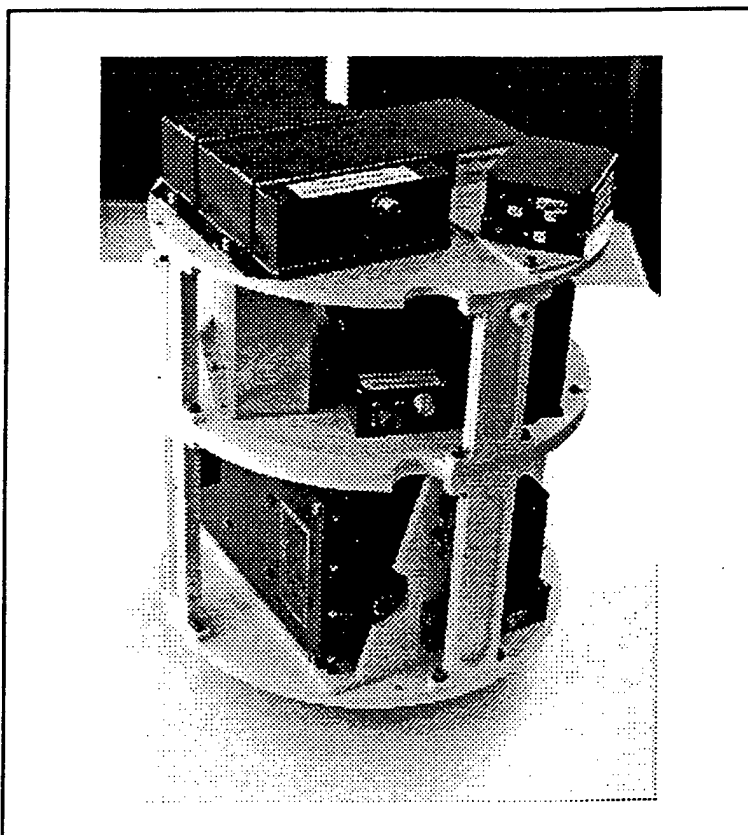

Figure 17 MinuteMan LEAP-1 Mockup

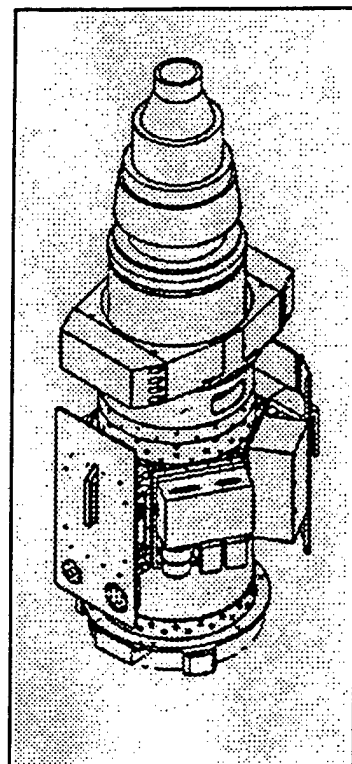

Figure 16
MinuteMan LEAP-1
Payload

3.0 PERSONNEL

The value of experience should not be undervalued when rating an organization's capability to provide quality aerospace hardware and services at cost effective rates. The following individuals contributed to the projects as outlined in this report.

NAME	TITLE	YEARS TOTAL		EDUCATION	
		AT WIT	YEARS EXP		
Arnold	Susan	Research Chemist	1	4	PHD
Benassi	Howard	Super, Manuf.	39	39	AS
Dentamaro	Anthony	Research Physicist	1	12	PHD
Fritzler	Frederick	Instr Maker	45	45	AS
Gambale	Alfonso	Instr Maker	24	24	CERT
Gates	Richard	PI/ME	12	28	BS
Hartnett	Paul	Mech Designer	37	37	AS
Hurley	Patrick	Mech Designer	18	37	AS
Iarson	Jon	Instr Maker	12	12	BS
LeBlanc	Edgar	Super, Design	46	46	AS
Lefteriou	Nicholas	EE Tech	4	25	AS
Meads	Roger	Research Chemist	1	5	PHD
Miller	Thomas	Physicist	1	29	PHD
Morin	Richard	EE	2	30	BS
Mundis	Paul	EE Tech	32	49	AS
Seeley	John	Research Chemist	1	2	PHD
Silva	Joseph	Instr Maker	11	35	AS
Smart	Lawrence	EE Tech	30	30	BS
Thomas	Joseph	Chemist	1	18	PHD
Tracy	Fred	EE Tech	1	40	AS
Trzcinski	Edmund	EE	1	37	BS
Van Doren	Jane	Research Chemist	1	15	PHD
Williamson	John	ME/EE	7	7	BS

4.0 CHARTS AND GRAPHS

4.1 ACTIVITY BY QUARTER

The following chart is provided to allow tracking of Wentworth's activities on specific projects by quarter.

SPENDING ACTIVITY BY QUARTER			92	92	93	93	93	93	94	94	94	94	95	95	95	95	96	96	96	96	97	97
CALENDAR YEAR			1	2	3	4	5	6	7	8	9	10	11	12	13	14	15	16	17	18	19	20
TRN	NAME	PROJECT																				
0096001	HABE	683	X	X		X	X	X	X		X	X	X	X								
	HABE BRAH	692			X																	
	HABE/SIE	714														X						
	HABE/M	719															X			X		
	HABE/B	721															X	X	X			
0096002	TIPACT	688	X	X	X		X	X	X													
	POLARCAB	684	X				X															
0096003	ENLOE GP	682	X	X										X								
	MURPHY	685	X	X	X																	
0096004	CONFORM	691		X		X																
0096005	SPEARIII	689		X	X									X								
0096006	MSTI2	690		X	X	X	X	X	X													
	MSTI3	698						X	X	X	X	X										
0096007	MUNDIS	679	X	X	X	X	X	X	X	X	X											
	WILLIAMSC	680	X	X	X	X	X	X	X	X												
	VANDOREN	681	X	X	X																	
	MILLER	687	X	X	X	X																
	CONCORD	686	X		X																	
	TRZCINSKI	699								X	X											
0096008	MSPP	693					X	X		X	X											
0096009	CHAWS	694					X	X		X	X	X										
0096010	OEDIPUS	695			X	X	X	X	X	X												
0096011	SPASIII	696					X	X	X	X	X	X										
0096012	SPERT	697							X	X	X											
0096013	MSTI3	700								X	X	X	X	X	X	X						
	MSTIHARN	709													X	X	X	X	X			
0096014	BMT/WILLIA	701									X	X	X	X	X	X	X					
	BMT/MUND	702									X	X	X	X	X	X	X					
	BMT/TRZCI	704									X	X	X	X	X							
	BMT/CONC	707										X										
0096015	MSPP2	705										X										
0096016	LIDAR	706										X	X									
	LIDAR2	710													X	X	X					
0096017	CHOP	708										X	X	X	X	X	X	X	X	X	X	X
	CHOP/SIE	715													X							
0096018	ADPT	712													X				X			
0096019	CHOPII	711																				
0096020	MMLEAP	713														X	X	X				
	LEAP/SIE	718														X						
	DMORIN	716														X	X	X	X			
	LEAP/M	720														X	X	X	X		X	X