

292053

JPRS 84229

31 August 1983

# West Europe Report

No. 2196

**DISTRIBUTION STATEMENT A**

Approved for public release  
Distribution Unlimited

**DTIC QUALITY INSPECTED 4**

19980320 076

**FBIS**

**FOREIGN BROADCAST INFORMATION SERVICE**

REPRODUCED BY  
NATIONAL TECHNICAL  
INFORMATION SERVICE  
U.S. DEPARTMENT OF COMMERCE  
SPRINGFIELD, VA. 22161

5  
232  
A11

#### NOTE

JPRS publications contain information primarily from foreign newspapers, periodicals and books, but also from news agency transmissions and broadcasts. Materials from foreign-language sources are translated; those from English-language sources are transcribed or reprinted, with the original phrasing and other characteristics retained.

Headlines, editorial reports, and material enclosed in brackets [] are supplied by JPRS. Processing indicators such as [Text] or [Excerpt] in the first line of each item, or following the last line of a brief, indicate how the original information was processed. Where no processing indicator is given, the information was summarized or extracted.

Unfamiliar names rendered phonetically or transliterated are enclosed in parentheses. Words or names preceded by a question mark and enclosed in parentheses were not clear in the original but have been supplied as appropriate in context. Other unattributed parenthetical notes within the body of an item originate with the source. Times within items are as given by source.

The contents of this publication in no way represent the policies, views or attitudes of the U.S. Government.

#### PROCUREMENT OF PUBLICATIONS

JPRS publications may be ordered from the National Technical Information Service, Springfield, Virginia 22161. In ordering, it is recommended that the JPRS number, title, date and author, if applicable, of publication be cited.

Current JPRS publications are announced in Government Reports Announcements issued semi-monthly by the National Technical Information Service, and are listed in the Monthly Catalog of U.S. Government Publications issued by the Superintendent of Documents, U.S. Government Printing Office, Washington, D.C. 20402.

Correspondence pertaining to matters other than procurement may be addressed to Joint Publications Research Service, 1000 North Glebe Road, Arlington, Virginia 22201.

## WEST EUROPE REPORT

No. 2196

### CONTENTS

#### THEATER FORCES

##### FEDERAL REPUBLIC OF GERMANY

- Need for Fighter Aircraft in 1990's  
(A. Baerwolf; DIE WELT, 28 Jul 83)..... 1

#### TERRORISM

##### SWEDEN

- Armenian Terrorist Group ASALA Active in Stockholm  
(Jan Malmberg; DAGENS NYHETER, 12 Aug 83)..... 4

##### TURKEY

- Turks Assess Radio Moscow Attack on ASALA  
(HURRIYET, 8 Aug 83)..... 6
- Interview With Member of Kurdish Workers Party  
(LE VIF, 30 Jun 83)..... 8

#### ENERGY ECONOMICS

##### CYPRUS

- Refinery Stoppages Foster Fuel Imports  
(I SIMERINI, 1 Aug 83)..... 13

DENMARK

Briefs  
Oil Products Consumption Drops 14

NORWAY

Higher Oil Prices Increasing Interest in Hydroelectric Power  
(Eivind Fossheim; AFTENPOSTEN, 25 Jul 83)..... 15

Statoil Director: Requests To Drill Aboard Were Refused  
(Brit Myhrvold; AFTENPOSTEN, 11 Aug 83)..... 17

SWEDEN

Briefs  
Increased Gotland Oil Production 18

ECONOMIC

EUROPEAN AFFAIRS

Study Compares Business Performance in Nordic Countries  
(DAGENS NYHETER, 11 Aug 83)..... 19

CYPRUS

Balci Urges Turkish-Cypriot Initiative in Economics  
(Ergun Balci; CUMHURIYET, 9 Jun 83)..... 20

Correct Planning Needed for Relations With EEC  
(O FILELEVTHEROS, 31 Jul 83)..... 23

DENMARK

Industrial Recovery Now Fully Underway  
(Erik Bendt Rasmussen; BERLINGSKE TIDENDE, 4 Aug 83)..... 25

Investment in Industry Is Rapidly Increasing  
(Frank Dahlgaard; BERLINGSKE TIDENDE, 23 Jul 83)..... 27

Competition in Fisheries Responsible for Faeroes Trade  
Loss  
(BERLINGSKE TIDENDE, 25 Jul 83)..... 29

FRANCE

Research Group Predicts 1983-1984 Unemployment, Trade  
Figures  
(Pierre Locardel; LES ECHOS, 16 Jun 83)..... 30

ICELAND

Briefs  
New Foreign Loan Taken 33

ITALY

Unemployment, Underemployment in South Examined  
(Antonio Franceschini; RASSEGNA SINDACALE, 20 May,  
3 Jun 83)..... 34

NORWAY

Paper Comments on OECD Recommendations on Economy  
(Editorial; AFTENPOSTEN, 18 Jul 83)..... 46

Trade Surplus for First Six Months of 1983 Almost Doubles  
(Bjorn H. Tretvoll; AFTENPOSTEN, 14 Jul 83)..... 48

SPAIN

Madrid Prefers Dialogue to Economic War Over Gibraltar  
(Jose V. Colchero; YA, 2 Aug 83)..... 50

TURKEY

Full-Scale Campaign To Intensify Tax Auditing  
(Rafet Genc; CUMHURIYET, 10 Jul 83)..... 52

TUSIAD Report on Short, Medium-Term Planning  
(DUNYA, 9 Jul 83)..... 54

POLITICAL

CYPRUS

AKEL-CPSU Joint Communique on Papaioannou Visit  
(KHARAVGI, 31 Jul 83)..... 56

AKEL Deputy Stresses Need for Press Attaches' Guidance  
(O AGON, 1 Aug 83)..... 59

Surprise Higher Ranks Police Promotions Announced  
(O AGON, 30 Jul 83)..... 61

Concern Expressed Over Turkish Propaganda Progress  
(O FILELEVETHEROS, 31, 26 Jul 83)..... 63

Enlightenment Activities  
Hollandair Flights

FEDERAL REPUBLIC OF GERMANY

Position of Parties for Election in Hesse  
 (Jochen Siemens; FRANKFURTER RUNDSCHAU, 1 Aug 83)..... 65

FRANCE

European Independence Movement Pre-Election Manifesto  
 (LE MONDE, 27 Jul 83)..... 69

Gallois on Disarmament Negotiations, U.S., Soviet Strength  
 (Pierre-Marie Gallois; POLITIQUE INTERNATIONALE,  
 Summer 83)..... 75

GREECE

Bases Agreement Viewed From Various Political Angles  
 (Various sources, various dates)..... 88

Economic Reasons Preponderant, Editorial  
 Foreign, Domestic Policy Sides, by Khristos Rozakis  
 Rozakis' View Contested, by V. Filias  
 KKE-PASOK Relations, Editorial  
 1983 Agreement No Different, Editorial  
 Agreement Within Aegean Context, by Kostas  
 Angelopoulos  
 PASOK's Victory Claim

Problems Raised by Spreading of Chadian Conflict  
 (Rikhardos Someritis; I KATHIMERINI, 15 Aug 83)..... 101

ICELAND

Presidential Secretary Halldor Reynisson on Peace Movement  
 (Staksteinar; MORGUNBLADID, 16 Jul 83)..... 103

NORWAY

Poll Measures Voter Loyalty to Parties as Elections Near  
 (Bibi Vance; AFTENPOSTEN, 26 Jul 83)..... 106

Paper: Good Poll Result for Conservatives  
 (Editorial; AFTENPOSTEN, 26 Jul 83)..... 108

Opposition, Conservative Newspaper Comment on Madrid Meeting  
 (Editorial; ARBEIDERBLADET, 16 Jul 83; AFTENPOSTEN,  
 18 Jul 83)..... 110

Labor Party Paper Satisfied  
 Conservation Paper Less Optimistic

Gallup Organization Reorganized; New Poll Schedule (AFTENPOSTEN, 14 Jul 83).....	113
Socialist-Left Party's Koritzinsky Discusses Political Goals (Anne-Lise Hammer; AFTENPOSTEN, 26 Jul 83).....	115
Starting Foreign Affairs Committee To Visit Central America (AFTENPOSTEN, 28 Jul 83).....	118
PORTUGAL	
Mota Amaral: Azores Not Only a Military Fortress (EXPRESSO REGIOES, 30 Jul 83).....	119
Eanes, Soares: Questions About 1985 Presidential Elections (Pedro d'Assuncao; EXPRESSO, 30 Jul 83).....	122
Political Motives Invoked for Garcia dos Santos Issue (Jose Miguel Judice; O DIABO, 2 Aug 83).....	126
Peace Festival Suffers From Reduced Attendance (POVO LIVRE, 27 Jul 83, AVANTE, 28 Jul 83).....	130
PSD Youth Absent Foreigners Barred	
Present Status, Ambitions of Right-Wing Sector Analyzed (Joao Carlos Espada; EXPRESSO, 16 Jul 83).....	132
Trial of Saraiva de Carvalho Postponed (O JORNAL, 29 Jul 83).....	138
Briefs	
Planning Official Resigns	139
USSR Delegation Departs	139
ALADI Membership	139
SPAIN	
PCE-EPK Official Interprets Basque Political Currents (Ignacio Latierro Interview; MUNDO OBRERO, 22-28 Jul 83).....	140
SWEDEN	
Poll Finds Peace Issue Seen as Increasingly Vital by Voters (Sven Svensson; DAGENS NYHETER, 17 Jul 83).....	143

Inga Thorsson To Lead Commission on Disarmament (DAGENS NYHETER, 15 Jul 83).....	147
Paper Views Problems of Political Parties' Youth Wings (Bosse Schon; SVENSKA DAGBLADET, 15 Jul 83).....	148
Paper Cites Lack of Balance Regarding East, West by Bodstrom (Editorial; SVENSKA DAGBLADET, 5 Jul 83).....	151
Wage-Earner Funds Expected To Be Predominant Fall Issue (Morten Fyhn; AFTENPOSTEN, 11 Aug 83).....	153

#### TURKEY

Barlas on State's Lack of Resolution in Facing Problems (Editorial, Mehmet Barlas; MILLIYET, 10 Jul 83).....	156
Turkish Labor Party Trial Continues in Istanbul (CUMHURIYET, 2 Aug 83).....	158
Goze Gives Wary Eye to Social Democrat Party (Ergum Goze; TERCUMAN, 9 Jun 83).....	160
Parties Race To Organize on Provincial Level (TERCUMAN, 10 Jul 83).....	162
MDP's Sunalp Promotes Party, Discusses Ideology (CUMHURIYET, 3 Aug 83).....	164
Birand on Dreary State of Franco-Turkish Relations (M. Ali Birand; MILLIYET, 9 Jun 83).....	165

#### MILITARY

##### EUROPEAN AFFAIRS

Norway, Sweden To Sign Arms Purchase Pact (Bjorn Lindahl; DAGENS NYHETER, 11 Aug 83).....	167
--	-----

##### DENMARK

Air Force Chief Replies to Charge of Defense Shortcomings (Johannes Sjøtho; BERLINGSKE TIDENDE, 4 Aug 83).....	169
Retired Captain Says Debate on Defense Should Be Broader (F. F. Bork; BERLINGSKE TIDENDE, 4 Aug 83).....	171
Colonel Charges Political Leaders With Ignoring Military (BERLINGSKE TIDENDE, 23 Jul 83).....	173

Briefs		
	F-16 Modernization Contract Lost to Belgium	177
	Defense Command Undergoing Reorganization	177
FRANCE		
Briefs		
	Matra Expands Signes Plant	178
	Aeronautics Subcontractors Lose Business	178
NORWAY		
	Defense Chief: May Reduce Operations Due To Lack of Funds (Ragnvald Naero; AFTENPOSTEN, 3 Aug 83).....	179
	Defense Ministry Official Urges Measures To Retain Pilots (Tore Tollersrud; AFTENPOSTEN, 4 Aug 83).....	181
	Soviets Remove Parts From Crashed Helicopter on Svalbard (Torill Nordent; AFTENPOSTEN, 25 Jul 83).....	183
	Civil Defense Study Commission Urges Gas Masks for All (Liv Hegna; AFTENPOSTEN, 4 Aug 83).....	184
SWEDEN		
Briefs		
	Civil Defense Orders Protective Material	186
TURKEY		
	Ankara Worried Over Iranian Threat to Oil Pipeline (CUMHURIYET, 3 Aug 83).....	187
	Analysis of Ankara Approach to U.S.-Greek Base Accord (Sedat Ergin; CUMHURIYET, 2 Aug 83).....	189
AEROSPACE SCIENCES		
EUROPEAN AFFAIRS		
	SEP, MBB 1982 Studies on Cryogenic Engine for 1990's Ariane (S. Eury, et al.; L'AERONAUTIQUE ET L'ASTRONAUTIQUE, No 99, 1983-2 pp 70-77).....	191

OCEAN ISSUES

EUROPEAN AFFAIRS

- Sweden's Foreign Minister on Kattegatt Dispute With Denmark  
(Birgitta Edlund; DAGENS NYHETER, 25 Jul 83)..... 206
- Swedish Expert Supports Denmark in Kattegat Oil Dispute  
(Goran Melander; DAGENS NYHETER, 12 Aug 83)..... 208
- Outcome of Swedish-Danish Dispute Will Interest USSR  
(AFTENPOSTEN, 9 Aug 83)..... 211

NORWAY

- Whaling Commission's Decision on Quotas To Create Problems  
(Editorial; AFTENPOSTEN, 26 Jul 83)..... 214

SWEDEN

- Danes Begin Oil Search in Area of Kattegatt Sweden Disputes  
(Ake Ringberg; DAGENS NYHETER, 22 Jul 83)..... 216

GENERAL

EUROPEAN AFFAIRS

- Increasing Number of Nations Doing Research on Svalbard  
(Torill Nordeng; AFTENPOSTEN, 9 Aug 83)..... 217

NORWAY

- Delegation Leader: Antarctica Conference 'Successful'  
(John Harbo; AFTENPOSTEN, 26 Jul 83)..... 220

## NEED FOR FIGHTER AIRCRAFT IN 1990's

Bonn DIE WELT in German 28 Jul 83 p 6

[Article by A. Baerwolf: "The Air Force Will Be Circled ut ith Its Phantom"]

[Text] The project is called "Jaeger 90" (Fighter 90). It will eliminate the weak point in German air defense: the Phantom, which can no longer compete in air combat maneuverability. A fighter plane for the year 2000 and beyond is needed.

Officers of the German General Staff wrestle with the adversities of the hottest long range project of the Luftwaffe in shabby barracks on the Bonn Hardthoehe. TKF 90 was the magical formula according to which a new tactical fighter aircraft would in the nineties take over the role of the hopelessly aged F4F Phantom.

But the technological tempest, the uncertainties of the opponents' initiatives, and the increasing gap between rising costs of new weapons and the available funds have more and more clouded the project. Finally the officers in the dilapidated Bonn barracks in their Air Force uniforms with red piping, have given the signal to rename project TFK 90 as "Fighter 90." With this decision the dense fog which has clouded the project is lifting. A futuristic aircraft is appearing on the horizon which as a fighter aircraft will serve air defense exclusively. Fighters will be fighters again and the unsuitable general designation "combat plane" will be abolished.

The new German Air Force, which with 900 starfighters once was the strongest air force in all of Europe, has after 10 years of operation with Phantoms reached a point, as far as pure air defense is concerned, where it is being totally outmaneuvered. The more modern aircraft of much smaller air forces, as that of the Belgians, are far superior in combat turns to the German version F4F of the American Phantom, despite the slats and other refinements. In maneuvers the condensation trails in the sky are shocking witnesses. The Texas F 16 or the Hawthorne and St. Louis F 18 closely follow the tail of the Phantoms which come from the same plant on the Mississippi, and they follow more rapidly than the planners of Western defenses would like to see.

The Soviets are making preparations to achieve the same operational capabilities on their future MIG models. The Russians can already fire up and down, which is only possible with a clever radar fire control system. More than 70 percent of the Warsaw Pact aircraft are classified as third generation airborne weapons systems. The on-board radars can spot air targets far beyond the visual range at distances of more than hundred kilometers, also from elevated positions and against the ground.

There is no doubt: the tactical air forces of the Warsaw Pact have improved greatly during the past years. With approximately equal numbers of aircraft, the quality of fighter planes, their armament, and their electronics have been considerably improved and their capabilities now match Western standards. Especially the Mikoyan development of a medium heavy tactical fighter plane of the F 18 class clearly illustrates the need for a successor to the Phantom with a strong emphasis of the fighter role.

With the rapid development of technology, fighter aircraft have become so expensive that aircraft costs are calculated in terms of kilogram-aircraft. One kilogram-aircraft of the Fighter 90 type today costs DM 6000. Planners and engineers pretty much agree that such an aircraft can be built below the 10,000 kg limit. This means to the money providers that a single aircraft would cost DM 60 Million. The German Air Force requires two million kilogram-Fighter 90. According to Air Force concepts the Fighter 90 must secure the deployment of the new Tornado weapons system in depth. It must have all-weather battle capability over short and medium guided missile ranges in air defense missions. The Phantom does no longer have this capability.

Additional Air Force requirements are: the Fighter 90 must possess high maneuverability in the range from low subsonic to high supersonic speeds, in altitude from very low to very high altitudes and it must have a great weapons payload as well as high maneuverability for fighter missions. This requires small turning radii, great turning power for rapid changes of direction, great climbing capability at all altitudes, as well as structural strength of the aircraft, rapid acceleration and deceleration capability, a thrust corresponding to take-off weight and exceeding the operational weight, and an efficient ratio of loaded weight to supporting area.

These maneuvering capabilities must clearly exceed the agility of the Phantom, according to the Luftwaffe requirements, and should at least equal the capabilities of existing fighters such as the F 15, F 16, and F 18, in order to remain competitive with Soviet developments during operational deployment.

The Phantom, which was developed with the technology of the fifties and sixties, and in which the over 50-year old astronaut John Young flew climbing time records, should be decommissioned today. The Phantom, with its plump body is an aerodynamic antique, and its smoky engine is technologically outmoded. It is also obsolete with respect to the thrust-to-weight ratio, and the electronics are outdated.

John Young penetrated outer-space five times since the day that he drove the Phantom into the sky in the race against the clock in Point Mugu at the

California coast. He now is preparing to mount the American space vehicle which flies S-curves in the upper atmosphere at a speed of 18,000 km/hr. Time has moved so fast and the Phantom has become so ancient. But the Bonn money supply determines technological progress. Operational readiness of the Fighter 90 cannot be expected before 1993.

What solutions are available to the officers in the Hardthoehe barracks? The palette ranges from purchase of existing fighters on the market (F 16, F 18, Mirage 2000) to modified models (F 16 E, F 18 L) to partial new developments (Integration Program) to completely new developments (N/D 102, ACX, ACA). New developments are offered by partners who have urgent need to satisfy the same mission requirements.

The air force will wait for partners and will have to jump one generation of fighters. Future fighter construction uses a new vocabulary: "Delta Canard configuration, artificial stability, direct power steering, wings-only without elevator units, dry thrust concept, CFK technology."

It is important that Bonn is now beginning to look into the future, so that the condensation trails of a fighter in the middle of the nineties and far into the next century will be on the inside curve in air combat.

7994  
CSO: 3620/414

## ARMENIAN TERRORIST GROUP ASALA ACTIVE IN STOCKHOLM

Stockholm DAGENS NYHETER in Swedish 12 Aug 83 p 3

[Article by Jan Malmberg]

[Text] The Armenian terrorist group ASALA [Armenian Secret Army for the Liberation of Armenia], which according to the Security Police is threatening to kidnap Carola Haggkvist, is making Stockholm one of its most important bases.

That has been reported to DAGENS NYHETER by sources within the National Criminal Police Corps.

It has long been known that Sweden is one of the most common retreats for hunted members of that organization. There are several reasons. For one thing, it is relatively easy to enter Sweden through one of our neighboring Scandinavian countries. For another, Sweden is home to a growing number of Armenians, and they can be expected to protect the terrorists.

ASALA used to operate out of its headquarters in Paris. But since the bomb attack at Orly Airport outside Paris this summer, it has become more difficult for the group to elude the intensified hunt by police.

According to DAGENS NYHETER's sources, it is therefore probable that the men behind the Orly attack are now in Sweden.

It is not known whether the same men are also behind the threat against Carola Haggkvist and the earlier plans to kidnap the king and Minister of Immigration Anita Gradin.

According to SAPO [Security Police], the purpose behind those plans is to obtain the release from prison of the Armenian drug kings Kework Vartanian and George Makhlof.

Carola Haggkvist is being guarded around the clock by personnel from the Security Police. The thousands of fan letters she receives every day will be opened first by the police. Heavier envelopes and packages will also be X-rayed.

On Wednesday evening, when the kidnap threat became known, Carola Haggkvist was in Oslo, where she held a press conference.

When she arrived at Arlanda Airport [in Stockholm] late Wednesday evening, she was taken directly to a secret address.

She is scheduled to appear at the Grona Lund on Saturday. She has no plans to cancel that appearance, according to her recording producer, but special security precautions will be taken during the performance.

#### Top Man Seized

One more man suspected of being a top figure in the so-called Shoemaker Ring has been arrested. He was arrested just before the trial of the gang's international leader, George Makhlof, began.

The fact that he happened to be in Stockholm just before the trial led to suspicions that he might try to take singer Carola Haggkvist hostage in order to secure the ringleader's release.

It was by sheer accident that police were able to seize the man in question in a Stockholm suburb. He had been a fugitive from Swedish justice since February 1982.

He had been charged in absentia with serious narcotics violations, serious assault and battery, and kidnaping. The kidnaping occurred in 1981, when he kidnaped and assaulted an individual. He is regarded by police as very dangerous.

Police are now trying to determine whether his presence in Stockholm just before the narcotics trial was a coincidence. They are not ruling out the possibility that the 49-year-old man was here to try to free a prisoner or carry out a kidnaping.

The kidnap threats against Carola Haggkvist, King Carl Gustaf, Minister of Immigration Anita Gradin, and others may have been part of those plans.

11798  
CSO: 3650/269

prison. Sometimes too, only their bodies are returned. When they are looking for a suspect, they don't go to his home to arrest him. The whole village is assembled in the square and the person in question is called up. They undress him in front of everybody and torture him in public for a while: cigarette burns, dagger cuts and "blowtorch work" along with the breaking of arms and legs are some of the practices currently employed. If the torture victim doesn't die, he is shipped off to prison or death. A technique frequently applied to those who are suspected of being serious opponents is the slow burning of certain members, the throwing of acid in their faces and the bastinado until they die. These *"/exhaustive/ [in italics] interrogations"* take place especially in the barracks and police stations, after which a current practice requires that the body be dumped into the river "to serve as an example."

#### Massacres

In spite of everything, denunciations are very rare. The Turkish soldiers also launch "punch operations" designed to uncover the presumed rebels or underground agents. In so doing they exaggerate the importance of the resistance and get somewhat intoxicated over their own activities!

[Question] What tactics [do they use]?

[Answer] The soldiers arrive and cut off a large village. They assemble the population and make a roll-call. Theoretically each station or regional official has a list of all the inhabitants. During the roll-call the officer stops at certain names. For example, "Seid, Tewfik, Achmed... oh yes, Achmed..." and he lets a moment go by in silence. The person who has been named already knows that he is going to be questioned and the officer tries to sound out the reactions of the party involved and the others who are present. Once the roll-call is over, the interrogation begins with an imaginary denunciation: "Your cousin Abdul, your father-in-law, old Mustapha, have told us that you are hiding a revolver, that you bring food to a bandit on the mountain" and so on. They hope to stimulate reciprocal denunciations. But at the same time the imaginary suspects become real ones for those who invented them. If, by chance, they discover something, the whole village is sometimes massacred. The slightest suspicions induce very violent reactions. Last month elements of a pursuit commando discovered eggshells and ashes from a fire in a mountain pasture. They at once pounced on the nearest village and assembled everyone. All the women were immediately stripped of their clothes, which were confiscated, and several men were soundly beaten and lined up against a wall. The lieutenant announced that the fire proved that the village was supplying outlaws with food and that the women would walk about naked and all the men would be beaten daily until he got the names of the guilty parties. Fortunately, on that occasion they discovered in time that shepherds from a neighboring hamlet, whom the soldiers had checked out the day before, had been in the area.

There is, of course, the official line about protecting the population from bandits and terrorists. But the means of resistance are still so limited and the terrorism of the state itself so omnipresent that no one in Kurdistan can grant such statements the slightest credibility. Only the landowners, who

## INTERVIEW WITH MEMBER OF KURDISH WORKERS PARTY

Brussels LE VIF in French 30 Jun 83 pp 55-57

[Interview with a leader of the Kurdish Workers Party by Gustave Werner, in Athens: "Kurds Denounced"; date not given]

[Text] Pursued in the name of international interests, the Kurds are today waging a desperate war. At a meeting in Athens a leader of the Kurdish Workers Party (PTK) spoke to us.

A member of the PTK: "General Evren's regime wanted to 'settle the Kurdish question' as it had in its eyes settled the social question: by eliminating the Kurds as it had eliminated the labor unions and parties. It had to crush any inclination toward national opposition. And that could arise as a result of any demand, particularly on the part of the peasants. So the existence of an armed combat in Iraqi Kurdistan, waged since 1979 by the Iraqi PDK (Kurdish Democratic Party) and other forces with thousands of well-armed and trained fighters might contaminate the Kurds of Turkey. For the junta an ounce of prevention was better than a pound of cure. At Diyarbakir, the town where the famous prison in which thousands of political prisoners are languishing is located, the socialist mayor, a peaceful and respected man, was deprived of his post in September 1980 and so badly tortured that he is paralyzed and blind. After the event, they released him. There was not a single charge against him.

[Question] What is the Kurds' situation today?

[Answer] Let's say that they are on the edge of survival. One has to concretely imagine what the military occupation is like. Ankara has sent 200,000 men into the region, including several shock troop units. Most of the villages are either constantly occupied or commandeered for the night billeting of troops.

The men are forced to undress and are soundly beaten. Anyone who doesn't scream is "a true Turk"; the others are entitled to a bastinado on the soles of their feet or are exposed to the sun for hours on end. Meanwhile the women are grossly insulted and those who react are stripped naked, sometimes raped, to "show the Kurds what men are really like." At the slightest revolt, they are shipped off to the barracks or police headquarters. Sometimes they come back ruined; sometimes they don't come back because they are on their way to

Radio Moscow commented thus: "ASALA clearly desires the territory of Soviet Armenia. This is an admission that ASALA is a U.S.-directed movement that is not working to add Turkish soil to Soviet Armenia, as they would have one believe, but, on the contrary, that wants Armenian lands from the Soviet Union, using Armenian territory in Turkey as a pretext."

Turkish officials who assess the Armenian Terrorist Movement and ASALA activities state that there are numerous sources behind the incidents. They observed, "Turkey has experienced these types of problems since its founding. We are aware of who the motivating forces are. If one were to focus on a positive note in the recent Soviet broadcasts, it would be that this is the first time Moscow has been so openly critical of ASALA activities and its efforts to establish a new Armenia."

CSO: 3554/406

## TURKS ASSESS RADIO MOSCOW ATTACK ON ASALA

Istanbul HURRIYET in Turkish 8 Aug 83 p 11

[Text] For the first time since the onset of Armenian terrorism and after the deaths of 34 Turkish officials, the Soviet Union has vehemently criticized the terrorist organization ASALA. Moscow asserted that "Western imperialism" lies behind ASALA and scored Armenian terrorist demands for territory on which to establish an "Armenian state."

Experts who evaluated Moscow's position maintain that this reaction stems from ASALA's desire to include Soviet Armenia in this state.

In recent radio broadcasts, Moscow has given extensive coverage to Armenian terrorism and ASALA efforts to establish an Armenian state. Moscow announced that the Soviet Union "agrees that the Armenian massacres took place but that it closed the issue in signing the treaty with the Mustafa Kemal government in 1921." Noting in its broadcasts "Article 15 of the 1921 Treaty," Moscow reported that by this article "the crimes committed on the Caucasus Front" by citizens of Turkey and the Soviet Union were forgiven. Moscow asserted, therefore, that if there are crimes "because of the Armenian massacre, a pardon was issued, the Soviet Union endorsed it in 1921 and has subsequently never re-addressed this issue."

Moscow later stated, "Since the 1921 Treaty, the Soviet Republic of Armenia has never taken a single step to incite feelings of revenge among the Armenian people or to demand territory. The forces exploiting the Armenian massacre to create enmity between Turkey and the Soviet Union and establish an imperialist-directed Armenian state have been those of world imperialism, reactionaries in collusion with it, and chauvenist Armenian reactionism."

Radio Moscow charged that ASALA is a "provocatory organization" masquerading behind the image of "leftist organization, a national liberation movement." It announced that the ASALA program summarized its goal thus: "Following the liberation of Turkish-government territory and with the addition of other Armenian lands, a democratic socialist government will be established..."

generally live in the towns and in any event away from the villages, are safe from this constant grip. Even licensed informers, who exist in every country in the world, are not exempted from the constraints that are imposed and are at the mercy of an absolute arbitrariness. What is involved is something other than a civil war; it is a /war/ [in italics] waged against an entire people, not against their opinions. Normal life is impossible. Let's take the town of Urseli. Like many other towns, the elementary school has not been open for 2 years now. It's used as a barrack. There are no longer any young men in the village. Some are in prison, while others are being sought or are dead. Some emigrated as early as several years ago. The young women of the town are there to take care of the soldiers. That is, to wash and iron their clothes, prepare their meals and even polish their boots. Not counting other, less readily admitted services which can only be obtained through violence. Officially, there is no curfew, but the army is always present and the soldiers are so demanding that after 1900 or 2000 hours everyone shuts himself up in his home. There are often three soldiers for every local resident. One consequence of this policy is a considerable decline in any economic activity, not counting the tax the troops levy on cattle and crops to provide for their needs.

[Question] What is your military strategy?

[Answer] For the time being our strategy consists of withdrawing and concealing ourselves, of organizing and better arming ourselves. Above all we are trying to develop networks of mutual aid, information and care to restore cohesion and motivation to the Kurdish people, whom they persist in depersonalizing, crushing and terrorizing. This is a basic condition for maintaining their existence, one preliminary to any military offensive strategy.

[Question] And your political strategy?

[Answer] Right now, we are fighting for the autonomy of Turkish Kurdistan with the prospect of a reunited and independent Kurdistan later on. This leads us to fight the military dictatorship along with those Turkish political and labor union forces that recognize our national rights and have a socialist view of matters and to act with our Kurdish brothers on the other side of the border, particularly in Iraq. This will not keep us from engaging in contacts with the Kurds of Iran and Syria. We must admit that for years now in different countries they have flaunted the possibilities of national autonomy in the faces of segments of our people. The prospect of this autonomy, even if limited, has seemed immediately concrete, preferable to war. Thus the Iraqi Government, the Shah of Iran's Government and then that of the Khomeyni republic have successively exploited "the other Kurds" to create difficulties for themselves and weaken us. Recently again, despite the massacres perpetrated on Iranian Kurdistan by the "guardians of the revolution," some members of the Iranian PDK showed themselves to be in favor of the Islamic Republic whereas, while his regime has taken it upon itself to liquidate the Kurds of Iraq and the Iraqi democratic parties, Saddam Husayn has provided the Kurdish rebels in Iran with some aid. Aside from the dissension this creates in the Kurdish people's liberation movement, in the end these are sucker's deals. At present

a majority movement is evolving throughout all of Kurdistan to once and for all go beyond these tactics and act in a united fashion. And what is the conviction that is becoming more and more widespread?

Only the reunification of our people within an independent Kurdistan will permit them to live in peace.

[Question] How then do you explain the Turkish Army raid on Iraq?

[Answer] The death sentences meted out to PTK activists at Diyarbakir last May serve as a warning; The junta will go all out. But it was also a matter of hitting the Iraqi PDK rear guard bases to crush any support for the Turkish Kurds as well as to try to liquidate the dissidence in the Iraqi Kurdish movement. Baghdad already has the Iranians on its hands and has not managed to subjugate the PDK, which commands several thousand seasoned and well-armed fighters. Ankara has quite well realized what the dynamics of the Kurdish movement, which are bringing it to unity beyond artificial borders, are and has decided to resolve the problem in its own way. And to pay the price for doing so. We are explicit; we know that hundreds of wounded Turkish soldiers have arrived at hospitals in the border area. Guerrillas have been killed or wounded, but it is especially civilians who have gotten the worst of it. We estimate the number of victims at between 3,000 and 4,000. What has surprised us is the depth of the Turkish attack. They penetrated to almost 80 km inside Iraq. We had planned to disengage. The enemy had concentrated 15,000 men backed by tanks, helicopters and air support. The first pretext — in pursuit of smugglers! — was rapidly abandoned and the Turks tried the raids launched in May by joint units of the Iranian PDK and the Turkish PTK. The heaviest of these raids cost the Turkish Army an officer and three soldiers. Such an offensive cannot be attributed to a simple response. Since the start of 1981, all the border villages of Turkish Kurdistan have been forcibly emptied of all their inhabitants and transformed into a militarized zone. Since then there have been repeated maneuvers, including maneuvers the troops of the U.S. Rapid Deployment Force have participated in. This leads us to speak of two other factors of unequal but complementary importance. The first of these is the fact that the economic and social instability of the military regime encourages expansionist ambitions. As with the invasion of Cyprus in the past, these may serve as a diversion, but also seizure of the oil-bearing regions of Iraqi Kurdistan about the towns of Mosul and Kirkuk would provide Turkey with major aid in time of crisis. The Turkish national charter has claimed these regions for decades. The TIMES (28 May) mentioned this peculiarity: For several months these claims which had been slumbering have been publicly brought to mind in various broadcasts and articles in the Turkish communications media. Curiously, the Saddam Husayn government has not reacted to these declarations which are being made more and more openly. Since 1978 a Turkish-Iranian security agreement has been in effect aimed at the Kurdish movement and which provides authorization for the Turkish Army to penetrate up to 15 km into the interior of Iraq. It was in connection with this that the Iraqi minister of foreign affairs visited Ankara barely a few weeks ago. As far as we are concerned, there is no doubt that it was to settle the terms of the latest offensive.

Iraqi Kurdistan has become a region of vital importance for the Baghdad regime, not only because oil is produced there, but because the oil pipeline and the trade route linking Iraq and Turkey go through it. Now due to the Iranian-Iraqi war, the Persian Gulf is closed to */all Iraqi oil production/*. It must, therefore, cross regions largely liberated by guerrilla forces composed essentially of the Iraqi PDK, but also various Iraqi leftist forces outlawed by Saddam Husayn for 5 years now. On three occasions raids on the oil pipeline have been crowned with success. The Iraqis are incapable of responding to this situation and, to save their regime, are forced to close their eyes to the ambitions of the Turks, thus in fact permitting Ankara to gradually ensconce itself in the region it covets.

It is U.S. policy which we directly challenge. The whole system of Western security in the Middle East used to hinge on the Iranian Army. Since the downfall of the shah, the United States has felt that NATO's southern flank is exposed, that the instability of the region makes it uncontrollable and that it must without delay regain control of the situation. This role of resumption of control, which certain strategists thought it best to assign to Saudi Arabia, seems to have fallen to Turkey.

A Turkish-American plan for control of the whole region, hinging (essentially) on the Turkish Army, does exist. The geographic core of this "locking" device is precisely the mountain mass of Kurdistan. In the top echelons of American imperialism the Kurdish people's liberation movement is considered to be a destabilization factor and in any event they have no intention of placing an obstacle in the path of the initiatives of their Turkish ally, the key to the whole "defense" system of this region.

[Question] Do you have any concrete evidence to back up these assertions?

[Answer] This is the first time the American commanding general of NATO headquarters has visited the area in person. Then there is the current transfer of */10/* Turkish military airports -- to Turkish Kurdistan. Then too, the possibility that they may occupy the area.

From there it would be possible to intervene in the Persian Gulf or the Near East if necessary. Despite a "thaw" in American-Iranian relations, the Iranian Army is not a reliable instrument. Therefore, the role of the Turkish Army remains an essential one for the United States.

11,466  
CSO: 3519/567

## REFINERY STOPPAGES FOSTER FUEL IMPORTS

Nicosia I SIMERINI in Greek 1 Aug 83 pp 1, 12

[Text] "The refinery is practically shut down," a representative for a petroleum products company stressed to the I SIMERINI, and he added that: "For about a year now, the refinery has not been in a position to meet the needs of the Cypriot market for petroleum products, with the result that from time to time we are seeing a shortage of many petroleum by-products."

Also the same representative stated that:

The fact that the operation of the refinery is uncertain compels the petroleum-products companies to import refined petroleum products from abroad in order to meet their needs. As is known, for the importing of refined petroleum products a special permit from the Ministry of Commerce and Industry is required. Formerly this ministry gave permits for such imports only in exceptional cases, and specifically when a shortage was seen because of maintenance work being done on the refinery. This could happen only once a year. During the last year, however, the importing of refined petroleum products has become a constant phenomenon.

#### Imports Are Cheaper

According to the same information received by I SIMERINI, the costs for imported refined petroleum products are less than for petroleum products which are refined at our own refinery.

Specifically, the price for imported refined "super" gasoline, after adding the other outlays of the companies (customs commissions of gas-station operators and allowable profits to the companies), should be 1,025 mils per gallon to the consumer. But it is being marketed at the price of 1,500 mils per gallon, as if it were a question of "super" gasoline refined in our own refinery.

These particulars are familiar to the ministry, which is avoiding making recommendations to the companies so that they can revise their prices downward when they import refined petroleum products.

Meanwhile all reports received by I SIMERINI state that the ministry is now studying the possibility of repairing the already shut-down refinery, using the pretext that the appropriation which will be spent for this purpose "is being made available for the further expansion of the refinery, so that it will be able to meet the increased needs of the Cypriot market for petroleum products."

## BRIEFS

OIL PRODUCTS CONSUMPTION DROPS--Total domestic sales of petroleum products--minus sales to electricity and gas works--dropped by 2 percent in April, compared to the same month last year. Fuel oil sales rose slightly, but sales of heavy fuel oil and gasoline dropped by 7 and 10 percent, respectively. Electricity consumption in April of this year was 5 percent higher than last year, according to Danmarks Statistik. [Text] [Copenhagen BERLINGSKE TIDENDE in Danish 4 Aug 83 Sect II p 2] 9336

CSO: 3613/170

## HIGHER OIL PRICES INCREASING INTEREST IN HYDROELECTRIC POWER

Oslo AFTENPOSTEN in Norwegian 25 Jul 83 p 5

[Article by Eivind Fossheim: "Power Development in North Trondelag: High Oil Prices Have Increased Electricity Consumption"]

[Excerpt] Mosvik, July. "The increased oil prices have caused stronger demand for electric power both in industry and in the heating of private housing. While we can deliver electricity for 25 ore per Kwh, the oil prices today correspond to almost 40 ore per Kwh," Lars Juul of the Nord Trondelag Electric Power Plant tells AFTENPOSTEN.

"But now the thing is to build power plants like we are doing in Mosvik, which with relatively large storehouses can practically store all summer power for winter use. The fact is that winter power amounts to 70 percent of the increase in the regular supply," says Juul.

"We definitely produce cheap electricity today. The loans on the old power plants have been paid off long ago and when the consumption levels off, we will have a stupendous economic position. But current increases in consumption counteract such favorable development. Large investments are needed for new projects and here we sit with short-term loans and high interest rates," Juul points out.

"Moreover, compensations for the waterfall rights have not risen in step with the cost development; neither has the care of landscaping nor any other consideration of nature and environment been any extra economic burden. On the other hand, industrial discharge has been, which is strongly affected by the oil trade and obviously the introduction of the work environment law which lead to a 13 percent jump," says Juul. The majority of the total development costs, however, continue to lie in mountain, concrete and soil work, but thanks to the fact that Norwegian contractors are at the top with regard to advanced techniques, the tunnel costs have not risen as rapidly as expected either.

Whole section drilling has been made through where the tunnels are long enough to make this procedure economical, and by using in Mosvik a whole section drill of a diameter of 3.5 meters and 500 tons of feeding power, tunnels are cleared out with a speed of up to 215 meters a week or 140 meters a section," says Juul.

The site engineer at Mosvik Power Plant, Odd Welle, who was also responsible for the Abjora project, says that the construction of power plants continues to be a tough and hazardous job. "With the limited time allowed from the time the concession is given until the time the power plant is to be operational, it can be very hectic, and strict demands are set to employ experienced construction workers who know their job and have learned the routines of security previously. Piecework requires people who are up to standard and if not, they are quickly frozen out," says Welle.

When talking about job possibilities for a region where power plant construction will be undertaken, one must realize that for the tunnel work itself and much of the operation in general, the need is for experienced people who have worked in plant construction before, while the local contractors and their people enter the picture more strongly when it comes to transport of cargo and the building of roads in connection with the project.

Chief Engineer Juul underscores that it is very important that a report of the development plans immediately call forth the expression of opinion which means that as soon as possible the interests of those concerned can be considered. Thereby the developers will gain better understanding of the necessity to soften some measures, and at the same time, the locally interested parties can more easily familiarize themselves with the developers' problems and better understand them.

9583  
CSO: 3639/149

## STATOIL DIRECTOR: REQUESTS TO DRILL ABROAD WERE REFUSED

Oslo AFTENPOSTEN in Norwegian 11 Aug 83 p 27

[Article by Brit Myhrvold: "Arve Johnsen on Oil Exploration in Other Countries: 'Work Prohibition' for Statoil"]

[Text] Verdal, 10 August. "I call it 'work prohibition' that during recent years Statoil has been directly prohibited from investing in oil exploration and development in other countries. The internationalization of Statoil will be a powerful lever for Norwegian industry and a possible door opener for Norwegian business abroad," said Statoil's director Arve Johnsen at a press conference in Verdal on Wednesday.

The prohibition against Statoil establishing itself abroad was approved by the Storting in connection with the investigation of Statoil's future. The proposal of the Mellbye committee is now in hearings.

Statoil is supported on this question by both the National Association of Machine Shops and the Norwegian Association of Industry. The issue was taken up at a meeting between Statoil and the industry association one week ago. Minister of Oil and Energy Kare Kristiansen told AFTENPOSTEN that the question must be seen in connection with the Mellbye committee's proposal, and that considerations of Norwegian industry must weigh heavily. To the extent that one agrees that Statoil should be an oil company the same as others, it would be natural that the company should establish itself abroad. Internationalization of Statoil will immediately become more difficult if it is decided that Statoil will continue to have important administrative tasks for the Norwegian state, said Kristiansen.

Arve Johnsen said that Statoil has received inquiries from countries in Europe, the Far East and Africa on this. Participation in foreign oil activity did not start before the end of the 70's.

"We must learn to crawl before we can walk. Now we can both walk and run in exploration. We can gradually also plan and expand ourselves," said Arve Johnsen.

## BRIEFS

INCREASED GOTLAND OIL PRODUCTION--Four out of seven wells have produced oil on GOTLAND. A total of 7,055 cubic meters of oil have been extracted this year, and the oil production now pays the total expense of the exploration, according to Opab. The proceeds of the oil are 2.9 million kronor. [Text] [Stockholm DAGENS NYHETER in Swedish 22 Jul 83 p 6] 9843.

CSO: 3650/253

## STUDY COMPARES BUSINESS PERFORMANCE IN NORDIC COUNTRIES

Stockholm DAGENS NYHETER in Swedish 11 Aug 83 p 13

[Text] Scandinavia's largest firms are in Sweden, the most profitable are in Norway, and the most solvent are in Denmark. Finnish firms, on the other hand, have fallen behind, reporting a collapse in profits and declining profitability.

This is shown by the magazine VECKANS AFFARER's survey of big Nordic firms. The survey covers a total of 732 firms with sales last year of 1,461 billion kronor.

The best performers last year were the Swedish firms, which reported a total increase in profits of 18 percent. In Denmark, profits were up by 4 percent, while in Finland they dropped a full 63 percent, and in Norway they stood still.

If the countries are ranked according to profitability, Norway is clearly in first place, while Denmark is second, Sweden third, and Finland fourth.

Yield on total capital amounted to 14.7 percent in Norway. But if the Norwegian oil companies are excluded, profitability drops to only 7.6 percent, or just above the average for the big Finnish firms.

Only in Sweden and Denmark did profitability increase somewhat (up by between 0.1 and 8.1 percent in Sweden and between 0.5 and 9.5 percent in Denmark).

The three largest firms in Scandinavia are Swedish. Volvo heads the list with sales of just over 75 billion kronor, followed by Electrolux (32 billion) and the ASEA [Swedish General Electric Corporation] (26 billion).

Neste, the Finnish state-owned oil company, is only in fourth place. Fifth place is held by a Swedish retailer, the KF [Consumers' Cooperative Union], which in 1981 was the third largest firm in Scandinavia.

On the other hand, Scandinavia's biggest employer is Electrolux, with about 100,000 employees, followed by Sweden's Volvo, Ericsson and ASEA groups and its government-run Postal Administration.

Danish firms are clearly the most solvent. The leaders are the Fisker and Nielsen vacuum cleaner firm and the Spies travel bureau, whose solvency rates are a full 77 percent and 69 percent respectively.

## BALCI URGES TURKISH-CYPRIOI INITIATIVE IN ECONOMICS

Istanbul CUMHURIYET in Turkish 9 Jun 83 p 3

[Article by Ergun Balci]

[Text] In the case of declaring an independent Turkish Cypriot state, one of the most controversial topics is, not that such an enterprise could be achieved immediately as officials here frequently stress, but the economic results that would develop. In fact, the economic aspect of the question interests the man-on-the-street more than the political aspect. This is because the Turkish Cypriot community is tied to the Greek Cypriots in the south of the island from the standpoint of water and electricity. There is no doubt that officials here are also dwelling on economic problems. During a conversation with reporters, Turkish Cypriot Federated State Chairman Mustafa Cagatay mentioned this subject and said that, in an emergency, "bringing water from Turkey can be considered." Cagatay, however, added that this is not a new idea, that it has been discussed since the 1960's. Cagatay, noting that electricity could be a problem in the beginning, said, "We remained tied to the Greek Cypriots on the electricity issue in order to demonstrate that we were not separatists. We did not establish our own electricity system. If necessary, however, we will set up a separate system with international and Turkish aid and solve this problem."

One of the topics that is being debated when emphasizing the economic results that would follow declaration of independence is the difference in economic development between the Turkish Cypriot and Greek Cypriot regions. This difference can be clearly seen in per-capita income. Average annual income in the Greek Cypriot community approaches \$6,000. In the Turkish Cypriot community, it falls between \$1,300 and \$2,000.

The administration reports that the large amount of assistance given to the Greek Cypriots and the economic embargo applied against the Turkish Cypriots play an important role in this. Cagatay says, "The Greek Cypriots received aid in the neighborhood of \$40 million from various international organizations, of which \$10 million comes from Greece."

The opposition, while admitting that the administration agrees to the validity of this view, stresses that it is not correct to place the blame for the ruination of the economic situation in the Turkish Cypriot region completely outside the region.

For example, Republican Turkish Party Chairman Ozker Ozgur does not concur with the belief that Greek Cypriot obstacles have struck a fatal blow to the Turkish Cypriot sector's exportation. Ozgur defends the need to look internally for the roots of the economic problems. The Republican Turkish Party chairman points out that Turkey meets 60 percent of the Turkish Cypriot Federated State budget and states, "If Turkey, with a population of 50 million, cannot raise the economic level of 150,000 persons, it is necessary to find the reasons for this. We cannot lay the blame entirely on the Greek Cypriots."

Very well, who is essentially responsible for this situation?

Ozgur says, "A trade bourgeoisie that does not make investments and that does not produce has been created here. How can you expect economic development from a community that does not invest and does not produce?" He adds:

"You can find every sort of foreign goods here. Now, think about this. I, as a merchant, collect foreign exchange in Europe using Turkish currency. Then, I bring in goods here from abroad using that foreign exchange. I will sell them here for Turkish currency and deposit the money I make in banks in Switzerland or London. In other words, there is no investment, no production. How can you expect economic development under such a system? Development is impossible through suitcase tourism. As long as the bourgeoisie does not perform the duty that falls on it, it cannot be correct for us to look outside for the source of all problems."

It is impossible not to agree with Ozgur. If the bourgeoisie does not make investments and does not produce, the level of economic development of that community will, without a doubt, be low.

However, it is imperative that the bourgeoisie pass through a period of experimentation in order to learn about being the bourgeoisie. Yet, the trial period for the bourgeoisie of Cyprus has been so short, it only goes back to 1974. Prior to that, the Greek Cypriots did everything they could to sabotage the Turkish Cypriots' enterprises. Investments and production were monopolized by the Greek Cypriots. The Greek Cypriots established hotels, opened restaurants. The Turkish Cypriots came in as waiters and receptionists. The Greek Cypriots established tourism corporations and brought in tourists. The Turkish Cypriots were chauffeurs and showed the tourists around. When going from Nicosia to Kyrenia, Information Office Director Oktay Oksuzoglu pointed out a number of houses of Turkish Cypriots that had to be built using sun-dried bricks because the Greek Cypriots would not give permission for the consignment of cement.

When the Turkish Cypriots, who were pushed into second place in the economic field and who were abandoned to the service sector, began to fight for their lives and to stand guard with arms day and night, they remained totally outside investment and production activities.

It was natural that, with the opportunities that emerged following 1974, a faltering would be experienced due to a lack of experience.

We, however, sincerely believe that the Turkish Cypriots will be able to overcome this confusion. The Turkish Cypriot community is a community that fought, for years, an enemy that was much more powerful than itself in terms of both numbers

and arms. It gave a great deal of importance to discipline, organization, and creativity in order to be able to close the gap between itself and the Greek Cypriots.

Time alone is necessary for our Turkish Cypriot brothers to focus the discipline and dynamism used for fighting for many years toward the economic field.

And that period of time will not last long.

11673

CSO: 3554/323

## CORRECT PLANNING NEEDED FOR RELATIONS WITH EEC

Nicosia O FILELEVTHEROS in Greek 31 Jul 83 pp 1, 12

[Text] "With the admission of the United Kingdom and Greece into the EEC and the expected admission of Spain and Portugal in 2 or 3 years, the prospects for promoting Cypriot agricultural products are deteriorating. And this is because the Community will become almost self-sufficient. The argument that Cyprus is a small country and that the volumes exported are too small to disturb the equilibrium levels of a large foreign market is rather too reckless to be espoused."

This is the finding arrived at in the last issue of the Economic Bulletin of the Popular Bank, which goes on to explain:

"For the Community, it is mostly a question of principle to give priority to imports from countries which are applicants for admission.

"Quite recently the EEC gave certain concessions to Cyprus. Specifically, the quantity of grapes going to the Community is being increased somewhat, while at the same time the stipulation that Cyprus can export 120,000 tons of potatoes solely to the British market ceases to be in effect, and thus Cyprus acquires the right to distribute this quantity also to other European countries.

"Consequently it is clear that a customs union between Cyprus and the Community is the best of all the alternative solutions. For this purpose a special committee or unit should be appointed which can concern itself with and systematically handle all the ramifications of this problem.

"The chief objectives of such a committee for studying EEC issues will be to conduct research on determining ways and means for strengthening the economic ties between the Community and Cyprus. This research can be focused, among other things, on new varieties of agricultural products and improved methods for producing early-season products.

"Despite the favorable tariff régime for Cypriot industrial products which are exported to the EEC, as was referred to previously, their share in the total of aggregate exports of such products has been just 20 percent, whereas

the corresponding figure for those products which are exported to the Arab countries has ranged between 65 and 70 percent. And moreover, despite the fact that a quantitative restriction has been set by the United Kingdom on articles of clothing which can be exported, significant possibilities in this direction still remain. What is more, the reasons for the drop in exports which was seen in the past, as in the case of wines and leather goods, should be attributed more to an inadequate marketing policy than to a lack of prospects.

"A part of the blame for the unsatisfactory utilization of the prospects for exports of industrial goods to the EEC tends also to be shared by the Cypriot producers and exporters. They have not yet fully evaluated the challenge of exporting to a market which can be hard to please, but which offers tremendous opportunities. It is for this reason that research ought to turn towards the quality of the products, no matter whether these will be exported to the Community or to another market. An accommodation to the preferences of the foreign importer and a continued improvement in the quality of the products are the necessary conditions for strengthening the economic ties between Cyprus and the other countries.

"The policy of close economic relations with the Community can easily be coupled to an effort to strengthen the existing ties with other economic areas as well, such as the Arab area and that of East Europe. This policy could include also an assessment of the opportunities offered by other markets where Cypriot products have not been promoted on a large scale, such as the Scandinavian countries, Africa, the United States, Japan, and others.

"The need to diversify the geographical orientation of the exports of a product to more countries than one has become imperative, following certain painful experiences in the recent past."

12114

CSO: 3521/410

## INDUSTRIAL RECOVERY NOW FULLY UNDERWAY

Copenhagen BERLINGSKE TIDENDE in Danish 4 Aug 83 Sect III p 4

[Article by Erik Bendt Rasmussen]

[Text] The Financial Institute for Industry and Trade (FI) has found growing optimism in business and a marked improvement in the position of many companies. The institute has published figures from 333 companies with rising profits. In addition, FI sees as an optimistic sign the fact that there has been a sharp increase in borrowing.

In its report on the first 6 months of 1983, FI states that the economic situation is looking up abroad and here at home there have been perceptible improvements in conditions for businesses in the form of lower wage increases and falling interest rates.

There also is no doubt that industry and the trades now are looking to the future with greater optimism than they have in a long time, according to FI, whose director is Olav Grue and whose chairman of the board is administrative director H. Bruniche-Olsen of De Danske Sukkerfabrikker.

## Broad Optimism

There were 370 borrowers during the first half of 1982. In the first half of 1983 the figure rose to 607. During the first 6 months of 1982 loans totaled 840 million kroner, compared to 1.066 billion kroner during the first half of 1983. In its 6-month report, FI states that it is noteworthy that the amount of money borrowed increased by just over 25 percent, while the number of loans increased by about 50 percent and the number of borrowers rose by about two thirds, compared to last year. FI infers from this that the optimism is widespread, but for now money is being borrowed primarily for more short-term investment plans.

The FI loans of just over 1 billion kroner were made in conjunction with business investments totalling 2.2 billion kroner, including 1.7 billion for machinery, 403 million kroner for construction, and the rest for product development and marketing, etc.

## Indicator Of The Future

Every year in November FI publishes an analysis of the previous year's activities of companies that have borrowed money. A preliminary analysis already is available, based on the accounts of 333 companies, including 5 percent of the industrial companies and over 10 percent of Danish industry from an employment and sales standpoint. In its comments on the analysis, FI stated that this sampling probably reveals results that are somewhat better than those for industry as a whole. Nevertheless, it probably can serve as an indicator of the industrial situation before the upswing that now has begun in the United States and gradually is occurring in Europe. The 333 companies increased their sales by 17 percent in 1982, compared to 10 percent the previous year. Increased sales in 1982 were just as great on the domestic market as abroad, while in 1981 domestic sales increased by only 1 percent, compared to a 22-percent increase in exports. In terms of quantity, 1982 sales increased by 7 percent, after stagnating the previous year.

## Placed In Reserve

Eighteen percent of the profits were used to pay dividends, while 30 percent went in taxes. But 52 percent of the profits were held in reserve by the companies. Thus, net capital increased from 29.5 percent of the total balance in 1981 to 30 percent in 1982. There also was a modest improvement in 1981 (0.3 percent). Thus, according to FI, for the first time in many years there are some indications that the significant drop in net capital now has stopped and the situation has improved somewhat.

(Million kroner)	1980	1981	1982
Total sales	17,795	19,515	22,865
Consumption of goods	9,159	10,190	12,177
Value increment	8,636	9,325	10,688
Wage costs	4,627	4,840	5,465
Other costs	2,415	2,685	3,061
Write-offs	561	643	720
Interest payments, net	444	483	553
Profits	589	674	889

This chart from FI's 6-month report shows increasing sales and profits by 333 companies.

9336  
CSO: 3613/170

## INVESTMENT IN INDUSTRY IS RAPIDLY INCREASING

Copenhagen BERLINGSKE TIDENDE in Danish 23 Jul 83 p 1

[Article by Frank Dahlgaard]

[Text] The boom in industrial investments is already in full swing.

This is according to Danish Statistics' new "business barometer" which is based on information supplied by leaders of 600 of Denmark's largest industries.

Danish Statistics now show that there was a distant growth in industrial investments in the second quarter of this year and that this growth is expected to continue in the third quarter, even at a somewhat higher tempo.

At the same time, businesses have made a marked upward adjustment in future investment plans.

The Industry Council's chief economist, Jorgen Hansen, told BERLINGSKE that there is now talk about the strongest positive adjustment in investment plans in more than 5 years.

He added that the proven growth in new investments last spring was the strongest since 1979.

Economic indicators show that industry expects the last few months' marked increase in new orders to continue. At the same time, industry expects no change in production and employment from the second to the third quarter.

Danish Statistics say that production as well as employment showed a greater improvement than expected during the first 6 months of this year.

Recent reports that the investment boom has already begun coincide nicely with a study made by the Industry Council, presented 3 weeks ago.

The Industry Council's study is based on information submitted by a total of 1,400 firms--considerably more than Danish Statistics' "business barometer." The study shows that a majority of the firms have adjusted their investment plans in a positive direction since the beginning of the year.

There has been an upward adjustment in industrial investment plans, particularly with respect to investments in product development and machines, while the adjustment in more extensive construction plans has been less.

Chief Economist Jorgen Hansen: "The most extensive investment plans today can be found particularly among smaller and medium-sized industries."

It remains an open question as to what extent the latest political unrest at Christiansborg has slowed the desire to invest in industry.

9852

CSO: 3613/158

## COMPETITION IN FISHERIES RESPONSIBLE FOR FAEROES TRADE LOSS

Copenhagen BERLINGSKE TIDENDE in Danish 25 Jul 83 Sect III p 2

[Text] The Faeroes trade deficit rose by 84,500,000 kroner in 1982 to 424,700,000 kroner, which represents an increase of 25 percent, according to the recently published Faeroes Yearbook for 1982. The yearbook, which contains statistics on almost all matters pertaining to the islands and describes political and administrative affairs, has been compiled jointly by the Faeroese government and the Central Government Supervisor's Office.

Except for 1977, when there was a relative improvement in the trade balance compared to previous years, the deficit has been growing since 1975 due to reduced trade, a decline in the volume of export and a steady increase in import.

Fish and fish products constitute the major share of Faeroese export and, in 1982, these products accounted for 98 percent of the islands' total export.

Faeroese fishermen have traditionally caught most of their fish in distant North-Atlantic waters, in the vicinity of Greenland, Canada and Northern Norway, for example, and the ever tougher international struggle over steadily declining fishing quotas has hit Faeroese fishing hard.

The Faeroes have been limited more and more to their own nearby waters. Hence, the amount of fish caught in nearby waters rose from 14 percent in 1975 to 45 percent in 1982, while the total catch declined from more than 285,000 tons to barely 246,000 tons, which is a decrease of almost 14 percent.

8952

CSO: 3613/158

## RESEARCH GROUP PREDICTS 1983-1984 UNEMPLOYMENT, TRADE FIGURES

Paris LES ECHOS in French 16 Jun 83 p 4

[Article by Pierre Locardel]

[Text] Created as a result of an agreement adopted between the state and the National Foundation of Political Sciences, headed by professor and former minister Jean-Marcel Jeanneney, the Survey of Economic Conditions has just published for the first time its own projection figures.

The results cited by this organization seem tainted by a certain optimism--a relative optimism, nevertheless--to the extent that they are based on a moderate recovery in the West and, even more, on an average dollar exchange rate of 7.20 francs in 1983.

With a 0.1 percent growth in the GDP this year, compared to 1982, the OFCE [French Survey of Economic Trends] projects an overall stagnation but not a recession of the French economy. Next year, however, a slight improvement with a 1.3 percent increase is likely.

This outlook is not preposterous but could be nonetheless somewhat unrealistic, considering the strong downswing currently affecting economic trends. Nevertheless, it definitely sketches the profile of the coming months and confirms that the French economy is rather abruptly entering into a recession. A development that was provoked, moreover, and that is right in line with the Mauroy-Delors plan designed to slow consumption, imports and the foreign trade deficit.

The survey experts, however, (after a rise of 3.3 percent in 1982) are not counting on absolute stability in household consumption, in spite of a current drop in buying power, a drop which is linked to a slower rise in the SMIC (Inter-occupational Minimum Growth Wage) and social benefits, to the increase in social payments, to the tax bite and to control of wages. Consumption should increase slightly this year (+0.7 percent) and a little more in 1984 (1.1 percent), and that thanks to the probable continuation of the reduction in the rate of savings, considered to be a corollary to diminished buying power.

Along the same line, it is unlikely that government consumption will be very dynamic (+1.3 percent in 1983 and +0.2 percent next year), as a large part of the operating budgets must be maintained in nominal terms.

Investment, of course, would be affected by the dip in activity, with an overall drop of 2.7 percent in 1983 and 0.2 percent in 1984. And a new, considerable drop for housing (-4.2 percent and -3.2 percent, respectively) as well as for corporations and private enterprise (-2.5 percent but +0.5 percent in 1984).

Of all these activities, the most favorable effect would involve foreign trade. The gains in productivity obtained through the three devaluations should enable us to attract some portions of the market. Our exports of manufactured goods would grow in volume by 1.4 percent in 1983 and by 2.8 percent in 1984 in the face of a worldwide demand at first declining by 1 percent and then rising by 1 percent. The deficit in our trade balance, thanks also to lowered imports (-2.5 percent this year, +1.7 percent in 1984), would drop to 60 billion francs for the current fiscal year and to 40 billion for the following fiscal year. Rebalancing, as one can see, requires time.

As for prices, their slow-down will probably be less rapid than government authorities predict: -9.5 percent (in a gradual decline) this year and 7 percent the following year.

#### New Outbreak of Unemployment

From these developments, the negative counterpart is the weight which will be exerted on the employment market. Contrary to most economic forecasting organizations, however, the OFCE predicts a moderate rise in unemployment: 70,000 more job applicants this year; +115,000 in 1984. It estimates that solidarity contracts, expansion of early retirement and professional training of youth have not exhausted all their effects and are still going to enable a curb in the growth of manpower supply.

On that point, it remains to be seen who is right. But it is to be feared that this "social treatment" of unemployment cannot hold up for very long, especially during a recessionary period, a basic phenomenon from which all industrial nations are suffering.

Another interesting attempt: the OFCE has endeavored to establish the quantified balance sheet of economic policies applied since May 1981. It shows that the government has taken many risks for meager results.

The government's initiatives--budget deficit, rise in social benefits, devaluation of the franc, etc.--stimulated growth on a yearly average by 0.4 points in 1981 and 0.7 points in 1982. The austerity plan of last March completely cancels the expansionist effects of previous policies. The inflationary impact of those policies was on the order of 0.7 percent in 1981, 2.3 percent last year and 2.6 percent this year. The increase in the foreign deficit in

1982, 40 billion, resulted half from those policies and half from worldwide deflation and the rise of the dollar in relation to the ECU.

Undoubtedly, the Mauroy-Delors strategy has curbed the soaring unemployment. However, between the end of 1980 and the end of 1982, the number of job applicants increased all the same by some 470,000.

12415

CSO: 3519/551

## BRIEFS

NEW FOREIGN LOAN TAKEN--An agreement has been signed in New York on a loan of 15 million dollars to the Icelandic Government, an amount equivalent to 415 million Icelandic kronur. This has been announced in a Ministry of Finance news release. The loan is in the form of a credit note issue and the note has been sold directly to several retirement and pension funds in the United States. The period of the loan is just under 10 years and there are no installments for the first five years. Interest is an average of 12.85 percent. The proceeds of the loan will be for public activities in accord with the current budget. Minister of Finance Albert Gudmundsson said in an interview with MORGUNBLADID that the loan money was not needed for any specific purposes. Instead it would be used for general expenditures and in connection with the old budget and thus not in fact in terms of the plans of the present government. The loan agreement was signed by Sigurgeir Jonsson, deputy bank director of the Icelandic Central Bank. The Icelandic Central Bank made the preparations for the loan. [Text] [Reykjavik MORGUNBLADID in Icelandic 21 Jul 83 p 2] 9857

CSO: 3626/48

## UNEMPLOYMENT, UNDEREMPLOYMENT IN SOUTH EXAMINED

Rome RASSEGNA SINDACALE in Italian 20 May, 3 Jun 83

[Article by Antonio Franceschini]

[20 May 83 pp 25-26]

[Text] As part of an employment problem which is growing worse and worse, the phenomenon of unemployment/underemployment is becoming, especially in the south, an aspect to be analyzed in depth, both in terms of the phenomenon's relevance and its underlying problems. We begin in this survey to describe some of its features.

Some headlines of daily newspapers--"The Bluff of the Unemployed" (REPUBBLICA), "The Real Unemployed Number 300,000" (IL GIORNO) and in response, "How I Scratch Off for You the Unemployed" (L'UNITA)--are certainly indicative, to say the least, of the complexity of the phenomenon of unemployment. This complexity takes on special connotations, as well as vaster dimensions, in the south, where it is necessary to speak of varied patterns of unemployment/underemployment.

Based on quantitative data, of total unemployment the percentage of unemployed persons in the south has not changed substantially in the last 2 years: 45.7 percent in 1981 and 45.5 percent in 1982, although in absolute terms an increase of 66,000 persons (cf. Table 1) has been recorded. Such an increase has taken place, above all, at the expense of men (+52,000); women constitute 51.7 percent of all unemployed persons in the south. The unemployment rates for both men and women, constantly rising in the last 2 years (cf. Table 2), showed a further increase in 1982 over 1981; women in the south turned out to be the most disadvantaged at the national level: in fact, the unemployment rate is 21.92 percent in comparison to 12.06 percent in the central-northern part of the country and 14.91 percent for Italy as a whole in 1982. The official unemployment rate for both sexes is 13.0 percent (cf. Table 1).

If we consider explicit underemployment (people of working age not belonging to the labor force and who have said they are prepared to engage in work activities under certain conditions), the extent of unemployment/underemployment in 1982 amounted to 1,265,000 persons (cf. Table 1), thus the

unemployment rate for both sexes would come to 16.7 percent, whereas that of women alone would be equivalent to 30 percent. It should be noted, however, that the segment of explicit underemployment declined by 26,000 persons with respect to 1981; the most notable drop was in the case of women (-15,000 persons), although the group of people without any possibility of or interest in seeking work (+161,000 persons, of whom 97,000 are women) grew considerably from 1981 to 1982. If in addition to this data, in the case of women, we consider the fact that the increase in women explicitly entering the job market has been rather modest (+25,000 persons), it may be said that in 1982 the process of women explicitly entering the southern labor market seems to have slowed somewhat. Based on an examination of the data, this phenomenon of underemployment involves men as well.

With regard to persons seeking their first job, if 60.85 percent of men and 52.78 percent of women seeking work fall into this category in Italy in 1982, in the south this percentage comes to 63.29 percent in the case of men and 51.33 percent in the case of women. The problems of the southern youth labor market appear to have worsened further as a result of the trend of employment broken down according to age and sex (cf. Table 3), with particular reference to the youngest members of both sexes and young women under the age of 25. In the age bracket of 40 to 59 as well, for both men and women, there has been some decline in employment. The percentage of the labor force at the level of secondary/advanced education is also less than what would normally be expected; of 942,000 unemployed degree-holders and professionals, they number 313,000, however the percentage incidence of this figure is greater than the national percentage (33.22 percent for the south and 32.4 percent for Italy). Women constitute 56.54 percent of this type of unemployment.

The features of unemployment/underemployment outlined above are interrelated to the trend of explicit employment, especially with respect to its internal composition according to industry, sector and professional category. Overall, based on the fact that southern employment constituted (in 1982) 30.5 percent of total employment (cf. Table 4), its internal composition according to major branches of economic activity is interrelated as follows: 20.9 percent employed in agriculture, 26.9 percent in industry and 52.03 percent in the tertiary sector. With regard to national employment trends, southern workers represent 52.1 percent of those employed in agriculture, 22.4 percent of those in industry and 31.2 percent of those in the tertiary sector (cf. Table 4).

Comparing the distribution of southern employment with that of other geographic areas, there are two characteristics peculiar to this area: the high presence of agricultural workers (in the other two areas, they actually represent 8.3 percent of employed persons in the north and 8.7 percent in central Italy) and the low presence of industrial workers. In other words, the existing imbalance in this sector between the south and Italy as a whole is accentuated, if we consider the fact that in the case of dependent employment, the agricultural day laborers in the south represent more than two-thirds of all Italian day laborers. This fact is also related to the trends of various industrial sectors.

Table 1. Population of South According to Sex, and Condition in the years 1981 and 1982

(annual averages of quarterly surveys--thousands of persons)

Tab. 1 - Popolazione nel Mezzogiorno secondo il sesso e la condizione negli anni 1981 e 1982 (medie annue delle rilevazioni trimestrali - migliaia di unità)

	1981			1982			1982/1981		
	M	F	MF	M	F	MF	M	F	MF
1. Forze di lavoro	4.991	2.195	7.186	5.045	2.220	7.265	+54	+25	+79
1.1. Occupati	4.588	1.722	6.310	4.590	1.733	6.323	+2	+11	+13
1.1.1. che hanno dichiarato di essere occupati	4.458	1.602	6.060	4.459	1.622	6.081	+1	+20	+21
1.1.2. che non hanno dichiarato di essere occupati, ma hanno svolto ore di lavoro nella settimana di riferimento	131	120	250	131	111	242	—	—9	—8
1.2. Persone in cerca di occupazione	403	473	876	455	487	942	+52	+14	+66
1.2.1. disoccupati già occupati	60	32	92	78	41	119	+18	+9	+27
1.2.2. in cerca di prima occupazione	242	228	470	288	250	538	+46	+22	—68
1.2.3. che hanno dichiarato di essere in condizione non professionale, ma sono risultati in cerca di lavoro	101	214	315	88	196	285	—13	—18	—30
2. Persone non appartenenti alle forze di lavoro	4.787	8.009	12.796	4.806	8.044	12.850	+19	+35	+54
2.1. In età lavorativa (14-70 anni)	1.785	4.907	6.692	1.837	4.991	6.828	+52	+84	+136
2.1.1. disposte a svolgere attività lavorativa a particolari condizioni	94	255	349	83	240	323	—11	—15	—26
2.1.2. senza possibilità o interesse a cercare lavoro	1.691	4.653	6.344	1.754	4.750	6.505	+63	+97	+161
2.2. In età non lavorativa	3.001	3.102	6.104	2.969	3.053	6.022	—32	—49	—82
2.2.1. i ragazzi fino a 13 anni	2.471	2.420	4.890	2.430	2.342	4.772	—41	—78	—118
2.2.2. persone di 71 anni ed oltre	531	682	1.213	539	711	1.250	+8	+29	+37
Totale popolazione a)	9.777	10.205	19.982	9.851	10.264	20.115	+74	+59	+133
Tassi di attività % b)	51,0	21,5	36,0	51,2	21,6	36,1	—	—	—
Tassi di disoccupazione % c)	8,1	21,5	12,2	9,0	21,9	13,0	—	—	—
Tassi di disoccupazione/sottoccupazione «esplicita» % d)	9,8	29,7	16,3	10,5	30,0	16,7	—	—	—

Fonte: Istat, «Rilevazione delle forze di lavoro, media 1981 e media 1982», in *Supplemento al Bollettino mensile di statistica*, n. 3/1982 e n. 2/1983

Key:

1. Labor Force
  - 1.1 Employed Persons
    - 1.1.1 Who have said they are employed
    - 1.1.2 Who have not said they are employed, but who put in working hours during the week in question
  - 1.2 Persons seeking employment
    - 1.2.1 Unemployed previously
    - 1.2.2 Seeking first job
    - 1.2.3 Who have said that they do not have professional status, but have sought work
2. Persons not belonging to labor force
  - 2.1.1 Prepared to engage in work under certain conditions
  - 2.1.2 Without possibility or interest in seeking work
  - 2.2 Not of working age
    - 2.2.1 Children up to 13 years old
    - 2.2.2 Persons 71 years old and over

[Table 1, continued]

- a) Total Population
- b) % Rate of activity
- c) % Rate of unemployment
- d) % Rate of "explicit" unemployment/underemployment

M: Male      F: Female

Source: ISTAT [Central Statistics Institute], "Survey of Labor Force, 1981 Average and 1982 Average," in SUPPLEMENTO AL BOLLETTINO MENSILE DI STATISTICA, No 3/1982 and No 2/1983

Table 2. Unemployment Rates According to Geographic Area and Sex (Percentage Variations)

Tab. 2 - Tassi di disoccupazione per area geografica e sesso (Variazioni percentuali)										
Anni a)	Maschi b)					Femmine c)				
	d) 1° trim.	e) 2° trim.	f) 3° trim.	g) 4° trim.	h) Media annua	d) 1° trim.	e) 2° trim.	f) 3° trim.	g) 4° trim.	h) Media annua
				i) Mezzogiorno						
1977	6,09	5,85	7,05	6,68	6,42	17,14	17,35	21,91	19,61	19,00
1978	6,56	6,40	6,85	6,53	6,58	17,26	16,94	19,07	18,92	18,05
1979	7,23	7,20	7,95	7,04	7,35	17,07	17,95	21,09	19,14	18,81
1980	7,54	7,20	8,12	7,23	7,52	19,12	18,10	22,99	20,34	20,14
1981	7,57	7,64	8,14	8,88	8,06	18,51	20,73	23,92	22,99	21,54
1982	9,19	8,41	9,47	8,98	9,01	21,77	20,93	23,40	21,60	21,92

Fonte: Istat

Key:

- a) Years
- b) Men
- c) Women
- d) 1st Qtr.
- e) 2nd Qtr.
- f) 3rd Qtr.
- g) 4th Qtr.
- h) Ann. Avg.
- i) South

Source: ISTAT

Table 3. Persons seeking employment in the south in 1981 and 1982  
(annual averages of quarterly surveys--thousands of persons)

Tab. 3 - Persone in cerca di occupazione nel Mezzogiorno nel 1981 e nel 1982 (medie annue delle rilevazioni trimestrali - migliaia di unità)			
Età a)	1981	1982	'82/'81
14-19 anni	248	260	+12
20-24 anni	309	324	+15
25-29 anni	139	155	+16
30-39 anni	83	91	+ 8
40-49 anni	40	48	+ 8
50-59 anni	25	32	+ 7
60-64 anni	8	10	+ 2
65-70 anni	10	9	- 1
b) 71 anni e oltre	13	13	—
c) Totale	876	942	+66

Fonte: cfr. tab. 1

Key:

- a) Age
  - 14-19
  - 20-24
  - 25-29
  - 30-39
  - 40-49
  - 50-59
  - 60-64
  - 65-70
- b) 71 and over
- c) Total

Source: Cf. Table 1

Table 4: Employed Persons According to Occupational Status, Sector of Economic Activity and Geographic Distribution (average of four surveys taken in 1982--absolute figures in thousands)

Tab. 4 - Occupati secondo la posizione nella professione, il settore di attività economica e la ripartizione geografica (media delle quattro rilevazioni eseguite nell'82 - Cifre assolute in migliaia)

c) Ripartizioni geografiche	a) Occupati in complesso				b) Occupati alle dipendenze			
	d) Agricoltura	e) Industria	f) Altre attività	g) Totale	h) Agricoltura	e) Industria	f) Altre attività	g) Totale
	Anno 1982							
Italia settentrionale h)	863	4.538	4.898	10.299	197	3.876	3.387	7.460
Italia centrale i)	356	1.353	2.347	4.056	104	1.112	1.723	2.939
Italia meridionale e insulare j)	1.326	1.707	3.290	6.323	671	1.398	2.332	4.401
Italia k)	2.545	7.598	10.535	20.678	972	6.386	7.442	14.800
	1) Variazioni percentuali (1982 su 1981)							
Italia settentrionale h)	- 6,5	-2,2	+0,6	-1,2	-5,3	-2,8	+0,5	-1,4
Italia centrale i)	-13,8	-0,7	+5,0	+1,1	-1,9	-2,4	+3,9	+1,2
Italia meridionale e insulare j)	- 6,8	-1,1	+4,0	+0,2	-4,8	-0,8	+3,9	+1,0
Italia k)	- 7,8	-1,7	+2,6	-0,4	-4,6	-2,3	+2,3	-0,2

Fonte: Istat

Key:

- a) Total Employed
- b) Employed by Others
- c) Geographic Distribution
- d) Agriculture
- e) Industry
- f) Other Sectors
- g) Total
- h) Northern Italy
- i) Central Italy
- j) Southern Italy and Islands
- k) Total Italy
- l) Percentage Variations (1982/1981)

Source: ISTAT

[3 Jun 83 pp 26-27]

[Text] Following a first overall look at the incidence of unemployment-underemployment in the south (RASSEGNA SINDACALE No 20), we now look at how this phenomenon is interrelated in the various production sectors, and especially in the various geographic areas, at a stage in which the crisis does not allow much hope.

The internal composition of the various production sectors shows that from the standpoint of the ratio of persons employed by others to self-employed persons (see the survey published in RASSEGNA SINDACALE No 20, 20 May 1983, Table 4), the greatest discrepancy between the south and the rest of Italy is found in the agricultural sector, since 50.6 percent of those employed in this sector are represented by persons employed by others, as compared to 29.21 percent in central Italy and 22.8 percent in northern Italy. It is also in the agricultural sector that phenomena of underemployment/unemployment are most readily found.

In particular, the various patterns of unemployment/underemployment are dependent on the considerable differences between internal areas and metropolitan areas, between agricultural areas and urban areas, between the behavior of unemployment of educated persons and the behavior of traditional unemployment. The feature to which the various patterns seem to be related derives from the various kinds of relationships with temporary job opportunities, with the various existing underemployment opportunities in relation to the features of the productive context.

To this end, Nicola Boccella (in his recent essay, "The Subsidized South," Angeli 1983) points out another basic aspect of the question which we are examining, that of the government's role in administering the flow of subsidies, in implementing a policy of supporting incomes in agricultural areas, whereas in urban areas the same policy is implemented by increasing employment in the public sector. It could thus be said that the characteristics of the internal composition of the individual sectors, in order to be significant, must be related to the other variables listed above.

There are essentially two patterns of underemployment/unemployment: that of internal and rural areas and that of urban-metropolitan areas (see note 1). In the first case, explicit unemployment is, to a large extent, comprised of young persons with rather high educational qualifications that they find in the family income, aided by the flow of subsidies, an opportunity of support. In fact, in these areas, the opportunity for employment in the public sector is very limited. Thus we find a willingness to move to the nearest metropolitan areas or to the north.

It is interesting to note that within this first pattern, a position of particular importance is occupied by the labor force of young women in the interior, constituting a subpattern to some degree. At the base of this type of employment are migrants [pendolarita]: young female day laborers under the supervision of foremen--this situation has rightly been described as the

"single major employment agency and supplier in the south" (see note 1)--who are employed in lowland agricultural businesses at low salaries. The young people in these latter areas do not return to the illustrated pattern, for since they can count on job opportunities which are less rarefied and less subject to harsh exploitation, they tend to reject employment in agriculture. Thus they become part of the urban-metropolitan pattern. It should be noted that within this latter pattern there are marked differences between employment opportunities in intermediate tertiarized cities such as Catanzaro, Potenza, Cosenza and cities with an industrial presence such as Taranto and Naples. In these areas, to some extent, there are job opportunities (often involving dirty work) deriving from a minimum of productive distribution in the field of manufacturing activities. The underground manufacturer is clearly present in the area in a diversified manner in terms of both quality and quantity.

In the present economic situation, the ability of this type of pattern to endure may well be extremely weak, since an increasingly difficult, since the spring of 1982, and rapidly deteriorating, since early autumn of last year, situation has been recorded in the south (see note 2). To use the words of the IASM [Institute for Southern Development Assistance] study on the trend of a sampling of 600 businesses in the fourth quarter of 1982, it could be said that "the use of the labor factor has thus once again turned out to be subject to growing tensions. In this regard, statistical indicators provide a partial view of the degree of deterioration which currently distinguishes the employment situation in the south, although the respective figures differ from the national average at extremely high levels....Among other things, in fact, official figures do not include a broad area of employment (of a temporary or underground nature) which the present new outbreak of recession has struck first and which will likely be the last to be reabsorbed, nor do any 'shock absorbers' exist for this kind of employment" (see note 2). The figures indicating this negative trend tell us (see Tables 1 and 2) that the 600 businesses polled gave predominantly negative answers. The trends pointed to a declining overall orders portfolio; on the average, in 39 percent of the cases, this type of trend has caused a reduction of activity: the difference between increasing and decreasing replies was -12 percentage points, with -19 percentage points in the case of small companies. Thus the use of labor was limited; hours have tended to decline with a reduction of employment which jointly involved the different types of industry considered in the study. Even plant use was modest (71 percent on the average, in particular 66 percent for small industries, 72 percent for average industries and 74 percent for large industries).

Overall, 60 percent of the southern industries polled consider the present period totally unsatisfactory. In some sectors, the negative replies were considerably greater than the average value recorded: 100 percent in the photo-phono-cinematographic industry, 80 percent in the rubber industry, and 88 percent in the furniture and furnishings industry (see Table 3).

The difficulty of the situation is also underscored by the state of the unemployment insurance system; in particular, the column reporting the rates of change for 1981/1982 shows how the most imposing changes have occurred in

three southern regions: Molise, Calabria and Sardinia, even if consideration must be given to both absolute values (modest) and the unemployment insurance system's effect on the national total for working hours. However, the southern industrial structure, with the exception of Lazio and Sicily, where decreases were recorded, had rates of change much higher than the overall rate of change, which is 17.3 percent.

Table 1. Exportation Orders and Level of Production. Productive Capacity in Relation to Orders and Extent of Plant Use.

Tab. 1 - Esportazione. Ordini e livello della produzione. Capacità produttiva in relazione agli ordini e grado di utilizzo degli impianti

	a) Mezzogiorno			e) Totale
	b) Piccole 20-100 addetti	c) Medie 101-500 addetti	d) Grandi oltre 500 addetti	
Aziende che f) } — esportano g) }	21	44	72	46
— esportano occasionalmente h) }	12	15	12	13
— non esportano i) }	67	40	16	41
Percentuale di prodotto esportato j)	28	29	21	25
Consistenza portafoglio ordini k) }				
— elevata l) }	12	5	21	12
— normale m) }	42	44	49	45
— bassa n) }	46	51	31	43
Livello della produzione o) }				
— elevato l) }	11	6	33	16
— normale m) }	49	47	37	44
— basso n) }	40	48	29	39
Capacità produttiva in relazione agli ordini p) }				
— esuberante q) }	38	41	39	39
— sufficiente r) }	57	56	57	57
— insufficiente s) }	5	3	4	4
Grado di utilizzo degli impianti (in % del massimo utilizzo) t)	66	72	74	71

Fonte: Indagine Iasm. Le imprese industriali del Mezzogiorno nel quarto trimestre 1982

Key:

- |   |  |
|---|--|
| a) South                                | j) Percentage of Product Exported            |
| b) Small Companies, 20-100 Employees    | k) Consistency of Orders Portfolio           |
| c) Average Companies, 101-500 Employees | l) ---high                                   |
| d) Large Companies, Over 500 Employees  | m) ---average                                |
| e) Total                                | n) ---low                                    |
| f) Businesses which                     | o) Level of Production                       |
| g) --export                             | p) Productive Capacity in Relation to Orders |
| h) --export occasionally                | q) --excessive                               |
| i) --do not export                      | r) --sufficient                              |
|   | s) --insufficient                            |
|   | t) Extent of Plant Use (in % of maximum use) |

Source: IASM survey, Industrial Companies in the South in the Fourth Quarter of 1982.

Table 2. Comparison of Fourth Quarter of 1982/Fourth Quarter of 1981. Orders, Production, Labor, Hours Worked, Plant Use.

Tab. 2 - Confronto IV trim. '82/IV trim. '81. Ordini, produzione, manodopera, ore lavorate, utilizzo degli impianti

	a) P.	b) M.	c) G.	d) T.
Portafoglio ordini e)				
— in complesso: f)				
superiore g)	29	36	42	35
uguale h)	31	20	26	26
inferiore i)	41	44	32	39
— dall'interno: j)				
superiore g)	27	35	42	34
uguale h)	31	22	26	26
inferiore i)	42	44	32	39
— dall'estero: k)				
superiore	28	39	27	32
uguale	35	21	44	33
inferiore	37	41	29	35
Produzione l)				
— superiore	25	36	17	26
— uguale	38	25	51	38
— inferiore	36	39	32	36
Manodopera m)				
— superiore	11	20	17	16
— uguale	63	48	56	56
— inferiore	26	32	27	28
Ore lavorate n)				
— superiore	14	28	17	20
— uguale	55	38	45	46
— inferiore	31	35	37	34
Utilizzo degli impianti o)				
— superiore	18	32	17	23
— uguale	48	33	41	41
— inferiore	34	35	41	37

Fonte: Indagine Iasm. Le imprese industriali del Mezzogiorno nel quarto trimestre 1982

Key:

- a) Small Companies, 20-100 Employees
- b) Average Companies, 100-500 Employees
- c) Large Companies, Over 500 Employees
- d) Total
- e) Order Portfolio
- f) --Overall:
- g) Greater
- h) Same
- i) Less
- j) --Domestic:
- k) --Foreign:
- l) Production
- m) Labor
- n) Hours Worked
- o) Plant Use

Source: IASM Survey, Industrial Companies in the South in the Fourth Quarter of 1982

Table 3. Economic Trend

Tab. 3 Andamento della congiuntura

	dd) Mezzogiorno				Mezzogiorno			
	a)	b)	c)	d)	P	M	G	T
01 Estrattive favorevole f) e) sfavorevole g)	18	67	0	27				
02 Industrie alimentari e affini h)	82	33	100	73				
- favorevole	59	61	0	59				
- sfavorevole	41	39	100	41				
03 Industrie del tabac. i)								
- favorevole	0	100	100	100				
- sfavorevole	0	0	0	0				
04 Tessili j)								
- favorevole	40	29	50	38				
- sfavorevole	60	71	50	63				
05 Vestiario, arredamento, abbigliamento k)								
- favorevole	45	43	0	42				
- sfavorevole	55	57	100	58				
06 Calzature l)								
- favorevole	30	33	0	30				
- sfavorevole	70	67	0	70				
07 Pelli e cuoio m)								
- favorevole	29	0	0	29				
- sfavorevole	71	0	0	71				
08 Legno e sughero n)								
- favorevole	29	0	0	29				
- sfavorevole	71	0	0	71				
09 Mobilio e arredamento in legno o)								
- favorevole	13	0	0	13				
- sfavorevole	87	100	0	88				
10 Metallurgiche p)								
- favorevole	100	0	50	50				
- sfavorevole	0	100	50	50				
11 Meccaniche q)								
- favorevole	39	29	0	36				
- sfavorevole	61	71	100	64				
12 Costruzione mezzi di trasporto r)								
- favorevole	67	67	75	70				
- sfavorevole	33	33	25	30				
13 Materiali da costruzione s)								
- favorevole	27	22	0	26				
- sfavorevole	73	78	0	74				
14 Chimiche e derivati del petrolio t)								
- favorevole	35	0	0	29				
- sfavorevole	65	100	100	71				
15 Gomma u)								
- favorevole	25	0	0	20				
- sfavorevole	75	100	0	80				
16 Cellulosa per usi tessili e fibre v)								
- favorevole	0	0	0	0				
- sfavorevole	0	0	0	0				
17 Carta e cartotecnica w)								
- favorevole	64	33	0	59				
- sfavorevole	36	67	0	41				
18 Poligrafiche ed editoriali x)								
- favorevole	57	0	0	57				
- sfavorevole	43	0	0	43				
19 Foto-fono-cinematografiche y)								
- favorevole	0	0	0	0				
- sfavorevole	100	0	0	100				
20 Materie plastiche z)								
- favorevole	44	0	0	40				
- sfavorevole	56	100	0	60				
21 Manifatturiere varie aa)								
- favorevole	44	0	0	36				
- sfavorevole	56	100	0	64				
Totale manifatturiere bb)								
- favorevole	41	35	47	40				
- sfavorevole	59	65	53	60				
Totale ind. rilevate cc)								
- favorevole	41	36	44	40				
- sfavorevole	59	64	56	60				

Fonte: Indagine Iasm. Le imprese industriali del Mezzogiorno nel quarto trimestre 1982

## Key:

- |    |                                     |     |  |
|----|-------------------------------------|-----|--|
| a) | Small Companies 20-100 Employees    | s)  | 13 Building Materials                    |
| b) | Average Companies 100-500 Employees | t)  | 14 Chemical and Petroleum Derivatives    |
| c) | Large Companies, Over 500 Employees | u)  | 15 Rubber                                |
| d) | Total                               | v)  | 16 Cellulose for Textile Uses and Fibers |
| e) | 01 Extrative Industries             | w)  | 17 Paper and Paper Products              |
| f) | Favorable                           | x)  | 18 Printing and Publishing               |
| g) | Unfavorable                         | y)  | 19 Photo-phono-cinematographics          |
| h) | 02 Food and Related Industries      | z)  | 20 Plastics                              |
| i) | 03 Tobacco Industries               | aa) | 21 Miscellaneous Manufacturing           |
| j) | 04 Textiles                         | bb) | Total Manufacturing                      |
| k) | 05 Clothing and Furnishings         | cc) | Total Industries Surveyed                |
| l) | 06 Footwear                         |     |  |
| m) | 07 Hides and Leather                |     |  |
| n) | 08 Wood and Cork                    |     |  |
| o) | 09 Furniture and Wooden Furnishings |     |  |
| p) | 10 Metallurgical Industries         |     |  |
| q) | 11 Mechanical Industries            |     |  |
| r) | 12 Construction, Transportation     |     |  |

Source: IASM Survey, Industrial Companies in the South in the Fourth Quarter of 1982

## NOTES

1. For a more detailed explanation, compare the report by E. Pugliese: "The Labor Market and Problems of Employment," given at the IRES-CGIL conference on "Public Intervention and Development in the South," 22-23 February 1983, Rome.
2. IASM (Institute for Southern Development Assistance): Economic survey on "Industrial Companies in the South in the Fourth Quarter of 1982." This survey was conducted on a significant sampling of 600 companies. The basic sampling unit was the production plant dislocated from the south; the whole was composed of local plants with 20 dependents and also recorded by ISTAT in the fifth general census of industry and commerce in 1971.

11915

CSO: 3528/154

## PAPER COMMENTS ON OECD RECOMMENDATIONS ON ECONOMY

Oslo AFTENPOSTEN in Norwegian 18 Jul 83 p 2

[Editorial: "Economic Upturn"]

[Text] The OECD [Organization for Economic Cooperation and Development] report for the last half of the year confirms that the industrial world is again in a period of upturn. According to the report, the economic growth in the OECD countries is expected to increase further in the second half of the year and stabilize at slightly over 3 percent next year. Most of the experts are, however, cautious in their forecasts of how strong and long-lasting the upturn will be and it seems to be especially associated with great uncertainty of the development in the European OECD countries. Some feel that the prognosis for this area are admittedly cautious and that the upturn has a more solid base than the report indicates. Let us hope that this proves correct.

The OECD prognoses for Norway are relatively pessimistic as the economic growth is only considered to be 0.25 percent this year and 1 percent next year. The reason is that OECD expects a continued weakening of the competitive capability of Norwegian industry internationally and that it will worsen by approximately 3.5 percent in 1984. This might indicate that the OECD experts are not sufficiently informed about recent development in Norway. But it can also be connected with the fact that OECD looks more realistically ahead with regard to what will happen to prices and costs here at home than what certain optimistic predictions indicate. The development of the wage drift is an important uncertainty factor.

Currently, our price and cost development is a little bit on the high side of that trend in our most important competitive countries. OECD also forecasts that the rise in prices is expected to drop to 7 percent from 1983 to 1984, while that figure for the OECD countries as a whole is expected to be approximately 6 percent. With respect to Norway, this means that the wage drift must be kept within a very restrictive limit and that next year's wage settlement will be limited. The prerequisite for implementing this economic policy will, in other words, be to lower the price and cost growth sufficiently so the competitive capabilities do not weaken simultaneously while domestic demand is maintained. And we must reach this balance without the finance and credit policies becoming too expansive.

As this is the problem situation, that we must bring the price increases more in line with the countries we compete with, it is immediately understandable how unsuitable the Labor Party's alternatives are under the current economic conditions. The Labor Party's demand for a considerably stronger increase of public expense is a guaranteed road to more inflation, less competitive capability and loss of thousands of work places in idle businesses. It is plainly a policy that will bring mass unemployment in the long-term.

9583

CSO: 3639/149

## TRADE SURPLUS FOR FIRST SIX MONTHS OF 1983 ALMOST DOUBLES

Oslo AFTENPOSTEN in Norwegian 14 Jul 83 p 8

[Article by Bjorn H. Tretvoll: "Export Surplus Almost Double: Record for Norwegian Foreign Trade"]

[Text] The Norwegian export surplus was almost twice as large during the first half of this year as during the same period last year. With a development for the remainder of the year which corresponds to what the authorities have indicated in the Revised National Budget, the Norwegian foreign trade surplus for 1983 may be higher than during the record year of 1981 when the balance of foreign trade showed a surplus of 13.2 billion kroner.

The current figures from the National Bureau of Statistics which were published on Wednesday, show that the export surplus for the period January-July reached 14.3 billion kroner compared to 7.4 billion kroner during the same period last year.

One of the main reasons for this strong improvement is a considerable increase in the export value of gas and oil from the North Sea. Despite lower international oil prices, high oil production and favorable rate of exchange of the American dollar have resulted in an increase of the total export value of oil and gas from 25.9 billion kroner during the first half of last year to 31.6 billion kroner during the same period this year.

"These figures for foreign trade point in the direction of a surplus in foreign operational accounts of about 11 billion kroner during the first half of this year," says Chief Economist Tormod Andreassen of the Credit Fund to AFTENPOSTEN. This is considerably better than the authorities had expected. Even though the development will not be more favorable for another half a year than what the Revised National Budget was based on, we can have a surplus in Norwegian foreign trade for 1983 which is on the high side of the record figure of 13.2 billion kroner from 1981.

The total import value during the first half of the year was 46.2 billion kroner which is an increase of 2.3 percent from the same period last year. The export value rose by 15 percent to 60.5 billion kroner. The purchasing and selling of ships are not included in these figures.

In June alone the export surplus was 1.8 billion kroner, compared to a deficit of 218 million kroner during the same month last year. The imports dropped by 5.3 percent to 8.2 billion kroner while the exports increased by 18.1 percent to 9.9 billion kroner.

The figures for foreign trade also demonstrate what a dominating position the export of oil and gas has taken in Norwegian foreign economy. Of the total export value of 60.5 billion kroner, 31.5 billion kroner are for the sale of oil and gas.

The seasonally corrected figures for April-June show a rise of 5.1 percent in the import value from the previous 3-month period. The export value rose by 0.9 percent. Ships, drilling and production platforms, as well as export of oil and gas are not included in these figures.

"The figures for the second half of the year will not be as favorable as those during the first half of the year. A high exchange rate of the dollar during the next months will, however, contribute to more favorable figures for the oil sector, but in a long-term view, the development in the exchange rate of the dollar represents a considerable factor of uncertainty," says Andreassen.

9583

CSO: 3639/149

## MADRID PREFERS DIALOGUE TO ECONOMIC WAR OVER GIBRALTAR

Madrid YA in Spanish 2 Aug 83 p 11

[Article by Jose V. Colchero]

[Text] Spain does not want to wage "economic war" to decolonize Gibraltar but, rather, to promote understanding among the inhabitants on both sides of the barrier, facilitating a political dialogue between London and Madrid, in order to resolve peacefully the dispute over sovereignty of the Rock usurped by England 280 years ago tomorrow. It was in furtherance of this policy that Foreign Minister Moran visited the Gibraltar countryside at the end of last week.

Since the British colony can never be independent, because this would be contrary to the Treaty of Utrecht, in which the military fortress was ceded to Great Britain, and it is a non-self-governing territory that, according to the United Nations mandate, has to be decolonized, London and Madrid have to contrive means to restore sovereignty over it that will redound to the benefit of the region's inhabitants.

This is the "spirit" that will motivate Moran when he meets in September with his British colleague, Geoffrey Howe, who has the reputation of a "hawk," but who it is hoped is strongly inclined, like the good Englishman he is, to be pragmatic. Prime Minister Thatcher, the "iron lady," won the June elections and with five years of legislative control, has to deal with the two most important decolonizing processes pending, those pertaining to Hong Kong and Gibraltar (as a consequence of last year's war, the process of decolonizing the Malvinas through mutual collaboration may be more difficult for the foreseeable future).

#### The Spanish Government's Historic Responsibility

Without doubt, Felipe Gonzalez' government is faced with a tremendous historic responsibility, since it has to find in the coming years a means of reaching an understanding with Great Britain concerning the Gibraltar dispute, especially as the process of decolonization is being opened up everywhere in the world in this second half of the 20th century. Gibraltar can never be an independent state, a San Marino in the Bay of Algeciras. Nor can it remain a British colony forever. The formula for a solution

has to be sought in the creation of an autonomous economic and fiscal zone, with a special statute applicable to the people on both sides of the barrier. Nevertheless, this must be preceded by a process of restoration of sovereignty, by an undertaking on the part of the colonial power to finish peacefully with the present anachronistic "status."

By the end of 1984, Mrs Thatcher will have resolved with Deng Xiaoping's China the devolution of sovereignty over Hong Kong, ceded to the British Crown in perpetuity by the Treaty of Nanking in 1842, just as we had ceded Gibraltar in the Treaty of Utrecht. Afterward, in 1898, London "rented" from China for 99 years the "New Territories," which are nine times larger than the colony itself and without which the latter could not live. The "New Territories" of the British colony on Spanish soil are the localities of the Gibraltar countryside, which, with the Rock, could form a geographic, economic and fiscal unit.

The solution that London and Beijing contrive to resolve the decolonization of Hong Kong and arrange for its 6 million inhabitants to continue enjoying their present prosperity could serve as a model in many respects for an arrangement resulting in the achievement of a prosperous joint "modus vivendi" for the barely 30,000 British Gibraltarians and the several thousand Spaniards in the Gibraltar countryside; thus, the Spanish-British colonial dispute would end, and this would bring with it great benefits for Europe (including the EEC) and for the western world. It would also allow Great Britain to cease spending hundreds of millions of pounds on a colony, which, if it continues to be one, could not count on the economic and strategic protection of the surrounding area. What Gibraltar must never again be is a British colony living parasitically off of Spain.

12336

CSO: 3548/483

## FULL-SCALE CAMPAIGN TO INTENSIFY TAX AUDITING

Istanbul CUMHURİYET in Turkish 10 Jul 83 pp 1, 7

[Article by Rafet Genc: "Turkey Divided into Five Audit Zones"]

[Text] Ankara -- The Finance Ministry is beginning its "intensive and extensive" nationwide tax auditing after Ramadan. The practices begun earlier in the cities of Ankara, Istanbul and Izmir as the pilot zones are being extended nationwide after the holidays.

Administrative personnel, income comptrollers and accountants from the capital are starting on the audits, working with local auditors. The Finance Ministry drew up a program for the audits which divides Turkey into five zones to facilitate smooth accomplishment of the tax audits. Audit personnel are assigned in groups to specific zones where they will be conducting intensive and extensive audits until the first of the year.

According to the program, more than 1,000 auditors will be examining in "persistent and orderly" fashion all movements of goods, production of goods and the status of the service sector in all provinces.

Districts will also be checked in the audits to begin nationwide on 18 July. Also, auditors will spend long periods of time at all kinds of purveyors of services (hotels, restaurants, motels, guest homes and tourist spots) to "determine daily volumes."

In addition, auditors will visit the business establishments of doctors and other independent professionals to determine their daily volumes and will monitor individually the "physical production stages" of large manufacturers, factories, cement and steel producers and establishments making finished products of cement and steel.

#### Special Forgiveness Law

In conjunction with this, taxpayers who have not taken advantage of Special Amnesty Law No 2801, that is, who have not reported higher taxable income in recent years will be invited to their tax offices where they may be asked to update their tax forms and a tax audit may be made if necessary.

A close check will be made for compliance with the standard of living base placed in effect the first of the year 1983. Tourist attractions, hotels and motels and guest establishments will be checked and asked whether they have stated their income according to the standard of living base.

The incomes of those who vacation abroad will also be closely checked.

Personnel will also be trained during the audit which is to be applied throughout the nation, including Hakkari.

According to the audits made so far, approximately 1.5 million taxpayers have raised their tax status. Around 1 million taxpayers have reportedly taken advantage of the special forgiveness law, No 2801. According to initial estimates, around 1 million more taxpayers will be making additional declarations.

Istanbul reportedly has the most taxpayers with 700,000 and Hakkari has the fewest, about 1,000.

8349

CSO: 3554/368

## TUSIAD REPORT ON SHORT, MEDIUM-TERM PLANNING

Istanbul DUNYA in Turkish 9 Jul 83 pp 1, 7

[Text] NEWS CENTER -- The Turkish Industrialists' and Businessmen's Association, TUSIAD, says that the private sector needs to have a clear view of the direction it will be taking in the future and that, to enable this, the government must adopt a policy encompassing at least short- and medium-term policy. Formation of a corporate structure is called for in order to meet this need.

TUSIAD published its report, "Turkish Economy 1983," in English. The report evaluates economic data and developments for 1982 and the first 6 months of 1983 and includes proposals on reviving investments, increasing export rates and post-election economics.

The report notes that the State Planning Organization's Annual Development Programs are inadequate and says that a corporate structure is needed for medium- and short-term policies to be formulated and implemented. It also notes that government regulations need to be simplified and revised so as to harmonize with current needs and the international market experience.

The report says that export productivity and import substitution must be encouraged, not by subsidizing exports and banning imports, but by placing a great deal more emphasis on foreign exchange rates and customs duties as policy vehicles.

#### Inflation Must Come Down

It says that the increasing importance given to foreign exchange rate adjustments, and inflation as well, must be reduced to the levels in the countries which are Turkey's primary Western trading partners, adding, "Otherwise, continuous adjustments will be required in order to protect the competitive strength in exports."

With a reminder that private sector investments were negligible in 1982, the report notes that no significant development in total investments is expected in 1983, but a relative increase has been observed in the investments in one or two sectors. Attention is drawn to the climate of confidence abroad that came with the measures adopted in 1980, indicating that an even more pronounced improvement is expected to come with the announcement of the policies it intends to pursue by the government that will be formed when the parliamentary order is restored towards the end of the year. The report says that early approval of its proposals will be tantamount to increasing domestic investments as well as foreign investments, pointing out that Turkey has an urgent need for foreign capital for specific projects and investment areas.

With the reminder that these are the way to reduce the cost of creditable funds for use in the private sector's completely local and joint investments, the report lists the following measures: Lifting the transaction tax on financial procedures, reducing the cost of reserves held at the Central Bank, taxing interest income on the basis of real, not nominal, interest and reducing further the operational deficits of the state enterprises. It is stated in this context that the steps taken to reorganize the state economic enterprises may achieve definite results, but they remain vulnerable to political interference.

8349

CSO: 3554/368

## AKEL-CPSU JOINT COMMUNIQUE ON PAPAIOANNOU VISIT

Nicosia KHARAVGI in Greek 31 Jul 83 p 1

[Text] An AKEL delegation consisting of the secretary general of the party, E. Papaioannou, the assistant secretary general A. Fandis, and a member of the Politburo of the Central Committee and member of the Central Secretariat, G. Katsouridis, had a meeting in Moscow with the secretary general of the CPSU Central Committee and chairman of the Presidium of the USSR Supreme Soviet, G. V. Andropov, who wished the communists of Cyprus success in their activity for the good of the Cypriot people and the cause of a lasting peace.

According to an announcement by the CPSU Central Committee and the AKEL Central Committee, the AKEL delegation also had a meeting with the alternate member of the Politburo of the CPSU Central Committee and secretary of the CPSU Central Committee, Boris (Ponomarev), and with the CPSU Central Committee member and first alternate in charge of the international division of the CPSU Central Committee, V. V. (Zanglatsin). In the course of the meeting, the CPSU delegation expressed the complete solidarity of the Soviet Union with the anti-imperialist struggle of AKEL and the Cypriot people and emphasized that the convening of a representative international conference on Cyprus within the framework of the United Nations would be able to contribute to its success.

Also discussed during the meeting was the international situation in light of the increased aggressiveness of American imperialism, and the importance was stressed of strengthening the unity of the international communist movement and strengthening friendship and solidarity among all the revolutionary forces of the contemporary period.

The Announcement

The complete text of the joint announcement is as follows:

"The CPSU Central Committee received a delegation from the Restorative Party of the Working People of Cyprus (AKEL), which consisted of the secretary general of AKEL, E. Papaioannou, the assistant secretary general of AKEL, A. Fandis, and a member of the Politburo of the Central Committee

and of the Central Secretariat of AKEL, G. Katsouridis. The secretary general of the CPSU Central Committee and chairman of the Presidium of the USSR Supreme Soviet, G. V. Andropov, warmly welcomed the AKEL delegation and wished the communists of Cyprus success in their activity for the good of the Cypriot people and the cause of a lasting peace.

"There was a meeting of the AKEL delegation with the alternate member of the CPSU Central Committee Politburo and secretary of the CPSU Central Committee, Boris (Ponomarev), and also with a member of the CPSU Central Committee and first alternate in charge of the international division of the CPSU Central Committee, V. V. (Zanglatsin).

"The CPSU representatives reported on the work of the Soviet communists on behalf of the materialization of the decisions of the CPSU's 26th Congress and the plenums of the CPSU Central Committee of November (1982) and June (1983), which aimed at the planned and comprehensive improvement of the developed socialist society in the USSR, at restoring international relations to a healthy condition, and at ensuring peace and avoiding a thermonuclear war. The AKEL delegation made a very positive assessment of the consistently peaceloving foreign policy of the CPSU and the line which it is following for the sake of a further increase in the material and cultural level of the Soviet people, and it emphasized the great international significance of the decisions of the CPSU Central Committee plenum of June and its program positions and conclusions on the chief problems of the contemporary period.

#### For Detente and Peace

"The participants at the meeting expressed grave concerns about the abrupt increase in the aggressiveness of the reactionary forces of international imperialism, headed by warmongering circles in the United States whose militaristic intentions aim at upsetting the military balance, achieving military superiority over the USSR and the other socialist countries, and imposing its imperialist hegemony over international affairs. And both parties rendered clear their steadfast determination to continue, along with all the other progressive and peaceloving forces, to struggle for detente, for stopping the arms race, for disarmament, and for the elimination of nuclear and other weapons of mass destruction.

"The delegations of the CPSU and AKEL condemned the flagrant anticommunist and anti-Soviet campaigns of lies and slanders with which the Reagan administration is trying to justify the arms race, to impose on its allies its adventurous policy, to impede the development of the mass peace movement, and to continue preparing for a nuclear war. They especially condemned the effort by American imperialism to install its new missiles in Europe-- an event which would magnify extremely the danger to the security of the peoples of this continent and to peace throughout the world.

"The CPSU and AKEL place primary importance on strengthening the unity of the international communist movement and on strengthening friendship and solidarity among all the revolutionary forces of the contemporary period.

## On the Cyprus Problem

"The representatives of AKEL gave a briefing on the struggle of the Cypriot people for a just settlement of the Cyprus problem. It was emphasized that the Cyprus question is passing through a critical period, as a result of the imperialist conspiracy against Cyprus, which has as its aim the dissolution of the independent Cypriot State or the imposition of a NATO solution which is unacceptable to the country. The party is waging a resolute struggle against the foreign occupation and the militaristic aspirations of the reactionary circles of the United States and NATO, and against their interference in the domestic affairs of Cyprus, it is earnestly striving to rally all the patriotic forces of the country, and it consistently supports a solution to the Cyprus problem based on the resolutions of the United Nations and the summit agreements, via constructive inter-communal talks aimed at ensuring the independence, sovereignty, territorial integrity, non-aligned status, and the demilitarization of a federated Cyprus which is free of all foreign troops and bases.

"In connection with this, AKEL supports the efforts of the secretary general of the United Nations for a peaceful settlement in Cyprus.

"The CPSU delegation expressed its complete solidarity with the anti-imperialist struggle of AKEL and of the Cypriot people, emphasizing that the convening of a representative international conference on Cyprus within the framework of the United Nations would be able to contribute to the success of this effort.

"Both delegations affirmed the desire of the CPSU and AKEL to further develop the genuinely fraternal relations which have been established between them on the basis of the principles of Marxism-Leninism and proletarian internationalism.

"Moscow, 26 July 1983."

12114

CSO: 3521/409

## AKEL DEPUTY STRESSES NEED FOR PRESS ATTACHES' GUIDANCE

Nicosia O AGON in Greek 1 Aug 83 pp 1, 12

[Text] Minister of Foreign Affairs Rolandis stated that there is no direct contact between the Cypriot government and the Greek embassies in those countries where Cyprus does not have diplomatic representation, but that the Ministry of Foreign Affairs of Cyprus is in constant contact with the Greek embassy in Nicosia, by which it is being briefed.

Rolandis, who briefed the House of Representatives on the topic "the diplomatic representation of Cyprus throughout the world," said in response to a question by the leader of EDEK [United Democratic Union of the Center], Lyssaridis: "Of course, we do not have direct access to the Greek embassies, but we are in constant contact with the Greek embassy here and are being briefed by it."

The question by Lyssaridis (page 3 of the minutes) to Rolandis is as follows:

"Given that no matter what we do the number of embassies will be limited, I would like to know how far we have developed cooperation on matters of promoting the national cause via the Greek embassies in countries where Cyprus does not have a diplomatic representation."

Galanos Question

Galanos: "Are you satisfied, or do you believe that there is room for improvement?"

Rolandis: "I am satisfied. As I stated, there are the prospects for extension mentioned, but the proposals are issues which concern the Ministerial Council. As I said, my idea is for us to expand to the African sector, to the socialist and non-aligned countries."

According to our information, the appointment of an ambassador to Athens is not going to happen now, but only 2 or 3 months from now, as is also true in the case of Great Britain.

The Ministerial Council, which has studied the matter in conjunction with the other shifts which have been made, did not arrive at any decision despite the fact that there was an exchange of views and various positions were voiced.

According to our reports, the charges by Matsis, a deputy of the Democratic Rally, that in various of our embassies relations among the staff members are not good and that there have been confrontations among them have had to do with the embassies of Rome and Mexico. In one case the ambassador gave various excuses for leaving stranded the Cypriot parliamentary delegation which was on an official visit to the country where he had been assigned, and from an investigation which was made it was found that these excuses were indefensible.

In any case, the House of Representatives has found that in recent years the development of the diplomatic service has headed in the proper direction, and indeed the AKEL deputy Savvidis stressed the need for the press attaches to the embassies to be guided and supervised by the Ministry of Foreign Affairs.

"Because the appropriate ministry, the Ministry to the President, is unable with the composition which it has to do this work for people who are located far away. The Ministry of Foreign Affairs can do this by means of its ambassadors."

12114

CSO: 3521/409

## SURPRISE HIGHER RANKS POLICE PROMOTIONS ANNOUNCED

Nicosia O AGON in Greek 30 Jul 83 p 1

[Text] Ten higher-ranking officers of the police force were promoted to higher positions within the framework of the changes and reorganizations now being made. The promotions were announced yesterday morning by Chief of Police Savvas Andoniou to the parties concerned, in a special meeting which he had with them at the Police Headquarters.

According to our reports, Andoniou did not rule out the possibility of transferring those promoted to more important positions in the police force, given that many higher-ranking officers are going to be retired within a period of 2 or 3 months. To some of these he has already made it clearly understood that their transfer is a matter of days.

Georgios Patsalidis, who was promoted to the position of chief superintendent, is definitely taking on the job of Limassol police chief. Patsalidis is taking over this police directorate within the next few days, given that his transfer has already been decided on.

The other nine officers, who have been promoted to the position of superintendent A, are:

Neofytos Sofokleous: He held the position of head of the Nicosia traffic police.

Giannis Adratziotis: Head of the Criminal Investigation Department of the city and district of Nicosia.

Andreas Trifyllis: Assistant chief of the Central Intelligence Service.

Dimos Zenios: Assistant police chief of Limassol.

Andreas Artymatas: Head of the Port Police.

Khrystanthos Oikonomidis: Famagusta police chief.

Andreas Khaviaras: Morfou police chief.

Kostas Kleanthous: At Police Headquarters.

Andreas Moustakas: Officer in charge of the Nicosia city and suburbs police.

Following the departure of Georgios Patsalidis from the position of head of the Aliens Department, it is not impossible that one of those who have been promoted will be transferred to this post.

The new promotions were made abruptly, at a time when nobody expected them, and many people have characterized the way in which they were made as the most fitting, because nobody was given the opportunity to interfere.

In any case, when they were summoned to the Police Headquarters none of those promoted were expecting to be informed of such welcome news.

12114

CSO: 3521/409

## CONCERN EXPRESSED OVER TURKISH PROPAGANDA PROGRESS

## Enlightenment Activities

Nicosia O FILELEVTHEROS in Greek 31 Jul 83 p 3

[Text] If someone were to assert that nothing has been done in the area of enlightenment activities, he would be repudiated. A number of things have been done, and often the results have been striking. But at the same time we ought to observe that: In comparison with the coordinated propaganda machinery of Ankara we have not done as much as we should have--although in saying this we do not, of course, underrate the means which Ankara has at its disposal and the levers which it can move--because of conflicting interests.

For us the problem at this time is not a matter of ascribing blame or of criticism. The point is that we should get reorganized and coordinate our enlightenment effort abroad, with special emphasis at all times on those centers where the formation of public opinion or of decisions by organizations and agencies proves to be decisive for the Cyprus question. This is a matter of assessment, and it is not difficult to determine the framework within which we will have to direct our enlightenment effort.

What is important is that we be as adequate to the task as possible and above all be more persuasive. Especially with respect to our influence on certain centers which constitute contributing factors in the formation of positions and in the making of political decisions with respect to the Cyprus question. There is no other way for us to become deterrents against the escalating and more coordinated Turkish propaganda, which--let us be honest and realistic--is bearing fruit and is leading to situations which are undesirable for us. Situations with discernible consequences with respect to further developments.

Certain phenomena are fairly characteristic of the efforts of the Turkish side. And we should neither overlook nor underestimate them. For example, the development of economic, tourist, and other activities of a similar nature by private organizations or even organizations having a governmental structure, some of which are making investments in the occupied areas, or have begun a broad range of business dealings.

Everything which is being done in this direction has its political consequences. Positive for the Turks and definitely negative for us. And the worst is not what is being achieved now. The worst thing is how in the course of time prospects are taking shape which will have more appreciable and consequently more disagreeable results, if we cannot counteract this effective Turkish propaganda which is infiltrating wherever it finds an opportunity and congenial soil.

Perhaps the most disquieting things are happening in the Arab countries--in particular wherever there exists a strong Islamic base and Islamic structures generally--and in the EEC, where a certain "pro-Turkish lobby" has already been created. And this is the most serious problem at this time, because Turkey has always had political supporters in the primary decision-making centers of West Europe, which is the origin of the succession of recent visits by Eurodeputies, as well as the invitation from the same "lobby" to Denktas to visit Brussels and Strasbourg.

All of these things--and there are even more--must not simply make us concerned. They must rouse us to making effective decisions having to do with some kind of dissuasive enlightenment. An enlightenment which should be made as effective as possible in its objectives precisely where it needs to be such.

The assuming of special responsibilities by the new governmental representative for enlightenment activity is an auspicious event, given the great experience of Khristofidis in this direction. Experience and qualifications which he is offering to turn to good account. And of course an evaluation of means available and the organizing of mechanisms are needed--something which ought to be realized as soon as possible. This enlightenment is a key focus for our struggle at this moment, in every respect.

#### Hollandair Flights

Nicosia O FILELEVETHEROS in Greek 26 Jul 83 p 3

[Text] Reports that the Netherlands airline company Hollandair will begin conducting flights from Europe to the occupied airport at Tymvou not only must not be underrated, but also ought to worry us, to make us reflect, and to mobilize us for dissuasive actions.

And we must not underrate it because: This is the result of successful Turkish activity in the West European sector. Of an activity which is being extended and developed on every level, so that this "State" can bring nearer the shackles of non-recognition, and at the same time so that it can acquire economic accesses and opportunities.

The government ought to mobilize the diplomatic service more effectively and at the same time take drastic measures in order to enlighten and persuade foreign organizations to avoid becoming instruments of the fabrication created by Denktas. And perhaps the most effective way to do this is that of direct contacts with the governments concerned.

## POSITION OF PARTIES FOR ELECTION IN HESSE

Frankfurter/Main FRANKFURTER RUNDSCHAU in German 1 Aug 83 p 3

[Article by Jochen Siemens, Wiesbaden: "Nobody Dares to Make a Definite Prediction on the Hesse Election; Differing Public Opinion Polls Support Optimism Within Both SPD and CDU"]

[Text] The attitude of the Land chairman of the Hessian CDU, Walter Wallmann, is just the same as that of former national coach Sepp Herberger, who enriched the philosophy of soccer with the dictum that a game is over "only after 90 minutes." "Election results are not certain until the evening of the election," he informed his party at the national party congress at the end of May, when he also delineated the scope of sentiment for the CDU in Hesse for the coming months: "We have good election chances. But any statement beyond this would be presumptuous."

In fact the sentiment, the political atmosphere in Hesse between the two Landtag [Land parliament] elections of 26 September 1982 and 25 September 1983, has thoroughly changed. A year ago the Union [CDU/CSU] was floating--with a sometimes obtrusive unpretentiousness--on a light, white summer cloudlet of confidence in victory. Bons mots such as "Alfred Dregger is riding toward power in a Pullman car" circulated in Wiesbaden, while Minister-president Holger Boerner, visibly unnerved at the daily studies by the press, was on the lookout for new ill tidings of the breakup of the social-liberal alliance in Bonn. No, even for Social Democrats with labored optimism it seemed a foregone conclusion at that time that the "homeland of the socialists" would go to Alfred Dregger in his fourth attempt, especially since the FDP had declared itself for the Union, at the price of splitting the coalition.

When the light, white cloudlet suddenly thickened, then discharged itself and dissipated in an air-clearing storm, the Union in Hesse rudely crashed to the earth of reality. Some 52 seats, four too few. The strongest party, certainly, and therefore the winner, but not in a position to form a government, because its FDP alliance partner had been held at 3.5 percent by the lightning-stroke in Bonn.

The election returns must have seemed to Holger Boerner and his Social Democrats like the first breath of air to a rescued drowning man. Some 49 seats, accordingly the loser, but definitely shored up by the Hessian Constitution, which wants to have a new minister-president elected before

it dismisses the old one. Thanks to the new Greens in the new Landtag, that was not likely. Reason enough for Boerner to declare on the spur of the moment: "I can cope with any situation."

This confidence could not fare well over an entire legislative period. It is true that constitutional lawyers confirmed that it was possible to govern in a caretaker capacity for 4 years, and the CDU eventually abandoned its repeatedly threatened constitutional court action, but in practice--after 9 months of caretaker land government--the air has gone out of this setup. When on Tuesday the parliament dissolved itself for the first time in the history of this Federal Land, that too is an expression of the awareness of this on the part of the caretaker minister-president. "I have to put up with this constitutional obligation," he said, "and this does not correspond to my understanding of democracy. It is the most uncomfortable situation I have experienced in my life." The fact that he will be tolerating it until the autumn and is "hibernating through the summer in the State chancellery," as the opposition charges against him, has very little to do with Land politics, but almost everything to do with the general political climate.

A comparison with the 1950's suggests itself. Not only because in Bonn Helmut Kohl feels like the descendant of Konrad Adenauer, but also because of the role which the SPD is assuming in Wiesbaden. "Hesse in the foreground"--the slogan with which Georg August Zinn took a stand against the CDU in Bonn--is now being pepped up for the 1983 election campaign with the little word "again" and is being accompanied by the challenge to the voters to "clear the air." What is meant by this is a governing alone by the SPD, which will act as a "counterweight to the conservative-reactionary Federal Government," as Boerner says.

For him, much is bound up in this strategy. In such a case there would be an end to the experience--a painful one from his point of view--of having to show consideration for a coalition partner. In the last 10 months, Boerner has seen a ray of hope here as to how one could engage in "a truly Social-democratic policy." A policy free from the partner's scolding of "you talk in one way, and your policy is otherwise." Also there would be an end to the deference to Bonn, about which Boerner thinks with "bitterness."

There is now an end to such "bitterness," to the feeling that "the spearheads against the minister-president are being whittled out in his own camp." In Bonn the conservatives are governing, and his own party is seen to be enjoying a rare unity. Even the Young Socialists are not sparing with strokes for the man who just a year ago was being pilloried as the "roof-lath Boerner with his policy of nuclear and concrete construction."

After the new elections Boerner hopes there will be two parties in the Landtag, and there are plenty of hints--which, however, he does not put in more concrete terms--that he is not available again for a coalition government. A public opinion poll commissioned by the SPD itself shifts into the realm of the possible the vision of the majority which presently

preoccupies the Social Democrats. The CDU and SPD neck and neck, with the odds going to the Union, the FDP clearly out of the running, and the Greens with their 6 to 7 percent are closer to the magic number five than even a year ago.

Challenger Walter Wallmann assesses the situation quite differently. "My election goal is a coalition government," says the Frankfurt mayor, fully realizing that "only under very favorable conditions can one hope for an absolute majority in Hesse." Moreover, he says, one owes it to the FDP to reproduce the change in Bonn in Wiesbaden as well. There is also a public opinion poll supportive of these designs. With 48 percent, the Union is clearly ahead of the SPD with its 39.5 percent, and the Greens with their 8 percent. Although likewise the FDP with 3.5 percent is clearly below the limit for entering parliament, nevertheless according to the CDU poll some 41 percent of those questioned believe that the FDP will return to the Landtag.

Wallmann's open interceding for the FDP, which occasionally borders on an election recommendation, is not shared, it seems, by the general secretary of the Union in Hesse, Manfred Kanther. This person, who for the most part does not waste any words on the FDP, once let slip the rather frightened exclamation: "What must not happen in any case is for the voter to stand in the polling booth and search for his second vote." Vote splitting as is practiced by CDU voters in the Bundestag election is impossible in Hesse, with only one vote to be cast.

But what is even more likely to cause worry to the new top man is the fact that his party is now governing in Bonn and that he, Wallmann, must absorb the shocks of the consequences in the Hessian election campaign. Thanks to his direct line to Chancellor Kohl, so far this has worked out. Within a space of 24 hours, the governmental philosophizing out loud a few weeks ago about a higher retirement age for women was withdrawn from circulation, not least because of a sharp protest from the CDU in Hesse. But the openings in the social net remain, the changes in the criminal law on demonstrations are a settled matter, the budget debate is approaching, the Federal interior minister is named Zimmermann, and the solo attempts at Ostpolitik from the clandestine capital of Munich are bewildering friend and foe alike. Indeed, Boerner views the coalition in Bonn as "already as much at odds as the old one was after 13 years."

The Federal Government is committing its "atrocities" at the beginning of its period of office, and this is falling within the time of the Hessian election campaign. Within the CDU and in the Hessian Landtag, strategies are being negotiated which write off Hesse in the intermediate-term planning of the Union. North Rhine-Westphalia in 1984, yes, the national plan can also be focused on that, it is said. Quite a few people carry such considerations to the heights of political philosophy: For the sake of the whole, in the end the SPD must also govern somewhere. What is more natural in this connection than the SPD's homeland of Hesse?

No wonder that with the basic conditions having such a significance, from 6 March almost up to the summer holidays the politics in this Land revolved primarily around the date of the new elections. The Union wanted to continue to ride its wave of success, and according to Land party whip Giani, the SPD had to "keep its head and remove distortion from the elections."

In the Land's politics, on both sides the auxiliary argument concerning the budget served as a scapegoat for fixing the election date. Boerner without a budget--that was the most pointed way to show him the parliament's lack of confidence. Yet the Greens, who along with the CDU rejected the budget, were not prepared to agree to dissolve the Landtag as well. Instead they repeatedly called on the SPD to join them in submitting a new budget.

But the short phase of socialist-Green cooperation--which had led to a partial budget which the government was able to use to administer the Land and moreover to begin a jobs and environmental-protection initiative which had much publicity appeal--was long past. The SPD wants to talk to the Greens again only after the elections, if it is really necessary. "Wallmann will never hear of us in association with the Greens," Giani says, thereby keeping open a backdoor.

In any case, the "truly Social-democratic policy" which the party members are now so infatuated with has not been practiced in the Land in past months, but in the Bundesrat, in connection with numerous bills which have been initiated. Leaded-gasoline law, sulfur-emissions law, early retirement pensions, and increases in the mileage allowance and the tax-free allowance are the labels given to some of these attempts, which give an idea of what the SPD would like to do if it could. "Jobs and the environment" is the term for the platform, is the term for the mainstays of the SPD's new Hessian policy, which is to bring back into the SPD a portion of those voting for the Greens in September 1982 and at the same time is to hold on to the community of skilled workers. The Union contrasts the "new orientation" of the SPD, called "vacillating" by the CDU, with the stability of its own program. Being adhered to are two more nuclear power plants in Hesse, the construction of the freeway, and needed major technical projects.

After 25 September, after the new elections, will Hesse under Boerner become the SPD's bulwark against the conjured-up "Black Republic"? Will success-spoiled Wallmann pull off that which was denied to Dregger? Or will there be a situation with respect to the parties in the Landtag similar to what is now leading to its dissolution? This third version is made more likely by the fact that strikingly little is being said about it. Will the nuclear missiles characterize the election campaign, or will it be shocking reports from the German forests? After the election experiences of 1982, all politicians are shying away from any predictions for 1983. Herberger is right after all: A game is 90 minutes long.

12114

CSO: 3620/417

## EUROPEAN INDEPENDENCE MOVEMENT PRE-ELECTION MANIFESTO

Paris LE MONDE in French 27 Jul 83 p 7

[Text] The European Independence Movement [MIE] was founded in 1969. Two RPR [Rally for the Republic Party] deputies, Georges Gorse and Olivier Guichard, served respectively as its first and second leaders. Since June of this year the party has been headed by Mr Andre Fanton, former minister, former deputy, and an adviser to Mr Chirac on communications problems in the office of the party president. The party's general delegate is still Mr Alain Ravennes. The nine-member directorate, which includes only opposition members, is composed of RPR deputies Messmer, Guichard and Cointat; the RPR's Senator Schumann; former UDF [French Democratic Union] deputies Chinaud, Bettencourt, Granet and Achille-Fould, and Trabuc, the inspector of finances.

The manifesto published below, which the Movement's directorate has just adopted, is the first joint communique issued by both opposition groupings in preparation for the European elections of June 1984. The RPR acting alone already adopted a fairly similar position at its central committee meeting of 12 June. The UDF, which has announced it is opposed to a single opposition list, has established a special commission, which has not yet met (LE MONDE of 9 July).

The MIE in 1979 declared itself in favor of a single list for the then-majority. Harshly critical of government's performance, the manifesto expresses the fear that the European Community is in a state of "regressive evolution."

Do people still want Europe?

The language of official pronouncements and the silence of the government indicate that the answer is clearly: No, people do not want Europe anymore.

However, when these same people were in the opposition, the word "Europe" was constantly on their lips and pens: it was one of those magic formulas by means of which they claimed to be able to bring progress to France and happiness to the French people.

And, too, the French people themselves remain convinced that Europe is useful.

The heads of industry, farmers, economic officials know that under the conditions of economic warfare that have existed worldwide since the end of 1973 France cannot remain isolated, and Europe is indispensable to our development.

As for wage earners, they ought to know that the future of their jobs, their standard of living and their security is directly tied to the condition of the European economy.

While the government involves itself everywhere around the world in the name of some vague doctrine, the French people have begun to realize--with concern the bitterness--that their country is no longer one of the leading powers of Europe, but is less and less listened to and respected.

Since the government is unwilling to do it, it is necessary for other men, other forces to think about France's position in Europe, to reflect on the present situation and future possibilities, to take action. In launching the new campaign of the MIE our aim is to help fill this gap.

Europe and its Independence Threatened

Our movement was established in 1969 in order to uphold and support something necessary: the independence of Europe. Independence for the [European] peoples is above all else the way to preserve their liberty, the freedom of the individuals that compose them, and responsibility for their decisions.

Our demand remains the same: an independent Europe.

But, since 1969, the world has changed, and so have conditions, the balance of forces, and the seriousness and urgency of the dangers.

In assessing the dangers, there can be no comparison between threats to mere interests--however, important and legitimate they may be--and threats pointed directly at what is most important of all, namely freedom.

In the past we have denounced that excessively accommodationist spirit in which a self-abasing Europe has abandoned itself to American protection and American hegemony.

We said back then that Europe had the possibility and the obligation to assert its own identity in the face of the monetary, financial and technological domination of the United States, thereby avoiding the need to entrust our security entirely to the U.S. nuclear umbrella, which is both costly and uncertain.

Were we wrong or were we right? The experience of nations that have gambled their political fate on American support inclines us to think we were right.

But now it is 1983. People everywhere are coming to see clearly and with a sense of alarm one fundamental fact: the world and Europe are threatened first of all and above all by Soviet totalitarianism. The Soviet totalitarian system, in fact has reversed the balance of power and made itself the number one military power in the world; it has increased its military superiority in Europe; it keeps all its "allies" under an iron yoke, while constantly finding new ways to infiltrate the countries that are still free and exert influence and pressure on them. It is constantly engaged in the political, psychological and moral destabilization of the free societies, it plays on all the "weaknesses" inherent in the virtues of democracy, while offering nothing in exchange except paper promises.

The Soviet Union makes itself felt in a thousand ways in the Western world, and despite the failure of Soviet totalitarianism, it has continued to make political gains.

In 1973, the MIE warned the public in the report of its general delegate, entitled "Europe in Danger of Peace." It issued many warnings against an overly hasty signing of a pseudo-accord on security and cooperation, maintaining that there was too great a risk that the word "cooperation" would be used to benefit only one side.

The first and vital responsibility of Europeans is to be determined to maintain peace without ceding any of their freedom. Our first task will be to remind them ceaselessly of this, to keep them on the alert for disinformation and committed to the cause, even in the face of illusory or manipulated "pacifist" campaigns.

#### Real Europe in Decline Since 1981

From this point of view, the positions taken by the head of state may merit encouragement and support. Two serious ambiguities characterize them, however: the determination at all costs to distinguish so-called North-South issues from so-called East-West issues, as if it were not all one world, and as if the aim of totalitarianism were not one. Revolutionary "Third-Worldism" is a fallback ideology for communism; the fact that "socialist France" not only endorses but supports it is a serious matter; and, above all, the participation in the government of ministers who are members of a party that has fraternal ties to the Soviet Communist Party is more than an ambiguity: it is an incoherency and a serious vulnerability.

Finally, [the government's] affirmation of Western solidarity is good. Active and responsible participation in maintaining that solidarity would be even better! The decline of the national defense budget is a subject of serious concern--and on this point the original concept of the MIE shows its true value and realism: the values of freedom would be better protected by an alliance between American power and European power than by American power and European impotence.

Every time people have dreamed of building Europe on abstract visions of the future, the enterprise has failed. Every time efforts have been made to build it on realities, there has been progress.

In that regard, what could be more contemptible than those so-called "socialist" summits which substitute the irresponsibility of parties for the responsibility of statesmen?

This has been one of the signal achievements of the Fifth Republic: having inherited a situation that rendered France incapable of embracing Europe, it took the portentous step of opening up the European market and, along with its partners, undertaking the building of the [European] community.

The Europe of the community is only partly built: it is incomplete and unfinished. But it does have some essential worth--it exists, and it can show the peoples that compose it, including our own, a clearly positive record of economic and humanitarian progress.

Much of Europe remains to be created. We will speak about that, we will have proposals to make. But first of all we must safeguard a community which everyone can feel is threatened.

What is the real Europe? It is the Europe that takes into account the vital national interests of the member states, while striving to transcend archaic egoisms. It is the Europe that supports social progress on a solid economic foundation. It is thus a Europe which assumes a generally shared conception of the economy and society.

That is where the shoe started pinching in the spring of 1981. By carrying out a demagogic, irresponsible, anachronistic policy of recovery through consumption, increased deficits and debt, France departed from the path of reason and reform being followed by its partners; now, conversely, the brutal austerity policy to which those earlier mistakes have led puts France out of step with the movement toward recovery which is just beginning and which is expected to gather momentum among its Western and European partners.

Already, here and now, the size of France's domestic and external debt service, a part of which is unknown and incapable of being monitored, limits France's freedom and capacity to act. A European France requires first of all a coherent and responsible France.

And that is where the shoe pinches hardest. The Europe of the community could not be built, could not succeed, unless the governments of which it is composed, regardless of their differences, shared a commitment to the same basic vision of the economy and the same ideal of a free and responsible society. Such a commitment--to put it as mildly as possible--is not the strong point of the current government.

The weight of evidence, sad to say, is that the EEC is on the road to decline. It is weakening and fraying. The three great principles of the Common Market--free movement of goods, people and capita; community preferentiality, and financial solidarity--are no longer or not at all respected.

The community budget is becoming a mere compilation of individual national programs. Only the agricultural policy, which has remained a common policy for a quarter of a century, is resisting this retrograde movement, but it, too, is under constant attack. No really new community action is envisaged and if in 1984 Europe's "own resources" are exhausted, agriculture will suffer most from that generalized recession. One is justified in fearing the worst, especially since starting this year five member states (Great Britain, the FRG, Ireland, Italy and Greece), proponents of a "fair return," will get Community subsidies that are not justified by any treaty.

#### Stop the Regression of Europe

The French Government, locked into its own ideology, regrettably lacking in commitment or constructive proposals, must bear a large share of the responsibility for Europe's regressive evolution.

The truth must be told: the EEC is in danger of dying a lingering death and evolving into nothing more than a vague free-trade zone bereft of political or economic significance.

For the first time in the history of the EEC, a government--alas, it is our own!--is practicing a policy that rejects the principles on which both Europe's success and hopes were based. And for the first time a government has included the communist party. Nationalizations, statification, political syndicalism, attacks on the entrepreneurial and responsible forces in society, and the substitution of class resentment for appeals to effort and initiative on the part of all have distinguished the first years of the socialist septennate, isolating France from a Europe to which previously it had greatly contributed. At the halfway point, "French socialism" is hesitant and groping. It is in danger of surrendering to the temptation of protectionism, a move which would complete the disaster.

Already France's isolation is that of a country that is on the dole and therefore kept under close surveillance. The incoherence of the socialists gives us even greater reason to fear a rupture between France and Europe. We would be completely and resolutely opposed to that.

More than ever we want a European Europe, an independent Europe, closely allied with the Western world to safeguard the most basic values everywhere in the world. We want to see a Europe of free and responsible individuals.

To bring that about, we want to see our own country responsible and proud. It should not make others bear the burden of its own mistakes and deficiencies, for this would undo the long and still incomplete work of reconciliation, of achieving that broader understanding and sense of brotherhood which Europe has meant.

We want, therefore, to see the real Europe reawaken and move forward, as we wish to see France once again become a real France.

(European Independence Movement, 30, Rue Saint-Dominique, 75007 Paris.  
Tel.: 550-23-83.)

9516

CSO: 3519/585

## GALLOIS ON DISARMAMENT NEGOTIATIONS, U.S., SOVIET STRENGTH

Paris POLITIQUE INTERNATIONALE in French Summer 83 pp 221-237

[Article by Air Force General (Ret) Pierre-Marie Gallois: Boy-Scouting and the KGB--Reflections on the Ingenuousness of the Westerners." General Gallois was assigned to the interallied headquarters, where he worked on the long-term strategic plans. He is the author of, among other publications: "La strategie de l'age nucleaire" (The Strategy of the Nuclear Age), Calmann-Levy, 1960; "Paradoxes de la paix" (Paradoxes of Peace), Presses du Temps Present, 1967; "L'Europe change de maitre" (Europe Changes Master), Ed. de l'Herne, 1972; "La grande berne (The Great Blanket-Toss), Plon, 1976; "L'adieu aux armees" (Farewell to the Armed Forces), Albin Michel, 1976; "Le renoncement" (The Renunciation), Plon, 1977.]

[Text] The question arises. Why, for at least a quarter of a century, have the great leaders of the Western countries often shown themselves incapable of conducting the affairs of the world to the advantage of their peoples? Is the Soviet Union's accession to power and domination due more to the efficiency of the system--at least in the matter of territorial expansion--and to the political science of its leaders than to the shortcomings of their opposite numbers who exercise the same responsibilities?

From the Cuba confrontation in 1962 to the affair of the Euromissiles 20 years later, and between these two matters, the erroneous interpretation of "peaceful coexistence" according to Mr Khrushchev, the dramatic events of Southeast Asia, the acceleration of the strategic-armaments race after SALT I, the uncontrolled and thoughtlessly accepted increase in the price of energy, the monetary disorder, the hopes based on the Helsinki agreements, the discomfiture of the United States in Iran, the vain SALT II negotiations, the American procrastination in the matter of military programs, the pitiful handling of the question of enhanced-radiation weapons, and more recently, the evocation of the distant possibilities for mastery of space, so as to quell the anxieties of today with the technologies of the day after tomorrow (while at the same time starting up a new and dangerous competition in the cosmos again)--what errors of evaluation, of unfounded speculations, of peremptory assertions immediately impugned, of disappointed illusions! What political and moral defeats!

How is it possible that so many people chosen from among the most eminent, surrounded by the best experts in their various disciplines, with the means

of investigation and analysis that science makes available to them, have been able to go so far astray? With the most highly perfected means of information, explanation and even persuasion available to them, how have they arrived at such a split between the political behavior that they adopt and the sentiments of the populations whom they desire to serve?

The Federal Republic of Germany, the No 1 Target of the SS-20's

It was Chancellor Schmidt who, on 28 October 1977, initiated the affair of the Euromissiles. Speaking to the International Institute of Strategic Studies of London, Mr Schmidt referred to the "imbalance" of the armed forces present in Europe and urged, in substance, that "at all levels," a certain "parity" be reestablished. It is true that at the time, the Soviets were working on "modernization" of the ballistic missiles trained on West Europe and that they were simultaneously strengthening their conventional forces.

The German general staff had doubtlessly alerted the chancellor to the un-stoppable threat that the deployment of new, precise ballistic weapons by the Russians brought to bear against the whole of the conventional military apparatus of the FRG in particular, and against the air-land contingents of the European countries of NATO in general. Chancellor Schmidt's appeal was addressed to the United States. It was heard, and President Carter proposed to give to the allies weapons more modest than those of the Russians but nevertheless quite similar, and in addition, a supplementary physical "recommitment," since specialists from the United States were to get this new weaponry into operational status.

All these dealings were carried on at the level of the governments and the general staffs without concern for the reactions of European public opinion, with no consideration of the geographic and demographic asymmetry that enables the Soviets to move mobile nuclear missiles over vast inhabited spaces but that prevents the Western leaders from doing the same thing in territories with high population density. None of the political leaders of West Europe was able to explain the reasons for Chancellor Schmidt's initiative, still less demonstrate the interest of President Carter's offer. These leaders doubtlessly did not themselves understand the significance of this form of American recommitment and the increase in security that it would provide to Europe.

The German High Command had had good reasons for manifesting its uneasiness. It was already true in 1977 that the new ballistic weapons--or the flying weapons, such as the cruise missiles--were achieving very high precision, that this precision was increasing steadily, gradually eliminating the firing deviations, even though the targets aimed at were at considerable distances, measured in thousands of kilometers. Thus the destructive energy carried by these new weapons was gradually reduced so as to be suited just to the size and resistive strength of the objectives, with firing error almost nil. Megatons gave way to kilotons of nuclear explosive, which in turn are now being replaced by atomic warheads in the low range (1 or 2 kilotons, even 1/2 or 1/3 of a kiloton) if that is what is appropriate for the objective aimed at.

These weapons, deployed in large numbers by the Warsaw Pact forces, could easily paralyze almost the totality of the armies and air forces of the European NATO countries, and especially those of the FRG, which constitute the main part of them.

The precision of the new long-distance jet-powered weapons transcends the German and even the European case. The validity of the traditional armed forces, wherever they may be, is what is in question. It is clear that, taking advantage of the surprise-attack effect and striking simultaneously all the critical objectives of a conventional military system, with its barracks, its depots, its airfields, its radars, its command posts, the side that took the initiative in such an operation would be assured of total victory over its victim. Without losing a man, it would disarm its adversary while sparing the latter's habitat and preserving its economy, which it could then use to its advantage. Though nuclear explosives would have been used, such a form of warfare--but would it be war, since there would have been no exchange of blows?--would do far less damage than a conventional conflict pitting thousands of tanks and cannons against one another and sowing death and ruin everywhere.

#### Strategic Esotericism and Its Dangers

The leaders of the NATO countries--presumptuous, believing they could easily get their public opinion to share their own judgment--accepted President Carter's offer without taking too much trouble to make its interest understood. Thus, the populations protested, in the form of hundreds of thousands of demonstrators. "We are not inspiring these movements," say the Soviets, "but we stand solidly behind those who are animating them!" What better way to win a victory than to get the opponent to desire his own defeat? At the time, it was not the population but rather the French government that did not grasp the political and strategic significance of the new weapons that the Russians were deploying, any more than they were alarmed by the military doctrine that the Soviet High Command was announcing. It was at the time when the first SS-20's--with firing precision already ten times as great as that of the missiles that they were replacing--were being deployed that the legislative bodies passed a "military programming" law favoring armament most vulnerable to the SS-20's and their successors, to the detriment of the armament which, by its mobility and compactness, could be sheltered against strikes by them.

As fate had it, that year 1976 was for France the year of error, of pretention, of contradiction and, unfortunately, of haranguing. While public opinion and the legislative bodies were prepared to subscribe to a legislative text that was to cause the regression of a military apparatus already in a state of hibernation, official France committed a new blunder. And a big one! After reducing the national nuclear effort so as to gather together conventional forces that would bring us closer, in this area, to our German neighbor--and what a fine ambition that was when it was learned, a year later, that Chancellor Schmidt was discovering the vulnerability of his armed forces!--the government and the military command declared that they were going to "broaden to Europe and its immediate approaches" the concept of na-

tional deterrence, to replace it with the notion of "broadened sanctuarization...so as to intervene, with all or part of our forces, anywhere in the zone where the security of this territory (the national territory) might be immediately threatened--that is, schematically, Europe and its immediate approaches, including the Mediterranean basin in particular."<sup>1</sup>

The pretention was both ridiculous and dangerous. Ridiculous because governments know--and the populations have a pretty good idea--that there is a close relationship between the power of the arms that a state has and the importance of the human and material resources that it is protecting with these arms. After cutting back on nuclear power and weakening France militarily, it was laughable to want to assign it broadened responsibilities on the scale of West Europe. None of the European countries to which "sanctuarization" of this type was thus offered feels any more reassured. It is always disagreeable to see France and the manifestations of its vanity turned to derision. But this unexpected behavior was also dangerous. In the face of the power of the Soviet weapons and the determination with which Moscow puts them to use, it is hard to imagine how France would manage to get itself out of an "affair" in which it had imprudently got involved at Europe's "northern or southern approaches": our country could only capitulate shamefully, or, if it persevered in violence, bring down insupportable reprisals on its soil. And for an affair which, initially, would not have concerned it.

Eight years later, the blunder became a disaster. Mr Brezhnev and his advisers had long left the concept of "broadened deterrence" lie quietly sleeping. He preferred to it, of course, the concept of "omnidirectional defense" that General de Gaulle had prudently called for, indicating thereby that his country did not have any designated enemy but that it simply intended to be able to ensure the immunity of its soil against anyone.

But now, with the circumstances propitious, Mr Andropov is awakening the serpent that has been napping in the bosom of a blundering France. Since there is the question of Euromissiles, since the Western countries want to negotiate and are behaving as if they were terrorized by the SS-20's (whereas they accommodated themselves, for nearly a quarter of a century, to the threat leveled against them by the SS-4's and the SS-5's that the SS-20's are gradually replacing), and since the negotiations have been started and each party has to lay its cards on the table, the secretary general of the Communist Party of the Soviet Union means for the British nuclear forces (Great Britain belongs to NATO) and the French ones (for what reason?) to be included in the inventory of armaments which, like the new American missiles, can reach the territory of the empire.

On what grounds? France wants to know. All the French nuclear weapons--the tactical weapons being linked to the strategic ones, for which they are the detonator--protect only the national soil. On the scale of a medium-size power, they correspond to the Soviet ballistic missiles, which, over the Arctic, could reach the soil of the United States. Thus the French negotiators can rightly declare: "It is out of the question to figure in an accounting that would include your roughly 1,400 fixed missiles, the thousand similar missiles carried by your nuclear submarines (which themselves are 15 times

more numerous than ours), the 6,000 megatons that your rockets can launch against the 8,000 objectives they could reach. Your overarmament would again be brought out into the open, and no one on this earth would complain about our wanting to ensure the immunity of our soil by keeping operational a nuclear force that is very inferior to the hundredth part of yours." Same reasoning in London.

A fine pleading, the Russians reply, adding, for the French government in particular: "Your arguments contradict your official declarations. You have indeed said--and written--that your new doctrine of /broadened deterrence/ was intended to enable you to intervene with /all/ or part of your forces... in Europe and in its southern (and northern) approaches--that is, at the borders of the territories of the Warsaw Pact. And you would be intervening in a combat that would not directly threaten your territory but rather, in your judgment, your security in general. Thus, no comparison with our strategic forces--which, furthermore, are aimed at another continent--is not, for us, admissible. Since you have envisioned committing /all/ or part of your forces both in the countries of the Warsaw Pact and at the /southern and northern approaches to West Europe/, it is clear that your military means must figure alongside those that NATO aligns against us. We are relaxing and overlooking the short-range vectors, but we are specifying those carried by your nuclear submarines and those on the Albion Plateau. Today, 98 vectors; tomorrow, 114.<sup>2</sup> The day after tomorrow...."

#### Denouncing France

The day after tomorrow, negotiation will be still more difficult. It is very probable that at present, Mr Andropov is concerned little about the 114 strategic vectors that interdict attack and occupation of French territory. They create a risk that it is useless to run. So proceed differently. Politically, though, "broadened sanctuarization" is a godsend. While France will equip its missiles with a warhead with six nuclear warheads not separately guided toward different objectives, the same vectors could, one day, carry some 628 warheads more than 3,500 kilometers. If each of these warheads were reduced to 100 kilotons, and with precision increased, the missile would be an imposing instrument of destruction.

The Soviets will immediately use this increase in destructive power as a pretext for increasing their own by the same amount, no matter what its magnitude already is. And since the difference between the long-range--transarctic--missiles and the medium-range--trans-European--missiles is tending to disappear, it is probable that the United States in turn would not mean to be left behind and would further augment its panoply. So that despite the strategic-arms limitation agreements signed in Geneva--if they are, one day--each of the two parties will increase its arsenal. And the most defensive, the most modest, the most reasonable of the nuclear forces of deterrence would be causing a revival--certainly a limited one, by comparison with the other side--of the strategic-arms race. Unless the great powers--backed, in this case, by other powers, medium-size and small ones--heap general contumely on France and force it to renounce, at least partially, the instruments of its defense. And from "broadened deterrence" we would thus arrive at "shrunkened deterrence."

The dominant autocracy knows, from experience, that it always wins if it sticks to the "hard line." Little by little, as if by lassitude, the democracies accept the most disadvantageous compromises. They often inspire themselves. Their leaders, in quest of voters and concerned to make a show of good will, do all they can to find formulas for conciliation, even if they are contrary to the interests of the peoples for whom they have responsibility. And if, despite all the concessions, the opposing party sticks to his positions, then the West gives up and capitulates. That is the way it was in the matter of the enhanced-radiation weapons, ineptly called "neutron bombs." The United States government, the military and civilian specialists, the news media announced to the world that this revolutionary weapon--though experimented with 15 years earlier--was indispensable to the defense of Europe, that it was vital for the Europeans to have recourse to it, so as to neutralize the Soviet superiority in combat tanks. The tardy revelation of this new weaponry technique, poorly presented and poorly explained, was received poorly by the public opinion of the Western countries--and even more poorly, of course, by the leaders of the Warsaw Pact countries, who saw it as a threat against one of their established advantages: the qualitative and quantitative superiority of their armored vehicles.

On the Soviet side, it sufficed, in order to wage a campaign against the new weapon, to speculate on the esotericism of nuclear techniques, to exploit people's aversion to all the sorceries of the atom, to let the military, who wanted to get control of a new weapon and regild the escutcheon of the artillery, commit all the usual errors in psychology, and all the ingredients for failure were combined. Was it competent to explain to the populations that this new weapon would distinguish between the crews of enemy tanks, who would be exterminated, and the nearby housing, which would escape destruction? This amounted to giving it to be understood that as far as deterrence is concerned, the enemy and his tanks would indeed be occupying the national soil, since they would be in the heart of its environment. And besides, there are already in Europe--and have been for a long time--2,000 or 3,000 shells with low destructive power that can be fired by American 155-mm or 203-mm cannons, projecting mortal doses of neutrons to 375-400 meters from the site of detonation. The new shells would do "just as well" at 850 meters. Does this difference in range justify the new investments--some Fr 40 billion for fewer than 2,000 projectiles? And can it be imagined that the Soviet tanks would reach the urbanized zones of West Europe without having destroyed the habitat? Why spend so much money to preserve ruins?

It would have been sufficient to point out that the first enhanced-radiation projectiles were experimented with, nearly 20 years ago, as antimissile weapons. When Europe was under the shock of the Soviet SS-20's, accurate and unstoppable, capable of neutralizing with a single salvo all the conventional military installations of the European countries of NATO, the enhanced-radiation technique could have got through as the explosive for an antimissile defense system which, one day perhaps, would save NATO's military apparatus from paralysis and destruction. That formula would have calmed the opposition and defused the propaganda. What could be more acceptable than a purely defensive technique aimed at protecting the traditional armaments exposed to strikes from the new Soviet offensive missiles? Preference was given, over

the defensive aspect of the "neutron bomb," to its antitank "virtues," with the inevitable train of embarrassing questions raised by such use.

Thus Mr Carter had to beat a retreat and renounce the saving of Europe from the Soviet tanks. France, still presumptuous, decided to take up the matter on its own. With American technical assistance. And thus it is that the current presidency has inherited from the preceding one a "project" that is militarily uncertain, politically difficult and financially very expensive. The responsible officials, their brows knitted and eyes fixed on the blue line of the Vosges, are content to reply that they are thinking about it. Mr Brezhnev, in his day, was able to flatter himself with having scored another point. Exploiting the ineptitude of his adversaries, all he had had to do was inspire a few propagandists in order for NATO to bend and be able to deploy only the weapons that the Kremlin tolerates.

The same scenario with the Pershing II's and the Cruise missiles. Moscow does not want them. Thus the Western statesmen outdo one another in platitudes to mollify Mr Andropov. "How about if we deployed fewer of them? And what if we gave up the Pershing II's, which you decidedly do not like, and kept only the Cruise missiles, which are slower and more vulnerable, and all the less militarily significant in that your anti-aircraft defenses, as they are today, are formidably effective? You understand that in 1979 we made some commitments to our peoples, and we must at least give the appearance of keeping some of them." "Nyet," of course. In the East, they know it is sufficient to hang tough and wait.

#### A Zero with a Double Meaning

The "zero option" put forward by Mr Reagan marks a new climb-down. But it is all as if none of the leaders of West Europe had understood it. They unanimously applauded a proposal which, in the long run, condemns their countries to a sort of vassalage. Even more, it would seem that some of them have pushed ignorance to the point of urging Mr Reagan to join in it. These politicians probably did not know what this "zero option" meant, what it contained and what it left out.

What did it contain? On 18 November 1981, giving his directives to the American negotiators leaving for Geneva, President Reagan defined in this way what he called the "zero option": The United States would abandon deployment of the medium-range Pershing II's and the surface-launched Cruise missiles if the Soviet Union dismantled its SS-4, SS-5 and SS-20 missiles."

The formula was simple, of course: zero all around--that was the understanding. It struck people's imaginations, since it evoked a nil situation and implied a disarmament. It was spectacular to propose to the world to drop down, on both sides, to the threshold considered the lowest. In electoral terms, nothing could be more profitable. Mr Reagan was obeying the rules of the system that had brought him to the presidency of the United States and which he was convinced was the best. Demagogy? Perhaps. But in a democracy, can one win a people's votes without being demagogic?

And what could be more electorally successful than proposing that all the new nuclear armaments in the European theater, including those that Mr Schmidt and the leaders of the neighboring states had themselves said that the fate of Europe hangs on, be sent to the scrap heap, simultaneously and symmetrically?

As for Mr Andropov, on the other hand, he does not have to make any verbal concessions to a public opinion that is not permitted to make its feelings known.

It remains to consider the essential thing, what the "zero option" does not "contain."

--It ignores, for example, the SS-21 missiles and the Frog 7's that they are replacing. The Warsaw Pact forces have deployed 650 of them, which, with range of up to 100 kilometers, could fire some 2,500 nuclear projectiles on NATO's advance formations.

--It makes not the least reference to the 600 SS-23's, which are gradually replacing the Scuds and for which the Warsaw Pact forces would align 600 launchers capable of firing 1,200 nuclear warheads to more than 300 kilometers beyond the Iron Curtain. This means that almost all of the NATO forces deployment in the Central Europe sector are under the threat of these unstoppable missiles.

--Nor does it mention the 100 SS-22's--a modernization of the old Scaleboard missiles--which could fire 2,300 nuclear warheads to a distance of more than 1,000 kilometers.

--Finally, one looks in vain, in the definition of the "zero option" according to Mr Reagan, for the 20 missiles carried by the Soviet nuclear submarines removed by the SALT I agreements but still formidable on the scale of West Europe.

In toto, the "zero option" ignores 1,400 of the 1,935 missile launchers deployed by the Warsaw Pact forces and also 4,000 of the 5,000 warheads that those launchers could fire. In summary, it considers only 20 to 25 percent of the Warsaw Pact's ballistic arsenal. NATO, by comparison, aligns only 340 launchers, including 60 old Honest Johns that are being repatriated to the United States.

A singular "zero option," this! It is all like something out of a Volkoff-type montage: only the SS-20's have been brandished on many occasions so as to concentrate the Westerners' uneasiness on that category of armament. Mr Reagan, like Mr Carter and Mr Schmidt before him, seems indeed to be concerned only with those missiles. Without using a single one of the SS-20's, though, and because the NATO forces' deployment comprises hardly any more than 400 critical military objectives, the Warsaw Pact general staff could still, in its calculations, allocate close to 10 nuclear warheads to each of those targets. If it were not for the art of negotiation and the taste for triumph, Mr Andropov could take an easy-going posture and reduce the number

of his SS-20 batteries. But why would he consent to that, since he believes it is sufficient for him to wait: the Western leaders, anxious to reach a successful conclusion before the deadlines of the big elections, are thinking of everything they can in order to offer him new concessions.

Furthermore, Mr Andropov can see widely and far. On the soil of the vast Russia that Peter the Great cut out in Eurasia are installed some 1,400 long-range ballistic missiles. A number of them, chosen from among the oldest--100 or 200 SS-11's, perhaps--are already "allocated" to the European theater. There are two types of them: some with one nuclear warhead, and the others--more recent--with three warheads. Thus it is impossible to know how many objectives these SS-11's could hold under their threat. It goes without saying that the "zero option" does not take these missiles into account, if only because they already figure in the balance-sheet of those that could reach the territory of the United States. With technical progress helping, it may be supposed that some day (relatively soon) the precision of these long-range missiles will be high enough for low-energy nuclear warheads to be substituted for the ones with which they are fitted today. If, by using a triple guidance system (inertial, stellar sighting, radar correlation), the American technicians hope to achieve, at a distance of more than 10,000 km, target deviations of less than 100 meters--that is, practically eliminating target errors in relation to the center of the target--it is probable that their Soviet counterparts will prove just as capable. And then there will be hardly any difference between the transarctic missile aimed at the United States and the trans-Eurasian missile aimed toward West Europe or China, so that, SS-20's or not, West Europe, for its part, will long find itself under the unstoppable threat of the Soviet ballistic missiles, no matter what their emplacement or their maximum range. With its roughly 300 SS-18 missiles with at least 10 warheads, a like number of SS-19's with six warheads, and a thousand missiles on board its submarines, the Soviet Union hold the United States in check. And it still has 500 SS-11's and nearly 200 SS-17's for coping with other eventualities, including what might arise in the West.

This means that so long as the ballistic missiles of the two great powers mutually neutralize one another, the rest of the world, and especially Europe in the west, India to the south and China to the southeast, will remain under the potential threat of several thousand nuclear warheads with different levels of destructive energy.

In view of these outlooks, the "zero option" cuts a sorry figure. Thus it is surprising that all the Western leaders have subscribed to it.

The "zero option," kept within the limits drawn for it by Mr Reagan, does not reestablish--far from it--the Eurostrategic balance that Chancellor Schmidt had sought. Is it, then, just a political artifice, deprived of military significance? Might Mr Reagan have put forward this "zero option" only to free the United States from a supplementary guarantee, perhaps imprudently given to Europe by his predecessor? Or did the president of the United States think that he could bet, without risk, on a rejection by the Soviets? Vis-a-vis world public opinion, he would then, as in the negotiations, have been the star of the show.

But Mr Andropov has come out of it well. Though he has offered to consider a certain reduction in the number of SS-20 batteries--an excessive number of which are already deployed, if it is kept in mind that the SS-20's are considered to be replacing the SS-4's and the SS-5's<sup>3</sup>--he has largely compensated for this apparent concession by including the French and British nuclear forces in the negotiation. In addition, concentrating attention on the SS-20's alone, he knows that he will not be reproached for either the SS-21's or the SS-22's or the SS-23's, or, obviously, the SS-11's and other long-range missiles.

#### The Rage to Negotiate

It is obviously necessary for the Western leaders to look good from time to time and for them to offer their voters a few apparent diplomatic successes. Thus it is that in view of the Soviet "nyet," and after warmly accepting it, they have come to condemn the "zero option," which they judge--after reflection--to be too rigid. Some propose that an understanding be reached at a "lower level," and others grant the Soviets the privilege of numerical superiority. Don't they have two "fronts" to hold? Still others appear to hope that the Americans will gradually deploy their new missiles so as to hold a trump card in the negotiation. This proposal would make some sense if the Westerners had not fixed a ceiling on their operation in advance--572 Pershing II and Cruise missiles--whereas the Soviets have been careful not to make known the number of SS-20's they mean to have at their disposal.

And why negotiate? What benefit can the West derive from the Geneva talks? It is not the American specialists' argumentation that will determine the number of SS-20's finally decided on, but rather the number of objectives that the Soviet general staff intends to hold under possible threat. Or, on the psychological level, the intimidation effect that the show of an imposing arsenal can produce. There is already a saturation as far as the European western isthmus is concerned. There are very probably more SS-20 warheads than there are objectives to attack. As for the disarray created in the Western camp by the appearance of these missiles, it is manifest. The SS-20's have therefore played their role. Negotiating a limitation or reduction of the Soviet operational batteries would necessarily impose concessions for which only the West would pay the price. In 1931, Dimitri Manuilsky, remote predecessor of Suslov, wrote: "In order to win victory, we must use surprise. We shall begin by animating the most theatrical of peace movements. We shall make spectacular proposals and even spectacular concessions. The capitalist countries, stupid and decadent, are working toward their own destruction. They will solicit our friendship, and when they have lowered their guard, we shall crush them with our fist." These predictions are half a century old. Today, it seems that the fist has become superfluous.

#### Mobilizing Space

To general surprise, and while Washington is intending to negotiate in Geneva, Mr Reagan leaps beyond the contemporary. He proposes to his fellow citizens that they work, starting today, toward tomorrows in which America, possessing mastery of space, would impose a state of nonwar on its powerful rival by replacing threat of reprisal with defense.

The idea is a grandiose one. The current state of technology opens up such prospects and effectively makes it possible to envision destruction of the aggressor's weapons from a remote distance, at the moment when they would come to be used. This project will doubtlessly be achievable toward the end of the century, or at the beginning of the following one, as President Reagan has given it to be understood.

But what questions arise! Would the Soviets accept such mastery of space above their territory? And would they agree to the offer that would be made to them to organize jointly a defense system in space that would substitute for nonwar by "mutual assured destruction" of the big belligerents the mutual assured destruction of their strategic weapons? It is all the more doubtful in that the initiative is from the American side. And is a 100-percent effective defensive system even conceivable? All the more so because the stakes are considerable--vital, even--and because just a few nuclear projectiles could cause intolerable damage. If, as a precaution, the two powers were to retain their vast panoply of missiles and bombers, wouldn't there be two arms races--the present one and the one that would result from the space rivalry? Or, in order to saturate the new defensive system, wouldn't one of the two powers, or both of them simultaneously, be tempted to increase the number of their strategic weapons even further? In the multipolar world of tomorrow, will other states--vast, heavily populated, powerful in their way--be able to accommodate themselves to such control? This kind of unilateral control of space--rather, bilateral, competitive or complementary control--leads to a form of hegemony that the rest of the world might very well not tolerate, even if its aim is to impose a state of nonwar between the two superpowers.

Why proclaim, now, this singular view of the future? It is not certain that public opinion understands the purely defensive function of the proposal. Thus President Reagan once again runs the risk of being accused of speeding up the arms race at the very moment when, by numerous declarations--and a few spectacular concessions--he is stating the desire to brake it.

In reality, it is the concatenation of a number of errors in judgment, of gratuitous renunciations, of inept demands, that has led the president of the United States to speculate on the magic of technology, the miracles of the cosmos and the solid belief of America's citizens in their technological superiority, to attempt to stop the uncontrolled skid that the West has gone into.

Today, in fact, one learns that the American strategic bombers being taken into account in the Geneva negotiations are "older" than their pilots; that the Russians have launched some 60 missile-launching nuclear submarines in the same time that the United States put only one out to sea; that the Soviet Army could muster 54,000 tanks, while the U.S. Army has only one-fifth as many; and finally, that the USSR produced 13,000 artillery pieces and rocket-launching batteries in 9 years while the corresponding figure for the United States was 950! These comparisons would hardly have any meaning if they did not illustrate two different strategies and if they did not bring out two opposing modes of political and social behavior. Thus, upon his arrival in the

White House, Mr Reagan was confronted with a sobering situation. . Could he have reacted otherwise than he has , even at the risk of asking the voters to subscribe to a policy opposite to that to which his predecessors had accustomed them? One understands the difficulties of such an approach. The system has its inherent advantages and weaknesses: during Mr Brezhnev's reign alone, the United States had five presidents. After taking over his predecessors' programs--programs regularly contested, always delayed, aged by the permanent state of proposal in which the administration kept them--Reagan doubtlessly wanted to paralyze this permanent opposition by skipping over a technical stage, by substituting defense for reprisal and by taking outer space-- a source of pride and ambition for his people--as the theater for the future exploits of the American technicians.

Canrobert? Present!

In the United States, the appeal to supertechnology is never made vainly. The Americans have enthusiasm for it, they speculate on its successes for conserving their way of life, even for other peoples to appreciate its advantages. In Europe, the lag is considerable. At a time when Mr Reagan is talking about satellites and laser rays, Olof Palme, Egon Bahr and Andreas Papandreou are hugging the ground, as was done overcenturies of armed confrontations. Mr Palme proposes that a "denuclearized" geographic zone encompassing Ireland and the Scandinavian countries be created; Mr Bahr would like central West Europe (essentially the two Germanies) to be emptied of all atomic weaponry. As for Mr Papandreou, he would like the same thing to be done in Yugoslavia, Romania, Bulgaria, Greece and Turkey. These great personages of the Socialist International have stuck with the thinking of their great ancestors. They have not--unless they consciously want to dodge reality--taken cognizance of the fact that since Fourier, Louis Blanc, Proudhon, Marx, Engels, Jaures and Chernov , war could never be anymore what it still was in the 19th century and up to the middle of the 20th. These men of government should know that the space of these self-styled "denuclearized" zones can now be crossed in a few minutes by nuclear missiles whose precision is not altered by their long trajectory and that, in fact, technology being what it is, there can no longer exist on the surface of the globe geographic zones capable of being exempted from ballistic projectiles' landing on them, no matter what their point of departure.

It is true that these proposals are of great interest to the Soviet Union. From Iceland to Norway, the superiority of the Russian conventional forces could be manifested without impediments; and "denuclearization" of the Central Europe zone would bring about the collapse of NATO, while application of the same rules to Greece and Turkey would open the way to invasion by the conventional forces of the north. These sirens, seducing imperfectly informed citizens, have a powerful voice. The wind they breathe comes from the East.

#### FOOTNOTES

1. General Mery, "An Army, for Doing What, and How?," DEFENSE NATIONALE, June 1976, page 15.

For good measure, the programming law also added the northern approaches to the southern zones figuring in this text.

2. A sixth submarine, making a total of 96 missiles carried on board and 18 buried in the silos of the Albion Plateau.
3. Capable of attacking 500 objectives at most, not the thousand targets that the 350 SS-20's presently operational could attack.

11267

CSO: 3519/564

## BASES AGREEMENT VIEWED FROM VARIOUS POLITICAL ANGLES

## Economic Reasons Preponderant

Athens EXORMISI TIS KYRIAKIS in Greek 23 Jul 83 p 32

Editorial: "The Agreement and the Opposition"

Text The Right and its press are in deep mourning because, following the initialing of the agreement over the fate of the U.S. bases in our country, there was no case of anguish between PASOK and the KKE. For example, MESIMVRINI came out the day before yesterday with a whole-page headline, "Why Florakis Accepted the Agreement. The KKE avoided a Clash and Limited Itself to Verbal Polemics."

It then goes on to explain that the KKE was obedient to the "Ponomariov directive" that was expressed in the well-known TASS telegram, while the article that followed mentioned concessions by the United States thanks to the "vigorous stance taken by the Greek Government." Going on to prefabricated scenarios, MESIMVRINI talks about the "formation of a popular front when the time for elections comes" or about the "establishment of a post-election PASOK-KKE cooperation government according to the French model."

We are not among those who will say that the KKE was obedient to some kind of outside "directive." What we have to say is the following:

- The agreement on the time frame for the withdrawal of the bases, that is accompanied by the acceptance of all Greek conditions during the duration of their temporary maintenance (exactly as specified in PASOK's pre-electoral program), constitutes an amazing victory for the PASOK government that found the golden mean, recognizing national defense needs, the existing capabilities and the international correlation of forces, displacing the central weight of this correlation by one step so as not cause any upsetting with its inevitable consequences, which none of the superpowers would have wanted under present conditions. In this light, we would be able to see the Soviet approval of the agreement.

The KKE has the brains to judge, regardless of "directives" and, above all, just a glance at the rightist press should convince it about the hidden joy with which it is awaiting a frontal rupture and about its disappointment that this rupture did not come about.

- The KKE slogan for the withdrawal of the bases within the time frame of the present parliament is a sterile kind of slogan for its followers including those who did not read either the PASOK government program or the government's program statements.
- The KKE proposal for a referendum is also a sterile kind of sloganeering since even it knows that in such a case the voting against the agreement would have garnered only its own votes and perhaps none other.
- The bases agreement is a brave step forward on the path toward the acquisition and establishment of our national independence and the securing of peace generally speaking and in our region specifically. And that is not all. The parallel big step in the direction taken by the pacification role of the PASOK government is twofold: the withdrawal of --any kind-- of nuclear weapons from the soil of our country and the establishment of a denuclearized zone in the Balkans. Anyone who is following what is happening with regard to the acceptance and establishment of American nuclear weapons on European territory must appreciate even more deeply these initiatives by the Greek Government.

For all of these reasons and a series of others that relate mainly to the economic problems of the country, the agreement that the PASOK government succeeded in getting constitutes an achievement. An achievement that broadens its political role, guarantees the needed framework for the steps toward Change that are quickening and are bilaterally broadening its popular base.

#### Foreign, Domestic Policy Sides

Athens TA NEA in Greek 19 Jul 83 p 4

/Commentary by Khristos Rozakis: "The New U.S. Bases Agreement and the Exercise of National Policy"/

/Text/ There are many ways in which to judge --even though provisionally on the basis of the first government statements-- the new Greek-American defense and economic cooperation agreement that was initialed on 15 July 1983. Of course, a logical way to approximate the general principles that were enunciated would be to find out the extent of the conflict between the agreement and the more general aims of foreign and domestic policy that coincide with the status of the bases that is being renewed on the basis of the agreement. In other words, if we consider valid the case that the establishment or maintenance of foreign military bases in a given country constitutes a blow to unconstrained exercise of national policy, the question is what is the apparent extent of this blow with regard to the specific conditions of the new agreement and national policy expectations.

#### 1. Foreign Policy

Let us start out with foreign policy. About 2 years of exercise of foreign policy by the PASOK government reveals that its basic pursuits are designed, on the one hand, to upgrade the place and role of Greece in the western system and, on the other hand, to maximize the benefits from an opening towards countries that are outside the western system, such as the Balkans, the Arabs and the socialists of Eastern Europe. And all of this constantly under the vigilant priority for the

settlement of Greek-Turkish disputes that has taken on the form of a struggle for precedence in the international arena with the hope that a successful outcome would diminish the negotiating power of our neighbor and would force it to a rationalization and reduction of its excessive claims.

Is this policy contradictory to the specific 5-year renewal of the status of the bases? The answer cannot, of course, have only one significant aspect. With regard to the "western" policy of the government, tough negotiations and the subsequent achievements, through American acceptance of the primary Greek conditions (the bases do not serve mutual interests, a fixed date for the end of the agreement, control over activities) are consistent with the logic of an inter-western upgrading. Indeed, we could maintain that it constitutes the first tangible achievement in the course for improving the Greek image in the western world, without, however, wanting through this statement to diminish other "heretical" positions of the government that could, on a long-term basis, be imposed on the framework of the functioning of western institutions.

With regard to what is called the "exo-systemic" policy of the government (its policy vis-a-vis countries that do not belong to the western system), the 5-year agreement renewal can have some repercussions. If we exclude from the discussion the socialist countries of Eastern Europe, with whom conditions for the development of our relations have been laid down both by the centrist judgements of our domestic policy (social-economic status) as well as our stay in NATO, then the only "possible" affected part of our policy could be the Mediterranean-Arab dimension of our foreign relations.

At this point, there is one problem in principle. Given the American tendency to develop an active Mediterranean-Middle Eastern policy, the maintenance of American strategic initiative in the area of the long-term control over political and social developments in the region, the presence of the American bases in Greece --reinforced with the effectiveness of the Sixth Fleet-- is helping the daily, and beneficial for the Atlanticists, correlation of forces in the Mediterranean, and is connected with the permanent (and not temporary) interventionist feature of the American presence in warm seas.

A renewed agreement cannot, of course, thwart this feature because it has an almost symbolic role. What the agreement seems to succeed in is preventing the entanglement of our country in case of an escalation of a confrontation in the Mediterranean. Here, there are quite a few guarantees: first of all, the exclusion from the agreement of the provision for reciprocity in defense interests of the two countries provides greater effectiveness if the government's effort is to see to it that our Mediterranean and Middle East policy is protected instead of the "corresponding" eastern policy which at this point is irreparably suffering because of our participation in NATO. Secondly, the article of the agreement committing the Americans to develop only defense type actions, tied in with Greek control over the type of actions, constitutes a guarantee for limiting its arbitrary use, despite the fact that the confidence of all those who have been basically engaged in international affairs has been significantly shaken with regard to the meaning of defense. Thirdly, the possibility offered by a relevant article of the agreement for Greece to impose restrictions on or even to suspend the bases operations whenever it judges that an exceptional need for this exists.

Despite the fact that this provision relates rather to other kinds of possibilities dealing with national integrity and security, the probability of its being invoked in case of unusual developments in the Mediterranean --when the national territory would be threatened because of assaults on the bases-- must not be ruled out. With the condition, of course, that the formulation of the relevant article is rather flexible.

The existence of these conditions in the new agreement has a dual meaning for Greek policy: on the one hand, the meaning of activation of the provisions in case of a crisis in the Mediterranean in which Americans, Arabs and (perhaps) Soviets are all involved. On the other hand, the meaning of their being invoked, during a period of peaceful conditions, against those interested parties (Arabs, even Soviets), as a means for calming down their concerns over the prolongation of the American military stay in Greece. These provisions also have their political meaning to the extent they are being used as a means for neutralizing the negative aspects of the military's stay in Greece.

## 2. National Security

The relationship of the renewal of the status of the bases with the country's national security has two aspects: the Greek-Turkish aspect and the broader international policy aspect.

The Greek-Turkish aspect appears to bear the main weight for the responsibility for the renewing of the agreement. For that reason, the return offerings, both direct and indirect, are significant: (a) assurance of the 7 to 10 ratio, through the exchange of letters, and consequently contractually binding on the American administration; (b) existence of a contractual stipulation that permits the revocation of the agreement in case where Greece deems "that there is an effort being made to upset the balance in favor of Turkey." At this point it would be of interest for us to learn the exact formulation of both the letters and the contractual stipulations of the revocation, although it follows from the prime minister's statement that the Americans have essentially agreed to claim understanding of the threat that Greece feels as coming from her neighbor --since it even agreed to the revocation in case of an upset in the balance, something that, in any case, it had refused agreeing to in the past; (c) a logical consequence of the renewal of the agreement, namely the smoothing out of Greek-American relations, with, of course, an obvious dispersion of American interest between the two neighboring countries that could be translated into active interjection to maintain peace and security in the region.

Greek success in this aspect of the agreement's renewal does, of course, have its price: we refer to both military and political mortgaging that the contractually secured U.S. interest is leading to in our relations with Turkey, as well as what we described above as "a broader international policy aspect." More specifically with regard to the latter, we should point out that the agreement renewal coincides with the U.S. hardening of its relations with the outside world and a discernment of outspokenness that distinguishes its foreign policy. This discernment led the Americans to back off in the face of Greek demands (since they were not disposed to endanger any of their advance positions in the Mediterranean) but this same directness and irreconciliability could in the future cause us problems with countries that are targets of the United States. The escape

clauses that the new agreement provides for --and which we mentioned above-- theoretically disengage us from American policy, but they do not disengage us, at a time of a real international crisis, from the difficult political dilemma if we were to invoke these provisions and who we would prefer sacrificing by invoking or not invoking them.

### 3. Domestic Policy

The effect of the presence of the American bases on issues of domestic policy, especially on the jurisdiction and legal rights of internal organs to engage in matters that occur on national territory, is significantly lessened with the new status. The abolition of extraterritoriality and the decisive role of the Greek executive in determining acts that interest the Greek state constitutes the end, and formally so, of "stipulations" that were a burden to us in the past. Nonetheless, there remains the re-negotiation of a large number of agreements, many of which appear to contain provisions that diminish Greek independence, so as to definitively put an end to this post-war affliction.

While awaiting the final text that will shed light on certain important details of the new status, we combine our conviction with the understanding that the new agreement constitutes a courageous modernization of the bases status that, nevertheless, requires both constant vigilance during the duration of its being in force, as well as a struggle for its final revocation. The open question that remains is whether, during the period before its termination, the sought after conditions succeed in promoting peace, detente and in lessening the military role in international affairs.

#### Rozakis' View Contested

Athens ELEVTHEROTYPIA in Greek 23 Jul 83 p 4

Commentary by V. Filias: "The Bases: The Agreement and Semantics"

Excerpts In connection with the controversial bases issue, there were those who obviously contended that the bases must be withdrawn, whereas others maintained just the opposite, namely that they should remain. There was also a third group that was of the opinion that the bases would remain because the Americans were in a position to force their remaining, regardless of what our own intention was. These positions were supported with arguments --whether correctly or erroneously, no matter-- and, at any rate, they had the political price that any concrete political position entails, especially, indeed, on such a critical and important issue.

The government preferred the path of the expedient confusion of the three positions so as to avoid the political price of its decisions that in each instance comes into clear opposition with its pre-electoral pronouncements.

A typical example of the relevant semantics that, indeed, appears with the mantle of analytical objectivity, is the article by the Pandeion professor, Khristos Rozakis, that appeared in TA NEA last Tuesday (19 July 1983), titled "The New U.S. Bases Agreement and the Exercise of National Policy" and subtitled "the third dimension."

As an associate he is a friend, the truth, however, is dearest....

So, after many varied generalities and introductory comments, Mr Rozakis tells us the following:

First of all, PASOK's proclaimed foreign policy is not inconsistent with the signing of the bases agreement. He specifically mentions:

"Let us start out with foreign policy. About 2 years of its exercise by the PASOK government reveals that the basic pursuits are designed, on the one hand, to upgrade the place and role of Greece in the western system, and, on the other hand, to maximize the benefits from an opening towards countries outside the system, such as the Balkans, the Arabs and the socialists of Eastern Europe. And all of this constantly under the vigilant priority for the settlement of Greek-Turkish disputes that has taken on the form of a struggle for precedence in the international arena, with the hope that a successful outcome would diminish the negotiating power of our neighbor and would force it to a rationalization and reduction of its excessive claims.

"Is this policy contradictory to the specific 5-year renewal of the status of the bases. The answer cannot, of course, have only one significant aspect."

First of all, it is not a question of a 5-year renewal but, in fact, an 8-year one, something our colleague should have known.

Mr Rozakis tells us, "vigilant priority" is being given for the settlement of Greek-Turkish issues that has taken on the form of a struggle "for precedence in the international arena."

So, we are renewing the agreements in order to ensure this precedence, with the hope that the negotiating ability of the Turks would diminish, with the possible result being that their excessive claims might be reduced.

Secondly, Mr Rozakis maintains that the signing of the bases agreement does not prejudice the "opening" to the Arabs by our country.

Consequently, Mr Rozakis assures us, despite the active development of a Mediterranean-Middle Eastern policy by the United States, the role of the American bases in Greece is "almost symbolic in nature." In other words, a question of prestige presence --what else can "symbolic" mean-- a kind of political gesture. For that reason we have aircraft launching bases, supply of surface war vessels and submarines; for that reason we have nuclear warheads and missiles; for that reason we have ultramodern espionage and intelligence systems. All of that just for the show!!! Besides, our colleague writes, we have the exclusion clause for reciprocity that protects us from an "entanglement" if our national interests do not require it, that, in essence, means that we can pharisaically wash our hands when blows "of active" U.S. intervention are struck, blows, that originate from Greek territory, against peoples with whom, it is presumed, we want to have friendly relations. If, however, they should

overdo it, the writer argues in a third case, we could suspend the operation of the bases in accordance with the terms of the agreement, terms that, at any rate, related to an instance of a danger to our national integrity --as the writer himself admits.

Thirdly, Mr Rozakis writes that the renewal agreement strengthens our national security vis-a-vis Turkey.

Consequently, the problem is confined, from the viewpoint of national security, to the maintenance of the 7:10 ratio. And what is to be done with the invisible resources that ensure a gold mine influx of American and German war materiel to Turkey? How do you explain the fact that Turkey that "is on the verge of bankruptcy" is establishing one war industry after another; with what secret capital, with what resources? But let us overlook that and let us move on to the price of our success, that the writer mentions.

What does the "hardening" and the "outspokenness" of American policy mean for us? How will we confront, with our national interest as a criterion, this outspokenness when its essential consequence will be a greater --if not altogether-- dependence on the United States as far as war materiel is concerned? With what basis will we, in the future, fight against a more intense American policy of "preference" for our neighboring deadly friend.

The Americans have never hesitated to entrap and to betray, even their own subservient April /1967/ junta, their own fabrication. How can we forget that, and, indeed, on these days celebrating the ninth black anniversary /since the overthrow of the junta in 1974/?

It is not only unpleasant but something more than dangerous for our colleague, Mr Rozakis, not to seem to have realized the fact that in international relations --that are, in fact, his area of specialization-- under the surface crust of a diplomatic "third dimesion" lie the harsh and cruel magnitudes of politics. Perhaps for that reason he acts with such dexterity on the level of an intellectual game of imaginary balances that, any rate, has the advantage of avoiding pitfalls.

There are still, our colleague concludes at some point, many provisions in the agreements that diminish Greek "independence" that we must get at through negotiations so as to "definitively put an end to this post-war affliction." A curious choice for this sentimental and distressed word "affliction" to describe the big stick of the foreign controller and the web of instruments of dependence.

Mr Rozakis, who is usually careful, guarded and balanced, has surprised us with his precipitate taking a stance in favor of the agreements even prior to their text being published --and we wonder.

## KKE-PASOK Relations

Athens RIZOSPASTIS in Greek 20 Jul 83 p 1

Editorial: "A Well-Known Method"

Text One segment of the press, primarily the rightist press, is given to speculation. It contends that the KKE allegedly "for both external and internal reasons" has "lowered" the tone of its criticism over the bases agreement. This method is well known, and even more well known is the position of these circles who cannot think any differently except through the logic of foreign suggestions. The KKE, of course, neither "upgrades" nor "downgrades" the agreements issue.

The positioning of the party from the very outset, together with the statement by its central committee secretary general, Comrade Kh. Florakis, as well as with the announcement of the central committee politbureau, was crystal clear. We have to do with an agreement for maintaining the bases, an agreement that is in clear opposition to the manifest popular mandate of 18 October 1981 for their withdrawal. So long as the government insists on signing it, it is obliged to bring it before the people so they may make a judgement through a referendum. Therefore, the recourse to staged published articles and imaginary scenarios that accompany them is obvious: deception. They want to create confusion in and a reorientation of public opinion.

And, first of all, they are trying to weaken the popular front for the withdrawal of the bases by erecting barriers primarily among KKE and PASOK adherents. Vainly, of course. The popular demonstrations against the agreement is what is setting the tone for the entire country regardless of how much the bourgeois press tries to silence them and to downgrade them. Popular unity and the struggle for the withdrawal of the bases will ceaselessly be extended and strengthened.

### 1983 Agreement No Different

Athens POLITIKA THEMATA in Greek No 463, 22-28 Jul 83 pp 13-14

Editorial: "The U.S. Bases: Profits and Losses. A First Review"

Text The fact that neither the prime minister nor the government wanted to provide certain explanations to the doubts of public opinion that were brought about through its own actions has provoked a sensation, many questions and suspicions.

Specifically, Mr Papandreou did not consider it a political duty to explain to the Greek people why it took him 21 months in office to settle such a serious and critical problem. Why he did not at once move forward toward settling it since the way he finally decided on settling it was about the same as the one that New Democracy government had followed.

However, Mr Papandreou deemed it unnecessary to explain why he did not dare announce the agreement a month ago. What, in essence, was "the serious difference on basic issues" that called for a 1-month postponement of the initialing?

It appears that Mr Papandreou needed 4 more weeks to convince his extremist cadres to accept the agreement and he himself to find the courage to assume the political responsibility for the agreement.

No other justification can be accepted, when western diplomats, the very next day after the departure of the American negotiator, Mr Reginald Bartholomew, for Washington, talked not only about an agreement that had been attained but also revealed its terms in their discussions.

A general review of what the Papandreou government succeeded in "getting" from the Americans, in comparison with what the K. Karamanlis government had secured (April 1976), is not favorable for our present leaders.

PASOK has not succeeded in holding on to any, or almost any, of the national benefits obtained by the then Minister of Foreign Affairs Dimitrios Bitsios (that resulted from the agreement of principles that he signed together with the then head of the State Department Henry Kissinger). Specifically:

1. He failed in ensuring an American guarantee of our eastern frontiers and peace in the Aegean that was provided for in the well-known Kissinger letter to Mr Bitsios. The contents of this letter had also been secured by the G. Rallis government following the meeting between Kon. Mitsotakis and Alex. Haig in Rome (May 1981).
2. The agreement then had been set for 4 years (not 5 years) with the possibility of its being terminated prior to its expiration, as well as its being renewed on an annual basis.
3. Each base was considered Greek, with a Greek commander. The participation of Greek personnel would come up to 50 percent of the overall personnel.
4. Joint and complete acquisition of all intelligence information that would be collected by the bases.
5. A new legal status for the American forces that would be stationed in our country.
6. Contractual obligation by the United States to grant Greece American military assistance in the amount of 700 million dollars over a period of 4 years (in comparison with an amount of 1.1 billion dollars to Turkey for the same period).

However, many of the loudmouthed government "claims" were finally forgotten, as shown in the final text of the agreement.

Thus, the repayment or the famous "rent" for the bases that had been set at a level of 1 billion dollars was quickly forgotten by the government.

Just as the prime minister's famous warning was forgotten namely that his government would firmly insist on the 7:10 ratio, in the calculation of which, however, both defense and economic aid to Turkey would be computed. Turkey, however, will get military assistance amounting to 715 billion dollars and economic assistance amounting to 175 billion dollars this year. The overall sum is therefore 890 billion dollars, whereas we will get 500 million dollars.

Of course, the Hellenization of the bases has been definitely abandoned, together with the complete reversal of the original government assurance that they do not serve Greek interests.

Because it is at least an affront to public opinion for us to maintain that the bases serve only American interests, while at the same time, however, to maintain that we have secured 500 million dollars for our defense purposes.

#### Agreement Within Aegean Context

Athens KYRIAKATI KI ELEVTHEROTYPIA in Greek 24 Jul 83 p 4

Analysis by Kostas Angelopoulos: "How Does Washington Associate the Bases, NATO, the Aegean and the Cypriot Question?"

Text The day is soon approaching when Minister of Foreign Affairs Giannis Kharalambopoulos and U.S. Ambassador to Athens Sterns will sign the political agreement on the bases that was initialed on 15 July following many long months of "marathon" talks between Kapsis and Bartholomew. There will then remain the ratification of the agreement by parliament in October and a small "second round" at which Greece and the United States will discuss various technical and legal "adjustments" that, according to the agreement, will have to be completed within a year so that we might be then able to talk, in fact, about a "new operating status for the U.S. bases" in our country.

Many commentaries and analyses have already been written on the political agreement between Greece and the United States, with the government spokesman, indeed, recommending to analysts that they remain "patient" until the publication of the official texts of the agreement --they will have been made public in about 10 days. Nevertheless, from the very first public or unofficial reaction in Athens and Washington, we have a first taste of the agreement: both sides talk about success, something that means that there are profits and losses for both sides --and it could not be otherwise.

We will not deal at this point on whether or not the 5-year agreement has a "time frame for withdrawal" feature, something that will shortly be cleared up with the publication of the text of the agreement. We will also be waiting for this publication to see in what way and to what extent the possibility is given to the two parties to move forward toward the abrogation of or change in the great majority of the 108 old agreements that constitute the network of operating regulations for the U.S. bases in Greece (it was announced that this change is being contractually determined and that it must take place within a year following the agreement's going into effect, but there is also information to the effect that a prolongation is provided for if the two parties deem it "necessary").

In this article, we will try, in summary fashion, to place the development of the initialing of the Greek-U.S. agreement into the "square" of national issues: bases, Aegean, NATO and Cypriot question.

Is Ankara Being "Pressured?"

If one were to ask the behind-the-scenes diplomatic arena what is being done with the issue of Greek-NATO relations, he would hear the answer "the issue seems to have a satisfactory development." This is translated to mean that NATO appears ready to discuss now the firm Greek position that wants the establishment of a NATO headquarters in Larisa exclusively linked to the recognition of the status of military control over the Aegean as it existed up to 1974.

According to our sources, the Americans, who feel that with all the restrictions contained in the agreement with Greece, the development of the initialing has important positive points for them too, are showing that they are now disposed toward "pressuring" Ankara to accept, within NATO's framework, the Greek position on the issue of the Larisa headquarters. It is easily obvious that if such "pressure" succeeds, the overall issue would result in a more general detente in the Aegean, since in this way Ankara would have essentially given up the demand that primarily brought about the Greek-Turkish "dispute."

So, could one suppose that the Greek-U.S. agreement is close to automatically leading to a "settlement" of our country's problems with NATO and Ankara, as well as to detente in the Aegean?

Perhaps to admit that it is close to that. The question is, however, would such a development in our country's policy on national issues be "a gratis one." This is so because there is the Cypriot issue. The major national issue, the one so closely tied in with Greece's national security. And as revealed by recent events, the Cypriot problem is in the center of "curious" developments --or, better still, non-developments. Something that does not portend anything good.

This is so because for some time now the famous "initiatives" taken by UN Secretary General de Cuellar have ceased (to tell the truth, this is a State Department "success").

Because the unusual thing recently is the fact while Mr de Cuellar supports one thing behind-the-scenes, his representative for Cypriot affairs, Mr Gobbi, supports something else, and both criticize each other for...inconsistency. In the meantime, the Greek diplomats at the United Nations stunned at this development hear that "it is difficult to confront the tough Turkish Cypriot stance" and "things are very difficult with the Cypriot situation generally-speaking."

For experienced diplomats, it is somewhat clear that "something is happening." Or, better still, that "it is possible that something will happen." It is a common secret for westerners that the United States and NATO are finally in a hurry to strategically "improve" the situation that had developed on the island following the Turkish invasion of 1974. Their needs in the Middle East and in regions further eastward are known.

Dazed by this unnatural diplomatic confusion, Nicosia does not seem --as it is being said-- to make the proper moves. Also contributing to this is the fact that "strong parties" in the EEC are raising their hands but also none appear willing to wager that Moscow would decisively oppose a "settlement" that would shirk the demand for a united, independent Cyprus, without foreign troops on its soil.

So, will the United States and NATO try to have the situation in the Aegean "abate" (because let no one believe for one moment the myth that Washington "does not completely control" Ankara) so that in the future they may more easily, through staged international diplomatic confusion, obtain military benefits from the Cypriot issue? The question is not illogical. Greece's experience from American "reasoning" in the region is bitter.

Athens well knows what is happening with the Cypriot issue. The government is being completely informed by its services on developments. And, of course, it does not intend to follow events in a disinterested fashion. Because, just as it had been often stressed in the past, Prime Minister Papandreou has confronted the Cypriot issue from the very outset, not primarily from a "sentimental" standpoint, as his predecessors had conceived it, but by placing it in the context of the country's national security.

PASOK'S VICTORY CLAIM

Athens ANDI in Greek No 237, 22 Jul 83 cover page

[Cartoon]

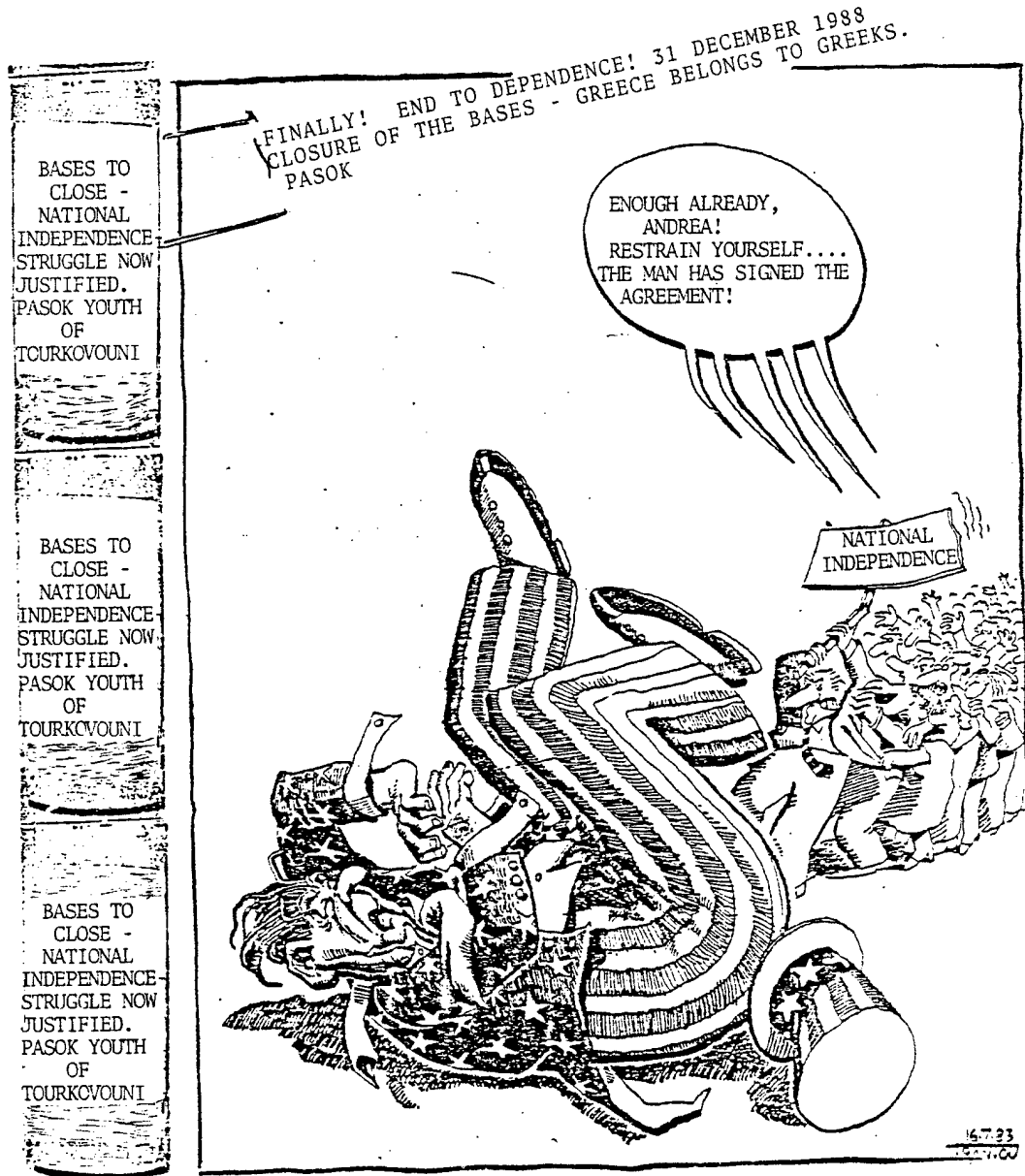

5671  
CSO: 3521/395

## PROBLEMS RAISED BY SPREADING OF CHADIAN CONFLICT

Athens I KATHIMERINI in Greek 15 Aug 83 p 1

[Article by Rikhardos Someritis: "Chad...Hides Some Problems for Athens Too"]

[Text] Paris--Unless a quick and peaceful solution is found for Chad, the Greed Government risks finding itself in a difficult situation--both automatically and as president of the EEC: it will be compelled to choose between "friends" and "enemies" if, as many fear, the war assumes wider proportions and becomes "internationalized."

According to indications and simultnaeously with the escalation of the fighting, diplomatic efforts for "national reconciliation" in Chad itself are increasing, which would prevent the spreading of military operations and an immediate confrontation between France and Libya.

Despite pressure exercised by the United States (which has awakened the violent reaction of French Government officials) and continuous demarches by the government of Chad, for the time being, the French have avoided a direct intervention in the fighting. The special forces they have sent to Chad (and which are increasing daily both in quantity and quality) have so far restricted themselves officially to the role of "advisors," while the French Air Force has not attempted to engage the Libyan Migs.

This negative and also dangerous development creates problems for Greece as well (and not only indirect). Should the war in Chad assume wider proportions, and should the West (France directly and the United States through war materiel) intervene in favor of Habre, just as Libya for weeks now (with the Soviet Union behind it) has intervened directly in favor of Goukkouni Weddeye, the consequences for the Greek Government could be the following:

--A problem in regard to the eventual use of the U.S. bases in Greece--mainly in Crete--for the shipment of materiel to Chad, for reconnaissance flights and for the control of naval and air communications between Libya and the Soviet Union. Already, the permits recently granted to Soviet aircraft loaded with military equipment for Libya to refuel in Greece have raised a controversy.

--A problem of "choosing friends and allies," which could prove decisive for the country's international relations and for domestic developments, more so, at any rate, than the issue of the "nuclear-free Balkans."

--A problem regarding the exercise of duties in the EEC presidency in the field of political cooperation.

--A possible problem regarding Greek-French relations, that would be multifaceted and whose seriousness should not be underrated. However, it is (relatively) strange that the Papandreou diplomacy, which theoretically should have ensured a multitude of "channels" for contacts and a variety of negotiation possibilities, does not seem able (or eager?) to embody the old dream of playing the part of a bridge between the West and the Middle East and Africa. This had become abundantly clear as late as a year ago, during the time of the battle for Beirut.

CSO: 3521/417

## PRESIDENTIAL SECRETARY HALLDOR REYNISSON ON PEACE MOVEMENT

Reykjavik MORGUNBLADID in Icelandic 16 Jul 83 p 7

[Commentary by Staksteinar: "The Peace Movement in KIRKJURIT"]

[Text] Staksteinar today is concerned with an article on the peace movement published by Presidential Secretary Halldor Reynisson in the most recent issue of KIRKJURIT. It is generally felt that the so-called peace movement has reached its high water mark in Europe and the United States in terms of mass meetings and other similar events associated with the peace movement. Moreover, there will henceforth be another kind of opposition to the efforts of the Western countries to answer the Soviet missile threat, that is to say, opposition based upon exertion of pressure on both the Western nations and the Soviet Union. Thereby we would come to have policemen and trained groups of opponents.

The Presidential Secretary on Peace

Presidential Secretary Halldor Reynisson has published an article in the latest issue of KIRKJURIT entitled "Are They Going to Salt the SALT Talks." At the beginning of the article the presidential secretary makes clear his disappointment that "the lively discussions that have developed about the danger of nuclear weapons have died away and vanished, at least in Iceland." Halldor Reynisson thinks that there is nothing amazing about the fact that "anything discussed in the high-speed mass media societies of the Western countries" goes past quickly. He goes on: "The peace issue overtook us Icelanders two years ago, to the joy of some and displeasure of others. But the nuclear weapons issue has never become such a general concern in Iceland to the same degree that both sides of the aluminum issue have been. In Iceland it has mostly been professional rabble rousers that have discussed the matter. Nonetheless, it has been the case that certain groups outside the customary channels of national debate have gotten themselves involved in the peace movement."

Only Very Few Megatons Are Lacking

One section of Halldor Reynisson's article in KIRKJURIT bears the title given above as a heading. It is stated there:

"Most likely the success of the Icelandic church in the peace debate will be thought good, at least by Icelandic standards. Nonetheless, the thought cannot be avoided that the power of the movement had to be a few megatons more to gain general acceptance. The discussion of the peace issue has, I dare say, been insipid of late and little more than a pleasant discussion between theologians. Some have said that the reasons for the general indifference in Iceland is that the issue is not so burning for us as for some peoples in Europe and America. Those individuals who see their vegetable gardens and flower beds dug up to erect hell's bombs are more likely to take offense than we in the North Atlantic, who have never, at any time, come near the tools of war.

"Perhaps there is nothing in this explanation for the apathy since the bombs are around, if out of sight. That is not to excuse the theologians and others that think they have something to do with the matter even though the public in Iceland is little concerned. In the face of the legions of bombs we are all in the same boat, the fishermen of Grimsey and the factory workers of the Ruhr. If one bomb goes off everything goes up in smoke. The bomb has united all men in its perverse way."

More "Gentle Talk" is Needed

Presidential Secretary Halldor Reynisson continued: "How is the church to address the peace issue? It should be in the light of the Gospel that Christians discuss peace. However, the theologians should push nuclear weapons beyond the concern of their discipline. The business of the priest should be other than the business of the military specialist, but both should know enough about the domain of the other to be able to talk together.

"But probably not all theologians would be in agreement about this and some no doubt think that there should be an effort toward friendly discussions on the weapons and on the arms balance of the great powers.

"Although people can have varying points of view as to where the discussions should begin, a considerable number will be nonetheless in agreement that pleasant discussion of the peace issue has not gone very far in Iceland. Likewise, there will be few opposed to the idea that the education of the public in this area has been limited. The exception is the efforts made in connection with the youth work of the Icelandic State Church with regard to the last Church Youth Day. There is thus a great need for more attention to what may be called the 'theology of the bombs.'"

Effort to No Good Purpose

Halldor Reynisson concludes his article in KIRKJURIT by saying that he had said little about the "substantive issues," but rather discussed the question as to whether or not church men ought to devote more attention to the peace issue. Certainly it would have been interesting for the readers of KIRKJURIT

to find out the views of Reynisson on the "substantive issues" which have been much in the news here and abroad. This is the most important thing about the matter, namely that people come to common conclusions about it. It was possible to come to such conclusions for example in the European Missile Discussions in Geneva, conclusions in agreement with the policy of the Atlantic Alliance Nations. Thereby all medium range missiles would be removed, not only from Europe, but entirely from the face of the earth. "Peace discussions" without an objective position being taken is certainly, like some other things, mass media mischief and Halldor Reynisson is right in saying that it would be better if this stage passed quickly.

9857

CSO: 3626/48

## POLL MEASURES VOTER LOYALTY TO PARTIES AS ELECTIONS NEAR

Oslo AFTENPOSTEN in Norwegian 26 Jul 83 p 3

[Article by Bibi Vance: "New NOI [Norwegian Opinion Institute] Poll: Little Change in Voter Stability"]

[Text] If there were a Storting election tomorrow, 82 percent of the Labor Party's voters in the 1981 election would certainly vote for the same party, the June figures for the Norwegian Opinion Institute's political stability survey show. Then come the Christian People's Party with 80 percent and the Conservative Party and Center Party with 79 percent. The Liberal Party has the lowest voter stability, with 54 percent of 1981 voters who would stick by the party. All those questioned voted in the 1981 Storting election.

The figure is 75 percent for the Socialist Left Party and 56 percent for the Progressive Party.

The Norwegian Opinion Institute's poll from April to June regarding revoting for the same party in the Storting election shows that the Liberal Party has made the greatest gain, of 3 percent, while the Progressive Party has lost the most, 14 percent. During the same period the Labor Party's supporters have increased 1 percent. While the Conservative Party and Center Party show the same figures as in April, the Christian People's Party shows a decline of 6 percent.

The poll for May regarding political stability shows that the Liberal Party increased its percentage by 8 percent while the Center Party increased by 2 percent, the Labor Party had the same percentage as the month before, while the percentage of all other parties was reduced from April to May.

The Christian People's Party suffered the greatest decline in this period, by 17 percent, the Center Party and Liberal Party by 8 percent, the Progressive Party by 7 percent, the Conservative Party by 5 percent, and the Socialist Left Party suffered a decline of 1 percent from April to May.

The number questioned in the separate monthly study is between 30 and 80 for all other parties than the Labor Party and the Conservative Party. Significant margins of error must therefore be taken into account, the Norwegian Opinion Institute states, which asked the 1003 persons questioned the following question:

"Did you vote in the 1981 Storting election? If yes, if there were a Storting election tomorrow is it absolutely certain that you would vote for the same party as last time, or would you consider whether you should perhaps vote for another party, or would you quite definitely vote for another party, or would you perhaps not vote, or are you uncertain about what you would do?"

In June a total of 63 percent answered that they would vote for the same party, 10 percent answered that they perhaps would vote for another party, 3 percent would quite definitely vote for another party, and the same percentage would perhaps not vote, while 21 percent were unsure about what they would do.

Sixty-five percent of the men questioned and 60 percent of the women answered that they would vote for the same party. Eighty percent of the group questioned over 60 years old answered the same, while 32 percent of the group questioned under 30 years old answered that they would vote for the same party. Within the age group of 30 to 59 years old, 74 percent said they would vote for the same party. Most uncertain was the group under 30 years old, with 44 percent who are unsure about what they would do in a Storting election tomorrow, while 10 percent of the group between 30 and 59 years old and 13 percent of the group over 60 years old also did not know what they would do.

The most faithful voters were among those who have a family income of under 100,000 kroner, with 68 percent; in the group with a family income of up to 160,000 kroner 61 percent would vote for the same party, and for those with an income over this, 59 percent would vote for the same party as in the last Storting election.

The political stability survey shows also that 69 percent of those who are members of the LO [Federation of Trade Unions] would vote for the same party as in the last Storting election, and that 75 percent of those who are members of other labor organizations would vote for the same party as last time. Of those questioned who are not part of organized labor, 58 percent answered that they would vote for the same party as they did in the 1981 Storting election.

8985

CSO: 3639/153

PAPER: GOOD POLL RESULT FOR CONSERVATIVES

Oslo AFTENPOSTEN in Norwegian 26 Jul 83 p 2

[Editorial: "Satisfaction with Willoch"]

[Text] In the middle of a time of economic difficulties for the country, reduced competitiveness in Norwegian industry and increased unemployment, the majority of the people come out and declare satisfaction with the policy which has been carried out under the purely Conservative government. The growth in approval is greatest among people with the lowest family income. At the same time the Labor Party's vice-chairman, Einar Førde, is inciting the AUF-ers [Labor Party Youth Organization members] on Utøya with the "Conservative fiasco." One is tempted to use Bertolt Brecht's well-known words regarding disagreement between the party and people-- the party needs a new people.

For Prime Minister Kåre Willoch and the Conservative Party this poll must be an incentive for the further job of getting the country on its feet economically, and Undersecretary Erling Norvik indeed hits upon the truth when he believes in increased respect and understanding among the people of the stringent policy the government has had to carry out and must continue to carry out for some time to come.

The poll for June can be regarded as a final evaluation of the Conservative administration's job before it was expanded with participation of the Christian People's Party and Center Party. At the same time it gives a general view of the attitude of voters midway in the Storting session. The conclusion is that the former Conservative administration has not experienced any of the wear and tear which has been well known in all of Western Europe when times are difficult. On the contrary, it is the object of record-high satisfaction, first and foremost from the voter groups which are not included by the socialist opposition among the Conservative Party's most ardent admirers. The people approve of responsibility instead of falling for cheap outbidding politics.

Former Prime Minister, and the Center Party's old leader, Per Borten yesterday obliged with his fundamental distrust of a strong Conservative Party and of what it, according to his opinion, stands for. Here Mr. Borten's legendary political nose has failed him. Seventy percent of the Center Party's voters like the policy Willoch's Conservative administration has stood for. Respect has been growing in rural communities. This confirms what many have suspected: The expansion of the

government did not take place first and foremost as the result of a "worn-out cooperation model." The in-between parties' leaders simply followed the current which was and is totally dominant among their own voters. These voters do not appear to be afraid of being "run over" by the Conservative Party. They are not even alien to the policy the Conservative Party has carried out.

The strong vote of confidence should also urge the Labor Party to reflections when we are now entering the election campaign in seriousness. Einar Førde's broadside against the "Conservative fiasco" is certainly not too encouraging in this respect, but it is still not too late for the opposition to tune into what are the country's real problems and to slogans which are understood and accepted.

8985

CSO: 3639/153

## OPPOSITION, CONSERVATIVE NEWSPAPER COMMENT ON MADRID MEETING

## Labor Party Paper Satisfied

Oslo ARBEIDERBLADET in Norwegian 16 Jul 83 p 2

Editorial

Text After nearly three years of long and difficult negotiations, it appears as if the Madrid Conference on security and cooperation in Europe (CSCE) is now approaching a conclusion. On Thursday of this week the chief American delegate Max Kampelman made it clear that the United States does not have any significant objections to the compromise reached by the parties. Thus there remains only some minor revisions before the final document is ready for signatures. That is both surprising and fortunate. It is surprising because until recently the obstacles to agreement seemed insurmountable; it is fortunate because the agreement comes at a time when both Europe and the world need a political boost.

When the Madrid conference commenced in November 1980, the 35 participating countries knew that the international diplomatic climate was not the best. Nevertheless there were probably few who expected that the conference would drag on for so long. It may be of some compensation to the CSCE negotiators that several other international conferences besides CSCE have had similar rough going. Yes, indeed, we are now seeing the first significant agreement between East and West since the Soviet invasion of Afghanistan in December 1979.

The purpose of the conference in Madrid has been to evaluate to what extent the participating countries have followed the Helsinki declaration of 1975. In addition the delegates have worked on several new proposals for the purpose of promoting security and cooperation in Europe.

What then have been the results at the end?

Like the Helsinki declaration the document that has now been worked out is a lengthy mixture of relatively concrete decisions and good intentions. In several areas the participating countries will without doubt exert themselves to achieve the document's formal provisions. In other areas, however, we must expect that the parties will continue to interpret the provisions differently.

This is especially the case with the document's section on human rights. In this section the participating countries will again state that they agree "to promote and encourage the effective exercise of human rights and basic freedoms." But from past experience the western countries know that the Soviet Union and its eastern European allies will not live up to that promise. And now as before the eastern European countries will reject all western criticism on this point as "interference in domestic affairs."

The western countries are nonetheless willing to accept the agreement because the sum of the negotiations is acceptable. In several areas the eastern European countries have made concession which the western countries believe are significant.

In addition the signatory states have agreed upon the mandate for a European disarmament conference, which is to begin already next January. Two other meetings in the CSCE system will commence in 1985 and 1986. The first meeting will focus upon human rights problems. The second will seek to establish more effective procedures for so-called "human contacts" including the reunification of divided families.

Finally mentioned should be made of a new CSCE conference which the Madrid document schedules for Vienna in 1986. All this means that the patient negotiators in Madrid have succeeded in keeping alive the CSCE cooperation. At the same time they have sparked new hope that the two power blocs, in spite of all their differences, have maintained the ability to talk together.

There is no reason to be overly optimistic in one's expectations. The international political climate in the near future will be more dependent upon the missile negotiations in Geneva than the CSCE process. And progress there is very difficult. Two days ago the chief negotiators on the controversial intermediate range missiles began a two month recess. Reports from Geneva note that even at the final meeting before the negotiating recess there was no sign of movement in the different positions.

So the path forward remains long.

#### Conservation Paper Less Optimistic

Oslo AFTENPOSTEN in Norwegian 18 Jul 83 p 2

#### [Editorial]

[Text] The agreement upon a final document from Madrid comes at a time when there are several other signs of slightly eased relations between the U.S.A. and the Soviet Union. The Soviet side has put forward a proposal at the strategic arms talks in Geneva for reductions, and the Americans have characterized the proposal as interesting, even if it is not completely satisfactory. Spokesmen in Washington say that they have received Soviet hints of amnesty for individual political prisoners, and in the course of this week martial law will probably be lifted in Poland.

Given the freeze in great power politics since the Soviet invasion of Afghanistan at new year's 1979-1980, this is encouraging. No one is becoming delirious with joy because during the peak period of detente in 1972-1975, expectations in the west were too great. The disappointment was correspondingly great. This time people in the west should be able to see the limitations which the Soviet system itself places on all efforts for relaxation of tensions.

These limitations are most clearly visible in Soviet human rights policies. People who on their own initiative stated that they would work for the achievement of the principles to which the Soviet government had adhered were imprisoned for anti-Soviet activities. Such a practice is worthy of several exclamation marks, but basically it is natural for a regime that insists upon a monopoly of power, including full control of all public expression and organizations. For this reason one should not expect too much of the conference of experts on human rights which will be held in Switzerland in 1986 and which is another continuation of the Helsinki document and the declaration upon which agreement was reached in Madrid.

In regard to Poland, it is possible that western sanctions can be removed when martial law is lifted on Friday. The Americans have been impatient for this, even though it is clear that the conditions that were made for removal can hardly be met. One of them was for a dialogue between the authorities and the Polish people. This would be in the best of circumstances a muted dialogue. Nor is there any reason to expect trade unions with the freedoms promised by the 31 August 1980 agreement.

But the Poles have achieved something with their tenacity under martial law. Above everything it has shown Moscow that stability in Poland cannot perhaps be secured with the same methods which were used in Czechoslovakia. Once again it is a question of achieving political security control without total social control. This has not been the Kremlin's strong point over the years. But the control has created both dissatisfaction and crises in the Soviet sphere for years. That is why it is in conflict with the purpose of the Helsinki process, to promote security and cooperation in our part of the world. The small amount of optimism which has leaked to the surface after nearly three years of deadlock in Madrid stems from the hope that Moscow perhaps can understand this relationship.

9906  
CSO: 3639/151

## GALLUP ORGANIZATION REORGANIZED; NEW POLL SCHEDULE

Oslo AFTENPOSTEN in Norwegian 14 Jul 83 p 3

[Article: "Gallup/NOI/AFTENPOSTEN: New Gallup Institute"]

[Text] A new opinion poll institute has been established in Norway, the Gallup International Norge A/S. It is the Gallup International Association that is registered in Switzerland and with its general secretariat in London that has taken the initiative in this reorganization.

Chairman of the Board of Gallup International Associations is George H. Gallup, the pioneer of polls and opinion surveys who after having passed the age of 80 continues to be active. The company has members in approximately 50 countries which all are authorized representatives in their respective countries. An extensive exchange of experience and professional expertise takes place between these institutes, so that at all times all are kept oriented about new professional developments all around the world.

The motive for the reorganization of Gallup International Norge A/S was to protect the Gallup name. The new institute is the only authorized Gallup representative in Norway and thereby the only institute that has the opportunity to conduct Gallup-surveys and present Gallup-results here in the country.

Gallup International Norge A/S has made an agreement of cooperation with NOI [Norsk Opinioninstitutt A/S] which will undertake all marketing work and technical preparation for all surveys that will be conducted.

AFTENPOSTEN has reserved the right to publish both political barometers and results of opinion polls about current issues posed by the new institute --all under the joint name Gallup/NOI/AFTENPOSTEN.

Following are examples of current studies which AFTENPOSTEN will present under this vignette:

- \* Political barometer once a month
- \* People's evaluation of prominent politicians' achievements
- \* Opinions on various ministers
- \* Opinions on the government
- \* Influx to and defection from the political parties

In addition, AFTENPOSTEN will undertake opinion polls about current topics and most likely by posing many questions about the special topic in order to be able to give thorough analysis. Along with every published report, we will present the questions verbatim, the division of answers received from the pollsters and a short objective comment on the questions posed. It will be requested that all who want to comment further on the survey and draw conclusions, will do that with respect to this information. The objective is to try to prevent comments to be given for which there is no coverage.

The first results under this agreement will be published in September this year (before the elections), based on interview work done in August.

9583

CSO: 3639/149

## SOCIALIST-LEFT PARTY'S KORITZINSKY DISCUSSES POLITICAL GOALS

Oslo AFTENPOSTEN in Norwegian 27 Jul 83 p 3

[Article by Anne-Lise Hammer: "Shuttling Leaders: Socialist Left Party More Lively"]

[Text] It is not unobjective to appeal to emotions. In essence this is exactly what politics is, not 8 1/2 X 11 sheets and words, Socialist Left Party (SV) Leader Theo Koritzinsky says to AFTENPOSTEN. He has set himself the objective of making the SV a more lively party and this summer he is shuttling around Norway with a harmonica and melodica. In between summer camps and time at the party's office he has built a closet at his newly purchased residence in Sagene.

The SV's official election campaign does not start before 12 and 13 August in Sørlandet [the southern coast], but Koritzinsky has been on an "election campaign tour" right since the Sagene Teacher's College locked its gates for summer vacation. The newly chosen leader, who has been granted a two-year leave of absence from his teaching job, has given information about the election campaign platform and planks and has become acquainted with local SV dynamos and allowed them to become acquainted with him.

AFTENPOSTEN met Koritzinsky at Fauske in North Norway. The Erikstad Advanced School for Home Economics put up 50 party staff members in summer camp. There is heavy speculation in this county before the coming municipal and county board election. And besides, the party leader himself met the local population in Fauske, Sulis, Saltdal and Sørfold and half the Storting group for the SV. Hanna Kvanmo, who is from Mo, represents North Norway in the Storting and Arent M. Henriksen was born and brought up in the municipality of Sørfold, but represents South Trøndelag in the national assembly. At all summer camps it is a tradition to set aside one day to meet the local population and voters, Koritzinsky states.

Up to now he has joined the summer camp on Tromøya near Arendal and at Brandbu where there was a music and theater camp. The last three days of the peace march he is to go into Trondheim the coming weekend and after that Kristiansund, Alesund and Molde are on the party leader's itinerary. In between he can be found at the party office in Oslo. In a time when most parties have taken a political vacation in common, it is "full roster" in the SV and AFTENPOSTEN asked how Koritzinsky as the father of a baby and the leader of a party which goes in for 6-hour work days can justify such a working pace.

"No, it is a bit of a dilemma. There is too little time for the family. But after the election I am going into exile on vacation with my son, let us hope in order to celebrate a success for the party."

Together with Party Secretary Erik Solheim, Koritzinsky had considered advancing a recommendation regarding the 6-hour day at the party office, but they dropped it when they realized that the suggestion would get only two votes in the central committee. "But party work must not become just paperwork. It is fatal for a radical party to lose contact with the problems of ordinary people," Koritzinsky says.

When he was chosen leader after Berge Furre, it was said that he was one more intellectual in the leadership of a party which directs itself to workers. When Koritzinsky talks politics it is easy to note the theoretical schooling, but perhaps mostly because he ventures to show that politics is complicated when one looks behind the slogans. Before he became a teacher at Sagene Teacher's College he taught as a lecturer at the university in Oslo, first in political science and later in sociology.

In a coffee and smoking break Koritzinsky and Henriksen had a chat with AFTENPOSTEN regarding North Norway's future. This conversation resulted in big headlines in news reports: The SV supports civil disobedience and will demand a plebiscite against the deployment of nuclear weapons!

What was said was still more nuanced. Among other things, that the campaign against nuclear weapons somewhat resembles the campaign against EC. It is the same forces which are being mobilized and the characteristic thing is that the political elite are moving out of step with public opinion. When this happens we get acts of disobedience, Koritzinsky says, and the SV will support this. "But in addition to the fact that Norway is not to be included in the deployment of missiles, this will primarily be a matter of moral support for actions in countries in which deployment is actually to take place."

To the question of whether the SV will demand a plebiscite, the party leader answers that this can be a possibility but in this case the question to be voted on will become a problem because it will be necessary to take a position on a resolution in NATO. The SV will in any case demand a vote in the Storting before the Norwegian government is to declare its opinion regarding a missile agreement in NATO. "We will possibly overthrow the government on this question," is Henriksen's comment.

In spite of his theoretical background, Koritzinsky has set himself the goal of making the SV a livelier party. Hand in hand with the political message, there is to be a carnival, action theater and music. "We are not to be a socialist celebration party, but we must learn to effect politics so that they hit people at home. It is non unobjective to appeal to emotions. In essence it is what you believe in and who you take the party to be which is politics, not 8 1/2 X 11 sheets of paper and words," an engaged chairman says, who asserts that one does not break with intellectual claims by living by this, for the party will insist on requirements of objectivity and versatility.

"Willoch," Koritzinsky answers when AFTENPOSTEN asks about who he considers the most capable in the government's college. "His strength--and weakness--lie in the fact that he translates an opinion into a technical question. What Willoch really does is to think and feel; the incredible thing is that you journalists let him get away with it."

Koritzinsky also brings up names like Gunnar Garbo and Bergfrid Fjose. "They are politicians who dare to change their point of view and live with the times."

And this is exactly how one can characterize the SV's leader also--he lives with the times. He literally speaking helps his party hit the right note. He accompanies songs on the piano and plays banjo and melodica, not to forget the harmonica. He is indeed the only party leader who has received training from Tommy Reilly and Sigmund Groven themselves publicly on television.

And Koritzinsky has been on television before also. He himself maintains that as newly elected chairman of the Socialist Left Party he was most known for not being known. But he represented the Socialist People's Party in an election debate against the Liberal Party as far back as 1967 and got Bent Røiseland to come with the famous words "No gas," when he was provoked to say what weapons he thought the Americans should not use in Vietnam.

Sixteen years later he will appear in the studio again on the program "The Parties Answer," which, as far as the SV is concerned, will be broadcast from Bodø. Hanna Kvanmo will handle the party leaders' debate. Koritzinsky is a little nervous; what if I do not have the day!

8985

CSO: 3639/153

## STORTING FOREIGN AFFAIRS COMMITTEE TO VISIT CENTRAL AMERICA

Oslo AFTENPOSTEN in Norwegian 28 Jul 83 p 4

[Article: "Foreign Affairs Committee to Central America"]

[Text] The Storting's Foreign Affairs Committee plans for the first time in history a 14-day trip to Central America in order to familiarize itself with the political conditions in this new political focal point, the Liberal Party's press office reports. According to the provisional itinerary in January, which has received the all-clear signal from the Foreign Affairs Ministry, it is the intention first and foremost for the committee to visit Mexico. The country is one of the key countries in the area and as are several of its neighbors, is in a profound economic crisis. The other countries indicated on the itinerary are Costa Rica, Honduras and Nicaragua. (NTB [Norwegian Wire Service]).

8985

CSO: 3639/153

## MOTA AMARAL: AZORES NOT ONLY A MILITARY FORTRESS

Lisbon EXPRESSO REGIOES in Portuguese 30 Jul 83 pp VIII-X

[Excerpts] "To invest in the Azores is not throwing money into the sea, as some claim," the president of the Azores Regional Government, Mota Amaral, told EXPRESSO during an exchange of impressions we had in Ponta Delgada in government headquarters.

The statement was made in defense of the Azorean executive's positions regarding the funds provided in the General State Budget, which this year amount to about 2.8 million contos to be granted in quarterly portions plus the amounts granted by the "insularity statute," not yet accounted but which the previous year amounted to 1.5 million contos.

At the same time, Mota Amaral considered that the Azores Autonomous Region cannot be understood apart from the over-all context of the country and that the social and economic backwardness that it is suffering will have to be faced in terms of recovery at the risk of the cleavage that separates it from continental Portugal becoming wider.

"Since continental Portugal is already situated at the tail-end of Europe, we cannot permit the Azores to become separated even more," emphasized that politician in the interview he granted at our request.

Meanwhile, although the financial situation of the region is not brilliant, nevertheless, it is not one of failure or bankruptcy, Dr Mota Amaral told us, declaring with some humor that "on the continent, everybody believes that it is the Azores that runs a deficit, that it is the Azores that causes a loss. That is the constant complaint of the big public enterprises to justify their financial difficulties."

Negotiations With the United States: a Little More in Counterpart Compensation

"The Azores cannot be viewed only as a military fortress," underscored the president of the regional government as soon as we spoke to him about the negotiations pertaining to the Lajes Base and the U.S. military presence in the Azores, which is translated into other facilities granted to the NATO bloc in the archipelago.

"With these negotiations, we are seeking a little more," Mota Amaral told us but evading the "how much" that we wanted to know. "We believe that \$20 million per year is not sufficient compensation for U.S. plans, which envisage renovation of the facilities and expansion of the fuel depots, among other strategic concerns.

And while the negotiations go on--which also have to do with counterpart compensation of a military nature that the central government and the armed forces are taking to the discussion table--Mota Amaral pointed out that the Azores Region has no need to live on subsidies; rather, he is seeking investment in a start-off phase that is aimed at economic (and by extension, social) development, without which there are no guarantees of political stability.

"Backwardness and poverty are the culture medium of revolutions," pointed out the president of the Azorean executive, stressing immediately afterwards that "development is the secret;" development partly achieved and partly being implemented through the application of the proceeds from the aforementioned facilities and the respective counterpart compensation from the negotiations with the United States.

In that regard, various points of the regional government's development program are being implemented, applying the dollars from the United States and the escudos from the General State Budget in the expansion and reconversion of port and airport facilities, a network of school buildings, modernization and expansion of public health structures, construction of a new hospital in the city of Horta on the island of Fayal, a road network that involves the opening or improvement of highways, a housing program devoted to the construction of more hearths; also support for agriculture-livestock, implementation of a slaughter, refrigeration and storage network, etc; a program that is aimed at overcoming the "extreme shortages" that occur in the Azores.

The head of the local government considers that the region is no less lacking in energy, specifically in the area of electrification. In recent years, the consumption of electricity has increased exponentially and the local authorities are seeking new energy sources to meet the needs. One of them, geothermal energy, is already being experimented with on Sao Miguel Island and within some time may provide a substantial part of the electric energy.

All of these undertakings, said Mota Amaral, are provided for in the medium-term development plan that ends next year and the regional government is already working on the following plan, that is going to be in effect between 1985 and 1988.

Also with regard to the Lajes agreement and other facilities granted to the United States, we asked Mota Amaral how he views contrary opinions, specifically those that consider that military cooperation with the United States can endanger the region in case of a major conflict.

He replied calmly: "Portugal is a member-country of the Atlantic Alliance and the Azores are too important in strategic terms for fanciful wishes of demilitarization to be defensible. Let us not have any illusions about this because in case of conflict, the Azores would be occupied by one side or the other." So it is better for us to be defended by the military bloc to which the country belongs? "That's right," assented the head of the Azorean executive.

Separatism: Let it Appear Out in the Open

We then asked him another question: Does separatism exist; is it fact or fiction?

"Separatism is a latent issue. There is an Azorean nationalist movement in hibernation that is waiting for the opportunity to manifest itself," he replied. On the other hand, "if there are people who are seeking independence then let them appear so that the problem can be discussed openly."

And he pointed to the results of elections since 1975, all of them. There were always very clear indicators of the acceptance of the constitutional government in effect by "a wide and solid majority." And Mota Amaral emphasized the "social calm" that exists in the region built around the institutions that "gained credibility in the democratic process," proposing "Azorean solutions for Azorean problems."

Nevertheless, said that politician, independence is not a crime, bombs are. "But I am against laws that persecute separatism as an opinion," he added, explaining that in a democratic system, opinion cannot constitute a crime.

8711

CSO: 3542/195

## EANES, SOARES: QUESTIONS ABOUT 1985 PRESIDENTIAL ELECTIONS

Lisbon EXPRESSO in Portuguese 30 Jul 83 p 2

[Article by Pedro d'Assuncao]

[Excerpts] For the Socialist Party (PS), the support of the Social Democrats for the presidential candidacy of Mario Soares in 1985 is an accepted fact.

It remains to be seen if that expectation does not suffer from an excess of optimism. And the subject is particularly apropos at this moment because of all the controversy generated about the replacement of Garcia dos Santos as Army Chief of Staff.

In fact, it is known that Mota Pinto has confessed to various individuals his intention of supporting a military candidate for Belem Palace, an intention that would fully justify the care with which he had been dealing with the problem of military chief positions.

It is acknowledged that the vice prime minister had passed the information on to some journalists that he intended to wait for Melo Egidio to reach the age limit (which he will on February 1984) before touching the top military posts. That would lead one to conclude that the proposal for the resignation of Garcia dos Santos did not come from him but from Mario Soares himself--possibly to compromise the Social Democratic leader with the military men whom he wanted to treat with special care.

#### Soares-Mota Pinto, Contradictory Stories

In the meantime, this week a Soares aide hastened to circulate the story that the resignation of the Army Chief of Staff was demanded by Mota Pinto. And he went further: he affirmed that the socialist leader accepted it to prevent a government crisis.

It is true that it was the defense minister who suggested the replacement of Garcia dos Santos, at the Council of Ministers last Thursday--a replacement that had unanimous concurrence there, unlike what had happened in the executive of the AD (despite the fact that at that time Freitas do Amaral had based his proposal on immediate reasons). But it is also known that before the government plenum, he had discussed the matter at length with the prime minister, in private. And, strangely, there are also members of the defense minister's office who are accusing Soares of having been the only one responsible for the action.

## Surprise in an Atmosphere of Pressures

It is obvious that the surprise element operated. Except that the matter was far from having been forgotten. The heat generated by Melo Egidio's statements in Funchal was fully alive. And the most anti-Eanist communications media called on the government to take retaliatory measures.

There was still another reason that advised against generating a polemic in the military sector: the strategy that Mario Soares laid out with regard to Ramalho Eanes. That strategy aimed at placing the president of the republic in a secondary plane, changing the center of attention from Belem to Sao Bento Palace. And its implementation would require intense government action, avoiding relations with the presidency to the utmost (or its interference in the major issues of the state), but it would also require avoiding conflicts with Eanes that would launch him into the newspaper headlines.

## Eanes Returns to the Newspaper Headlines

Well, the Garcia dos Santos case caused all eyes to turn to Belem, in suspense for Ramalho Eanes' reaction, with an aggravating circumstance for the government: the lack of arguments that would justify its attitude (only unspecified political motives are mentioned).

For now, the displeasure of the army as an institution over the manner in which its chief was dismissed has been felt. As a matter of fact, last Thursday the main body of the general officers showed up at the Lisbon International Fair (FIL) at the side of Garcia dos Santos to accompany the visit that Eanes made there to the exhibit of this branch of the armed forces. The atmosphere was clearly one of a demonstration of redress. And even officers who did not harbor any special sympathy for the chief of staff were there (a typically military, cooperative reaction).

Several officers there stressed the need for the resignation of Melo Egidio in the event that the president of the republic approves the resignation of Garcia dos Santos (a resignation that, after the statements of the chief of staff in Madeira should come from him, himself). And in that connection, one of Eanes' aides said with very significant terseness: "That is a question that does not have to be posed for the time being because the president has not yet accepted the resignation of Garcia dos Santos." In any case, reporter Helena Mensurado of the PORTUGUESE NEWS AGENCY (ANOP) took the opportunity to ask Melo Egidio insistently if he intended to resign. And the reply was insistently evasive.

## Two Advantages for the Decision

In the meantime, the leaders of the government coalition will only derive two advantages from the resignation of the Army Chief of Staff: for Moto Pinto it is a forceful measure which could refute the numerous insinuations

about the lack of determination (and members of his office assert that other actions will be taken, of a similar spectacular nature and with the same objective); for Mario Soares (and all of his team) it would be a way of diverting public attention from more sensitive question such as the economic crisis, the negotiations with the IMF and the resolution of the ANOP case, among others.

That is why Eanes refused to discuss the military chiefs' positions with Mario Soares when the latter went to Belem last Wednesday. He informed him only that he would ask him in writing (the same method that the government used to inform him of the problem) to substantiate the decision. And he preferred to discuss precisely those questions with the prime minister.

#### Presidential Elections in the PSD Congress

Be that as it may--and if a difference of opinion in the case of the military chiefs' positions is not confirmed (which at least is not assumed by any of the sides)--everything is going well for the time being in the central block. The problems will only arise if it develops that the Social Democrats fail to support the candidacy of Mario Soares for Belem.

One thing seems more and more certain: the 1985 presidential elections will dominate the proceedings of the next Social Democratic Party (PSD) Congress early next year. The Balsemao-Mota Amaral-Salgueiro line will have already decided to follow a strategy that leads to the emergence of a candidate for the presidency from the party. Mota Pinto supports a military candidate. The Lisbon group, to which Marcelo Rebelo de Sousa belongs, opposing the central bloc, can hardly justify support for Soares, from the outset.

#### M. Pinto Approaches J. Salgueiro

In the meantime, in view of the distance separating personalities from the Social Democratic majority and the government, the Balsemao line again tries to extend bridges of understanding to Mota Pinto, bridges which became more solid last Thursday when the vice prime minister met with Salgueiro to inform him that he concurred in his election as leader of the parliamentary group (a concurrence that can also result simply from the recognition of the impossibility of contesting that position with the former finance minister).

On the other hand, negotiating on presidential elections with the PSD (as on any other major issue) always has one disadvantage: in the absence of an uncontested leader with the strength to control the various feelings, the matter has to be discussed in detail in the National Council or even in congress where surprises can always arise. For that reason, Mario Soares does not neglect to favor all the Social Democratic wings with his greatest charms.

But, according to a socialist minister, the danger of a serious contender to the PS leader emerging from the PSD does not exist. That minister told us: "Soares is in a position to win overwhelmingly over any military man. Mota Amaral is a candidate easy to attack because of the positions he adopted at the time when there was talk about the independence of the Azores. And after his defeat in the AD, Balsemao does not have the slightest possibility."

An optimism that aims to be embodied already in a dynamics of victory?

8711

CSO: 3542/195

## POLITICAL MOTIVES INVOKED FOR GARCIA DOS SANTOS ISSUE

Lisbon O DIABO in Portuguese 2 Aug 83 p 2

[Commentary by Jose Miguel Judice]

[Text] It seems obvious--and I have already written that--that the moment to replace Garcia dos Santos was immediately following the approval of the government program in the Assembly of the Republic. In a semi-presidential system and with a defense law that imposes joint decision, the replacement of the man who for political reasons was chosen by the president of the republic in the wake of the victory over Soares Carneiro is a political act of the first importance. And to postpone it does not render it commonplace inasmuch as the amplifying effect of the communications media only caused it to become even more important with the passage of days.

Since it had not occurred immediately after the entry into operation of the government, it could not have failed to occur before Army Day. Political decisions have to be symbolic. It is possible, meanwhile, to think otherwise and to say that it would have been more polished to let a few days go by and not make things coincide. However, that is not the problem. What matters is to discuss the decision to propose the dismissal of Garcia dos Santos and to adopt a position on it and not camouflage that issue with the concentration of interpretative effort on topics related to the "timing" of the position.

#### An Inevitable Proposal

Garcia dos Santos was chosen by Ramalho Eanes at a time when he was still chief of the Armed Forces General Staff and on the eve of leaving that position. And he was chosen despite (or especially because of) the fact that he did not belong to one of the classic branches of the service and did not really have a military background. And he became Army Chief of Staff following several years in Belem as the person institutionally closest to the president of the republic. Garcia dos Santos was chosen for political reasons, as a way of showing the military, who by tradition and training look very much to the real power, that in him--Eanes--resided the power to make it rain or shine on the armed forces, despite leaving his military functions.

Like that husband in the classic story who beat his wife especially when he had no reason to do so because only in that way could she understand who was boss, Ramalho Eanes, with some Machiavellianism, chose Garcia dos Santos precisely because of the various choices possible, his choice was perhaps the least justifiable. Analyzing the government's decision has to start from the recollection of that fact.

But not only that. It is also necessary to keep in mind that the crucial political issue last year was undoubtedly the paraconstitutional question in the matter of defense. A prudent politician, such as Ramalho Eanes has become accustomed to being, did not hesitate to issue a veritable pronouncement through Letria, as we may recall, trying with the threat of atomic war--which would be his resignation--to lead the Socialist Party (PS) to support entrusting to the president of the republic the exclusive powers in the area of selecting and dismissing the military chiefs.

Letria was not replaced--and that in itself is a political fact--the socialist deputies were not frightened and there is no doubt that General Ramalho Eanes and everything he represents (or everyone through whom he expresses himself) were against the solution that was formalized in the defense law, in the matter of government powers over the military chiefs' positions. And he wanted to mark that disagreement through a veto that, it was already known, would not change anything, which lends it even greater political importance, as is obvious.

The government crisis that followed the elections for autonomous governments had the consequence of reinforcing the factual power of Ramalho Eanes. The choice of Baiao Horta as defense minister, known to be a Belem man and an absolute layman in military matters, further accentuated the feeling that, counter to the defense law, it was General Eanes who ruled in the armed forces. It was important to show that that was not so because it could not be so, according to the constitution and the legislation in effect.

And to conclude, it is well to keep another fact in mind. And that is the "25 April Association" made up of active and reserve officers to which Garcia dos Santos and Ramalho Eanes himself--it seems--belong. That association is objectively a political-military pressure group that is organized within the barracks, controlled by political military men who are prolonging the Council of the Revolution and has as its ultimate objective restoring the sociological conditions so that the Armed Forces Movement (MFA)--as the vanguard of an army which itself is self-styled as the popular vanguard--can again control the nerve centers of military decision

It is certain that some unwitting dupes are also members of that association, which was deserving of a piece of writing by Garcia Marques, in this case not lodged in fantastic realism. But the fact is that in armed forces with a crisis of identity and objectives, with insecurity

about correlations of force, keeping Garcia dos Santos would at least mean that having one foot in the "25 April Association" would become one of the conditions for promotion, unwritten but no less important because of that.

Proposing the dismissal of Garcia dos Santos has to have to do with that and only has to do with that. The subordination of the military to the civil power at this precise historical moment demanded it. And for that reason, it is unimportant to discuss the intelligence of Garcia dos Santos or the apparently bizarre matter of a bank forgetting for years to sue him as coresponsible for a bank debt. It is a matter of indifference to see if he took correct measures in military matters or whether he did or did not place men of unquestioned military capability in positions of responsibility. The decision was political and as such has to be assumed, nor is it worthwhile as far as the government is concerned to be doing a lot of justifying. For, can one not see, by who is protesting, whom it displeases?

What Will Ramalho Eanes Do?

But the confused defense law that is was possible to obtain obliges Ramalho Eanes to decide on the government's dismissal proposal. Three courses are open to him: the first is refusal pure and simple. The second is the dismissal pure and simple, although in both cases camouflaged with some arguments. The third is negotiation of Garcia do Santos' departure with some compensation.

I am convinced that Ramalho Eanes is going to opt for the third solution and, to conclude, perhaps it is worthwhile analyzing the other two. To refuse the dismissal would have as an obvious consequence the obligation of Maria Soares to set the question of political confidence and asking for resignation. As a matter of fact, if the government agreed to "swallow" Ramalho Eanes' refusal, it would be showing that it is weak, did not have power in the armed forces, did not even have the prudence not to enter into conflicts that it could not win. In politics, the essential thing is to reveal ability and strength. Governments that lose a battle and complain that they do not have the means to win it for reasons of a legal nature do not go far.

And the only consequence of the fact that the government delayed the measure for several weeks is that it will not even be able to mask a retreat with the argument that it has only wanted to establish a position of principle. For that, it would not have been necessary to wait so long. Since the government cannot fail to ask for the resignation--and Ramalho Eanes cannot be unaware of it--the refusal to dismiss would place the president in a dramatic situation which would be not giving the government the possibility of directing the armed forces under the terms of the defense law and thus open up a serious political crisis.

The second alternative is understandably not desired by the president of the republic. For him, power over the armed forces continues to be the appropriate instrument to try to obtain more powers. It is the reserve terrain, the field for combat preparation, the implicit threat that can make the adversaries fear. To accept the resignation can reveal dignity, can reveal a sense of state, can reveal moderation. But it does not reveal power.

The third alternative can be subdivided into two subhypotheses: The first is the attempt to add another chief of staff to the list of dismissals, which the government obviously will not be able to accept because it is too apparent. Or it can be the attempt to generate a replacement for Garcia dos Santos who will sail the same waters or who, because of his weakness and indecisiveness, can be manipulated. And it is along that course that Ramalho Eanes is going to try to act.

For that reason, the political question now is no longer the dismissal of Garcia dos Santos but the matter of his replacement. And in that regard, it will behoove whoever has the duty of proposing three names to be the government to choose militarily prestigious names, professionally qualified, politically determined and without illusions about the natural goodness of people or with the tendency to accept the "national folly" which, in the armed forces takes the form of the complicity of "school chums." It is essential that the army have an excellent Army Chief of Staff. And the government must have the courage to propose him if he appears among the names designated.

8711

CSO: 3542/195

## PEACE FESTIVAL SUFFERS FROM REDUCED ATTENDANCE

## PSD Youth Absent

Lisbon POVO LIVRE in Portuguese 27 Jul 83 p 1

[Excerpts] The National Political Commission of the JSD [Social Democratic Youth] decided to withdraw from the organization of the Provide An Opportunity for Peace Festival, in the belief that it represented "nothing more than a vulgar PCP [Portuguese Communist Party] demonstration."

This decision was adopted at a meeting of the political commission of the youth organization of the PSD.

The JSD justified withdrawal from the organization of the festival with the statement that it "has moved away from its original goals" and that the PCB took control of the organization process "to confuse the message of peace with an anti-Western and anti-European message."

"From the effort to expel the JSD members from the organization commission and the suspension of publication of the festival bulletin, to the insistence on issuing an invitation to Mr Costa Gomes, an individual directly linked with the pseudopacifistic maneuvers of the USSR in Eastern Europe"--these are some of the charges made against the organizers of the festival by the young social democrats.

A statement issued at the conclusion of the National Political Commission meeting said, however, that the JSD "sets forth its desire to resume all the undertakings it deems appropriate for the defense of the ideals" of peace, inviting the participation to this end of "all those who showed great moral and political dignity in this process, regardless of their ideological affiliation."

## Foreigners Barred

Lisbon AVANTE in Portuguese 28 Jul 83 p 5

[Text] Adopting an unspeakable attitude and directly violating the spirit and the letter of the Constitution, the PS [Socialist Party]-PSD [Social Democratic Party] government, through its Ministry of Foreign Affairs, headed by Jaime Gama, ordered that six young foreigners who came to Portugal to participate in the Troia Festival be held at the airport and later that they be

expelled from the country, since, without any logical justification, the Portuguese authorities rejected their applications for entry visas.

The six young people in question came to our country as representatives of the World Federation of Democratic Youth. They are natives of Czechoslovakia, the GDR, Grenada, Colombia, Yemen and Cyprus.

The organizers of the festival called on the ministries of foreign affairs and internal administration without achieving any satisfaction, while also publicly denouncing the serious situation created by the government.

Meanwhile, in a letter sent to the heads of those two ministries on Monday, the president of the PCP [Portuguese Communist Party] parliamentary group, Carlos Brito, stated:

"I have just, accompanied by my comrade, deputy Jorge Patricio, visited the six young foreigners who have been detained since yesterday at the Lisbon airport because they were denied entry into our country...

"The young people came to participate in the youth festival scheduled to be held on the subject 'provide an opportunity for peace' in Troia.

"I was told that with the exception of the Cypriot, all of them applied for their visas some weeks ago at the Portuguese Embassy in Budapest, which even told the Colombian youth that he did not need a visa.

"It is almost unbelievable that a situation like this could occur in the Portugal which emerged following the 25 April revolution.

"What is happening is a symptom of a worrisome governmental sectarianism, disrespect for the spirit and the letter of the Constitution of the Republic and a violation of the basic principles of human rights. It is seriously affecting the prestige of our country abroad.

"While addressing to you, Mr Minister, the vehement protest of the PCP parliamentary group, we insist in the name of all of the democratic values which are at stake on the need for a prompt alleviation of the situation of the young people, along with authorization for them to enter Portugal."

The government also made participation in the festival impossible for 25 of the 30 young Soviets who were to be included in the delegation, eight of the 10 Bulgarians, and yet another Colombian delegate who was prevented from crossing the frontier at Marvao.

The government of Mario Soares thus made its "contribution" to the campaign of slander and the effort to cancel out the major importance of holding the festival, frustrated maneuvers in which the protagonists were, for example, the right-wing newspapers and the JS [Socialist Youth] and also the JSD.

5157

CSO: 3542/189

## PRESENT STATUS, AMBITIONS OF RIGHT-WING SECTOR ANALYZED

Lisbon EXPRESSO in Portuguese 16 Jul 83 pp 14R-15R

[Article by Joao Carlos Espada: "Where and What the Portuguese Right Wing Is"]

[Excerpt] The memory of 48 years of dictatorship and the strong leadership of Oliveira Salazar still dominates, to a large extent, the difficulties encountered by the Portuguese right wing in political and ideological adjustment. And the most obvious evidence of these difficulties is the lack of any single large parliamentary party which specifically claims right-wing affiliation.

However, the right wing exists--here as in any other country--and this is certainly not true only "for the right wing of the CDS [Social Democratic Center Party]."

This is precisely what Marcelo Rebelo de Sousa noted in recalling that "the right-wing families are shy about terming themselves that because the democratic regime was born under the sign of the left wing, and this has given a bias to political labels."

There is a kind of "semantic defense," as Adriano Moreira calls it, resulting from the "dominant preoccupation with whether people were linked with the old regime or not."

The truth, according to Borges de Macedo, "is that the Portuguese right wing supported the New State, but the latter was not very sensitive to the creation of alternatives."

"It forgot that the logic which threatens authoritarian political regimes is not that of the political enemies, but that of internal contradictions and strangulations. And the regime fell, not because of leftist opposition, but because of its own difficulties, specifically due to the war," he adds.

#### Right-Wing Sectors

But will there really be a democratic right wing in Portugal, one capable of freeing itself from authoritarian collectivism and of playing a political role it assumes as its right?

In the view of Gomes de Pinho it is obvious that a distinction must be made between "a historical right wing, what one might call traditionalist, and a modern right wing."

He explains that "the former is created by opposition to socialism and the historic left, while the second is born of recognition of the failure of socialism--it has a Christian democratic matrix and a liberal component."

Marcelo Rebelo de Sousa, as will be explained farther on, extends the concept of the right wing to the interior of social democracy itself, in the Portuguese case, and within the PS [Socialist Party] itself.

In his view, there are three major right-wing families:

"There is the antidemocratic group, nurtured in the most reactionary sectors of the old regime," with which he associates the MIRN [Independent Movement of National Reconstruction], the PDC [Christian Democratic Party], the newspaper O DIABO, etc. "Then there is the centrist right wing of the Giscard d'Estaing stamp, which includes a part of the CDS and the PSD [Social Democratic Party], which is related to "Marcelism" in government. Finally, there is the social democratic right wing, which covers a part of the PSD and a part of the PS, and which includes elements from among the liberal "Marcelism" sector and the democratic opposition.

The difference between the second and the third would lie only in the distinction between "strictly neoliberal and social democratic positions."

In the view of Borges de Macedo, on the contrary, what we have is a powerful right wing which maneuvers, without doctrinary positions, and brandishes short-term slogans without global scope. And he cites the reestablishment of private banking, for example, which he regards as indispensable, but which he says does not in itself define a program. We do not have a European right wing, like that of Margaret Thatcher or Chirac, and this would have to be due in large part to the leftist complex of the maneuvering right wing, its continuing fear of public opinion, which would lead it to want to avoid being identified as a doctrinary right wing.

#### Lack of Program Definition

This is to some extent the concept of Cunha Rego, who accuses the CDS and the PSD of not being right-wing parties, "although they represent economic and social interests linked with what is sociologically called the right wing."

Cunha Rego stresses that the Portuguese right wing lacks an overall doctrine, mainly in the economic sector, which prevents it from directing the path of events.

"Sa Carneiro had a glimpse, but yet he did not have an overall doctrine. But there was a possibility of finding this doctrinary path, had he survived. Following his death, the right-wing parties turned into interest lobbies."

The conviction that there is no ideological classification for the Portuguese right wing was shared by almost all of those we interviewed. Jaime Nogueira Pinto stressed that the hegemony of the left wing in political language and classification led to a curious phenomenon. "The CDS and PSD voters are to the right of their leaders, and their leaders are to the right of their programs."

Borges de Macedo, in turn, extended this lack of definition to all of the Portuguese parties in general. "None of the basic aspects written into the party programs is to be carried out. They are almost exclusively the product of the timeliness of having stated them at a given point. Now if the programs are not viable, this necessarily gives rise to a high percentage of opportunistic support."

"The parties come to power to implement the programs of others," Rebelo de Sousa confirms. "The AD [Democratic Alliance] itself, which was close to neoliberalism, implemented a much less neoliberal program than the present PS-PSD coalition."

#### Economic Doctrine

Marcelo Rebelo de Sousa and Vitor Cunha Rego therefore specifically defend the need for a redefinition by the large Portuguese right-wing families. Borges de Macedo, Franco Nogueira and Nogueira Pinto also subscribe to such a need, but their statements are less incisive on this subject.

Cunha Rego stresses the urgency of clarification, with disturbing pessimism:

"The economic problem is the Achilles' heel of the Portuguese right wing. It does not have a doctrine in this sector, beyond the defense of the state as the supreme arbiter of conflicts."

Simultaneously, Cunha Rego states that the black market economy in Portugal tends to be the support of political action by the right wing, "for the simple reason that it is the only economy which is not yet bankrupt." And he adds: "The black market economy wants to defend its interests and to white-wash its semiclandestine operations, and although it may speak in the name of the state of law, I doubt that it truly defends it, since it has no philosophy of its own."

Speaking deliberately, with acute bitterness, Cunha Rego concluded: "If we do not succeed in returning to the path along which the AD embarked (the sponsorship of a federation of ideas, persons and interests representing a modern right wing in this country), we will be running the risk of having the black market economy impose its system on the country, and there I fear that we will have a system in which financial capital prevails, and which therefore moves toward fascism.

"With our class of politicians," he further added, "clarification and a clear policy will be difficult. There is an abundance here of individuals who, knowing that Portugal will be short of water, are not excessively worried because they believe they have pitchers enough in their own homes."

### Three Paths

In the view of Marcelo Rebelo de Sousa, it is essential that the right-wing families reorganize themselves. "It would be desirable to have the social democrats grouped in a single party, and the conservatives and neoliberals in another. This would make it possible to stabilize the regime with a two-party alternation system. But there are many obstacles resulting from the traditions of the present parties, the economic crisis, and the very resistance the Constitution imposes against a change in the electoral system, etc. Therefore the essential task today is contemplation and clarification within each party."

This is why Rebelo de Sousas stresses that there are those who have abandoned this clarification, accepting the present situation as inevitable, and therefore placing their bets on a president who will intervene on a supraparty level.

"This is the presidentialist dream shared by the right and left wings, but which I believe entails many threats to democracy," he comments.

Finally, there is further, in the view of Marcelo Rebelo de Sousa, a third group, those who rely on the central bloc as the pole around which a social democratic family can rally.

"But all of this occurs in confused fashion, without leading to clarification either in the PSD or in the PS, with the adoption of a government program which is more neoliberal than social democratic, etc. It is practically certain that it will not succeed."

However, Adriano Moreira is more cautious about predicting the future. He recognizes that "since the PS abandoned Marxism, we remain with two social democratic parties which differ in history, traditions, style and leadership." And he asks: "Will this give birth to a social democratic family? The prognosis is difficult."

### Necessary Clarification

In fact, there is a need for political party clarification, and if two parties are hypothetically close in a social democratic sector, why wouldn't there be a right to utilize the present coalition to encourage that clarification?

The possibility would be the more viable since Adriano Moreira and Gomes de Pinho, of the CDS, agree in stating that their party "is likely to rally the Christian democrats, the main component, the conservatives of the Chirac and Thatcher stamp, and the modern liberals or enlightened capitalists, as the Americans prefer to say."

Cunha Rego is the main dissident with regard to this solution. First of all because he believes that "political clarification in Portugal has involved

the clear principle of alternation in power, which this government has destroyed." This is, in the final analysis, the view shared by Jose Miguel Judice and Marcelo Rebelo de Sousa.

"The formation of a cartel of parties with social democratic programs," Cunha Rego adds, "not only is ill-adapted to the so-called objective conditions, but would prevent such a modern right-wing federation (which he calls realistic and romantic), while at the same time preventing such a federation of a realistic left wing."

On the other hand, Cunha Rego goes on to say further, "this coalition was created with two purposes which have nothing to do with political doctrine: the presidential candidacy and the occupation of the political space of the Eanist movement."

Borges de Macedo, in describing the PSD, for example, illustrates what he means by lack of clarification.

The PSD, he says, is "above all a middle-class party persuaded of the need for a social contract, a mobile society and constant advancement. It has, beyond this, a radical anticommunist inclination which nothing succeeds in modifying, however many blunders its leaders make. These are positions which are in no way specifically right- or left-wing, because it is entirely true that there is a right wing which collaborates with the communists and the left wing which refuses to do so."

And he concludes: "The PSD has a leftist social program, but the awareness of the real dangers threatening this project very often cause it to adopt right-wing positions." This would also, in the view of Borges de Macedo, confirm the confusion which may result from the indiscriminate maintenance of the left wing-right wing dichotomy.

#### A Future Right-Wing Government

If political party clarification is so difficult, what is the situation with regard to a future right-wing government program?

There appears to be agreement among those we interviewed on only three basic points: the need to reestablish the authority of the state, to dynamize private enterprise and contain public expenditures, to safeguard our national identity and to promote relations with the Portuguese-speaking countries.

The program seems similar to that of the present coalition. Cunha Rego admits, moreover, that "the present executive branch is more representative of dramatic political debate, which would be characteristic of the right wing, than the preceding one. But within 6 months or so, the tone of the government will return to pacification and optimistic recovery."

"And the real problems will remain to be resolved," he emphasizes.

Gomes de Pinho, however, believes that the present coalition cannot undertake the "necessary modernization of the productive structure and social relations because, as a government of the left, it excludes any expectation of a social rise for the expanding intermediary sectors which are basic to reviving the nation."

Franco Nogueira, for his part, believes that the basic problem with which the right wing would have to deal is that of the Portuguese "political practice."

"There is no constitutional problem," he explains, "since the Constitution, since its revision, makes it possible to govern from the right, the center or the left. But there is a defect in the functioning of the institutions which interferes with governing the country. There seems to be a prevailing mediocrity which expels the competent men or submerges them. There is a lack of integrity, sincerity and firmness on the part of our government leaders, which leads to lack of credibility."

#### European Economic Community

Borges de Macedo continues to believe that there is a need for a revision of the Constitution such as to remove from it all of the prosocialist ideological content.

But his main emphasis is on the need for a national economic program.

"The economy cannot be revived purely on the basis of free competition, because this would eliminate the national economic program. Its reestablishment must be based on an economic liberalism which gives an advantage to domestic agents without destroying legal equality. It should not lead to organization of the enterprises as they want, but rather as the country needs, and they must respect the trade union bodies provided they act outside the political realm."

Finally, Borges de Macedo believes that there should be "aggressive development of the capacity of Portuguese products to compete on foreign markets, to do which it is necessary to cease to make all of our economy dependent on membership in the EEC."

"Membership in the EEC is a program neither of the left wing nor the right wing, but of politicians as a class," he believes.

Cunha Rego notes that, from his point of view, there is no right-wing economic doctrine in Portugal. And he emphasizes that, lacking such a doctrine and since the deterioration of the socioeconomic situation is predictable, "it will be difficult to avoid either the present type of government or a totalitarian venture, of either a left-wing or right-wing sort."

Therefore, he reiterates the need to resume the path on which Sa Carneiro embarked in order to clarify the political families.

## TRIAL OF SARAIVA DE CARVALHO POSTPONED

Lisbon O JORNAL in Portuguese 29 Jul 83 p 10

[Text] The trial of Otelo Saraiva de Carvalho, which was scheduled to be held yesterday, Thursday, in the Evora Court, was adjourned and rescheduled for 4 October at the request of the lawyer for the defense, Dr Manuel Salema.

Since the new Penal Code does not list the crime with which Otelo is charged, Judge Antonio Ferreira de Almeida, the presiding judge, did not in fact see any hindrance to the petition by Dr. Salema.

Otelo is charged with "incitement to violence," which crime he is said to have committed in Evora during a clarification session held by the Popular Unity Force (FUP) at the Garcia de Resende Theater in March of 1980.

According to the charges filed by the public prosecutor, the former commander of the COPCON [Continental Operations Command] addressed a full hall, urging the workers to engage in forms of political struggle based on violence, with the justification that the violence of the regime merited a violent response from the workers. Otelo then proposed a mass march of the workers from Alentejo to Lisbon in defense of agrarian reform, according to the public prosecutor's office.

Yesterday, Otelo Saraiva de Carvalho was hailed as he entered the court by tens of individuals who, according to an ANOP report, shouted "Long live 25 April," "Long live Comrade Otelo," "Death to fascism," and "Liberty will triumph." When the hearing room was full, the crowd began to shout "The 25 April movement, not Otelo, should be tried!" Court officials asked that PSP [Public Security Police] troops be present, but no incidents ensued.

As is known, the president of the republic recently presented Otelo Saraiva de Carvalho with the Order of Freedom.

5157

CSO: 3542/189

## BRIEFS

PLANNING OFFICIAL RESIGNS--Cavaco Silva, the illustrious economist and minister of finance under Sa Carneiro, resigned his post as president of the National Planning Council because, he said, of mistrust of this body on the part of government leaders and the lack of legislation suited to its functions and representative nature. It is earnestly and confidently to be hoped that Prof Cavaco Silva will now have his hands free to be able to diagnose and propose solutions for our economic problems. [Text] [Lisbon A TARDE in Portuguese 28 Jul 83 p 24] 5157

USSR DELEGATION DEPARTS--A delegation representing the Transportation Workers Trade Union of the Soviet Union ended a visit paid to Portugal at the invitation of the FESTRU yesterday. The Soviet delegation, which included trade unionists Viktor Gorkin, Nikolay Trofimov and Mikhail Matsan was officially welcomed by the FESTRU and the CGTP-IN [General Federation of Portuguese Workers/National Intersindical], and made a tour of the southern part of the country at the invitation of the Southern Farm Workers, Faro District Highway Transport and Southern Highway Transport Trade Unions. They also visited the National Highway Transport and Railroad Workers Unions, in Faro and Lisbon, respectively. Following a joint working session, the Soviet transport delegation and the secretariat of the FESTRU stressed the importance of deepening bilateral relations and increasing cooperation, above all in the vocational and trade union training sector and in mastery of health and safety at work and during leisure time. The two delegations further agreed on the need and importance of encouraging those activities leading to international clarification, peace and cooperation. [Text] [Lisbon DIARIO DE LISBOA in Portuguese 27 Jul 83 p 16] 5157

ALADI MEMBERSHIP--Portugal was admitted as an observer-member of the Latin American Integration Association (ALADI) by the unanimous vote of its Committee of Representatives and becomes the second associated European country following the admission of Spain last November. After the approval of the admission of Arturo Gonzalez Sanchez, expressed his satisfaction over the new expression of adherence to the process of integration of the continent by a European country. ALADI will hold the sixth period of special sessions between 22 and 26 August in Montevideo. [Lisbon DIARIO DE NOTICIAS in Portuguese 29 Jul 83 p 3] 8711

## PCE-EPK OFFICIAL INTERPRETS BASQUE POLITICAL CURRENTS

Madrid MUNDO OBRERO in Spanish 22-28 Jul 83 pp 14-15

[Interview with Ignacio Latierro, secretary general of the PCE-EPK, date and place not given]

[Text] Felipe Gonzalez' meeting with Carlos Garaicoetxea is taking place at a particularly difficult time. The position of confrontation between the Basque government and the government headed by Felipe Gonzalez, and between the parties which support each of them, has intensified--perhaps because of the already imminent elections in the Basque Country. Although the date has not been finally confirmed at this time, there is little reason to be optimistic under the circumstances, when the ETA [Basque Fatherland and Liberty Group] appears to be intensifying its armed struggle, and the "lack of understanding" between Madrid and Vitoria is increasing so rapidly. In order to learn more about what the situation is these days, we interviewed Ignacio Latierro, secretary general of the PCE-EPK [Spanish Communist Party-Basque Communist Party]. His remarks could be helpful in understanding the difficult situation which--in his opinion--is bringing about what he calls a lack of a desire for a political understanding.

[Question] In recent days, along with the new actions by the terrorists, some disturbing events have taken place in the Basque country. I am referring to what happened in the Irun and Tolosa Town Councils. What is the political and social climate in the Basque Country today?

[Answer] Well, recent events in the Basque Country only continue the climate of confrontation between what we could call the "nationalists" and the "anti-nationalists," which has already been so apparent in Basque life for too many months.

In this sense, I may venture to say that the Basque Country is on the verge of a deep split within its people, is in the midst of a serious economic crisis, and has the added problem of terrorism. We think that the PSOE's [Spanish Socialist Workers Party] policy--or rather the lack of a policy--toward the Basque Country, of a socialist government policy regarding the Basque Country, also contributes to this deterioration of the situation; as does the accentuation of the more exclusivist, more intransigent tendencies of the Basque nationalists, which is furthered by this absence of a government autonomies policy. Well, that would be the first answer.

[Question] What does the EPK think of the autonomies policy of the PSOE, especially regarding the Basque Country?

[Answer] We think that in its autonomies policy the socialist government is a prisoner of the agreements which it signed 2 years ago, which are known under the name of LOPPA. [Organic Law for Harmonization of the Autonomies Process] These were signed with the UCD [Democratic Center Union], but they really were signed with someone else, and they are completely determining its present autonomies policy. In fact, the Socialist Party is not demonstrating a desire to further the cause of Basque autonomy. I could give one story as a very important example: how 15 or 20 days after the press had released with great fanfare the announcement that the ZEN [Special Northern Area] was going to be a cure-all for the solution of political problems and the anti-terrorist struggle in the Basque Country, the Basque government still had not learned about that plan. This is an example of the central government's lack of any real spirit of cooperation with the Basque government in attacking the most pressing problems of the Basque Country. Then there is the fact that in the area of legislative development, laws like the LRU or the LODE and other bills contain matters which go beyond what has already been approved by the Basque Autonomy Statute, to the extent that responsibilities are assumed which should belong to the autonomous parliaments in a good autonomies policy. Finally, there is a blockage on the subject of the transfers, because although it is true that on some topics the position of the nationalist government, particularly in the matter of social security, is quite debatable, however neither is there any sign of a will to unblock this on the part of the PSOE government. In any case, the basic problem is that of political will. This is a problem which concerns the relations between the government of Spain and the government of the Basque Country, but which also relates to the attitudes of the socialists and the Basque Country nationalists themselves. There, as I said before, the problem exists on the same level as the split within the Basque community itself, and where either we are capable of carrying on a policy of cooperation in which the two majority forces must be involved, or the problem will continue to worsen.

[Question] Regarding the current situation, what significance would you give to the meeting which has been announced between the president of the Spanish government, Felipe Gonzalez, and the Basque leader, Carlos Garaicoetxea?

[Answer] Within this context of confrontation, the truth is that it is difficult to expect any kind of immediate hope of positive results from the meeting which has been announced between President Gonzalez and the "lendakari" Garaicoetxea. In our opinion, this is more a case of a ceremony which is trying to alleviate tensions, which is trying to give an impression of less tension at a time when tension has reached very serious proportions. The problem is that both the PSOE and the PNV [Basque Nationalist Party] have already embarked on an electoral policy in view of the coming autonomous elections. Although this policy may be a harmful one from the point of view of the Basque Country's interest, however to the extent that it has managed to bipolarize the electorate since the 28 October elections and

in the municipal elections, it appears that both parties are prepared to maintain it, and not revise it, despite what it may cost them. There has been no new element in the previous conversations. Therefore, it would be an unexpected surprise if one meeting alone could change the course of events. And I also think that if the day should come when there really was a desire for change on the part of the socialist government as regards its autonomies policy, and therefore a wish to really further Basque autonomy, what would have to happen is that it would be President Gonzalez who would come to Vitoria to announce the news, and not Garaicoetxea who would go to Madrid.

8131

CSO: 3548/480

## POLL FINDS PEACE ISSUE SEEN AS INCREASINGLY VITAL BY VOTERS

Stockholm DAGENS NYHETER in Swedish 17 Jul 83 p 4

[Article by Sven Svensson: "Increasingly More Voters Rank Peace As Most Important"]

[Text] Employment is the overwhelmingly dominant political issue, but the issue of maintaining world peace is perceived as increasingly vital. This is the finding of the DN/IMU [DAGENS NYHETER/Institute for Market Research] poll taken during the spring regarding the two most vital questions that politicians "should work on."

During April and May, 1803 voters were asked to indicate which two political problems they regarded as the most important at the time.

Sixty-four percent of those polled (a record) said that employment is the most important question. In the spring 1982 poll, 61 percent said that employment was the most important problem, compared to 38 percent in spring 1981. During the referendum on nuclear power, energy was ranked by 43 percent as most important.

It is chiefly the voters in the block of socialist parties who say that employment is a vital issue. Seventy-four percent of these voters regard the issue as vital, compared to 61 percent of the voters in the middle-class block. The Social Democratic voters have the greatest interest with 75 percent.

#### The Economy Is Second

The economy occupies a clear second place in the poll. Thirty-one percent of the electorate believed in spring 1983 that the economy is a vital issue. That is the lowest reading since winter 1980, when 30 percent of the voters considered the economy a vital issue. The record reading was 56 percent in 1981.

It is primarily the voters of the middle-class parties who think the economy is a vital matter. Thirty-six percent of the middle-class voters versus 28 percent of the socialist voters mention the economy in their response. The Moderate Party voters are at the head with 41 percent.

The issue of the environment is in third place in the poll with 14 percent. This is a decrease since 1982, when the reading was 19 percent. The Social Democratic voters account for the highest figure, 29 percent.

#### Peace

World peace has come up to fourth position with 10 percent over against 4 percent in spring 1982. This shows that the discussion concerning deployment of new nuclear weapons in Europe and the submarine violations have affected voter opinion.

There are marked differences between the blocks. Six percent of the middle-class voters rank world peace as vital, compared to 13 percent in the socialist block. The VPK [Left-Wing Communist Party] voters are highest with 20 percent.

In the wake of the submarine violations, defense also made a gain. Five percent of the electorate consider defense a vital issue; of these, the Moderate Party voters show most concern with 9 percent.

In fifth place in the poll is the issue of taxes. Nine percent see this as a vital issue, a surprisingly low figure. The record reading of 19 percent occurred in fall 1979.

#### Energy Down

The energy issue dominated voter concern during 1979/1980, with readings at 43 percent. This concern has since declined steadily. The figure stands now at a record-low 4 percent.

The voters do not think that the wage funds are especially vital either. Three percent say that the wage funds issue is vital, versus 6 percent in spring 1982.

It is above all the middle-class voters who believe that the wage funds issue is vital, especially the Moderates. Six percent of the Moderates see this as so, compared to 1 percent of the Social Democrats.

Alcohol and narcotics is another issue about which voter concern is declining. Five percent say that this is an important issue, compared to the record 16 percent in spring 1980.

#### One's Own Party

IMU has also examined how the voters' preferred parties--as shown in voter polls--are seen as handling the two most vital issues.

VPK voters are, as usual, most satisfied with their party's performance; the People's Party sympathizers are least satisfied.

Sixty-three percent of the VPK voters are satisfied, 56 percent of the Moderates, 47 percent of the Social Democrats, 39 percent of the Centrists and 30 percent of the People's Party voters.

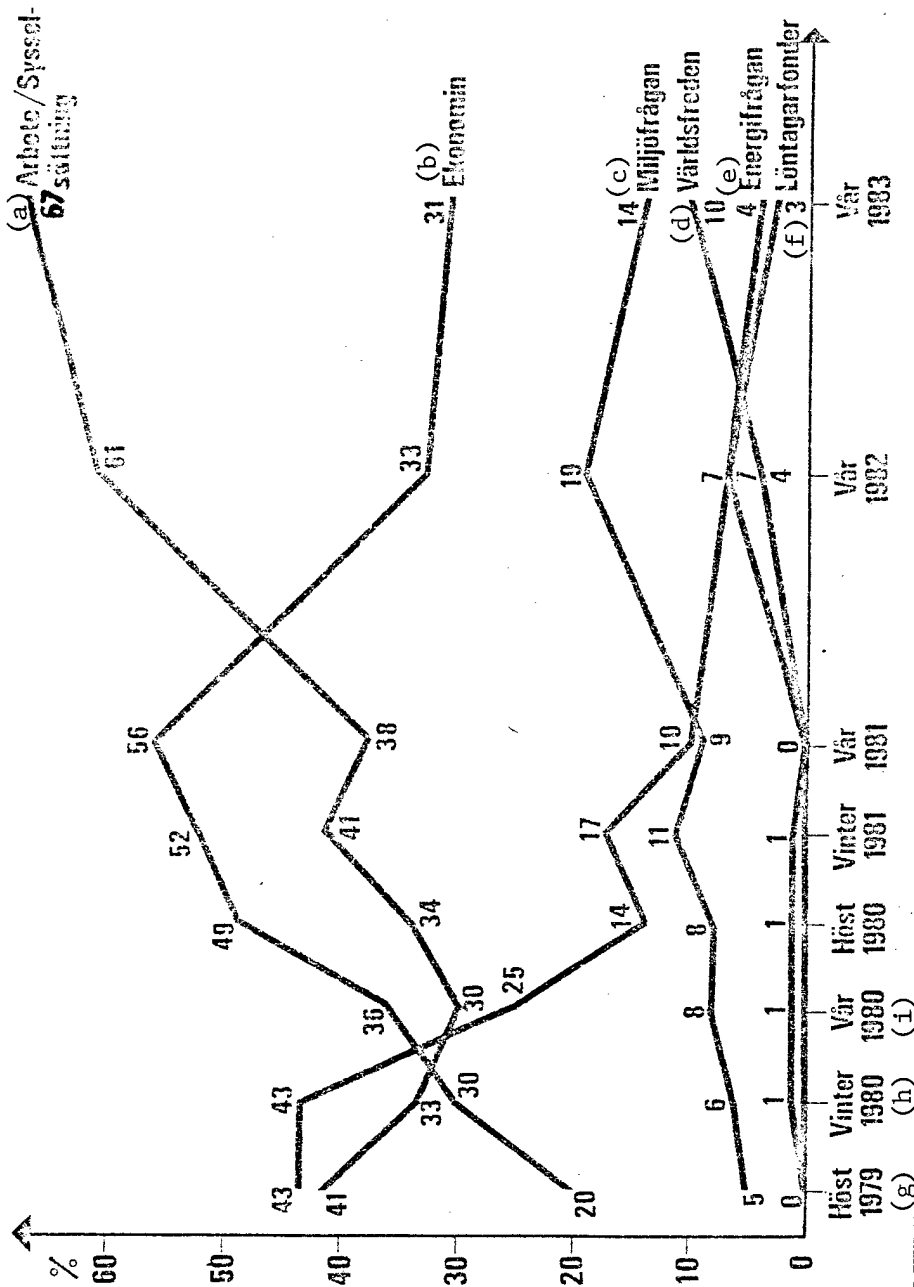

[Graph Caption] Employment and preserving world peace are the two leading political issues that are causing increased concern among the voters. The employment issue has increased from 61 percent in spring 1982 to the record 67 percent of this spring. World peace has increased during the same interval from 4 to 10 percent. The economy, environment, energy and wage funds, however, declined in the voters' perception of the two top-priority issues.

- Key: (a) Employment (g) Fall  
 (b) Economy (h) Winter  
 (c) Environment (i) Spring  
 (d) World Peace  
 (e) Energy  
 (f) Wage-Earner Fund

The "confidence figures" for the Social Democrats show a drop of 3 percent since spring 1982, probably due to the disappointments following the change of government. In the People's Party a drop is noted from 33 to 30 percent.

#### Managing the Best

The Social Democratic voters are most satisfied with their party's way of dealing with the wage funds (72 percent), the economy (60 percent) and employment (51 percent).

The Moderate voters are most satisfied with the struggle against the wage funds (76 percent), with defense policy (71 percent) and the economy (65 percent).

Fifty-seven percent of the People's Party followers are satisfied with the energy policy and 53 percent with child care.

Sixty percent of the Center Party Voters are satisfied with the energy policy and 58 percent with the opposition to wage funds.

Of the VPK voters, everyone approves the policy of care for the aged and the energy policy, while 82 percent support the party's energy policy.

9992

CSO: 3650/244

## INGA THORSSON TO LEAD COMMISSION ON DISARMAMENT

Stockholm DAGENS NYHETER in Swedish 15 Jul 83 p 7

[Text] Inga Thorsson, undersecretary at the Foreign Ministry, is to head the commission on disarmament and development established by the government on Thursday. The commission will, among other things, furnish examples of how military resources for peaceful purposes is one of Inga Thorsson's specialities. She was chair of a committee that worked up a UN study on the relationship between disarmament and development.

Inga Thorsson has then been one of Sweden's well-known names in the disarmament field for some time and she has chaired the disarmament delegation. But she has been on the sidelines for the past several years. This new appointment as chairperson restores some of her earlier territory to her.

The study that Inga Thorsson will head is a Swedish follow-up on a UN report on the same subject issued in the fall of 1981. The report shows, as do many other international studies, that the arms race costs an unreasonable amount in proportion to what the world actually needs.

Military expenditures are an excessively heavy economic expense for all countries and weigh on the economic future of all countries.

How defense resources can be reassigned to other uses in trends to disarmament and how the Swedish defense efforts appear in economic and social terms is the purpose of the study.

In addition, the study will show how Swedish development-aid cooperation with developing countries can be promoted by diverting defense resources to civilian use.

992

CSO: 3650/244

## PAPER VIEWS PROBLEMS OF POLITICAL PARTIES' YOUTH WINGS

Stockholm SVENSKA DAGBLADET in Swedish 15 Jul 83 p 7

[Article by Bosse Schon: "Political Organizaions No Longer Attracting Youth"]

[Text] Where have the young people gone?

That is the question being asked by political organizations after losing 39,000 of their members (19 percent) during the 3 years 1979 to 1981; nearly 1 out of 3 jumped ship.

The greatest slide occurred during 1981 (see the tabulations by organization).

The Centrist Youth Organization (CUF) decreased most during this 3-year period (20,000 members). Only the Christian Democratic Youth (KDU) showed an increase (500 members).

But after 1981, the Moderate Youth Organization (MUF) increased its membership in step with the successes of the Moderate Party.

MUF experienced a landslide loss in 1981 (2,721) and nearly recovered this loss in 1982 (up 2,300).

MUF is the only youth organization that reported new, updated membership figures to the National Youth Council.

This fall we will learn how the other youth organizations fared.

#### Recruiting Problems

One thing is clear: the political youth organizations are continuing to lose members. They are finding it difficult to recruit new members, and there is still a good way to go to reach the total 1979 membership of 200,000.

According to the latest count, the organizations had 165,697 members in 1982. The Christian organizations had over 270,000 members.

The largest groups of young people are found in sports organizations. No one ventures to say for certain how many of Sweden's young people are members of

a sports organization, but studies by the National Youth Council (the report "Not For Sale") shows that two-thirds of all boys in the 10-18 age group are members of a sports club, compared to one out of two girls.

Other studies show that the major problem of sports clubs is finding leaders for all who wish to participate, whereas the major problem of the political organizations is interesting young people in joining the organization.

#### Politics Is Hard

When the investigators asked why young people do not want to join political organizations, the answer was universally that politics is hard and has a generally negative image. Nevertheless, about 50 percent want to learn about politics.

The youth organizations remember 1968 when the political thermometer passed the boiling point and culminated in an unprecedented youth revolt.

No one is able to offer a satisfactory explanation for this lack of interest among young people in joining political organizations.

"They are tired of politicians!", "It's the fault of the youth organizations' programs.", "We're pursuing the wrong issues."--are some attempts to explain it.

#### Optimism

But despite the slumping membership statistics, the youth organizations are cautiously optimistic. The peace movement, as once did the Vietnam movement, is arousing the political interest of the young. Here, the youth organizations have the opportunity to recruit new members.

If not, and if the slide continues, "then democracy can suffer serious harm," believes CUF chairman Yngve Sunesson.

\* \* \* \*

"It's time to wake up now."

With this slogan, the Swedish Social Democratic Youth Organization is trying to recruit new members.

Youth are to be aroused to political understanding.

More than they do today, the youth organizations must show that they exist just for young people and that they are not miniparties, designed--like their respective mother parties--to deal with all possible matters, says organization chairman Jan Nygren.

"We have to show that we are organizations that stand up for young people and discuss the problems of the young."

## Profile

"A more distinct youth profile can attract more young people," Jan Nygren believes.

He cautions against overconcern with the statistics on membership trends in the youth organizations and against drawing abrupt conclusions about the political interest of the young.

"I am convinced that the average knowledge and commitment are greater today than ever before," say Nygren.

The problem of the youth organizations, according to Jan Nygren, is to absorb and channel this commitment into the political youth clubs.

"The problems of peace engage many young people, but this should not lead to publicity stunts of the kind we saw in front of the embassies. That was simply deplorable. We must seek to channel the commitment to peace into the youth organizations where it can be discussed in far better ways."

## Publicity Stunt

The "publicity stunt" to which Jan Nygren refers in the action that was in the news on 18 June when a group of peace activists, chanting and brandishing wheat sprouts, attempted to climb over the fences into the compounds of the American and Soviet embassies in Stockholm to sow wheat for peace.

Jan Nygren thinks that the problems of survival can spark the interests of the young in politics. At the same time, he sees that the problems of unemployment and lack of housing are overwhelming young people to such a degree that rather than working politically they are taking matters into their own hands.

"We are seeing a youth revolt that has nothing to do with 1968. Young people in Copenhagen and Berlin are occupying buildings not to demonstrate against the housing shortage, but just to have a place to live," explained Nygren.

9992

CSO: 3650/244

## PAPER CITES LACK OF BALANCE REGARDING EAST, WEST BY BODSTROM

Stockholm SVENSKA DAGBLADET in Swedish 5 Jul 83 p 2

[Editorial]

[Text] In an interview in last Sunday's DAGENS NYHETER, Foreign Minister Lennart Bodstrom described what he believes is Sweden's position on human rights. After stressing that Sweden makes no distinction between violations of human rights in the West and in the East, Bodstrom said: "Capital punishment, where a human life is taken, is the most serious violation of a human right. And this is followed by torture and unlawful deprivation of freedom. It is very hard for me to see any difference whether this is done in a state run by a parliament or in a state ruled by a single party. The violation of the private person is equally great."

The foreign minister thus defines violations of human rights solely on the basis of the physical sanctions that can be meted out to a person. He is indifferent to what criteria are used in various countries to apply sanctions. Such narrow and formalistic reasoning leads to a totally unacceptable concept of human rights and to a neglect of basic values of freedom.

Take the case of capital punishment for example. Even a resolute and unconditional opponent of capital punishment will find it hard to equate a legal system providing capital punishment for mass murder with a system applying capital punishment for criticism of the government. In questions of human rights, there is a gulf dividing such diverse systems.

Or consider Bodstrom's statement that illegal deprivation of freedom is equally to be condemned in a parliamentary state as in a one-party state. That is indeed true. But there is another dimension as well, one that Bodstrom's one-track way of thinking cannot accommodate. This is the fact that one-party states are by definition a denial of basic human rights in that they do not allow space for freedom of opinion or for political alternatives.

At the beginning of his term as foreign minister, Bodstrom gave birth to something called the Bodstrom doctrine, stating that a country's specific action should be judged, not its political system.

There were then discussions as to whether this was actually the laying down of a new doctrine or whether it was not rather a case of an unfortunate formulation by an inexperienced foreign minister.

Bodstrom's blunders can no longer be explained away in this kindly fashion. His recent statement signifies nothing other than a wider interpretation and sharpening of the old Bodstrom doctrine.

It is depressing to observe where this leads. The decisive differences in ideological, political and legal systems will be glossed over in a general anything-goes philosophy. In the obscurantism of Bodstrom, all governments are the same.

9992

CSO: 3650/244

## WAGE-EARNER FUNDS EXPECTED TO BE PREDOMINANT FALL ISSUE

Oslo AFTENPOSTEN in Norwegian 11 Aug 83 p 27

[Article by Morten Fyhn: "Swedes Arm Themselves for Bitter Struggle Over Wage-Earner Funds"]

[Text] Stockholm, 10 August. The stage is set for a hot political fall in Sweden because of the controversial wage-earner funds. Everything indicates that the Palme government, with the support of the communists, will get approval in the Riksdag for introducing the funds in 1984.

The Social Democrats call their funds a wonderful socialist experiment. But they also assert that Sweden is in no way moving toward a new economic system of the East European type, as their opponents claim. On the contrary it is emphasized that the funds will only have a limited importance, even if they will be a factor to be reckoned with.

Opponents--the three nonsocialist parties and business organizations--have warned that they will stop the funds by all legal means. The proposal is a direct declaration of war against Swedish business, and will lead to pure socialism, they say.

#### Dominant Place

Ever since the idea of a wage-earner fund appeared at the LO [Federation of Trade Unions] congress in 1971 it has taken a dominant place in the Swedish political debate. The funds were especially central in last year's election campaign, since both the party and LO had passed recent congress resolutions which they were going to introduce after an eventual leftwing victory. In the summer a final committee recommendation came to the table. The recommendation blew new life into the debate. It is now out for hearings.

During August-September the government considered inviting the political parties, labor market representatives and business organizations to conversations about the funds. In November the Riksdag expects to get the government's proposal, which in all probability will be approved before Christmas, thanks to the votes of the communists. Certainly the communists are unhappy

with the committee proposals because they reportedly do not go far enough in the socialist direction. But hardly anyone believes that the party will for that reason vote with the nonsocialists. In that case there would be a government crisis.

The three nonsocialist parties, Conservative, Center and Liberal Parties, have already clearly said that they are not interested in negotiating with the Social Democrats on the funds. "We will naturally not sit down and negotiate the introduction of socialism into Sweden," said former prime minister Thorbjorn Falldin recently.

Prime Minister Olof Palme says he is concerned over the campaign against the funds which the nonsocialists and business interests have mounted, and which they warn they will step up later in the fall. "Just the same I hope that they will come and reason with us. But if they refuse, we naturally can not give them the right of veto," he said.

#### Clear Front Lines

The front lines are thus drawn before the great political battle of the wage-earner funds. At the moment there is no sign of willingness to compromise from any of the antagonists. Their positions appear to be fixed, and are expected to remain so. The nonsocialists have stated that regardless of how relations between them might be, they will liquidate the funds after an eventual election victory in 1985.

The motives of the Social Democrats for bringing in the wage-earner funds are many. The only motive they do not say they have is the one which the opponents emphasize the most: transfer of private property rights to the labor union movement by means of the collective wage-earner funds. The official motives of the supporters are that the funds will strengthen the solidarity of wage policies, improve the influence of the wage-earners, equalize the bias in distribution of property, contribute to bringing in business capital and strengthen the existing people's pension system.

#### The Funds Proposal

The new funds proposal looks like this: Five wage-earner funds are established within the framework of the existing pension fund system, the so-called ATP system. The funds will own stock in business, but not themselves operate businesses. Each year the funds will pay in three percent of their income to the pension funds.

The wage-earner funds will get their money for buying stock in two ways: Partly from firms, banks, insurance companies, etc., which will pay in 20 percent of their surplus, and partly that they will also pay a fee of up to 0.5 percent of their total wages. A firm may, however, retain 500,000 kroner in tax free surplus.

## 400 Million Per Year

The committee calculates that each of the five funds will get up to 400 million kroner per year to buy stocks. According to the committee up to 1990 the funds will be able to buy stock in Swedish business for 14 billion kroner, calculated in fixed currency value; the plan does not go beyond 1990 for the time being.

For these billions the five funds together will own 7-8 percent of the stocks of the companies listed on the stock exchange. Supporters of the fund believe that is not so much that anyone can accuse them of socialization. They further claim that the five funds together will not be able to own more than a maximum of 49 percent of the stock in a company.

## Fund Management

The wage-earner funds will be set up in different places in Sweden. They will each be managed by nine persons, of which at least five will represent the labor union movement. The managers of the funds will be named by the government. On that point conflict has broken out within the labor movement, because both LO and the Social Democrats previously spoke directly of public election of the fund managers in order thereby to give the wage-earners a more direct influence over and attachment to the funds. Today it is only said that it is technically very complicated to conduct such elections. They say they will eventually come later.

## 'Enormous Power'

Opponents are furious about the whole funds idea, and are in no way calmed by assurances that the funds will not mean significant changes in today's system. In reality the five funds will have enormous power, say the opponents, 49 percent of the stock in a company is more than enough to have full control. In the largest Swedish industrial firms today the stocks are so spread that 10-15 percent is enough to give decisive influence. Marcus Wallenberg often had no more than 5-6 percent of the stock, but nonetheless in practice he had management control, it is alleged.

To the argument that the funds 7-8 percent of the total stock value is nothing to fuss about, the opponents say that in any case it is three times as much as the largest individual stockholder owns today.

9287

CSO: 3639/158

## BARLAS ON STATE'S LACK OF RESOLUTION IN FACING PROBLEMS

Istanbul MILLIYET in Turkish 10 Jul 83 p 1

[Editorial by Mehmet Barlas: "Irresolution"]

[Text] What all of Turkey's unsolved problems need is not money... When problems are approached seriously and with determination, many are able to be solved.

There are mountains around Hakkari where springs rise and become rivers. To the extent, in fact, that the head of a family which owned one of these mountains once thought about suing Iraq for compensation. He was going crazy thinking, "The water from my mountain flows into the Zab River and goes to Iraq. I must get paid for this water."

There is water everywhere around Hakkari. But in Hakkari, the fountains have water only 2 days a week.

Actually, this is not just a Southeastern problem.

When we returned to Istanbul, there was no water in our house, either. The tourist center of Bodrum is a ruin in the summer, because for years it has had no water.

The problem is to resolve upon a task, start it and finish it.

The state has been unable to bring water to Hakkari.

However, 800 Uygurlu refugees who came from Afghanistan and settled around Van have managed to spend 200 million on their settlement. This group of Afghan refugees in Van have a 4,000-lira salary for each man, a home for each family and free electricity and water for each home. Now they will have their own pastures and new homes in a more expansive land...

But the fight for fields and pastures on unregistered land will go on in the Southeast. Yes, there are still provinces in our country without a land registry. Because of this irresolution of the land, villagers get into quarrels that become blood feuds.

And the sectors that have been debating the vicious circle of land reform for years have been unable to get an emergency land registry campaign started.

Is it not the same in many matters?

We returned to Istanbul and took part in the seminar sponsored by the Foundation for Political and Social Research on "Turkish-German Cooperation." The topic at one session was Turkey's Common Market membership. Turkish panelists were criticizing Greece's membership in the Common Market.

Germans came to the podium and asked:

--Have you, meaning Turkey, arrived at a decision on this? Do you want to join the Common Market? If you are going to join, why do you always put off your application for membership?

Most likely, our social logic militates towards delay. This is true for every problem.

Then, we get mad and rail at the inadequacy of resources, or the Germans, or nature.

8349

CSO: 3554/370

## TURKISH LABOR PARTY TRIAL CONTINUES IN ISTANBUL

Istanbul CUMHURİYET in Turkish 2 Aug 83 pp 1,11

[Text] The defense began presenting its arguments in the TIP [Turkish Labor Party] trial that is being held at the 2d Military Court of the Istanbul Martial Law Command.

In the last hearing, the military prosecutor, after presenting his views on principles, asked for the acquittal of the five of the 144 defendants in the TIP case. The prosecutor also demanded hard labor prison sentences of 8 to 15 years for 17 defendants and 5 to 12 years for 118 defendants. The military prosecutor further demanded that the files of four of the defendants be separated from the rest.

In a 25-page defense statement read at yesterday's hearing, TIP Central Administrative Council member Alp Selek charged that the court has no jurisdiction over this case. Selek said: "The prosecutor's office has acted in contravention of the Constitution, the Political Parties Law and Turkish and universal juridicial principles by opening this case, pursuing it and expressing opinion on principles."

Selek said that the indictment and the opinion on principles focused on TIP's bylaws, program and activities and that, however, neither he nor the other defendants were asked whether they took part in the party's decision making process and activities. Selek continued:

"The charges have been based solely on the party's bylaws, program and resolutions as well as certain magazines, books, pictures and articles that were allegedly in the possession of the party. The manner in which the charges have been brought and the trial is being conducted violates the principle of personalization of crime and clearly proves that it is the party as a corporate body that is being tried here and not our persons."

Stating that only the Constitutional Court is authorized to try a party as a corporate body, Selek claimed that this court can only try him for activities that are outside party bylaws, program and congress resolutions. Selek said: "As can be seen from the file, the indictment, which was prepared illegally and without proper authorization, contains no charges against me outside baseless allegations without evidence."

In his written defense statement, Selek stated that the party's bylaws, program and resolutions were legal and added:

"Today, we are still affected by the conditioning of the emergency situation. However, you are individuals who are in a position to make decisions. The verdict you will pass will have an important role not only for today, but also for the democracy of tomorrow and the establishment of a modern Turkey and a government of the law in the future.

"Consequently, I expect and hope that you will pass a verdict which will surpass the conditioning imposed by the circumstances of the day and which will conform with the imperatives of the supremacy of the law, the continuity of the state and a government of the law."

After Selek's written defense statement was read, defendants Dincer Dogu, Yavuz Unal, Cetin Gozacti, Vedat Baranoglu, Bekir Yenigun, Gunduz Mutluay, Nermin Aksin, Ibrahim Sonmez and Husamettin Bakan presented a 50-page defense statement.

The joint defense statement read by Dincer Dogu said that as party administrators and members the defendants were defending the economic, democratic and political rights and freedoms of the working people.

Stating that only the Constitutional Court is authorized to try TIP, Dogu said that this is a political trial. Pointing out that the military prosecutor has declared as illegal a political party that has been active for nearly 6 years, Dogu said: "To claim that the defendants must be tried in a martial law court outside the Constitutional Court is to risk eliminating the concept of the government of law one more time."

9588  
CSO: 3554/397

## GOZE GIVES WARY EYE TO SOCIAL DEMOCRAT PARTY

Istanbul TERCUMAN in Turkish 9 Jun 83 p 11

[Article by Ergun Goze]

[Text] The abbreviation for the newly formed party is SODEP [Social Democrat Party]. Why is it SODEP and not SDP? Why is there such a strong desire to use the first syllable of the Turkish words, socialism [sosyalizm] and leftism [solculuk]? Who thought up this "neologism"? Newspapermen? Party members? Let's not go into this. This columnist has been acquainted with the new leader of the new party, Inonu, since 1971. I remember the titles of the articles I wrote about the role he played in those days -- "The Young University President," "The President at the Bottom of the Sea," "Where is Erdal Inonu?"

I looked at the articles I wrote while he was president of METU [Middle East Technical University] years later. I noted that Inonu got along very agreeably with social democrat organizations at METU during the course of his presidency.

And now they come from the social democrat organizations to honor by visiting the leader of the Social Democrat Party. Congratulations! From such bad beginnings, a bad ending is inevitable. There are some founders who cause one to think seriously -- from the standpoint of the future of the law, regulations, and the people, in behalf of the system of government. One of these is TBB [Turkish Bar Association] Chairman General Atila Sav. A formidable jurist, he is presently chairman general of the TBB. He was selected, at the same time, to be the deputy chairman general of the newly formed party.

You will understand that Sav is chairman general of the TBB and deputy chairman general of SODEP as well. I think that this is the first time in history that this has been accomplished. And this took place despite the law. Under Article 3 of the Attorney Law, the TBB cannot engage in politics. Of course, since Sav is such a formidable jurist, the legal personality of the TBB does not engage in politics. He is able to say, "As for me, I engage in politics in my own name." No one can be surprised by the "humorous sincerity" in this statement, because he knows of his political adventures since 12 March.

The decision-making organs and members of the TBB have preferred to remain spectators in this situation. They are still observing what has taken place. However, the problem is very serious. If a new era is being launched, it is necessary for us to be wiped clean of as much of the dirt and dust of the past

era as possible -- particularly from the standpoint of the political staffs and, from among those, those who have engaged in politics primarily on non-political staffs. It is imperative that we indelibly engrave in our minds what 12 September is.

The 11 September is the reverse of 12 September. This must not be forgotten.

On 11 September, it was the custom to oppose the state security courts. A number of jurists and even the bar and the bar association as well came out against the courts. The 1982 Constitution, however, settled this argument once and for all and considered the state security courts a necessity of the system of government.

On 11 September, it was fashionable to call for the elimination of Articles 141 and 142.

Following 12 September, this, too, went out of style. Measures to check communism and fascism were introduced to a greater degree in the constitution and all other laws as well.

It was the custom to admire Nazim Hikmet. Now, the use of this as a cover for a citizen's treachery has clearly come to light.

It was the custom to be an advocate of 1 May. Now, the 1 May holiday has been eliminated, and the 29 May victory anniversary is celebrated with more excitement.

It had become fashionable to be an enemy of NATO and to even applaud the Russian army that invaded Afghanistan. Now, all this is changed. We wonder, for example, if some of SODEP's founders -- and Sav in particular -- have also changed the thoughts they had at one time.

There is a point, however, that pacifies the people. Because the National Security Council does not wish to cause this nation to return to the days prior to 12 September, it takes meticulous measures necessary so as not to do so. The decision reached regarding the MDP's [National Democrat Party] changing three founders within 5 days demonstrates this. It can be seen that the principles set down by the National Security Council are being applied to everyone in a sensitive and objective manner.

(Note: This article was written before the seven founders from both the People's Party and the Motherland Party were vetoed.)

11673  
CSO: 3554/321

## PARTIES RACE TO ORGANIZE ON PROVINCIAL LEVEL

Istanbul TERCUMAN in Turkish 10 Jul 83 pp 1, 11

[Text] Ankara (TERCUMAN) -- The political parties have 45 days left in which to fulfill the 34-province barrier rule for running in the 6 November elections.

Of the 11 political parties formed to date, only the MDP [Nationalist Democracy Party] has exceeded the barrier, having organizations in 41 provinces.

The Fatherland Party has set up organizations in 29 provinces in the 47 days since it was founded, coming close to the 34-province barrier. Party authorities report that the Fatherland Party will cross the barrier tomorrow and raise its number of provinces to 47 before the holidays.

The Populist Party has managed to set up organizations in only five provinces so far. SODEP [Social Democrat Party] announced 8 more provinces yesterday to raise its number to 11.

The new Birth Party, the New Order Party, the Virtue Party, the Right Way Party and the Republican Conservative Party have not yet taken the plunge in provincial organizing. Meanwhile, "Our Party," formed day before yesterday, was the latest to join the long line of political parties.

## Which Parties, Which Provinces

MDP: Mugla, Kastamonu, Adana, Mus, Bilecik, Van, Hakkari, Sivas, Hatay, Izmir, Ankara, Giresun, Gaziantep, Bingol, Istanbul, Siirt, Urfa, Kahramanmaras, Diyarbakir, Burdur, Amasya, Agri, Mardin, Canakkale, Erzurum, Kars, Sinop, Yozgat, Cankiri, Bursa, Trabzon, Rize, Gumushane, Ordu, Tokat, Malatya, Nigde, Corum, Konya, Bolu, Eskisehir, Edirne.

Fatherland Party: Istanbul, Izmir, Yozgat, Antalya, Burdur, Afyon, Konya, Sakarya, Erzurum, Kirklareli, Edirne, Tekirdag, Gaziantep, Zonguldak, Elazig, Malatya, Mardin, Mus, Adana, Icel, Bilecik, Kahramanmaras, Giresun, Hatay, Ordu, Bingol, Kayseri, Erzincan, Ankara.

Populist Party: Ankara, Agri, Hakkari, Samsun, Malatya.

SODEP: Eskisehir, Konya, Kayseri.

As known, political parties must have organizations in at least 34 provinces by the night of 24 August in order to run in the next elections. The Supreme Electoral Council will request a list of the parties with organizations in 34 provinces from the Ministry of the Interior on 25 August. The Council will announce the parties that have won the right to run in the 6 November elections on the basis of the official data provided by the Ministry of the Interior.

Meanwhile, civil servants wishing to run in the next general elections must leave their jobs within 15 days. Civil servants who have not resigned from their jobs by 25 July will not be able to run for national deputy.

8349

CSO: 3554/370

## MDP'S SUNALP PROMOTES PARTY, DISCUSSES IDEOLOGY

Istanbul CUMHURIYET in Turkish 3 Aug 83 pp 1,11

[Text] Corum/Samsun--Turgut Sunalp, the leader of the Nationalist Democracy Party [MDP], said that his party is "the plaintiff of yesterday and the safeguard of tomorrow", that they "have planned every measure to make Turkey a modern country" and that "when our noble nation hands over the reins of government to the MDP with its auspicious votes on 6 November, it will find people who know what to do and how to do it." Sunalp said: "We are a party which promises realistic measures and not a rosy picture of everything."

The MDP leader began to tour the Eastern Black Sea region together with his spouse, Suzan Sunalp, deputy MDP leader Davut Akca, MDP Secretary General Dogan Kasaroglu, Deputy Secretary General Yilmaz Hocaoglu and General Treasurer Macit Zeren. Sunalp opened the MDP provincial organization in Corum yesterday morning and in Samsun in the afternoon.

Speaking during the opening of his party's provincial organizations, Sunalp recalled his words during the opening of MDP's Ankara provincial organization and said: "I stated that I would start opening the package of services we will offer our nation on 6 November. Today, I start doing my duty in your presence. Our first service commitment will be to maintain the citizens' freedom to live without fear. I declare in your presence that the MDP will safeguard the environment of peace and security that has been established in our country."

Stating that they "know where the conspiracies plotted against Turkey originate from", Sunalp said that his party "is in the best position to assess the true character and goals of communist ideology which is the enemy of the integrity of the state and the nation." Sunalp continued: "I have personally studied and observed communist ideology and culture for years." The MDP leader added that "other valuable colleagues sharing the same views" are also working with the MDP and that, as a result, they know how to fight against communism.

9588

CSO: 3554/397

## BIRAND ON DREARY STATE OF FRANCO-TURKISH RELATIONS

Istanbul MILLIYET in Turkish 9 Jun 83 p 7

[Article by M. Ali Birand]

[Text] There is probably no way to talk about Franco-Turkish relations any longer, because not much of a relationship remains between the two nations in the diplomatic sense.

How could one remain when...

The Turkish ambassador in Paris has been living as if under an embargo for a long period of time. He is only able to speak with Ministry of Foreign Affairs' officials at a certain level.

How could one remain when....

The French Government takes a position opposing Ankara on every subject that is of close interest to Turkey. One country may not agree with another because of specific ideological and general political reasons, for reasons of political differences. However, we are able to claim that there is not a single significant issue about which France is in agreement with Turkey. If you consider keeping the Mediterranean coast clean a political issue, then that, of course, is something else....And what is more important than this is that France maintains these policies as if to challenge Turkey rather than to abuse Ankara excessively, rather than to bring Ankara to the point of breaking off relations.

Not a day goes by that the respected French Minister of Foreign Affairs Cheysson does not make a statement that misuses Turkey. Not a day goes by that a decision made by France does not agitate Turkey.

No one can assert that the policy applied by Giscard d'Estaing sided with Turkey. He was a person who openly supported Greece, who felt sympathy for the Armenians, who stated that he could not close his eyes to the Armenian cause. However, the big difference between him and the Mitterand team is that d'Estaing did not give permission for the state television organization to be put into a position of becoming the official broadcasting body of Armenian terrorist organizations and that d'Estaing knew to pursue policies that did not discomfit Ankara more than necessary, even if his policies did not garner sympathy for Turkey.

The questions for which the Turkish circles that closely follow this gradually increasing tension in Franco-Turkish relations cannot find answers, yet which are of great interest are:

"What is France's purpose? Is there a reason for this position? If there is, at which political foundation does it rest?"

No one is able to diagnose exactly the reasons for France's antipathetic approach toward Turkey or the logic behind this approach. Reasons based on speculation that does not go beyond theory are being mentioned.

1. The number of persons is not small who claim that such actions are being carried out within the labor branch framework that exists in western Europe, out of the tradition to be Greece's spokesman, to be protector of minorities such as the Armenians, and, finally, as a socialist government, out of the necessity to criticize the form of government in Turkey.

2. Another portion asserts that France is acting in this manner because of its Middle-East policy and that its long-term policy includes the breakup of Turkey and the establishment of a new state in Anatolia.

It is very difficult to believe that a large nation such as France could blindly pursue an unproductive policy as defined in both these possibilities.

How is it possible for a France that, on one hand, understands the role of Turkey in the defense of the West and that places more significance on this than it demonstrates in its public statements and that, on another hand, is intelligent enough not to wish a nation of 9 million people to lose another ally with 50 million people and, finally, that knows how difficult it would be to split apart Turkish land to follow an approach such as today's that does not fit into any logic whatsoever?

As we said previously, the chief reason for Paris' approach that comes to mind if we look upon the subject with, perhaps, too much benevolence is that the Champs Elysees has not found a true "Turkish policy."

The point reached in relations with Turkey is not known precisely by anyone, whether it be the French press or the administrative powers in the broad sense of the term. When you speak with anyone, you receive the reply, "Yes, what you say is probably correct. Our relations with Turkey are probably not very good."

This lack of consciousness on one hand and Turkey's persistence in maintaining a passive position on the other are dragging these relations directly to a dangerous spot such that we will find, one day, that the remnants of these relations have reached the state where they cannot be put in order again.

Then, of course, it will be too late.

11673  
CSO: 3554/321

## NORWAY, SWEDEN TO SIGN ARMS PURCHASE PACT

Stockholm DAGENS NYHETER in Swedish 11 Aug 83 p 13

[Article by Bjorn Lindahl]

[Text] Oslo, Wednesday--The big Swedish-Norwegian arms agreement that may result in 5 billion kronor worth of orders for Swedish firms is now ready at the permanent-representative level. The Swedish Armed Forces still want to check some of the legal wording, but it is expected that the agreement will be signed at the start of September.

The arms agreement does not mention any specific purchases, but it provides the basis on which purchases can take place. During the preliminary negotiations, however, there was a discussion of individual projects and of an overall monetary framework for the purchases that will be made over a 15-year period.

Norway is facing major defense investments because a great deal of the materiel it now has was obtained under U.S. aid programs and needs to be replaced.

For Sweden's part, this may mean a sum of 5 billion kronor over a 10-year period, while Norway wants to make sure through this agreement that Sweden will buy an equal amount of high-technology goods from Norway in exchange.

#### Tracked Vehicles

Swedish products that the Norwegian Armed Forces are interested in include tracked vehicles from Hagglund and Sons. The Norwegians have already bought some of those vehicles, and they are very pleased with them. They may decide to buy more of them at a cost of several hundred million kronor.

A weak spot in Norwegian defense is protection of its airports. Norway has decided to buy batteries of U.S. Hawk missiles, but Ericsson is in the picture as a possible supplier of radar systems for those missiles. A contract would be worth about 200 million kronor. The Norwegians also want to modernize their Swedish antiaircraft guns produced by Bofors--the so-called L-70 guns--with new radar sights, and this will also come to about 200 million kronor.

## Engine Components

For its part, Sweden may consider buying some engine components and the navigation system for the JAS project from the Kongsberg Arms Factory [KV]. Contacts between the KV and Saab-Scania have already been made. Other Norwegian firms are the Raufoss Ammunition Factories, the Electric Bureau, the STK [expansion unknown], Simrad, and the AME [expansion unknown].

Bernhard J. Eggesbo, permanent under secretary of state in the Norwegian Ministry of Defense, explains: "That amount of 5 billion kroner in reciprocal purchases depends, however, on the assumption that the firms in both countries will be competitive internationally and that the respective defense ministries will not have their budgets cut."

Negotiations concerning specific projects may begin immediately after the agreement is signed.

11798

CSO: 3650/269

## AIR FORCE CHIEF REPLIES TO CHARGE OF DEFENSE SHORTCOMINGS

Copenhagen BERLINGSKE TIDENDE in Danish 4 Aug 83 p 7

[Article by Johannes Skjoth, Major General in the Danish Air Force]

[Text] After returning from a 4-week vacation abroad, I see that the debate over our defense preparedness and efficiency--or rather the lack thereof--which was initiated by Col C. F. Hagen has been rounded out by an article by Defense Minister Hans Engell, published on 30 July.

I hope there is room for a few words from the air force, the youngest branch of our defense system.

After a day of intensely studying the many articles in BERLINGSKE TIDENDE, I feel it necessary to point out that the army is not the only component of Denmark's defense. As a result, if Col C. F. Hagen believes that the army lacks morale, strength, and credibility, this does not necessarily apply to the other branches of the military--the air force, for example. I have served in the air force for over 31 year. The strength and the effectiveness of the air force has increased each of these 31 years. Today, the primary fighting units of the air force--the fighter squadrons and the air defense missile squadrons--possess greater strength than ever before in the history of the air force. Even though our potential opponent is 5 to 6 times as strong and we are always in an inferior position, this does not make us cripples or dwarves.

The state of preparedness of the air force also is acceptable. All the warning and monitoring units of the air force work around the clock and all fighting units can be ready for battle within a short period--hours rather than days.

We in the air force cannot be sure that we will be capable of fighting long enough for our allies to provide reinforcements. For this reason, we ask for more air defense in Denmark in the form of more fighters and more missiles. This is not for the sake of the air force, but to protect the army's mobilization, naval operations, the civilian population, and the advance of allied reinforcements.

But we in the air force are capable of fighting.

On 23 July 1983, Col C. F. Hagen addressed several questions to politicians who are friendly to the military. I believe the following question was the most important:

"How long will you be satisfied with operating the military under peace-time conditions that greatly affect the discipline, morale, and training needed in case of war?"

This question should not be directed toward the politicians. Col C. F. Hagen also should write about the "army" and not the "military." Finally, I refuse to believe that Colonel Hagen has grounds for his assertions. In any case, they do not apply to the air force. I know that air force personnel have the training, morale, and discipline required in a life-and-death battle and needed to endure difficult wartime conditions. I also believe that personnel in the other branches of the military possess this strength. If not, this is hardly the fault of the politicians, but rather of this personnel's superiors.

9336  
CSO: 3613/170

## RETIRED CAPTAIN SAYS DEBATE ON DEFENSE SHOULD BE BROADER

Copenhagen BERLINGSKE TIDENDE in Danish 4 Aug 83 p 7

[Article by F. F. Bork]

[Text] The defense minister and Col C. F. Hagen have conducted a debate in this newspaper over our defense, although their positions are virtually identical:

1. General considerations concerning the defense of Denmark.
2. What can be done here and now.

Let us first examine problem 1. The following aspects are involved:

The balance between a professional elite and the "common soldier," between standing forces and forces that can be mobilized, and between preparedness and training;

Economy in the military, in the sense that the military must not cost more than "necessary." Thus, there is a correlation between these two personnel groups or, in other words, a compromise between "one man, one gun" and a submarine equipped with nuclear weapons in the Atlantic Ocean;

The best possible utilization of our country's total military potential, so that the country cannot be crippled by destruction (or the threat thereof) of several nonmilitary facilities (for example a power plant, water works, a certain portion of a city, or a large bridge).

There must always be a middle path between these aspects. If every effort is made to solve individual problems, any chance of solving the overall problems will be lost.

But it is good to have this debate before any definite decisions are made in the defense compromise. But for now, let us forget these broad questions. Let us examine current conditions and simply ask: "Are we getting our money's worth?"

It is easier to examine the problem in this way, although it ignores the overall picture. Despite this, I would like to point out certain areas in which money should be saved and others in which more should be spent. Most expenditures are personnel-oriented, so that most savings must be made here. Savings could be realized in the following ways:

By eliminating "civilian" functions (for example, fisheries inspection) from the military;

By increasing the efficiency of troop training within the army;

By changing the regulations so that jobs are less rigidly linked to rank;

By better planning of training and maneuvers to reduce the amount paid in bonuses.

More must be spent in the following areas:

Better materiel for mobilized units;

More PR for the military;

Cooperation within the framework of the total defense;

More frequent exercises by mobilized units.

The following action could be taken with no effect on costs:

More should be done to utilize the civilian training of recruits (I know, for example, that certificates of apprenticeship are taken into account, but other training at lower levels also should be considered);

Individual assignments within NATO should be more clearly defined so that, for example, West German naval units would take over "Danish" patrol assignments in the Baltic Sea;

NATO facilities should be improved (depots, etc.).

I repeat, however, that this simply is an attempt to patch up the existing structure and not an attempt to describe the responsibilities of the military in general.

In addition, the proposed cutbacks could be justly criticized. The time may not be right for them all, but they should be considered as part of the drive toward efficiency if they also help pave the way for much-needed modernization (which will require more expenditures).

## COLONEL CHARGES POLITICAL LEADERS WITH IGNORING MILITARY

Copenhagen BERLINGSKE TIDENDE in Danish 23 Jul 83 p 7

[Text] Colonel C. F. Hagen, who through a feature article in BERLINGSKE initiated a lively debate on Danish defense, concludes the debate in this article with a number of questions directed to all politicians who favor military defense. It worries him deeply that he has been able to contest all official statements about the credibility of Denmark's military defense and he does not mean to be sarcastic when he writes that today's 8 to 4 peace army rests on the supposition that the Warsaw Pact will prevent an attack outside the regular business hours.

My articles on defense have elicited a number of commentaries, some of which support and complement my points of view while others are very critical.

Actually, the criticism has come exclusively from representatives on the various levels of the policemen's union. That is somewhat surprising. The careful reader of my feature article would find that top-level military leaders as well as the group to which I belong have a greater right to feel stepped on and thus react. But that has not happened.

A detailed refutation of the criticism would take an unreasonable amount of newspaper space; there are just too many unfounded postulates and misrepresentations of what I actually wrote. Some of them have been refuted in earlier articles and some must be left to the reader's judgement. Especially to prevent misunderstandings on the part of the public, I wish to point out certain things and then bring the discussion back to the main theme.

First; I must point out that the representatives in question--regardless of what they themselves think--do not have any military expertise in the area debated. You cannot acquire that by simply completing basic military training. Their stated agreement with the Minister and the Supreme Commander carries no more weight than that of a random citizen. The very same thing applies to their opinions concerning the army's organization and equipment.

The lack of expertise is reflected in the statement that a soldier does not have to continue military training once he reaches the professional level. It should be obvious that professionalism does not maintain itself and that unit training and developing toughness in the field are still necessary.

The same applies to the statement about "a 7,500 strong and well-trained police force." Scattered throughout the country, 7,500 men do not go very far, at least not in countering a surprise attack. And it should have become evident that the army is not well trained either.

Mildly stated--it expresses monumental ignorance to use current personnel lists as proof that there are too many officers in the army. They do not in any way show the actual need, but an economically dictated and recently effected reduction in standards, which were already inadequate.

But--as I said earlier--except for the biased presentation, I agree that the shortages tend to be among the rank and file.

With respect to unilateral training, however, it is true that good results can be obtained in 3 to 9 months (and less) if everybody in the unit has the same basic education and if, indeed, laws and decisions that influence education, discipline and morale were made with the requirements of war in mind. That they were not and that is what we fail to discuss.

We can only meet the demands by further lowering our military preparedness, which we did once by bringing in policemen, for example. Prior to that time, we had a protective army consisting of about 13,000 men, 10 to 15 percent of whom always stayed in the barracks. In other words, real preparedness. After the system was put into effect, the barracks-type military preparedness proved to be too expensive because the policemen wanted extra pay. Today, our 8 to 4 peace army rests on the supposition that the Warsaw Pact will prevent an attack outside the regular business hours.

The only justifiable security measure would be to appropriate funds here and now to fill our standing units and to reestablish our military preparedness. If that is not possible, it would be logical to objectively reevaluate the police arrangement.

Of course, military discipline and morale are sensitive subjects in a democratic society. Discipline is primarily based on the exercise of authority and obedience, morale primarily on the individual's acceptance that getting the job done must come ahead of self. That clearly contrasts with the civilian sector, which cannot be overlooked.

For many years now, extensive and justifiable efforts have been made to lessen the gulf between civilian and military life. Unfortunately, the main purpose is often forgotten: the military's war-time effectiveness and thus its credibility.

One example is the development of the official cooperative hierarchy, which includes representatives on all levels who have been elected to defend their

respective groups' special political interests. The political structure lends itself well to that. For precisely the same reason, it cannot possibly lend itself well to the development of moral factors, which are crucial to the solidarity and the inner strength needed in war, where the job must come ahead of the individual. The representatives who have participated in this debate hold central positions in the hierarchy. The quality and objectivity of their statements say a great deal about the cooperative conditions in the present structure. Thus the Supreme Commander's responsibility, which they are fond to point out when it suits their purposes, will be disputed within narrow limits, purely directed toward peace.

Positive cooperation, which would benefit effectiveness as well as the individual, is possible even on the lowest level of government. However, I doubt that a superstructure consisting of a centralized political hierarchy would substantially benefit anybody else than those inside it. By getting rid of it, we may avoid the unnecessary use of time and money as well as what a contributor aptly called the poverty mole. We may yet jointly arrive at the realization that we are all employed by society to serve the national security, not to be supported in a secure and comfortable manner.

The standing army is supposed to take care of a surprise attack (which it cannot do at this time). But we should not overlook the army's main body which consists of mobilized conscripts principally commanded by reserve officers. It is indispensable, both as a necessary supplement and because it serves as a link between the people and the military.

We do give our young conscripts some training, the absolute minimum for combat troops. Savings measures have resulted in fewer reviews which would otherwise give enlisted men and their leaders a needed chance to supplement their training and to develop solidarity, which is vitally necessary in the event of combat. Modern effective equipment is to a great extent lacking, although it is very important to units that must be thrown into combat upon mobilization. In the event of mobilization, we would find that we cannot even fully equip the individual soldier. I find that irresponsible and immoral.

And it is not just a question of changing our priorities with respect to the use of allotted funds. That would only widen the gaps elsewhere.

Several contributors have pointed out similar conditions in and outside the army and they have not been given any answers.

When we in peacetime more and more dismiss from our consciousness the purpose of our military defense and when we apportion an ever declining share of the national budget to fulfillment of that purpose, the predictable result is a fight for existence. And--the important thing--the chance to avoid it becomes correspondingly less. The lower the credibility, the greater the risk. Our membership in NATO is losing its meaning because we make it impossible for NATO to come to our aid.

We have been traveling this road for 10 to 15 years now, during periods of national abundance as well. It should, no doubt, provide food for thought and deep concern that my statement about credibility--which clearly contests official statements in every respect--remains unchallenged.

If we want to reestablish our lost credibility, it will cost us both money and effort. There are no cheap solutions. No one can blame the people for being reluctant to spend more tax money of defense based on false information. We cannot predict what would be the reaction to correct information, but our membership in NATO, the massive support of the home guard and our conscripts' attitude toward and in service suggest that we perhaps underestimate a latent defense spirit. It gets less attention in the monopolitic mass media than do the peace movements, but might indeed be more representative of the people's attitude.

I must direct a few questions to politicians who favor military defense and who are fortunately so plentiful in all the important parties:

How long can you live with the fact that our military defense is premised on peace, which substantially affects the discipline, morale and training needed for war?

How long can you accept a military preparedness which makes it possible for Warsaw-Pact troops to enter our country early tomorrow morning without any opposition to speak of?

How long can you accept the fact that both the standing army and the mobilized forces can be thrown into combat for which they lack mental preparedness as well as the necessary training and equipment?

In short, how long can you, through passiveness or for domestic political reasons, take responsibility for an untrustworthy military defense that costs 10 billion kroner when you can have a trustworthy one for 12 to 13 billion?

This is a matter of national security and survival.

The people do not need soothing explanations but facts, which I have tried to deliver. Who should be more likely to follow up on them than our elected representatives?

8952  
CSO: 3613/158

## BRIEFS

F-16 MODERNIZATION CONTRACT LOST TO BELGIUM--The Aircraft Materiel Command of Denmark has lost a major order. The order involves the modernization of 140 American F-16 planes. Bids were accepted for the contract, but the Danish offer was considerably higher than the Belgian bid of just under 250,000 kroner per plane. The modernization project could have provided work for several hundred employees at Alborg for 1 to 2 years. Major Gen Johannes Skjoth categorically denied that the Belgians received the order because of Denmark's critical attitude toward American plans to deploy nuclear missiles in Western Europe. [Text] [Copenhagen BERLINGSKE TIDENDE in Danish 4 Aug 83 p 2] 9336

DEFENSE COMMAND UNDERGOING REORGANIZATION--It now appears that the long-discussed reorganization of the Defense Command in Vedbaek, the supreme administrative leadership of the military, will become reality. The reorganization was discussed yesterday at a meeting between Defense Minister Hans Engell and the Defense Council, which consists of the top military officers. A reorganization would help in the planning and management of resources and would save personnel. [Text] [Copenhagen BERLINGSKE TIDENDE in Danish 5 Aug 83 p 2] 9336

CSO: 3613/170

## BRIEFS

MATRA EXPANDS SIGNES PLANT--The Matra group (military division) is going to proceed with an extension of its Signes facilities with the construction of a new plant for the cleaning-pickling of metal parts used in mechanical and pyrotechnical assemblies, put together in its factory. [Text] [Paris L'USINE NOUVELLE in French 16 Jun 83 p 51] 12415

AERONAUTICS SUBCONTRACTORS LOSE BUSINESS--Two factories working for the aeronautical industry have been occupied by their personnel, at Potez Aviation in Aire-sur-l'Adour (Landes) since Monday and at Micro-Mecanique in Gurmencou (Pyr-Atl) for the past week, in a protest against reductions in work schedules and lay-offs. In other aeronautical subcontracting companies in the southwest of France the situation is not much better. The Chamber of Metallurgical Industries of Atlantic-Pyrenees and Bordering Regions has stated since May that "the small and medium-sized companies subcontracting to the aeronautical sector are in danger, if not to say fighting for survival." In effect, airplane builders have maintained their capacity workload by manufacturing what had heretofore been subcontracted. The principal employers of the area are Turbomeca (4,203 employees) with plants in Tarnos (Landes) and Bordes (Pyr-Atl), Dassault-Breguet (1,909 wage earners) in Bayonne, Messier-Hispano-Bugatti (945 employees) in Bidos and Arudy (Pyr-Atl). Around them are clustered the small- and medium-sized companies embracing 2,600 people half of whom work for the aeronautical industry. [Text] [Paris LES ECHOS in French 16 Jun 83 p 10] 12415

CSO: 3519/551

## DEFENSE CHIEF: MAY REDUCE OPERATIONS DUE TO LACK OF FUNDS

Oslo AFTENPOSTEN in Norwegian 3 Aug 83 p 4

[Article by Ragnvald Naero]

[Text] Economic problems are now affecting the armed forces too. In order to get the operating budget down to manageable proportions, it is necessary to save between 110 and 120 million kroner in the current year. The situation is further complicated because the Defense Ministry, in contrast to previous years, has indicated that no extra appropriations will be granted this fall. "Unless we can get control over the causes of the economic problems, the nation's readiness will be gradually weakened in the course of a few years," said Defense Chief Sven Hauge.

General Hauge stressed to AFTENPOSTEN that he did not want to complain about what appears to be deteriorating conditions for the armed forces. "I want more help from my own personnel and from the politicians in getting operating expenses under control and investments up. We have been working on this for quite a while, but in the current situation it is more important than ever," Hauge said.

There are several reasons why the defense system is running into problems now. The year began with an activity level at the upper limit of what they really could afford. Costs were around 100 million kroner more than the amount budgeted, but the defense system was counting on saving that amount of money in the course of the year. But what should have produced savings have turned out to be producers of deficits.

Among other things, the armed forces called up more draftees than the quota indicates. This is due to a lower than anticipated attrition rate.

"In addition our personnel level is too high. A reduction here of both officers and civilian employees is necessary, even though everyone is complaining about a shortage of personnel," said Hauge.

He said that the details have not yet been worked out concerning the cut-backs that will be needed in the fall. The navy is the only branch of

the armed forces that has presented concrete measures that include among other things mothballing one of our frigates and calling up fewer draftees for basic training.

"The navy must save around 40 million kroner in the current year. The army must reduce its expenses by the same amount and the air force must make savings of over 30 million kroner," Hauge disclosed.

"This means that we must draw on our stockpiles, especially our fuel reserves. We hope to avoid drawing on the mobilization stockpiles any more than we have done already. We must also try to hold exercises during normal working hours to the extent this is possible. The nature of exercises may be changed and it is possible that both our own exercises and joint exercises with our allies will have to be reduced."

The defense chief denied that the economic problems are due to poor management of funds on the part of the armed forces. He said that much of the reason for the current situation is connected with the fact that the defense system is continually being assigned new jobs without sufficient attention being given to this circumstance in the annual budget. Hauge pointed out that last year's productivity campaign at the state level has had little savings impact on defense and said that the rationalization effort had been stepped up even before this campaign ended. "I still believe that within 5 years we will be able to save between 1.5 and 2 billion kroner, as I indicated last year. But it is important to get out of the situation we are in now, so that in the long run we can stabilize our activity at a lower level. Much can be gained if we succeed in forming our peacetime organization in such a way that we can accomplish the same or more overall but use less resources."

Hauge hopes he will meet understanding for this, especially in his own ranks. He said that unless the defense system gains control over the high operating expenses within a few years, it will have consequences for our readiness level. "Then we would have to make reductions in the 'cutting edge' of defense. This could involve units in all the defense branches," he said.

"To avoid further deterioration in the short run, increases in next year's budget must be at least as large as this year's. I think a larger increase would meet with little sympathy from the people. We must learn to operate our finances within the levels set by the authorities," the defense chief said.

6578  
CSO: 3639/156

## DEFENSE MINISTRY OFFICIAL URGES MEASURES TO RETAIN PILOTS

Oslo AFTENPOSTEN in Norwegian 4 Aug 83 p 4

[Article by Tore Tollersrud]

[Text] "We are doomed to lose the struggle for defense-trained pilots as long as civilian airlines can offer higher wages," said Oddmund H. Hammerstad, permanent undersecretary in the Defense Ministry. The inspector general of the air force, Major General Magne T. Sorensen, stated yesterday that the pilot "flight" is a matter of concern for the air force, to put it mildly, and he called for political steps to be taken.

Major General Sorensen told the NTB news agency that military circles have done what they can to alleviate the problem, but now it is the responsibility of the politicians to find a solution. The pilots are very impatient after having seen the results of the recommendations from the so-called Hammerstad group which presented its report at the beginning of the year after spending a few months evaluating the precarious problem of pilot flight.

Undersecretary Hammerstad said that the measures recommended in the report have already been implemented and that they would be effective in the current year. Among these implemented measures is the rule that the 3-year training at the Military Air School is now counted as part of the total mandatory service period, while previously it was in addition to 8 years of service.

Storting passed a revised officer system earlier which means that pilots come into the promotion system earlier than they used to. This has also eased the pressures of being moved around under the posting system.

In response to Major General Sorensen's challenge to the politicians, permanent undersecretary Hammerstad said:

"That is a one-sided criticism. It is also the responsibility of that defense branch itself to stimulate pilots to keep working for the air force through steps that increase job satisfaction."

Hammerstad explained that a large part of the problem lies in the fact that only the defense system trains pilots in Norway today. This training costs 3 million kroner per pilot. Training pilots for civilian flying would not be anywhere near as costly. Hammerstad disclosed that there is solid cooperation between the Defense Ministry and the Traffic Ministry to set up a civilian pilot training program in Norway.

Pilots have also received increased supplementary pay through the so-called B regulation and they have been given better opportunities to get housing loans, which will improve their situation on the housing market.

"The economic talks we are now holding in the organizations and in the ministries will take time," Hammerstad emphasized. "We must go through a vast negotiating hierarchy."

Major General Sorensen is especially concerned about the departure of experienced jet fighter pilots from the air force and the consequences this has on the quality of training in the air force.

"The defense system will constantly be in competition with the private airlines for the most capable pilots. Here the air force itself must put some muscle into solving the problem," Hammerstad maintained.

NTB revealed that from now until 1 April of next year the air force risks losing 18 pilots--most of them high up on the seniority list.

While SAS used to be the largest beneficiary of military pilots, Braathen's SAFE [expansion unknown] has now taken over that role.

Undersecretary Hammerstad maintained that pilot flight from the defense system is not a new problem. "The problem comes in waves and we are now at the peak of a wave," he said, but added that since 1979, the departure rate has been as high as the recruitment rate for pilots in the defense system.

6578

CSO: 3639/156

## SOVIETS REMOVE PARTS FROM CRASHED HELICOPTER ON SVALBARD

Oslo AFTENPOSTEN in Norwegian 25 Jul 83 p 4

[Article by Torill Nordent: "The Soviets Removed Parts from the Crashed Helicopter"]

[Text] Barentsburg, 24 July. The Soviet helicopter crash at Hornsundet on Svalbard 11 days ago was caused by human error. This was disclosed by Vice Consul Dimitrij Petrov at the Soviet Consulate in Barentsburg. An accident committee in Barentsburg will report to the district governor of Svalbard about further courses of events when the investigation is finished.

District Governor Carl A. Wendt in Longyearbyen confirms to AFTENPOSTEN that the Soviets were removing certain parts of the helicopter when the governor's helicopter arrived on the scene 5 or 6 hours after the accident. A ban was issued against continuing the dismantling of the equipment until the wreck could be released. This order from the governor was observed.

Now all the remains of the wreck have been removed from the scene. In order to transport the helicopter, it was divided into many parts and flown with another helicopter to a boat that ferried it back to the Kapp Heer base outside Barentsburg.

For the time being, the governor does not want to comment on the conclusion of the accident report. He disclosed that the flight was announced according to regular procedures but that the accident was not reported to the governor's offices. The accident was discovered inadvertently from the air when the governor was on an inspection trip. Wendt says that Soviet flights on Svalbard are reported regularly. "I have no concrete examples that the opposite has happened, even though it might very well have happened," he says.

Eight Poles and six Soviets were on board the helicopter that turned over on its side during landing. The Poles have their own research base at Hornsundet. None of the 14 on board were seriously injured.

The governor also decided that no pictures from the helicopter crash would be released.

"Nevertheless, pictures have surfaced and this is a negligence that cannot be traced back to my staff. We know who took the pictures and we will react to the fact that the governor's instructions were not observed," says Wendt.

## CIVIL DEFENSE STUDY COMMISSION URGES GAS MASKS FOR ALL

Oslo AFTENPOSTEN in Norwegian 4 Aug 83 p 3

[Article by Liv Hegna]

[Text] On the basis of the possibility that the civilian population might be hit by gas attacks in a war, contingency plans should be made against chemical warfare. To start off with, gas masks should be acquired for the entire population. These were some of the major conclusions in the report issued by a task force that has been looking into measures to protect the civilian population from chemical weapons. The task force estimated that there is a shortage of 3 million gas masks in this country and that it would cost an estimated 465 million kroner to acquire them, based on current price levels.

Research director Frode Fonnum of the Defense Research Institute has been chairman of the task force that evaluated chemical weapons. The secretary of the task force, John G. Martinsen of the Directorate of Civil Defense, stated in the latest issue of the periodical SIVILT BEREDSKAP that a secondary recommendation of the task force was that full protective gas masks be acquired only for people in especially exposed areas, while "half masks" should be acquired for the rest. Such masks protect the nose and mouth, but not the eyes or the rest of the face. Martinsen did not specify who would select the segment of the population that is entitled to full protection gas masks and how distribution would be handled if it became necessary to issue them. However, it can be stated unequivocally that establishing priority criteria would be a very difficult political problem when one goes beyond issuing masks to the combat forces and to high priority groups such as the government and Storting representatives.

Another conclusion reached by the task force is that providing gas masks cannot be viewed in isolation. It is also necessary to develop and prepare other forms of defensive measures such as detection and warning, mass measures such as shelters, medical preparedness and treatment, including hospital readiness, plus information and training. Building up preparedness for gas attacks requires an effort in all these areas, which the task force estimated would cost around 25 million kroner.

An important aspect of the task force's evaluation concerns the relationship between protective masks and emergency shelters. The group's conclusion was that shelters that can keep out gas cannot replace gas masks, which is due primarily to the fact that chemical weapons would spread rapidly over large areas before people could reach emergency shelter rooms. In addition, attacks with chemical weapons would often be combined with attacks by conventional weapons. During such attacks, many people would be better protected in cellars and so forth, rather than trying to get to shelters.

In connection with the issue of shelter space, the group pointed out that many of the shelters are in poor condition and that in general they would offer inadequate gas protection, even if they are equipped with filter ventilation. Thus the group recommended that to start out with, a critical review of all emergency shelters be made in order to clarify what should be done to bring them up to satisfactory standards.

The task force also stressed that knowledge of chemical weapons and protection against them is "deplorably low" among the population. This could lead to a larger loss of life among the civilian population than would be the case if the general level of knowledge was higher. Therefore the group recommended that greater stress be given to information about chemical warfare through the preparation and distribution of brochures as well as contact through the mass media.

6578  
CSO: 3639/156

MILITARY

SWEDEN

BRIEFS

CIVIL DEFENSE ORDERS PROTECTIVE MATERIAL--The Civil Defense Administration has ordered protective jackets for children and protective masks for 35 million kronor from Trelleborgs AB's factory in Ystad. The jackets will protect against discharges and poisonous gases and thus have a built in protective mask. The shipments are estimated to continue until, and include, 1984. [Text] [Stockholm DAGENS NYHETER in Swedish 22 Jul 83 p 7] 9843

CSO: 3650/253

## ANKARA WORRIED OVER IRANIAN THREAT TO OIL PIPELINE

Istanbul CUMHURİYET in Turkish 3 Aug 83 pp 1,11

[Text] Ankara--It is reported that the Turkish and Iraqi economies may suffer severe losses--though to different scales--if the [Turkish-Iraqi] pipeline is disabled. Iranian military units have declared that they may bomb the pipeline in the course of the operation they have launched against the Kirkuk region.

Turkish authorities believe that the entry of Iranian units into Iraqi territory some time ago and their advance toward Kirkuk have brought the war to a "serious" point. Consequently, the continuing Iranian operation is a subject of constant evaluation in Ankara.

Even so, Ankara is apparently still committed to its policy of "neutrality" which it has adopted since the beginning of the war. The latest indication of this was that Foreign Minister Ilter Turkmen, during his press conference two days ago, constantly referred to both countries together and never attacked Iran directly.

Various evaluations are under way in Ankara in connection with the latest Iranian operation. One such evaluation says that the goal of the Iranian operation is to enter Iraqi territory, to "isolate" elements in Iraq providing support to secessionist groups in Iran and to break the ties between these two groups. According to another evaluation, the goal of the Iranian operation is to keep the Kirkuk oil region and the pipeline--the lifelines of the Iraqi economy which has been having problems as a result of the war--under a constant strategic threat. Iraqi warplanes have in the past attacked Kharg Island, a shipping center for a major portion of Iran's oil exports, and have bombed Iranian oil tankers. It is reported that Iran wants to keep Kirkuk under threat as a countermeasure against Iraq.

Ankara indicated its stance clearly through Foreign Minister Turkmen two days ago in connection with the Iranian operation against Kirkuk and statements by Iranian officials on this issue. Responding to questions on the issue, Turkmen said: "Iraq and Iran must not undertake any moves in their war which may hurt Turkey's interests." This diplomatically phrased statement was expressing the hope that Iran would not attack the pipeline.

The pipeline, which went into operation 7 years ago, carries the crude oil from Iraq's oil-rich Kirkuk region to Yumurtalik in Turkey where it is loaded on

tankers to be exported. The closure of the Persian Gulf to Iraqi oil exports since the beginning of the Iran-Iraq war has made Iraq dependent on the Kirkuk-Yumurtalik pipeline for moving its oil. As a result of this situation, the pipeline which operated at below capacity in its initial years has been operating at full capacity (35 million metric tons per year) recently and has become the only outlet for Iraq's oil which is virtually that country's only export item.

If the pipeline is disabled by bombing, the Iraqi economy, which is already having difficulties, may be completely paralyzed.

#### Effect on Turkey

The disabling of the pipeline may manifest its effects on Turkey in two forms. Firstly, Turkey will be deprived of the transit revenues it collects from the 980-kilometer pipeline, 640 kilometers of which passes through Turkey. Turkey's royalty revenues from the pipeline amount to around \$100 million.

Secondly, Turkey's oil imports from Iraq may be seriously scuttled. Turkey has signed a contract with Iraq to import 7 million metric tons of oil a year. Last year, only 5 million metric tons of this quota were used. In view of the fact that Turkey imports a total of 15 million metric tons of oil each year, a slowdown or a halt in oil deliveries from Iraq may cause various difficulties for Turkey.

Last year, Turkey and Iraq agreed to raise the capacity of the oil pipeline from 35 million metric tons to 45 million metric tons a year and started work on the technical level. Initially, it is planned to make the crude oil to be pumped more fluid and thus to increase the amount to be pumped by adding special chemicals to the oil. However, this method would add \$1 per barrel to the cost of oil. In the second stage, elbow points on the pipeline will be enlarged to enable the oil to flow faster. According to information obtained from officials, work on this issue is progressing at a slow pace.

9588

CS: 3554/398

## ANALYSIS OF ANKARA APPROACH TO U.S.-GREEK BASE ACCORD

Istanbul CUMHURIYET in Turkish 2 Aug 83 p 12

[Report by Sedat Ergin]

[Text] Ankara--The uneasiness caused to Ankara by the concessions made by the United States in connection with the balance of forces in the Aegean in the new U.S.-Greek agreement on bases does not appear to have turned into a concrete reaction.

Before the agreement was initialed 2 weeks ago in Athens, Ankara warned Washington on several occasions through Foreign Minister Ilter Turkmen and announced that in the event Turkey is mentioned directly or indirectly in the agreement "the United States will lose much more in its relations with Turkey than the advantages it will secure in its relations with Greece."

The fact that the United States referred to the foreign aid law--which provides for "a balance of power between Turkey and Greece"--in the agreement despite repeated warnings by Turkmen placed Ankara in a dilemma. Ankara had two options:

- 1) Ankara would either take a posture which would make the Turkish reaction felt concretely in Turkish-American relations as Ankara had committed itself to in public;
- 2) Or, Ankara would have "to resign itself" to this development.

In his first meeting with U.S. Ambassador Robert Strausz-Hupe, Turkmen expressed "regret" at the development and stated that it opens the way for exploitation by Greek Prime Minister Andreas Papandreu. However, at that time Turkmen restricted the views conveyed to his personal opinions; he would convey the government's opinion later.

#### Intensive Talks

After this meeting between Turkmen and Strausz-Hupe on 18 July, Turkish Ambassador in Washington Sukru Elekdag conveyed to U.S. Deputy Secretary of State Richard Burt on 23 July the Turkish government's views on this issue, which embodied the views expressed by Turkmen.

This move by Turkey in Washington was reinforced by a much higher-level move in Ankara the same day. Deputy Chief of the General Staff Gen Necdet Oztorun invited U.S. Ambassador Strausz-Hupe to his office and expressed Ankara's concerns "on

behalf of the highest authority." The diplomatic traffic between Turkish and U.S. officials on this issue continued into last week. Ambassador Strauzs-Hupe was summoned to the Ministry of Foreign Affairs again on 25 July. The same day, Turkmen had another meeting with Ambassador Ercument Yavuzalp, the Undersecretary of the Foreign Ministry.

The following picture emerged from the series of talks conducted by diplomats: The U.S. side stated that as far as the administration is concerned it is opposed to the implementation of the 10 to 7 ratio used in assistance to Turkey and Greece and that, furthermore, Greece was not given the guarantees it sought for the security of its borders. The U.S. side said: "The change in the Foreign Assistance Act, to which reference is made in the agreement and which embodies the concept of a balance of power between Turkey and Greece, has been in effect since 1978 and is nothing new. Furthermore, the sentence following the section of the agreement where the said reference is made says that the assistance to be provided to Turkey for its NATO commitments will not be affected by this provision. This is an expression that rises above the concept of balance of power."

The Turkish side reiterated that it was "opposed to any mention of Turkey even indirectly" from the outset and stated that it does not find the explanations given "satisfactory and clear." In response, the U.S. side tried to draw Ankara's attention to the assistance to be provided in the fiscal year 1984 and stated that passing this assistance package through Congress is more important than anything else and that the Reagan administration will do its utmost to pass the bill through Congress in its proposed form.

#### 'Minimum Concession Made to Papandreou'

Another issue explained by the U.S. side was that the initialed agreement meets the "minimum" of Papandreou's demands. However, according to stories circulating in diplomatic anterooms, the said agreement falls far short of the agreement the United States concluded with the conservative Rallis government which was in power before the Papandreou government. That agreement could not be finalized as a result of the elections in Greece.

It cannot be said that Ankara is fully satisfied with these explanations of U.S. diplomacy. It is this point that gives rise to Ankara's dilemma. While the United States cannot be expected to change its position, Ankara is unable to accept the concessions made by the United States to Greece, but, on the other hand, it cannot take a stand against the United States at a time when \$715 million in assistance is being discussed by Congress.

9588

CSO: 3554/398

## SEP, MBB 1982 STUDIES ON CRYOGENIC ENGINE FOR 1990'S ARIANE

Paris L'AERONAUTIQUE ET L'ASTRONAUTIQUE in French No 99, 1983-2 pp 70-77

[Article by S. Eury, M. Pouliquen (SEP) and J. Borromee (French National Space Studies Center): "The Current Status of Studies of the High Thrust HM 60 Hydrogen/Oxygen Engine"]

[Excerpts] [Summary as published in English] Long term studies made by CNES [National Space Studies Center] concerning future launching systems after Ariane IV showed the necessity to develop, for the beginning of the nineties, a new high thrust cryogenic (LOX-LH<sub>2</sub>) rocket engine. Studies conducted jointly by CNES, SEP [European Propulsion Company], MBB [Messerschmitt-Bolkow-Blohm] and Volvo in 1980 and 1981 led to the main specifications of the engine (900 KN thrust, 5.1 mixture ratio, 445 s specific impulse, 4 m length, 1,350 kg weight). For the performance level specified, a gas generator cycle engine, composed of:

--a combustion chamber with a nozzle extension

--two separated turbopumps

--a single gas generator

permits, through a relatively simple, traditional and modular design, a lessening of development risks, delays, and development expenses.

Present studies are based on a 100 b combustion pressure, regeneratively cooled combustion chamber, dump cooled tube construction nozzle extension using the same technology as the HM7.

The two turbopumps are separated and fed in parallel from a single gas generator. The LH<sub>2</sub> turbopump has an inducer, two stages centrifugal pump and a two stages turbine with a shaft speed near 40,000 RPM. The LOX turbopump also has

an inducer, one stage centrifugal pump, two stages turbine, a shaft speed of 15,000 tr/mn. The gas generator combustion pressure is 77 bars and the liquid/liquid injection is obtained from quintuplets impinging elements.

## Introduction

Forward-looking studies by the CNES into the needs of future launching systems beyond Ariane 4 have brought out the necessity of developing, for the beginning of the 1990's, a high-thrust LOX-LH<sub>2</sub> [liquid oxygen-liquid hydrogen] cryogenic engine.

This engine would be used, successively, as follows: Initially, as a disposable second stage, then as a disposable first one-and-one-half stage, and finally as a recoverable launcher.

The design of this engine must therefore satisfy the following criteria:

- High operational performance in an environmental vacuum;
- Minimal production cost;
- Completion of its design and qualification within a time span and at a developmental cost that will be acceptable to Europe.

From among the various design studies carried out by CNES, SEP, MBB and Volvo, in 1980 and 1981, the best compromise among these contradictory requirements was found to be the choice of a shunt-flow engine whose performance can be enhanced, if necessary, by means of a deployable divergent nozzle.

## Ariane Family

Work during 1982 has had as its objectives the completion of a preliminary design of the engine in a basic configuration, the start of technological testing of components (bearings, dynamic seals, etc), and the study of design variants.

## Specific Design Objectives

The principal specifications of the engine are:

Thrust:	900 KN [kilo-Newtons]
Mixture ratio:	5.1
Design ISP [specific impulse]:	445 seconds
Weight:	1,350 kg
Length:	4 meters.

But the HM60 engine is to be designed to be produced at minimum cost. Supplementary design thereafter can be added to incorporate re-ignitability and usability for manned flights.

#### Choice of Principal Operating Characteristics

For a rocket engine, ISP performance depends primarily on:

--Section ratio of the divergent nozzle, which in turn is a function of:

- Space allocated to the engine. The design length adopted was 4 meters. Its outline is to be 80-percent "bell-shaped";
- Combustion pressure, which has been chosen to be 100 bars, based on a parametric study of the optimum for a shunt-flow engine;
- Mixture ratio, which has been optimized at 5.1 for maximum performance in geostationary orbit, taking into account performance of the engine and weight of the stage's propellant tanks;
- Efficiencies of combustion and of thrust of the chamber and or the divergent nozzle, which have been estimated at an overall figure of 0.967;
- Performance losses owing to cooling of the divergent nozzle by the dump-cooling method, estimated at 2 seconds;
- Performance losses owing to the shunted flow, the ISP of the gases in which is lower than that of the gases in the chamber. The flow rate of the shunt-flow gases must be minimized:
  - Either by increasing the enthalpy of these gases produced in the generator,
  - Or by increasing the efficiency of the turbopumps.

The efficiency of the hydrogen turbopump depends primarily on the circumferential speed of the turbine blades, which has been limited to 450 m/sec.

The efficiency of the oxygen turbopump is low because of the speed of rotation, which is limited by cavitation inside the pump.

#### General Architecture of the Engine

To best respond to the formulated requirements, the engine will be of a relatively simple, conventional and modular design intended to minimize risks, development times and development costs.

The design is based on seeking the best compromise between cost of producing the engine and its performance in terms of ISP under operating conditions in a vacuum. The HM60 is an engine fueled by cryogenic propellants LOX and LH<sub>2</sub>, and operating according to a shunt-flow cycle. The propellants are pressurized by two independent turbopumps that are fed in parallel by a gas generator.

The propellants of the primary flow are injected into a combustion antechamber directly from the output of the pump in the case of the oxygen, and after going through a regenerative circuit in the case of the hydrogen.

The hot gases resulting from their combustion provide the engine's primary thrust inside a single convergent-divergent exhaust nozzle.

The gases that drive the turbopump turbines are produced in a gas generator by burning, at a low mixture ratio, propellants drawn from the pump outlets. After passing through the turbines, these gases are ejected separately through two convergent-divergent nozzles, providing additional thrust.

--The engine does not have a booster pump upstream of the main turbopumps, which are therefore dimensioned for adequate intake performance;

--The combustion chamber is regeneratively cooled, that is, by liquid hydrogen before its injection into the chamber;

--The divergent nozzle is cooled by the dump-cooling method, that is, by means of the hydrogen that is ejected at the downstream end of the divergent nozzle tubes, where they provide an additional thrust;

--The gas generator and the turbine blades are not cooled;

--The chamber and generator are ignited pyrotechnically;

--The engine is started by means of a solid-fuel starter;

--The specified values of mixture ratio (at the pump intakes and in the generator) and thrust are obtained by setting the engine control adjustments on the ground, at the test bench, using an automatic regulating system; the commandable components of the engine are then locked into their proper adjustment for the flight; only a three-position "hot gas" valve, located between the generator and the LOX turbine, is operated during the flight to ensure a complete and simultaneous emptying of the stage's fuel tanks.

#### Oxygen Turbopump

The oxygen turbopump consists of an inducer, a centrifugal pump stage and a two-stage impulse turbine.

The inducer and the pump are made of an aluminum alloy; the turbine and shaft are of INCO 718.

The bearings are placed between the inducer and the pump, and between the pump and the turbine disks. The pump bearings are cooled by the oxygen supply, and the turbine bearings by the hydrogen supply, thus minimizing the cantilevering of the turbine.

An absolutely leakproof seal between the pump and the turbine is obtained by means of floating-bushing seals, a helium barrier and draining. A retractable seal is used to prevent hydrogen leaks toward the turbine during the precooling of the turbopump prior to its start-up.

Dynamic balancing of the axial forces is accomplished by the variable pressure obtained by gauging downstream of the pump.

The speed of rotation of the turbopump is lower than the first critical speed.

#### Hydrogen Turbopump

The hydrogen turbopump consists of an inducer, two centrifugal pump stages in tandem, and a two-stage pressure turbine.

Owing to the very high power transmitted by the shaft and the high speed of rotation, the ball bearings are located outside the pump and the turbine, so as to limit the  $DxN$  values. The bearings are cooled by the liquid hydrogen supply.

As in the case of the oxygen turbopump, two retractable seals are used to prevent hydrogen leaks toward the turbine during precooling.

The axial-forces dynamic balancing system is located on the rear face of the second impeller of the pump.

The inducer is made of an aluminum alloy, the flanged pump impellers of a titanium alloy, and the turbines and shaft of INCO 718.

The speed of rotation is set between the second and third critical speeds.

#### Combustion Chamber

##### Thrust Chamber (MBB)

The thrust chamber consists of a cardan, an injector, a combustion chamber and a divergent nozzle. The injector consists of 516 constituent coaxial injectors mounted on a sweat-cooled porous faceplate.

Some of the injectors that extend beyond the faceplate form baffles which damp some of the fluctuations in combustion pressure; acoustic cavity resonators placed around the chamber complete the combustion anti-instability system.

The cylindrical combustion chamber plus convergent-divergent nozzle, out to a sectional ratio of 6, is regeneratively cooled. It is made of machined copper-alloy cooling ducts bound together externally by an electrolytically deposited copper sheathing over which a nickel cladding is then electrolytically deposited.

The hydrogen intake and exhaust manifolds are laid back on and welded to the nickel cladding. To limit the height of the ducts and make their machining possible, cooling is done by a fraction of the total hydrogen flow, which then mixes with the rest of the flow in the intake doughnut of the injector.

The detachable divergent nozzle consists of rectangular-sectional tubes made of Inconel, that are cooled by part of the hydrogen supply which is then ejected at the end of each tube. The tubes may be braised or welded together.

### Gas Generator

The gas generator produces the hot gases that parallel-feed the two turbo-pumps by combustion of a low-ratio mixture of hydrogen and oxygen tapped from the pump outlets.

The gas generator consists of an injection head and a combustion chamber body.

The injection faceplate contains 120 uniformly distributed quintuplet elements, and provides distribution at a uniform mixture ratio. Each injection element consists of an axial LOX orifice and four converging LH<sub>2</sub> orifices, the flow through each element being regulatable.

The LOX intake manifold and injection chamber have been designed to ensure a perfectly homogeneous feed through each LOX injection orifice and to damp the starting and stopping transients.

The hydrogen enters a toroidal manifold before flowing radially into the H<sub>2</sub> injection chamber.

Ignition is effected by a pyrotechnic igniter mounted at the center of the injection faceplate. The injection faceplate is made of Z2 CN18-10, and is of monobloc design; the injection chamber is electron-discharge machined; the injection orifices are electron-discharge or mechanically machined. The LOX intake manifold is made of Inconel 718; it is electron-beam welded to the injection faceplate.

The cylindrical combustion chamber is cooled by circulation of hydrogen in a double wall.

The outside wall, made of INCO 718, provides structural strength; it is secured at its top end to the injector, and at its bottom end to the hot-gas piping, by means of nut-and-bolt harnesses for the developmental phase. The INCO 625 double wall contains nine acoustic cavities to damp any potential combustion instabilities.

The hydrogen used for cooling is injected into the combustion gases at the lower end of the combustion chamber.

## Conclusion

The HM60 is to be the main engine of the future European space transport systems; this is why the choices being made now from the standpoints of design and technologies are crucial to Europe's ability to compete in this domain. The need to combine good performance with low production cost and an acceptable cost of development has led to the adoption of an overall design that is straightforward and modular, but that is based on a high level of pressure for a shunt-flow cycle engine.

[Tables and drawings follow]:

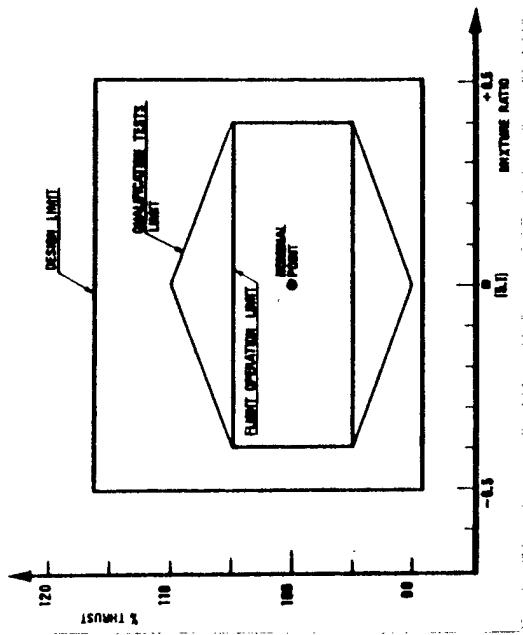

Fig 2 - Thrust/mixture-ratio design and operating limits.

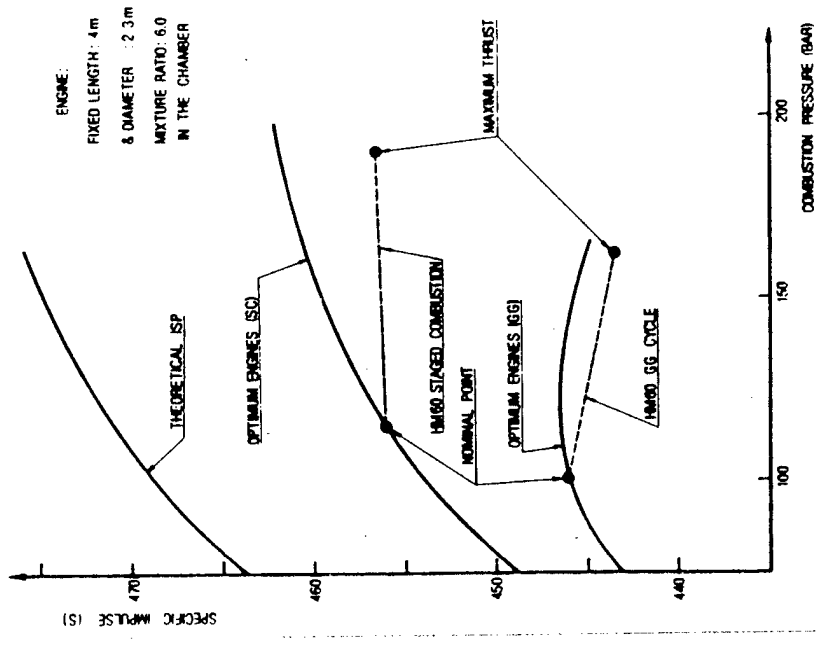

Fig 4 - Specific impulse in vacuum.

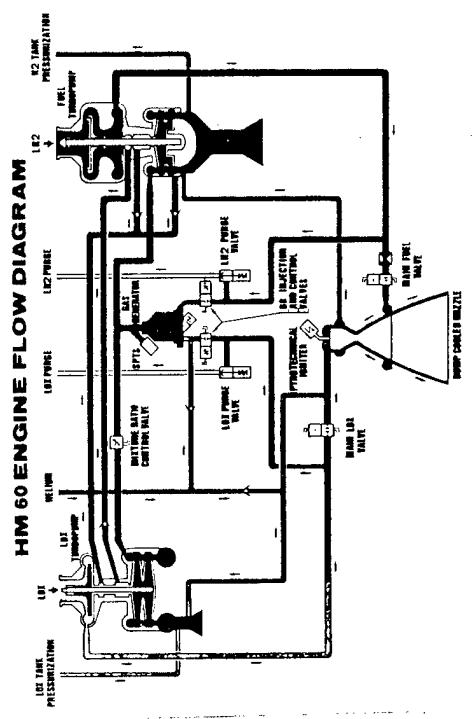

Fig 5 - HM 60 Engine flow diagram.

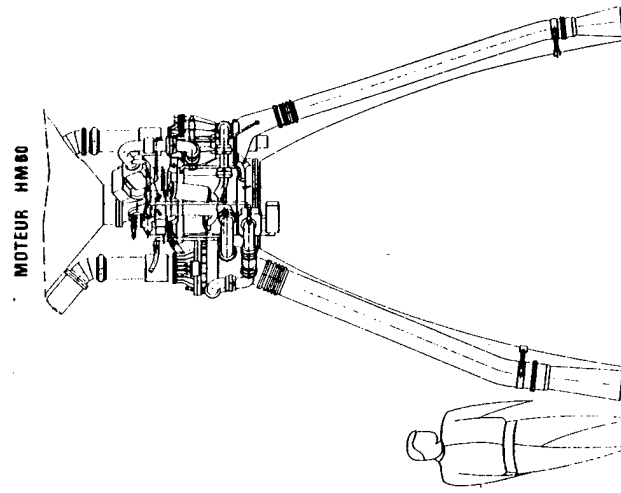

Fig 6 - HM 60 Engine.

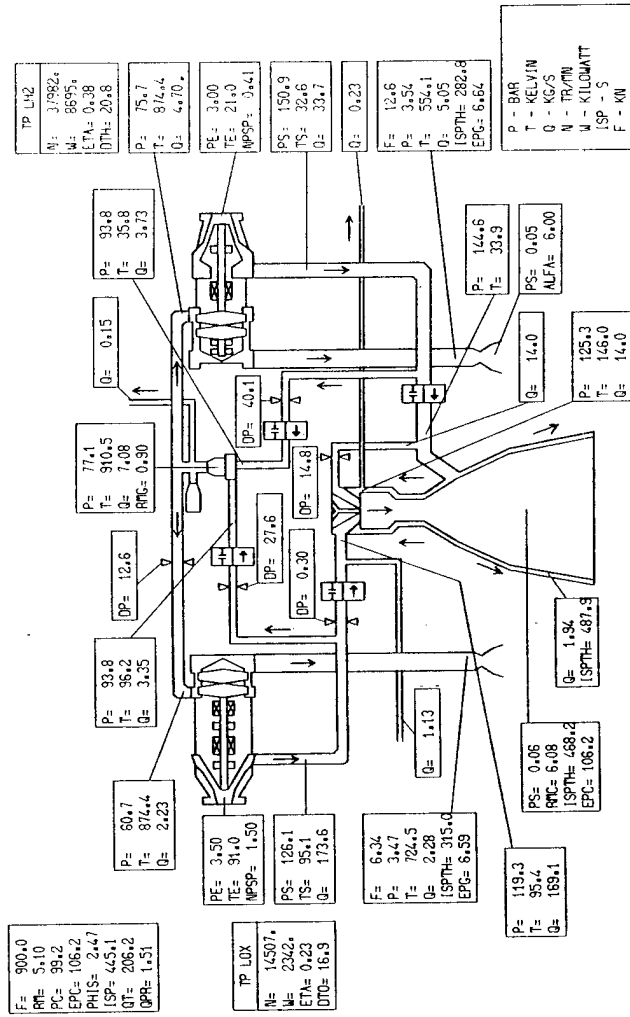
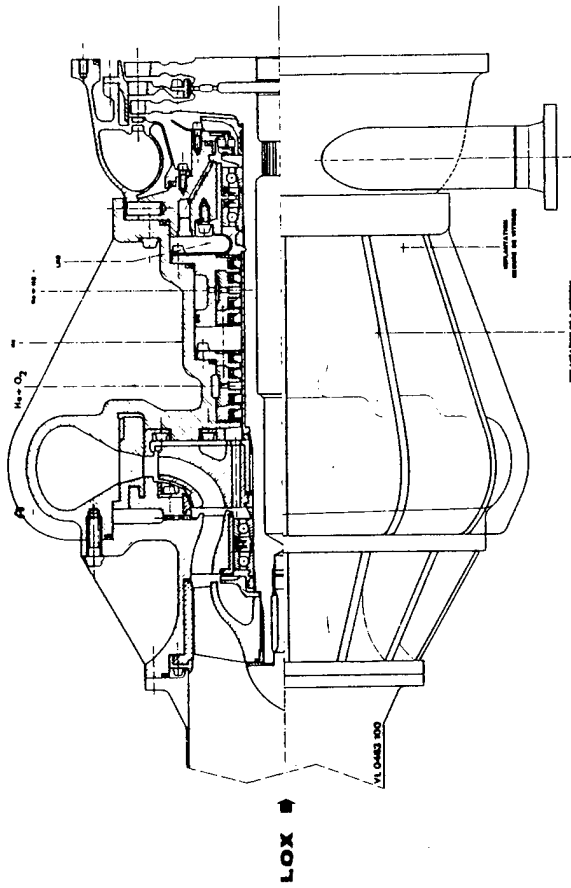
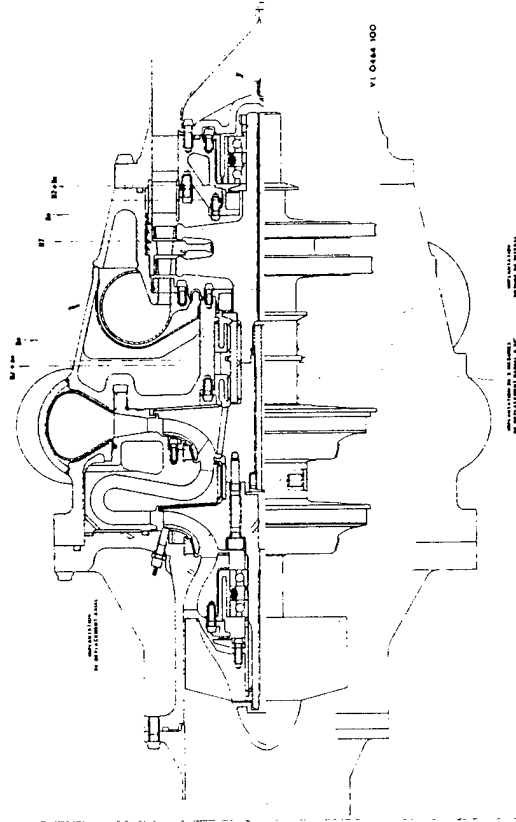

Fig 7 - "HM 60" Operating point for Shunt-Flow Engine 1, Generator MC 5.



[Left]: Fig 8 - Oxygen turbopump.



[Right]: Fig 9 - Hydrogen turbopump.

[Uncaptioned table as published]

<u>Item</u>		<u>LOX Turbopump</u>	<u>LH2 Turbopump</u>
Speed of rotation	rpm	14,500	38,000
Output	kg/sec	173.6	33.7
Pressure at pump exit	bars	126	151
Power	kW	2,340	8,700
NPSP* [expansion unknown; asterisk unrefer- enced as published]	bars	1.5	0.5
<u>Pump</u>			
Number of stages		1	2
Impeller diameter	mm	205	205
Efficiency		0.80	0.77
<u>Turbine</u>			
Number of stages		2	2
Diameter	mm	230	200
Pressure ratio		17.5	21.4
Efficiency		0.29	0.50

Injector: Comparison of Design Parameters

Item	MBB	
	HM 7	Experimental Thrust Chamber HM 60
Total injector output	kg/sec 13.9	45 195.8
Chamber diameter	mm 180	182 415
Number of elements	90	90 516
Output per element	g/sec 70.7	470 380
H <sub>2</sub> Injection temperature	K 136	190 97
Design efficiency*	0.986	0.98 0.991

\* [unreferenced as published]

Combustion Chamber: Comparison of Design Parameters

Item	MBB	
	HM 7B	Experimental Thrust Chamber HM 60
Chamber inside diameter	mm 180	182 415
Characteristic length	m 0.7	2.3 1
Contraction ratio	2.78	6.95 2.99
Cooling-medium temperature rise	K 100	140 63
Cooling charge loss	bars 5.7	100 19.7
Maximum wall temperature	K 625	690 675
Maximum heat flux	W/cm <sup>2</sup> 2,900	16,800 6,400
Combustion pressure	bars 35	280 100

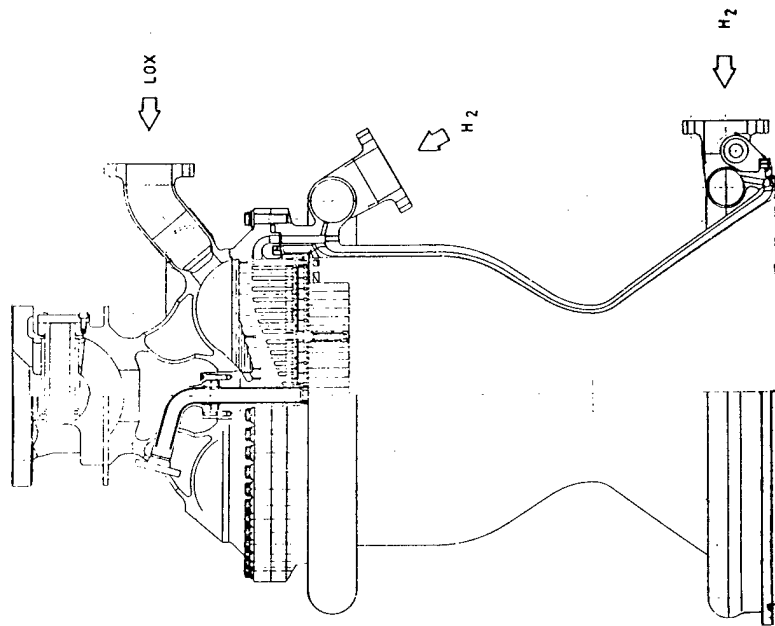

Fig 11 - [uncaptioned as published]

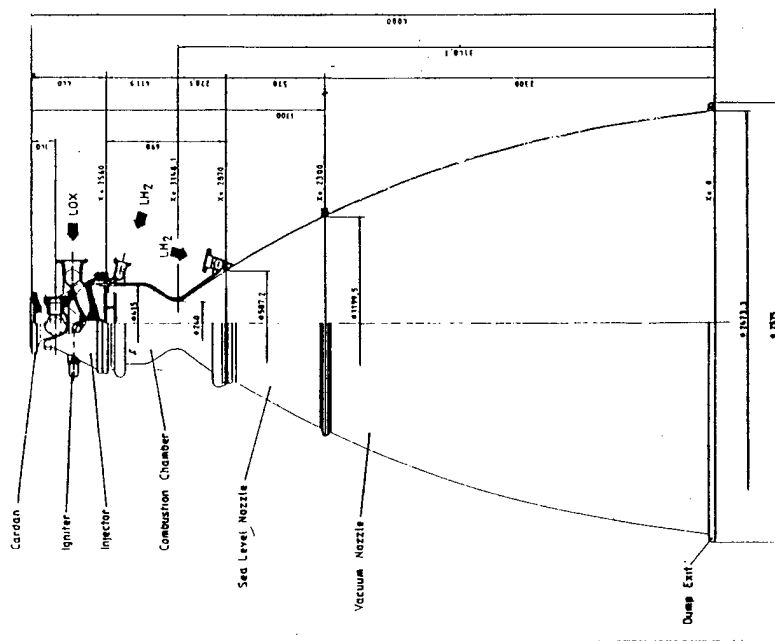

Fig 10 - [uncaptioned as published]

Gas Generator Nominal Operating Point

<u>Item</u>	<u>Value</u>
Total combustion pressure	77.1 bars
Combustion temperature	910. K
Mixture ratio	.9
Total hot gases output	7.08 kg/sec

9399

CSO: 3519/553

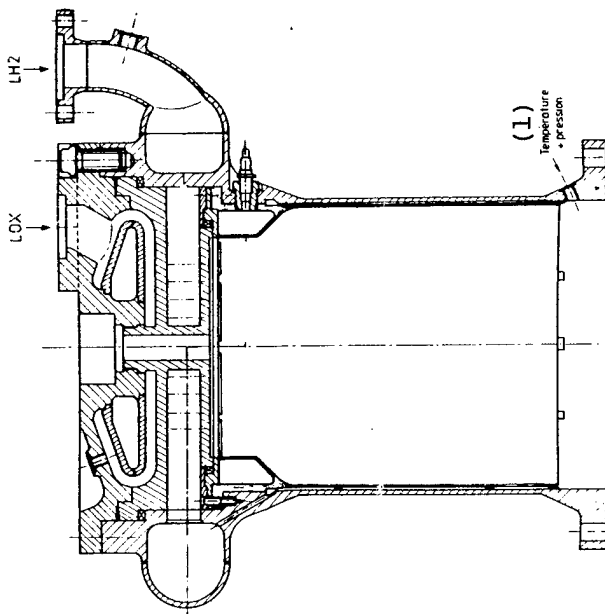

Key:  
 1. Temperature and pressure.

Fig 12 - HM 60 Gas Generator

Gas Generator Geometry

<u>Item</u>	<u>Value</u>
Inside diameter of injection faceplate	125 mm
Inside diameter of combustion chamber	160 mm
Injection element	quintuplet
Number of elements	120
Injection faceplate material	Z2 CN 18-10
Length of chamber	225 mm

## SWEDEN'S FOREIGN MINISTER ON KATTEGATT DISPUTE WITH DENMARK

Stockholm DAGENS NYHETER in Swedish 25 Jul 83 p 7

[Article by Birgitta Edlund: "Sweden's Decision Waits; the Riksdag Must Decide"]

[Text] The Swedish-Danish conflict over the border of the two countries threatens to be lengthy. Foreign Minister Lennart Bodstrom made this clear at a meeting last Sunday at Ljugarn on Gotland.

Although discussions on the border question are to begin shortly, Sweden cannot come to a definite decision until the Riksdag has had its say.

At the end of August, the two chief legal advisers of Sweden's and Denmark's Ministries for Foreign Affairs will meet to discuss the opinions of the two countries about how the border outside the Danish island of Hesselø in Kattegatt is to be drawn. A Danish oil company will probably have started exploratory drillings in the disputed area by then; the Danish government has given the company permission to start drilling at the beginning of August.

#### Takes a Long Time

But, Lennart Bodstrom emphasized last Sunday, border questions are Riksdag questions. The foreign affairs committee must, for example, be heard in the question, which therefore will not be solved for a long time.

Bodstrom was eager to deemphasize the conflict between the countries. It was, he said, not a matter of a letter of protest when Sweden, on 13 June, sent its ambassador in Copenhagen with a communication to the Danish Ministry for Foreign Affairs. This was 6 days after Denmark had given the go-ahead for the exploratory drillings.

"It was more of a written reminder of where the Swedish government stands on the question," said Bodstrom.

"The Danish oil company has not started drilling yet," he said.

The Swedish government feels that the border between Sweden and Denmark goes at Hesselö island, and that the Danes consequently will be drilling for oil in Swedish waters. According to Sweden's point of view, Hesselö lacks a permanent population, and thus the Swedes do not want to draw the midline between Hesselö and the Swedish mainland, but the Danes do.

#### Denmark Compares

The Danes feel, however, that the Hesselö case should be compared to the Swedish view of the border question between Sweden and the Soviet Union. In that case Sweden considers the border to be outside Gotland in international waters, while the Soviet Union wants to draw it right next to Gotland.

Little Hesselö, Sweden maintains, cannot be compared to Gotland, which is a district with more than 50,000 inhabitants.

"There is no ambiguity whatsoever in the Swedish approach to the border question," he said.

While the ants crawled on reporters and the foreign minister, and a happy trio from the west coast drowned out all living things in the vicinity with their Taube songs, the foreign minister also discussed whether Swedish Ball-Bearing Factory (SKF) would get permission to invest in South Africa.

#### No Precedent

Bodstrom told that the minister for foreign trade, Mats Hellstrom, is investigating the question and found it strange that the non-Socialist government could refuse SKF's request for investments in South Africa a few years ago.

"There is hardly a precedent for it," said Bodstrom.

He also said that it is hard to establish what should be considered totally new investments and that fraud is always possible.

"Those Swedish companies already in South Africa should be allowed to stay, hopefully at some time to benefit the free South Africa," the foreign minister said. He also called attention to the fact that several investigations of the establishing of Swedish companies in South Africa are taking place; there is, for example, Ambassador Sverker Astrom's one-man investigation which will probably deliver its report around Christmas at the earliest.

This was the first appearance of the foreign minister as a member of the government on Gotland. It was a quiet family party, where many of Ljugarn's pensioners drank coffee and listened. Families with small children on the grass brought picnics and the children played ball, while the adults listened to peace appeals and explanations of what Swedish non-alignment means.

The peace movement is very strong on Gotland. Last Friday a peace bulletin went from the southern part of the island to the northern part. It was signed by a number of individuals and organizations and will be given to Foreign Minister Bodstrom at the beginning of the week.

## SWEDISH EXPERT SUPPORTS DENMARK IN KATTEGAT OIL DISPUTE

Stockholm DAGENS NYHETER in Swedish 12 Aug 83 p 2

[Article by Goran Melander, associate professor at Lund University]

[Text] The Danish test drillings for oil near Hessel Island do not conflict with current principles of international law. So claims Goran Melander, associate professor of international law at Lund University, as he begins a debate here concerning the so-called oil war between Sweden and Denmark. Melander points out that in its note of protest, the Swedish Government bases its position on a convention on the law of the sea that has not yet entered into force. The convention that applies--the 1958 Geneva Convention on the Continental Shelf--entitles the Danes to uphold the so-called median line principle.

In Sweden's note of protest to the Danish Government concerning the boundary dispute over rights on the continental shelf in the Kattegat, it is claimed that the Danish course of action conflicts with applicable principles of international law "as they find expression, for example, in the Convention on the Law of the Sea that was adopted in 1982." The statement is worded in such a way that one might be misled into believing that the convention in question must be applied in resolving the dispute and that Denmark is violating international law.

But the 1982 convention can be disregarded, not only in the dispute with Denmark but also in the dispute with the Soviet Union, the reason being that it has not entered into force. It has not been acceded to by Sweden, Denmark, or the Soviet Union. The 1982 Convention on the Law of the Sea can so far be regarded only as a proposal for regularizing the law of the sea.

For it to enter into force, 60 states must have declared their willingness to submit to the convention's stipulations, which then become binding on those states--but naturally not on any states that refuse to sign the 1982 convention.

Regarding the right to the continental shelf--that is, the seabed and whatever lies beneath it--another convention (the 1958 Geneva Convention on the Continental Shelf) applies. That convention is in force, and it is binding on Sweden, Denmark, and the Soviet Union.

In the case before us here, therefore, the boundaries between the continental shelves of the states must be drawn in accordance with the 1958 convention. Against that background, it is strange that the 1958 convention is not even mentioned in the Swedish note of protest.

That convention contains a reasonably clear definition of what is meant by "continental shelf." The interesting thing in this connection is that even islands have continental shelves, and that without any restriction. It is expressly stated in the convention that the continental shelf consists of "the seabed and subsoil of similar submarine areas adjacent to the coasts of islands."

It should be observed that under the 1958 convention, there is no requirement at all that an island have its own economic life. That idea finds expression, if anywhere, in the 1982 Convention on the Law of the Sea, which has not entered into force.

The 1958 convention also contains rules as to how the boundary between the continental shelves of two states is to be drawn. The principle of the median line is to be followed--that is, the boundary is to be halfway between the two states. Since islands have their own continental shelves, a state can use islands as the base line in drawing those median lines.

If the rules in the 1958 convention are applied to the dispute between Sweden and the Soviet Union, the median line will have to be drawn between Gotland and the Soviet Union. So in this case, Sweden is right. There is actually nothing to negotiate. And no concessions from the Swedish side--for example, even talking about a "gray zone"--should be made.

If the rules in the 1958 convention are also applied to the dispute with Denmark, it means that Denmark is right. The Danish islands of Hessel, Laes, and Anholt have their own continental shelves, and the median line should be drawn between those islands and the Swedish mainland.

Against that background, it might also seem strange that the Swedish Government is reacting so sharply only because the test drillings are being initiated from the Danish side. Denmark is naturally not guilty of any arbitrary course of action. It is merely occupying an area which, according to the 1958 convention, constitutes part of the Danish continental shelf.

In connection with the dispute with Denmark, it has been suggested that the International Court of Justice in The Hague be allowed to decide where the boundaries for the continental shelf should be. In itself, such a solution is possible, since the court in The Hague is intended for just that type of dispute between states.

But there are certain restrictions on the court's possibilities for deciding disputes between states. For one thing, there is no way to force states to appear before that court. The simple fact that a state is a member of the United Nations--the court is, of course, a principal organ of the United Nations--does not mean that the court can deal with a dispute. In one way or another, the states taking litigation before the court must voluntarily accept

the court's jurisdiction. A state can either do so after a dispute between states has arisen or agree to accept the court's jurisdiction beforehand--that is, before any dispute has arisen.

Sweden and Denmark have both expressed their willingness to accept decisions by the International Court of Justice. As a result, there is nothing at all to prevent either of the states from taking the dispute over the continental shelf before the court, and if that happens, the other state cannot refuse to reply to the charge. After that, the international court would be able to resolve the dispute.

No similar possibility exists, however, as far as disputes between Sweden and the Soviet Union are concerned, since for various reasons, the Soviet Union refuses to allow the court to resolve any dispute to which it is a party.

Let us therefore assume that the dispute between Sweden and Denmark is taken up by the court and that Sweden loses its case--in other words, that the International Court of Justice confirms the rule in the Convention on the Continental Shelf that islands have their own continental shelves and says that the principle of the median line must prevail.

That decision would be binding only on Denmark and Sweden--not on the Soviet Union. But such a result ought to give the Swedish Government backbone and lead to a more definite rejection of any demand from the Soviet side concerning rights to what the Soviet Union sees as a disputed area in the Baltic Sea.

11798  
CSO: 3650/269

## OUTCOME OF SWEDISH-DANISH DISPUTE WILL INTEREST USSR

Oslo AFTENPOSTEN in Norwegian 9 Aug 83 p 8

[Commentary: "Swedish Lack of Principle"]

[Text] One thing can be considered certain in the small but significant border conflict in the Kattegat between Denmark and Sweden: the Soviet Union is a very interested spectator. And perhaps the Russians have also noticed that the Swedes defend viewpoints toward Denmark which resemble the Russian Baltic negotiations with Sweden. These are viewpoints which Sweden, with great indignation, has rejected.

Countries with several unsolved border problems prefer that special solutions in special areas do not have consequences, or create precedents, for what solutions should be in another area. For example Norway said in the Jan Mayen conflict with Iceland that concessions to the Icelanders were due to entirely special circumstances. Nothing similar would arise in the Jan Mayen conflict with Greenland/Denmark, or in the Barents Sea negotiations with the Soviet Union.

But in any case with Jan Mayen it is difficult to see how Norway can avoid further concessions. Still Norway--as compared with Sweden--did not wind up in the unfortunate situation of claiming two unlikely principles as to how the boundary should be drawn. Therefore Sweden is out on a limb.

The coming negotiations with the Russians may be seen to offer certain difficulties for Sweden in claiming viewpoints which they previously rejected as completely unfair. The compromise solution which will undoubtedly be forced forward in the Kattegat, can consequently have an influence on the final solution in the Baltic. Although a clarification there appears not to be immediately forthcoming. Sweden and the Soviet Union have negotiated over a dividing line in the Baltic since 1969. The last round of negotiations took place in January last year, and new meetings are not planned.

In the Kattegat, as is known, Sweden is not willing to allow the border to be drawn out from Danish Hessel Island. In the Baltic the Russians do not recognize that the border should be drawn out from Gotland. Obviously little Hessel Island, inhabited by a caretaker married couple, and large

Gotland--a Swedish county with 55,000 inhabitants--are not comparable in size. It is, however, the principles. In border negotiations of this type, principles are very important. If one does not adhere to these, the parties easily fall into difficulties, something Sweden has obviously done now.

In the Baltic both Sweden and the Soviet Union believe that the border line should be drawn in accordance with the middle line principle. It is worth mentioning that the Russians in the Barents Sea claim the so-called sector principle against Norway. Both the Soviet Union and Sweden appear to be guided, in different situations, by opportunistic lack of principles.

The Russians want to use the Swedish mainland coast as the point of departure, while the Swedes naturally want to measure the border from Gotland. The difference between the two borders includes a sea area of 13,500 square kilometers. In the last negotiating round last year the Swedes were unexpectedly on the skids, and were willing to give up one-fifth of the disputed area to the Russians. But the proposal was never officially presented because of internal disagreement in the Foreign Ministry. As it worked out, it led to a domestic political conflict which has probably made it politically impossible today to repeat the compromise proposal, even if the government should agree to it.

For the time being Sweden has its hands full with the Kattegat. But even though it is also a question of fishing and oil, there is no doubt that the conflict with the Soviet Union in the Baltic is of much greater importance. Because there vital national security interests are strongly in the picture.

For Sweden it must now be urgent to reach a solution with the Danes which does not increase the problems when they next sit at the negotiating table with the Russians. When that will happen, nobody knows. It is the Soviets' turn to invite, and they are obviously in no hurry. The many submarine violations have not created a favorable negotiating climate between the two countries.

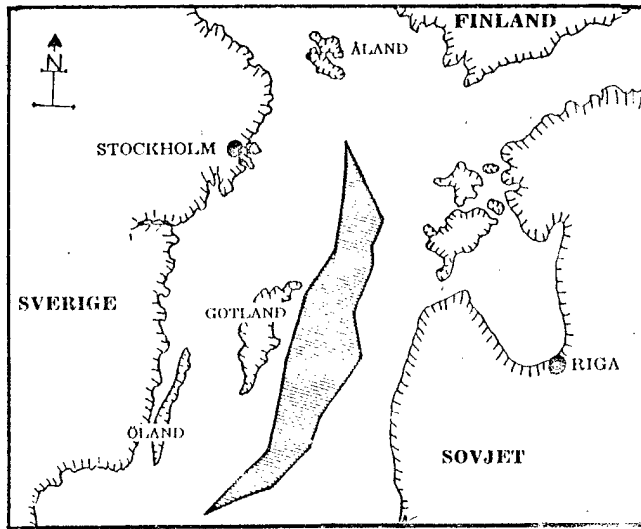

Caption: In the Baltic the Russians want to use the Swedish mainland coast-line as the point of departure, while the Swedes want to measure the boundary from Gotland. The difference is an ocean area of 13,500 square kilometers (shaded area).

9287  
CSO: 3639/158

## WHALING COMMISSION'S DECISION ON QUOTAS TO CREATE PROBLEMS

Oslo AFTENPOSTEN in Norwegian 26 Jul 83 p 2

[Editorial: "Difficult for Norway"]

[Text] The International Whaling Commission, which when it was established in 1946 had 17 member countries, today has 40 participating countries, of which three countries--Norway, the Soviet Union and Japan--continue commercial whaling. At the same time as the number of whaling nations has shriveled more and more, the so-called "protection countries," i.e., countries which want to stop all commercial whaling, have come into a high majority in the commission. This is due not least to the world-embracing anti-whaling campaign being conducted by various animal protection organizations. It has become good politics to take a stand against whaling. This of course makes it difficult for the few remaining whaling nations to win understanding and sympathy for their viewpoints.

Norway's difficulties in this respect were great during the whaling commission's annual meeting in Brighton in the week just past. The commission's scientific committee submitted to the meeting a recommendation that the finback whale quota for the northeast Atlantic Ocean be reduced to 635 animals, or, in other words, a reduction of over 1000 whales as compared with the year before. So large a reduction has obviously serious consequences for the Norwegian whaling industry, and during the commission's meeting Norway tried to bring about a transition arrangement but was met with a cold shoulder from the commission's majority. Norway fought also as long as possible to get a higher finback whale quota for the coming year, and during the 20-hour-long marathon session which ended the commission's talks Norway submitted a suggestion for a quota of 855 animals. But in spite of the fact that the proposal was supported by, among others, Great Britain, France, West Germany and the Soviet Union, the proposal did not get a qualified majority and therefore got nowhere.

During the debate the British representative pointed out that Norway has always played a leading role in working for protecting and safeguarding whale stocks, and that the country has always followed the recommendations of scientists. When Norway now asks for a higher quota it was exclusively in order to make amends for the serious difficulties which the Norwegian whaling industry would encounter because of the big reduction in the quota. However, these arguments did not win sufficient support in the commission.

It is not easy to understand that the commission could not go along with a reasonable transition arrangement for Norway. This so much the more since the commission made other individual concessions for other countries, like Japan, for example. But such in the end was the outcome of the commission's meeting; Norway can now hardly do anything else than to come to terms with the heavily reduced whaling quota.

8985

CSO: 3639/153

## DANES BEGIN OIL SEARCH IN AREA OF KATTEGATT SWEDEN DISPUTES

Stockholm DAGENS NYHETER in Swedish 22 Jul 83 p 4

[Article by Ake Ringberg: "The Danes Are Drilling"]

[Text] We know now that there is oil and natural gas in an area 15 nautical miles west of Kullen, and we will immediately invest 50 million kronor to extract it. A spokesman for the Danish A.P. Moller group said this and disclosed that a rig is already on the way.

The drilling will be in the disputed area in the Kattegatt that Sweden first wants to discuss with the Danes, because it is felt that the borders are unclear. According to the Swedish point of view, the drilling site is in Swedish territorial waters, which the Danes reject.

The Danish search for oil is thus already in full swing. The A.P. Moller group will invest the 50 million kronor through the Danish Underground Consortium (DUC) that has been responsible for obtaining oil and gas in the North Sea.

The new center for the Danish oil and gas explorations will be in Grena, which has already welcomed the oil people as a useful addition to the town's economy. The drilling material is now being shipped from Esbjerg on the west coast of Grena. The oil rig, Marsk Explorer, that was earlier used in the North Sea, will be used in the Kattegatt. The rig has a crew of 80 men, who will be relieved by ship, not by helicopter as in the North Sea.

The announcement that the Danes are ready to start drilling came in a short dispatch last Tuesday from the Danish Ministry of Foreign Affairs. Swedish attention was immediately drawn to the statement that the nationality of the area is disputed. The member of the Swedish Riksdag, Carl Bildt, made a statement that was quoted in Danish newspapers. He said that the Swedish reaction in the border issue with Denmark may have consequences for the Soviet Union's view of the Swedish position in the negotiations about the border between Sweden and the Soviet Union outside Gotland, where there is also a boundary dispute.

If we accept a development where Denmark de facto assumes supremacy over the activities in a disputed area between Sweden and Denmark, the Soviet Union may be tempted to act the same way in the Baltic. Such a development must be avoided, said Carl Bildt, whose statement was diligently quoted in the Danish press.

## INCREASING NUMBER OF NATIONS DOING RESEARCH ON SVALBARD

Oslo AFTENPOSTEN in Norwegian 9 Aug 83 p 52

[Article by Torill Nordeng: "More Than 53 Expeditions This Summer--Svalbard is Center for Polar Research"]

[Text] Svalbard, 1 August. Each year they come back when the sun comes up over the horizon. They are scientists with the world's most advanced scientific measuring instruments, and perhaps an old fashioned ice ax. Out on the glaciers, in the valleys, up in the mountains and out to sea they go, to pick up one more secret from the polar area. Nobody is frightened by the isolation, the biting wind, the fog or a meeting with a hungry polar bear. Some stay through the winter, indoors or in tents. At one of the world's northernmost research stations on land, the Norwegian Polar Institute's research station on New Alesund, 11 people winter over each year.

Up until 22 June this year the governor of Svalbard had noted that 189 scientists in 53 expeditions had conducted their research on land and sea. They came from 20 different nations.

"We do not know how many actually are scientists, and how many are just using the title as a reason for a visit to the Arctic," emphasized expedition chief Thor Siggerud at the Norwegian Polar Institute. He manages the institute's Longyearbyen office in the summertime.

"In any case it is certain that we are not able to completely supervise all who go out on field expeditions. For example the governor's clerk found three Russian scientists out in the field. The consul in Berentsberg has reported that 88 Russian scientists are conducting research up here this summer," said Governor Carl A. Wendt.

One of history's largest, most advanced and most expensive oceanographic research programs is now taking place in the strait between Greenland and Svalbard. It will be completed in 1990, and the natural science knowledge

derived is regarded as very important for both weather warning and exploitation of resources in the northern area. The name MIZEX stands for Marginal Ice Zone Experiment.

#### Computer Age

The research in MIZEX is not easy to see. Our century's computer technology has made its impression also under the polar ice cap. Buoys are placed on the ice and in the water. Current, wind, temperature and position are measured. A satellite receives the signals from the buoys, and the goal is that scientists in the future will be able to sit in an office and systematically follow the movements of the floating ice in relation to the ocean currents. Weather warning according to this system is already taking place. The method is called remote analysis.

Norwegian oceanographer Ola M. Johannessen at the University of Bergen leads the systematic field work. Three ships, several aircraft including Norwegian Orions, and several helicopters are used in the work, and a number of scientists from 10 different countries are participating. During the summer weeks it is expected that 35 million kroner will be expended, of which the United States is paying the most.

#### Fog Around the Next Headland

But the scientists with MIZEX complain that relations between ice, water and air, which we want to know more about, are so unsteady that the work gets difficult. "Patience is a virtue and a necessity when aircraft must stay on the ground for several days because of a low ceiling," said the American professor of geophysics, Bill Campbell. His base is the telemetry station at Tromsø. He runs the operation from there, and receives data from the aircraft participating in the project.

But not all polar research requires such advanced field work. The Japanese geologist Tatsumi has chosen another solution. Well situated on a mountain top, he has employed four assistants collecting stones. At his laboratory in Japan he will systematically investigate the stones he has brought the long distance home. It is not Norwegian granite.

#### Norwegian Polar Institute

The Norwegian Polar Institute's research station in New Alesund is the center of Norwegian arctic research activity all year round. Two scientific assistants and two engineers winter over each year, together with seven people employed in Kings Bay Kullkom. The four are responsible for collecting information from a total of 11 different measuring projects, not all under the Norwegian Polar Institute.

## Reindeer and Eider Duck

Two research programs which have received much attention lately are behavior studies and stock counts of reindeer and eider ducks. Both of these animals have in common that they are numerous. So numerous that this fall permission was given to kill 150 reindeer. It is not yet clear when permission will be given to hunt eider ducks.

## Field Activity

The input of the Norwegian Polar Institute in the Arctic is much greater than the activity at New Alesund. Expedition leader Thor Siggerud is in Longyearbyen and supervises the activities of 73 researchers and assistants at the various field stations. Many people see him as their connecting link with the outside world. "The requirement for a field expedition to succeed is that everybody be well prepared. Nobody can wait to exert himself to the maximum. Roald Amundsen used to say, 'Take no chances and make thorough preparations. If it goes well you are lucky. If it goes the opposite you are unlucky.' And," added Siggerud, "stopping in inaccessible places with extreme weather conditions is the reason why polar research is necessarily so costly. The cost per day of an icebreaker varies from 40,000 to 80,000 kroner depending on the size."

9287

CSO: 3639/158

DELEGATION LEADER: ANTARCTICA CONFERENCE 'SUCCESSFUL'

Oslo AFTENPOSTEN in Norwegian 26 Jul 83 p 7

[Article by John Harbo: "Norwegian Satisfaction with Antarctica Conference"]

[Text] "The International Conference on Antarctica, which was concluded in Bonn before the weekend, was successful, but it will probably be necessary to have a new meeting before there is any final draft of regulations for utilization of the natural resources in the area," says Norway's ambassador to West Germany, Sverre J. Gjellum, who led the Norwegian delegation.

Norway is among the seven countries which have territorial claims in Antarctica. The others are Australia, France, New Zealand, Great Britain, Chile and Argentina. In addition, the USA, Soviet Union, Belgium, Japan, South Africa, Poland and West Germany signed the Antarctica Treaty of 1959. This went into effect in 1961 and can be taken up for revision first in 1991.

The question of territorial claims was therefore not on the agenda in Bonn. Ambassador Gjellum states to AFTENPOSTEN that Norway's claims of sovereignty remain and are not a subject for negotiations.

The main topic at the meeting in Bonn was the development of regulations for future extraction of resources in Antarctica. A draft worked out by New Zealand was under discussion. A number of suggestions for changes were produced during the discussion. Gjellum believes that a new meeting will take place in 6 to 12 months.

It is the large resources which experts believe are concealed under the ice and in the ocean beyond which have led to the fact that attention has been focused on the icy wasteland in the south. The key question at the meeting in Bonn was which institutions are to have decisive authority, which functions they are to have and how decisions are to be made--whether the majority principle is to be used as a basis or whether it shall be required that all concerned parties agree.

Some countries, especially in the Third World, have, besides, begun talking about the fact that the 14 treaty countries should not get to make decisions alone, but that the Antarctica question should be handed over to an international organization like the UN. To what extent Antarctica should be placed under international control, according to Gjellum, did not come up at the conference as a separate topic and he

emphasizes that cooperation hitherto has been unusually successful and should continue.

Although the territorial claims of the seven countries were not on the agenda in Bonn, their position was mentioned, since one of the questions is whether these countries are to have any special rights in the regulations for extraction of natural resources which are now to be drawn up.

8985

CSO: 3639/153

END