

NAVAL POSTGRADUATE SCHOOL

Monterey, California



19980413 042

THESIS

**MODELING A JOINT COMBAT
IDENTIFICATION
NETWORK**

by

Scott A. Davis

December, 1997

Thesis Advisor:
Second Reader:

John Osmundson
Gordon Schacher

Approved for public release; distribution is unlimited.

REPORT DOCUMENTATION PAGE			<i>Form Approved OMB No. 0704-0188</i>	
Public reporting burden for this collection of information is estimated to average 1 hour per response, including the time for reviewing instruction, searching existing data sources, gathering and maintaining the data needed, and completing and reviewing the collection of information. Send comments regarding this burden estimate or any other aspect of this collection of information, including suggestions for reducing this burden, to Washington headquarters Services, Directorate for Information Operations and Reports, 1215 Jefferson Davis Highway, Suite 1204, Arlington, VA 22202-4302, and to the Office of Management and Budget, Paperwork Reduction Project (0704-0188) Washington DC 20503.				
1. AGENCY USE ONLY (Leave blank)		2. REPORT DATE December 1997	3. REPORT TYPE AND DATES COVERED Master's Thesis	
4. TITLE AND SUBTITLE MODELING A JOINT COMBAT IDENTIFICATION NETWORK			5. FUNDING NUMBERS	
6. AUTHOR(S) Davis, Scott A.				
7. PERFORMING ORGANIZATION NAME(S) AND ADDRESS(ES) Naval Postgraduate School Monterey, CA 93943-5000			8. PERFORMING ORGANIZATION REPORT NUMBER	
9. SPONSORING / MONITORING AGENCY NAME(S) AND ADDRESS(ES)			10. SPONSORING / MONITORING AGENCY REPORT NUMBER	
11. SUPPLEMENTARY NOTES The views expressed in this thesis are those of the author and do not reflect the official policy or position of the Department of Defense or the U.S. Government.				
12a. DISTRIBUTION / AVAILABILITY STATEMENT Approved for public release; distribution is unlimited.			12b. DISTRIBUTION CODE	
13. ABSTRACT (<i>maximum 200 words</i>) Today's battlefield is much more heterogeneous than in the past. With the emphasis on joint operations both within the US military and in consort with coalition nations, the need for communications and sharing of tactical information across service and national boundaries has never been greater. A combat identification (CID) network that enables force's positions on the battlefield to be displayed at the appropriate granularity for the various levels of commanders would be a valuable tactical and strategic asset. This thesis explores the possible network architectures and protocols available to implement such a system and determinmes, through modeling and simulation, the optimal design to minimize time performance of the flow of information through the network. Using a realistic scenario as a basis, system engineering principles were used to generate an optimal network architecture from the design parameters chosen. The optimal design was determined to be a network consisting of an Asynchronous Transfer Mode (ATM) access type, asymmetric transmit and receive of messages and network flow control implementation. Additionally, units on the battlefield should be grouped together by type within a region and the highest bandwidth possible should be used.				
14. SUBJECT TERMS Combat Identification, Situational Awareness, Combat ID, Network Modeling			15. NUMBER OF PAGES 68	
			16. PRICE CODE	
17. SECURITY CLASSIFICATION OF REPORT Unclassified	18. SECURITY CLASSIFICATION OF THIS PAGE Unclassified	19. SECURITY CLASSIFICATION OF ABSTRACT Unclassified	20. LIMITATION OF ABSTRACT UL	

NSN 7540-01-280-5500

Standard Form 298 (Rev. 2-89)
Prescribed by ANSI Std. Z39-18

Approved for public release; distribution is unlimited

**MODELING A JOINT COMBAT
IDENTIFICATION NETWORK**

Scott A. Davis
Lieutenant, United States Navy
B.S., Purdue University, 1991

Submitted in partial fulfillment of the
requirements for the degree of

MASTER OF SCIENCE IN SYSTEMS ENGINEERING

from the

**NAVAL POSTGRADUATE SCHOOL
December 1997**

Author: _____



Scott A. Davis

Approved by: _____

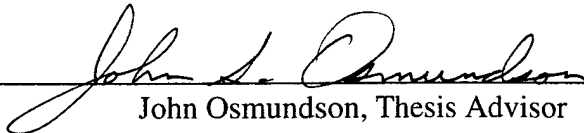

John Osmundson, Thesis Advisor



Gordon Schacher, Second Reader

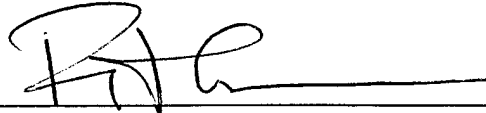

Fred Levien, Chair
Information Warfare Academic Group

ABSTRACT

Today's battlefield is much more heterogeneous than in the past. With the emphasis on joint operations both within the US military and in consort with coalition nations, the need for communications and sharing of tactical information across service and national boundaries has never been greater. A combat identification (CID) network that enables force's positions on the battlefield to be displayed at the appropriate granularity for the various levels of commanders would be a valuable tactical and strategic asset.

This thesis explores the possible network architectures and protocols available to implement such a system and determines, through modeling and simulation, the optimal design to minimize time performance of the flow of information through the network. Using a realistic scenario as a basis, system engineering principles were used to generate an optimal network architecture from the design parameters chosen. The optimal design was determined to be a network consisting of an Asynchronous Transfer Mode (ATM) access type, asymmetric transmit and receive of messages and network flow control implementation. Additionally, units on the battlefield should be grouped together by type within a region and the highest bandwidth possible should be used.

TABLE OF CONTENTS

I. INTRODUCTION	1
II. SCENARIO DEVELOPMENT	3
III. DETERMINATION OF SYSTEM PARAMETERS.....	7
IV. MODELING TECHNIQUES.....	13
V. MODEL DEVELOPMENT	17
VI. MODEL DESCRIPTIONS.....	23
VII. EXPERIMENTAL RESULTS.....	29
VIII. CONCLUSION.....	33
APPENDIX A: SCENARIO DESCRIPTION	35
APPENDIX B: STANDARD ORTHOGONAL ARRAY	37
APPENDIX C: EXPERIMENTAL MODELS	39
LIST OF REFERENCES	55
INITIAL DISTRIBUTION LIST	57

EXECUTIVE SUMMARY

Today's battlefield is much more heterogeneous than in the past. With the emphasis on joint operations both within the US military and in consort with coalition nations, the need for communications and sharing of tactical information across service and national boundaries has never been greater. A combat identification (CID) network that enables force's positions on the battlefield to be displayed at the appropriate granularity for the various levels of commanders would be a valuable tactical and strategic asset.

This thesis explores the possible network architectures and protocols available to implement such a system and determines, through modeling and simulation, the optimal design to minimize time performance of the flow of information through the network. Using a realistic scenario as a basis, system engineering principles were used to generate an optimal network architecture from the design parameters chosen. Determining the optimal design of complex systems such as networks, which have a large number of network paths, messages and message types, can be difficult. Using a method called 'design of experiments' (DOE), a subset of all possible network configurations based on chosen parameters can be modeled. This method provides an optimal design that can then be tested against other system designs to verify the result. An added bonus the DOE method gives is the ability to understand the sensitivity of the design to each parameter. This can be helpful in determining the most cost effective implementations for a system and can also provide a road map for future configuration changes and upgrades.

The optimal design was determined to be a network consisting of an Asynchronous Transfer Mode (ATM) access type, asymmetric transmit and receive of

messages and network flow control implementation. Additionally, units on the battlefield should be grouped together by type within a region and the highest bandwidth possible should be used.

I. INTRODUCTION

Today's battlefield is much more heterogeneous than in the past. With the emphasis on joint operations both within the US military and in concert with coalition nations, the need for communications and sharing of tactical information across service and national boundaries has never been greater. Additionally, the development of long range, precision guided munitions means that the battlefield commander may be hundreds of miles from the FLOT (Forward Line of Troops).

A combat identification (CID) network that enables friendly and enemy positions to be displayed at the appropriate granularity for the various levels of commanders regardless of the source of the information, would be a valuable tactical and strategic asset.

The goal of this thesis is to explore possible network architectures and protocols available for such a CID system and determine, through modeling and simulation, the optimal design to minimize the time of the flow of information through the network. In this analysis, the term 'optimum' is used in the context of the architectural features chosen to model. The use of additional or different parameters could produce a different optimum design.

In the past, the design and implementation of new C³ systems has been performed in a reactive vice proactive manner. Systems were implemented to exploit a new technology or to provide a "quick-fix" to existing systems deemed inadequate or obsolete. In order to effectively design any system, extensive trade studies along with a good understanding of system sensitivities to design parameters and input variables is necessary. The lack of proper system engineering and analysis during a system's

conceptual and early development phases can be traced as the source for many deficiencies in current C³ systems capabilities [Ref. 1].

In addition, the analysis of complex, distributed information systems has proven to be nearly impossible due to the large number of network paths, messages and message types. This difficulty is compounded by the requirement for high bandwidth and time critical message delivery when the network is placed within a combat environment [Ref. 1].

In this thesis project, a graphical technique for representing complex distributed systems is being used to model various network architectures. Simulations are run on the models to obtain performance measures of the system, which are related to various system architectural features. Using the relationship between system performance and system architectural features, system engineering principles applying to the design of networked, distributed systems can be developed.

In conjunction with a "design of experiments" methodology, the optimum system configuration can be tested and the performance sensitivity to each architectural parameter can be identified. This analysis essentially determines which parameters provide "more bang for the buck" if the optimal solution is technologically difficult, too costly or if a nearer-term solution is required. An additional benefit is the ability to incorporate into the system's baseline architecture the proper functionality to facilitate quicker, easier, and less costly upgrades because the critical performance parameters and trade studies have already been performed. Also, any new technologies can be incorporated in the modeling and simulations and compared against the already known optimum to assess if a new optimum system design can be achieved.

II. SCENARIO DEVELOPMENT

In order to accurately test the various experimental designs and provide a sound basis for modeling, it was necessary to generate a realistic battlefield scenario with a diverse collection of forces. The scenario chosen was a small scale amphibious operation consisting of approximately 5,000 friendly forces including fixed and rotary wing aircraft, heavy and light armor, ground troops, artillery units, ships, and landing craft. Figure 2.1 depicts the entire battlefield to include the two major objective areas, a sea port and airfield. Appendix A contains the Initiating Directive and scenario set-up.

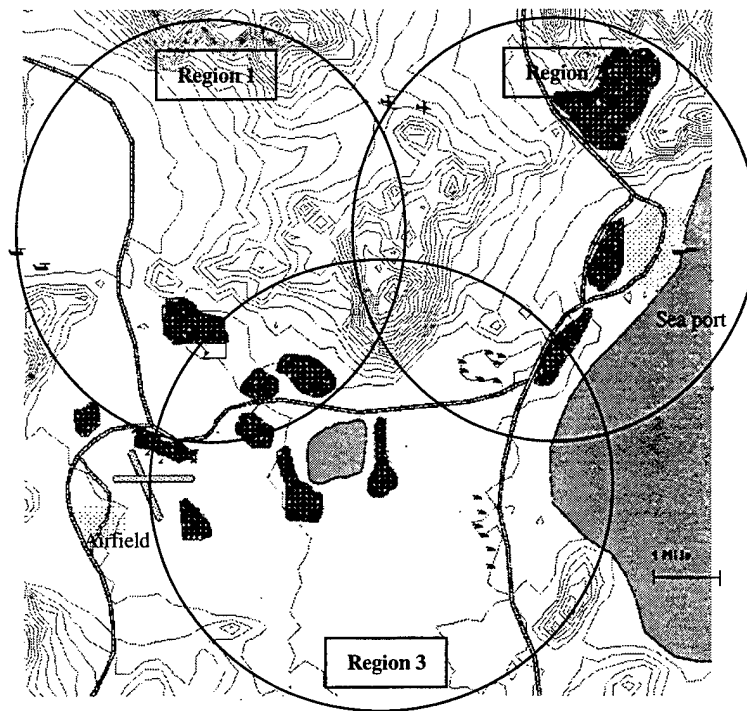

Figure 2.1 – Map of Scenario

The scenario was taken from a combat identification class project conducted in the spring of 1997 by students in the Combat Systems Science and Technology curriculum at the Naval Postgraduate School and was validated by the Joint Service Syndicate at Navy

Tactical Training Group Pacific. The class project involved enemy forces as well, but for the purposes of this study it was assumed that friendly forces were operating in a benign environment with no casualties, equipment failures, or enemy interactions. Additionally, units were grouped into three categories – air, vehicle and troops. These assumptions included the major characteristics of the scenario and placed the emphasis on the specific network architecture and design issues instead of becoming bogged down in scenario details.

The point in the scenario at which the network modeling takes place is after friendly forces have seized the airfield and sea port and are preparing to link up with each other. Enemy forces from the airfield retreated east and lie between the two objective areas. This leads to a red on blue engagement during the link up process.

For network control purposes, the battlefield was divided into three regions representing separate areas of operation (AOA's) as represented by the labeled circles in Figure 2.1. For modeling simplicity, each region was assumed to contain the same combination of forces to include air, ground vehicles, and troops. Table 2.1 gives the regional force breakdown. For the ground units, although 1,500 units are within each region, it was assumed that only one in three units, or one per squad, would be generating a report. Therefore the number of reporting ground units in each region is 500.

Since each region overlaps the other two regions, inter-regional interactions are present. The majority of the action takes place along the intersection between regions one and three where the red on blue engagement takes place. This fact comes into play when routing messages between regions.

Unit Type	Number per region
Air	61
Vehicle	79
Ground	<u>1,500</u>
Total	1,640

Table 2.1 - Regional Troop Breakdown

It was assumed that all the entities within a region would need to know about each other, but they would not necessarily require knowledge of every unit in other regions. For example, if a platoon of tanks in region one was located at the intersection between regions one and three, there would be a higher probability that the platoon would encounter forces from region three than a similar platoon at the upper left hand corner of region one. Table 2.2 shows the message routing assumptions made for this scenario.

Origin Region	Unit Type	Destination Region 1	Destination Region 2	Destination Region 3
1	Air	100%	10%	70%
1	Vehicle	100%	10%	30%
1	Ground	100%	20%	40%
2	Air	70%	100%	70%
2	Vehicle	30%	100%	30%
2	Ground	40%	100%	40%
3	Air	60%	50%	100%
3	Vehicle	20%	70%	100%
3	Ground	30%	20%	100%

Table 2.2 - Interregional Routing Table

The table also takes into consideration the unit type. An aircraft flying from region three to region two would have to know about more units in region two than an infantry platoon due to the aircraft's greater weapon range and speed of travel. Additionally, since the majority of action took place between regions one and three, their interaction

probabilities were higher. Take as an example a tank in region one. It was expected to need information on 100% of units within its own region, 10% of units in region two and 30% of units in region three.

Another assumption was also needed concerning the frequency of reports for the units. For simplicity, all units could have been given the same update rate. This would mean, for example, that infantry and aircraft would report their position at the same interval. Since there is a wide disparity in the speed of each type of unit, either the infantry would be updated at a much faster rate than was needed or the aircraft at a much slower rate. Therefore, it was assumed that faster moving units would need their position updated more frequently. A standard report interval was determined based on the units maximum velocity and the maximum desired distance traveled between updates. Table 2.3 shows the report intervals determined for each unit type.

Unit Type	Max Velocity	Max Distance Between Reports	Report Interval
Aircraft	500 m/s	1,000 m	2 sec
Vehicles	30 m/s	500 m	15 sec
Ground Troops	5 m/s	100 m	20 sec

Table 2.3 - Report Interval Determination

The report interval was determined by dividing the maximum distance between reports by the maximum velocity for each unit type.

The report intervals in conjunction with the scenario provided a sound beginning for the rest of the project. The next chapter is concerned with the development of the system parameters which were used in modeling the various network architectures.

III. DETERMINATION OF SYSTEM PARAMETERS

In order to arrive at a network design that can be considered optimal, all the parameters that describe a network and can influence the time performance of the network must be determined. This determination was made by evaluating existing network architectures and extracting their commonalities and differences. After ensuring there were no duplications between the parameters, the following set was determined:

1. Access type
2. Bandwidth
3. Message broadcast type
4. Unit grouping
5. Flow control

Access type refers to the way in which information is transferred across the network. There are several existing access types in use such as Time Division Multiple Access (TDMA), Code Division Multiple Access (CDMA), Asynchronous Transfer Mode (ATM) and Global System for Mobile Communications (GSM). The types considered for this evaluation were TDMA and ATM. Only these two were chosen for several reasons: First, existing situational awareness (SA) systems such as Situational Awareness Beacon with Reply (SABER) and Enhanced Position Location Reporting System (EPLRS) use TDMA technology [Ref. 2] and provide a good reference point for comparison. Additionally, TDMA is ideally suited for friendly unit reporting which takes place at fixed (but changeable) intervals. Also, TDMA and ATM are at opposite ends of the spectrum in regards to implementation architecture. ATM uses an open architecture which allows for greater flexibility and effective use of bandwidth while TDMA's

performance is constrained by the number of access slots. This dichotomy provides a good test-bed for comparison.

Time Division Multiple Access works exactly as its name suggests. Time slots are allocated to users on the network. Each user takes turns transmitting their information in a round-robin fashion based on a master timer that tells them when to transmit.

Asynchronous Transfer Mode uses a concept called 'bandwidth on demand' to transfer information. This means that a given user requests the appropriate amount of bandwidth, or access time to the network, to transfer the information it has as long as there is no contention for available bandwidth. This way, users with more information or higher priority information do not have to wait until their turn to transmit.

Bandwidth refers to the rate of information transfer on the network and is measured in bits per second (bps). If a network has a requirement to transfer a message size of 1,500 bits in .5 seconds then a bandwidth of $(1,500/.5)$ or 3,000 bps would be needed.

Message broadcast type is concerned with the retransmission of messages to the appropriate users. One type of broadcast would have the messages sent back on the same frequency while another could require a separate frequency. Additionally, either the receiving unit could determine which messages it wanted to receive or the broadcasting unit could select which messages are transmitted.

Unit grouping refers to how units are connected together electronically on the battlefield. Two obvious groupings would be by region - those in close proximity to one another - and by type - aircraft, infantry, etc.

Flow control refers to whether or not there are any special routing or message handling algorithms implemented in the network. Certain messages might be determined to have a higher priority than other messages and are routed first, or the network might have a provision to reduce message loading if the network becomes congested.

Each parameter can also have various levels. For example, flow control can either be implemented or not, bandwidth can be low or high, etc. The levels chosen for the determined parameters are given in Table 3.1 below:

Access Type	Bandwidth	Broadcast Type	Unit Grouping	Flow Control
TDMA	Low	Symmetric	Region	On
ATM	High	Asymmetric	Type	Off
			Region & Type	

Table 3.1 – Network Parameters and Levels

The distinction between access type explores different ways of handling messages. As an example, the cellular phone industry currently uses three different digital access types which are all incompatible – TDMA, CDMA and GSM. They differ in the way they use the frequency space to transmit information. While they each have their advantages and disadvantages, they were all developed separately and have since grabbed their own niche of the cellular phone market. With the rapid growth of the cellular phone industry, the airwaves are used not just to transfer audio, but also computer information, graphics, and video. The cellular phone industry would profit from a similar systems analysis to determine the longevity of the current technology and what to expect in the future.

Two levels of bandwidth were chosen because the design of experiments methodology requires the use of discrete rather than continuous variables. Low and high

bandwidth correspond to 9,600 bps and 28,800 bps respectively. The low bandwidth is representative of the data rate for a current situational awareness system, SABER [Ref. 2] while the high bandwidth is representative of commercial systems. The important consideration regarding bandwidth is not the actual transfer rate, but the relative affect it has on message delay time. An increase in bandwidth results in a decrease in delay time because more information is transmitted in a given time interval. Therefore, 28,800 bps is expected to perform better than 9,600 bps, but the issue is what is the relative performance gain per dollar for bandwidth increase when compared to flow control or broadcast type. Additionally, at some maximum value of bandwidth, other factors such as propagation delay and processing delay dominate. For example, if the round trip propagation delay is calculated to be 5 milliseconds, then a 500 bit message transferred at 100,000 bps would correspond to the same delay time ($500 / 100,000$). Therefore, in choosing bandwidths for this study, it was only important that the relative performance of the different bandwidths be compared. If a low bandwidth whose poor performance inhibited measuring the effects of the other parameters or a high bandwidth whose performance was masked by the propagation delay were used, the results of the study would not be able to be interpreted clearly.

A symmetric broadcast type means the transmitted and received data share the same network pathways. For example, on a TDMA network, there must be an access time slot for the received messages as well as those being transmitted. Asymmetric implies the opposite. The received messages are rebroadcast by some other method to the units that require them. This cuts down on the amount of message traffic on the network, but requires some modifications such as an additional receiver to accommodate this.

Unit grouping has two major levels, region and type, but can also be made up of a combination of the two, i.e. type within region. This grouping assumes that not only will units within a given region need to know about each other more frequently, but also units of the same type within that region will interact more frequently.

Finally, flow control, for the purpose of this study, is either implemented or not. Either there are some intelligent message routing algorithms or the messages are sent and received regardless of their priority or network loading. The method of flow control used in this project is discussed in Chapter V.

IV. MODELING TECHNIQUES

When all the parameters and levels have been determined, there must be a method to determine their effects. One method would be to model every combination of parameter and level and pick the one that gave the best results. Unfortunately, the number of models that would have to be developed would be 48 ($2^4 \cdot 3^1$). Instead, one can use statistical process control (SPC) and more specifically, statistical design of experiments (DOE) to model only a subset of the total combinations and find the optimum design. The method of SPC used in this project is called The Taguchi Method and was developed in the 1940's by Dr. Genichi Taguchi [Ref. 3]. Dr. Taguchi's methods were developed to optimize the process of engineering experimentation in an effort to design quality into a product instead of inspecting the product for quality after the fact. Although this project does not involve the manufacturing or production of a product, there is an optimum level of performance that a network can achieve given a finite set of design parameters. This is analogous to designing quality into, or obtaining maximum performance from, the network.

Dr. Taguchi's methods involve setting up specially constructed Tables known as "orthogonal arrays" (OAs) of the various parameters and levels to create a subset of experiments to run [Ref. 3]. Taguchi constructed a special set of OAs to be used for various experimental situations with varying parameters and levels. From these OAs, an array for almost any combination of parameters and levels can be constructed. The determination of the OA for this analysis is presented below.

After determining the number of parameters and the levels for each parameter, the next step is the construction of the orthogonal array. To choose the correct size of OA, one must first determine the number of degrees of freedom for the experiment. This will define the minimum number of columns required and thus the minimum OA size.

The total number of degrees of freedom (DOF) is determined in the following manner:

1. # DOF for a parameter = # levels in the parameter - 1
2. # DOF for the system = total # DOF for each parameter

For this experiment there were four 2 level parameters and one 3 level parameter.

Therefore, the total # DOF = $4*1 + 1*2 = 6$ DOF. This means that the appropriate OA cannot have less than 6 DOF. The L_8 array has 7 DOF [Ref. 3], and therefore is suitable to use. (See Appendix B for the standard L_8 array).

Chapter V of Ref. 3 thoroughly explains the development of experimental OA's from standard ones. To create the OA for this project, columns 1, 2 and 3 were combined to create a three level column for transmit type and columns four through seven were assigned to access type, bandwidth, receive type and flow control respectively. The resulting OA is shown in Table 4.1 below.

Trial #	Access Type	Bandwidth	Receive Type	Transmit Type	Flow Control
1	TDMA	Low	Asymmetric	Region	On
2	ATM	High	Symmetric	Region	Off
3	TDMA	Low	Symmetric	Type	Off
4	ATM	High	Asymmetric	Type	On
5	TDMA	High	Asymmetric	Combo	Off
6	ATM	Low	Symmetric	Combo	On
7	TDMA	High	Symmetric	<i>Region</i>	On
8	ATM	Low	Asymmetric	<i>Region</i>	Off

Table 4.1 - Orthogonal Array

The italicized entries in the transmit type column represent the fact that the column was created as a four level, but only three were required. Therefore the fourth level was filled in with one of the other three levels.

V. MODEL DEVELOPMENT

After determining the five parameters and levels to be evaluated and constructing the appropriate orthogonal array, the requisite models to be evaluated were developed. An object-oriented modeling program developed by Imagine That, Inc. called **Extend**[®] [Ref. 4] was used to simulate the eight network configurations. **Extend**[®] is an easy-to-use, graphical simulation program which allows the user to model complex continuous and discrete systems while varying performance parameters to arrive at an optimal solution. The parameters varied in this project were outlined in Chapter III.

The first parameter to be modeled was access type. The two variations considered in this analysis were Asynchronous Transfer Mode (ATM) and Time Division Multiple Access (TDMA). For all models, objects, called program blocks in Extend, represent friendly units. Program blocks allow the repetition of information at a set interval and are used to simulate all the reports of a specific unit type within a region. For example, if there were 100 aircraft in a region and the aircraft report rate was determined to be every two seconds, the repeat interval would be .02 seconds ($2/100$). Since the friendly units desired reporting interval is known, this works well.

In the ATM model, each report is placed on the network as it is generated. In the TDMA model, a clock timer is used to determine when each unit report is transmitted onto the network. For example, if a three port TDMA network is used at 9,600 bps, a 500 bit message would require ($500/9,600$) or .0521 seconds to be transmitted. Therefore, the clock would cycle between each port at an interval of .0521 seconds for a total net cycle time of .1563 seconds. In either case, the reports are then collected in a queue and

combined into a data stream for transmission through the network. If flow control is implemented, the reports will be collected in a priority queue before being rebroadcast. This will ensure that messages marked as critical or urgent receive priority on the network.

The second parameter was bandwidth. In order to model bandwidth discretely, two levels were chosen and arbitrarily labeled low and high. For this set of experiments, these labels corresponded to values of 9,600 and 28,800 bits per second (bps) respectively. The bandwidth has an affect on the rate information can be transmitted on the network. This rate can be characterized as a delay which is based on the message size and bandwidth (bps): $Delay = \frac{message\ size}{bandwidth}$. The message size chosen for each report was 500 bits, therefore, as an example, the delay due to bandwidth at 9,600 bps is .0521 seconds.

The third parameter was flow control. Flow control is a technique used to intelligently route and categorize messages based on a previously determined algorithm or matrix. In these experiments the presence of flow control was simulated by assigning priorities to reports from different unit types and then sorting on these priorities for routing purposes. The priorities were chosen based on the reporting unit's speed - the lower the speed, the lower the priority. Table 5.1 lists the priorities assigned to each unit type.

The messages were sorted by priority by means of a priority queue placed at the appropriate levels in the network hierarchy. In the cases where flow control was not implemented, the queues were simple first-in-first-out (FIFO) queues.

Unit Type	Priority
Air	1
Vehicle	2
Ground	3

Table 5.1 - Reporting Unit Priorities

The fourth parameter was broadcast type. Broadcast type refers to the manner in which the processed reports are disseminated to the appropriate units. Two basic mechanisms exist for distributing the messages to the receiving units. The first is by broadcasting the message via a separate frequency to all units and the second is by sending the message back through the network from which it came. These techniques are referred to as asymmetric and symmetric communications respectively. There are advantages and disadvantages to both techniques. Broadcasting the messages implies using a different frequency from the one used to transmit the initial message reports which means using a separate receiver. Additionally, each recipient must know which messages are relevant and which to discard or the messages are chosen for the receiving unit by the broadcast station. The advantage of broadcasting is that the messages do not have to be included in the frequency band being used for up-link and the only delay involved is that due to propagation from the transmitting source(s) to the receiving unit(s). Using symmetric communications means that only one transmitter/receiver (transceiver) has to be used since they are on the same frequency, but there is the potential for increased delay due to the increase in message traffic.

The delay induced by propagation was calculated to be approximately 500ms round trip (based on a broadcast satellite at an altitude of 500nm) and is modeled as an

activity delay block. Therefore, once a message is generated, subjected to bandwidth delay, routed and subjected to propagation delay, it is assumed to have reached its destination and no further simulating is required. In the symmetric case, however, the messages follow the same path but then they must also be routed to the appropriate destinations.

The fifth parameter is unit grouping. Three levels of grouping were considered - type, region and a combination of both type and region. Grouping by type assumes similar units will need to know about and communicate with each other on a more frequent basis than dissimilar units. Regional grouping assumes that units in close proximity to each other will communicate most frequently. Finally, a combination of region and type implies that within a given smaller region, units of the same type will communicate most frequently while other units in the region will also communicate most often within region than without. Although grouping by type within region looks similar to grouping by region, it differs in the way messages are routed to the end users. Figure 5.1 graphically represents the three different groupings.

Combining all five parameters and their various levels into an orthogonal array resulted in eight separate case studies to be developed, run and compared to determine the optimum configuration.

Since this project's goal was to develop a top-level network design, many important but secondary design considerations were not modeled. These issues would best be considered in a more detailed network model after the initial network architecture is proven. The issues include but are not limited to: enemy reports, encryption, security,

error correction/retransmission, reliability, addition or subtraction of units into the network, processing time, and dynamic/more complex prioritization techniques.

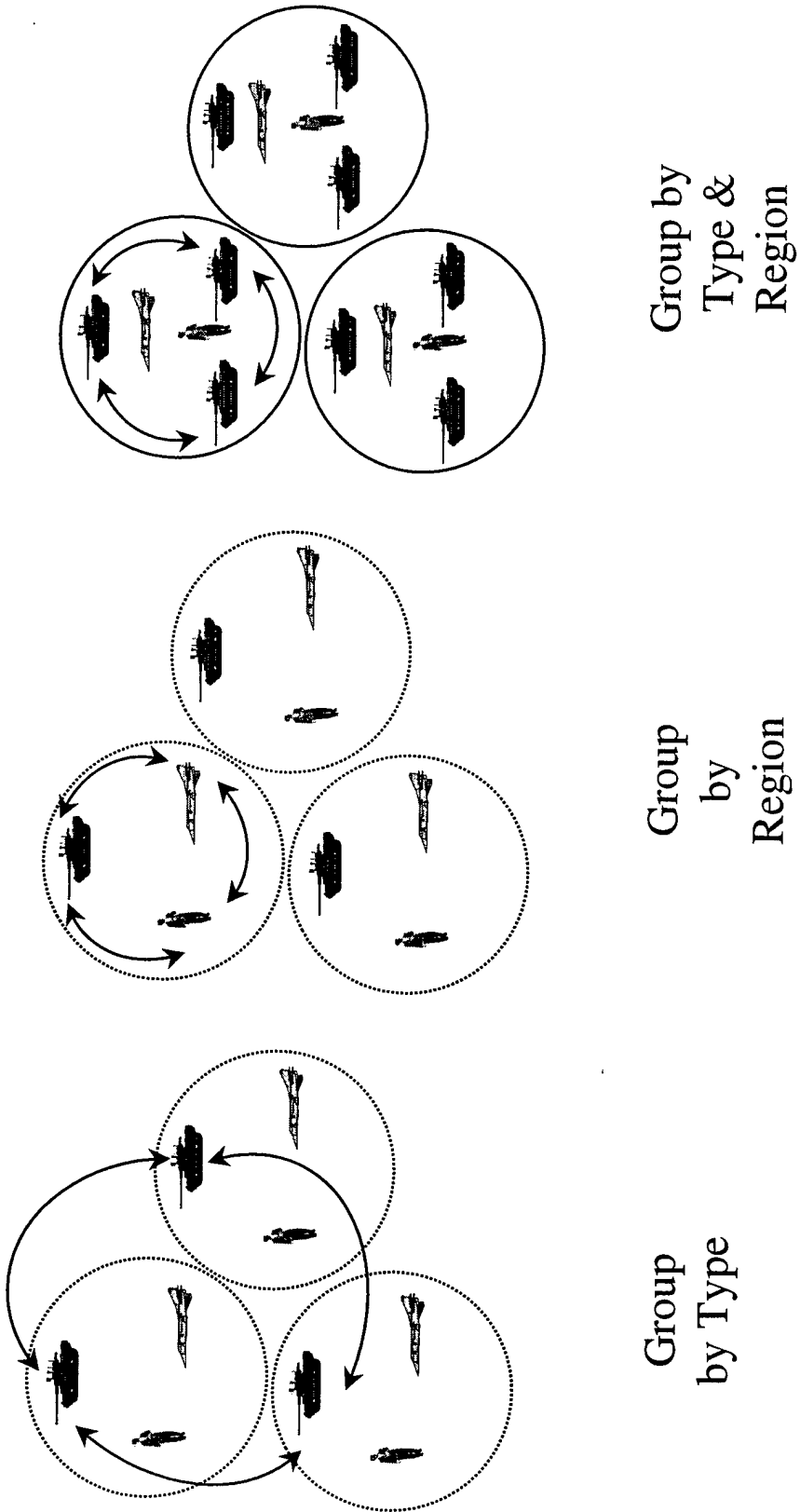

Figure 5.1 - Battlefield Groupings

VI. MODEL DESCRIPTIONS

The eight network models developed for this study all follow, more or less, the general layout shown in Figure 6.1 and are presented in Appendix C. Any variation from Figure 6.1 will be discussed in this chapter. First, the units were either grouped by region, by type or by type within region. Figure 6.1 shows the messages grouped by region. Messages were generated by a source called a program block and subjected to a bandwidth delay of either 9,600 bps or 28,800 bps. The program block allows for a given set of parameters to be repeated over a desired time interval. In this case, the program generated one 500 bit message at an interval representative of the number of units in the region. For example, Table 2.1 identifies 61 aircraft per region and Table 2.3 states that each aircraft has a report interval of 2 seconds. Therefore, the report rate is equal to 30.5 reports per second ($61/2$). The reporting frequency then becomes the inverse of the report rate or .0328 seconds. This means that an air program block generates one 500 bit message every .0328 seconds. The program block is also where the priorities in Table 5.1 are assigned. Additionally, the time a message was generated is also measured at this point for use in calculating the message delay.

The messages were then given a 'routing code' in the regional routing block. This routing code identified the source region of the message and implemented the routing Table presented in Table 2.2. Then, depending on what access type was being modeled, the messages were either combined into a single stream (ATM) or entered a TDMA block which operates as described in Chapter V. Prior to leaving the region, the messages had

to be sorted in the message router block and sent through a priority queue or regular queue depending on if flow control was being implemented.

The second message router block was used to send the proper number of messages to each region. Each message entering the regional routing block could be assigned any or all of three attributes: destination1, destination2 and destination3. The attributes correspond to the destination regions for the message and were assigned based on Table 2.2. For example, an aircraft from region one would have 100 percent of its generated messages assigned the attribute destination1, 10 percent assigned destination2 and 70 percent assigned destination3. Because of this, some messages were required to be sent to one, two, or all three regions. To model this, the messages were cloned based on which attributes they were assigned and recombined so that each cloned message only had one destination attribute. To illustrate further, if 100 messages were generated by the above aircraft, then a total of 180 (100 +10 +70) separate messages were created with only 80 (180 –100) exiting the region. The messages that required internal distribution were removed from the network and re-broadcast within the region. The rest of the messages left the region and were combined with messages from the other two regions. Again, depending on which access type was used, the messages were either directly combined (ATM) or combined after going through another TDMA block. After leaving their respective regions, the messages were combined in a stream, prioritized if required and subjected to the five millisecond two-way propagation delay. Finally, depending on which broadcast type was being modeled, the messages were either sent to an exit block, which assumed they had reached their intended receivers, or were rebroadcast back to the receiving units.

If the asymmetric broadcast type was being modeled, then the message was assumed to have reached the recipient and the delay is measured (trial #1). If the model is of a symmetric broadcast type, the messages are then sorted by destination region in the symmetric broadcast block and sent to the corresponding region (trial #2). For the symmetric broadcast, if the access type is ATM, the messages are collected in a queue at the destination region, the delay is measured and plotted and the messages are discarded (trial #2). If the access type is TDMA, the messages must come into the region via a TDMA access port, then the delay can be measured and plotted and the messages discarded (trial #7).

If the broadcast was symmetric and the units were grouped by type as in trial #3, the messages could not be sent back to a specific region. Instead, they were all sent to each TDMA type network and the delays for each type were measured and averaged together to give an overall representative delay.

Trial #6 was similar to trial #3 except that the access type was ATM. This meant that the messages did not have to go through a TDMA block so the delay could be measured from message creation until the message was sent to the appropriate TDMA block.

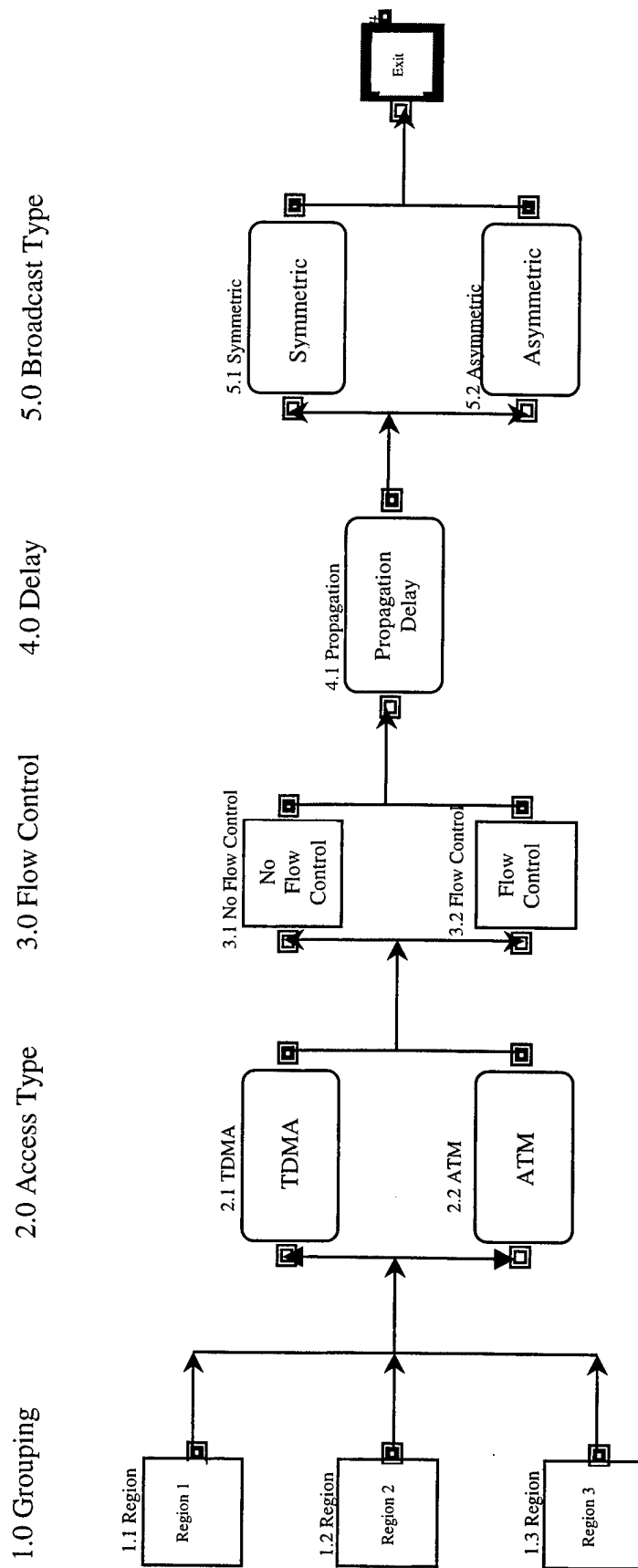

Figure 6.1a - Level 1 of Model Flow Chart

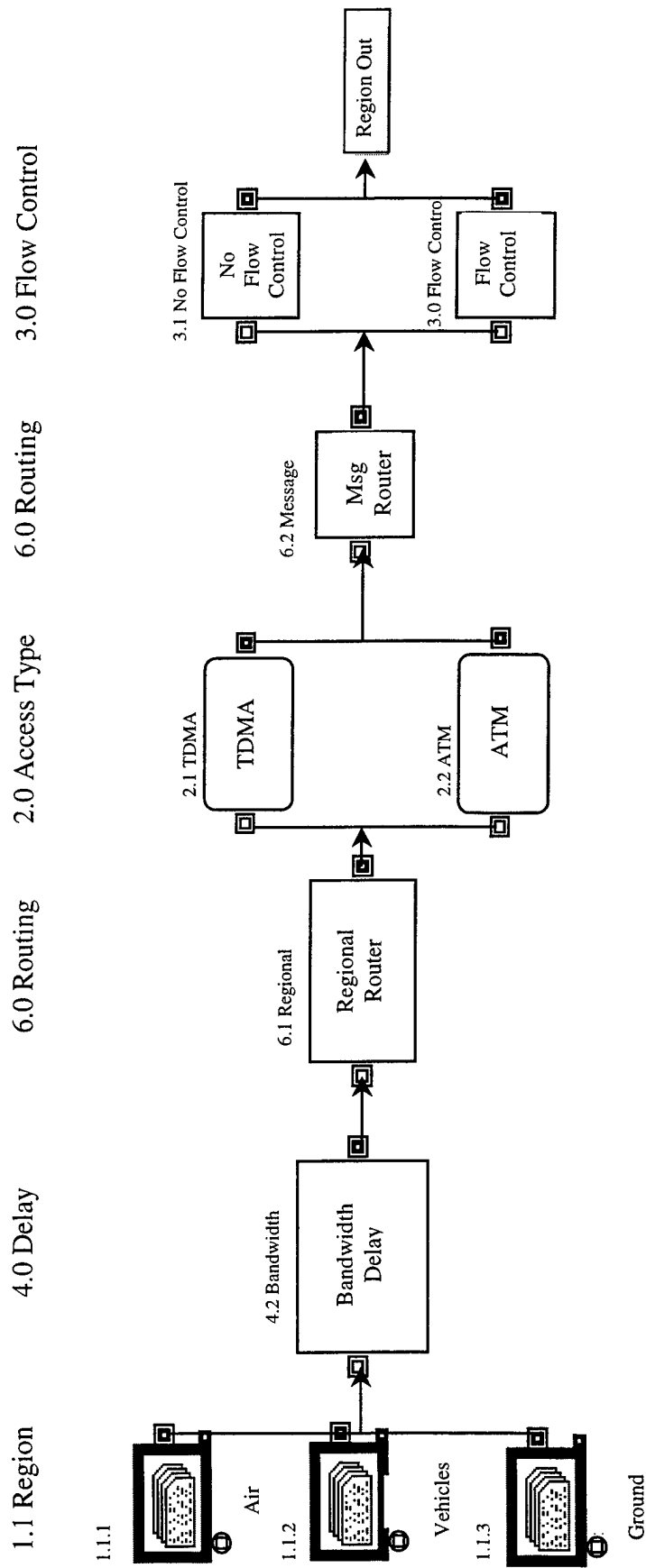

Figure 6.1b - Level 2 of Model Flow Chart

VII. EXPERIMENTAL RESULTS

The goal of this analysis was to discover the optimum network architecture for the set of parameters modeled that would minimize the message delay of a combat ID reporting system. Delay can be characterized by several measures: The maximum time required for a message to get from origin to destination, the average time required for a message to get from origin to destination, and the initial delay incurred by a message on the network. This thesis was only concerned with the minimization of delay and not specific values. After the optimum network architecture is discovered, desired maximum allowable values can be placed on delay and the optimum implementation of the network can be evaluated.

In this analysis, all three types of delay were initially considered. Table 7.1 presents the results from the eight trail runs. Examining the initial message delay revealed a very small delay with relatively small variations in values. This was thought to be caused by a lack of initial network loading resulting in an initial steady state condition not being reached.

Trial	Initial Delay (sec)	Average Delay (sec)	Max Delay (sec)	Broadcast Type
1	.18	9.28	18.56	Asymmetric
2	.02	.02	.03	Symmetric
3	.37	21.77	43.08	Symmetric
4	.02	.03	.05	Asymmetric
5	.04	.07	.10	Asymmetric
6	.06	.06	.07	Asymmetric
7	.05	.05	.08	Symmetric
8	.08	9.46	18.51	Symmetric
Optimum	.03	.03	.04	Asymmetric

Table 7.1 - Delay Measurements for the Eight Trials

In other words, the network had zero messages on it, therefore the delay was not representative of the various architectures. Therefore, initial message delay was not considered. The variations in average and maximum message delay, however, were significant. Examining Table 7.1 shows both delays significantly lower for those trials with asymmetric access type (trials with two exceptions: trials two and four. The reason for this anomaly is discussed below.

Using **The Taguchi Method** of SPC to plot the results of the trials reveals the optimum network configuration shown in Figure 7.1. The average and maximum delay produced similar results therefore only the average delay is plotted. Using the evaluation 'smaller is better', the optimum levels for each parameter are bolded in Figure 7.1 and the final optimum configuration is presented in Table 7.2.

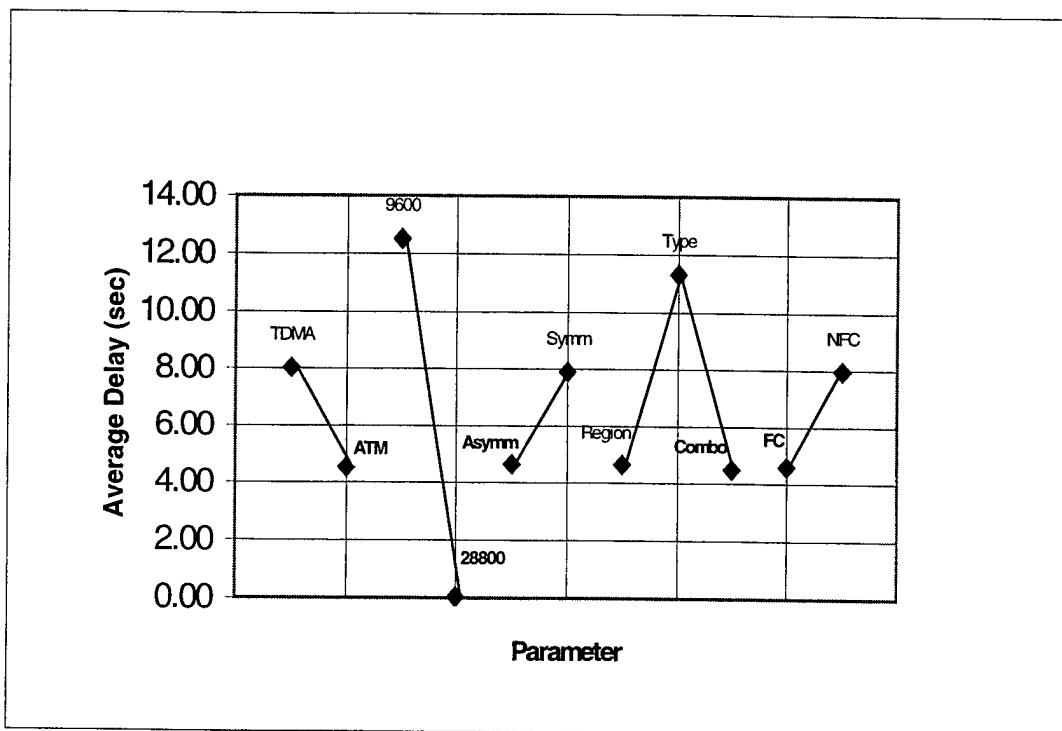

Figure 7.1 - Average Delay Optimization Plot

The plot revealed that an ATM access type with a high bandwidth, asymmetric broadcast, flow control and units grouped by type within region should be optimal. When the optimum configuration was run, the average and maximum delays were expected to be less than all other eight trials. This was not the case. The optimum configuration produced delays that were low, but not the lowest. Trials 2 and 4 had lower average and maximum delays. Examining the similarities and differences between the configurations revealed that both trials and the optimum had the same access type (ATM) and bandwidth (28,800 bps).

Access Type	Bandwidth	Broadcast Type	Unit Grouping	Flow Control
ATM	High	Asymmetric	Type & Region	On

Table 7.2 - Optimum Network Configuration

Since it is generally accepted that an increase in bandwidth allows faster information flow, it is possible that 28,800 bps had a larger affect on minimizing delay than the other four parameters. To test this theory, all three models were re-run with a bandwidth of 9,600 bps. The results are presented in Table 7.3 and clearly show that the optimum configuration produces the lowest average and maximum delay.

Trial	Average Delay (sec)	Maximum Delay (sec)
2	9.55	18.36
3	9.43	18.54
Optimum	.064	.077

Table 7.3 - Average and Maximum Delay at 9,600 bps

Examining Figure 7.1 also provides some qualitative results as to the effect of each parameter on the average delay time. From the figure, bandwidth plays the largest role in reducing the delay time followed by access type, broadcast type, and flow control

with roughly even effects. There is a large difference between units grouped by type and grouped by region which is represented by regional and combination grouping (which contains regional grouping) having much lower delays. But between regional grouping and type within region grouping, the difference is much less but still measurable. The small difference in these two delays could be related to the scale of the scenario.

Grouping by region could be considered a small sub-set of grouping by type within region if there were only one type of unit within a given region. This would result in the delays being exactly the same. However, as the number of regions is increased along with the number of each unit type within a region, this small delay disparity would grow. One could argue then that for smaller conflicts or a smaller number of regions, it would not matter whether the units were grouped by type within region or only by region.

VIII. CONCLUSION

The goal of this thesis was to explore the possible network architectures and protocols available for use in a combat identification system and determine, through modeling and simulation, the optimal design to minimize the time required of the flow of information through the network. Through the use of systems engineering principles, design of experiment methods, and a graphical modeling tool, this goal was achieved. When attempting to design a complex system it is often difficult to identify the important parameters and recognize how to arrive at an optimal solution. It is only after numerous design iterations and trial and error that a 'better' system is produced. But is it optimal? System engineering coupled with SPC provides a road map to the optimal systems design solution. Many times the reason why a specific design is chosen is not fully understood. A realistic scenario provides important top level system design requirements and gives a basis for evaluating the effectiveness and validity of system parametric choices. Additionally, meaningful system trade-offs provide the answer to why a give design choice is made, help identify the most cost effective parameters for improving system performance and provide achievable milestones towards implementing the optimal design.

The results presented here should be followed by a cost benefit analysis for each parameter. This would help determine which parameter would provide the largest decrease in delay for the cost. For example, if an existing system could have software modifications added to implement flow control to decrease the delay to acceptable levels, this would be much less expensive than upgrading equipment to handle higher bandwidth.

Additionally, the optimal model should be verified on a proven network simulation program such as COMNET or OPNET. Although the results of this thesis are sound, they only provide relative measures of performance. Modeling the optimal network on COMNET or OPNET would provide a realistic measure of potential network performance as well as being an alternate method of verification.

One of the goals of this thesis was to explore a new method of evaluating complex systems such as networks to determine the optimum system configuration by applying system engineering principles. By achieving the optimal design without having to run a large number of experiments or by trial and error, it could be concluded that the design method was successful. As an added benefit, the results also provide a functional baseline for system upgrades and modifications.

Using a process similar to the one performed in this thesis it is possible to provide a road map with the system's optimal design as the final destination. If this process is performed in the concept development phase of a system, it would become easier to plan upgrades throughout the life of the system, especially taking into account life-cycle cost.

APPENDIX A. SCENARIO DESCRIPTION

Following is part of the Initiating Directive and Order of Battle created for the Combat Systems Science & Technology class project as mentioned in Chapter II.

I. Situation:

A. After an initial invasion of Red forces into the country of Blue, Red gains have stabilized. Blue has requested NATO help remove Red from its territory. The U.S. is planning to take the lead. Red has left its flanks open as their initial intentions were to have conquered Blue quickly leading to political negotiations. Counter-offensive NATO forces were not expected. In the northern flank of the country of Blue just south of the border, an opportunity to gain minimally opposed force entry is upon us.

B. Enemy forces in the area are comprised of several reserve motorized Battalions from the country of Red.

C. CTF 20 will stand up with task organization according to the annex on assignment of forces.

II. Mission: CTF 20 will conduct a surprise amphibious assault in the vicinity of the port city and airfield in order to secure them for follow on forces.

III. Operations:

A. Phases: (I) Amphibious task force to arrive NLT 1 Jan, 2005.

(II) Conduct amphibious assault IAW mission NLT 2 Jan, 2005.

(III) Introduction of follow on forces.

B. ATF objective areas include the port and the airfield.

APPENDIX B. STANDARD ORTHOGONAL ARRAY

The orthogonal array below was used to generate the combination of parameters and levels in the eight experimental models shown in Table 4.1. A description of how this array was converted into Table 4.1 is also given in Chapter IV.

Columns	1	2	3	4	5	6	7
Trials							
1	1	1	1	1	1	1	1
2	1	1	1	2	2	2	2
3	1	2	2	1	1	2	2
4	1	2	2	2	2	1	1
5	2	1	2	1	2	1	2
6	2	1	2	2	1	2	1
7	2	2	1	1	2	2	1
8	2	2	1	2	1	1	2

Table A. – $L_8(2^7)$ Orthogonal Array

Columns are design parameters. In this standard orthogonal array, each design parameter has two levels indicated by values one and two. Variations of each of these levels for the eight trials are shown as entries in the table.

APPENDIX C. EXPERIMENTAL MODELS

Following are printouts of the eight models used in this study. Additionally, hierarchical blocks were used in the models to represent functions used multiple times within a model or were common between models. The hierarchical blocks along with their functional description are also provided.

	Description	Comments	Page #
Model #1		TDMA, 9600bps, Asymmetric, Regional grouping, Flow control	
	Layer 1	Figure C.1a; Top layer of model 1	40
	Layer 2	Figure C.1b; Region 1 (regions 2 & 3 are identical)	40
	Bandwidth delay	Figure C.1c; Used in all 8 models	41
	Regional routing	Figure C.1d; Used in all 8 models	41
	TDMA	Figure C.1e	42
	Clock timer	Figure C.1f	42
	Message routing	Figure C.1g	43
	Delay plotter	Figure C.1h	43
Model #2		ATM, 28800bps, Symmetric, Regional grouping, No flow control	
	Layer 1	Figure C.2a; Top layer of model 2	44
	Layer 2	Figure C.2b; Region 1 (regions 2 & 3 are identical)	44
	Symmetric rebroadcast	Figure C.2c; Used for Regional grouping	45
Model #3		TDMA, 9600bps, Symmetric, Type grouping, No flow control	
	Layer 1	Figure C.3a; Top layer of model 3	46
	Layer 2	Figure C.3b; Ground block (air & vehicle similar)	46
Model #4		ATM, 28800bps, Asymmetric, Type grouping, Flow control	
	Layer 1	Figure C.4a; Top layer of model 4	47
	Layer 2	Figure C.4b; Air block (ground & vehicle similar)	47

Table C.1 – Experimental Model Descriptions

	Description	Comments	Page #
Model #5	Layer 1	TDMA, 28800bps, Asymmetric, Type & Region grouping, No flow control Figure C.5a; Top layer of model 5	48
	Layer 2	Figure C.5b; Air block (ground & vehicle similar)	48
Model #6	Layer 1	ATM, 9600bps, Symmetric, Type & Region grouping, Flow control Figure C.6a; Top layer of model 6	49
	Layer 2	Figure C.6b; Air block (ground & vehicle similar)	49
	Symmetric rebroadcast	Figure C.6c; Used for Type & regional grouping	50
	Source region determination	Figure C.6d Used for Type & regional grouping	50
Model #7	Layer 1	TDMA, 28800bps, Symmetric, Regional grouping, Flow control Figure C.7a; Top level of model 7	51
	Layer 2	Figure C.7b; Region 1 (regions 2 & 3 similar)	51
Model #8	Layer 1	ATM, 9600bps, Asymmetric, Regional grouping, No flow control Figure C.8a; Top layer of model 8	52
	Layer 2	Figure C.8b; Region 1 (regions 2 & 3 similar)	52
Optimum	Layer 1	ATM, 28800bps, Asymmetric, Type & Regional grouping, Flow control Figure C.9a; Top layer of optimum model	53
	Layer 2	Figure C.9b; Air block (ground & vehicle similar)	53

Table C.1 – Experimental Model Descriptions cont.



Model #1

Access Type: TDMA
 Bandwidth: 9600 bps
 Receive Type: Asymmetric
 Transmit Type: Regional
 Flow Control: On

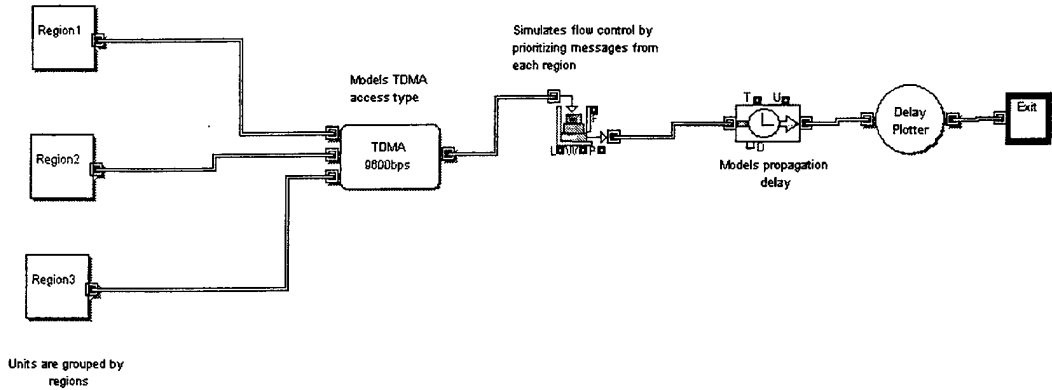

Figure C.1a – Top Layer of Model #1

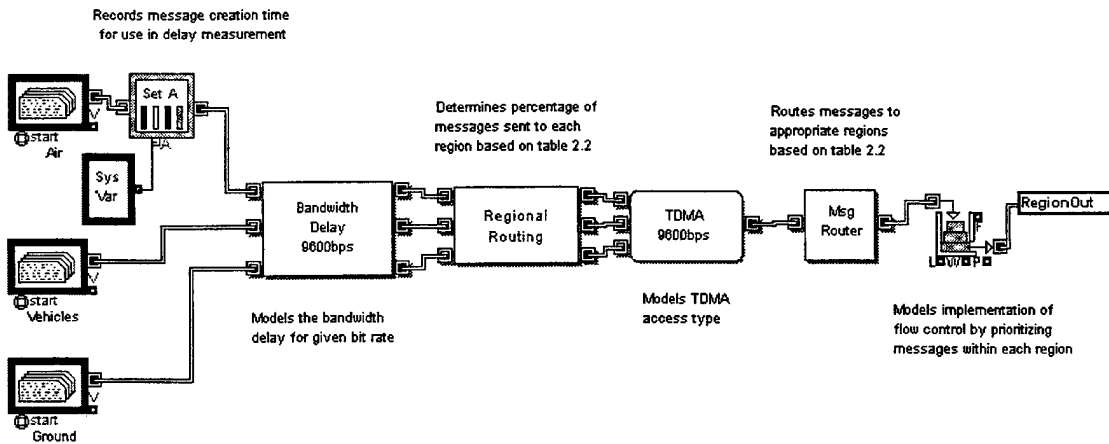
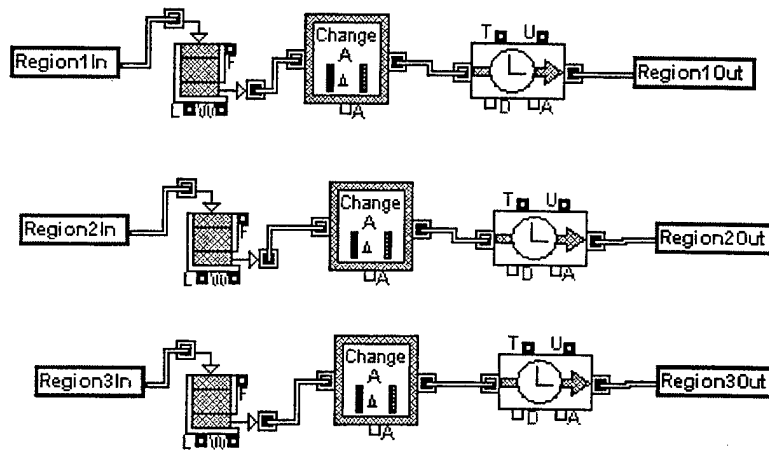
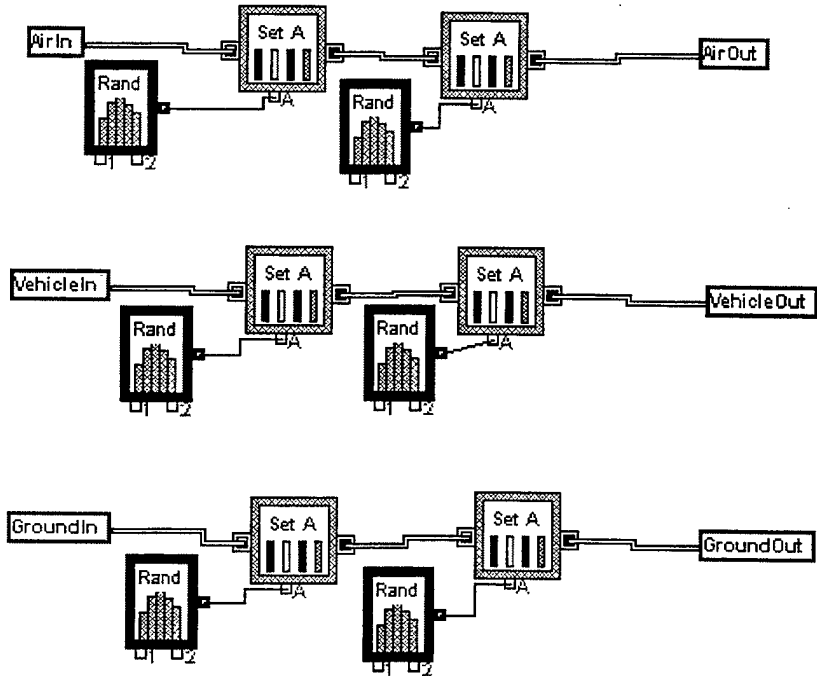

Figure C.1b – Region 1 of Model #1



Divides the message size by the bandwidth to produce a bandwidth delay in seconds

Figure C.1c – Bandwidth Delay Block



Determines message routing based on Table 2.2

Figure C.1d – Regional Routing Block

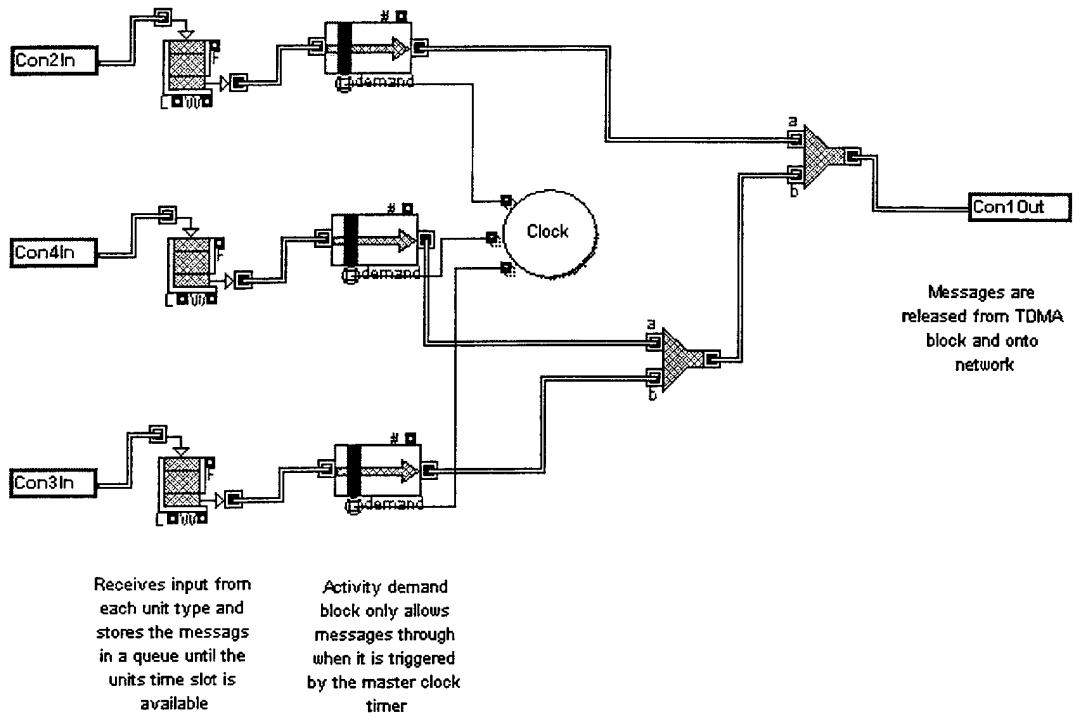

Figure C.1e – TDMA Block

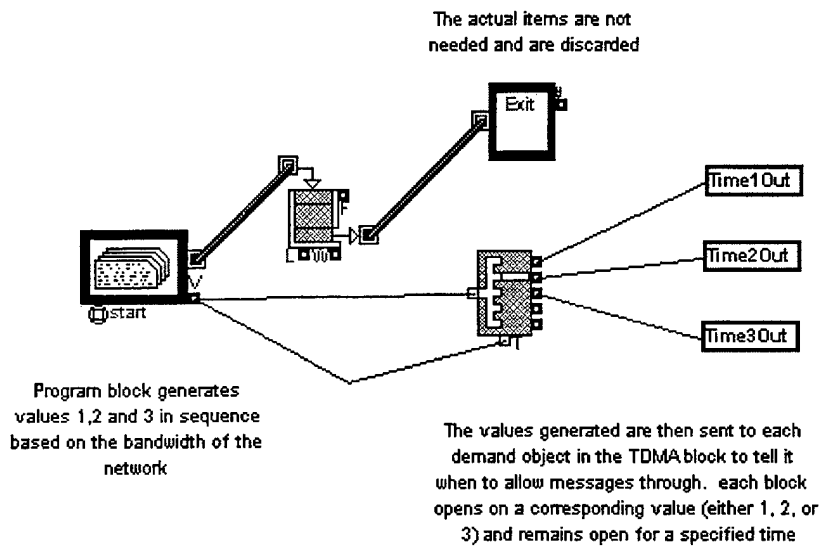

Figure C.1f – Clock Timer Block

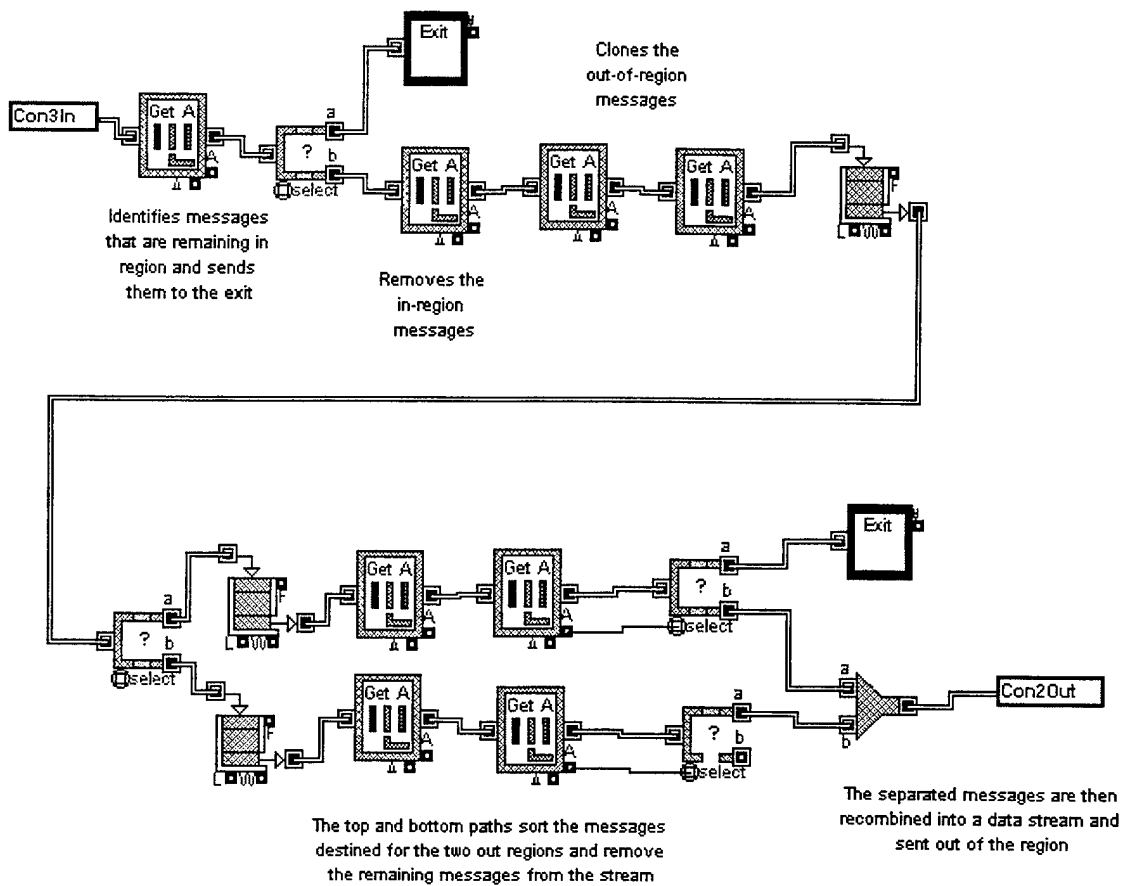

Figure C.1g – Message Routing Block

The message generation time read and subtracted from the current message time to obtain the message delay. The individual message delay along with the mean message delay are then plotted

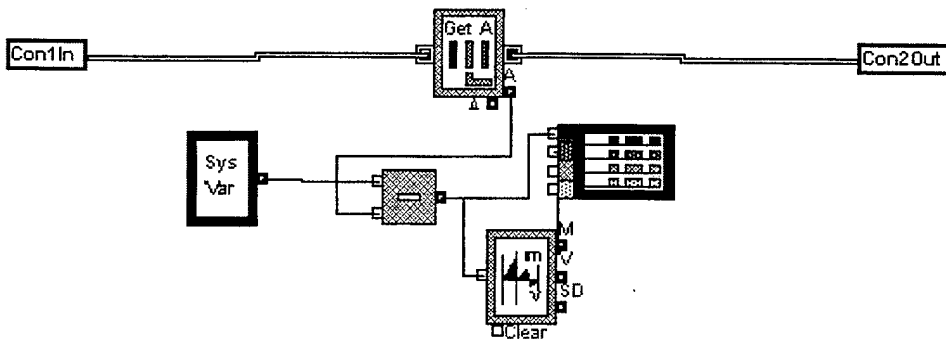

Figure C.1h – Delay Plotter Block



Model #2

Access Type: ATM
 Bandwidth: 28800 bps
 Receive Type: Symmetric
 Transmit Type: Regional
 Flow Control: Off

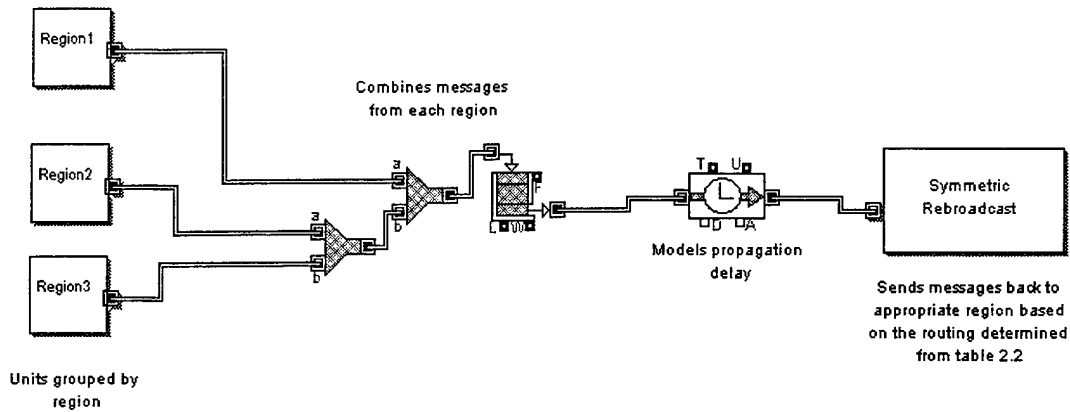

Figure C.2a – Top Layer of Model #2

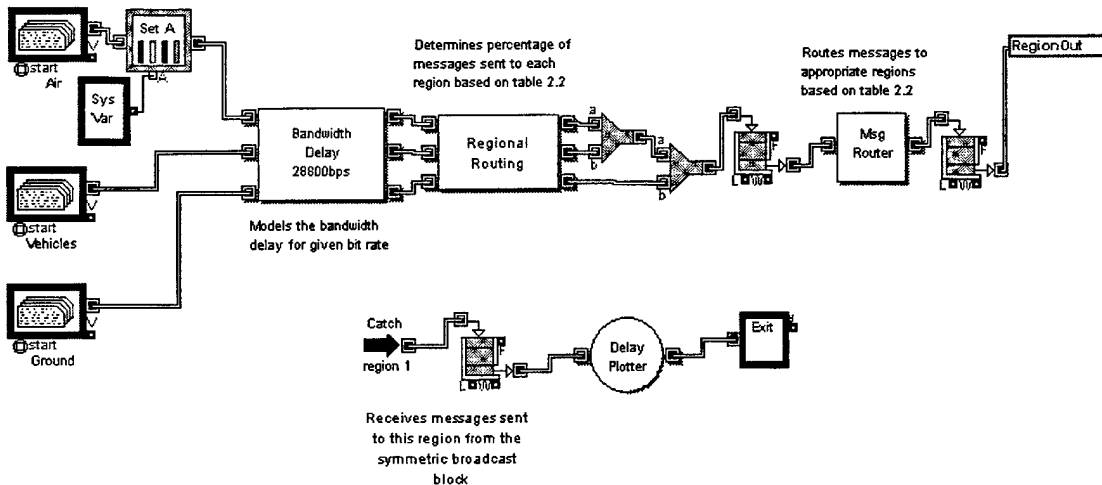

Figure C.2b – Region 1 of Model #2

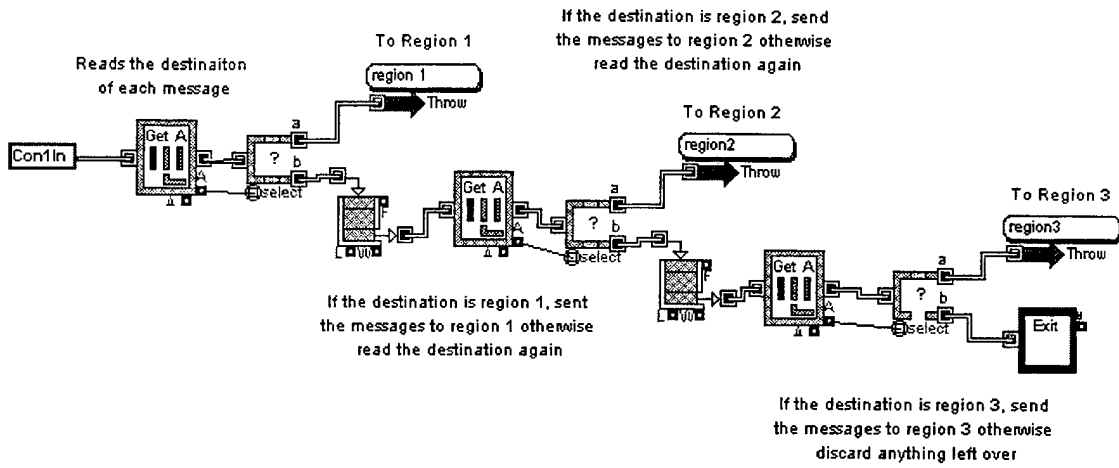

Figure C.2c – Symmetric Rebroadcast Block for Regional Grouping



Model #3

Access Type: TDMA
 Bandwidth: 9600 bps
 Receive Type: Symmetric
 Transmit Type: Type
 Flow Control: Off

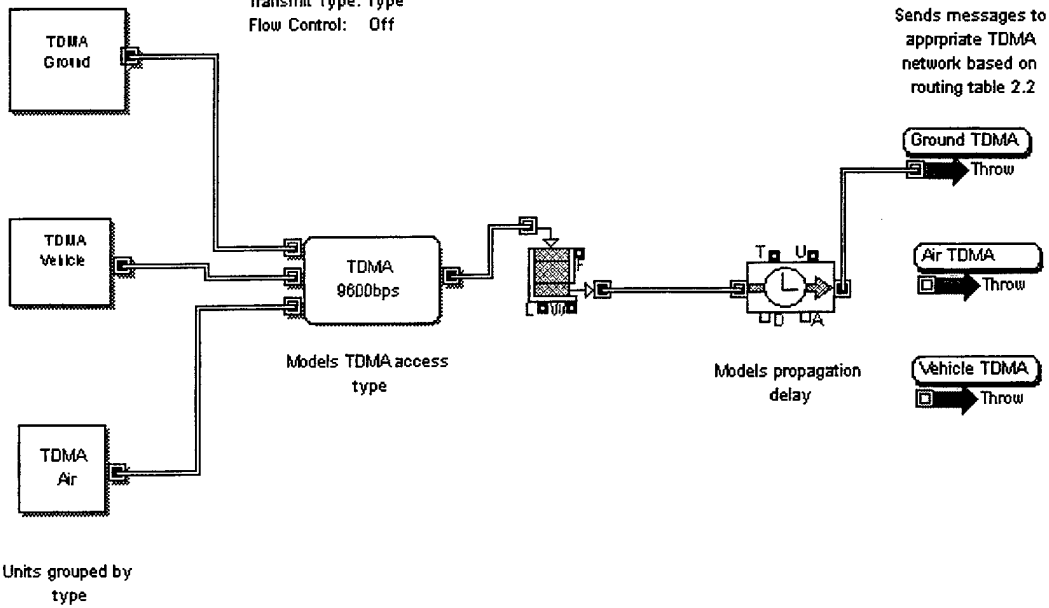

Figure C.3a – Top Layer of Model #3

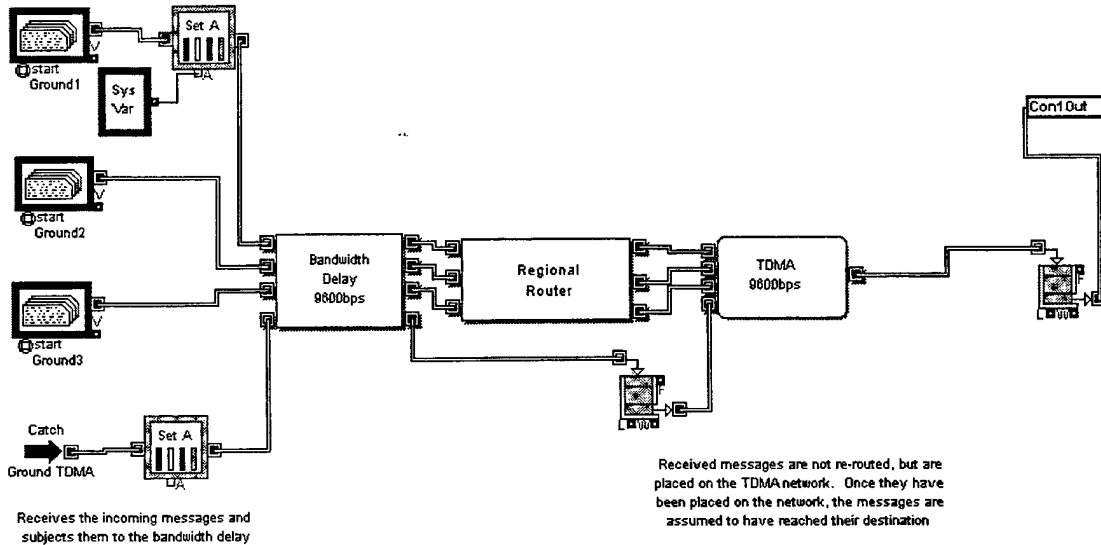

Figure C.3b – TDMA Ground Block for Model #3



Model #4

Access Type: ATM
Bandwidth: 28800 bps
Receive Type: Asymmetric
Transmit Type: Type
Flow Control: On

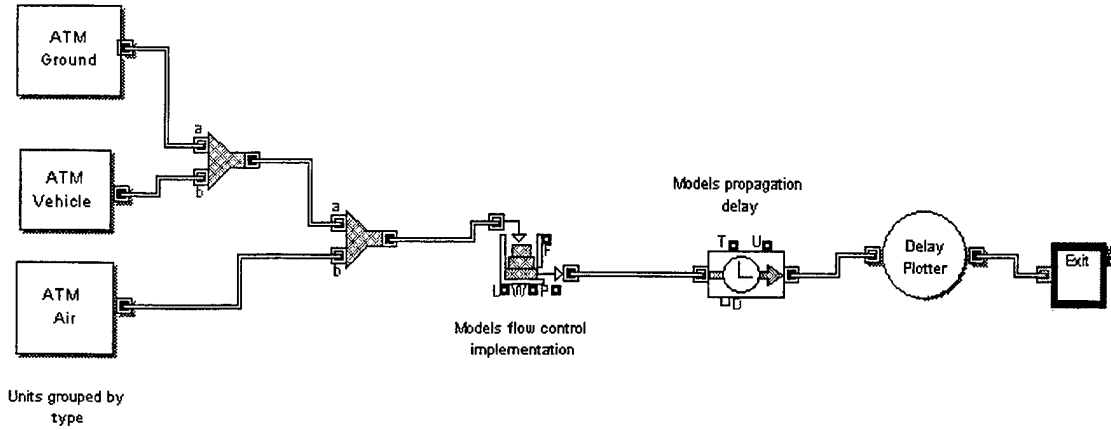

Figure C.4a – Top Layer of Model #4

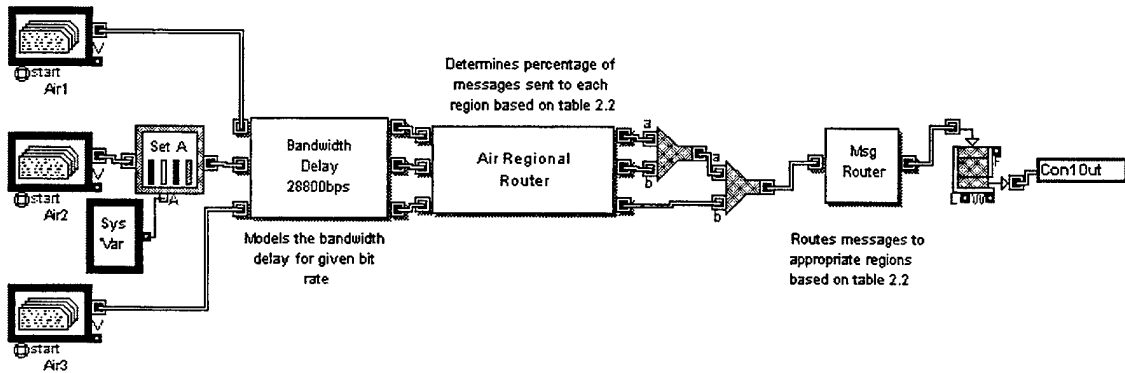

Figure C.4b – ATM Air Block for Model #4



Model #5

Access Type: TDMA
 Bandwidth: 28800 bps
 Receive Type: Asymmetric
 Transmit Type: Regional & Type
 Flow Control: Off

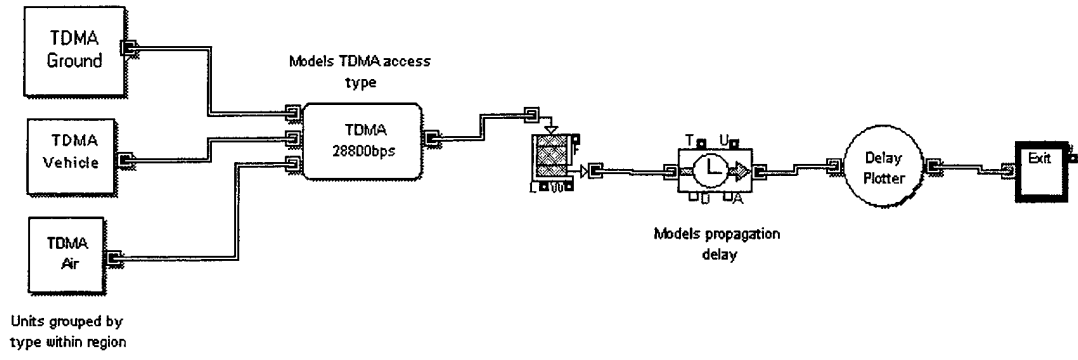

Figure C.5a – Top Layer of Model #5

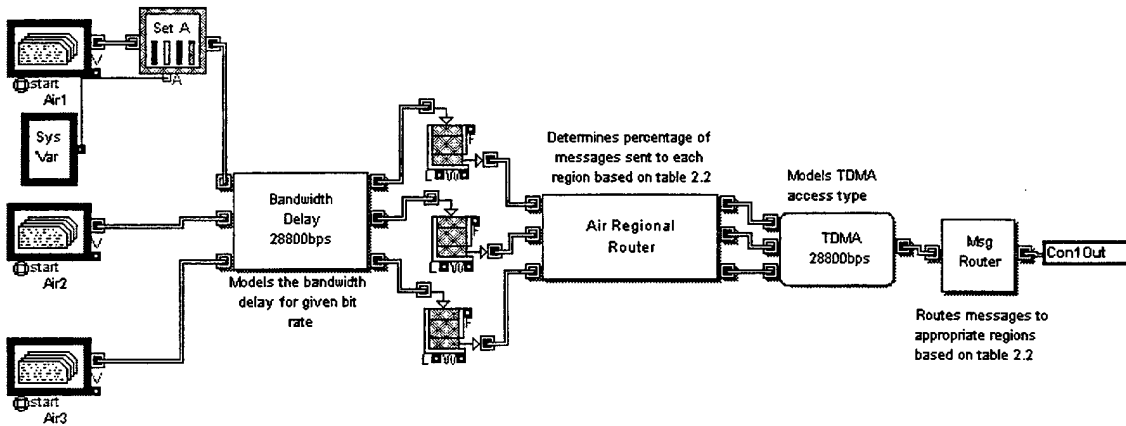

Figure C.5b – TDMA Air Block for Model #5



Model #6

Access Type: ATM
Bandwidth: 9600 bps
Receive Type: Symmetric
Transmit Type: Regional & Type
Flow Control: On

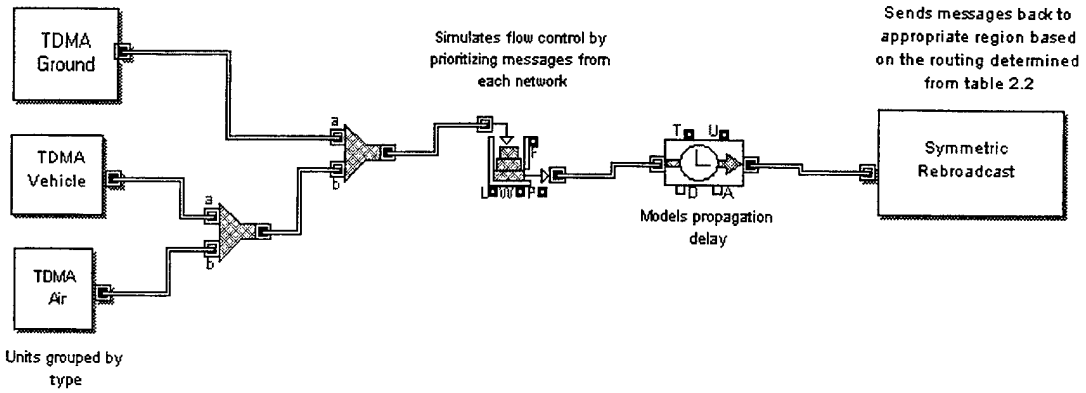

Figure C.6a – Top Layer of Model #6

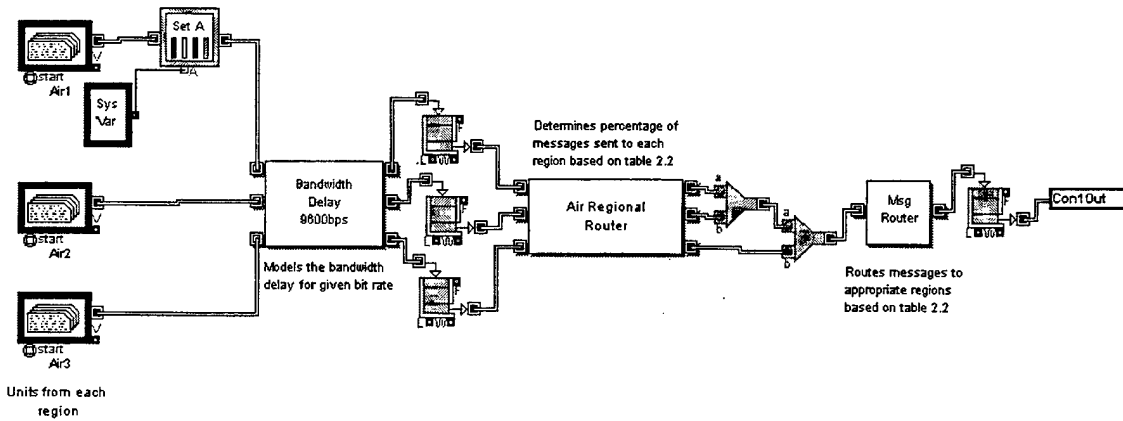

Figure C.6b – ATM Air Block for Model #6

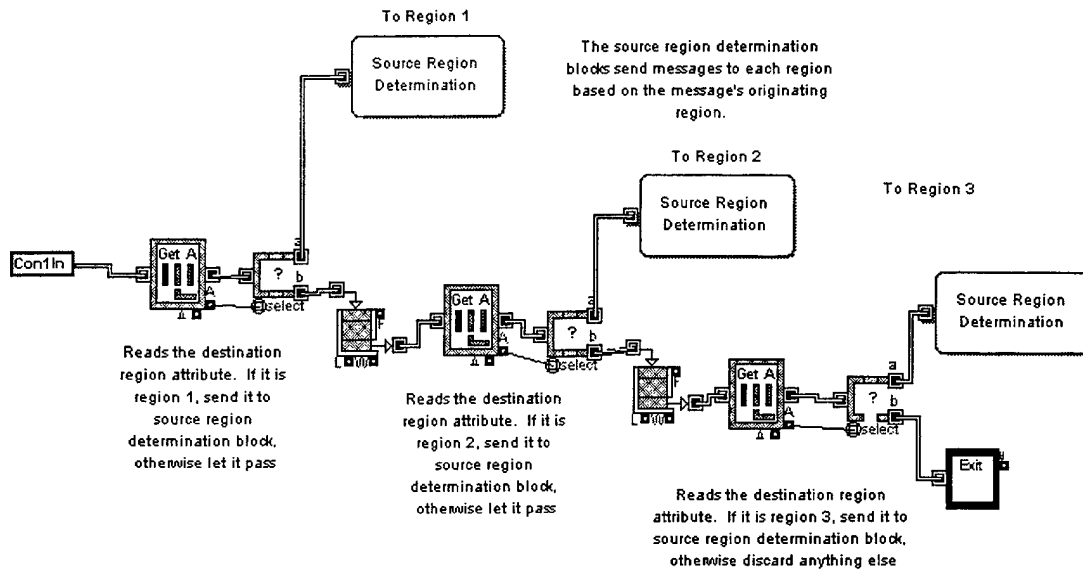

Figure C.6c – Symmetric Rebroadcast Block for Type in Region Grouping

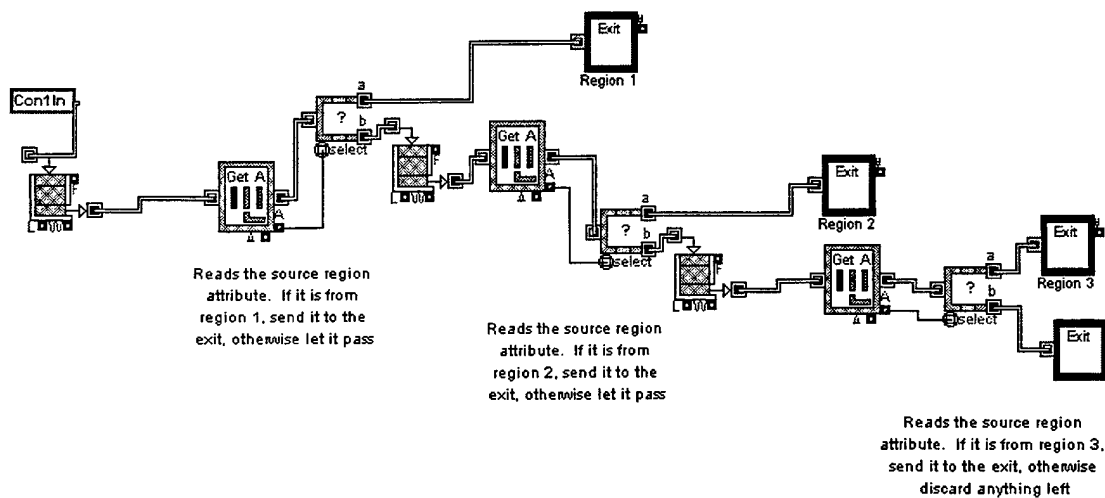

Figure C.6d – Source Region Determination Block for Type in Region Grouping



Model #7

Access Type: TDMA
Bandwidth: 28800 bps
Receive Type: Symmetric
Transmit Type: Regional
Flow Control: On

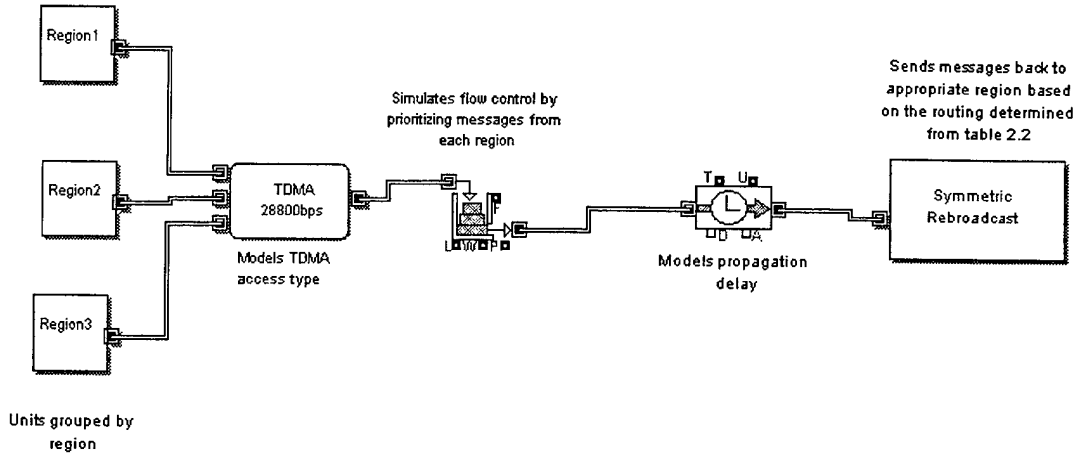

Figure C.7a – Top layer of Model #7

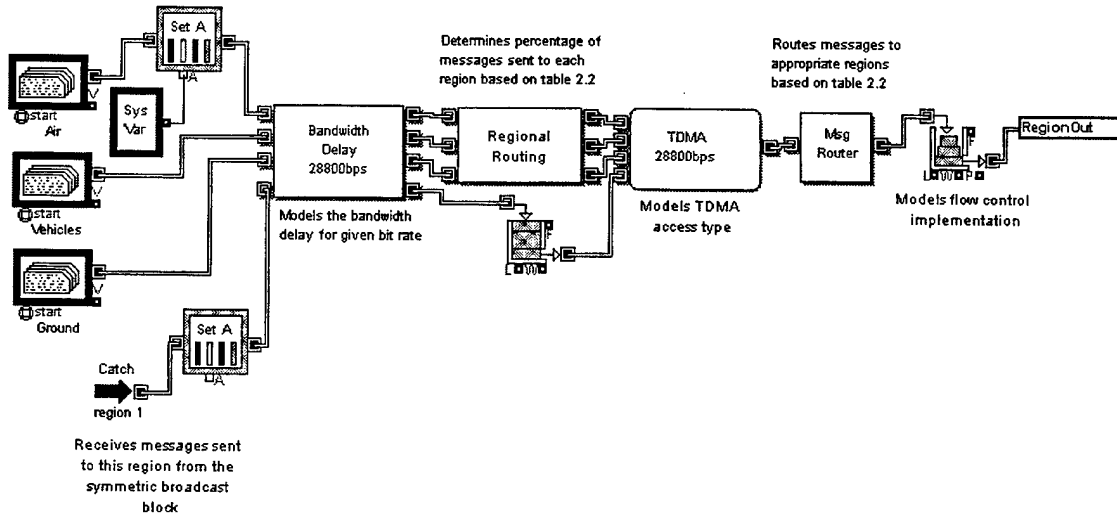

Figure C.7b – Region 1 of Model #7



Model #8

Access Type: ATM
Bandwidth: 9600 bps
Receive Type: Asymmetric
Transmit Type: Regional
Flow Control: Off

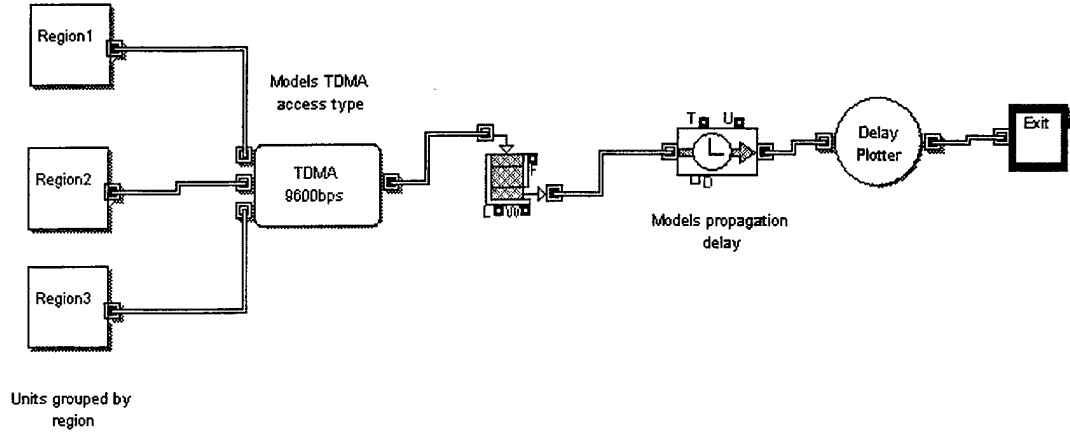

Figure C.8a – Top Layer of Model #8

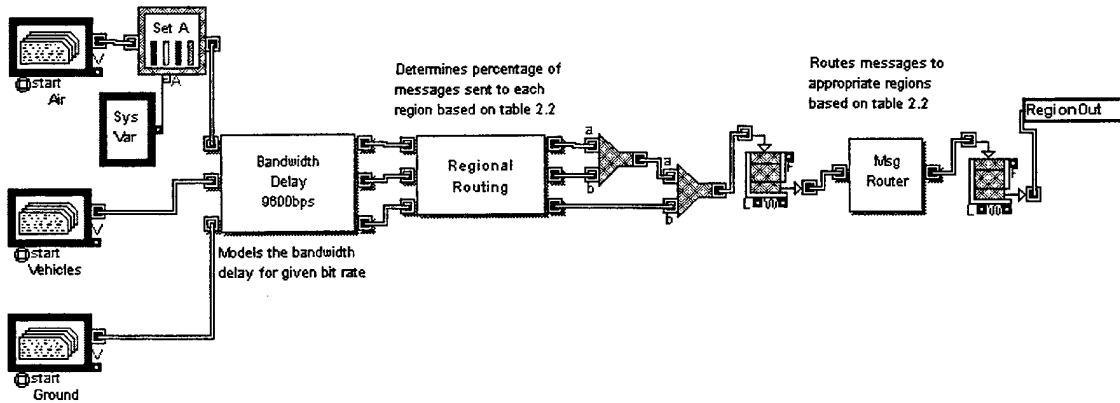

Figure C.8b – Region 1 of Model #8



Optimum Model

Access Type: ATM
Bandwidth: 28800 bps
Receive Type: Asymmetric
Transmit Type: Regional & Type
Flow Control: On

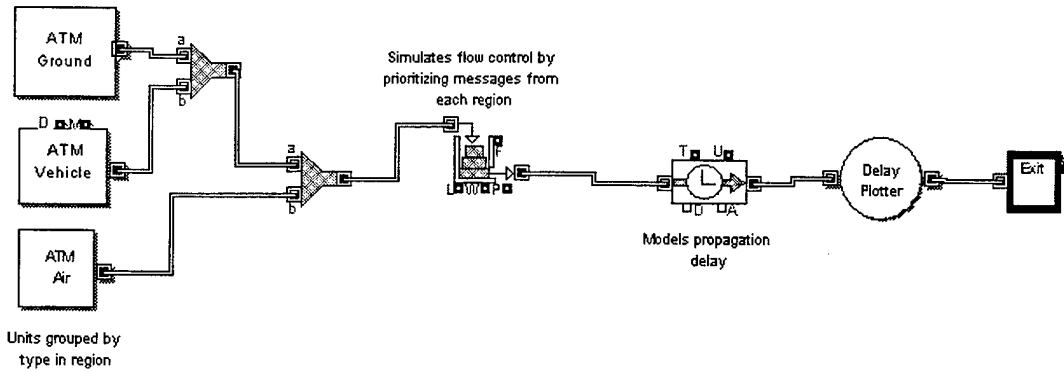

Figure C.9a – Top Layer of Optimum Model

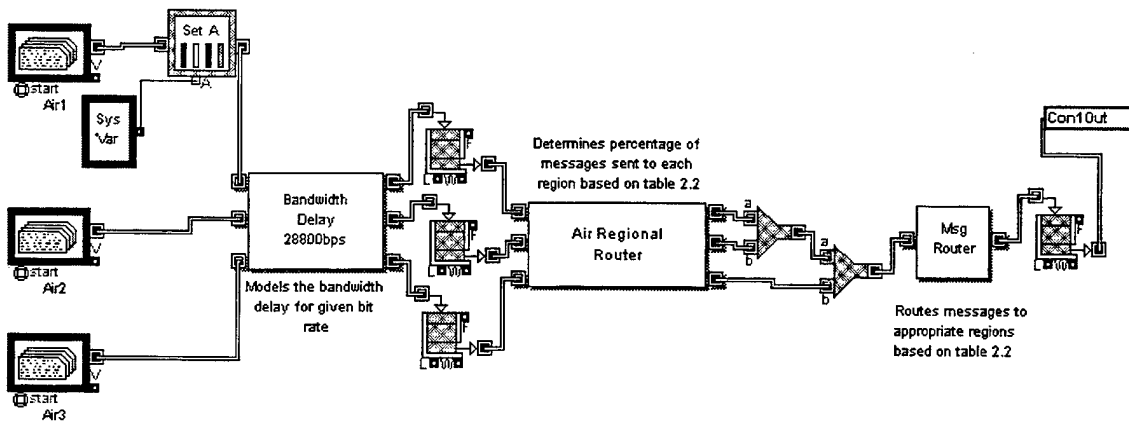

Figure C.9b – ATM Air Block of Optimum Model

LIST OF REFERENCES

1. Osmundson, John S., *Architectural Analysis of Composite Combat Identification and Tracking Systems*, Proceedings of the 1995 U.S. DoD Joint Service Combat Identification Systems Conference, 14-16 November, 1995, Naval Postgraduate School, Monterey, CA.
2. Byrd, Valerie R., *The Integration of Situational Awareness Beacon with Reply (SABER) with The Enhanced Position Location Reporting System (EPLRS)*, Master's Thesis, Naval Postgraduate School, Monterey, California, December 1996.
3. Roy, Ranjit, *A Primer on the Taguchi Method*, Van Nostrand Reinhold, 1990.
4. Extend Users Manual, Imagine That, Inc, 1995.

INITIAL DISTRIBUTION LIST

- 1. Defense Technical Information Center2
8725 John J. Kingman Rd. STE 0944
Ft. Belvoir, Virginia 22060-6218

- 2. Dudley Knox Library2
Naval Postgraduate School
411 Dyer Rd.
Monterey, California 93943-5101

- 3. Professor John Osmundson, CC/OS.....1
Naval Postgraduate School
Monterey, California 93943-5101

- 4. Professor Gordon Schacher, PH/SQ.....1
Naval Postgraduate School
Monterey, California 93943-5101

- 5. Lieutenant Scott Davis.....1
480A McClellan Ave.
Monterey, California 93940