

FINAL REPORT
APRIL 1997

REPORT NO. 96-62-1

MODULAR ARTILLERY CHARGE
SYSTEM (MACS) PA161E1
CONTAINER PALLET
MIL-STD-1660 TESTS

DISTRIBUTION STATEMENT A
Approved for public release;
Distribution Unlimited

19980415 071

Prepared for:
U.S. Army Armament Research, Development
and Engineering Center
ATTN: AMSTA-AR-ESK
Rock Island, IL 61299-7300

Distribution Unlimited

DTIC QUALITY INSPECTED 3



VALIDATION ENGINEERING DIVISION
SAVANNA, ILLINOIS 61074-9639

AVAILABILITY NOTICE

A copy of this report will be furnished each attendee on automatic distribution. Additional copies or authority for reprinting may be obtained by written request from Director, U.S. Army Defense Ammunition Center, ATTN: SIOAC-DEV, Savanna, IL 61074-9639.

DISTRIBUTION INSTRUCTIONS

Destroy this report when no longer needed. Do not return.

Citation of trade names in this report does not constitute an official endorsement.

The information contained herein will not be used for advertising purposes.

REPORT DOCUMENTATION PAGE				Form Approved OMB No. 0704-0188	
1a. REPORT SECURITY CLASSIFICATION UNCLASSIFIED		1b. RESTRICTIVE MARKINGS			
2a. SECURITY CLASSIFICATION AUTHORITY		3. DISTRIBUTION / AVAILABILITY OF REPORT UNLIMITED			
2b. DECLASSIFICATION / DOWNGRADING SCHEDULE					
4. PERFORMING ORGANIZATION REPORT NUMBER(S) 96-62-1		5. MONITORING ORGANIZATION REPORT NUMBER(S)			
6a. NAME OF PERFORMING ORGANIZATION U.S. Army Defense Ammunition Center		6b. OFFICE SYMBOL (if applicable) SIOAC-DEV	7a. NAME OF MONITORING ORGANIZATION		
6c. ADDRESS (City, State, and ZIP Code) ATTN: SIOAC-DEV Savanna, IL 61074-9639		7b. ADDRESS (City, State, and ZIP Code)			
8a. NAME OF FUNDING / SPONSORING ORGANIZATION U.S. Army Armament Research, Development and Engineering Center		8b. OFFICE SYMBOL (if applicable) AMSTA-AR-ESK	9. PROCUREMENT INSTRUMENT IDENTIFICATION NUMBER		
8c. ADDRESS (City, State, and ZIP Code) ATTN: AMSTA-AR-ESK Rock Island, IL 61299-7300		10. SOURCE OF FUNDING NUMBERS			
		PROGRAM ELEMENT NO.	PROJECT NO.	TASK NO.	WORK UNIT ACCESSION NO.
11. TITLE (Include Security Classification) Modular Artillery Charge System (MACS) PA161E1 Container Pallet MIL-STD-1660 Tests					
12. PERSONAL AUTHOR(S) Ejike J. Ajalla					
13a. TYPE OF REPORT Final		13b. TIME COVERED FROM _____ TO _____		14. DATE OF REPORT (Year, Month, Day) 1997 April	15. PAGE COUNT
16. SUPPLEMENTARY NOTATION					
17. COSATI CODES			18. SUBJECT TERMS (Continue on reverse if necessary and identify by block number)		
FIELD	GROUP	SUB-GROUP			
19. ABSTRACT (Continue on reverse if necessary and identify by block number) The U.S. Army Defense Ammunition Center (DAC), Validation Engineering Division (SIOAC-DEV), was tasked by U.S. Army Armament Research, Development and Engineering Center (ARDEC) to conduct MIL-STD-1660 tests on a Modular Artillery Charge System (MACS) PA161E1 container pallet. This report contains the procedures and test results from MIL-STD-1660, Design Criteria for Ammunition Unit Loads, tests conducted. The MACS PA161E1 container successfully passed MIL-STD-1660 tests.					
20. DISTRIBUTION / AVAILABILITY OF ABSTRACT <input checked="" type="checkbox"/> UNCLASSIFIED/UNLIMITED <input type="checkbox"/> SAME AS RPT. <input type="checkbox"/> DTIC USERS			21. ABSTRACT SECURITY CLASSIFICATION UNCLASSIFIED		
22a. NAME OF RESPONSIBLE INDIVIDUAL JEROME H. KROHN		22b. TELEPHONE (Include Area Code) 815-273-8929		22c. OFFICE SYMBOL SIOAC-DEV	

U.S. ARMY DEFENSE AMMUNITION CENTER
VALIDATION ENGINEERING DIVISION
SAVANNA, IL 61074-9639

REPORT NO. 96-62-1

MODULAR ARTILLERY CHARGE SYSTEM (MACS) PA161E1 CONTAINER PALLET
MIL-STD-1660 TESTS

TABLE OF CONTENTS

PART	PAGE NO.
1. INTRODUCTION.....	1-1
A. BACKGROUND	1-1
B. AUTHORITY	1-1
C. OBJECTIVE	1-1
D. CONCLUSION.....	1-1
2. ATTENDEES.....	2-1
3. TEST PROCEDURES	3-1
4. TEST EQUIPMENT	4-1
5. TEST RESULTS	5-1
6. PHOTOGRAPHS.....	6-1
7. DRAWING	7-1

PART 1

INTRODUCTION

A. BACKGROUND. The U.S. Army Defense Ammunition Center (DAC), Validation Engineering Division (SIOAC-DEV), was tasked by U.S. Army Armament Research, Development and Engineering Center (ARDEC) to conduct MIL-STD-1660 tests on a Modular Artillery Charge System (MACS) PA161E1 container pallet.

B. AUTHORITY. This test was conducted IAW mission responsibilities delegated by the U.S. Army Armament, Munitions and Chemical Command (AMCCOM), Rock Island, Illinois.

C. OBJECTIVE. The objective of these tests was to determine whether the MACS PA161E1 container pallet met MIL-STD-1660 requirements.

D. CONCLUSION. The MACS PA161E1 container pallet met MIL-STD-1660, Design Criteria for Ammunition Unit Loads, requirements.

PART 2

15 - 19 AUGUST 1996

ATTENDEES

Ejike J. Ajalla
Mechanical Engineer
DSN 585-8434
815-273-8434

Director
U.S. Army Defense Ammunition Center
ATTN: SIOAC-DEV
3700 Army Depot Road
Savanna, IL 61074-9639

Bradley J. Hass
Mechanical Engineer
DSN 585-8336
815-273-8336

Director
U.S. Army Defense Ammunition Center
ATTN: SIOAC-DEV
3700 Army Depot Road
Savanna, IL 61074-9639

Sanjeev Khanna
Mechanical Engineer
DSN 585-8083
815-273-8083

Director
U.S. Army Defense Ammunition Center
ATTN: SIOAC-DES
3700 Army Depot Road
Savanna, IL 61074-9639

PART 3

TEST PROCEDURES

The test procedures outlined in this section were extracted from MIL-STD-1660, Design Criteria for Ammunition Unit Loads, 8 April 1977. This standard identifies nine steps that a unitized load must undergo if it is to be considered acceptable. The four tests that were conducted on the test pallets are summarized below.

A. STACKING TEST. The unit load was loaded to simulate a stack of identical unit loads stacked 16 feet high, for a period of one hour. This stacking load was simulated by subjecting the unit load to a compression weight equal to an equivalent 16-foot stacking height. The compression load was calculated in the following manner. The unit load weight was divided by the unit load height in inches and multiplied by 192. The resulting number was the equivalent compressive force of a 16-foot-high load.

B. REPETITIVE SHOCK TEST. The repetitive shock test was conducted IAW Method 5019, Federal Standard 101. The test procedure is as follows: The test specimen was placed on, but not fastened to, the platform. With the specimen in one position, the platform was vibrated at 1/2-inch amplitude (1-inch double amplitude) starting at a frequency of approximately 3 cycles per second. The frequency was steadily increased until the package left the platform. The resonant frequency was achieved when a 1/16-inch-thick feeler gage momentarily slid freely between every point on the specimen in contact with the platform at some instance during the cycle or a platform acceleration achieved 1 +/- 0.1 Gs. Midway into the testing period, the specimen was rotated 90 degrees and the test continued for the duration. Unless failure occurred, the total time of vibration was two hours if the specimen was tested in one position and three hours for more than one position.

C. EDGEWISE ROTATIONAL DROP TEST. This test was conducted using the procedures of Method 5008, Federal Standard 101. The procedure for the edgewise rotational drop test is as follows: The specimen was placed on its skids with one end of the pallet supported on a beam 4-1/2 inches high. The height of the beam was increased if necessary to ensure that there was no support for the skids between the ends of the pallet when dropping took place, but was not high enough to cause the pallet to slide on the supports when the dropped end was raised for the drops. The unsupported end of the pallet was then raised and allowed to fall freely to the concrete, pavement, or similar underlying surface from a prescribed height. Unless otherwise specified, the height of drop for level A protection conforms to the following tabulation:

GROSS WEIGHT (WITHIN RANGE LIMITS) (Pounds)	DIMENSIONS OF ANY EDGE, HEIGHT OR WIDTH (WITHIN RANGE LIMITS) (Inches)	HEIGHT OF DROPS ON EDGES	
		Level A	Level B
		(Inches)	(Inches)
150 - 250	60 - 66	36	27
250 - 400	66 - 72	32	24
400 - 600	72 - 80	28	21
600 - 1000	80 - 95	24	18
1000 - 1500	95 - 114	20	16
1500 - 2000	114 - 144	17	14
2000 - 3000	Above 145 - No limit	15	12
Above - 3000		12	9

D. INCLINE-IMPACT TEST. This test was conducted by using the procedure of Method 5023, Incline-Impact Test of Federal Standard 101. The procedure for the incline-impact test is as follows: The specimen was placed on the carriage with the surface or edge which is to be

impacted projecting at least 2 inches beyond the front end of the carriage. The carriage was brought to a predetermined position on the incline and released. If it is desired to concentrate the impact on any particular position on the container, a 4- by 4-inch timber was attached to the bumper in the desired position before the test. No part of the timber was struck by the carriage. The position of the container on the carriage and the sequence in which surfaces and edges are subjected to impacts was at the option of the testing activity and depends upon the objective of the tests. This test is to determine satisfactory requirements for a container or pack, and, unless otherwise specified, the specimen was subjected to one impact on each surface that has each dimension less than 9.5 feet. Unless otherwise specified, the velocity at time of impact was 7 feet per second.

PART 4

TEST EQUIPMENT

A. Pallet (Test Sample).

1. Size: 31.5- by 46.5-inch
2. Pallet Load: PA161E1 containers
3. Quantity of Containers: 36
4. Weight Loaded: 1,740 pounds
5. Unit Load Height: 52 inches

B. Compression Tester.

1. Manufacturer: Ormond Manufacturing
2. Platform: 60- by 60-inch
3. Compression Limit: 50,000 pounds
4. Tension Limit: 50,000 pounds

C. Transportation Simulator.

1. Manufacturer: Gaynes Laboratory
2. Capacity: 6,000-pounds
3. Displacement: 1/2-inch amplitude
4. Speed: 50 to 400 rpm
5. Platform: 5- by 8-foot

D. Inclined Plane.

1. Manufacturer: Conbur Incline
2. Type: Impact Tester
3. Grade: 10 percent incline
4. Length: 12-foot

PART 5

TEST RESULTS

TEST OBSERVATIONS: Each pallet was loaded with 36 PA161E1 containers IAW DAC drawing 19-48-4231/50. Each container was filled with approximately 34 pounds of iron granules, creating a total 1,740-pound unitized load.

A. STACKING TEST. The test sample was initially loaded to 7,000 pounds compression. After 1 hour, the compression was released. No physical damage to the test sample was noticed.

B. REPETITIVE SHOCK TEST. The duration of the test was 90 minutes for each orientation of the test sample. In order to achieve a clearance between the test sample and the transportation simulator bed, the equipment was operated at 165 rpm for the longitudinal orientation and 166 rpm for the lateral orientation. No physical damage was noticed at the end of this test.

C. EDGEWISE ROTATIONAL DROP TEST. Each side of the pallet was placed on a beam displacing it 4-1/2 inches above the floor. The opposite end of the test pallet was raised to a height of 17 inches, then dropped. This process was repeated in a clockwise direction until all four sides of the pallet had been tested. There was no physical damage noticed at the end of this test.

D. INCLINE-IMPACT TEST. The incline-plane was set to allow the pallet to travel 8 feet prior to impacting a stationary wall. The pallet was rotated clockwise after each impact, until all four sides had been tested. No physical damage was noticed at the end of this test.

E. END OF TEST INSPECTION. During final inspection, there was no physical damage noticed on the test sample.

PART 6

PHOTOGRAPHS



U.S. ARMY DEFENSE AMMUNITION CENTER AND
SCHOOL - SAVANNA, IL

A0317-SCN-96-173-4413. This photo shows the configuration of the palletized unit load.

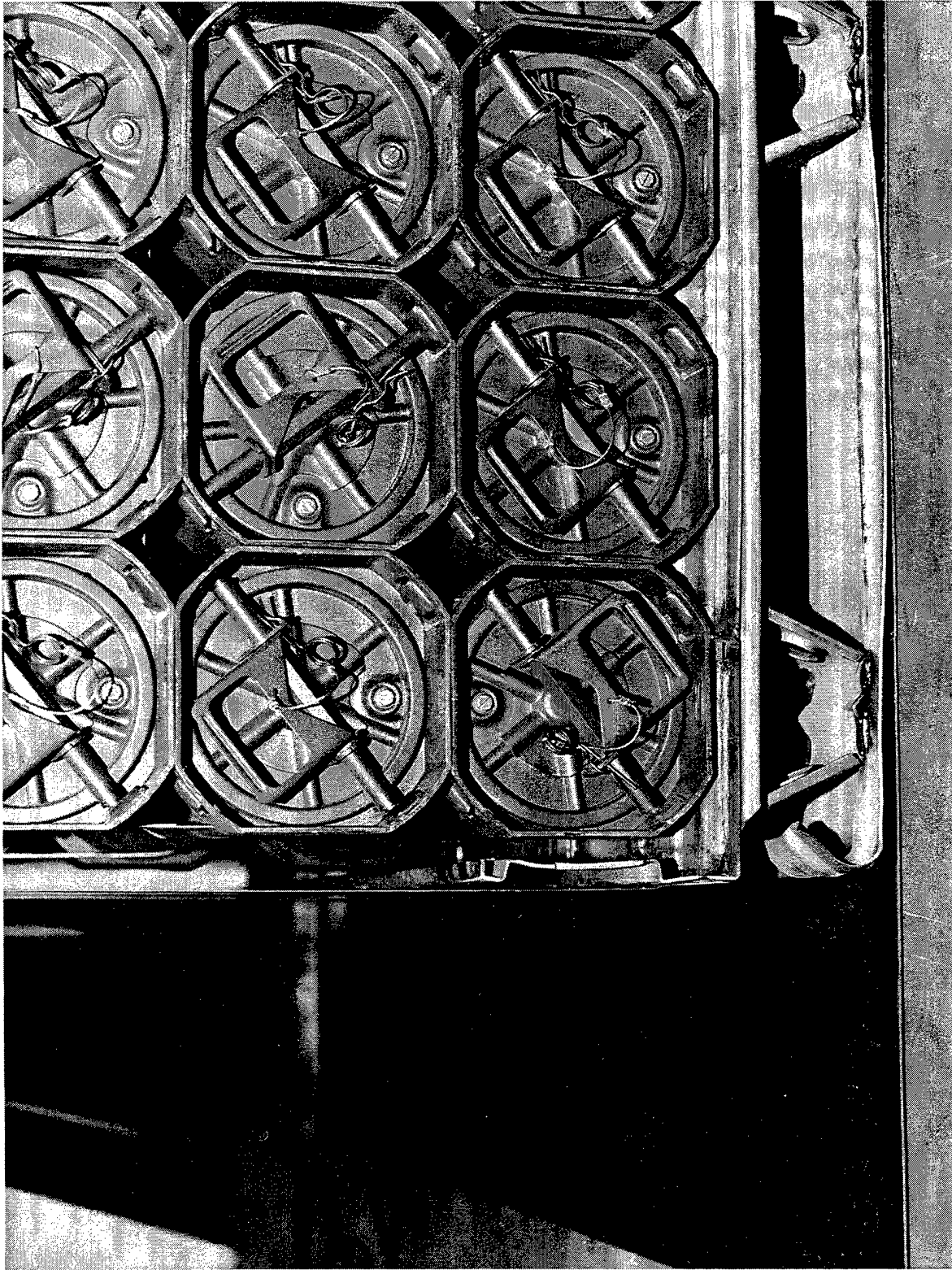

U.S. ARMY DEFENSE AMMUNITION CENTER -
SAVANNA, IL

AO317-SCN-96-173-4414. This photo shows a bottom view of the pallet unitized load following completion of MIL-STD-1660 tests.

PART 7

DRAWING

APPENDIX 50

UNITIZATION PROCEDURES FOR AMMUNITION AND COMPONENTS PACKED IN CYLINDRICAL METAL ON 4-WAY ENTRY METAL PALLETS

MODULAR ARTILLERY CHARGE SYSTEM (MACS),
XM231, PACKED 4 PER PA161E1 CYLINDRICAL
METAL CONTAINER, UNITIZED 36 PER 46-1/2"
X 31-3/8" PALLET; APPROX CONTAINER SIZE
31-3/8" L X 7-1/2" W X 7-1/2" H

NOTICE: THIS APPENDIX CANNOT STAND ALONE BUT MUST BE USED IN CONJUNCTION WITH
THE BASIC UNITIZATION PROCEDURES DRAWING 19-48-4231-20PM1006.

DISTRIBUTION STATEMENT A.

APPROVED FOR PUBLIC RELEASE:
DISTRIBUTION IS UNLIMITED.

DO NOT SCALE

U.S. ARMY MATERIEL COMMAND DRAWING				
APPROVED, U.S. ARMY INDUSTRIAL OPERATIONS COMMAND		DRAFTSMAN ENGINEER	BETTY J. KUNDERT SANDRA M. SCHULTZ	
AMSTA-AR-ESK AMSIO-TMJ		SUPPLY ENGINEERING DIVISION	TRANSPORTATION ENGINEERING DIVISION	VALIDATION ENGINEERING DIVISION
APPROVED BY ORDER OF COMMANDING GENERAL, U.S. ARMY MATERIEL COMMAND		LOGISTICS ENGINEERING OFFICE		
U.S. ARMY DEFENSE AMMUNITION CENTER		FEBRUARY 1997		
		CLASS	DIVISION	DRAWING
		19	48	4231/ 50
				FILE 20PM. 1006

PALLET UNIT DATA				
ITEMS INCLUDED		HAZARD CLASS AND DIVISION *		APPROX WEIGHT LBS
NSN	DODIC	DD CLASS	COMP GROUP	
1320-UNAS	---	-----	-	1,476

* HAZARD CLASSIFICATION DATA CONTAINED IN THE ABOVE CHART IS FOR GUIDANCE AND INFORMATIONAL PURPOSES ONLY. VERIFICATION OF THE SPECIFIED DATA SHOULD BE MADE BY CONSULTING THE MOST RECENT JOINT HAZARD CLASSIFICATION SYSTEM LISTING OR OTHER APPROVED LISTING(S).

GENERAL NOTES

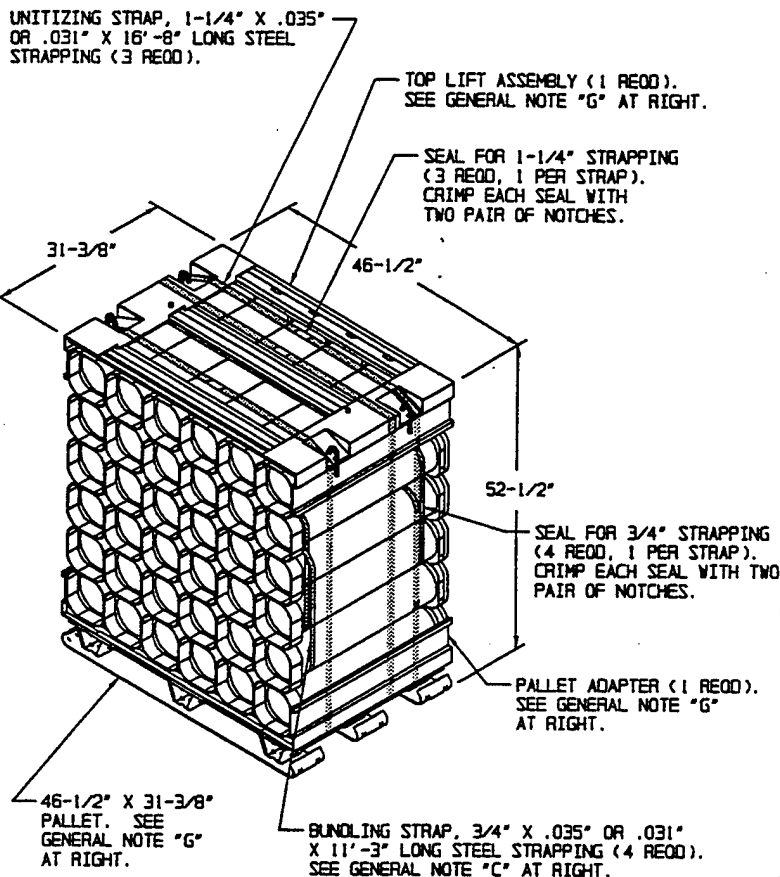

PALLET UNIT

SEE GENERAL NOTE "B" AT RIGHT.

36 CONTAINERS OF MACS (4 PER CNTR) AT 34 LBS	-----	1,224 LBS (APPROX)
DUNNAGE	-----	157 LBS
PALLET	-----	95 LBS
TOTAL WEIGHT	-----	1,476 LBS (APPROX)
CUBE	-----	44.3 CU FT (APPROX)

BILL OF MATERIAL

METAL PALLET, 46-1/2" X 31-3/8"	1 REOD	95 LBS
PALLET ADAPTER	1 REOD	70 LBS
TOP LIFT ASSEMBLY	1 REOD	75 LBS
STEEL STRAPPING, 3/4"	45.00' REOD	4.02 LBS
STEEL STRAPPING, 1-1/4"	50.00' REOD	7.58 LBS
SEAL FOR 3/4" STRAPPING	4 REOD	NIL
SEAL FOR 1-1/4" STRAPPING	3 REOD	NIL

- A. THIS APPENDIX CANNOT STAND ALONE BUT MUST BE USED IN CONJUNCTION WITH THE BASIC UNITIZATION PROCEDURES DRAWING 19-48-4231-20PM1006. TO PRODUCE AN APPROVED UNIT LOAD, ALL PERTINENT PROCEDURES, SPECIFICATIONS AND CRITERIA SET FORTH WITHIN THE BASIC DRAWING WILL APPLY TO THE PROCEDURES DELINEATED IN THIS APPENDIX. ANY EXCEPTIONS TO THE BASIC PROCEDURES ARE SPECIFIED IN THIS APPENDIX.
- B. DIMENSIONS, CUBE AND WEIGHT OF A PALLET UNIT WILL VARY SLIGHTLY DEPENDING UPON THE ACTUAL DIMENSIONS OF THE BOXES AND THE WEIGHT OF THE SPECIFIC ITEM BEING UNITIZED.
- C. BUNDLING STRAPS MUST BE TENSIONED AND SEALED PRIOR TO THE APPLICATION OF THE UNITIZING STRAPS. INSTALL BUNDLING STRAPS AS CLOSE TO THE OUTER CONTAINER RINGS AS POSSIBLE, TO AVOID DAMAGE TO THE CONTAINERS. CAUTION: STRAPS MUST NOT BE ALLOWED TO OVERLAP.
- D. ALTHOUGH THE CONTAINERS DEPICTED IN THE UNIT LOAD AT LEFT ARE CONSTRUCTED WITH INTERLOCKING DEVICES, THE INTERLOCKS WILL NOT FUNCTION PROPERLY UNLESS THE CONTAINERS ARE POSITIONED SO THAT THE "PINS" OF THE INTERLOCKS ARE FACING UPWARD. THIS ORIENTATION WILL AID IN THE PREVENTING OF CONTAINER MOVEMENT, BOTH Laterally and Longitudinally, DURING SHIPMENT OF THE UNIT LOAD.
- E. THE FOLLOWING AMC DRAWINGS ARE APPLICABLE FOR OUTLOADING AND STORAGE OF THE ITEMS COVERED BY THIS APPENDIX.
 - CARLOADING ----- 19-48-4242/50-SPM1004
 - TRUCKLOADING ----- 19-48-4243/50-11PM1004
 - STORAGE -----
 - 19-48-4250/50-1-2-3-4-14-22PM1005
 - END OPENING ISO
 - CONTAINER ----- 19-48-4245/50-15PM1009
 - MILVAN ----- 19-48-4244/50-15PM1008
 - SIDE OPENING ISO
 - CONTAINER ----- 19-48-4272/50-15PM1016
- F. IF ITEMS COVERED HEREIN ARE UNITIZED PRIOR TO ISSUANCE OF THIS APPENDIX, THE CONTAINERS NEED NOT BE REUNITIZED SOLELY TO CONFORM TO THIS APPENDIX.
- G. FOR DETAILS OF PALLET AND PALLET ADAPTERS, SEE AMCCOM DRAWING ACV00300, MIL-A-70788 AND MIL-P-70786.
- H. THE UNITIZATION PROCEDURES DEPICTED HEREIN MAY ALSO BE USED FOR UNITIZING MACS WHEN IDENTIFIED BY DIFFERENT NATIONAL STOCK NUMBERS (NSN) THAN WHAT IS SHOWN ON PAGE 2, PROVIDED THE CONTAINER DOES NOT VARY FROM WHAT IS DELINEATED HEREIN. THE EXPLOSIVE CLASSIFICATION OF OTHER ITEMS MAY BE DIFFERENT THAN WHAT IS SHOWN.
- J. EMPTY OR REJECT PA161E1 CONTAINERS WILL BE USED AS FILLER CONTAINERS AS NECESSARY. FILLER CONTAINERS MUST BE INSTALLED IN THE MIDDLE OF THE TOP LAYER(S) OF CONTAINERS. IF SIX FULL CONTAINERS ARE TO BE OMITTED, ONE FULL LAYER OF CONTAINERS WILL BE OMITTED. WHEN (EMPTY) FILLER CONTAINERS ARE USED IN PLACE OF OMITTED CONTAINERS TO COMPLETELY FILL OUT A LAYER ON A PALLET, THEY WILL BE MARKED AS SPECIFIED IN MIL-STD-129-1.
- K. WHEN TWO OR MORE LAYERS ARE OMITTED, THE BUNDLING STRAP REQUIREMENT WILL CHANGE. A FOUR LAYER UNIT WILL HAVE THE TWO BUNDLING STRAPS OMITTED THAT WERE AROUND THE THIRD, FOURTH AND FIFTH LAYERS. THE REMAINING BUNDLING STRAPS WILL SURROUND THE SECOND THROUGH FOURTH LAYERS. A UNIT WITH THREE OR LESS LAYERS DOES NOT REQUIRE BUNDLING STRAPS.
- L. FOR DETAILS OF PA161E1 CONTAINER SEE ARDEC DRAWING 12972583.

