

NAVAL POSTGRADUATE SCHOOL Monterey, California



DEED QUALITY LIBRARY 10

THESIS

**ANALYSIS OF THE USE OF THE MACH-ZENDER
COUPLER IN DEMODULATING
MULTIPLEXED FIBER OPTIC SIGNALS**

by

Paul W. Wehner

September, 1997

Advisor:

Tri Ha

Approved for public release; distribution is unlimited.

19980413 129

REPORT DOCUMENTATION PAGE

Form Approved
OMB No. 0704-0188

Public reporting burden for this collection of information is estimated to average 1 hour per response, including the time for reviewing instruction, searching existing data sources, gathering and maintaining the data needed, and completing and reviewing the collection of information. Send comments regarding this burden estimate or any other aspect of this collection of information, including suggestions for reducing this burden, to Washington headquarters Services, Directorate for Information Operations and Reports, 1215 Jefferson Davis Highway, Suite 1204, Arlington, VA 22202-4302, and to the Office of Management and Budget, Paperwork Reduction Project (0704-0188) Washington DC 20503.

1. AGENCY USE ONLY (Leave blank)

2. REPORT DATE
September 1997

3. REPORT TYPE AND DATES COVERED
Master's Thesis

4. TITLE AND SUBTITLE
Analysis of the Use of the Mach-Zender Coupler In Demodulating Multiplexed Fiber Optic Signals

5. FUNDING NUMBERS

6. AUTHOR(S)
Wehner, Paul W.

7. PERFORMING ORGANIZATION NAME(S) AND ADDRESS(ES)
Naval Postgraduate School
Monterey, CA 93943-5000

8. PERFORMING ORGANIZATION REPORT NUMBER

9. SPONSORING / MONITORING AGENCY NAME(S) AND ADDRESS(ES)

10. SPONSORING / MONITORING AGENCY REPORT NUMBER

11. SUPPLEMENTARY NOTES

The views expressed in this thesis are those of the author and do not reflect the official policy or position of the Department of Defense or the U.S. Government.

12a. DISTRIBUTION / AVAILABILITY STATEMENT

Approved for public release; distribution unlimited.

12b. DISTRIBUTION CODE

13. ABSTRACT (maximum 200 words)

Fiber optic communications are the future of U.S. Navy shipboard communications. They present tremendous bandwidths with no susceptibility to electro-magnetic interference (EMI) and outstanding signal-to-noise ratios. Current technology uses wavelength division multiplexing (WDM) to allow multiple users on a single fiber simultaneously. The optical filters necessary to demodulate the WDM signal can be expensive. A less costly alternative could be achieved if Hadamard-Walsh Code Shift Keyed (CSK) encoded signals were used. An optical receiver was proposed, using the Mach-Zender coupler, capable of demodulating a Hadamard-Walsh CSK encoded signal. Building on previous work studying the characteristics of the Mach-Zender coupler, a relationship between the probability of bit error and signal-to-noise ratio (SNR) was developed for a single user and a DPSK optical signal. This relationship was then used to develop an understanding of the bit-error rate to SNR relationship for a multiple-user CSK optical signal. Using the theoretical performance as a guide, a MATLAB model was then constructed to investigate the sensitivity of the receiver to non-ideal components.

14. SUBJECT TERMS

fiber optic signal demultiplexing, mach-zender coupler

15. NUMBER OF PAGES
68

16. PRICE CODE

17. SECURITY CLASSIFICATION OF REPORT
Unclassified

18. SECURITY CLASSIFICATION OF THIS PAGE
Unclassified

19. SECURITY CLASSIFICATION OF ABSTRACT
Unclassified

20. LIMITATION OF ABSTRACT
UL

NSN 7540-01-280-5500

Standard Form 298 (Rev. 2-89)
Prescribed by ANSI Std.

239-18

**ANALYSIS OF THE USE OF THE MACH-ZENDER
COUPLER IN DEMODULATING
MULTIPLEXED FIBER OPTIC SIGNALS**

Paul W. Wehner
Lieutenant, United States Navy
BSAE, United States Naval Academy, 1989

Submitted in partial fulfillment of the
requirements for the degree of

MASTER OF SCIENCE IN ELECTRICAL ENGINEERING

from the

**NAVAL POSTGRADUATE SCHOOL
September 1997**

Author:

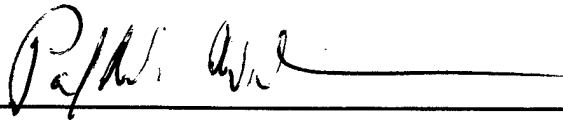

Paul W. Wehner

Approved by:



Tri Ha, Advisor

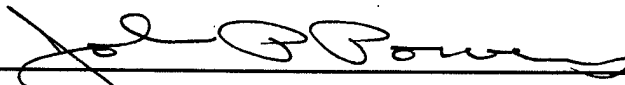

John P. Powers, Second Reader

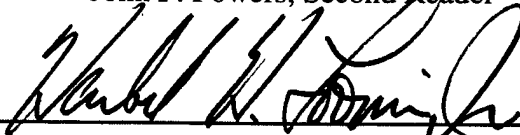

Herschel H. Loomis Jr, Chairman
Department of Electrical and
Computer Engineering

ABSTRACT

Fiber optic communications are the future of U.S. Navy shipboard communications. They present tremendous bandwidths with no susceptibility to electromagnetic interference (EMI) and outstanding signal-to-noise ratios. Current technology uses wavelength division multiplexing (WDM) to allow multiple users on a single fiber simultaneously. The optical filters necessary to demodulate the WDM signal can be expensive. A less costly alternative could be achieved if Hadamard-Walsh Code Shift Keyed (CSK) encoded signals were used. An optical receiver was proposed, using the Mach-Zender coupler, capable of demodulating a Hadamard-Walsh CSK encoded signal. Building on previous work studying the characteristics of the Mach-Zender coupler, a relationship between the probability of bit error and signal-to-noise ratio (SNR) was developed for a single user and a DPSK optical signal. This relationship was then used to develop an understanding of the bit-error rate to SNR relationship for a multiple-user CSK optical signal. Using the theoretical performance as a guide, a MATLAB model was then constructed to investigate the sensitivity of the receiver to non-ideal components.

TABLE OF CONTENTS

I.	INTRODUCTION.....	1
II.	DEVELOPMENT OF A MATHEMATICAL MODEL FOR THE MACH-ZENDER COUPLER.....	5
	A. OVERVIEW OF MACH-ZENDER COUPLER.....	5
	B. DEVELOPING A MATHEMATICAL MODEL.....	6
	1. Coupler Analysis.....	6
	2. Delay Element Analysis.....	8
	3. Phase Shift Element Analysis.....	9
	C. INPUT SIGNAL ANALYSIS.....	9
	D. SUMMARY.....	11
III.	DPSK DEMODULATION ANALYSIS.....	13
	A. INPUT DPSK SIGNAL.....	13
	B. RECEIVER ANALYSIS.....	14
	1. Output of Mach-Zender Coupler.....	14
	2. Photodetector Analysis.....	14
	3. Amplifier Analysis.....	15
	4. Integrator Analysis.....	15
	5. Decision Variable Analysis.....	17
	C. PROBABILITY OF BIT ERROR.....	19
	D. SUMMARY.....	19
IV.	CSK DEMODULATION ANALYSIS.....	21
	A. INTRODUCTION.....	21
	B. INPUT CSK HADAMARD-WALSH ENCODED SIGNAL.....	22
	C. RECEIVER ANALYSIS.....	24
	1. Output of First Stage Mach-Zender Coupler.....	24
	2. Output of Second Stage Mach-Zender Couplers.....	25
	3. Photodetector Analysis.....	25
	4. Amplifier Analysis.....	26
	5. Integrator Analysis.....	27
	6. Decision Variable Analysis.....	28
	D. PROBABILITY OF BIT ERROR.....	29
	E. SUMMARY.....	30
V.	SIMULATION AND SENSITIVITY ANALYSIS.....	33

A.	SIMULATION.....	33
1.	Design Approach.....	33
2.	Mach-Zender Coupler Simulation Construction.....	33
3.	Electrical Receiver Element Simulation.....	34
4.	Statistical Analysis.....	34
B.	SENSITIVITY ANALYSIS.....	34
1.	Delay Error.....	34
2.	Phase Shift Error.....	36
C.	SUMMARY.....	37
VI.	CONCLUSION.....	39
A.	DISCUSSION OF RESULTS.....	39
B.	FUTURE RESEARCH.....	40
	APPENDIX A. ANALYSIS OF THE OUTPUT OF TWO MACH ZENDER COUPLERS FOR CSK ENCODED SIGNAL.....	41
	APPENDIX B. MATLAB SIMULATION PROGRAMS.....	45
	LIST OF REFERENCES.....	57
	INITIAL DISTRIBUTION LIST.....	59

I. INTRODUCTION

The majority of data transported through modern U.S. Naval platforms is carried on copper wire or coaxial cable. As the amount of data being transferred dramatically increases, the need for a more efficient methods of transport arises. Given the tremendous increase in bandwidth of fiber optics, its use to transport data in naval platforms is becoming standard. Not only does fiber optic communication offer a tremendous bandwidth, it offers many other desirable characteristics that include resistance to electromagnetic interference (EMI) and an excellent signal-to-noise ratio that make its use on naval platforms extremely attractive.

To design the information flow in naval vessels of the future, it is important to study methods of optical data transmission and explore ways to improve upon and exploit the tremendous bandwidth available. In this thesis an alternative to Wave Division Multiplexing (WDM) will be developed and analyzed. This alternative relies upon the use of a specialized coupler, the Mach-Zender coupler, to demodulate the multiplexed optical signal into individual signal components.

The Mach-Zender coupler is composed of two 2x2 optical couplers, a delay line and a phase shift element. The signal enters the first coupler input port (port 1) as shown in Figure 1.1 and is equally divided between the output ports A and B. Signal a_1 is then delayed one bit period (T) and becomes signal a_1' . Both signals then enter the second coupler are combined and then equally divided to the output ports A and B. The signal b_2' is then phase shifted $-\pi/2$ radians giving the outputs of the Mach-Zender coupler of a_2 and b_2 .

Utilizing the outputs of the Mach-Zender coupler, a receiver can be constructed to demodulate a single optical Differential Phase Shift Keyed (DPSK) signal as shown in Figure 1.2. The outputs of the Mach-Zender coupler are followed by a photodetector (PD) to convert the optical signal to an electrical current by an amount proportional to the

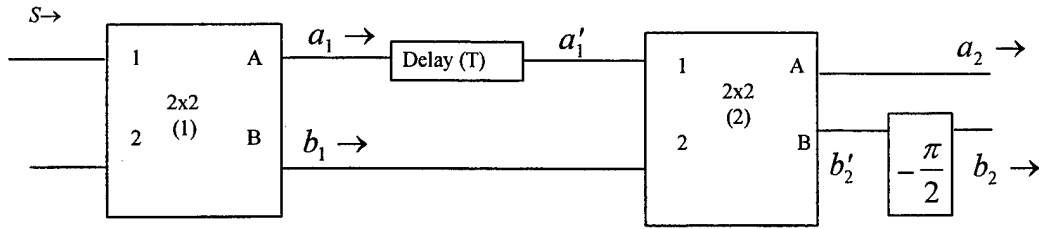

Figure 1.1 The Mach-Zender Coupler

responsivity (\mathcal{R}) of the photodiode. This current signal is further amplified by a transimpedance amplifier of gain Z_0 and input to an integrator over one period (T). The energy of the two channels is then compared and a symbol (“1” or “0”) is chosen based on the channel with the greatest energy.

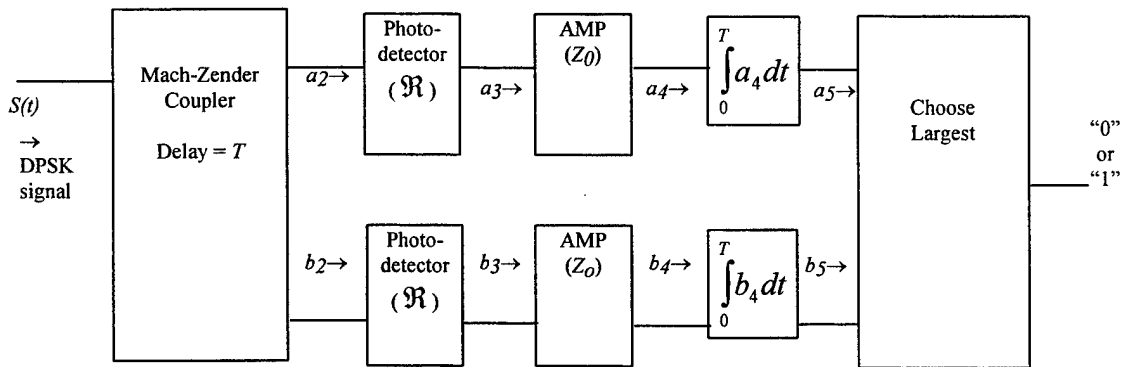

Figure 1.2 Demodulation of DPSK Signal Using Mach-Zender Coupler

By combining multiple couplers with varying delays (e.g. T and $2T$), a Code Shift Keyed (CSK) signal employing Hadamard-Walsh coding could be demodulated. This orthogonally coded signal would allow multiple stations to use a single fiber optic line simultaneously as is currently being done using Wavelength Division Multiplexing (WDM). With WDM, however, there is a significant cost in creating very sensitive filters necessary to demodulate the signal [Ref. 1]. Figure 1.3 shows a system using multiple Mach-Zender couplers that is capable of decoding four Hadamard-Walsh coded signals.

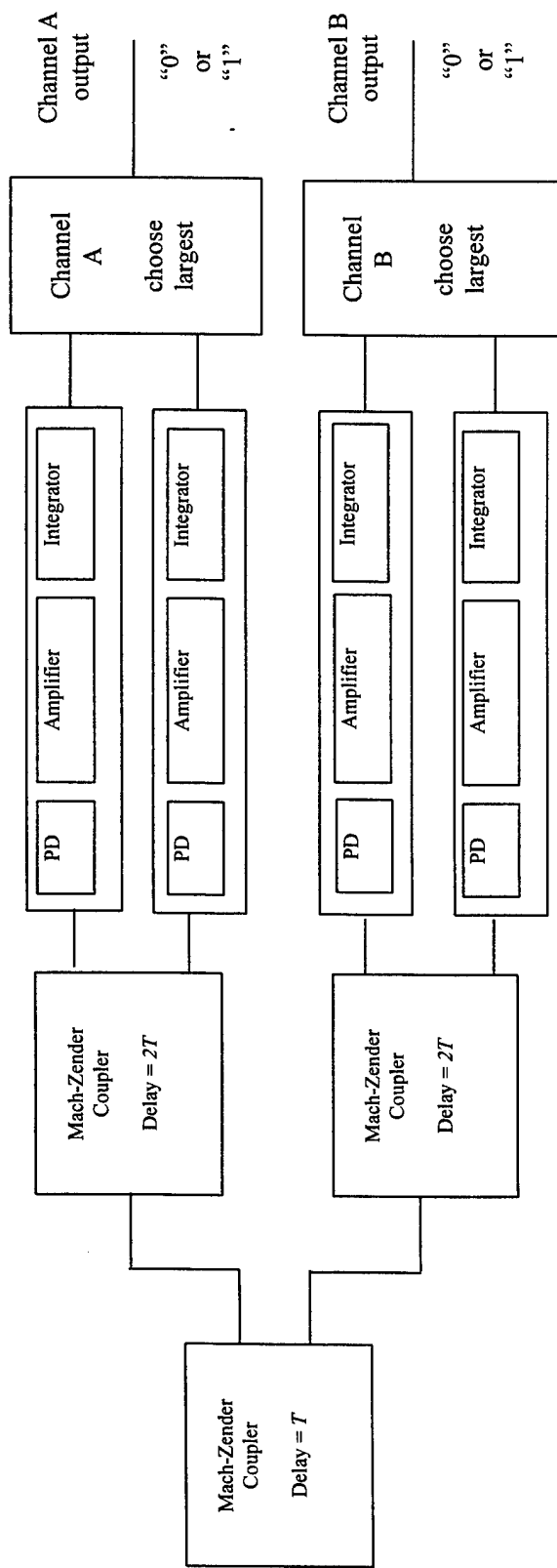

Figure 1.3 Multiple Stage Mach-Zender Coupler Receiver

By increasing the number of Mach-Zender coupler stages, this receiver can be constructed to demultiplex increasingly complex Hadamard-Walsh coded signals.

In Chapter II, the theory behind the Mach-Zender coupler will be discussed, and from this theory, a mathematical model of the coupler will be developed. This model will include both time and frequency domains. Chapter III will use the Mach-Zender mathematical model of Chapter II to develop a single user DPSK encoded optical receiver. From this DPSK receiver a probability of bit-error will be determined based on the signal-to-noise ratio at the receiver. Chapter IV will then propose a multi-user Code Shift Keyed (CSK) optical receiver and develop the bit error rate for the multi-user receiver. Chapter V will then compare the theoretical results of the bit error rate versus signal-to-noise ratio in the single user receiver with those obtained by a computer model of the receiver. Chapter V will continue with the computer model to conduct a sensitivity analysis of the single user receiver. Finally, Chapter VI will discuss the conclusion of this thesis and present some areas for future research with these optical receivers.

II. DEVELOPMENT OF A MATHEMATICAL MODEL FOR THE MACH-ZENDER COUPLER

A. OVERVIEW OF MACH-ZENDER COUPLER

In the following analysis, a mathematical description of the Mach-Zender coupler, as has been previously developed at the Naval Postgraduate School [Ref. 2], will be reviewed. This model will be used to analyze the demodulation of an optical DPSK signal using a single Mach-Zender coupler.

As previously described, the Mach-Zender Coupler consists of two 2x2 optical couplers, a delay line of some delay nT where n is an integer and T is the period of the signal, and a device to provide a phase shift of $-\pi/2$ radians. Port 1 of the first coupler is the input and Port A of the second coupler and the output port of the final phase shift element are the outputs.

The delay of the Mach-Zender coupler can be accomplished by inserting a length of fiber equivalent to the desired delay. Heinbaugh [Ref. 2] proposed using a 2x2 coupler with a single input and a single output to obtain a $\pi/2$ phase shift. This mathematical model will use a $-\pi/2$ phase shift.

The input signal is defined as $s(t)$ in the time domain and $S(f)$ is its Fourier transform in the frequency domain. As the review in this chapter will show, the output in the time domain is $s(t-T)-s(t)$ for port A of the second coupler and $s(t-T)+s(t)$ for the output of the phase shift element. This is as illustrated in Figure 2.1.

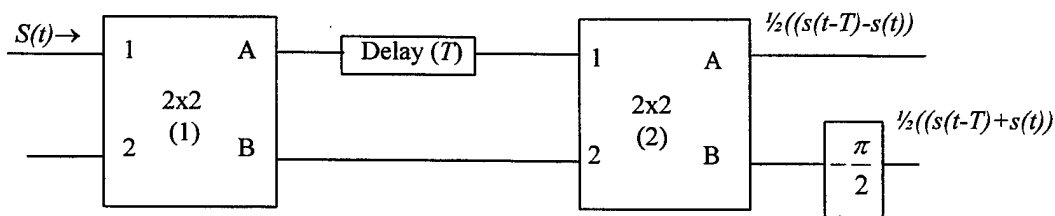

Figure 2.1 Signal Throughput of the Mach-Zender Coupler

B. DEVELOPING A MATHEMATICAL MODEL

In this section each element of the Mach-Zender coupler will be analyzed mathematically and an expression relating to that particular element's effect on $s(t)$ will be developed.

1. Coupler Analysis

The optical coupler, Figure 2.2, has four ports labeled 1, 2, A and B. Each port can be used as an input or an output .

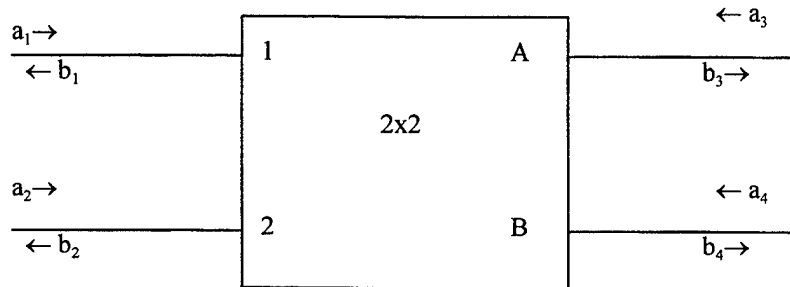

Figure 2.2 Optical 2x2 Coupler

Let the frequency domain inputs of the 2x2 coupler of Figure 2.2 be described by the following vectors \tilde{a} and \tilde{b} :

$$\tilde{a} = \begin{bmatrix} a_1 \\ a_2 \\ a_3 \\ a_4 \end{bmatrix} \quad \tilde{b} = \begin{bmatrix} b_1 \\ b_2 \\ b_3 \\ b_4 \end{bmatrix} . \quad (2.1)$$

The input vector \tilde{a} and the output vector \tilde{b} are related by the scattering matrix S defined as follows [Ref. 3]:

$$S = \begin{bmatrix} 0 & 0 & 1 & j \\ 0 & 0 & j & 1 \\ 1 & j & 0 & 0 \\ j & 1 & 0 & 0 \end{bmatrix} \quad (2.2)$$

where

$$\tilde{b} = S\tilde{a} \quad (2.3)$$

$$\begin{bmatrix} \tilde{b}_1 \\ \tilde{b}_2 \\ \tilde{b}_3 \\ \tilde{b}_4 \end{bmatrix} = \frac{1}{\sqrt{2}} \begin{bmatrix} 0 & 0 & 1 & j \\ 0 & 0 & j & 1 \\ 1 & j & 0 & 0 \\ j & 1 & 0 & 0 \end{bmatrix} \begin{bmatrix} \tilde{a}_1 \\ \tilde{a}_2 \\ \tilde{a}_3 \\ \tilde{a}_4 \end{bmatrix}. \quad (2.4)$$

Equation 2.2 can be simplified if the matrices of Equation 2.4 are partitioned as shown below:

$$\begin{bmatrix} \tilde{b}_1 \\ \tilde{b}_2 \\ \tilde{b}_3 \\ \tilde{b}_4 \end{bmatrix} = \frac{1}{\sqrt{2}} \begin{bmatrix} 0 & 0 & \vdots & 1 & j \\ 0 & 0 & \vdots & j & 1 \\ \vdots & \vdots & \ddots & 0 & 0 \\ j & 1 & \vdots & 0 & 0 \end{bmatrix} \begin{bmatrix} \tilde{a}_1 \\ \tilde{a}_2 \\ \tilde{a}_3 \\ \tilde{a}_4 \end{bmatrix}. \quad (2.5)$$

After partitioning, Equation 2.5 can be rewritten as follows:

$$\begin{bmatrix} \tilde{b}_1 \\ \tilde{b}_2 \end{bmatrix} = \frac{1}{\sqrt{2}} \begin{bmatrix} 1 & j \\ j & 1 \end{bmatrix} \begin{bmatrix} \tilde{a}_3 \\ \tilde{a}_4 \end{bmatrix} = \begin{bmatrix} (\tilde{a}_3 + j\tilde{a}_4) / \sqrt{2} \\ (j\tilde{a}_3 + \tilde{a}_4) / \sqrt{2} \end{bmatrix} \quad (2.6a)$$

$$\begin{bmatrix} \tilde{b}_3 \\ \tilde{b}_4 \end{bmatrix} = \frac{1}{\sqrt{2}} \begin{bmatrix} 1 & j \\ j & 1 \end{bmatrix} \begin{bmatrix} \tilde{a}_1 \\ \tilde{a}_2 \end{bmatrix} = \begin{bmatrix} (\tilde{a}_1 + j\tilde{a}_2) / \sqrt{2} \\ (j\tilde{a}_1 + \tilde{a}_2) / \sqrt{2} \end{bmatrix}. \quad (2.6b)$$

Observe that in the ideal 2x2 optical coupler, no part of the input signal is reflected back to the input ports. Specifically, when the only inputs are \tilde{a}_1 and \tilde{a}_2 , the outputs are confined to \tilde{b}_3 and \tilde{b}_4 as in Equation 2.6b. That is \tilde{b}_3 and \tilde{b}_4 consist of only in-phase and $\pi/2$ phase-shifted components of \tilde{a}_1 and \tilde{a}_2 .

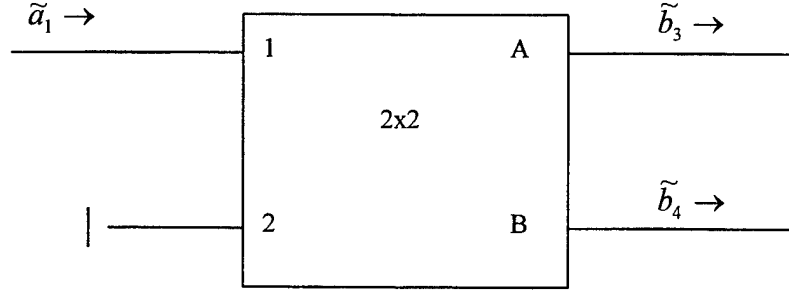

Figure 2.3 Single Input 2x2 Coupler

To apply this result to a practical use of the Mach-Zender coupler, consider Figure 2.3 in which one input signal is applied to one input port, and the remaining port is terminated. Equation 2.6b now reduces to become:

$$\begin{bmatrix} \tilde{b}_3 \\ \tilde{b}_4 \end{bmatrix} = \begin{bmatrix} \tilde{a}_1 / \sqrt{2} \\ j\tilde{a}_1 / \sqrt{2} \end{bmatrix} = \begin{bmatrix} \tilde{a}_1 / \sqrt{2} \\ e^{j\pi/2} \tilde{a}_1 / \sqrt{2} \end{bmatrix}. \quad (2.7)$$

We see that the input \tilde{a}_1 is decreased by a factor of $1/\sqrt{2}$ at ports A and B and the output at port B is shifted in phase by $\pi/2$ radians from the input.

2. Delay Element Analysis

As shown in Figure 1.1 the delay element represents a time shift of T in the time domain which corresponds to multiplication by $e^{j2\pi fT}$ in the frequency domain. The input and output of the delay element can be modeled in the time domain as in Figure 2.4 with the output $\tilde{a}'_1 = \tilde{a}_1 e^{j2\pi fT}$ in the frequency domain.

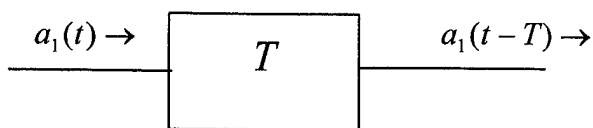

Figure 2.4 Time delay element

3. Phase Shift Element Analysis

The phase shift of the Mach-Zender Coupler can be accomplished using a 2x2 coupler with only one input and one output. The result would be a signal shifted by $\pi/2$ radians. For this model, a phase shift of $-\pi/2$ radians was assumed. The phase shift can be modeled in the frequency domain as in Figure 2.5.

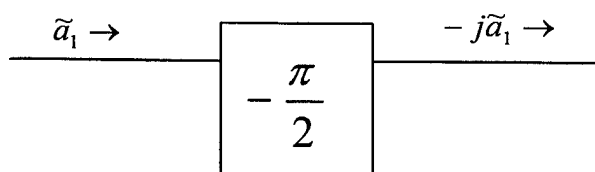

Figure 2.5 Phase Shift Element

C. INPUT SIGNAL ANALYSIS

Using the preceding development, the function of the Mach-Zender coupler can now be completely described. Consider an input signal, $s(t)$, applied to an input port of the Mach-Zender coupler. The unused input port (2) is terminated. Let $S(f)$ be the Fourier transform of $s(t)$. The signal can be applied to a Mach-Zender coupler as shown in Figure 2.6.

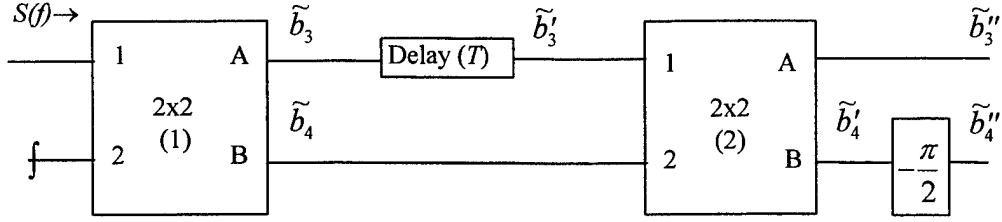

Figure 2.6 Input Signal Through Mach-Zender Coupler

Using Equation 2.7 the output of the first coupler becomes

$$\begin{bmatrix} \tilde{b}_3 \\ \tilde{b}_4 \end{bmatrix} = \begin{bmatrix} S(f) / \sqrt{2} \\ jS(f) / \sqrt{2} \end{bmatrix}. \quad (2.8)$$

After the delay line the inputs to the second coupler are obtained by applying the delay illustrated in Figure 2.4. The inputs to the second coupler are:

$$\begin{bmatrix} \tilde{b}_3' \\ \tilde{b}_4' \end{bmatrix} = \begin{bmatrix} e^{-j2\pi f T} & 0 \\ 0 & 1 \end{bmatrix} \begin{bmatrix} S(f) / \sqrt{2} \\ jS(f) / \sqrt{2} \end{bmatrix} = \begin{bmatrix} S(f)e^{-j2\pi f T} / \sqrt{2} \\ jS(f) / \sqrt{2} \end{bmatrix}. \quad (2.9)$$

The outputs of the second coupler, \tilde{b}_3'' and \tilde{b}_4'' , are obtained by applying Equation 2.6b with \tilde{b}_3' and \tilde{b}_4' as the inputs. The following result is obtained:

$$\begin{bmatrix} \tilde{b}_3'' \\ \tilde{b}_4'' \end{bmatrix} = \frac{1}{\sqrt{2}} \begin{bmatrix} 1 & j \\ j & 1 \end{bmatrix} \begin{bmatrix} S(f)e^{-j2\pi f T} / \sqrt{2} \\ jS(f) / \sqrt{2} \end{bmatrix} = \begin{bmatrix} 1/2(S(f)e^{-j2\pi f T} - S(f)) \\ j/2(S(f)e^{-j2\pi f T} - S(f)) \end{bmatrix}. \quad (2.10)$$

The addition of the $-\pi/2$ phase shift gives the final result in the frequency domain as:

$$\begin{bmatrix} \tilde{b}_3'' \\ \tilde{b}_4'' \end{bmatrix} = \begin{bmatrix} 1 & 0 \\ 0 & -j \end{bmatrix} \begin{bmatrix} 1/2(S(f)e^{-j2\pi f T} - S(f)) \\ j/2(S(f)e^{-j2\pi f T} - S(f)) \end{bmatrix} = \frac{1}{2} \begin{bmatrix} (S(f)e^{-j2\pi f T} - S(f)) \\ (S(f)e^{-j2\pi f T} + S(f)) \end{bmatrix}. \quad (2.11)$$

By taking the inverse Fourier transform of Equation 2.11 the time domain result is obtained:

$$\begin{bmatrix} b_3''(t) \\ b_4''(t) \end{bmatrix} = \frac{1}{2} \begin{bmatrix} s(t-T) - s(t) \\ s(t-T) + s(t) \end{bmatrix}. \quad (2.12)$$

By multiplying the matrices used to represent the phase shift, delay and two couplers (Equation 2.13), we can derive a general equation (Equation 2.14(a), 2.14(b)) where the output of the Mach-Zender coupler can be readily determined from the inputs \tilde{a}_1 and \tilde{a}_2 ,

$$\begin{bmatrix} \tilde{b}_3'' \\ \tilde{b}_4'' \end{bmatrix} = \begin{bmatrix} 1 & 0 \\ 0 & -j \end{bmatrix} \frac{1}{\sqrt{2}} \begin{bmatrix} 1 & j \\ j & 1 \end{bmatrix} \begin{bmatrix} e^{-j2\pi fT} & 0 \\ 0 & 1 \end{bmatrix} \frac{1}{\sqrt{2}} \begin{bmatrix} 1 & j \\ j & 1 \end{bmatrix} \begin{bmatrix} \tilde{a}_1 \\ \tilde{a}_2 \end{bmatrix} \quad (2.13)$$

Phase Shift 2nd Coupler delay 1st Coupler

$$\begin{bmatrix} \tilde{b}_3'' \\ \tilde{b}_4'' \end{bmatrix} = \frac{1}{2} \begin{bmatrix} (e^{-j2\pi fT} - 1) & (je^{-j2\pi fT} + j) \\ (e^{-j2\pi fT} + 1) & (je^{-j2\pi fT} - j) \end{bmatrix} \begin{bmatrix} \tilde{a}_1 \\ \tilde{a}_2 \end{bmatrix} \quad (2.14a)$$

$$\begin{bmatrix} \tilde{b}_3'' \\ \tilde{b}_4'' \end{bmatrix} = \frac{1}{2} \begin{bmatrix} \tilde{a}_1(e^{-j2\pi fT} - 1) + \tilde{a}_2 j(e^{-j2\pi fT} + 1) \\ \tilde{a}_1(e^{-j2\pi fT} + 1) + \tilde{a}_2(e^{-j2\pi fT} - 1) \end{bmatrix}. \quad (2.14b)$$

D. SUMMARY

In this chapter the optical 2x2 coupler was shown to combine the signals of its input ports, split the signal, and send the result to the output port such that both signals leave the coupler simultaneously. It was determined that if only one input port was used then no part of the input signal was reflected back. It was also shown that the outputs from the Mach-Zender coupler are $(S(f)e^{-j2\pi fT} - S(f))/2$ and $(S(f)e^{-j2\pi fT} + S(f))/2$

in the frequency domain or, equivalently, $(s(t-T) - s(t))/2$ and $(s(t-T) + s(t))/2$ in the time domain.

In the next chapter a receiver will be proposed using the Mach-Zender coupler that is capable of processing a DPSK encoded signal. Using the results of Chapter II, the signal will be traced through the receiver and its strength relative to the receiver noise will be analyzed. Finally, a probability of bit-error, P_b , will be developed based on these results.

III. DPSK DEMODULATION ANALYSIS

A. INPUT DPSK SIGNAL

In Chapter I, an optical receiver capable of decoding a DPSK encoded signal was proposed (Figure 3.1). Chapter II then developed a mathematical model (Equation 2.12) of the Mach-Zender coupler to be used in this optical receiver. With these results, the next step is to analyze the input of a DPSK signal and assess the receiver performance versus the input signal-to-noise ratio (SNR).

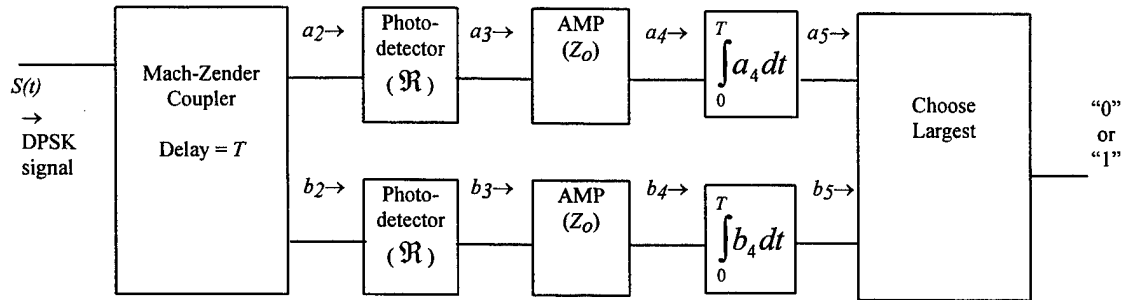

Figure 3.1 Optical DPSK Receiver

A given DPSK signal will be in one of two forms (over a period of $2T$ where T is the period of the input signal) depending on the information bit being transmitted. For a bit "1" being sent where $0 \leq t < 2T$, the signal will be:

$$S_1(t) = \pm Ap_T(t-T) \cos(2\pi f_c t + \theta_0) \mp Ap_T(t) \cos(2\pi f_c t + \theta_0). \quad (3.1)$$

For a bit "0" being sent where $0 \leq t < 2T$, the signal will be:

$$S_0(t) = \pm Ap_T(t-T) \cos(2\pi f_c t + \theta_0) \pm Ap_T(t) \cos(2\pi f_c t + \theta_0) \quad (3.2)$$

where f_c is a multiple of $1/T$ and $p_T(t-iT)$ with i an integer is defined as:

$$p_T(t-iT) = \begin{cases} 1 & iT \leq t < (i+1)T \\ 0 & \text{otherwise.} \end{cases} \quad (3.3)$$

Due to the symmetry of the signal, an analysis of an input 1 or 0 will produce the same results. To simplify the calculations an input of 0 (Equation 3.2) will be considered.

B. RECEIVER ANALYSIS

1. Output of Mach-Zender Coupler

In Chapter II, the output of the Mach-Zender Coupler was determined in Equation 2.12. Applying Equation 2.12 to the input signal, given the transmission of a 0 (Equation 3.2), the following output is obtained where $T \leq t < 2T$:

$$\begin{bmatrix} a_2(t) \\ b_2(t) \end{bmatrix} = \frac{1}{2} \begin{bmatrix} 0 \\ \pm A \cos(2\pi f_c t + \theta_0) \pm A \cos(2\pi f_c t + \theta_0) \end{bmatrix}. \quad (3.4)$$

Simplifying this expression yields:

$$\begin{bmatrix} a_2(t) \\ b_2(t) \end{bmatrix} = \begin{bmatrix} 0 \\ \pm A \cos(2\pi f_c t + \theta_0) \end{bmatrix} \quad (3.5)$$

which are the outputs of the Mach-Zender coupler given an optical DPSK input signal.

2. Photodetector Analysis

The next stage of the receiver is an optical photodetector (PD) which converts the optical signal into an electrical current signal. The PD provides an output current equivalent to the input peak power ($P=A^2/2$) multiplied by the responsivity (\mathfrak{R}) plus the shot noise, $\eta_s(t)$ [Ref. 4].

Taking our input from the Mach-Zender coupler (Equation 3.5) and applying it to our PD gives the following signal in the receiver over the interval where $T \leq t < 2T$:

$$\begin{bmatrix} a_3(t) \\ b_3(t) \end{bmatrix} = \begin{bmatrix} \eta_{s_a}(t) \\ \Re(A^2 / 2) + \eta_{s_b}(t) \end{bmatrix}. \quad (3.6)$$

It is important to note at this stage that the shot noise produced by the two PD devices ($\eta_{s_a}(t)$ and $\eta_{s_b}(t)$) are independent of one another.

3. Amplifier Analysis

The next stage of the receiver consists of a transimpedance amplifier with gain Z_0 . Along with a gain to the input signal, this amplifier will introduce additive white gaussian noise (AWGN), $\eta_{amp}(t)$, to the signal. In order to simplify the understanding of noise in the receiver a summation of total noise will be necessary.

Both the amplifier noise, $\eta_{amp}(t)$, and the shot noise, $\eta_{s_a}(t)$ and $\eta_{s_b}(t)$, are modeled as AWGN with zero mean. If the total noise in each individual channel is $\eta(t)$ then:

$$\eta(t) = \eta_{amp}(t) + \eta_s(t). \quad (3.7)$$

Therefore, the noise content of each channel following the amplifier stage will be $\eta_a(t)$ and $\eta_b(t)$ with a power spectral density (PSD) of N_0 . Again, the noise in each channel will be independent of the noise in the other channel.

Given this simplifying assumption, the output of the amplifier is simply the input (Equation 3.6) plus the amplifier noise ($\eta_{amp}(t)$) multiplied by the amplifier gain (Z_0):

$$\begin{bmatrix} a_4(t) \\ b_4(t) \end{bmatrix} = \begin{bmatrix} Z_0 \eta_a(t) \\ Z_0 (\Re A^2 / 2 + \eta_b(t)) \end{bmatrix}. \quad (3.8)$$

4. Integrator Analysis

The next step in the analysis is to take the amplifier output (Equation 3.8) and run it through the integrator. This will give us:

$$\begin{bmatrix} a_5(t) \\ b_5(t) \end{bmatrix} = \begin{bmatrix} \int_0^T [Z_0 \eta_a(t)] dt \\ \int_0^T [(Z_0 \mathcal{R}A^2 / 2) + (Z_0 \eta_b(t))] dt \end{bmatrix} \quad (3.9)$$

which will simplify to:

$$\begin{bmatrix} a_5(t) \\ b_5(t) \end{bmatrix} = \begin{bmatrix} \int_0^T [Z_0 \eta_a(t)] dt \\ Z_0 \mathcal{R}A^2 T / 2 + \int_0^T [Z_0 \eta_b(t)] dt \end{bmatrix}. \quad (3.10)$$

To continue with the analysis of the integrator output the statistical nature of the signal at this point will be examined. Signal $a_5(t)$ is defined as follows:

$$a_5(t) = \bar{a}_5 + N_a(t) \quad (3.11)$$

where $\bar{a}_5 = 0$ and $N_a(t) = \int_0^T [Z_0 \eta_a(t)] dt$. Since $N_a(t)$ consists of a constant multiplied by zero mean AWGN, its mean is also zero. Therefore \bar{a}_5 represents the mean and $N_a(t)$ represents the noise.

Similarly if $b_5(t)$ is defined as:

$$b_5(t) = \bar{b}_5 + N_b(t) \quad (3.12)$$

where $\bar{b}_5 = Z_0 \mathcal{R}A^2 T / 2$ and $N_b(t) = \int_0^T [Z_0 \eta_b(t)] dt$, then \bar{b}_5 represents the mean and $N_b(t)$ represents the noise.

Next, for a gaussian random variable such as our zero mean AWGN defined by $N_a(t)$ and $N_b(t)$, the variance (σ^2) is defined by:

$$\sigma_{N_a}^2 = \sigma_{N_b}^2 = Z_0^2 N_0 T. \quad (3.13)$$

Now that the mean and variance of $a_s(t)$ and $b_s(t)$ has been determined, an analysis of the decision process to choose the signal sent can be undertaken.

5. Decision Variable Analysis

With the mean and variance of the signals to be input to the decision element determined, an examination as the probability of an error in signal reception can begin. A symbol "0" was assumed to be sent to our device initially, therefore an error will have occurred if the symbol "1" is chosen as the output. This probability of choosing a "1" when a "0" is sent, $\Pr\{1|0\}$, will be equivalent to the magnitude of the signal in channel a being greater than the signal in channel b given that a "0" was sent or $\Pr\{a_s > b_s | 0\}$.

If a new variable, Y , is defined where:

$$Y = b_s - a_s \quad (3.14)$$

then it is apparent that:

$$\Pr\{a_s > b_s | 0\} = \Pr\{Y < 0 | 0\}. \quad (3.15)$$

From the analysis of the integrator output it was determined that a_s and b_s are both independent gaussian random variables, and therefore Y , as the difference of a_s and b_s , is also a gaussian random variable. Consequently the mean of Y or \bar{Y} can be obtained as follows:

$$\bar{Y} = \bar{b}_s - \bar{a}_s = Z_0 \Re A^2 T / 2. \quad (3.16)$$

Similarly the variance of Y (σ_Y^2) can also be obtained as follows:

$$\sigma_Y^2 = \sigma_{N_a}^2 + \sigma_{N_b}^2 = Z_0^2 N_0 T + Z_0^2 N_0 T = 2Z_0^2 N_0 T. \quad (3.17)$$

$\Pr\{1|0\}$ or $\Pr\{Y < 0|0\}$ can be defined by the probability density function of Y as follows:

$$\Pr\{Y < 0|0\} = \int_{-\infty}^0 f_y(y|0) dy \quad (3.18)$$

where the probability density function, $f_y(y|0)$, for a gaussian random variable is defined as:

$$f_y(y|0) = \frac{1}{\sqrt{2\pi}\sigma_y} \exp\left[-\frac{((y - \bar{Y})^2)}{2\sigma_y^2}\right]. \quad (3.19)$$

Substituting Equation 3.19 into Equation 3.18 gives:

$$\Pr\{Y < 0|0\} = \int_{-\infty}^0 f_y(y|0) dy = \int_{-\infty}^0 \frac{1}{\sqrt{2\pi}\sigma_y} \exp\left[-\frac{((y - \bar{Y})^2)}{2\sigma_y^2}\right] dy. \quad (3.20)$$

If a new variable x is defined such that $x = -\frac{(y - \bar{Y})}{\sigma_y}$ then $dx = -\frac{dy}{\sigma_y}$. Using this new variable to substitute into Equation 3.20 gives:

$$\Pr\{Y < 0|0\} = \frac{1}{\sqrt{2\pi}\sigma_y} \int_{-\infty}^{\bar{Y}/\sigma_y} \exp\left[-\frac{x^2}{2}\right] (-\sigma_y dx) = \frac{1}{\sqrt{2\pi}} \int_{\bar{Y}/\sigma_y}^{\infty} \exp\left[-\frac{x^2}{2}\right] dx. \quad (3.21)$$

Equation 3.21 is now in the same format as the Q function, $Q(z)$, where $z = \frac{\bar{Y}}{\sigma_y}$.

Therefore:

$$\begin{aligned} \Pr\{1|0\} &= Q\left(\frac{\bar{Y}}{\sigma_y}\right) = Q\left(\frac{Z_0 \Re A^2 T / 2}{Z_0 \sqrt{2N_0 T}}\right) \\ &= Q\left(\frac{1}{2} \Re A^2 \sqrt{\frac{T}{2N_0}}\right). \end{aligned} \quad (3.22)$$

C. PROBABILITY OF BIT ERROR

The probability of bit error, P_b , for this receiver can be determined as:

$$P_b = \Pr(1) \times \Pr\{0|1\} + \Pr(0) \times \Pr\{1|0\}. \quad (3.23)$$

If a "1" or a "0" is equiprobable (i.e., $\Pr(1) = \Pr(0)$) and, if by symmetry $\Pr\{0|1\} = \Pr\{1|0\}$, then substituting Equation 3.22 into Equation 3.23:

$$P_b = Q\left(\frac{1}{2} \Re A^2 \sqrt{\frac{T}{2N_0}}\right). \quad (3.24)$$

Further, if the peak power (P) is defined as $P=A^2/2$ then Equation 3.24 will simplify to:

$$P_b = Q\left(\Re P \sqrt{\frac{T}{2N_0}}\right). \quad (3.25)$$

Defining the voltage signal-to-noise ratio (SNR) as:

$$SNR = \frac{\bar{Y}}{\sigma_y} = \frac{1}{2} \Re A^2 \sqrt{\frac{T}{2N_0}} = \Re P \sqrt{\frac{T}{2N_0}} \quad (3.26)$$

then P_b becomes:

$$P_b = Q(SNR). \quad (3.27)$$

Figure 3.2 shows this dependence, which illustrates the rapid decline in bit error rate as the signal-to-noise ratio exceeds 4 dB.

D. SUMMARY

In this chapter a mathematical model for a single user DPSK encoded optical receiver was developed using the analysis of the Mach-Zender coupler from Chapter II.

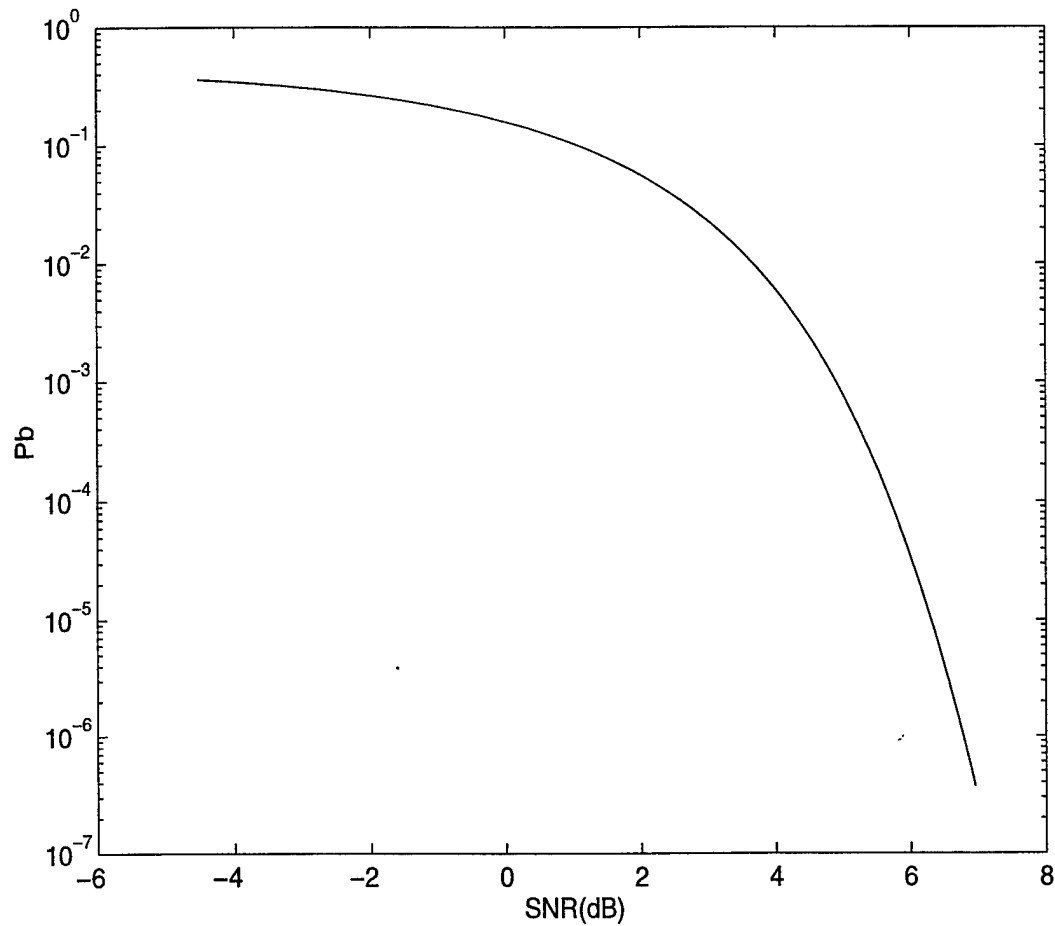

Figure 3.2 P_b vs. SNR

From this model a relationship of bit-error rate versus signal-to-noise ratio was then developed.

In Chapter IV, a mathematical model of a multi-user CSK optical receiver will be developed in a very similar manner to the development in this chapter for a DPSK receiver. Again as in this chapter, that model will be used to determine the performance (i.e., P_b vs. SNR) of the CSK multi-user receiver.

IV. CSK DEMODULATION ANALYSIS

A. INTRODUCTION

The preceding chapter developed a probability of bit error for a DPSK demodulated signal. A DPSK demodulated signal implies that only one user can send in information in the optical fiber at a time. In order to allow multiple users to utilize the fiber simultaneously, the signal demodulation must be modified. As was introduced in Chapter I, a Code Shift Keyed (CSK) signal employing Hadamard-Walsh coding can be used to allow multiple users on a fiber simultaneously.

The Hadamard-Walsh code is a straightforward method of creating multiple orthogonal signals. The Hadamard-Walsh basic 2x2 matrix is:

$$\begin{bmatrix} 1 & 1 \\ 1 & -1 \end{bmatrix} \quad (4.1)$$

Observe that the correlation of the first row vector with the second row vector is zero. The matrix of Equation 4.1 can be built upon to create additional orthogonal vectors as follows:

$$\begin{bmatrix} \begin{bmatrix} 1 & 1 \\ 1 & -1 \end{bmatrix} & \begin{bmatrix} 1 & 1 \\ 1 & -1 \end{bmatrix} \\ \begin{bmatrix} 1 & 1 \\ 1 & -1 \end{bmatrix} & -\begin{bmatrix} 1 & 1 \\ 1 & -1 \end{bmatrix} \end{bmatrix} \quad (4.2)$$

It is apparent that the individual elements of the 2x2 Hadamard-Walsh matrix are used to multiply the entire 2x2 matrix and Equation 4.2 can be written as:

$$\begin{bmatrix} 1 & 1 & 1 & 1 \\ 1 & -1 & 1 & -1 \\ 1 & 1 & -1 & -1 \\ 1 & -1 & -1 & 1 \end{bmatrix} \quad (4.3)$$

Again observe that each row vector is orthogonal (i.e., has a zero correlation) to all others.

The 4x4 matrix of Equation 4.3 consists of four orthogonal vectors and can be applied to a system in which two bits or two users' information must be decided simultaneously. It is this matrix that will be used to design an optical receiver and develop the probability of bit error for two users on the same fiber simultaneously.

The design of the receiver will be the same as that proposed in Chapter I and is shown in Figure 4.1.

B. INPUT CSK HADAMARD-WALSH ENCODED SIGNAL

A given two-user CSK Hadamard-Walsh encoded signal, $S(t)$, will be comprised of the sum of two orthogonal signals, one each from channel A and channel B. Therefore:

$$S(t) = S_A(t) + S_B(t). \quad (4.4)$$

$S(t)$ will exist over a bit time of $T=4T'$ where T' is the period of the input signal. Further:

$$T' = \frac{T}{4} \quad (4.5)$$

where T was defined in chapter three as the period of a DPSK signal. The possible signals from channels A and B where $0 \leq t < 4T'$ are:

$$\begin{aligned} S_{1B}(t) = & +Ap_{T'}(t-3T')\cos(2\pi f_c t + \theta_0) + Ap_{T'}(t-2T')\cos(2\pi f_c t + \theta_0) \\ & + Ap_{T'}(t-T')\cos(2\pi f_c t + \theta_0) + Ap_{T'}(t)\cos(2\pi f_c t + \theta_0) \end{aligned} \quad (4.6)$$

$$\begin{aligned} S_{1A}(t) = & +Ap_{T'}(t-3T')\cos(2\pi f_c t + \theta_0) - Ap_{T'}(t-2T')\cos(2\pi f_c t + \theta_0) \\ & + Ap_{T'}(t-T')\cos(2\pi f_c t + \theta_0) - Ap_{T'}(t)\cos(2\pi f_c t + \theta_0) \end{aligned} \quad (4.7)$$

$$\begin{aligned} S_{0B}(t) = & +Ap_{T'}(t-3T')\cos(2\pi f_c t + \theta_0) + Ap_{T'}(t-2T')\cos(2\pi f_c t + \theta_0) \\ & - Ap_{T'}(t-T')\cos(2\pi f_c t + \theta_0) - Ap_{T'}(t)\cos(2\pi f_c t + \theta_0) \end{aligned} \quad (4.8)$$

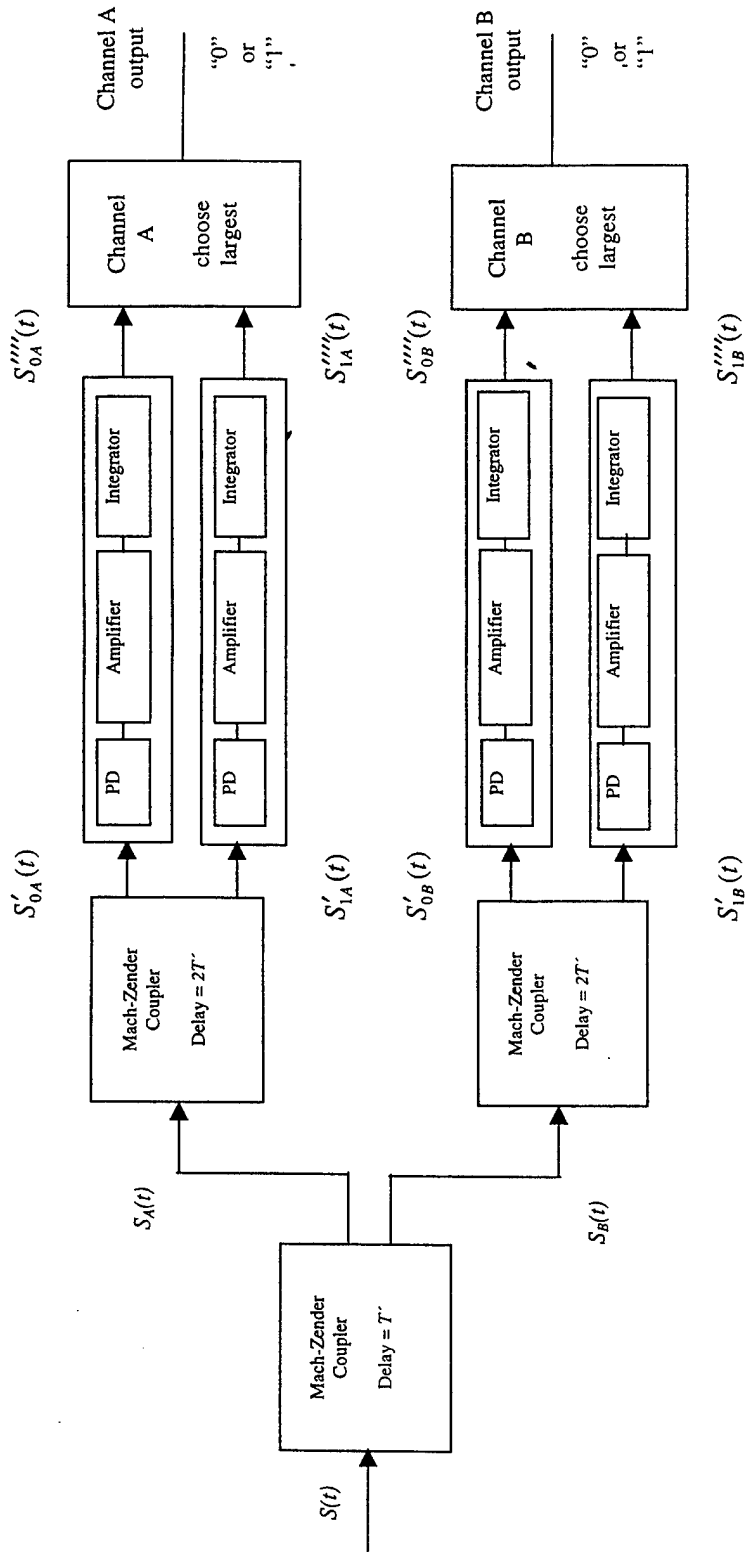

Figure 4.1 Multiple Stage Mach-Zender Coupler Receiver

$$S_{0A}(t) = +Ap_{T'}(t-3T')\cos(2\pi f_c t + \theta_0) - Ap_{T'}(t-2T')\cos(2\pi f_c t + \theta_0) \\ - Ap_{T'}(t-T')\cos(2\pi f_c t + \theta_0) + Ap_{T'}(t)\cos(2\pi f_c t + \theta_0) \quad (4.9)$$

where the S subscript refers to the bit transmitted and the channel it was transmitted from, respectively. For example, $S_{1A}(t)$ refers to the channel A component of $S(t)$ in which a 1 was transmitted for channel A, and $S_{0B}(t)$ refers to the channel B component of $S(t)$ for which a zero was transmitted for channel B. The $p_{T'}(t-iT')$ term is defined as it was in Chapter III (Equation 3.3). The frequency f_c is a multiple of $1/T'$.

Again due to the symmetry of the signal an analysis of all possible inputs is not necessary, as each will produce the same result. Also, as each signal in channel A is orthogonal to all signals in channel B, there will be no interference between channel A and channel B signals in $S(t)$. To aid in the development of a probability of bit error, P_b , an input of a 1 in channel A and a 0 in channel B will be considered. This input corresponds to Equations 4.6 and 4.7 respectively and the input signal will be:

$$S(t) = S_{1A}(t) + S_{0B}(t). \quad (4.10)$$

C. RECEIVER ANALYSIS

1. Output of First Stage Mach-Zender Coupler

In this multistage receiver the first stage is identical to that analyzed in Chapter III (Figure 3.1), substituting T' for T . Again as in Chapter III the output of the first stage is determined by applying Equation 2.12 to the input signal, Equation 4.9. Given a 1 in channel A and a 0 in channel B the following first stage output is obtained where $T' \leq t < 4T'$:

$$\begin{bmatrix} S_A(t) \\ S_B(t) \end{bmatrix} = \frac{1}{2} \cos(2\pi f_c t + \theta_0) \begin{bmatrix} -2Ap_{T'}(t-3T') + 2Ap_{T'}(t-2T') - 2Ap_{T'}(t-T') \\ + 2Ap_{T'}(t-3T') - 2Ap_{T'}(t-T') \end{bmatrix}. \quad (4.11)$$

A detailed derivation of this output is contained in Appendix A.

2. Output of Second Stage Mach-Zender Couplers

The second-stage couplers are designed with a $2T'$ delay variable and consequently the analysis of their outputs is different than that of the first stage. However, with only a slight modification, a variation of Equation 2.12 can be used to describe their outputs. Specifically for a delay of $2T'$ Equation 2.12 can be rewritten as follows:

$$\begin{bmatrix} a(t) \\ b(t) \end{bmatrix} = \frac{1}{2} \begin{bmatrix} s(t-2T') - s(t) \\ s(t-2T') + s(t) \end{bmatrix}. \quad (4.12)$$

Applying Equation 4.12 to the input of the second stage, Equation 4.11, the following output is obtained where $3T' \leq t < 4T'$:

$$\begin{bmatrix} S'_{0A}(t) \\ S'_{1A}(t) \\ S'_{0B}(t) \\ S'_{1B}(t) \end{bmatrix} = \frac{1}{2} \begin{bmatrix} 0 \\ 1/2(4A \cos(2\pi f_c t + \theta_0)) \\ 1/2(-4A \cos(2\pi f_c t + \theta_0)) \\ 0 \end{bmatrix} \quad (4.13)$$

which can be simplified to:

$$\begin{bmatrix} S'_{0A}(t) \\ S'_{1A}(t) \\ S'_{0B}(t) \\ S'_{1B}(t) \end{bmatrix} = \begin{bmatrix} 0 \\ A \cos(2\pi f_c t + \theta_0) \\ -A \cos(2\pi f_c t + \theta_0) \\ 0 \end{bmatrix}. \quad (4.14)$$

These equations represents the output at the second stage Mach-Zender couplers given an optical multiplexed CSK Hadamard-Walsh encoded signal.

2. Photodetector Analysis

The remainder of the receiver for each channel is identical to the DPSK receiver analyzed in Chapter III; therefore, the analysis will be similar. In the next stage of the receiver the optical photodetector (PD) converts the optical signal into an electrical signal.

The PD provides an output current equivalent to the input power ($P=A^2/2$) multiplied by the responsivity, \mathfrak{R} , plus the shot noise, $\eta_s(t)$.

Taking our input from the Mach-Zender couplers (Equation 4.13) and applying it to our PD gives the following signals in the receiver over the interval $3T' \leq t < 4T'$:

$$\begin{bmatrix} S''_{0A}(t) \\ S''_{1A}(t) \\ S''_{0B}(t) \\ S''_{1B}(t) \end{bmatrix} = \begin{bmatrix} \eta_{s_{0A}}(t) \\ \mathfrak{R}(A^2/2) + \eta_{s_{1A}}(t) \\ \mathfrak{R}(A^2/2) + \eta_{s_{0B}}(t) \\ \eta_{s_{1B}}(t) \end{bmatrix}. \quad (4.15)$$

It is important to again note at this stage that the shot noise produced by the all the PD devices are independent of one another.

3. Amplifier Analysis

The next stage of the receiver, as was the case in Chapter III, consists of a transimpedance amplifier with gain Z_0 . Along with a gain to the input signal, this amplifier will introduce AWGN, $\eta_{amp}(t)$, to the signal. As was the case in the analysis of the DPSK receiver the total noise in each channel will be summed. Since both the amplifier noise, $\eta_{amp}(t)$, and the shot noise, $\eta_s(t)$, are AWGN with zero mean, the total noise in each individual channel is $\eta(t)$ and :

$$\eta(t) = \eta_{amp}(t) + \eta_s(t). \quad (4.16)$$

The noises, $\eta_{0A}(t)$, $\eta_{1A}(t)$, $\eta_{0B}(t)$, and $\eta_{1B}(t)$, all have a power spectral density (PSD) of N_0 and the noise in each channel is independent of the noise in the other channels.

Given this simplifying assumption the output of the amplifier is simply the input (Equation 4.14) plus the amplifier noise, $\eta_{amp}(t)$, multiplied by the amplifier gain, Z_0 and can be written as:

$$\begin{bmatrix} S''''_{0A}(t) \\ S''''_{1A}(t) \\ S''''_{0B}(t) \\ S''''_{1B}(t) \end{bmatrix} = \begin{bmatrix} Z_0 \eta_{0A}(t) \\ Z_0 (\Re A^2 / 2 + \eta_{1A}(t)) \\ Z_0 (\Re A^2 / 2 + \eta_{0B}(t)) \\ Z_0 \eta_{1B}(t) \end{bmatrix}. \quad (4.17)$$

4. Integrator Analysis

The next step in the analysis is to take the amplifier output (Equation 4.17) and run it through the integrator. This will give us:

$$\begin{bmatrix} S''''''_{0A}(t) \\ S''''''_{1A}(t) \\ S''''''_{0B}(t) \\ S''''''_{1B}(t) \end{bmatrix} = \begin{bmatrix} \int_{3T'}^{4T'} [Z_0 \eta_{0A}(t)] dt \\ \int_{3T'}^{4T'} [Z_0 (\Re A^2 / 2 + \eta_{1A}(t))] dt \\ \int_{3T'}^{4T'} [Z_0 (\Re A^2 / 2 + \eta_{0B}(t))] dt \\ \int_{3T'}^{4T'} [Z_0 \eta_{1B}(t)] dt \end{bmatrix} \quad (4.18)$$

which will simplify to:

$$\begin{bmatrix} S''''''_{0A}(t) \\ S''''''_{1A}(t) \\ S''''''_{0B}(t) \\ S''''''_{1B}(t) \end{bmatrix} = \begin{bmatrix} \int_{3T'}^{4T'} [Z_0 \eta_{0A}(t)] dt \\ Z_0 \Re A^2 T' / 2 + \int_{3T'}^{4T'} [Z_0 \eta_{1A}(t)] dt \\ Z_0 \Re A^2 T' / 2 + \int_{3T'}^{4T'} [Z_0 \eta_{0B}(t)] dt \\ \int_{3T'}^{4T'} [Z_0 \eta_{1B}(t)] dt \end{bmatrix}. \quad (4.19)$$

To greatly simplify the analysis at this point, notice the similarity of the integrator output defined in Equation 4.19 to that of the DPSK receiver integrator output defined in Equation 3.10. Specifically, the information plus noise channels in both cases ($S''''''_{1A}(t)$,

$S_{0B}''''(t)$ and $b_5(t)$) are identical as are the noise-only channels ($S_{1B}''''(t)$, $S_{0A}''''(t)$, and $a_5(t)$). Therefore, the statistical nature of the CSK receiver integrator output can be summarized as:

$$S_{0A} = \bar{S}_{0A} + N_{0A} \quad (4.20)$$

$$S_{1A} = \bar{S}_{1A} + N_{1A} \quad (4.21)$$

$$S_{0B} = \bar{S}_{0B} + N_{0B} \quad (4.22)$$

$$S_{1B} = \bar{S}_{1B} + N_{1B} \quad (4.23)$$

where the mean of each channel can be described as \bar{S}_{0A} and \bar{S}_{1B} (which are both equal to zero) and $\bar{S}_{1A} = \bar{S}_{0B} = Z_0 \Re A^2 T' / 2$. Further, the variances of each channel have identical characteristics, and as in Chapter III, each channel represents a gaussian random variable. Therefore the variance in each channel can be defined as:

$$\sigma_N^2 = Z_0^2 N_0 T' \quad (4.24)$$

Now that the mean and variance for each channel has been determined, an analysis of the decision process can be undertaken.

5. Decision Variable Analysis

With the determination of the mean and variance of the signals to be input to the decision element, an examination of the probability of an error in signal reception can begin. Due to the symmetry of the signal the probability of a bit error in channel A, $P_b\{A\}$, is equal to the probability of a bit error in channel B, $P_b\{B\}$. Therefore an error in channel A will be considered and the result will be the same for channel B. If a symbol 1 was sent in channel A, an error will occur if the symbol 0 is chosen. This probability of choosing a 0 when a 1 is sent in channel A, $\Pr_A\{0|1\}$, will be equivalent to the magnitude of the signal S_{0A} being larger than the signal S_{1A} . A new variable is defined as follows:

$$Y = S_{1A} - S_{0A}. \quad (4.25)$$

It is apparent that to make an incorrect decision Y must be less than zero and therefore:

$$\Pr_A \{0|1\} = \Pr_A \{S_{0A} > S_{1A}|1\} = \Pr_A \{Y < 0|1\}. \quad (4.26)$$

In Chapter III a probability of bit-error was developed (Equations 3.16 to 3.22) relating one information plus noise channel to one noise-only channel. Similarly, in this CSK receiver, channel A is almost identical to the result derived in Chapter III, with the only difference being that the period in channel A is now T' vice T . Using the result obtained in Equation 3.24 and substituting T' for T gives:

$$\Pr_A \{0|1\} = Q \left(\frac{1}{2} \mathfrak{R}A^2 \sqrt{\frac{T'}{2N_0}} \right). \quad (4.27)$$

Now using the definition of T' , Equation 4.5, and rewriting in terms of T :

$$\Pr_A \{0|1\} = Q \left(\frac{1}{2} \mathfrak{R}A^2 \sqrt{\frac{T}{4 \times 2N_0}} \right). \quad (4.28)$$

D. PROBABILITY OF BIT ERROR

The probability of bit error for this receiver can be determined as:

$$P_b = P_b \{A\} = P_b \{B\}. \quad (4.29)$$

Since the probability of an error in channel A equals the probability of an error in channel B, P_b can be generalized by considering channel A only. In channel A:

$$P_b \{A\} = \Pr_A(1) \times \Pr_A \{0|1\} + \Pr_A(0) \times \Pr_A \{1|0\}. \quad (4.30)$$

If a 1 or a 0 in channel A is equiprobable (i.e., $Pr_A(1)=Pr_A(0)=1/2$) and if by symmetry $Pr_A\{0|1\}=Pr_A\{1|0\}$ then by substituting Equation 4.28 into Equation 4.30:

$$P_b = P_b\{A\} = Q\left(\frac{1}{2}\Re A^2 \sqrt{\frac{T}{4 \times 2N_0}}\right). \quad (4.31)$$

If the power (P) is defined as $P=A^2/2$ then Equation 4.31 will simplify to:

$$P_b = Q\left(\frac{1}{2}\Re P \sqrt{\frac{T}{2N_0}}\right) \quad (4.32)$$

and if the signal-to-noise ratio (SNR) is defined as it was in Equation 3.25, then P_b becomes:

$$P_b = Q\left(\frac{SNR}{2}\right) \quad (4.33)$$

This result implies a 3 dB degradation in performance when compared to the result for DPSK, Equation 3.26. Figure 4.2 shows a plot of the theoretical performance of the DPSK and the CSK receivers and at bit-error rates below about 3×10^{-3} the DPSK receiver is degraded by 3 dB.

E. SUMMARY

This chapter built upon the development of the single-user DPSK receiver from Chapter III and has shown that the performance of a two-user CSK optical receiver is 3 dB less than that of a single user DPSK optical receiver. The next step in the study in the use of the Mach-Zender coupler in an optical receiver will be to create a computer model of the simple DPSK receiver and obtain performance data from the model. If the model performance data closely resembles the theoretical data derived in Chapter III then various components of the model can be altered to conduct a sensitivity analysis of the optical

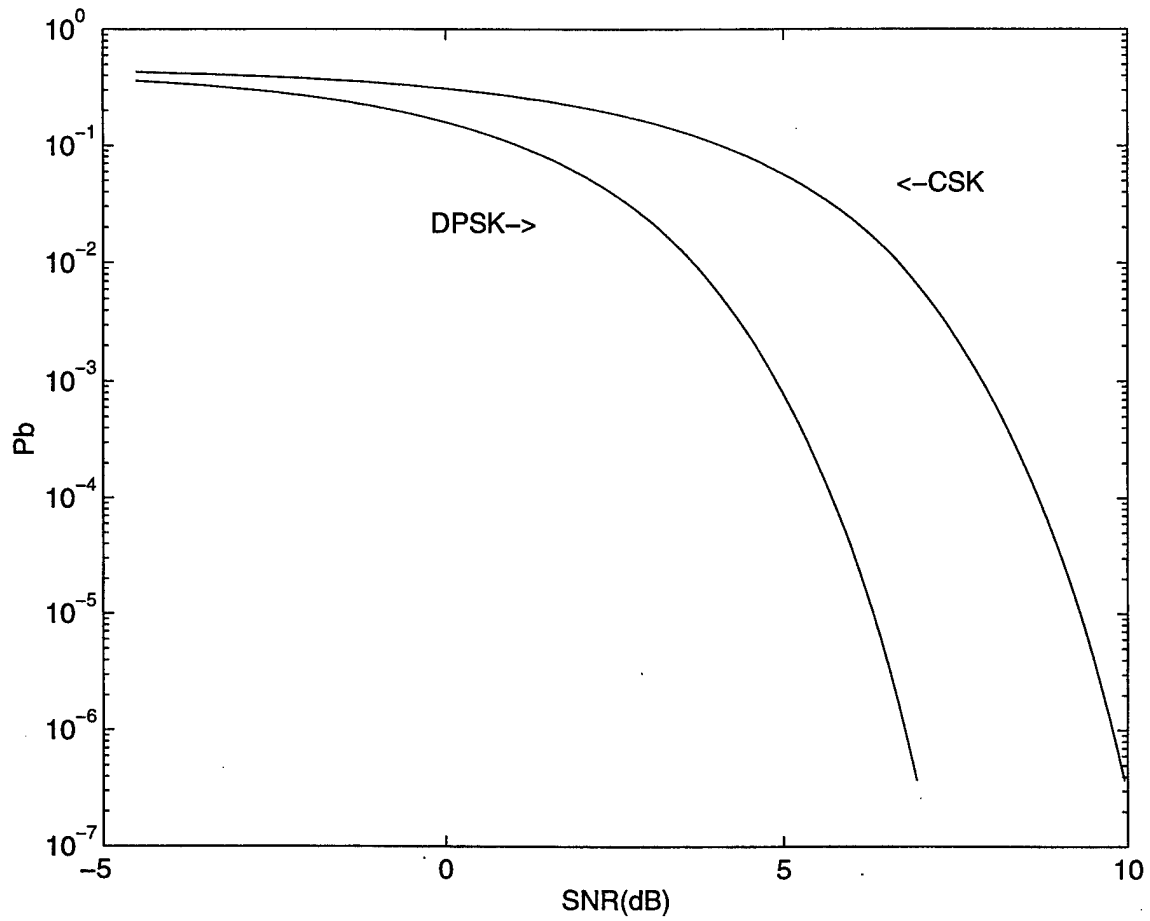

Figure 4.2 P_b vs. SNR (theoretical DPSK and CSK receivers)

DPSK receiver. Chapter V will discuss the construction of the computer model and show the results of the sensitivity analysis.

V. SIMULATION AND SENSITIVITY ANALYSIS

A. SIMULATION

1. Design Approach

The third chapter developed the theoretical probability of bit error for a DPSK optical signal demodulated using the Mach-Zender coupler. If a simulation of the optical and electrical receiver components can be constructed using MATLAB code and the statistical outcomes of the simulated receiver at various signal-to-noise ratios accumulated, then a comparison of the simulated performance to the theoretical will confirm the accuracy of the model.

2. Mach-Zender Coupler Simulation Construction

Previous work at the Naval Postgraduate School [Ref. 2] has extensively studied the physical characteristics of the Mach-Zender coupler. Given this understanding of the coupler, a modularized model of the coupler was constructed in MATLAB code. Appendix B contains a copy of the code for each module. Each element of the coupler was modeled as an individual function with varying operational characteristics.

The optical 2x2 couplers were designed with a variable input scattering matrix. This allows for varying amounts of coupling of the input signal(s) into the output signals. In addition, a delay element was constructed capable of creating any desired delay onto an input signal.

The phase shift element was modeled as another 2x2 coupler as was proposed in the phase shift element analysis of Chapter II. A drawback of using another 2x2 coupler to phase shift the signal is the 3 dB attenuation of the signal by the coupler. In order to balance the final output power of both channels (\tilde{b}_3' and \tilde{b}_4'' of Figure 2.6) an attenuation element was inserted in the non-phase shifted output. As with the other modules the amount of attenuation was a controlled variable.

3. Electrical Receiver Element Simulation

The next stage of the proposed DPSK optical signal receiver converts the demodulated optical output of the Mach-Zender coupler into an electrical signal for processing to obtain a digital output signal as described in Chapter III. Each electrical component was again designed as a module with varying inputs.

The photodetector can apply the responsivity (\mathfrak{R}) and add additive white gaussian noise to its output. The transimpedance amplifier uniformly amplifies the signal and also adds additive white gaussian noise. The integrator integrates the signal over one period. The relative strengths of the signal in channel A and channel B are then compared to make a decision of a "1" or a "0".

4. Statistical Analysis

The MATLAB model of the receiver was repeatedly run at various SNR to obtain the probability of bit error for specific SNR. The simulated results and the theoretical results are shown in Figure 5.1. The simulated results differed by about 4/10 of a dB from the theoretical. This indicates that the MATLAB model was accurate.

With the accuracy of the model confirmed, the model can be used to vary the operation of various components and investigate the sensitivity of receiver performance to less than ideal components. Specifically, the amount of delay and the phase shift were altered to non-ideal values and new receiver probability of bit errors were compiled.

B. SENSITIVITY ANALYSIS

1. Delay Error

In building the Mach-Zender coupler the delay element was implemented by inserting an extra length of fiber equal in length to one bit period. At 100 Mbps Heinbaugh [Ref. 2] showed that tolerances of $\pm 0.5\%$ were achievable. Inserting a delay error of 0.5% into the MATLAB model showed no difference in P_b vs. SNR. In order to

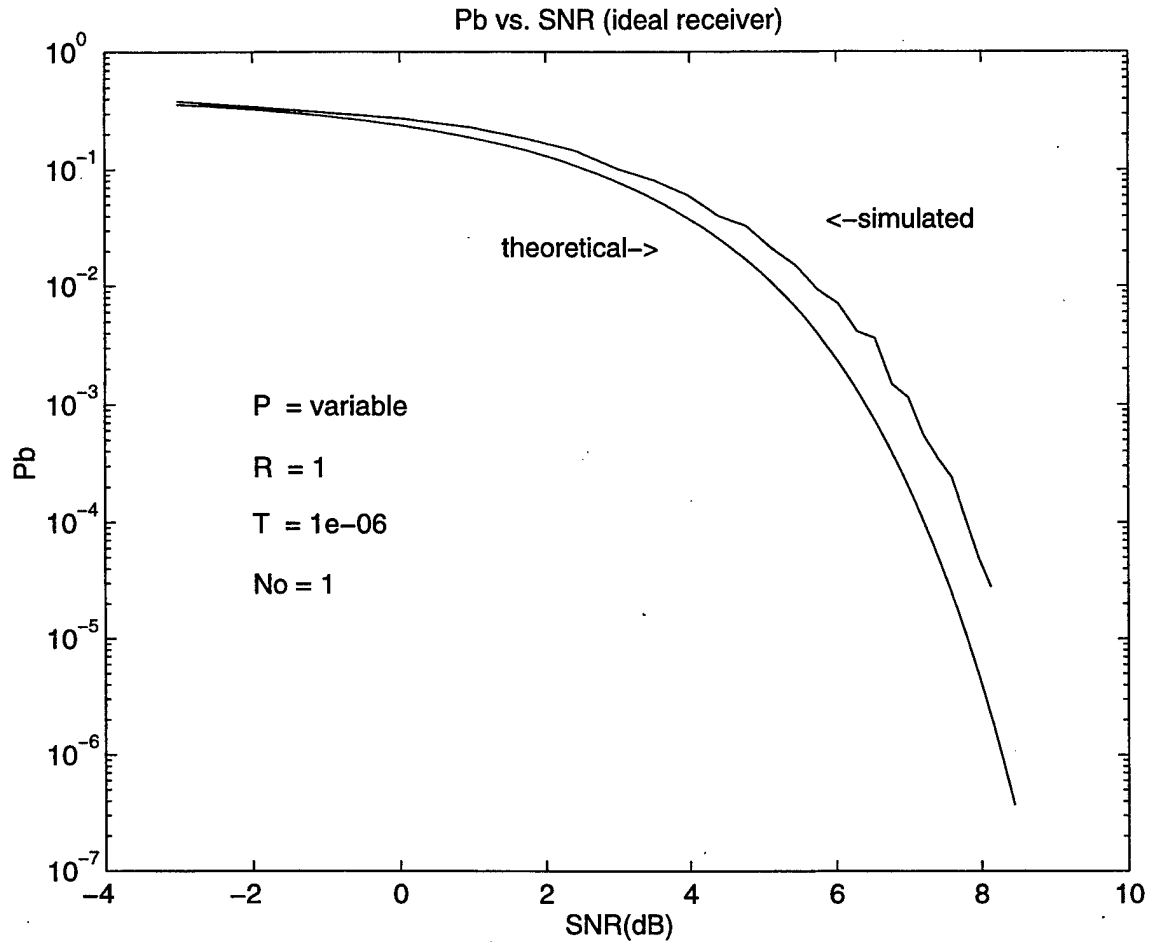

Figure 5.1 P_b vs. SNR (ideal receiver)

acquire measurable data delay, errors of 5%, 10% and 20% were introduced into the model. The results are shown in Figure 5.2. With 5% delay error the required SNR for a specific P_b increased one half of a dB. A 10% delay error resulted in over a 3 dB degradation in performance. At 20% delay error the receiver remained a random number generator (i.e., $P_b=0.5$) up through a 13 dB SNR.

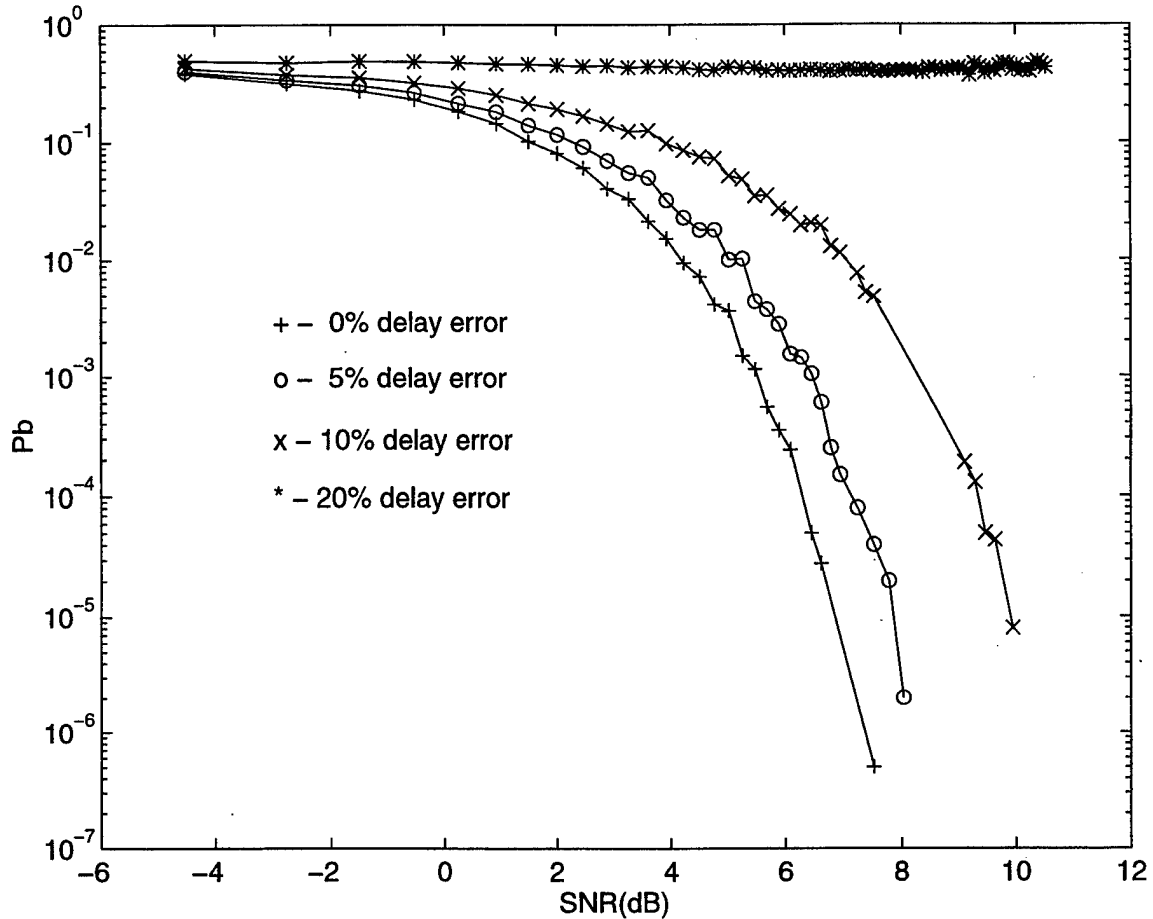

Figure 5.2 P_b vs. SNR (simulated delay error)

1. Phase Shift Error

The phase shift error is defined by the ability of the 2x2 coupler to change the phase of the input signal while keeping attenuation as close to 3 dB as possible. In the simulation, attenuation was maintained at 3 dB but the effects of phase delay errors of 10° and 30° were investigated. The results are shown in Figure 5.3.

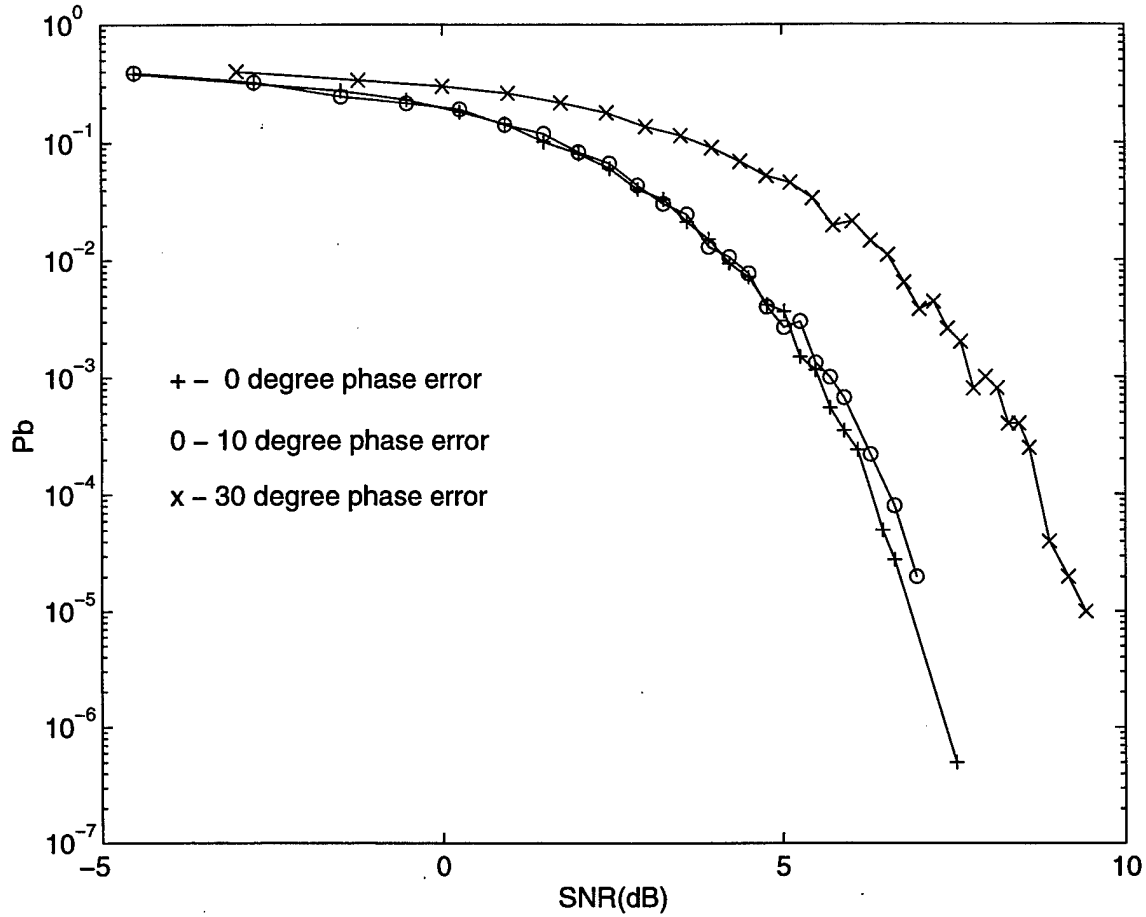

Figure 5.3 P_b vs. SNR (phase shift error)

For a 10° phase shift error receiver performance degradation was minimal and almost zero. For a 30° error the receiver degradation was about 2 dB.

C. SUMMARY

This chapter reviewed the construction of a computer model in MATLAB code to simulate the DPSK optical receiver. The performance of the model was compared to that predicted by the theoretical results obtained in Chapter III and the model performance closely resembled theoretical performance. Having established the accuracy of the model,

the model was then used to determine the sensitivity of the DPSK optical receiver given errors in delay and phase shift elements. Chapter VI will summarize the modeled results and discuss areas for future reasearch regarding the use of the Mach-Zender coupler in an optical receiver.

VI. CONCLUSION

A. DISCUSSION OF RESULTS

This thesis proposed the use of the Mach-Zender coupler in a single-user optical receiver and mathematically illustrated its theoretical implementation. Next, building on this implementation, the theory supporting the use of the Mach-Zender coupler to demodulate multiplexed fiber-optic signals was developed and also illustrated mathematically. From this analysis, we created a computer simulation of the single-user optical receiver. Comparing the performance of the simulation with the expected theoretical performance established the accuracy of the model. With an accurate computer simulation developed, the characteristics of the model were then altered to investigate the sensitivities of the optical receiver to non-ideal components.

Chapter IV showed theoretically how the optical receiver could be expanded to demodulate a two-user multiplexed fiber optic signal. A two-user optical receiver experienced a 3-dB degradation in performance as compared to the single-user optical receiver proposed in Chapter III. The receiver of Chapter IV could be extended to increase the number of users multiplexed on a single optic-fiber by extending the number of Mach-Zender coupler stages with varying delays.

Chapter V discussed the receiver simulation using a MATLAB model, and its performance closely followed theory. This indicated that the model was accurate and that adjusting parameters of the model to more closely resemble an actual Mach-Zender coupler should give reasonable results in the sensitivity analysis.

The sensitivity analysis conducted with the model showed only one-half dB degradation from a 5% delay error. As was discussed in the Chapter V, a 5% error was well above the 0.5% error achieved in the construction of the Mach-Zender coupler by Heinbaugh [Ref. 2]. Therefore, the effects of delay error due to construction on receiver performance should be minimal.

The sensitivity analysis then varied the phase shift error up to 30° and a degradation of less than 2 dB was experienced. A phase shift error of 30° is large; larger phase shift errors are unlikely. Therefore, this receiver design does not appear to be sensitive to probable errors in phase shift.

This sensitivity analysis, conducted using the MATLAB model, indicates that this is a realizable receiver with a strong potential of simultaneously demodulating multiple

signals in one fiber optic line. If this method proves to be feasible, it could provide a cost-effective alternative to demodulating multiplexed fiber-optic signals over the current technique using Wavelength Division Multiplexing.

B. FUTURE RESEARCH

Future research on the feasibility of using the Mach-Zender coupler should focus on:

1. Using the existing Mach-Zender couplers to build a DPSK optical-signal receiver in order to confirm the sensitivity analysis already conducted with the MATLAB model.
2. Constructing a CSK optical-signal receiver to investigate the reality of demodulating information from two or more users simultaneously on one fiber.

**APPENDIX A: ANALYSIS OF OUTPUT OF TWO MACH-ZENDER
COUPLERS FOR CSK ENCODED SIGNAL**

1. SIGNAL INPUTS

The following two signals are input to the receiver of Figure 4.1 as $S(t)$:

$$S_{1A}(t) = +Ap_{T'}(t - 3T')\cos(2\pi f_c t + \theta_0) - Ap_{T'}(t - 2T')\cos(2\pi f_c t + \theta_0) \\ + Ap_{T'}(t - T')\cos(2\pi f_c t + \theta_0) - Ap_{T'}(t)\cos(2\pi f_c t + \theta_0) \quad (\text{A.1})$$

$$S_{0B}(t) = +Ap_{T'}(t - 3T')\cos(2\pi f_c t + \theta_0) + Ap_{T'}(t - 2T')\cos(2\pi f_c t + \theta_0) \\ - Ap_{T'}(t - T')\cos(2\pi f_c t + \theta_0) - Ap_{T'}(t)\cos(2\pi f_c t + \theta_0) \quad (\text{A.2})$$

due to the orthogonality of the signals and superposition each signal can be considered separately and the end results summed.

2. CHANNEL A INPUT ANALYSIS

First consider the signal for channel A. To aid in analysis, $\cos(2\pi f_c t + \theta_0)$ will be factored out and left out of the equation until the end result is obtained. The output of the first coupler with a delay of T' for the channel A input will be described as $S_A^A(t)$ and $S_B^A(t)$. The superscript refers to the contributing input channel and the subscript refers to the output channel. Therefore from $T' \leq t < 4T'$ the output is:

$$S_A^A(t) = \frac{1}{2} [S_{1A}(t-T') - S_{1A}(t)] = \\ \frac{1}{2} [+Ap_{T'}(t - 4T') - Ap_{T'}(t - 3T') + Ap_{T'}(t - 2T') - Ap_{T'}(t - T') \\ - [+Ap_{T'}(t - 3T') - Ap_{T'}(t - 2T') + Ap_{T'}(t - T') - Ap_{T'}(t)]] \\ = \frac{1}{2} \times 2 \times [-Ap_{T'}(t - 3T') + Ap_{T'}(t - 2T') - Ap_{T'}(t - T')] \quad (\text{A.3})$$

$$\begin{aligned}
S_B^A(t) &= \frac{1}{2} [S_{IA}(t-T') + S_{IA}(t)] = \\
&\frac{1}{2} [+Ap_{T'}(t-4T') - Ap_{T'}(t-3T') + Ap_{T'}(t-2T') - Ap_{T'}(t-T') \\
&\quad + [+Ap_{T'}(t-3T') - Ap_{T'}(t-2T') + Ap_{T'}(t-T') - Ap_{T'}(t)]] \\
&= \frac{1}{2} \times 2 \times [0] = 0
\end{aligned} \tag{A.4}$$

Equation A.4 is zero and can be disregarded. Therefore, applying the result of Equation A.3 to the input of the second stage coupler with a delay of $2T'$ gives an output from $3T' \leq t < 4T'$ of:

$$\begin{aligned}
S_{0A}^A(t) &= \frac{1}{2} [S_A(t-T') - S_A(t)] = \\
&\frac{1}{2} [-Ap_{T'}(t-5T') + Ap_{T'}(t-4T') - Ap_{T'}(t-3T') \\
&\quad - [-Ap_{T'}(t-3T') + Ap_{T'}(t-2T') - Ap_{T'}(t-T')]] \\
&= \frac{1}{2} \times 2 \times [0] = 0
\end{aligned} \tag{A.5}$$

$$\begin{aligned}
S_{1A}^A(t) &= \frac{1}{2} [S_A(t-T') + S_A(t)] = \\
&\frac{1}{2} [-Ap_{T'}(t-5T') + Ap_{T'}(t-4T') - Ap_{T'}(t-3T') \\
&\quad + [-Ap_{T'}(t-3T') + Ap_{T'}(t-2T') - Ap_{T'}(t-T')]] \\
&= \frac{1}{2} \times 2 \times [-Ap_{T'}(t-3T')]
\end{aligned} \tag{A.6}$$

Equations A.5 and A.6 represent the output of the second stage coupler for channel A.

3. CHANNEL B INPUT ANALYSIS

Next consider the signal for channel B. To aid in analysis, $\cos(2\pi f_c t + \theta_0)$ will be factored out and left out of the equation until the end result is obtained. Therefore at the output of the first coupler with a delay of T' for the channel B input from $T' \leq t < 4T'$ is:

$$\begin{aligned}
 S_A^B(t) &= \frac{1}{2} [S_{OB}(t-T') - S_{OB}(t)] = \\
 &\frac{1}{2} [+Ap_{T'}(t-4T') + Ap_{T'}(t-3T') - Ap_{T'}(t-2T') - Ap_{T'}(t-T')] \\
 &\quad - [+Ap_{T'}(t-3T') + Ap_{T'}(t-2T') - Ap_{T'}(t-T') - Ap_{T'}(t)] \\
 &= \frac{1}{2} \times 2 \times [-Ap_{T'}(t-2T')] \tag{A.7}
 \end{aligned}$$

$$\begin{aligned}
 S_B^B(t) &= \frac{1}{2} [S_{IA}(t-T') + S_{IA}(t)] = \\
 &\frac{1}{2} [+Ap_{T'}(t-4T') + Ap_{T'}(t-3T') - Ap_{T'}(t-2T') - Ap_{T'}(t-T')] \\
 &\quad + [+Ap_{T'}(t-3T') + Ap_{T'}(t-2T') - Ap_{T'}(t-T') - Ap_{T'}(t)] \\
 &= \frac{1}{2} \times 2 \times [+Ap_{T'}(t-3T') - Ap_{T'}(t-T')] \tag{A.8}
 \end{aligned}$$

where the superscript refers to the contributing input channel and the subscript refers to the output channel. Equation A.7 has only one term and that term and a $2T'$ delayed version of that term will be out of range of $3T' \leq t < 4T'$ and can be disregarded. Equation A.8 can be applied to the input of the second stage coupler with a delay of $2T'$ gives an output from $3T' \leq t < 4T'$ of:

$$\begin{aligned}
 S_{OB}^B(t) &= \frac{1}{2} [S_B(t-T') - S_B(t)] = \\
 &\frac{1}{2} [+Ap_{T'}(t-5T') - Ap_{T'}(t-3T')] \\
 &\quad - [+Ap_{T'}(t-3T') - Ap_{T'}(t-T')] \\
 &= \frac{1}{2} \times 2 \times [-Ap_{T'}(t-3T')] \tag{A.9}
 \end{aligned}$$

$$\begin{aligned}
S_{1B}^{B'}(t) &= \frac{1}{2} [S_B(t-T') + S_B(t)] = \\
&\frac{1}{2} [+Ap_{T'}(t-5T') - Ap_{T'}(t-3T') \\
&\quad + [+Ap_{T'}(t-3T') - Ap_{T'}(t-T')]] \\
&= \frac{1}{2} \times 2 \times [0] = 0.
\end{aligned} \tag{A.10}$$

Equations A.9 and A.10 represent the output of the second stage coupler for channel B.

4. OUTPUTS

The output of the first coupler in equation 4.11 is as follows:

$$\begin{bmatrix} S_A(t) \\ S_B(t) \end{bmatrix} = \begin{bmatrix} S_A^A(t) + S_A^B(t) \\ S_B^A(t) + S_B^B(t) \end{bmatrix} \tag{A.11}$$

and consequently the output of the second coupler in equation 4.14 is as follows:

$$\begin{bmatrix} S'_{0A}(t) \\ S'_{1A}(t) \\ S'_{0B}(t) \\ S'_{1B}(t) \end{bmatrix} = \begin{bmatrix} S_{0A}^{A'}(t) \\ S_{1A}^{A'}(t) \\ S_{0B}^{B'}(t) \\ S_{1B}^{B'}(t) \end{bmatrix}. \tag{A.12}$$

Substituting Equations A.5, A.6, A.9, A.10 into equation A.12 will give the result listed in Equation 4.14.

APPENDIX B: MATLAB SIMULATION PROGRAMS

This appendix contains the MATLAB code for the various modules of the DPSK optical receiver model.

1. OPTICAL DPSK RECEIVER

```
% set input paramters
f = 1e6;           % frequency
T = 1/f;          % signal period
Td = T;           % length of delay
SM = [1,j,j,1];  % scattering matrix
L = 3;            % attenuation (dB)
R = 1;            % responsivity
No = 1;           % noise PSD
Zo = 1;           % amplifier gain
PWR = [8000];     % power levels
t = linspace(0,T); % time intervals for one signal

% load number of runs
n=2000000;

% query users for number of runs
%n = input('enter number of simulations to run>> ');

for p=1:length(PWR)

    A = sqrt(PWR(p));

    % initialize data matrices
    xmtbit = zeros(1,n+1);
    rcvbit = zeros(1,n);

    % initial synchronization signal to receiver
    S1=A*cos(2*pi*f.*t);
    phase = 1;

    % create 1st data signal
    [S2,xmtbit(1)] = onechxmt(f,phase);
    S2 = A*S2;

    % update phase setting
```

```

if xmtbit(1) == 1
    phase = -1*phase;
end

for i = 1:n
    % create 1st data signal
    [S3,xmtbit(i+1)] = onechxmt(f,phase);
    S3 = A * S3;

    % update phase
    if xmtbit(i+1) == 1
        phase = -1*phase;
    end

    % create next input signal
    S =[S3,S2,S1];

    % input S to Mach-Zender coupler
    [xa,xb] = mzcoup(S,T,Td,SM,L);

    % input MZ output to RCVR
    [rcvbit(i)] = rcvr(xa,xb,R,Zo,No,T);

    % progress signal to next period
    S1 = S2;
    S2 = S3;

end

% resize xmbit to remove last bit
xmtbit = xmtbit (1:n);

% initialize error count
errcnt = 0;

% compute total nr of errors
for i = 1:n
    errcnt = errcnt + xor(xmtbit(i),rcvbit(i));
end

Pb(p) = (errcnt/n);
SNR(p) = 10*log10(R*PWR(p)*(sqrt(T/(2*No))));

end

```

```

% procedure to save data to .mat file
clear P S;
load ideal2dat;
P=[P,Pb]
S=[S,SNR]
clear L A R No Zo SM t T Td i n Pb SNR errcnt S1 S2 S3 rcvbit xmtbit;
clear f PWR phase p xa xb;
save ideal2dat;
clear

```

```

% Naval Postgraduate School
% Created by: LT Paul W. Wehner

```

2. ONE CHANNEL TRANSMITTER

```

function [S,xmtbit] = onechxmt(f,phase)
% 1 CHANNEL DPSK TRANSMITTER one bit output
% [S,XMTBIT] = ONECHXMT(F)
% Creates a random transmit (XMTBIT) bit of one or zero.
% Based on transmit bit it returns a signal
% (S) one period in length that is inphase
% if XMTBIT is a zero and 180 degrees out of
% phase if xmtbit is one.

```

```

% decide which bit transmitter will simulate
% signal to send

```

```

T=1/f; % compute period of signal

```

```

t=linspace(0,T); % generate 100 time intervals

```

```

x= rand - 0.5;

```

```

if x <= 0
    xmtbit=0;
    S=phase*cos(2*pi*f.*t);
    % compute S for XMTBIT = 0

```

```

else
    xmtbit=1;
    S=-1*phase*cos(2*pi*f.*t);
    % compute S for XMTBIT = 1

```

end

% Naval Postgraduate School, ECE
% Created by: LT Paul W. Wehner

3. MACH-ZENDER COUPLER

```
function [a,b] = mzcoupsm(S,T,Td,SM1,SM2,SM3,L)
% MACH ZENDER COUPLER with varied scattering matrices output
% For a given input signal, S (with a period T,
% three periods in length), returns two signals,
% A and B (both one period in length) where
%  $A = S(t-T_{\text{actual}})+S(t)$  and  $B=S(t-T_{\text{actual}})-S(t)$ .
% T_ACTUAL indicates the actual length
% (i.e.,seconds) of the coupler delay
% element and SM# indicates the
% scattering matrix of the individual #'rd
% 2x2 optical couplers. L is the attenuation
% in channel a to equalizer signal strength
% lost in channel b due to the last phase
% shift.

% determine # discrete quantities in
% a signal period (T) of S
n = length (S)/3;

% demux signal S in 1st 2x2 coupler
[a1,b1] = optcoup2(SM1,S);

% delay signal in channel a
[a2,d] = delay(a1,T,Td);

% adjust length of channel a and
% channel b signals
a3 = a2(d-n+1:d);
b2 = b1(d-n+1:d);

% 2nd 2x2 coupler output
[a4,b3] = optcoup2(SM2,a3,b2);

% phase shft element output
```

```

[q,b4] = optcoup2(SM3,b3);

% attenuate channel a
[a5] = atten(a4,L);

% define MZ coupler output
a = real(a5);
b = real(b4);

% Naval Postgraduate School
% Created by: LT Paul W. Wehner

```

4. OPTICAL COUPLER

```

function [a,b] = optcoup2(SM,S1,S2)
% optical 2x2 coupler
% OPTCOUP2(SM,S1,S2)
% For a given input signal, S1, and a possible
% second signal S2, provides two outputs,
% A and B. Both outputs are attenuated by a
% factor of 3dB and multiplied by the scattering
% matrix, SM. SM must be [2x2].

% determine if second signal S2 was input
if nargin == 2
    S2=zeros(1,length(S1));
elseif length(S1) ~= length(S2)
    disp('ERROR - Input arrays (S1 and S2) must')
    disp(' be of the same length')
    a=0;
    b=0;
    return;
end

% define input matrix
y = [S1;S2];

% multiply by scattering matrix
x = SM*y;

% attenuate output by 3dB

```

```

x = x./sqrt(2);

% define individual outputs
a = x(1,:);
b = x(2,:);

% Naval Postgraduate School
% Created by: LT Paul W. Wehner

```

5. DELAY ELEMENT

```

function [a,d] = delay (a,T,Td)
% DELAY ELEMENT
% DELAY(A,T,Td), for a given signal A (A must
% be three periods in length with a period of
% T seconds) outputs a new signal A delayed Td
% seconds. Indicates at which element
% value, N, in a the delayed vector begins
% where the vector is listed right to left

% create working copy of a
b = a;

% determine # discrete quantities of one
% period of a
i = length(a)/3;

% compute delay as percentage of actual delay
perc_Td = Td/T;

% equate percent delay to # of discrete
% quantities of a
j = round(i * perc_Td); % quantized delay
k = (3*i) - j; % new start of a

% zero out delayed discrete elements of a
for l = (3*i):-1:(k+1)
    a(l)=0;
end

```

```

m = 3*i;

% overwrite a with delayed version of itself
for n= k:-1:(2*i-j+1)
    a(n)=b(m);
    m=m-1;
end

d=k;

% Naval Postgraduate School, ECE
% Created by: LT Paul W. Wehner

```

6. ATTENUATOR

```

function [a] = atten(a,L)
% ATTENUATOR
% ATTEN(A,L)
% For given input signal, A, performs
% attenuation on signal equal to
% L dB.

```

```

a = a / (sqrt(10^(L/10)));

```

```

% Naval Postgraduate School
% Created by: LT Paul W. Wehner

```

7. ELECTRICAL CIRCUIT ELEMENTS

```

function [rcvbit] = rcvr(xa,xb,R,Zo,No,T)
% OPTICAL DPSK SIGNAL RECEIVER OUTPUT
% [RCVBIT]=CRCVR(XA,XB,R,ZO,NO,T)
% For given input signals, XA and XB
% this applies photodetection
% proportional to the responsivity (R) to
% convert the optical signal to electrical,
% amplifies the electrical signal
% with a gain of (Zo) and then
% integrates the signal over a
% single time period (T) to obtain signal

```

```

% energy in each branch. A comparison of
% two branches is then made to
% determine the transmitted bit. Noise is
% added in the photodetector and
% the amplifier with a power spectral
% density of  $N_0/2$ .

```

```

% input optical signal to photodetector
xa1 = pd(xa,R,No,T);
xb1 = pd(xb,R,No,T);

```

```

% input signal to transimpedance amplifier
xa2 = tranamp(xa1,Zo,No,T);
xb2 = tranamp(xb1,Zo,No,T);

```

```

% integrate both channels over T
xa3 = intg(xa2,T);
xb3 = intg(xb2,T);

```

```

% compare channels to decide received bit
if xa3 > xb3
    rcvbit = 1;
else
    rcvbit = 0;
end

```

```

% Naval Postgraduate School
% Created by: LT Paul W. Wehner

```

8. PHOTODETECTOR

```

function [a] = pd(x,R,No,T)
% PHOTODETECTOR
% PD(x,R,No,T)
% For given input signal, X, performs
% photodetection on signal power proportional
% to the responsivity, R, in amps/watt.
% Assume signal is output over a 1 ohm
% load such that amps correlate directly to
% volts. Adds photodetection shot noise to
% output signal A with PSD( $N_0/2$ ) as defined
% from user input.

```

```

% Create shot noise
s = randn(1,length(x));

% adjust shot noise PSD
amp = sqrt(No/T);
s = amp * s;

% compute signal power
Px = (x.^2)./2;

% multiply input power by responsivity
% to get output in amps
Ax = R * Px;

% add shot noise to create output signal
a = Ax + s;

% Naval Postgraduate School
% Created by: LT Paul W. Wehner

```

9. TRANSIMPEDANCE AMPLIFIER

```

function [a] = tranamp(x,Zo,No,T)
% TRANSIMPEDANCE AMPLIFIER
% TRANAMP(x,Zo,No,T)
% For given input signal, X, performs
% uniform amplification on signal
% with gain Zo. Adds noise to signal prior
% to amplification with PSD No/2.
% Assume signal is output over a 1 ohm
% load such that amps correlate directly to
% volts. Adds photodetection shot noise to
% output signal A with PSD(No) as defined
% from user input.

% Create amp noise
s = randn(1,length(x));

% adjust amp noise
amp = sqrt(No/T);
s = amp * s;

```

```
% add amp noise to input signal
```

```
a = x + s;
```

```
% adjust output by gain, Zo
```

```
a = Zo * a;
```

```
% Naval Postgraduate School
```

```
% Created by: LT Paul W. Wehner
```

10. INTEGRATOR

```
function [a] = intg(x,T)
```

```
% INTEGRATOR
```

```
% INTG(x,T)
```

```
% For given input signal, X, performs
```

```
% trapazoidal integration on signal
```

```
% over one time period T. Assumes
```

```
% elements of X are equally spaced
```

```
% from 0 to T.
```

```
a = (T/length(x)) *trapz(x);
```

```
% Naval Postgraduate School
```

```
% Created by: LT Paul W. Wehner
```

11. Q FUNCTION

```
function [Q,P] = qfn(x)
```

```
% This function computes the Gaussian Q-function
```

```
% using the rational approximation 26.2.17 of
```

```
% Abromowitz and Stegun. For sufficiently large
```

```
% arguments, the asymptotic expansion 26.2.12 is used.
```

```
% The rational approximation is accurate to within
```

```
% 7.5e-8. Q is the value of the Q-function (integral of
```

```
% Gaussian pdf) of zero mean and unit variance from the
```

```
% input quantity to infinity, and P = 1 - Q is the
```

```
% cumulative distribution function. The call is
```

```

% [Q,P] = qfn(x).
%
% R.E. Ziemer
% 4/17/94

b(1)=0.31938153;
b(2)=-0.356563782;
b(3)=1.781477937;
b(4)=-1.821255978;
b(5)=1.330274429;
p=0.2316419;
y=abs(x);
T=1/(1+p*y);
TT=zeros(1,5);
for r=1:5
    TT(r)=T^r;
end
Z=exp(-y^2/2)/sqrt(2*pi);
if y<4
    Q1=Z*b*TT';
else
    Q1=(Z/y)*(1-1/y^2+3/y^4);
end
if x>0
    Q=Q1;
else
    Q=1-Q1;
end
P=1-Q;

```

LIST OF REFERENCES

1. Wilner, Alan Eli, "Mining the optical bandwidth for a terabit per second," *Spectrum*, April 1997, pp32-41.
2. Heinbaugh, Maryanne, "The Mach-Zender Coupler," Master's Thesis, Naval Postgraduate School, Monterey CA, 1997.
3. Ha, Tri, *Private Communications*, Naval Postgraduate School, Monterey CA, 1996-1997.
4. Powers, John, *An Introduction To Fiber Optic Systems (second edition)*, Richard D. Irwin, Inc., Chicago IL, 1997.

INITIAL DISTRIBUTION LIST

1. Defense Technical Information Center.....2
8725 John J. Kingman Rd., STE 0944
Ft. Belvoir, Virginia 22060-6218
2. Dudley Knox Library.....2
Naval Postgraduate School
411 Dyer Rd.
Monterey, California 93943-5101
3. Department Chairmen, Code EC.....1
Department of Electrical and Computer Engineering
Naval Postgraduate School
Monterey, California 93943-5101
4. Professor Tri Ha, Code EC/Ha2
Department of Electrical and Computer Engineering
Naval Postgraduate School
Monterey, California 93943-5101
5. Professor John P. Powers, Code EC/Po1
Department of Electrical and Computer Engineering
Naval Postgraduate School
Monterey, California 93943-5101
6. Commanding Officer.....1
(Attn: Code 30, CDR Zellmann)
Naval Information Warfare Activity
9800 Savage Rd.
Ft. Meade, MD 20755-6000
7. CDR Gus Lott, Code EC/Lt.....1
Department of Electrical and Computer Engineering
Naval Postgraduate School
Monterey, California 93943-5101
8. LT Paul W. Wehner.....1
310 Overbrook Rd.
Baltimore, MD 21212