



National  
Defence

Défense  
nationale



# GPS HEADING DETERMINATION USING SHORT ANTENNA BASELINES

by

M. Vinnins and L.D. Gallop

19980421 064

DTIC QUALITY INSPECTED 2

**DEFENCE RESEARCH ESTABLISHMENT OTTAWA**  
TECHNICAL NOTE 98-001

Canada

April 1997  
Ottawa

**DISTRIBUTION STATEMENT A**

Approved for public release;  
Distribution Unlimited



National  
Defence

Défense  
nationale

# **GPS HEADING DETERMINATION USING SHORT ANTENNA BASELINES**

by

**M. Vinnins and L.D. Gallop**  
*Navigation Group*  
*Aerospace Radar and Navigation Section*

**DEFENCE RESEARCH ESTABLISHMENT OTTAWA**  
TECHNICAL NOTE 98-001

Project  
3DG13

April 1997  
Ottawa

## ABSTRACT

Defence Research Establishment Ottawa has completed an exploratory investigation into the use of GPS as a method of heading determination for an in-ice Arctic surveillance sensor, known as an ice-pick sonobuoy, dropped from a surveillance aircraft into the ice cover of the Canadian high Arctic.

The parameters within which the system was to function included operation above a latitude of 80 degrees north with a bearing accuracy of better than 5 degrees. Due to the small diameter of the sonobuoy, the investigation was to center on the use of extremely short antenna baseline separations; 10 cm, if achievable, as well as the use of inexpensive, off-the-shelf receivers of small size and low power consumption.

The Department of Geomatics Engineering at the University of Calgary has developed a software package called 'HEAD' which was designed to accept phase data inputs from a pair of GPS receivers, each with their own antenna and provide heading and pitch information to the user in a non real-time environment. DREO licenced this system from U of C for the sonobuoy investigation.

Two receiver sets were evaluated; the Canadian Marconi CMT 8700 and the Motorola VP Oncore. Trials were performed at CFS Alert in the Canadian Arctic under various ice/snow and satellite geometry conditions and several baseline separations.

Test results indicated that GPS was a viable option for use in the ice-pick sonobuoy application providing heading accuracies of better than 5 degrees under almost all test conditions. This technology is also expected to be applicable to numerous other applications including land vehicle heading determination, artillery surveying, antenna pointing and targeting applications.

The system is now undergoing conversion to real-time operation for further evaluation in 1997.

## RÉSUMÉ

Le Centre de recherches pour la défense, Ottawa a terminé des travaux préliminaires sur l'utilisation du GPS dans l'analyse d'indication de cap pour un capteur de surveillance reposant sur la banquise de l'Arctique, appelé bouée acoustique à poinçon à glace, largué depuis un aéronef de surveillance sur la banquise de l'extrême Arctique canadien.

Les paramètres dans lesquels le système devait fonctionner tenaient compte d'opérations se déroulant à partir du quatre-vingtième degré de latitude Nord et ayant une précision de gisement supérieure à cinq degrés. La bouée acoustique ayant un petit diamètre, les travaux devaient principalement porter sur la possibilité de l'utilisation de séparations extrêmement petites de la base géodésique à antenne (10 cm) et sur l'utilisation de récepteurs d'emploi courant de petite taille, à faible consommation d'énergie et peu coûteux.

Le département de génie géomatique de l'Université de Calgary a mis au point un progiciel, appelé «HEAD», conçu pour recevoir des entrées de données de phase provenant d'une paire de récepteurs de GPS, qui possèdent chacun leur propre antenne et fournissent des renseignements sur l'indication de cap et le registre à l'utilisateur dans un environnement en temps non réel. Le CRDO a permis que ce système de l'Université de Calgary soit utilisé pendant les travaux sur la bouée acoustique.

L'évaluation a porté sur deux postes récepteurs : le CMC 8700 de Canadian Marconi et le VP Oncore de Motorola. Les essais ont eu lieu à la SFCAAlert dans l'Arctique canadien sous diverses conditions de glace et de neige, avec diverses positions des satellites et plusieurs séparations de la base géodésique.

Les résultats des tests ont démontré que le GPS constituait une solution viable quant à son utilisation dans l'application de la bouée acoustique à poinçon à glace puisque la précision des indications de cap qu'il fournit est supérieure à cinq degrés dans presque toutes les conditions d'essai. On s'attend à ce que cette technologie soit aussi applicable à de nombreuses autres applications telles que l'analyse d'indication de cap pour véhicule terrestre, l'arpentage d'artillerie, le pointage d'antenne et le choix des objectifs.

Le système est en train de subir une conversion pour opérer en temps réel et passera d'autres évaluations au cours de 1997.

## EXECUTIVE SUMMARY

Defence Research Establishment Ottawa has completed an investigation into the use of Global Positioning System (GPS) Attitude Determination System (ADS) technology as a method of heading determination for an in-ice Arctic surveillance sensor, known as an ice-pick sonobuoy, dropped from a surveillance aircraft into the ice cover of the Canadian high Arctic.

The parameters within which the system is to function include operation above a latitude of 80 degrees north with a bearing accuracy of better than 5 degrees. Due to the small ( approximately 10 cm ) diameter of a sonobuoy, the investigation centred on the use of an extremely short GPS antenna separation. A 10 cm separation as well as the use of inexpensive, off-the-shelf components of small size and low power consumption were of prime importance during the investigation.

The Department of Geomatics Engineering at the University of Calgary has developed a software package called HEAD which was designed to accept carrier phase measurements from two separate GPS receivers, each with their own antenna, and provide heading and pitch information to the user in a non real-time environment. DREO licenced this system from U of C for this investigation.

Two receiver sets were evaluated; the 12-channel Canadian Marconi CMT 8700 and the 8-channel Motorola VP Oncore. Two separate data recording systems were assembled along with reference systems. Trials were performed at CFS Alert in the Canadian Arctic under various snow, ice and satellite geometry conditions and over a range of antenna baseline separations ranging from 10 to 90 cm.

Performance criteria include accuracy and stability performance as well as Time-To-Resolution (TTR) and availability. Test results show that GPS is a viable option for use in the ice-pick sonobuoy application providing heading accuracies of better than 5 degrees under most conditions, a Time-To-Resolution of 3 to 5 seconds and an availability of 90 percent for roll and pitch angles of less than 30 degrees for an antenna separation of 10 cm.

This technology is also applicable to several other military applications including vehicle heading determination, artillery survey, antenna pointing and targeting applications..

The system is now undergoing conversion to real-time operation for further evaluation in 1997.

**TABLE OF CONTENTS**

**1.0 INTRODUCTION . . . . . 1**  
1.1 Background and Objectives . . . . . 1  
1.2 Project Description . . . . . 4  
1.3 Software . . . . . 8  
1.4 Hardware . . . . . 8  
    1.4.1 Canadian Marconi CMT 8700 ALLSTAR . . . . . 8  
    1.4.2 Motorola VP Oncore . . . . . 9  
    1.4.3 Trimble TANS Vector . . . . . 9

**2.0 TEST PARAMETERS . . . . . 14**  
2.1 Definition of Terms . . . . . 14  
2.2 Field Test Plan . . . . . 15  
    2.2.1 Antenna Separation . . . . . 19  
    2.2.2 Pitch Angle . . . . . 19  
    2.2.3 Roll Angle . . . . . 19  
    2.2.4 Drift/Stability Tests . . . . . 19  
    2.2.5 Ice/Snow Masking . . . . . 19

**3.0 TEST RESULTS . . . . . 24**  
3.1 CMT 8700 Results . . . . . 24  
3.2 Motorola VP Oncore Results . . . . . 33  
3.3 Summary of Results . . . . . 40  
3.4 Discussion . . . . . 44

**4.0 CONCLUSIONS AND RECOMMENDATIONS . . . . . 49**  
4.1 Conclusions . . . . . 49  
4.2 Recommendations . . . . . 50

**5.0 REFERENCES . . . . . 52**

## 1.0 INTRODUCTION

### 1.1 Background and Objectives

In early 1995, DREO was approached by Director Maritime Aircraft Engineering and Maintenance ( DMAEM ) to carry out an exploratory investigation in support of CF requirements for an in-ice Arctic surveillance sensor capable of resolving the direction of an under-ice sound source. This was initiated as an 'informal' task to investigate the feasibility of employing the Global Positioning System (GPS) for this application.

The problem was defined as: 'determining the bearing of an incoming sound source originating under Arctic ice cover to an 'ice-pick' sonobuoy dropped from a surveillance aircraft employing Global Positioning System (GPS) Attitude Determination System (ADS) technology.' The parameters within which the system was to function included operation above a latitude of 80 degrees north with a bearing accuracy of < 5 degrees. For obvious reasons, low cost, small size and low power consumption were important for this type of application.

It should be emphasized at this point that no attempt was made, as part of this study, to address the 'engineering' problem of integrating GPS with the existing ice-pick sonobuoy as currently used by the Canadian Forces. This investigation was limited to an investigation of GPS technology for such an application. Nonetheless, the design and operational deployment of the sonobuoy was used as the 'envelope' for developing the GPS heading determination system that was tested as part of this investigation. In particular, such requirements as small size and very low power consumption were considered in procuring receivers to be tested but one of the most important considerations was the use of existing technology; no attempt was made to redesign or modify off-the-shelf receivers. The primary reason for this is the requirement for extremely low cost; this item will be, in an operational environment, disposable! Similarly, no attempt was made to modify or adapt the manufacturer-provided antennas at this time; the antennas are commercially available designs. Irrespective of these limitations, the test program was designed to push the limits of how these commercial receivers had been previously employed; the most significant consideration being the desire to minimize the baseline distance between the two antennas and develop heading determination software to accomplish this. In a practical sense, implementation of this technology with the ice-pick sonobuoy will require antenna separations approaching 10 cm. This was the primary focus of this study. Nonetheless, extension of this

technology to other applications of a similar nature was also a priority. Applications include fire control systems, artillery survey, vehicle navigation/attitude determination and a host of others.

The use of GPS as a method of attitude determination is well documented [1], [2], [3], but the basic principles will be repeated here to enable an understanding of some of the advantages and limitations in this application.

The fundamental principle of attitude determination using GPS signals is based upon the use of interferometry techniques employing two or more GPS antennas. Due to the very large distance between any given GPS satellite and a GPS receiver on or near the surface of the earth, the arriving signal wavefront can be considered to be effectively planar. The GPS signal, travelling at the speed of light, arrives at the antenna closest to the satellite slightly before reaching the other antenna(s). By measuring the carrier phase difference between pairs of antennas, the GPS receiver can determine the relative distance between those antennas. By use of additional carrier phase measurements from multiple satellites and using three or more antennas, the receiver can determine the full three-axis attitude of the structure upon which the antennas are mounted [4].

Numerous GPS receivers have been designed and developed for attitude determination purposes. Manufacturers of some commercially available systems include Ashtech [5], Trimble [6] and Adroit Systems [7] among others. In addition, a number of researchers have developed algorithms to perform attitude determination functions while employing very inexpensive, off-the-shelf OEM-type receivers.

The use of GPS for attitude determination has several distinct advantages, one of the primary ones being that signals from only 2 GPS satellites are required to determine attitude information between two antennas. Unlike position determination from GPS which requires signals from 4 satellites (to solve for the three dimensional position unknowns as well as receiver clock bias), attitude determination takes advantage of the fact that a common time reference is used within a receiver for all phase measurements cancelling out clock errors and the fact that in attitude applications, the antennas must be placed on a fixed, predetermined and, therefore, known baseline. These two criteria remove the necessity for 2 of the 4 satellite signals required for position determination. This implies several benefits to the user. The primary advantage is the high integrity of the solution due to the availability of at least 4 ( usually many more ) satellites at any point in

time providing inherent redundancy. Another benefit arises when the vehicle upon which the antennas are mounted is rolled or pitched to extreme angles since the attitude solution will continue to be available as long as at least two satellites remain in view. Additional benefits include easier detection of cycle slips and fast resolution of integer ambiguity due to availability of redundant measurements from other satellites.

The use of GPS for attitude determination is not without some potential limitations, however. As stated above, baseline length is assumed to be a predetermined constant in an attitude determination application. Two limitations exist because of this requirement; firstly the requirement for a rigid, non-varying structure for the baseline between antennas and, secondly, the fact that accuracy of the attitude solution decreases with reduced baseline length. The necessity for a fixed baseline length is intuitively obvious since variation of the baseline translates to apparent phase shift and, thus, a change in apparent attitude. The second limitation is not quite as obvious but results from the increasing effect of phase noise and multipath on angular accuracy as antenna separation distance decreases [8]. It should be noted that significant work has been done in this area and that most commercial attitude determination systems such as those referenced above employ baseline lengths of at least one meter or more for optimal performance. The ice-pick sonobuoy, by its very nature, precludes the use of such long baselines for all practical purposes. This limitation thus becomes the primary focus of the investigations described in this report although the results can be applied to any application wherein the antenna separation must, of practical necessity, be small.

With the potential advantages and limitations described above, DREO approached several manufacturers of GPS equipment as well as other researchers working in this field. The University of Calgary, Department of Geomatics Engineering, under Drs. Lachapelle and Cannon have performed extensive development work in short baseline attitude determination systems using GPS for a variety of potential applications including land vehicle navigation, artillery survey and fire control systems [9,10,11]. Discussions with Dr. Lachapelle indicated that U of C was developing a software package which was capable of accepting raw phase data measurements from individual pairs of GPS receivers from a variety of manufacturers and processing the data to obtain attitude information. This software, although developmental, was available, under licence, for our use. In addition, the requirement for low cost receivers for the sonobuoy application (ideally less than \$100.00 in

production quantities) led us to the conclusion that simple OEM-type equipment would be best suited to this application since the receivers would have to be built directly into the body of a sonobuoy in order to be practical. Numerous manufacturers sell OEM equipment and several were approached and requested to produce receivers capable of providing raw phase measurements as required by the attitude determination software.

Based upon these investigations, DREO submitted a proposal to the Sonobuoy Coordinating Committee in November of 1995 to carry out a tasking to investigate the feasibility of using GPS to provide heading for the ice-pick sonobuoy.

## 1.2 Project Description

A formal proposal was presented to the Sonobuoy Coordinating Committee which contained four major tasks;

a. investigate the present status and projected future developments of short baseline GPS attitude determination systems through contact with other researchers and manufacturers to determine performance capabilities, size, cost, power consumption, antenna types and availability of candidate receivers and appropriate processing software.

b. procure at least one receiver pair and either develop or procure support software to enable field trial evaluation in an Arctic environment.

c. perform field trials in the Canadian high Arctic to investigate all aspects of performance including;

- initialization / time-to-first-fix (TTFF)
- effects of multipath
- snow / ice effects
- high latitude ( > 80 deg ) performance
- baseline length
- antenna masking effects ( due to angle of impact of the sonobuoy)
- receiver technology differences ( number of receiver channels, etc.)
- effects of satellite geometry and availability
- other potential performance related effects

d. submit a report on the results of the investigation including performance limitations and proposing options for future consideration.

The proposal was accepted and DREO was provided with \$50K of project funding to perform the work.

A contract was let with the University of Calgary to provide and licence a prototype software package called HEAD which was designed to accept phase data measurements from a pair of GPS receivers and provide non-real-time, postprocessed heading and pitch between a single pair of antennas. At that point, U of C had evaluated three manufacturers' receivers, one from Canadian Marconi Company another from Motorola and a third from Novatel. The Novatel receivers employ several highly advanced GPS technologies and, although very attractive from a performance viewpoint, are also very costly. It was decided to pursue the far less expensive Marconi and Motorola alternatives. It should be noted that there are many GPS receivers and manufacturers in the market but most receivers do not normally provide raw phase data measurements as part of their standard output; both the Marconi and Motorola do. (Any receiver can be modified by the manufacturer to provide this data if desired) DREO procured two of each of these receivers for this project and provided them, along with a computer, to U of C for integration. The prototype test system was delivered to DREO in the spring of 1996.

DREO performed a series of preliminary on-site field trials during the summer of 1996 and developed extensive data logging enhancements and improvements to the operator interfaces to simplify and speed up the test and evaluation process. The equipment was installed into the DREO Mobile Navigation Laboratory, an 8x12x8 foot shelter which can be truck-mounted for field trials of navigation equipment. A photograph of the shelter is shown in Figure 1. In addition, mechanical mockups of a 'sonobuoy' were designed and built to permit simulation of a realistic sonobuoy installation. A photograph of the mockups is shown in Figure 2. The mobile laboratory was also outfitted with several reference systems including a commercial Trimble TANS Vector attitude determination system owned by DREO. This system provides very precise full 3-axis attitude information but requires a minimum antenna baseline separation of 1.5 meters [12]. A mechanical gyrocompass was also installed and data logging software was developed for both systems for comparison with the sonobuoy prototypes. These on-site field tests provided a method for developing a field trial plan for use in the Arctic trials.

With the assistance of the Director DISO Support (DDS) a field trial was scheduled to take place at CFS Alert in October/November 1996.

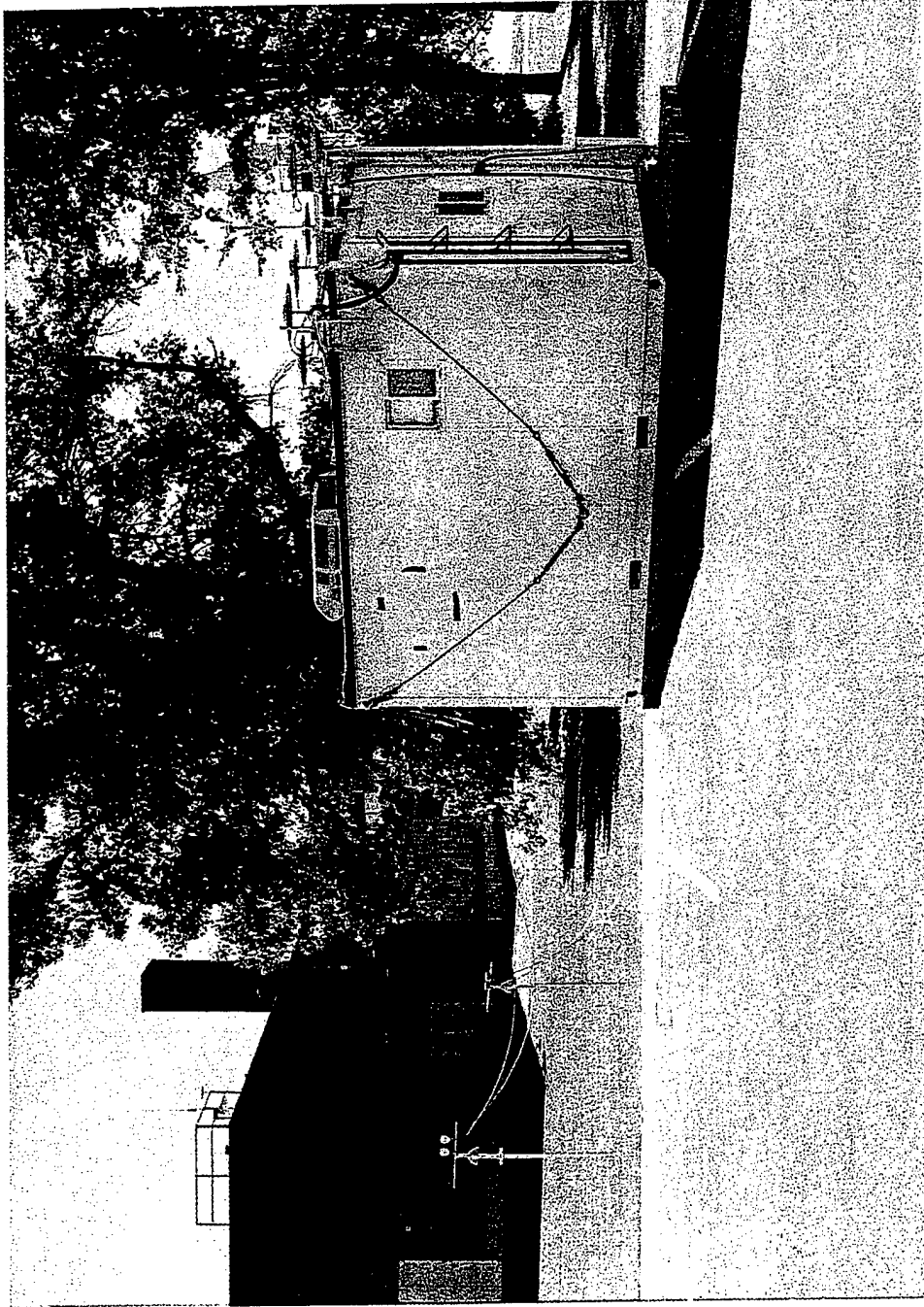

Figure 1. Mobile Navigation Laboratory Shelter

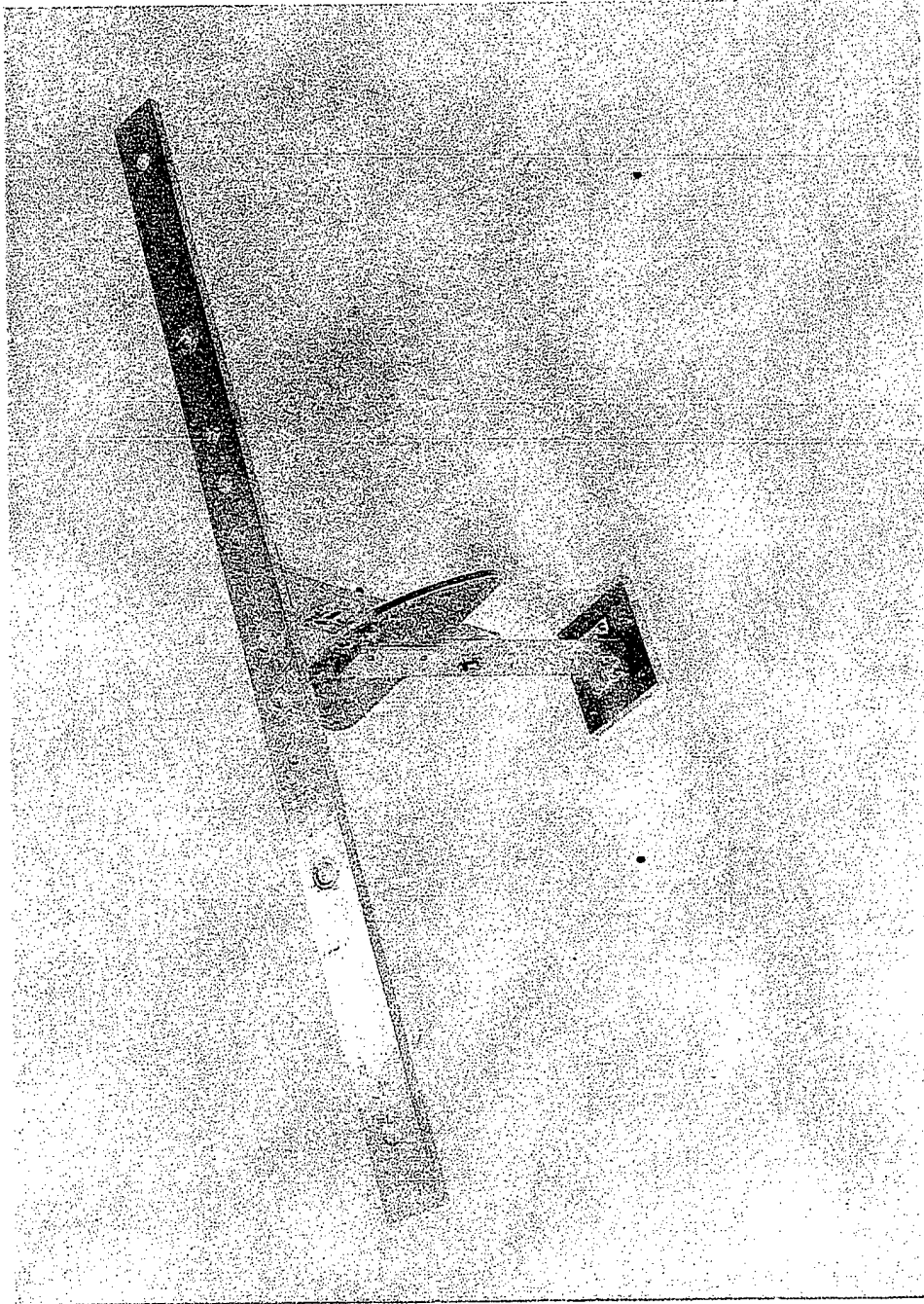

Figure 2. Sonobuoy Antenna Fixture

### 1.3 Software

Three separate software procedures are required to implement the prototype system; data acquisition and logging, attitude determination processing and plotting/analysis software.

Data acquisition and logging is an operator-initiated procedure which captures selected data from the two GPS receivers at a 1 Hz rate and records it into an individual raw data file for each receiver in a format compatible with the HEAD processing software. Data logging is manually initiated and stopped by the operator and requires that the two GPS receivers be initialized and receiving satellite data from sufficient satellites to function in a normal manner. This receiver initialization is typically automatic for a given receiver and is a function of the manufacturers' implementation of satellite search and acquisition algorithms. This aspect of attitude determination system performance in an operational system will be discussed in more detail at the end of this report since it may have several significant implications. Data acquired from each receiver includes not only the raw phase data but also GPS position data and time.

The HEAD attitude determination software is, in its present implementation, a post-processing algorithm which uses a double difference carrier phase approach and integer ambiguity resolution on-the-fly to determine the 3-dimensional vector between the two antennas to within a few cm.[13] This 3D vector is transformed into attitude components using an algorithm as described in [14] and [15]. HEAD requires the receivers to track signals from 5 satellites in order to resolve phase ambiguities ( the number of integer wavelengths between the two antennas). The output of HEAD is a series of data files containing heading and pitch information, receiver position and time information as well as performance analysis information on residuals, ambiguity searches, etc. which are of use to the operator during this system development phase. In all, HEAD outputs five separate data files as described in the HEAD user manual [16].

Data analysis software consists of plotting routines and performance-related calculations which provide statistical analysis of the overall performance of the system under various test conditions. This data is presented in Chapter 3.

## 1.4 Hardware

### 1.4.1 Canadian Marconi CMT 8700 ALLSTAR

The CMT 8700 GPS receiver is a 12 channel "all-in-view" GPS receiver operating on the L1 C/A code employing both code and carrier phase tracking. The all-in-view feature is an attractive technology since the receiver is capable of tracking up to 12 satellites simultaneously ( the maximum number of satellites theoretically in view at any point in time). This provides for maximum measurement redundancy. Data communication with the receiver is via RS-232 or 422 interface in standard NMEA format. This receiver was procured in a ruggedized enclosure with manufacturer-provided development software. Neither the enclosure nor the software would be required in an operational system. Power consumption is less than 1.5 watts and the receiver is all contained on a single electronic card. The CMC 8700 receiver is shown in Figure 3.

### 1.4.2 Motorola VP Oncore

The VP Oncore receiver is an 8 channel GPS receiver also employing L1 C/A code. Data communication is via serial interface in NMEA format. Again, this receiver was procured in a ruggedized enclosure with manufacturer-provided development software. Power consumption is 1.1 watts and the receiver is contained on a single board. Figure 4 shows the VP Oncore receiver and antenna.

### 1.4.3 Trimble TANS Vector

The Vector is a 6 channel, commercial 3D attitude determination system employing 4 antennas with a minimum baseline separation of 1 meter although the manufacturer recommends 1.5 to 2 meter separation for optimum performance. This system has been used extensively by DREO in numerous applications including both land vehicle and ship navigation and attitude determination. Performance is typically 0.3 degrees in roll, pitch and heading and serves well as a reference system for field trials since extensive software has been developed by DREO and the system performance has been verified against high performance inertial systems. The Vector was mounted directly on the roof of the mobile laboratory in a permanent fashion for these field trials. Attitude data is collected from Vector at a 10 Hz rate.

### 1.4.4 Arma-Brown Gyrocompass

The Arma-Brown gyrocompass is a spinning-wheel, gimballed, north-seeking gyroscope. This technology,

although quite old, is very reliable as a true heading reference and is independent of GPS. Gyrocompass performance is usually limited to lower latitudes ( $< 65$  deg) and was originally intended for use mainly during local (Ottawa-area) trials. The gyrocompass was fitted to the floor of the mobile laboratory and heading output was recorded from a synchro-to-digital recorder.

A block diagram of the hardware employed for the trials is shown in Figure 5.

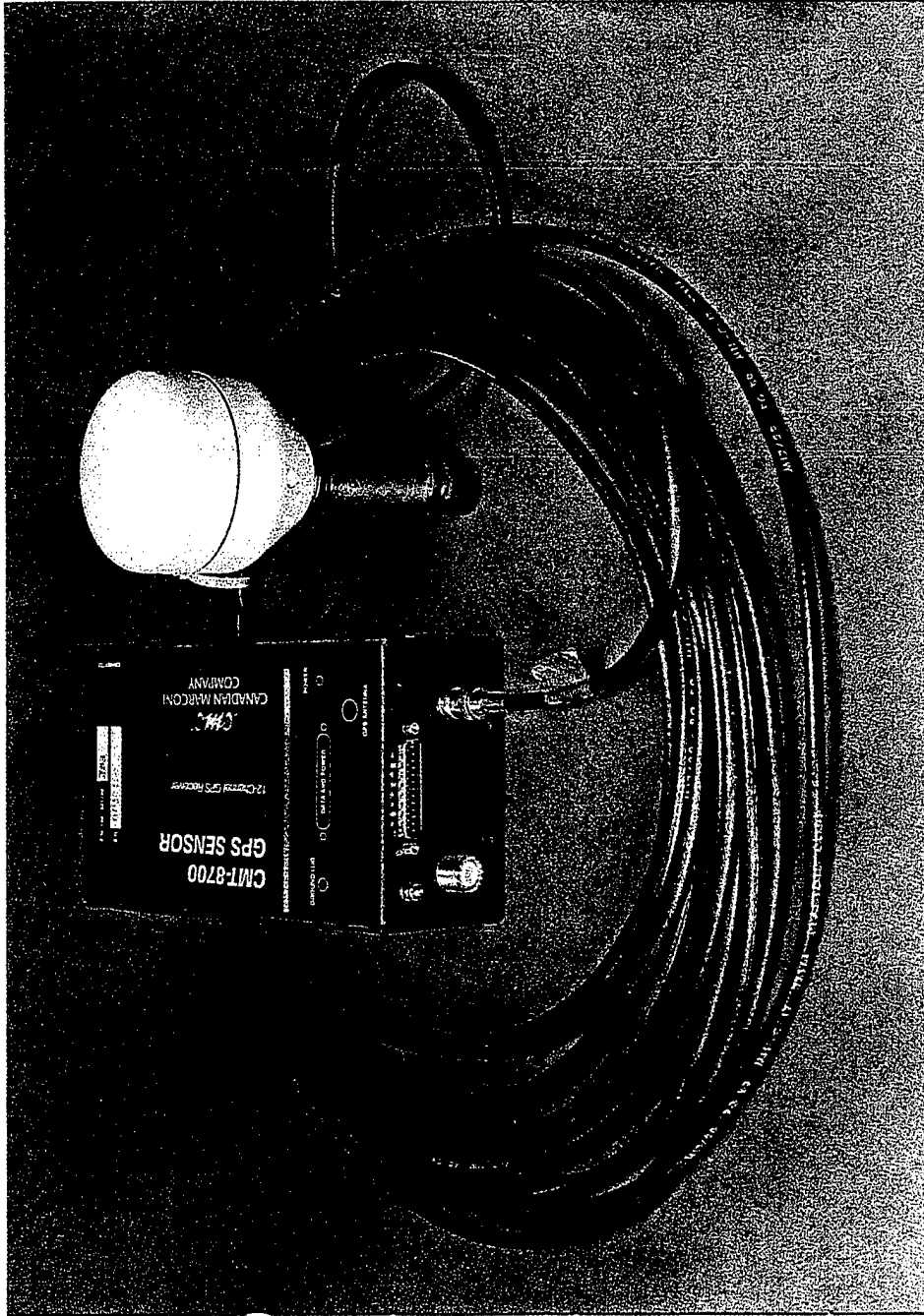

Figure 3. Canadian Marconi Company CMT 8700 GPS Receiver and Antenna

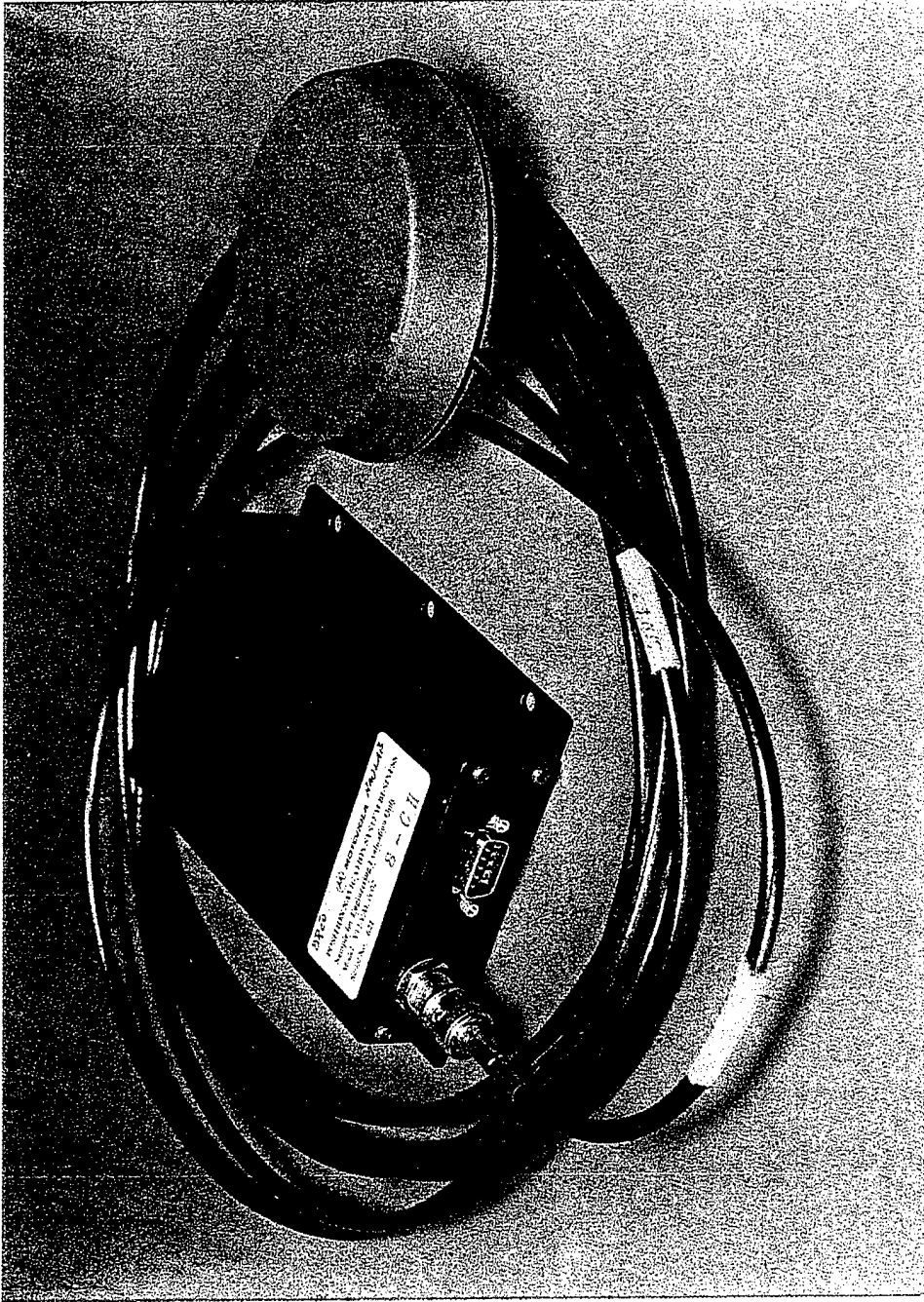

Figure 4. Motorola VP Oncore GPS Receiver and Antenna

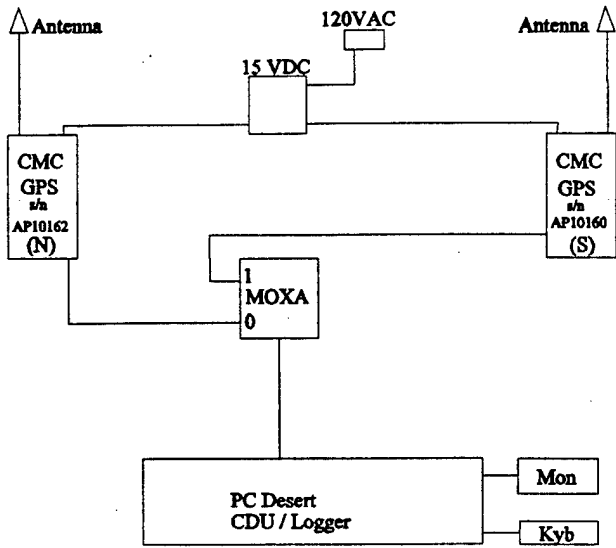

Figure 5a CMC 8700 Hardware Configuration

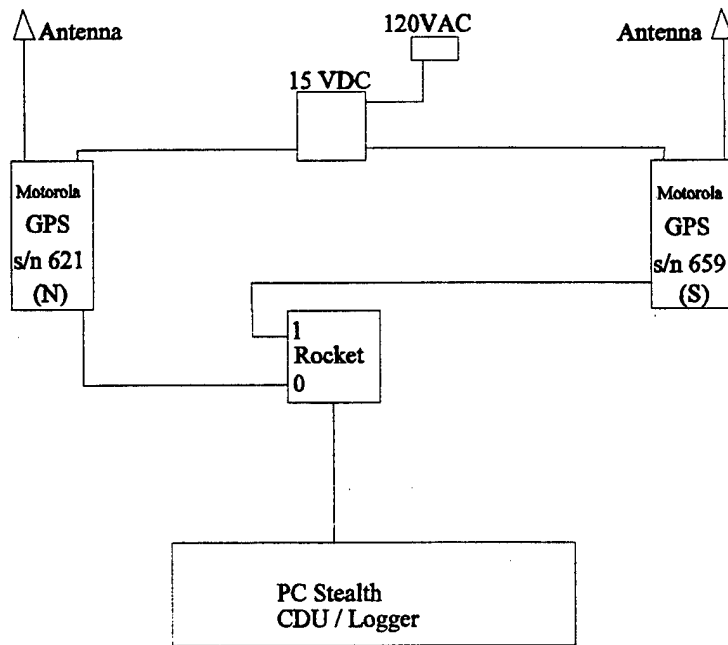

Figure 5b Motorola VP Oncore Hardware Configuration

## 2.0 TEST PARAMETERS

### 2.1 Definition of Terms

As in any new technology, users familiar with the technology tend to develop terms which are specific to that field of work. Numerous terms and definitions are standard to the GPS system and will not be redefined here. For a comprehensive discussion of GPS, numerous publications exist and are readily available but several terms are of particular significance to this investigation as related to the ice-pick sonobuoy. Before we begin using any of these terms, it would be useful to define them for the reader. The following terms are used in this report and are defined as follows:

**Time-To-First-Fix (TTFF)** - this is a universally accepted term for all GPS receivers and refers to the elapsed time from 'turn-on' of the receiver until the output of the first position solution. There are several conditions under which TTFF is determined and they include whether or not the receiver has a valid almanac (stored in non-volatile memory) or whether it must perform a 'search-the-sky' sequence in order to acquire an almanac. Each receiver manufacturer provides a specification for their receiver for each of these conditions. This term becomes significant for the ice-pick sonobuoy in an operational environment, as will be discussed later. During the trials performed as part of this investigation, TTFF was not measured directly.

**Time-To-Resolution** - this is defined as the elapsed time from which the first raw phase measurement is provided to the HEAD processor until the first attitude output is provided from HEAD.

**% Availability** - the percentage of time that heading and pitch output is provided by HEAD beginning at the time of the first output and ending upon the termination of phase data being provided to HEAD. Note that this assumes proper receiver initialization and does not include the time-to-resolution.

**Dropouts** - the times during which no output is available from HEAD (after time-to-resolution) even though phase data is being provided by the receivers.

**PDOP - Position Dilution of Precision** - a unitless, figure of merit term related to satellite geometry which, when multiplied by satellite ranging errors, results in an estimated user position (3D) error.

Multistable Output - the output of **incorrect** heading and/or pitch from HEAD. Note that the user may not be aware of this without access to some external attitude reference.

Cycle Slip Tolerance - a user-controlled parameter of HEAD. This parameter and its effects on the performance of HEAD are being characterized as part of this investigation. This term is described in the HEAD user manual.

Carrier Phase Variance - same comment as cycle slip tolerance, above.

## 2.2 Field Test Plan

The field test plan was designed to exercise the two heading determination receiver pairs, the CMT 8700 and the Motorola VP Oncore, in as realistic a fashion as possible under Arctic conditions. The parameters which were considered important include; time of day, satellite geometry (PDOP), antenna baseline length, antenna baseline orientation (N/S,E/W,roll,pitch), ice/snow cover, receiver startup, and, to a minor extent, multipath effects.

In general, time of day and satellite geometry are related in that the satellite geometry repeats approximately every 24 hours and 4 minutes at any geographic location. The effects of varying satellite geometry were not expected to have a large influence on system performance, particularly in the high Arctic since, at high latitudes such as Alert (82 degrees north latitude), the number of visible satellites is actually larger than at some southern latitudes since one can effectively 'see' over the pole to satellites in another orbital plane. This is illustrated in Figures 6 and 7 [17]. The minimum of 5 satellites required by HEAD is satisfied at all times in the Arctic. Note from Figure 7b that, although no satellites pass directly overhead at high latitudes, the PDOP (Fig 6b) remains very stable (satellite geometry is good).

The effects of tipping and tilting the antenna baseline are intended to simulate the effect of 'dropping' an ice-pick sonobuoy from an aircraft and having it imbed itself, at some arbitrary angle, into the ice/snow. The effects of ice and snow cover are also attempts to simulate realistic operating conditions.

Receiver initialization, as previously mentioned, is a potential operational concern since the effective Time-to-First-Resolution is actually a combination of the receiver TTF and the above-defined Time-to-Resolution; no attitude output can be obtained unless the receiver is fully

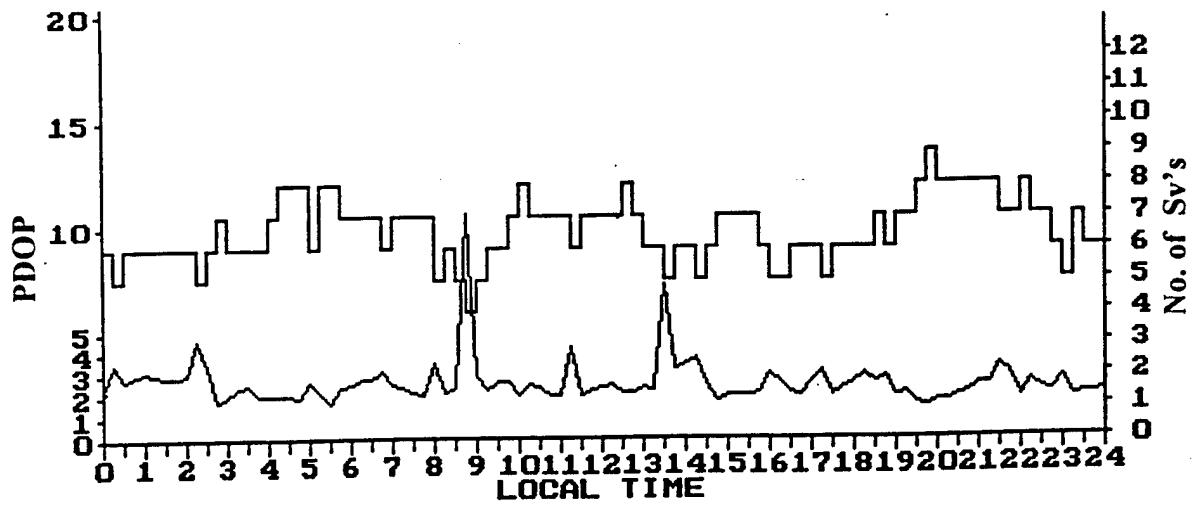

Figure 6a: 24 Hour PDOP at DREO (45°N Latitude)

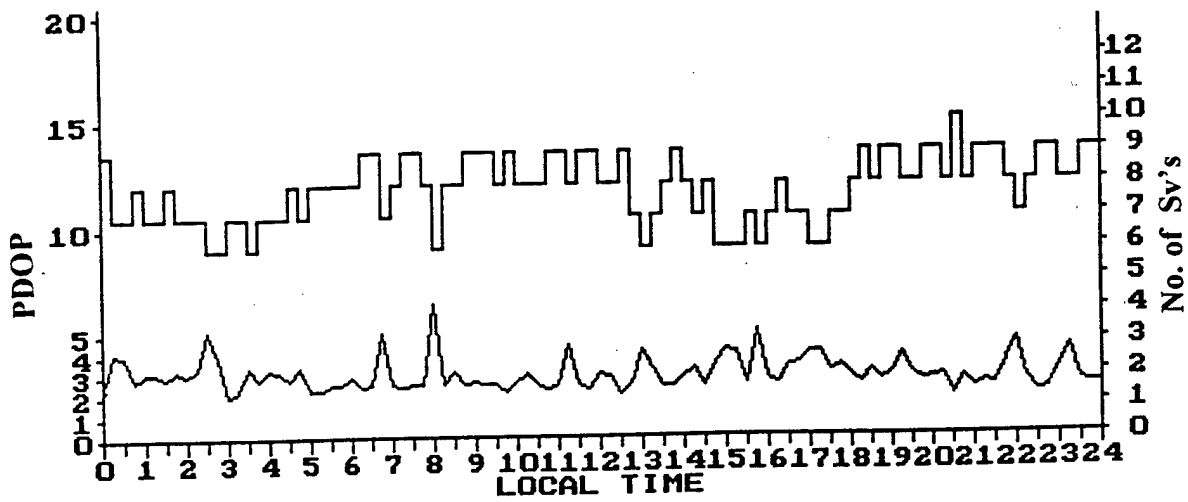

Figure 6b: 24 Hour PDOP at CFS Alert (82.5°N Latitude)

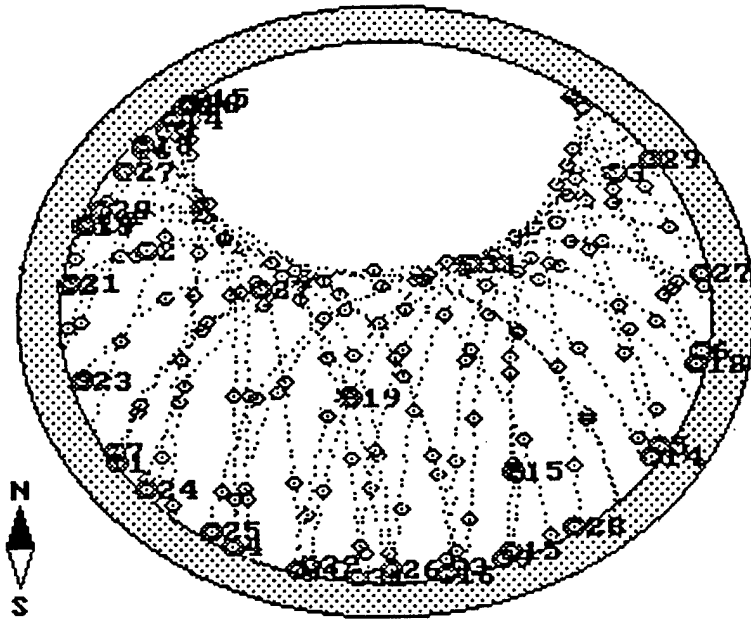

Figure 7a: Sky Plot of Satellite Availability at DREO (45°N Latitude)

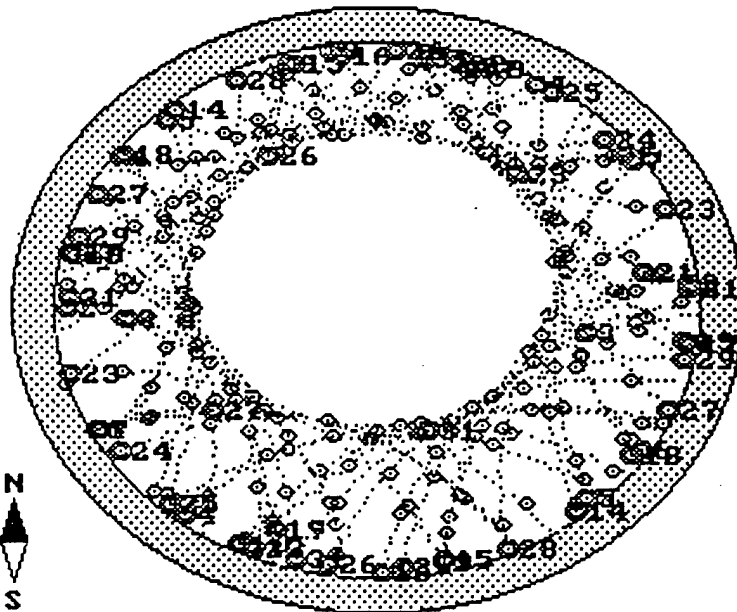

Figure 7b: Sky Plot of Satellite Availability at CFS Alert (82.5°N Latitude)

functioning and phase data is being processed by HEAD. TTFP is dependent upon the speed with which the receivers can acquire valid satellite almanac data ( if it is not already stored in non-volatile memory), determine their position and start sending data to the heading determination algorithms.

The effects of multipath, the reflection of GPS signals from external surfaces causing difficulties in accurately resolving satellite pseudo-ranges, has not been thoroughly investigated under arctic conditions and, although difficult if not impossible to predict and control, was expected to manifest itself in the attitude data as apparent 'drift' in the heading and pitch and will be discussed further in the data analysis section of this report. In this case, the use of extremely short baselines is expected to be an advantage in that two antennas placed very close together could be expected to see very similar (identical?) multipath.

Lastly, the variation in baseline length between antennas will indicate the accuracy limits to which the attitude can be determined. In general, a longer baseline improves accuracy and reduces the effective noise level but early results from tests at DREO and the University of Calgary have been very encouraging.

The following parameters were controlled, monitored or recorded during the trials:

- time of day
- PDOP ( satellite geometry )
- length of recording ( most tests were of 15 minute duration )
- reference data ( TANS Vector and gyrocompass )
- data rate ( 1 Hz )
- start up sequence ( receiver initialization )

The following data was recorded during each test:

- GPS time
- raw receiver data including position and phase data
- satellite geometry ( PDOP was recorded continuously from Vector )
- satellite masking angle ( also controllable during processing )

The following sections detail the individual tests that were performed during the field trial. Note that antenna separation is a variable for virtually all tests.

### 2.2.1 Antenna Separation

The hardware mockups shown in Figure 2 permit fixed baseline variations of 10, 20, 30, 50 and 90 cm. The antenna baseline can also be rolled or pitched through angles of 10, 20, 30, 40, 50 and 60 degrees. All combinations were employed during the trials.

The first test sequence consisted of orienting the antenna pairs for each of the CMC and Motorola receivers along a north/south axis and varying the baseline length from 10 to 90 cm. This was repeated 3 times. The antennas were then oriented along an east/west axis and the tests again repeated.

### 2.2.2 Pitch Angle

The antennas were pitched to angles of 0 to 60 degrees and the baseline varied through 10, 20 and 50 cm. This was repeated several times.

### 2.2.3 Roll Angle

The antennas were rolled through angles of 0 to 60 degrees and the baseline varied through 10, 20 and 50 cm. This was repeated several times.

### 2.2.4 Drift/Stability Tests

Tests of 1 to 24 hours duration were performed with combinations of antenna separation, roll and pitch angle. More than 100 hours of data was recorded for each of the receivers during these tests.

### 2.2.5 Ice/Snow Masking

The mockups and antennas were surrounded or covered with snow and ice to depths up to approximately 12 inches above the tops of the antennas. Some antenna masking using an aluminum plate was also attempted.

A total of 105 hours of data was recorded from each receiver during the trials at CFS Alert over a 10 day period. Much of the data was reviewed using a 'FASTPLOT' routine to detect problems and modify test sequences to investigate interesting phenomena. Photographs of some of the test equipment are shown in Figures 8, 9, 10, and 11.

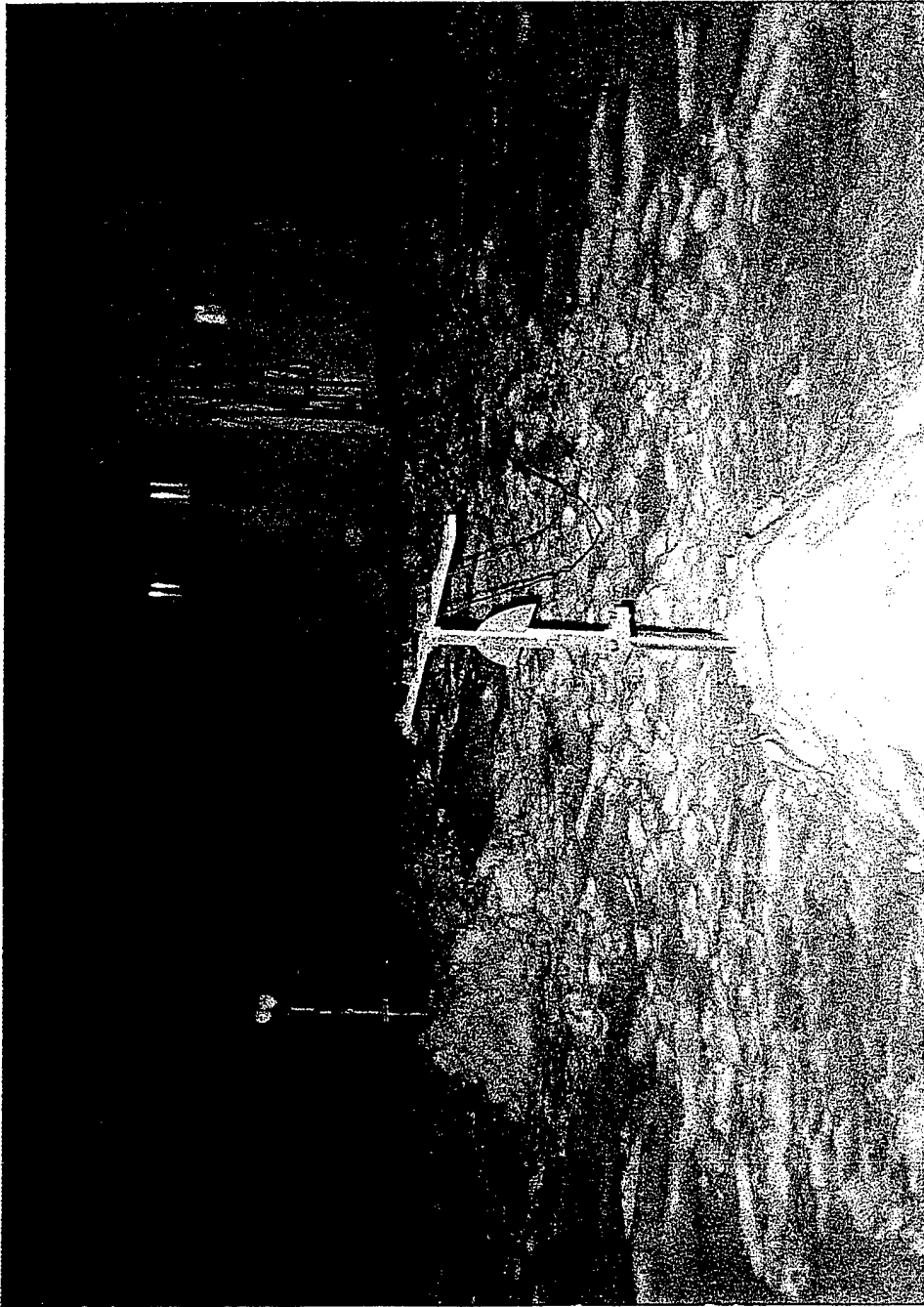

Figure 8. DREO NavLab Shelter at Alert with VP Oncore Antennas, foreground; and CMT 8700 Antennas, background

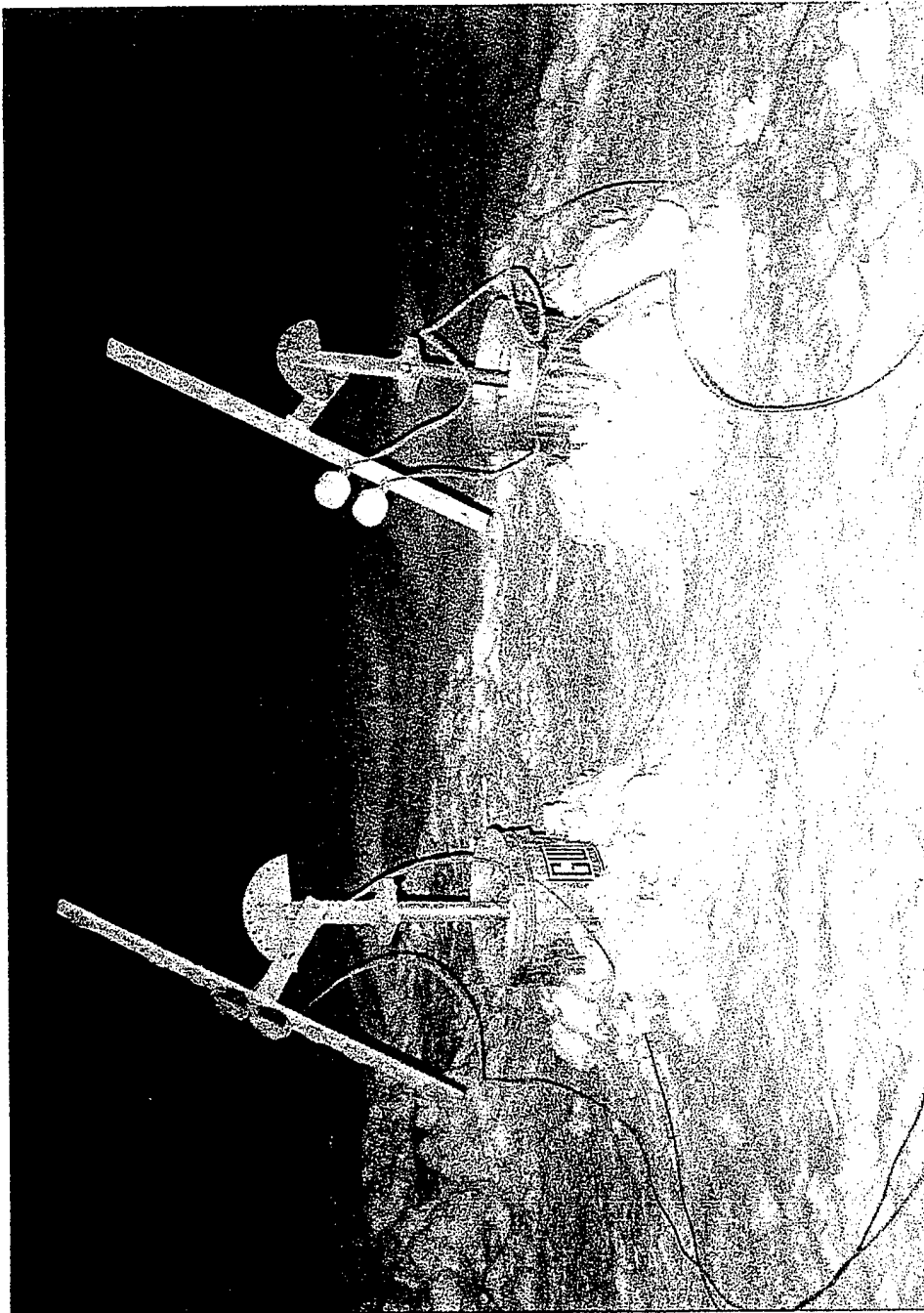

Figure 9. Antenna - pairs Pitched to 60° Degrees

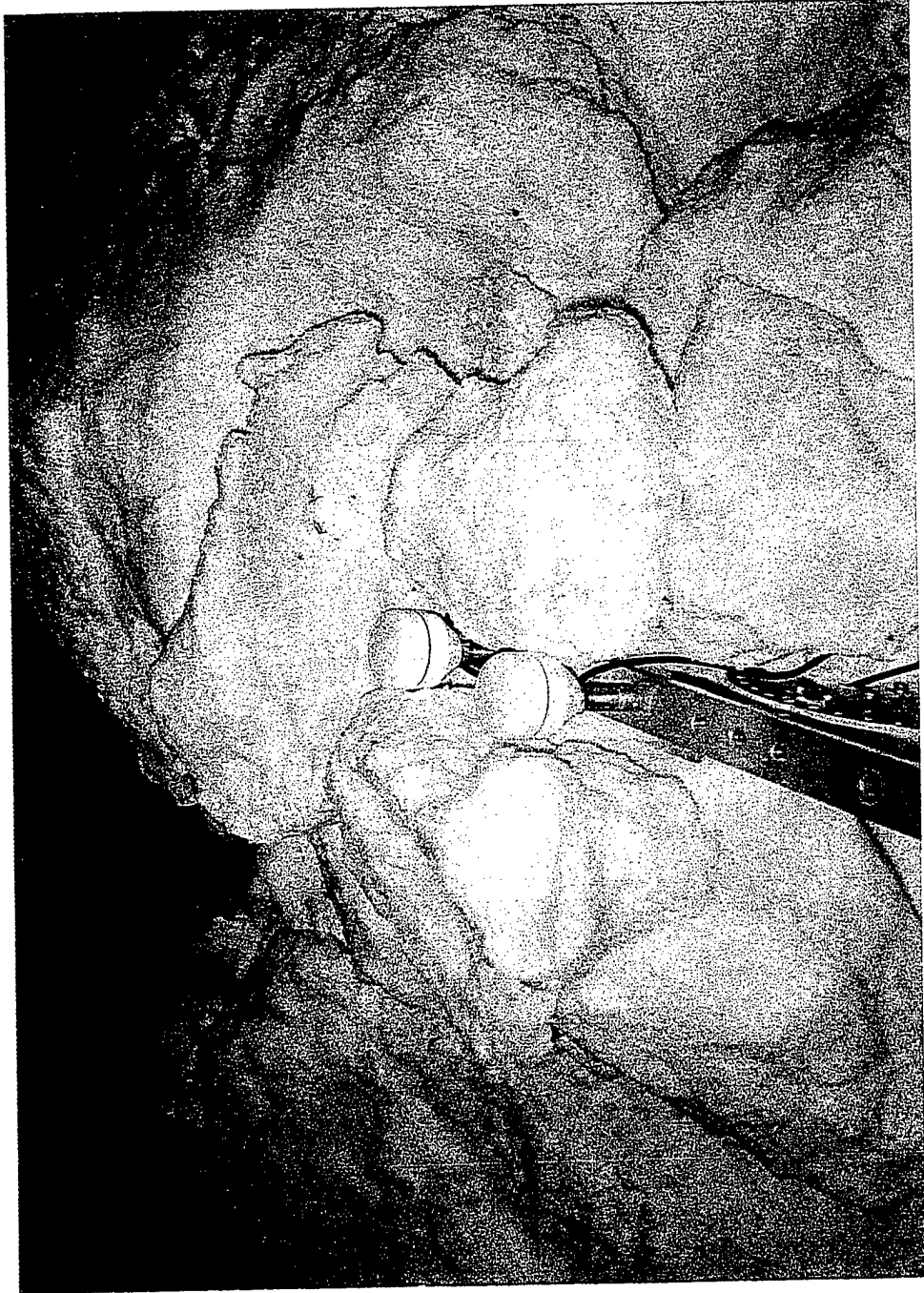

Figure 10. CMT 8700 Antennas with Snow Cover

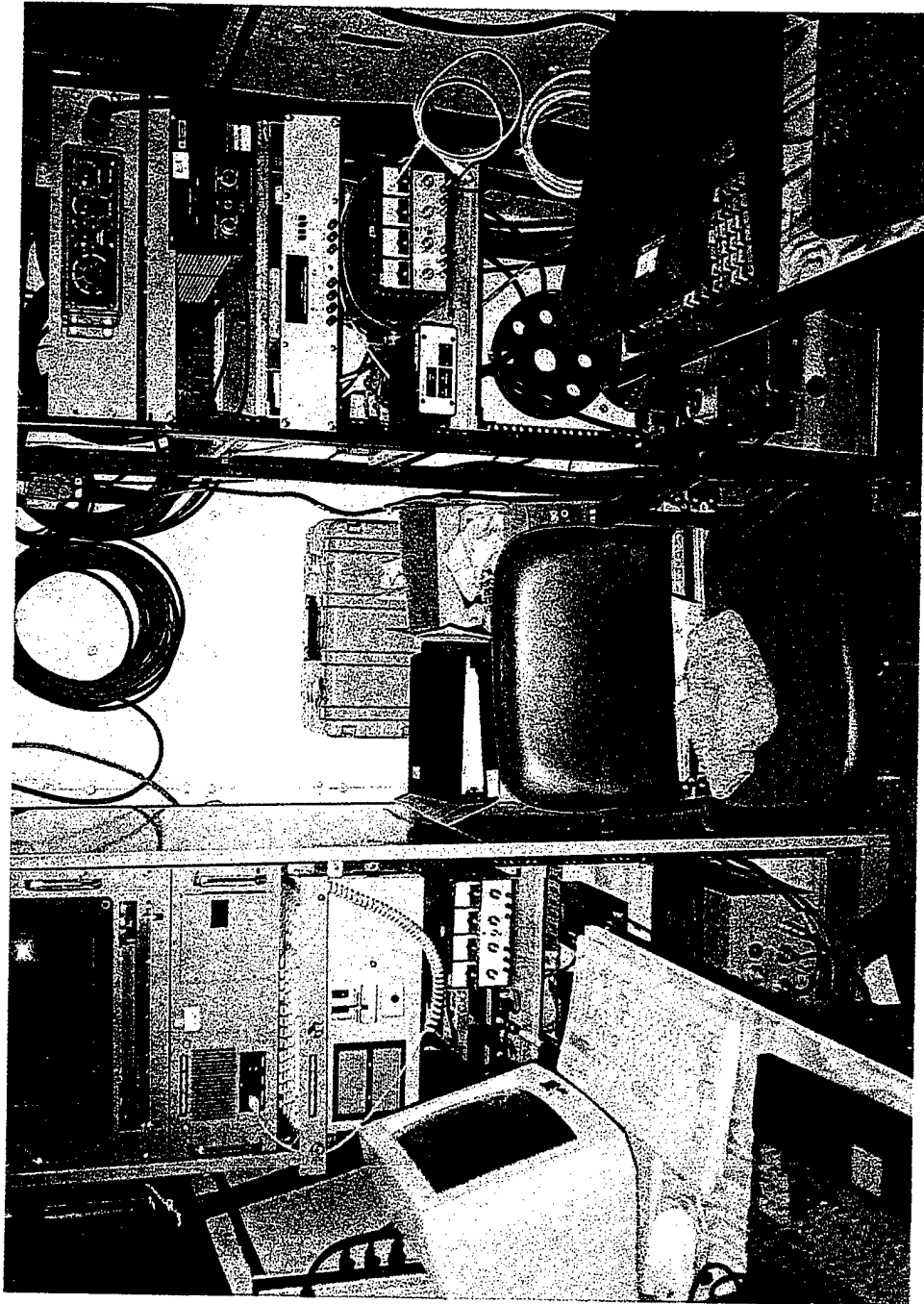

Figure 11. Data Logging Systems in DREO Shelter During CFS Alert Trials.

### 3.0 TEST RESULTS

The results for the two receiver pairs are presented in the following sections and then compared at the end of this chapter. The absolute accuracy of the derived heading from the two test systems was difficult to determine since it was too dark to employ optical survey reference equipment during the field trial. Nonetheless, angular measurements were made visually with respect to the reference systems, the Vector and gyrocompass, and there is no technical reason for any significant 'offsets' or errors to exist due to the use of GPS. The heading repeatability between successive tests was affected only by the physical handling of the antennas and support structures during adjustment of the antennas for each test.

#### 3.1 CMT 8700 Results

Figures 12, 13 and 14 are plots of heading and pitch at antenna separations of 10, 50 and 90 cm for the CMT 8700 GPS receiver pair. Note that the stability of the attitude solution increases with antenna separation and becomes less noisy due to reduced phase measurement noise. As can be seen in Figure 12, the noise in the heading is approximately 1.1 degrees and improves to 0.2 degrees at 90 cm. The pitch is somewhat noisier, which is to be expected since vertical (height) measurements are inherently more difficult to make due to the geometry of the satellites; all of the satellites are 'above' the antennas resulting in a poor Vertical Dilution of Precision (VDOP) as compared to the horizontal plane (HDOP). Again, the noise level drops as antenna spacing increases to 90 cm. Figure 15 is a similar plot of heading and pitch for an antenna separation of 10 cm but containing a dropout of approximately 4 minutes. Although the receivers were apparently functioning properly and providing data to HEAD, the attitude determination algorithm was unable to resolve the phase ambiguities, resulting in no available attitude solution during this time. The cause of such dropouts, usually of much shorter duration, is not precisely known and further investigation is continuing. Note that the heading uncertainty remains at approximately 1 degree for the 10 cm separation.

The effects due to pitching the antenna baseline to various angles are demonstrated in Figures 16, 17 and 18 for a baseline separation of 10 cm and pitch angles of 10, 30 and 60 degrees. Heading stability becomes somewhat worse at increased pitch angles and dropouts become more severe. The pitch measurement also becomes less certain with an error of several degrees at severe pitch angles of 60 degrees. This is due, in part, to the reduction in the number of

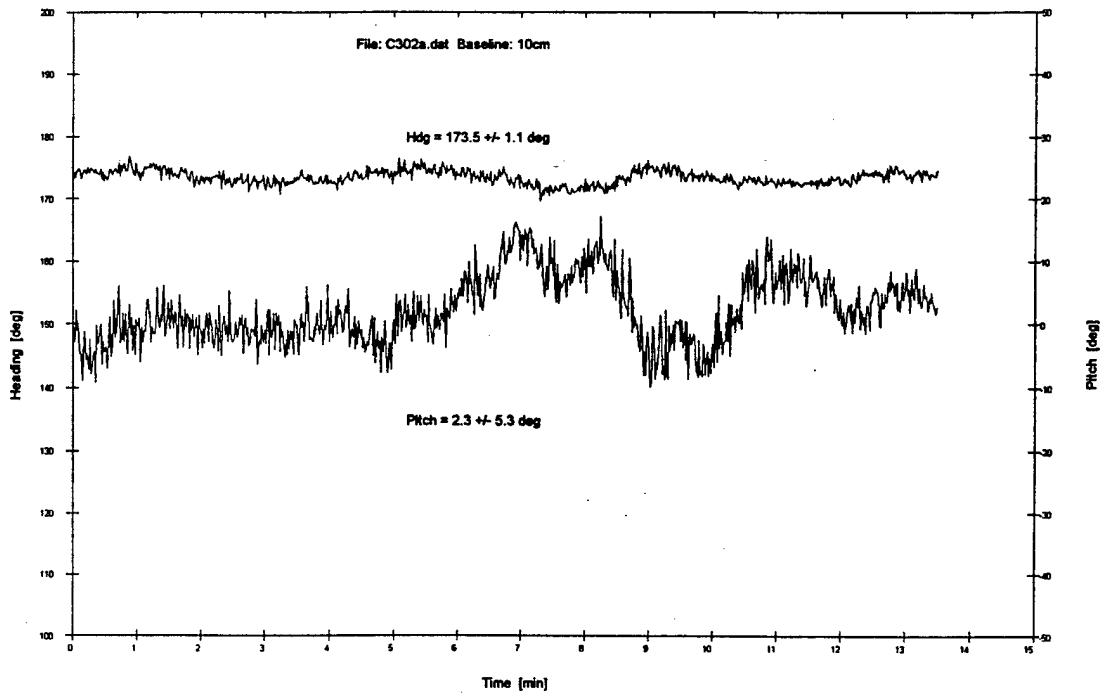

Figure 12: CMC 8700; Baseline = 10 cm

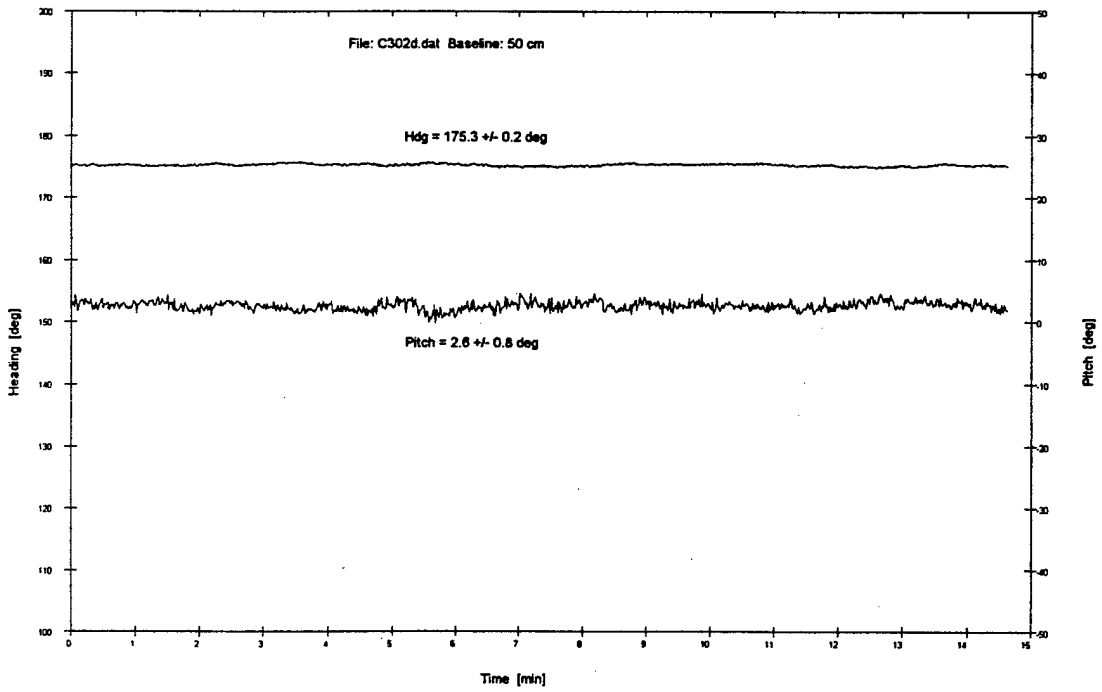
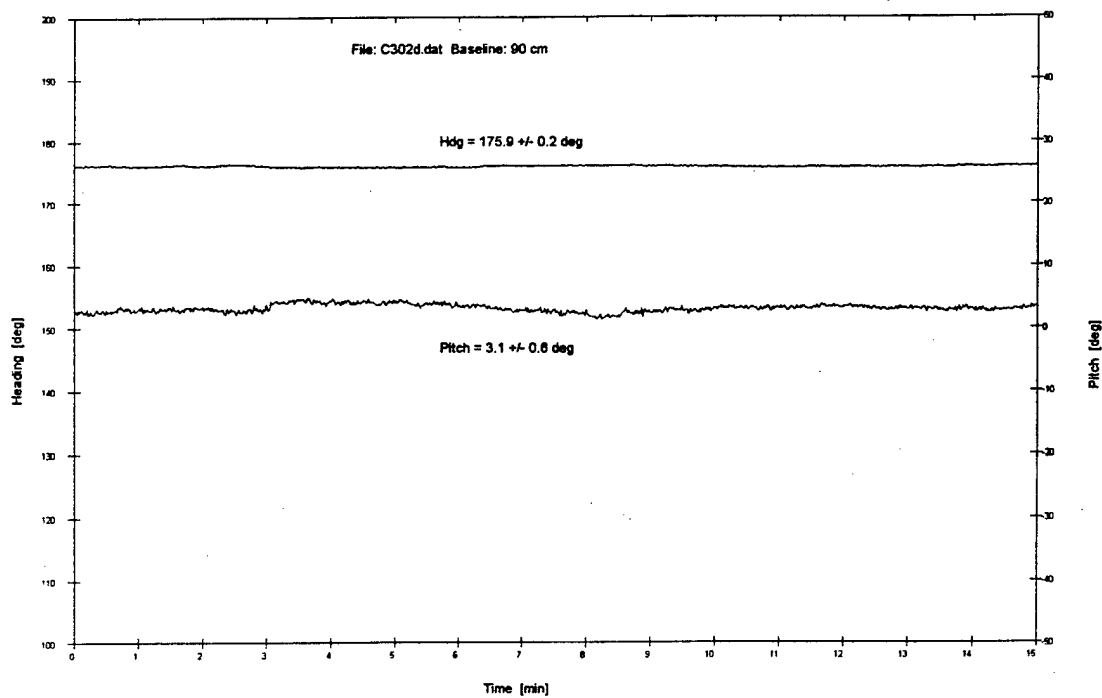
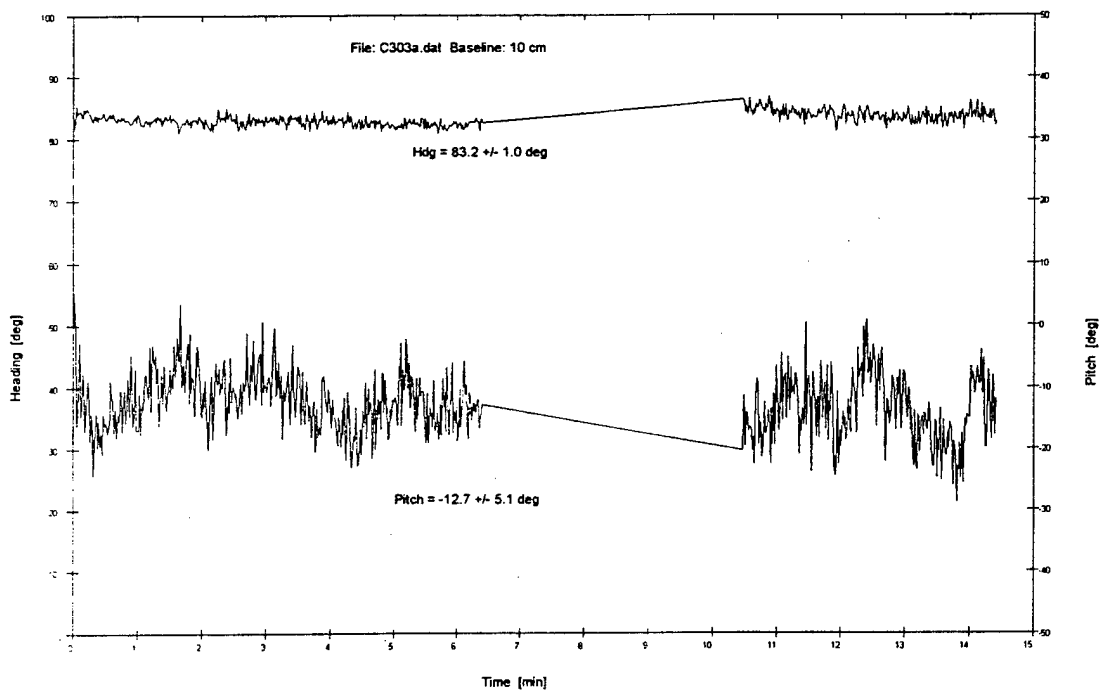

Figure 13: CMC 8700; Baseline = 50 cm



**Figure 14: CMC 8700; Baseline = 90 cm**



**Figure 15: CMC 8700; Baseline = 10 cm, approximately 4 minute dropout**

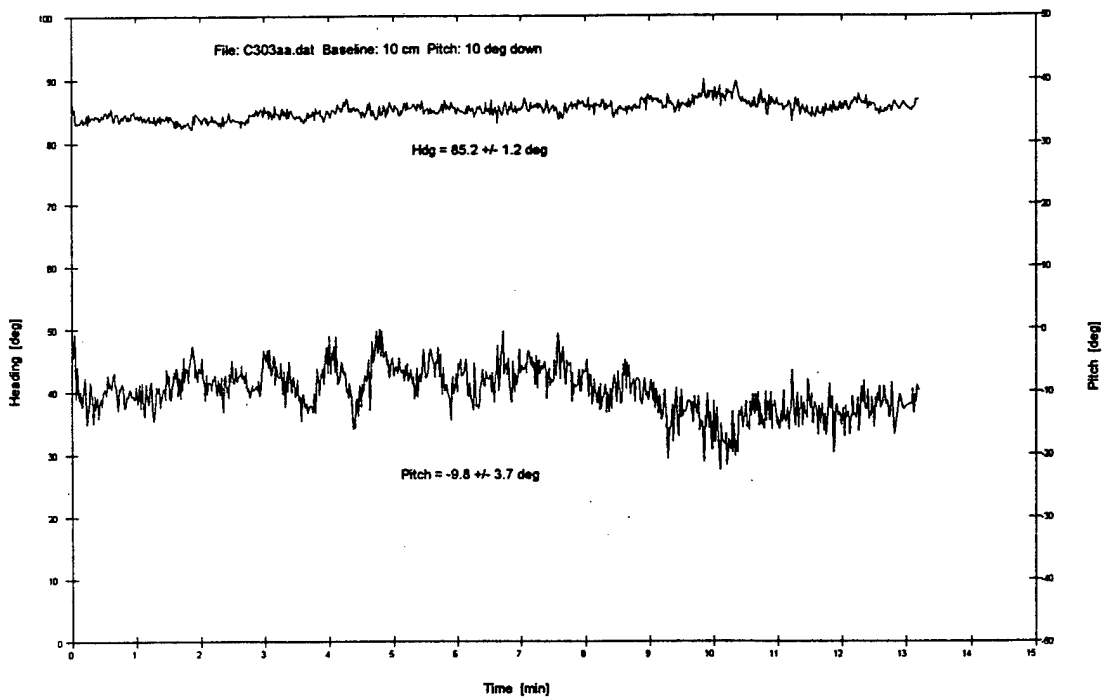

**Figure 16: CMC 8700; Baseline = 10 cm, Pitch = 10 degrees**

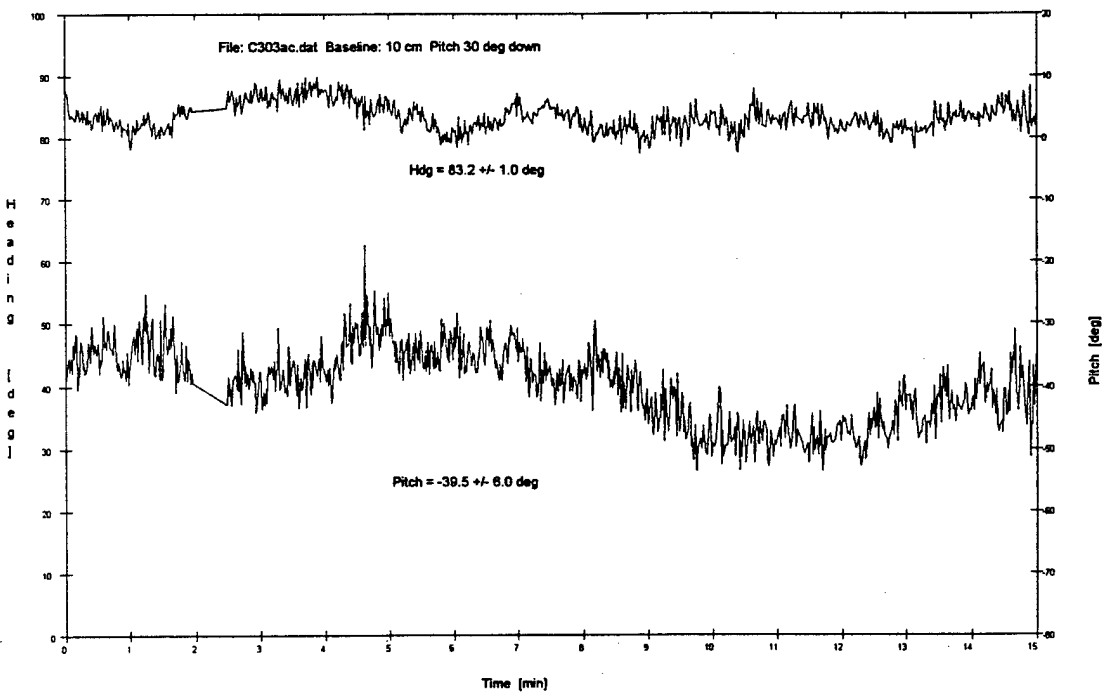

**Figure 17: CMC 8700; Baseline = 10 cm, Pitch = 30 degrees**

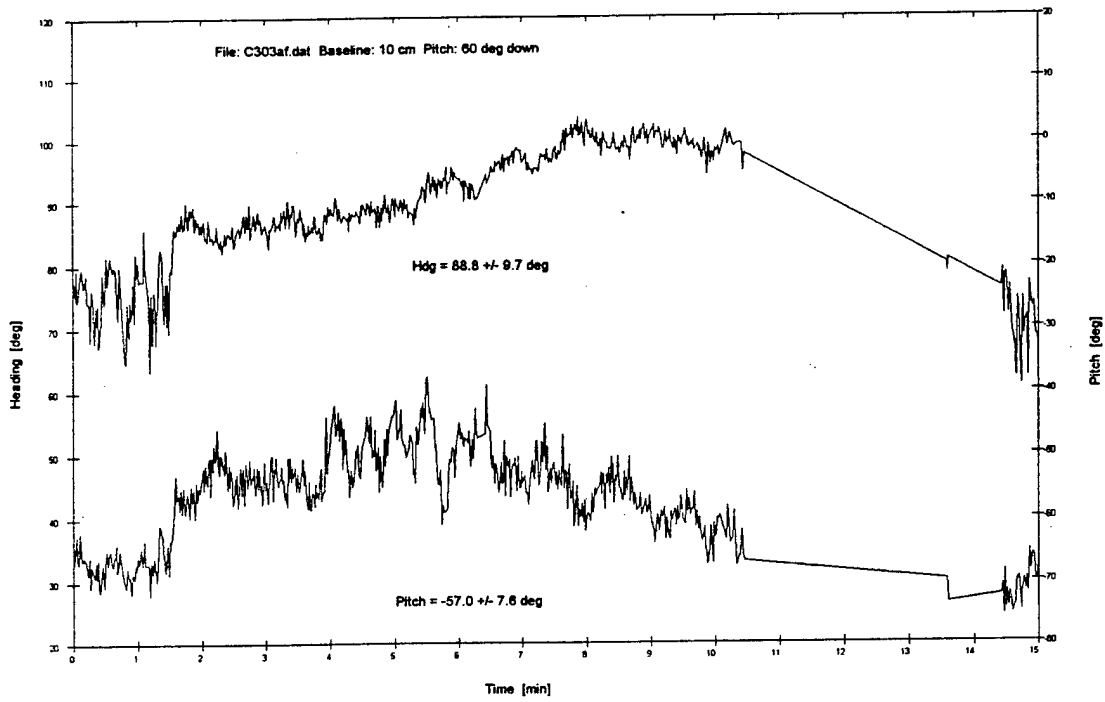

**Figure 18: CMC 8700 ; Baseline = 10 cm, Pitch = 60 degrees**

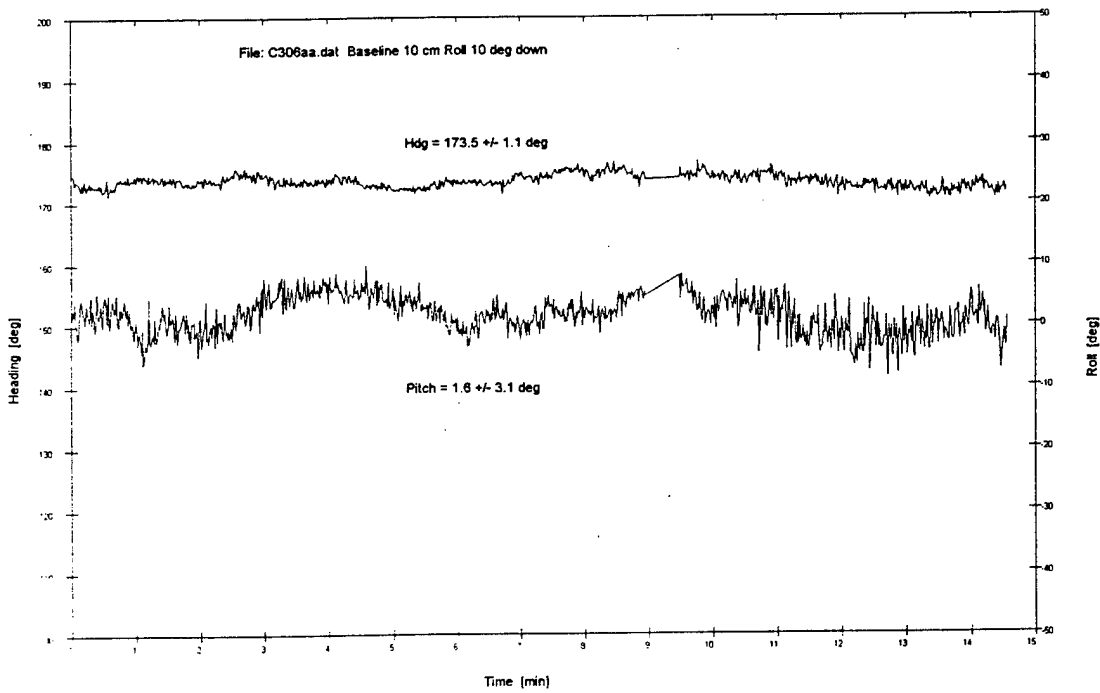

**Figure 19 CMC 8700; Baseline = 10cm, Roll = 10 degrees**

satellites available to the receivers due to antenna masking resulting in poorer apparent geometry (the antennas can't 'see' all of the available satellites since they have a hemispherical reception pattern and the pitch angle results in a masking of a portion of the sky). Similarly, Figures 19, 20 and 21 show similar effects when the antenna structure is rolled to angles of 10, 30 and 60 degrees. Note that dropouts also become more severe in terms of time and frequency at greater pitch and roll angles. In Figure 21, the system had great difficulty resolving the phase ambiguities for the 60 degree roll angle and the result is quite poor; in fact the pitch angle is **incorrect** being resolved at 20 degrees rather than 0 degrees although the heading is correct with a variation of less than 2 degrees.

The combined results for all baseline separations versus pitch and roll tests on the CMT 8700 receiver pair are summarized in Table 1. Note that pitch and roll results are combined in this table and are treated as having the same effect. Using the definitions from section 2.1, the time-to-resolution and the % availability are given in the first two columns. In general, the time-to-resolution is less than 20 seconds for baseline lengths of less than 20 cm and pitch/roll angles of less than 30 degrees. At larger roll and pitch angles, the time to resolution increases appreciably, to 60 seconds or more and dropouts, as discussed, increase significantly. Time-to-resolution can be expected to increase with increased baseline, in part due to the fact that multipath effects become decorrelated with increasing distance between antennas resulting in longer times to resolve phase ambiguities. Availability is between 82 and 96 percent for all tests as shown in column 3 and appears to indicate that availability is actually higher at greater antenna separations. This is generally true but it should be noted that the increased time to resolution reduces the 'data set' from which the availability calculation is made and this term also does not take into account whether or not the heading and pitch are **correct**. Both time-to-resolution and % availability are functions of the performance of the HEAD algorithm and, as such, may improve as HEAD is developed. Note also from Table 1 that the heading uncertainty is less than 5 degrees in all cases.

The standard deviations shown in the table appear excessively large. This is simply due to the fact that there were several extremely poor results for which we had no obvious explanation and, as such, were included in the statistical calculations as being valid data.

It should be recalled from our earlier definition of availability that we did not define % availability as the

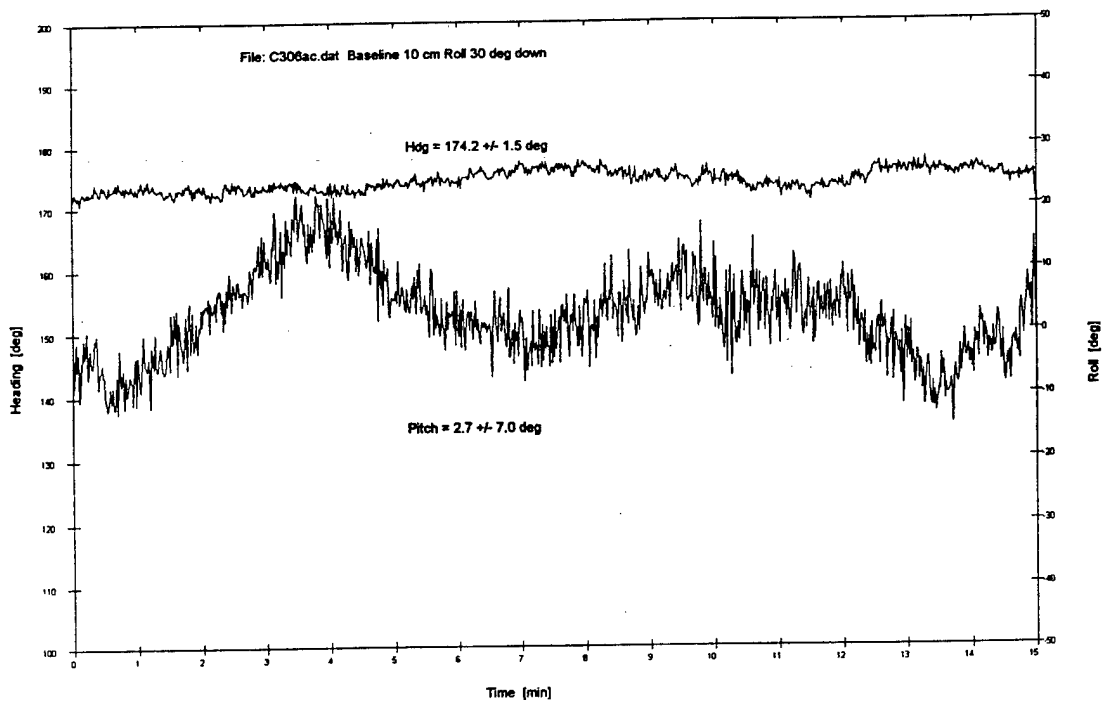

Figure 20: CMC 8700; Baseline = 10 cm, Roll = 30 degrees

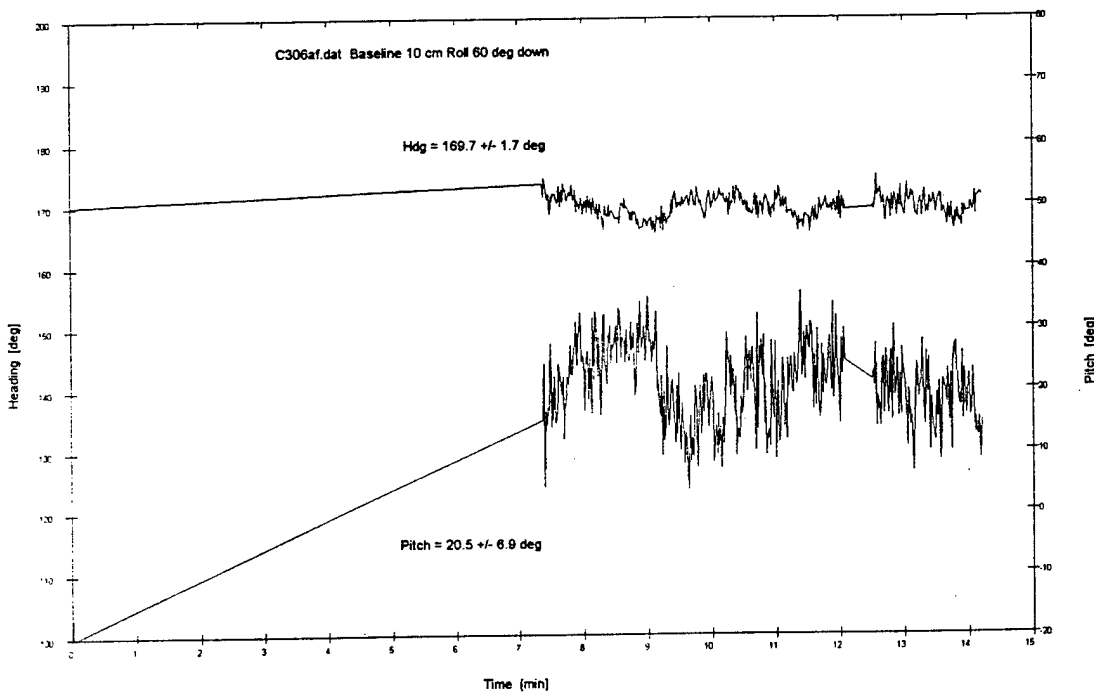

Figure 21: CMC8700; Baseline = 10 cm, Roll = 60 degrees

Baseline [cm]	Time to Resolution [sec]  mean & SD	Availability [%]  mean & SD	Heading	
			East [deg]  mean & SD	South [deg]  mean & SD
10	3.1±10.7	85.9±15.7	83.9±2.2	171.8±2.0
20	15.4±52.8	82.8±25	84.4±2.17	173.7±1.1
30	49.4±59.3	96.0±9.0	83.1±0.9	173.0±1.4
50	62.2±128	88.8±17.6	83.7±4.0	173.5±0.6
90	41.3±51.2	96.2±4.9	86.3±0.3	174.1±1.0
Summary	28.2±82.2	85.7±20.9	83.8±2.37	173.1±1.6

**Table 1** Canadian Marconi CMT-8700 GPS Receiver Heading Data Summary

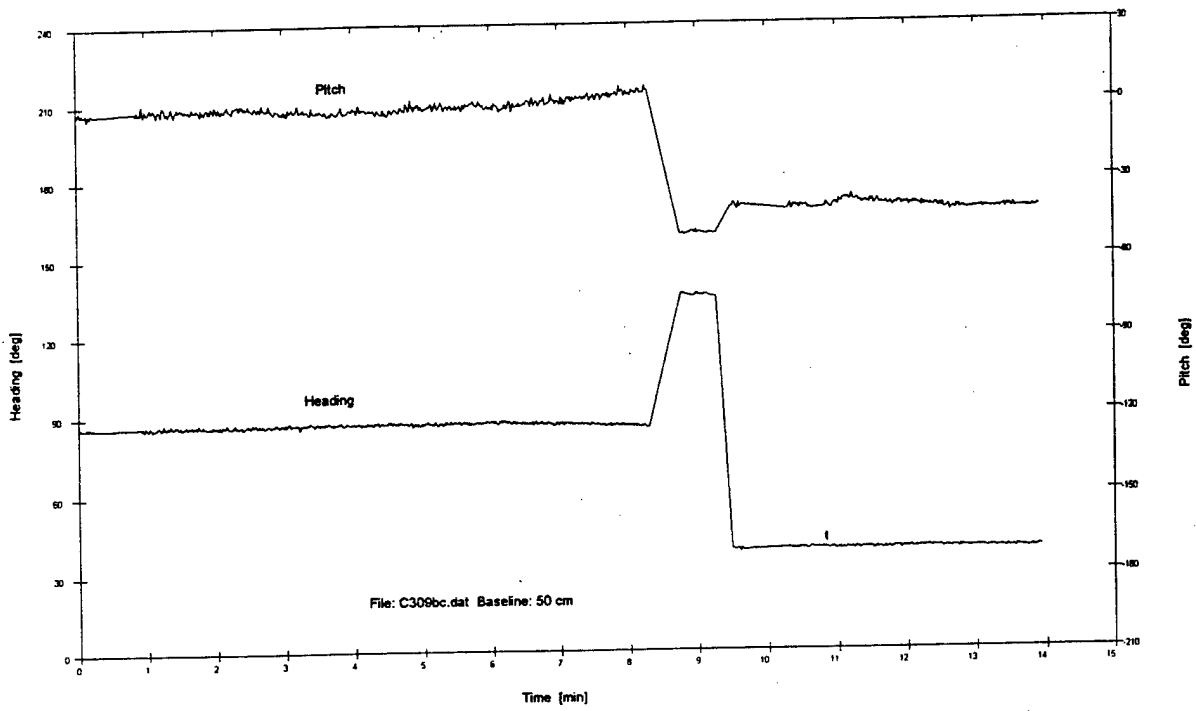

Figure 22: CMC 8700; Multistable Output

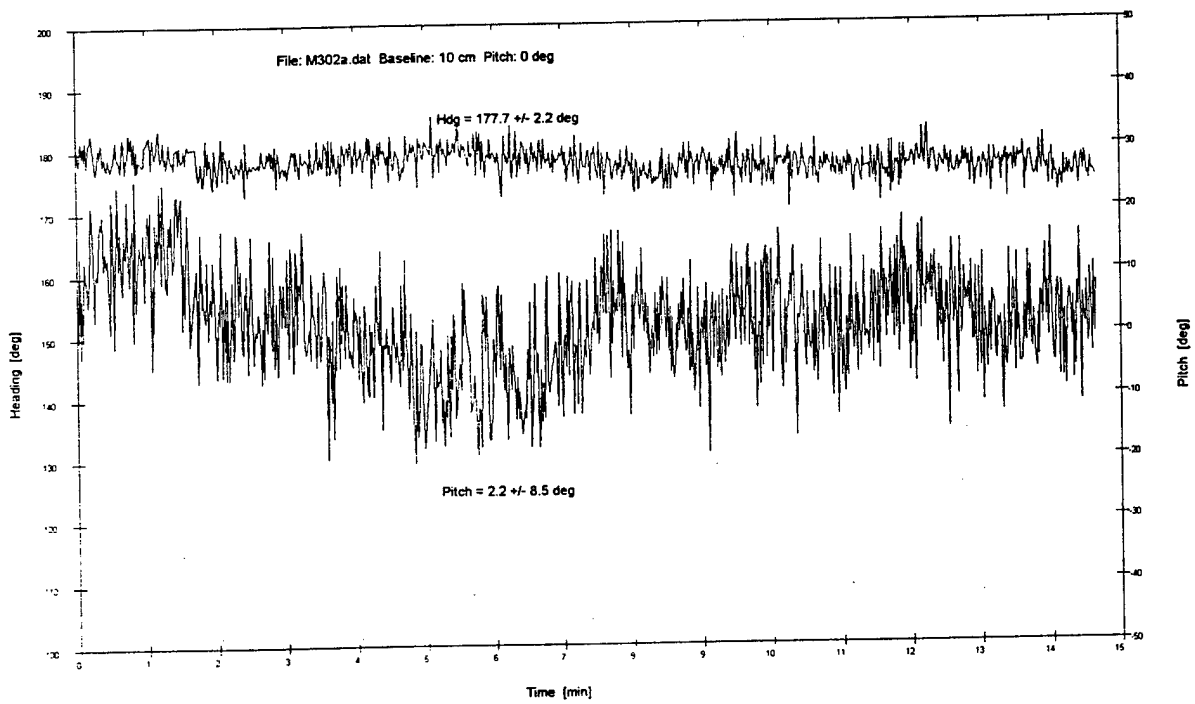

Figure 23: Motorola VP Oncore; Baseline = 10 cm

time during which correct attitude is provided but rather the time during which any attitude is provided. This is important since, without the aid of an external reference, the user can never be totally confident that the system is providing the correct heading, and there is, in fact, no way for HEAD to do so either without external aiding. An incorrect attitude output appears in output data as the (previously-defined) multistable effect. This effect results from an incorrect determination of the integer number of phase cycles between the two antennas and is caused by several phenomena including receiver phase noise and multipath effects. An example of this is shown in Figure 22 where the heading remains stable at one value for a period of time then loses lock and reacquires at another value. In order to determine the magnitude of this problem, the data files were reprocessed with the correct heading (as determined by the external reference system used during the trials) and the percentage of time that incorrect attitude was determined by HEAD was recorded. The actual occurrence of this phenomenon was determined to be 2.0 percent of the total availability. This is a significant proportion of the time and will have operational implications. This problem will continue to be investigated in consultation with the University of Calgary.

The effects of snow and ice cover and shielding were found to be somewhat uncertain since some results were very good yet other tests showed increases in noise and dropouts. Repetition of these tests under more controlled conditions should be considered in any future work. Intuitively, one would expect a decrease in satellite signal strength due to snow or ice cover resulting in some loss of performance.

The effects of satellite availability and geometry in the Canadian Arctic were studied during the data analysis. It was noted during the trials that both the CMC and Motorola receivers, with 12 and 8 channels respectively, tracked satellites on almost all channels most of the time; the CMT 8700 tracking 11 satellites on a regular basis. The PDOP, as predicted in Figures 5 and 6, was adequate to enable virtually optimum receiver performance. No significant satellite geometry or availability problems were noted although the use of all-in-view receivers would be preferable to ensure optimization of available geometry in any case.

### **3.2 Motorola VP Oncore Results**

For comparison purposes, results at the same antenna separations and roll/pitch angles as those presented for the CMT 8700 are presented for the VP Oncore receivers. Although both receiver types functioned well during the trials and

experienced similar performance, there are some notable differences.

Figures 23, 24 and 25 are plots of heading and pitch for antenna separations of 10, 50 and 90 cm. The attitude solution for this receiver is somewhat noisier than the CMT 8700 at the same antenna separations. This was true of all results for this receiver. This is most likely due to the quality of the phase measurement provided by the receiver and, as such, will be a point of comparison when selecting a receiver for this application. There is also a significant dropout in the 90 cm plot of Figure 25 and, again, there were somewhat more dropouts seen in the VP Oncore data as compared to the CMT 8700. Again, the attitude solution improves at larger antenna separations, as expected. Noise levels for these results remained at less than 2.5 degrees in heading.

The performance during pitching of the antenna structure are shown in Figures 26, 27 and 28 for a 10 cm separation and pitch angles of 10, 30 and 60 degrees. Again, attitude performance is much noisier than the CMT 8700 receiver and more dropouts are apparent; in fact, at a 60 degree pitch, the heading uncertainty is over 10 degrees! Similarly, Figures 29, 30 and 31 are plots of attitude output at roll angles of 10, 30 and 60 degrees for a 10 cm antenna separation. Results are comparable to the pitch performance and the same comments apply.

Table 2 is a summary of all results from the VP Oncore receiver and can be directly compared to Table 1 with the same comments applying with respect to the large standard deviations. The time-to-resolution is actually shorter for the VP Oncore than for the CMT 8700 in almost all cases but % availability drops off at antenna separations greater than 30 cm and increased pitch and roll. Similarly, the heading uncertainty becomes larger than 5 degrees at larger antenna separations. The percentage of time that incorrect attitude data is available for the VP Oncore is 7.1 %, Significantly higher than the CMT 8700. This is believed to be a result of the apparently noisier phase measurements available from the VP Oncore resulting in greater difficulty resolving the phase ambiguities. Again, this problem continues to be investigated.

As in the case of the CMT 8700, snow and ice cover effects were inconclusive with some apparent increase in multistable output and somewhat longer and more frequent dropouts, particularly at longer antenna baseline separations and large pitch and roll angles. Again, this warrants further controlled study.

Baseline [cm]	Time to Resolution [sec]  mean & SD	Availability [%]  mean & SD	Heading	
			East [deg]  mean & SD	South [deg]  mean & SD
10	1.2±2.8	89.5±14.7	88.6±2.9	177.3±2.7
20	11.4±35.4	81.7±20.5	88.6±2.2	176.7±1.1
30	8.8±4.0	93.4±10.2	85.9±0.5	176.5±0.2
50	23.8±52.9	76.8±24.5	86.8±5.0	176.8±4.2
90	44.5±71	77.7±36.4	123.9±53.2	177.3±0.2
Summary	13.1±38.5	82.7±21.0	88.0±2.54	177.2±2.76

**Table 2** Motorola VP Oncore GPS Receiver Heading Data Summary

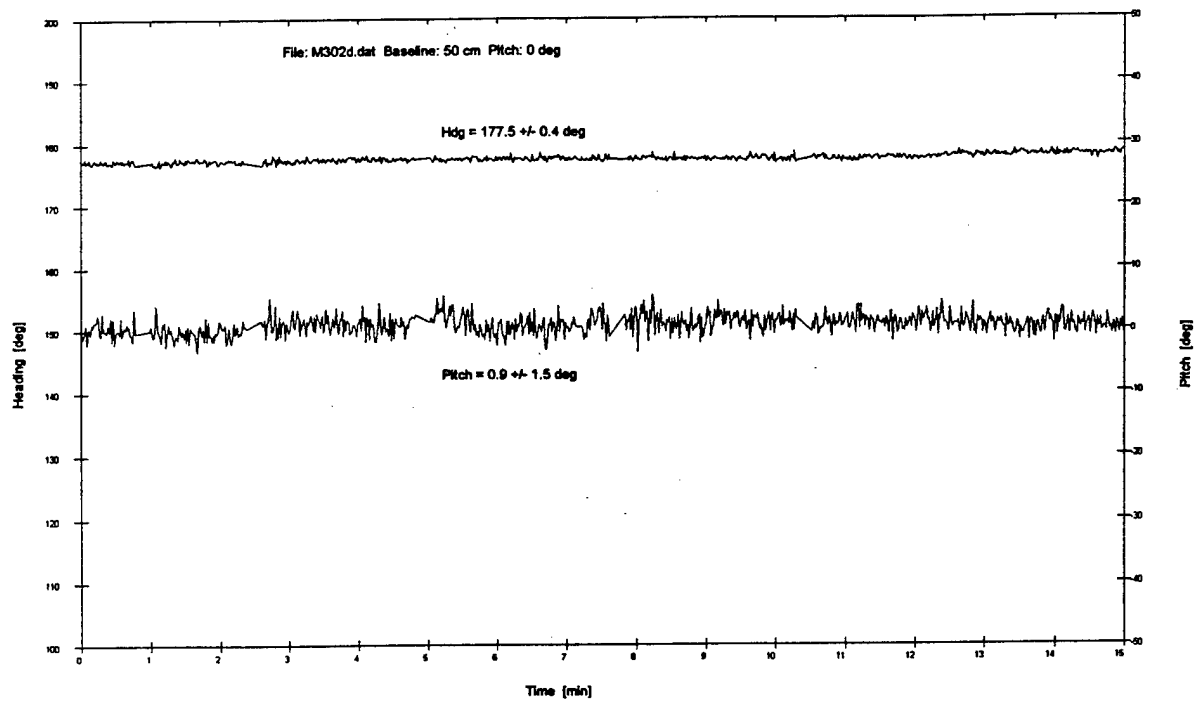

Figure 24: Motorola VP Oncore; Baseline = 50 cm

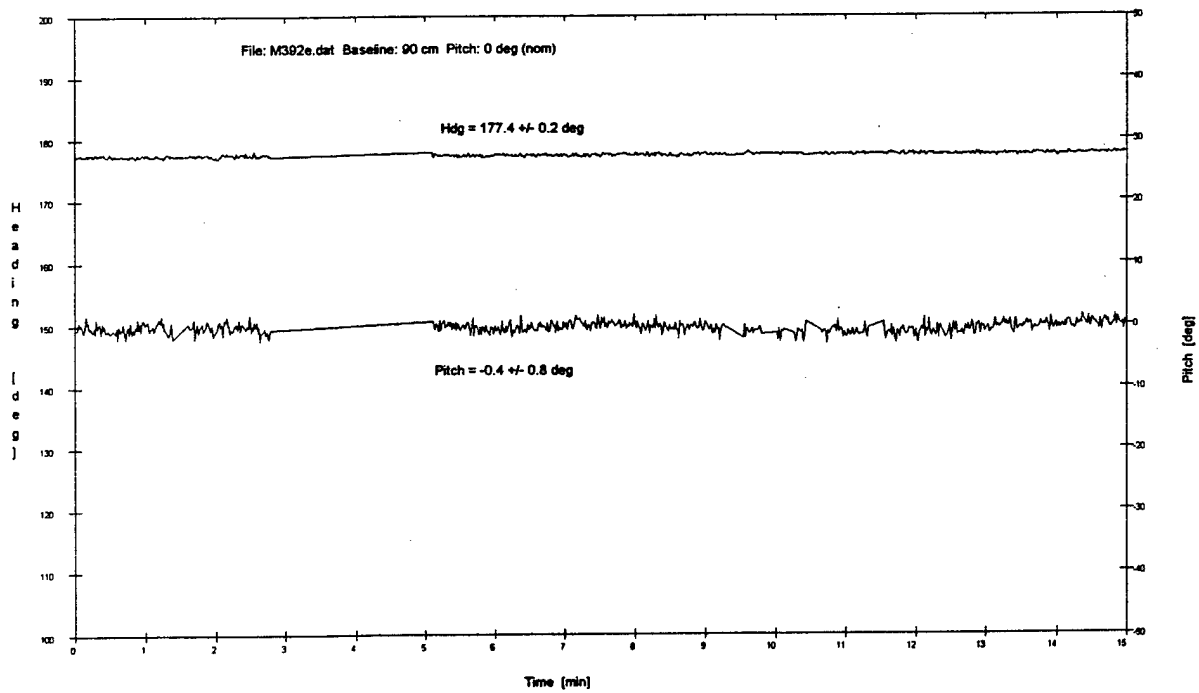
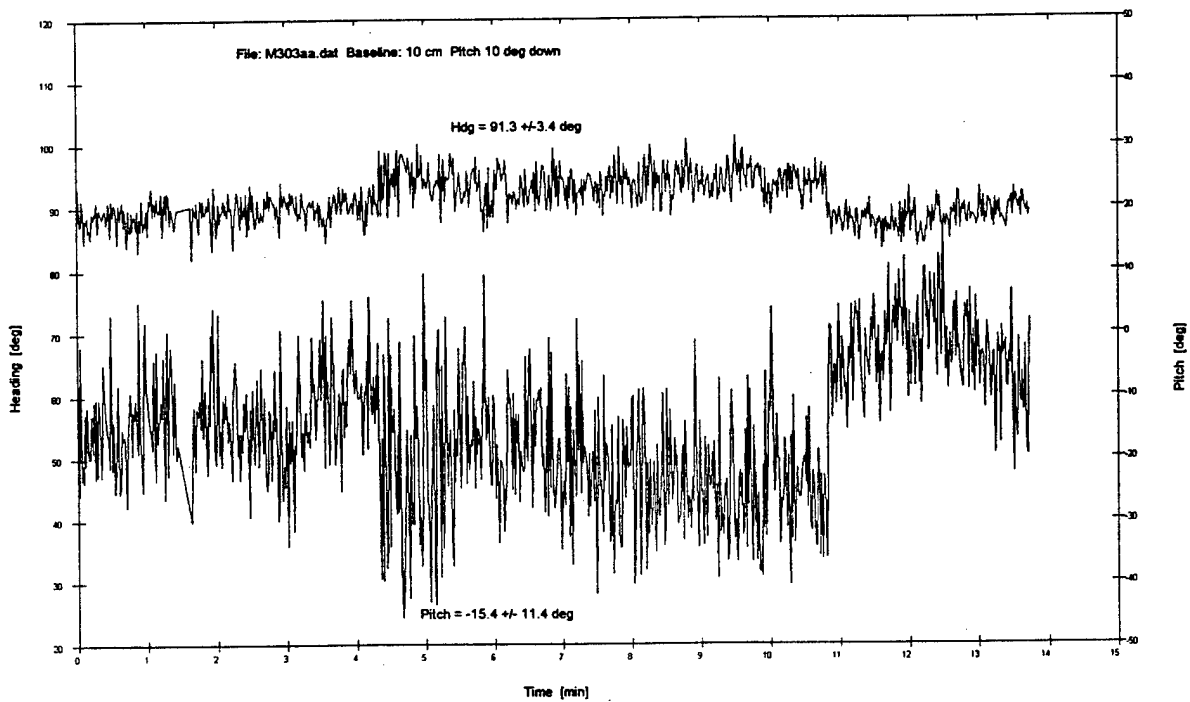
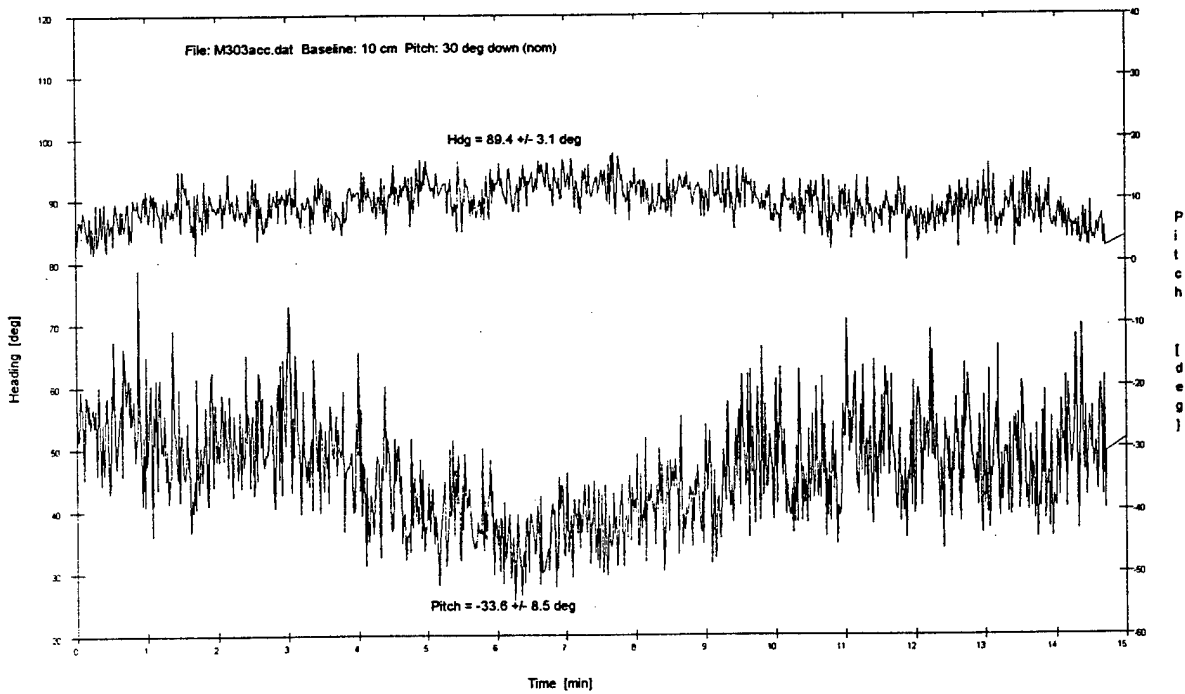

Figure 25: Motorola VP Oncore; Baseline = 90 cm



**Figure 26: Motorola VP Oncore; Baseline = 10 cm, Pitch = 10 degrees**



**Figure 27: Motorola VP Oncore; Baseline = 10 cm, Pitch = 30 degrees**

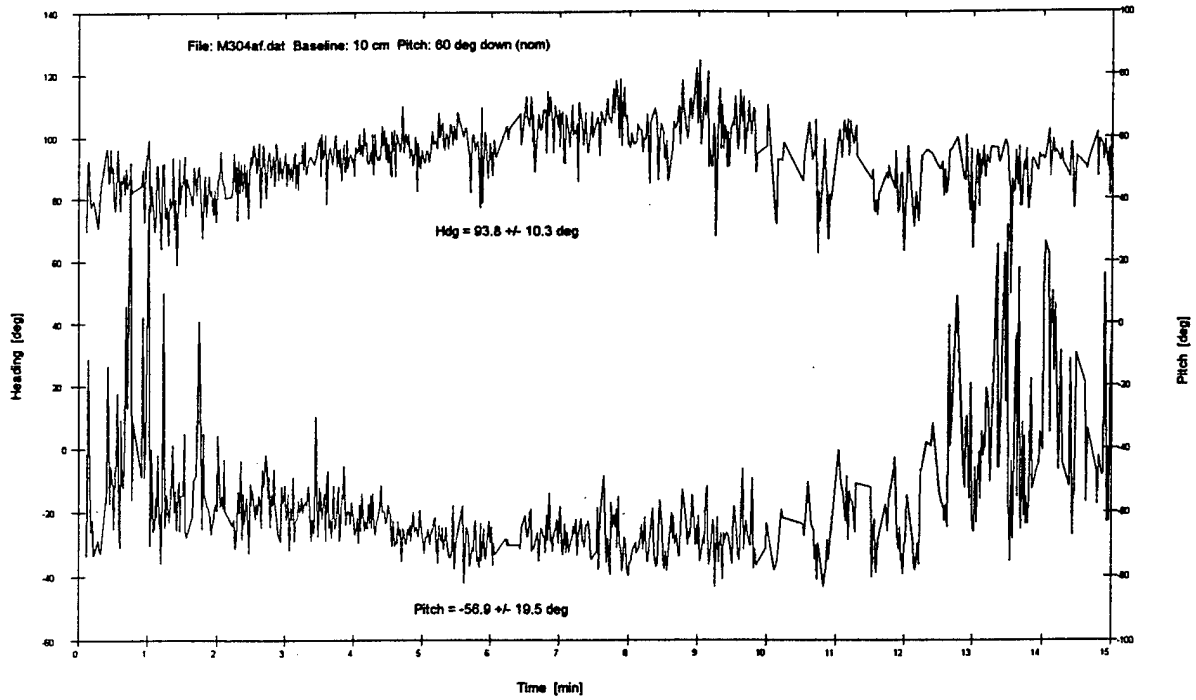

**Figure 28: Motorola VP Oncore; Baseline = 10 cm, Pitch = 60 degrees**

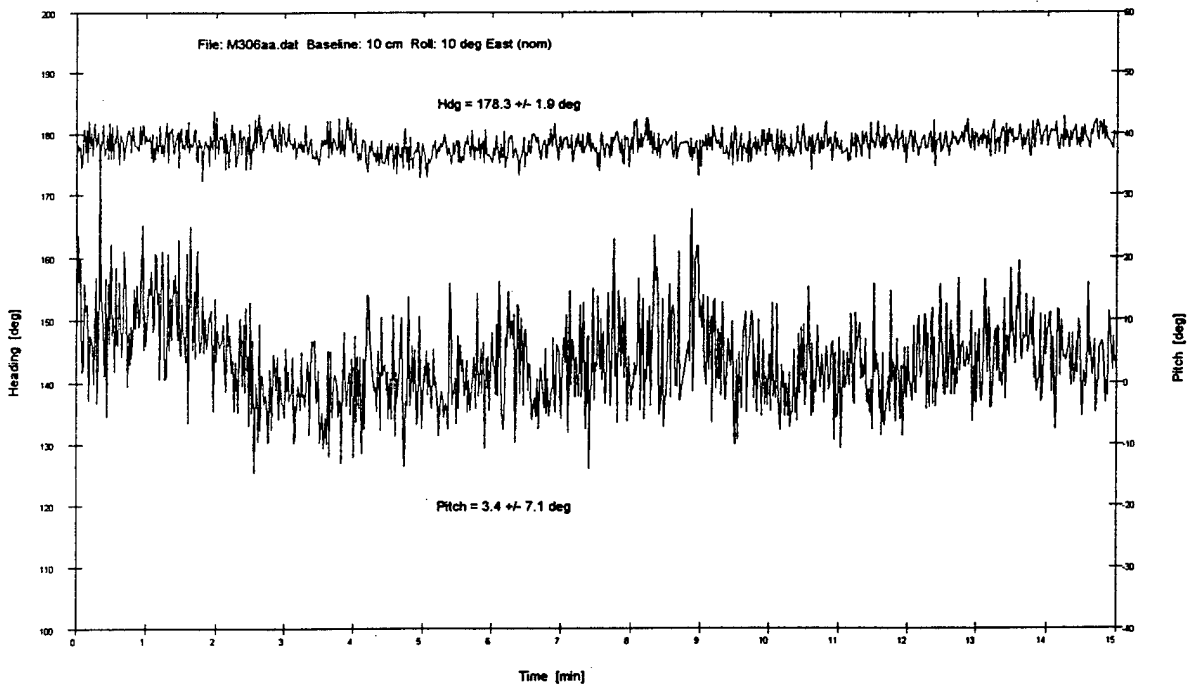

**Figure 29: Motorola VP Oncore; Baseline = 10 cm, Roll = 10 degrees**

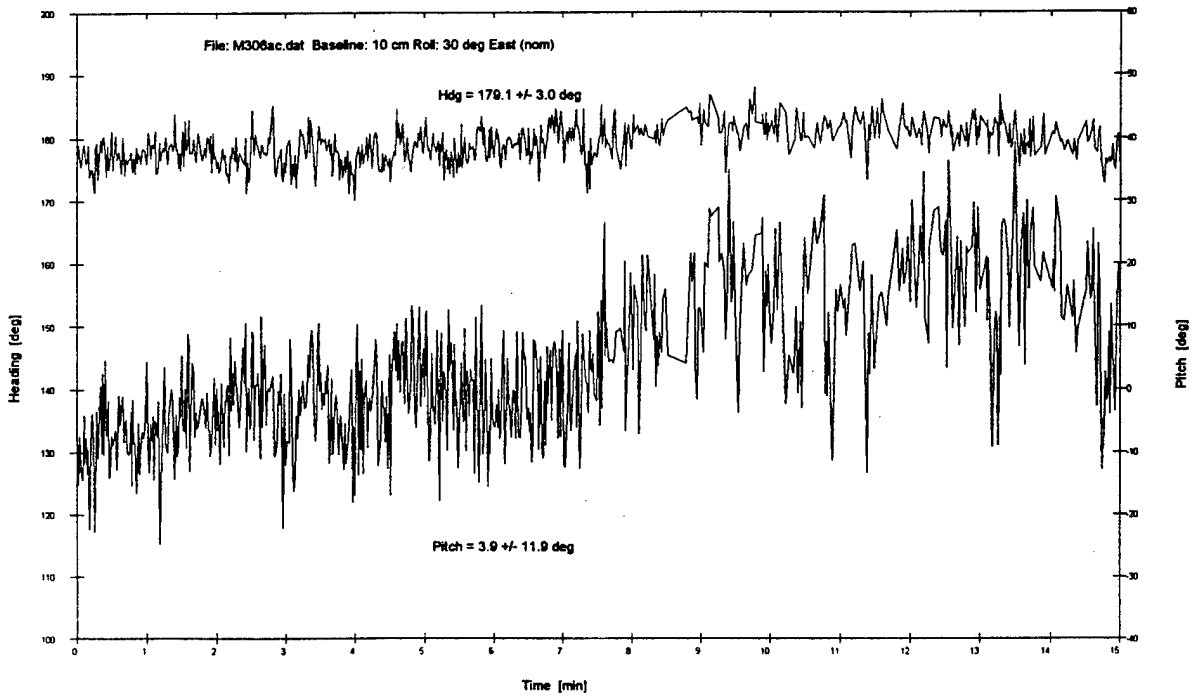

**Figure 30: Motorola VP Oncore; Baseline = 10cm, Roll = 30 degrees**

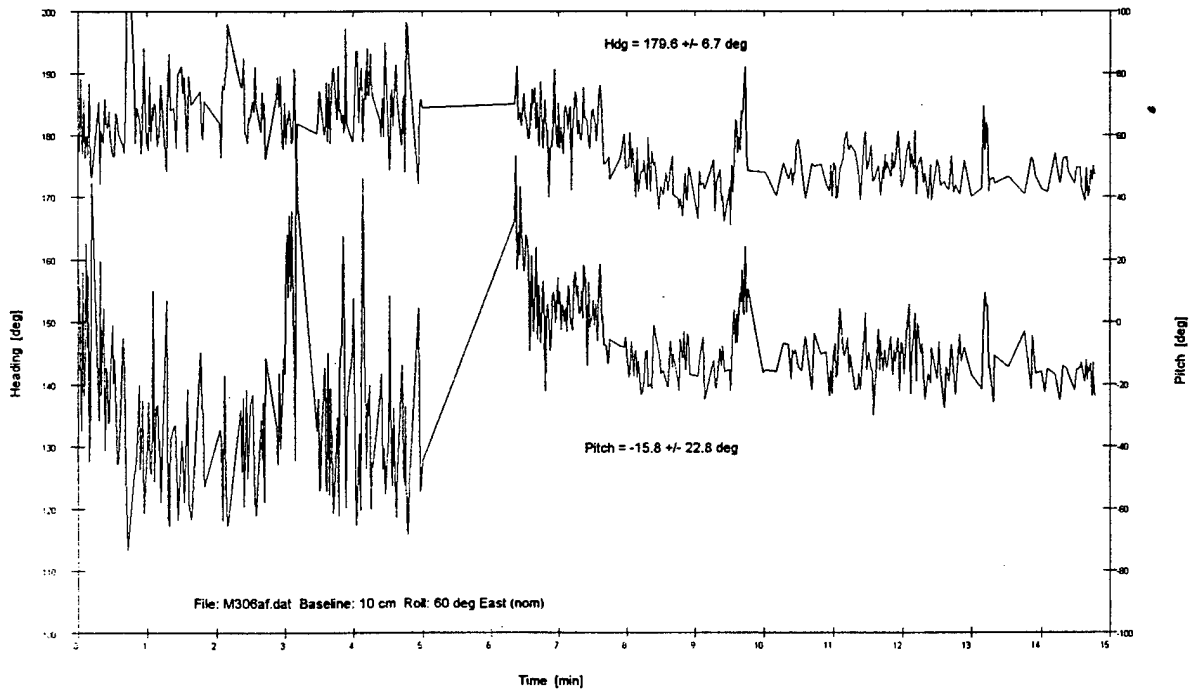

**Figure 31: Motorola VP Oncore; Baseline = 10 cm, Roll = 60 degrees**

### 3.3 Summary of Results

The Arctic field trial exercised two off-the-shelf receiver designs from different manufacturers but employing an attitude determination algorithm developed by the University of Calgary and licenced to DREO. In general, this algorithm could accept the code and phase data from any given receiver pair ( in the appropriate format ) and determine the heading and pitch of the baseline separating the antennas. The CMT 8700 and the VP Oncore underwent identical tests at identical times and the results are detailed above. Figure 32 is a plot of some typical reference system data provided by the Vector attitude determination system and the gyrocompass. Note that the Vector provided both pitch and roll results to better than 0.15 degrees at all times and the gyrocompass was stable to 0.02 degrees. Data was recorded continuously from both of these references and no dropouts or multistable results occurred. Figure 33 is a plot of the actual PDOP as determined by the Vector receiver and calculated from the geometry of the actual satellites in view during the same period as the plot in Figure 32. The average PDOP is 5.1 although some excursions are apparent in the figure.

For comparison purposes, Figure 34 shows the standard deviation of heading as a function of baseline length between antennas. The plot denoted as Fx is the approximate theoretical performance one could expect as defined in Reference [4]. The CMC 8700 results were better than the VP Oncore in all cases at short antenna separations and substantially better at the 10 cm separation. Since the Vector was used as a static reference system (the antennas were not moved at any time), there is only one point on the plot for the Vector, at a 1.5 meter separation.

Table 3 summarizes the results of the tests on the CMC 8700 and VP Oncore receivers. Both receiver pairs met the heading determination requirement of 5 degrees under 'benign' test conditions of up to 30 degrees in pitch and roll for all antenna separations although the CMC 8700 results were less noisy in all cases. Under more extreme conditions of greater pitch and roll angles, the VP Oncore results were much noisier, had longer dropouts, increased time-to-resolution and had more multistable outputs.

One additional area of interest should be discussed at this point; that is, the performance of the individual receivers with respect to navigation positioning capabilities. Some interesting results were obtained from some of the overnight tests where the receivers were left on and data was recorded for 12 to 16 hours at a time. The receiver position (latitude/longitude/altitude) was plotted

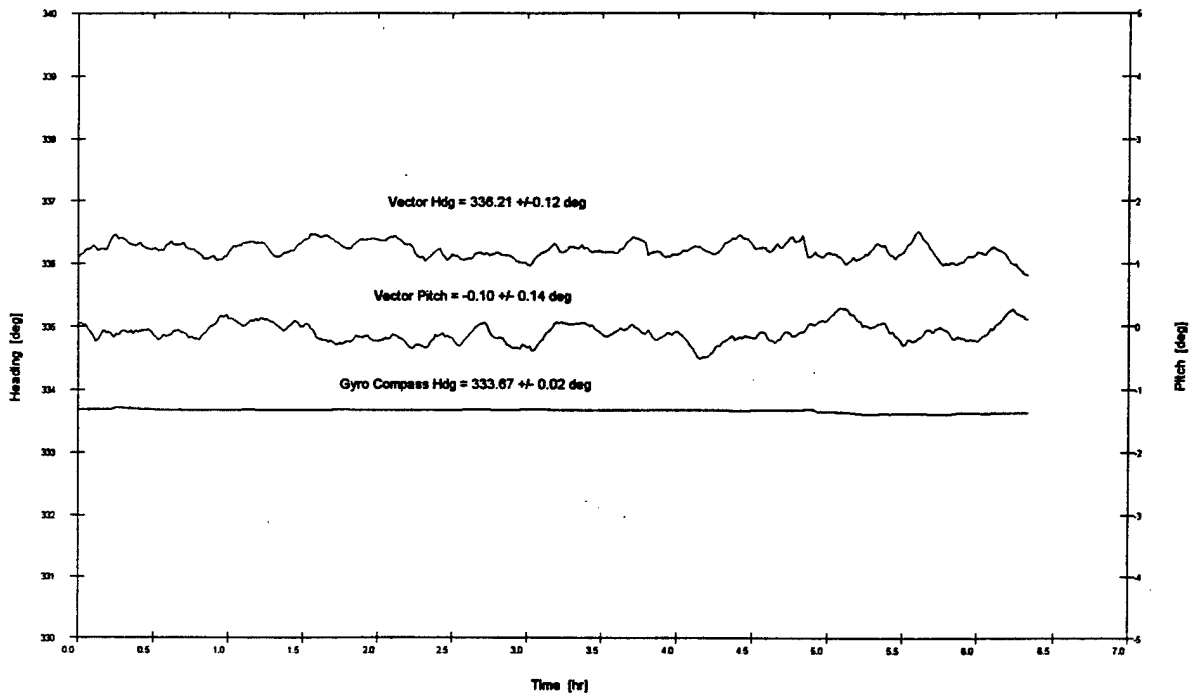

**Figure 32: Trimble Vector and Arma-Brown Gyrocompass Reference Data**

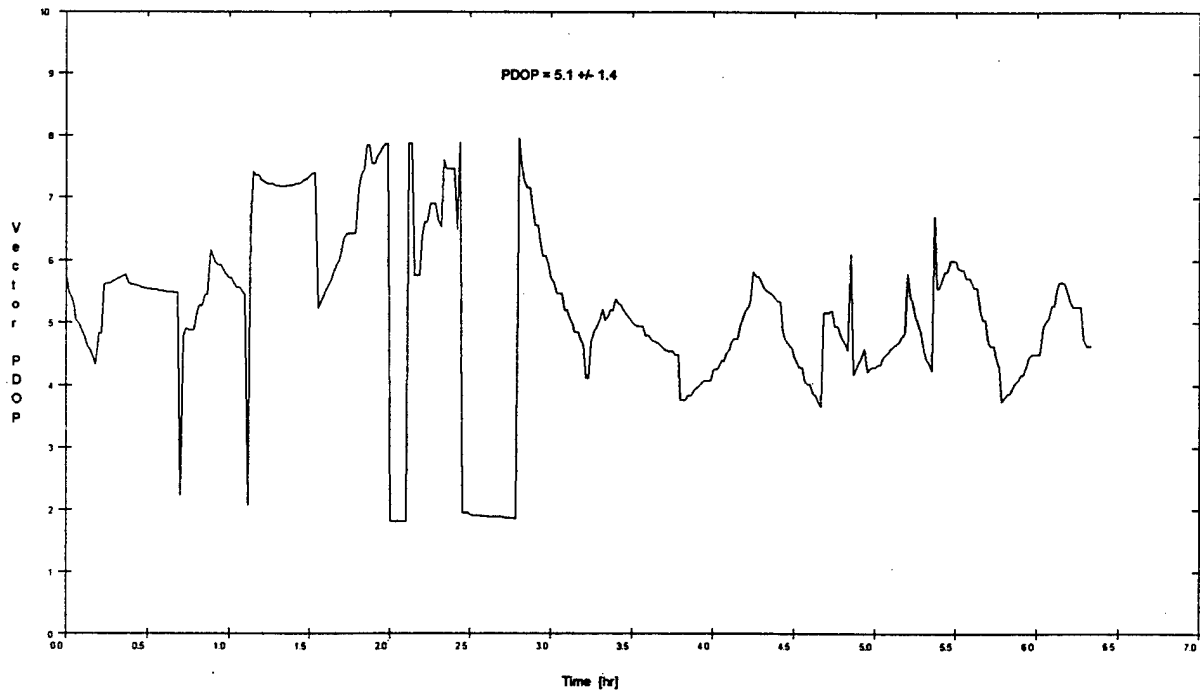

**Figure 33: PDOP as determined by Trimble Vector based on actual Satellites**

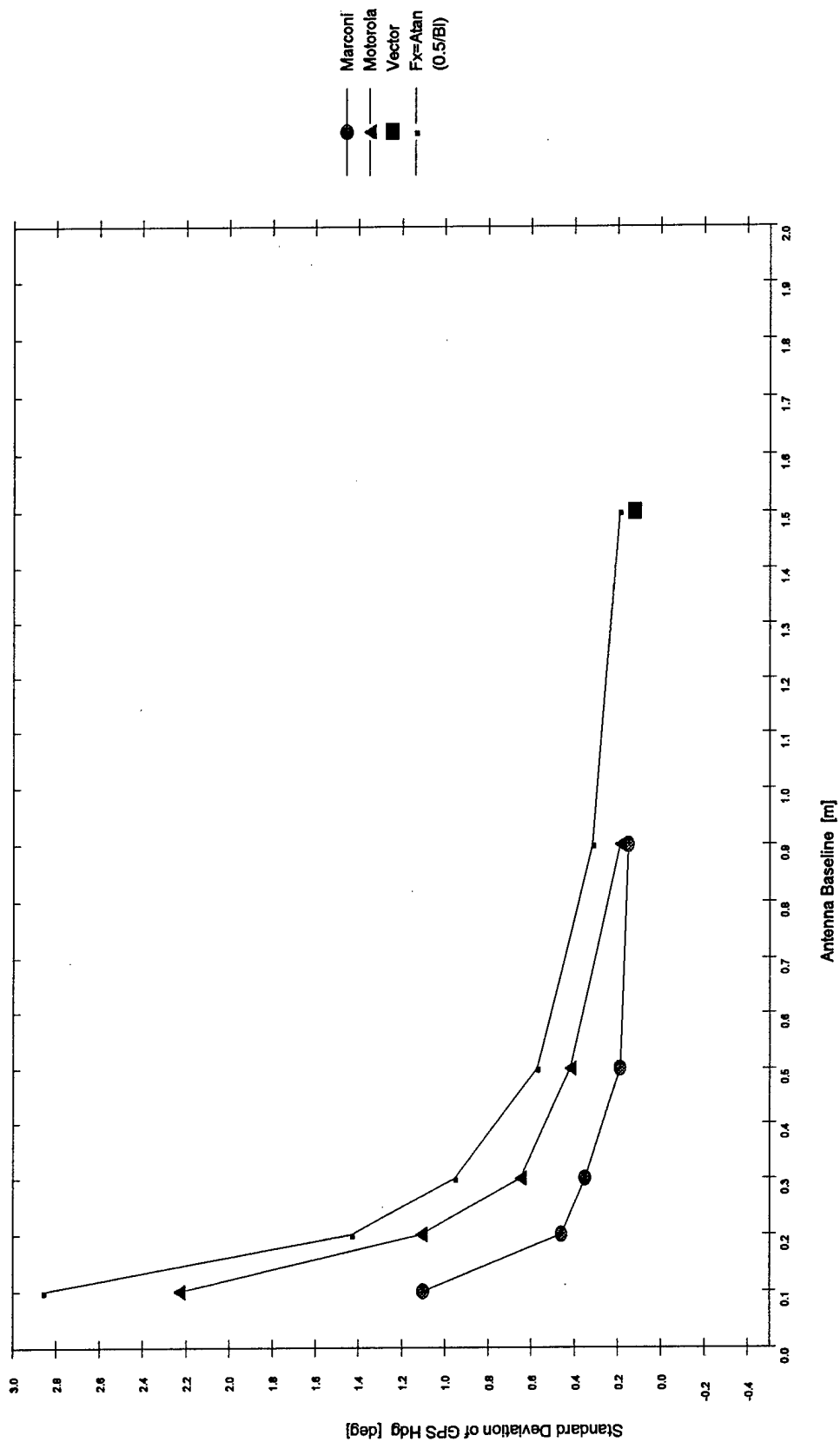

Figure 34: Standard Deviation of Heading as Function of Baseline Length

File	Time to Resolution [sec]	Availability [%]	Heading	
			East [deg]	South [deg]
CMC 10 cm, <30deg	2.1±5.7	90.8±11.4	83.6±1.8	173.0±1.0
CMC 20 cm, <30deg	21.0±66.7	89.2±19.9	83.8±2.0	173.6±1.4
Summary	-	90.0±15.9	83.7±1.9	173.3±1.2
VP 10 cm, <30deg	1.2±3.0	94.0±9.1	87.3±2.2	177.5±1.4
VP 20 cm, <30deg	13.4±44.3	85.6±20.5	88.4±2.1	177.1±0.9
Summary	-	90.0±16.0	87.8±2.2	177.3±1.2

Table 3 GPS Receiver Heading Data Summary

(as a deviation from the 'mean' value over the test period) for these tests and the results are shown in Figures 35, 36 and 37. Figure 35 is a plot of the Trimble TANS Vector deviation (error) in position over a 16-hour period. The error is 31.2m over this time period; quite good performance. The error in the Marconi CMT 8700 is plotted in Figure 36 and has an error of over 900m(!) although this large error is due to only a few very large errors over the time period (the graph has been scaled and does not show the very large errors that appear in the data). Nonetheless, the receiver provided these data points as valid positions over the course of the test period. This is quite surprising and no reason for this result has yet been determined. Similarly, Figure 37 is a plot of the Motorola VP Oncore position error data and shows an error of 21.07m which is quite reasonable GPS performance. These results will be further investigated.

### 3.4 Discussion

A brief discussion of some of the above test results would seem appropriate at this point. There are some obvious questions and apparent limitations arising as a result of the data analysis. Four areas in particular require some explanation; noise level, dropouts, TTFF/TTR and multistable results.

Firstly, the noise level seen in the heading results, although consistent with expected values, shows some apparent 'drift' during some tests as well as sudden changes in level in other tests. This latter result appears to be due to HEAD incorrectly determining the integer wavelength between antennas and to changes in satellite geometry; the dropping of a satellite followed by the acquisition of another to replace it. This is unpredictable and is receiver-dependent. The small 'drift' seen during some tests most likely is caused by multipath effects and is quite small, usually less than one degree over the length of a test data set.

Dropouts, as discussed, are more prevalent at larger (>30 deg) pitch and roll angles although several very long dropouts occurred with no antenna baseline pitch or roll. These results are somewhat disturbing since no apparent explanation exists at this time. Review of the raw data files indicates that raw phase data was available from both receiver sets during these dropout events and that both receivers were functioning normally. This would indicate that the problem lies in the HEAD processing and this possibility has been discussed with the University of Calgary. They have been provided with the raw data and are investigating the phenomenon.

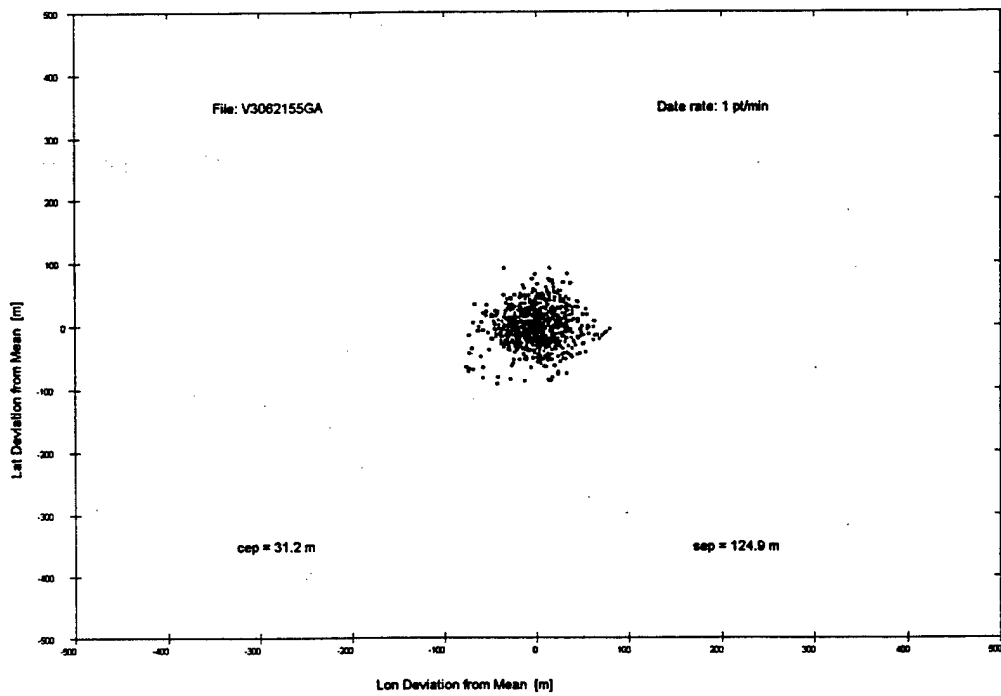

**Figure 35: Trimble TANS Vector Position Deviation from Mean**

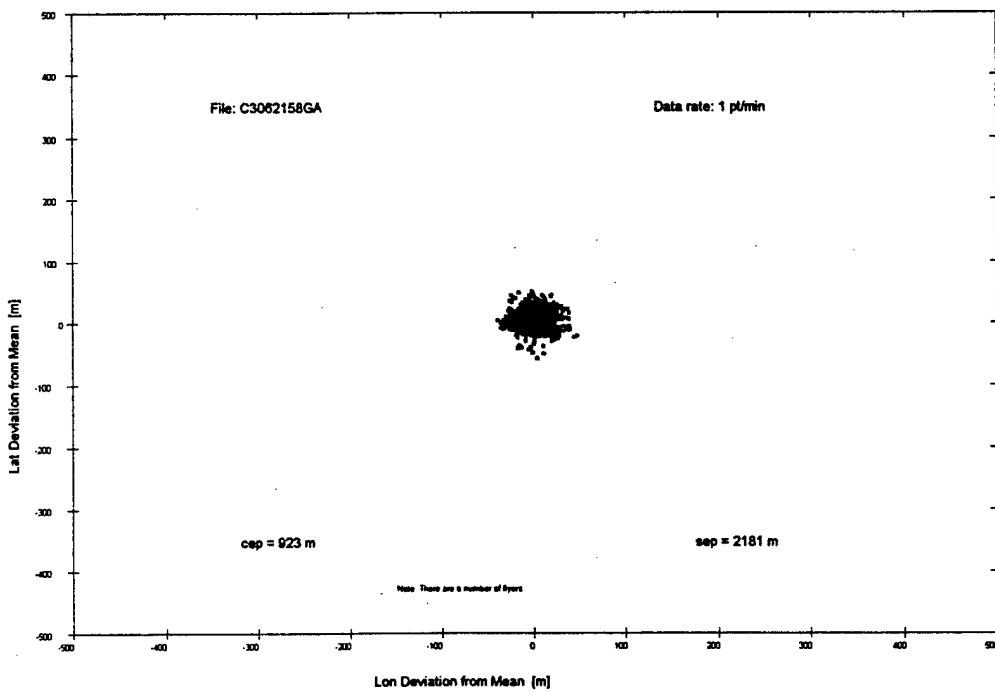

**Figure 36: Marconi CMT-8700 Position Deviation from Mean**

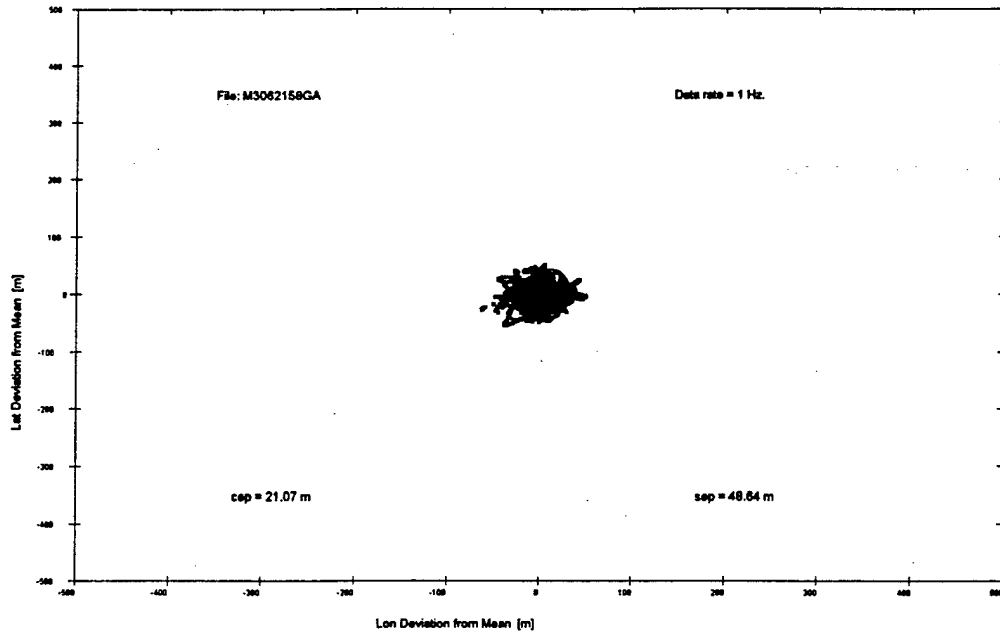

**Figure 37: Motorola VP Oncore Position Deviation from Mean**

The question of Time-To-First-Fix and Time-To-Resolution has several important impacts on practical applications of this system. TTR is a function of HEAD's ability to resolve phase ambiguities and provide a heading output as quickly as possible. This ability is the focal point of all development in attitude determination using GPS and continues to be an area of ongoing research. The effect of TTR is outside the control of users such as ourselves; it is a receiver/manufacture-specific term but one which impacts end-users in a fundamental way. The crux of the problem lies in the requirement for a GPS receiver to obtain a valid almanac of satellites before being capable of providing useful data to a user. If a receiver does not already have within its non-volatile memory a copy of a valid almanac (a valid almanac is usually defined as being one less than 60 days old), it must acquire one from an orbiting satellite before it can provide a position solution to the user. This process requires a minimum of 12 minutes after acquisition of a satellite by the receiver from a cold start. All receivers obtain and store almanac data on a regular basis during operation and if a receiver is used regularly (more often than every 60 days), the almanac remains current and TTR reduces to the order of one or two minutes (less than this in some receiver designs). Alternately, a user can 'load' a valid almanac into a receiver from another receiver or a PC if desired but this requires a physical connection between the receivers. This requirement becomes significant if a receiver is to be held in storage for some long (>60 days) period of time before activation. If a valid almanac is not loaded into the receiver, a delay of at least 12 minutes must be accepted by the user before the GPS data is available for use. In the sonobuoy application, this becomes significant from an operator's viewpoint; 12 minutes is a long time to wait. This problem is being addressed to see if some method of loading an almanac into the sonobuoy receivers is feasible. In other applications, this may not be as significant.

The last item of discussion concerns the multistable output as defined previously. This is also a disturbing problem since, as discussed, there is no way to determine whether the heading provided by HEAD is correct at any point in time without some external reference. This has also been discussed with the University of Calgary and they are reviewing the data.

In addition to the above limitations, several other points of interest should be mentioned. In particular, it should be noted that all tests discussed here were static in nature and involved no attempt to undergo any dynamics. The use of this system on a moving vehicle is the subject of the next series of tests to be undertaken. The HEAD software is

in the process of being modified to operate in real time; testing under dynamic conditions will be carried out using that software. The dynamic envelope within which the heading determination system can function will be determined for use in other potential military applications.

## 4.0 CONCLUSIONS AND RECOMMENDATIONS

### 4.1 Conclusions

The results of the trials carried out on the two GPS receiver sets indicate that GPS is a viable method of heading determination in the Arctic environment for a body such as the ice-pick sonobuoy. Heading can reliably be determined to better than 5 degrees under most conditions of short baseline length down to 10 cm and for pitch and roll angles of up to 30 degrees. Satellite geometry appears to have no significant detrimental impact on GPS performance in the Arctic; in fact, the availability of an increased number of satellites at high latitudes may be an advantage in providing increased measurement redundancy.

The use of commercial, off-the-shelf receivers implies that cost savings can be achieved in an operational system since no new technologies need be developed specifically for this application. Both receiver types performed adequately under the conditions described above although a significant performance difference was apparent. This implies that any receiver selected for this application should be carefully specified and other manufacturer's equipment should be thoroughly evaluated prior to procurement. The % availability could most likely be improved through continued enhancements of the HEAD processing software. This software performed very well with both receiver types and has also been used, by the University of Calgary, with other receivers with good results. Dropouts and multistable output effects are also areas for further investigation and data has been provided to U of C for evaluation and discussion.

If GPS is to be considered for the ice-pick sonobuoy application, a realistic 'envelope' within which performance can be optimized should include an antenna separation of 10 cm (or, with further investigation, perhaps even less) and a 'useable' impact angle of less than 30 degrees in pitch and roll. Data on the actual angles at which a sonobuoy impacts and remains in the ice has not been reviewed by DREO at this point.

Although the work described in this report was focused on the evaluation of GPS for use in the Arctic sonobuoy, the results can be extended to numerous other potential military applications, particularly those which may require a restricted separation (less than 1 metre) between antennas.

## 4.2 Recommendations

The following recommendations are made as a result of the investigation of GPS as a method of heading determination for an Arctic sonobuoy:

1. Due to the decrease in heading performance at larger pitch and roll angles, further investigation should be conducted to determine a realistic and acceptable envelope within which an ice-pick sonobuoy is expected to provide useful and valid heading data. This can be determined from a review of operational performance of these sensors as well as further development of the processing algorithm to investigate possible performance enhancements for the GPS attitude determination capability under more severe conditions.

2. A specification document for GPS receiver performance should be developed for use in comparing manufacturer's equipment. This document could also contain configuration (size, weight, power) requirements for both the receivers and the antennas.

3. The use of other receiver types should be considered including the use of encrypted P-code, dual frequency and differential GPS. Although these may not be pertinent to this application at this time, they have not, to this point, been considered and may have future application.

4. The HEAD processing software package should be further developed in several areas. Further investigation into dropouts, time-to-resolution and multistable performance should be conducted to optimize performance. As well, the software should be reconfigured to operate in real time. This step has already been undertaken by U of C under contract to DREO. A real-time version of HEAD will be delivered to DREO in March of 1997 for evaluation. DREO has undertaken this work since it also has relevance to several other DND operational applications under study and will also be used to evaluate dynamic performance capabilities.

5. The mechanical and electronic implications of adding GPS to an operational sonobuoy have not been directly addressed as part of this study. Such items as the physical integration of the GPS receivers, the placement of antennas, the initialization of the receivers and the method of providing the phase data and processing it must be considered before initiating any further work. This will require the input of operational personnel as well as both sonobuoy and GPS manufacturers. This work should be coordinated with DREA which has extensive experience with

sonobuoy development as well as with EDRD which is performing complementary work in the Arctic sonobuoy field.

DREO will continue to explore many of these areas as part of our continuing work with GPS.

## 5.0 REFERENCES

1. "Precision Orientation: A New GPS Application" Joseph, K.M. and Deem, P.S., International Telemetry Conference, San Diego, CA, Oct., 1983.
2. "Using GPS to Determine Vehicle Attitude: USS Yorktown Results" Kruczynski, L.R., Li, P.C., Evans, A.G., and Hermann, B.R., Proceedings of ION GPS-89, Institute of Navigation, Washington, DC, Sept., 1989.
3. "Flight Tests of Attitude Determination Using GPS Compared Against an Inertial Navigation Unit" Cohen, C.E., McNally, B.D., and Parkinson, B.W., Navigation, Vol 41, No 1, 1994.
4. "Global Positioning System: Theory and Applications Volume II" Parkinson and Spilker, Eds., American Institute of Aeronautics and Astronautics, Inc, 1996.
5. "ADU2 GPS Attitude Determination Unit", Ashtech Technical Brochure, Aug., 1996.
6. "TANS Vector GPS Receiver for Attitude Determination", Trimble Technical Brochure, 1996.
7. "TRIADS, The ASI Attitude Determining System", Adroit Systems Inc. Technical Brochure, 1993.
8. "Interferometric GPS Attitude: A Stochastic Error Model", McMillan, J. Chris, DREO Report #1168, Feb. 1993.
9. "Assessment of a Non-Dedicated GPS Receiver System for Precise Airborne Attitude Determination" Cannon, M.E., Sun, H., Owen, T.E. and Meindl, M.A., GPS-94, The Institute of Navigation, Salt Lake City, Sept., 1994.
10. "Precision Shipborne Attitude Determination Using Wide Antenna Spacing" Lachapelle, G., Lu, G. and Loncarevic, B., Proceedings of International Symposium on Kinetic Systems in Geodesy, Geomatics and Navigation- KIS94, Dept of Geomatics Eng., University of Calgary, 1994.
11. "Dynamic GPS Attitude Performance Using GPS/INS Reference" McMillan, J.C., Arden, D.A.G., Lachapelle, G. and Lu, G., Canadian Aeronautics and Space Journal, Can. Aeronautics and Space Institute, Ottawa, Vol 41, No 1, 1995.

12. "TANS Vector Four-Antenna GPS Attitude Determination System Specification and User Manual", Trimble, Inc. Part No 20997, Rev A, 1993.
13. "Development of a Low Cost GPS Attitude Determination System" Lachapelle, G. and Cannon, M.E., Contract Report No W7714-5-9942/010/SV, May, 1996, pg.2.
14. "Shipborne Attitude Determination Using Multi-Antenna GPS Technologies" Lu, G. Cannon, M.E., Lachapelle, G. and Kielland, P., IEEE Transactions on Aerospace and Electronic Systems, Correspondence, 30, 4, Oct. 1994.
15. "Performance Analysis of a Shipborne Gyrocompass with a Multi-Antenna GPS System" Lu, G., Lachapelle, G., Cannon, M.E. and Vogel, B., Proceedings of PLANS'94, IEEE, New York, 1994.
16. "HEAD Operator's Manual" Sun, H. and Cannon, M.E., University of Calgary, Dept of Geomatics Eng., Aug., 1995.
17. Ashtech Mission Planning Software Package, Ashtech, Inc. 1990-1993.

## DOCUMENT CONTROL DATA

(Security classification of title, body of abstract and indexing annotation must be entered when the overall document is classified)

1. ORIGINATOR (the name and address of the organization preparing the document. Organizations for whom the document was prepared, e.g. Establishment sponsoring a contractor's report, or tasking agency, are entered in section 8.) Defence Research Establishment Ottawa 3701 Carling Ave., Ottawa, Ontario K1A 0Z4		2. SECURITY CLASSIFICATION (overall security classification of the document including special warning terms if applicable) UNCLASSIFIED	
3. TITLE (the complete document title as indicated on the title page. Its classification should be indicated by the appropriate abbreviation (S,C or U) in parentheses after the title.) GPS HEADING DETERMINATION USING SHORT ANTENNA BASELINES (U)			
4. AUTHORS (Last name, first name, middle initial) Vinnins, Michael and Gallop, Lloyd D.			
5. DATE OF PUBLICATION (month and year of publication of document) April 1997	6a. NO. OF PAGES (total containing information. Include Annexes, Appendices, etc.) 53	6b. NO. OF REFS (total cited in document) 17	
7. DESCRIPTIVE NOTES (the category of the document, e.g. technical report, technical note or memorandum. If appropriate, enter the type of report, e.g. interim, progress, summary, annual or final. Give the inclusive dates when a specific reporting period is covered.) DREO TECHNICAL NOTE			
8. SPONSORING ACTIVITY (the name of the department project office or laboratory sponsoring the research and development. Include the address.) DAEPM (M)			
9a. PROJECT OR GRANT NO. (if appropriate, the applicable research and development project or grant number under which the document was written. Please specify whether project or grant) 3DG13		9b. CONTRACT NO. (if appropriate, the applicable number under which the document was written)	
10a. ORIGINATOR'S DOCUMENT NUMBER (the official document number by which the document is identified by the originating activity. This number must be unique to this document.) DREO TECHNICAL NOTE: 98-001		10b. OTHER DOCUMENT NOS. (Any other numbers which may be assigned this document either by the originator or by the sponsor)	
11. DOCUMENT AVAILABILITY (any limitations on further dissemination of the document, other than those imposed by security classification) <input checked="" type="checkbox"/> Unlimited distribution <input type="checkbox"/> Distribution limited to defence departments and defence contractors; further distribution only as approved <input type="checkbox"/> Distribution limited to defence departments and Canadian defence contractors; further distribution only as approved <input type="checkbox"/> Distribution limited to government departments and agencies; further distribution only as approved <input type="checkbox"/> Distribution limited to defence departments; further distribution only as approved <input type="checkbox"/> Other (please specify):			
12. DOCUMENT ANNOUNCEMENT (any limitation to the bibliographic announcement of this document. This will normally correspond to the Document Availability (11). However, where further distribution (beyond the audience specified in 11) is possible, a wider announcement audience may be selected.) UNLIMITED			

13. **ABSTRACT** ( a brief and factual summary of the document. It may also appear elsewhere in the body of the document itself. It is highly desirable that the abstract of classified documents be unclassified. Each paragraph of the abstract shall begin with an indication of the security classification of the information in the paragraph (unless the document itself is unclassified) represented as (S), (C), or (U). It is not necessary to include here abstracts in both official languages unless the text is bilingual).

Defence Research Establishment Ottawa has completed an exploratory investigation into the use of GPS as a method of heading determination for an in-ice Arctic surveillance sensor, known as an ice-pick sonobuoy, dropped from a surveillance aircraft into the ice cover of the Canadian high Arctic.

The parameters within which the system was to function included operation above a latitude of 80 degrees north with a bearing accuracy of better than 5 degrees. Due to the small diameter of the sonobuoy, the investigation was to centre on the use of extremely short antenna baseline separations; 10 cm, if achievable, as well as the use of inexpensive, off-the-shelf receivers of small size and low power consumption.

The Department of Geomatics Engineering at the University of Calgary has developed a software package called 'HEAD' which was designed to accept phase data inputs from a pair of GPS receivers, each with their own antenna and provide heading and pitch information to the user in a non real-time environment. DREO licenced this system from U of C for the sonobuoy investigations.

Two receiver sets were evaluated; the Canadian Marconi CMT 8700 and the Motorola VP Oncore. Trials were performed at CFS Alert in the Canadian Arctic under various ice/snow and satellite geometry conditions and several baseline separations.

Test results indicated that GPS was a viable option for use in the ice-pick sonobuoy application providing heading accuracies of better than 5 degrees under almost all test conditions. This technology is also expected to be applicable to numerous other applications including land vehicle heading determination, artillery surveying, antenna pointing and targeting applications.

The system is now undergoing conversion to real-time operation for further evaluation in 1997.

14. **KEYWORDS, DESCRIPTORS or IDENTIFIERS** (technically meaningful terms or short phrases that characterize a document and could be helpful in cataloguing the document. They should be selected so that no security classification is required. Identifiers, such as equipment model designation, trade name, military project code name, geographic location may also be included. If possible keywords should be selected from a published thesaurus. e.g. Thesaurus of Engineering and Scientific Terms (TEST) and that thesaurus-identified. If it is not possible to select indexing terms which are Unclassified, the classification of each should be indicated as with the title.)

GPS  
Attitude Determination System  
Navigation  
Heading  
Bearing  
Interferometry