

# NAVAL POSTGRADUATE SCHOOL MONTEREY, CALIFORNIA



## THESIS

THIS QUALITY INSPECTED 4

**IMPROVING AVIATION DEPOT LEVEL  
REPAIRABLE (AVDLR) INVENTORY AND  
REPAIR MANAGEMENT**

by

Dennis L. Baird

December, 1997

Thesis Advisor:

Thomas P. Moore

Approved for public release; distribution is unlimited.

19980427 160

# REPORT DOCUMENTATION PAGE

Form Approved OMB No. 0704-0188

Public reporting burden for this collection of information is estimated to average 1 hour per response, including the time for reviewing instruction, searching existing data sources, gathering and maintaining the data needed, and completing and reviewing the collection of information. Send comments regarding this burden estimate or any other aspect of this collection of information, including suggestions for reducing this burden, to Washington Headquarters Services, Directorate for Information Operations and Reports, 1215 Jefferson Davis Highway, Suite 1204, Arlington, VA 22202-4302, and to the Office of Management and Budget, Paperwork Reduction Project (0704-0188) Washington DC 20503.

1. AGENCY USE ONLY <i>(Leave blank)</i>		2. REPORT DATE December 1997	3. REPORT TYPE AND DATES COVERED Master's Thesis	
4. TITLE AND SUBTITLE Improving Aviation Depot Level Repairable (AVDLR) Inventory and Repair Management			5. FUNDING NUMBERS	
6. AUTHOR(S) Dennis L. Baird				
7. PERFORMING ORGANIZATION NAME(S) AND ADDRESS(ES) Naval Postgraduate School Monterey CA 93943-5000			8. PERFORMING ORGANIZATION REPORT NUMBER	
9. SPONSORING/MONITORING AGENCY NAME(S) AND ADDRESS(ES)			10. SPONSORING/MONITORING AGENCY REPORT NUMBER	
11. SUPPLEMENTARY NOTES The views expressed in this thesis are those of the author and do not reflect the official policy or position of the Department of Defense or the U.S. Government.				
12a. DISTRIBUTION/AVAILABILITY STATEMENT Approved for public release; distribution is unlimited.			12b. DISTRIBUTION CODE	
13. ABSTRACT <i>(maximum 200 words)</i> The processes by which the Navy manages the inventory and repair of Aviation Depot Level Repairables (AVDLRs) are complex and not well described in a single document. The purpose of this thesis is to document and provide an analysis of those processes as a basis for future research. Research was conducted on the process of returning not ready for issue (NRFI) units from the end user to the depot for repair and return to the supply system. Additionally, research was conducted to document the management process for determining repair requirements at the Naval Inventory Control Point Philadelphia and how those requirements are accepted and scheduled at NADEP North Island. These processes were described and analyzed, and six areas were identified that offer potential for reducing repair cycle time and improving AVDLR management.				
14. SUBJECT TERMS Aviation Depot Level Repairable (AVDLR) Inventory and Repair Management			15. NUMBER OF PAGES 132	
			16. PRICE CODE	
17. SECURITY CLASSIFICATION OF REPORT Unclassified	18. SECURITY CLASSIFICATION OF THIS PAGE Unclassified	19. SECURITY CLASSIFICATION OF ABSTRACT Unclassified	20. LIMITATION OF ABSTRACT UL	

NSN 7540-01-280-5500

Standard Form 298 (Rev. 2-89)  
Prescribed by ANSI Std. Z39-18 298-102



Approved for public release; distribution is unlimited.

**IMPROVING AVIATION DEPOT LEVEL REPAIRABLE (AVDLR)  
INVENTORY AND REPAIR MANAGEMENT**

Dennis L. Baird  
Lieutenant Commander, Supply Corps, United States Navy  
B.S., University of the State of New York, 1986

Submitted in partial fulfillment  
of the requirements for the degree of

**MASTER OF SCIENCE IN MANAGEMENT**

from the

**NAVAL POSTGRADUATE SCHOOL**

**December 1997**

Author:

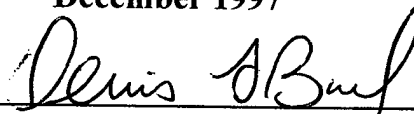

Dennis L. Baird

Approved by:

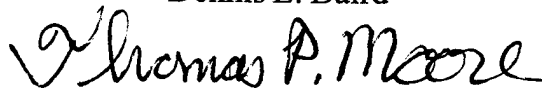

Thomas P. Moore, Thesis Advisor



Kevin R. Gue, Associate Advisor

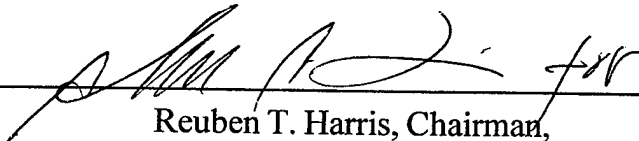

Reuben T. Harris, Chairman,  
Department of Systems Management



## ABSTRACT

The processes by which the Navy manages the inventory and repair of Aviation Depot Level Repairables (AVDLRs) are complex and not well described in a single document. The purpose of this thesis is to document and provide an analysis of those processes as a basis for future research.

Research was conducted on the process of returning not ready for issue (NRFI) units from the end user to the depot for repair and return to the supply system. Additionally, research was conducted to document the management process for determining repair requirements at the Naval Inventory Control Point Philadelphia and how those requirements are accepted and scheduled at NADEP North Island. These processes were described and analyzed, and six areas were identified that offer potential for reducing repair cycle time and improving AVDLR management.



## TABLE OF CONTENTS

I.	INTRODUCTION.....	1
A.	INTRODUCTION.....	2
B.	BACKGROUND.....	2
C.	PURPOSE.....	3
D.	SCOPE AND LIMITATIONS.....	4
E.	METHODOLOGY.....	5
F.	ORGANIZATION.....	5
II.	OVERVIEW OF AVIATION DEPOT LEVEL REPAIRABLES.....	9
A.	DESCRIPTION OF REPAIRABLES.....	9
B.	DEFENSE BUSINESS OPERATIONS FUND (DBOF).....	13
C.	APPROPRIATIONS PURCHASES ACCOUNT (APA).....	14
D.	DLR CARCASS TURN-IN.....	14
E.	MASTER REPAIRABLE ITEM LIST (MRIL).....	16
F.	ADVANCED TRACEABILITY AND CONTROL (ATAC).....	19
III.	MANAGEMENT OF AVIATION DEPOT LEVEL REPAIRABLES.....	21
A.	INTRODUCTION.....	21
B.	AVDLR REPAIR PROCESS OVERVIEW.....	21
IV.	MANAGEMENT OF AVIATIONS DEPOT LEVEL REPAIRABLES.....	39
A.	INTRODUCTION.....	39
B.	PROGRAM SUPPORT INVENTORY CONTROL POINT CONCEPT.....	40
C.	REPAIRABLES MANAGEMENT FUNCTIONS.....	41
D.	ORGANIC REPAIR MANAGEMENT PROGRAMS.....	43
E.	UICP OVERVIEW.....	47
F.	UICP FILES.....	50
G.	UICP PROGRAMS (SOFTWARE APPLICATIONS).....	51
H.	CYCLICAL LEVELS FORECASTING STRING.....	58

I.	C-LIST AT WORK.....	59
J.	SCHEDULED ORGANIC REPAIR EXECUTION PROCESS.....	59
K.	SCHEDULED B08 REPAIR.....	65
L.	UNSCHEDULED B08 REPAIR.....	66
M.	PROCESS AT NADEP NI FOR SCHEDULED REPAIR NEGOTIATION.....	66
N.	SUMMARY.....	69
V.	ANALYSIS OF REPAIR CYCLE PROCESSES.....	71
A.	INTRODUCTION.....	71
B.	SCHEDULED REQUIREMENTS AND COMPUTED REQUIREMENTS.....	71
C.	MEASUREMENT OF RETROGRADE SEGMENT OF THE REPAIR CYCLE.....	78
D.	INBOUND NRFI TOTAL ASSET VISIBILITY.....	84
E.	NADEP PROCESSES.....	88
F.	PIECE PARTS AVAILABILITY.....	91
G.	AUTOMATION OF CRC SCHEDULING.....	93
H.	COSTS OF COMMERCIAL VS ORGANIC VS DMISA REPAIR...	94
VI.	RECOMMENDATIONS, CONCLUSIONS, AND FURTHER STUDY.....	97
A.	INTRODUCTION.....	97
B.	CONCLUSIONS.....	97
C.	RECOMMENDATIONS.....	100
D.	FURTHER STUDY.....	104
APPENDIX A.	GLOSSARY OF ACRONYMS AND ABBREVIATIONS.....	105
APPENDIX B.	INTENSIVE REPAIRABLE ITEM MANAGEMENT (IRIM).....	111
APPENDIX C.	DD FORM 1348-1 Blocks for DLR Turn-in.....	115
LIST OF REFERENCES.....		117

INITIAL DISTRIBUTION LIST.....121

## I. INTRODUCTION

### A. INTRODUCTION

In this thesis we carefully document the processes by which the Naval Inventory Control Point Philadelphia (NAVICP-P) manages the repair of Aviation Depot Level Repairables (AVDLRs) at Naval Aviation Depot North Island (NADEP NI). Those processes are complex and often undocumented. Many of the instructions dealing with AVDLRs are a decade or more old. The intention of this research is to serve as a springboard for future research in simulation and modeling of the repair management processes and material flows.

To serve that purpose flowcharts are constructed for a number of processes of the repair cycle. We begin by developing a model of the DLR process. We then we constructed a flowchart of the flow of a carcass from the end user to the Designated Support Point, to NADEP NI, and back to the supply system as ready-for-issue (RFI). Next we constructed a flowchart of the process of induction and repair at NADEP NI in more detail. We then constructed

flowcharts of the management processes by which organic repair requirements are determined, scheduled, and executed.

## **B. BACKGROUND**

NAVICP-P currently manages approximately 69,000 AVDLR line items. The annual repair budget is \$1.1 billion and the procurement budget is \$650 million. Repairs are made by three types of depots: organic depots (NADEPs), commercial depots, and other services' depots under Defense Inter-service Maintenance Agreements (DMISA). Table 1 shows the quantities, dollar values, and number of line items repaired by each of the three types of depots. (Hill, 1997). An analysis of the costs for each of the items in Table 1 is discussed in Chapter V.

The depot repair cycle (DRC) for AVDLRs begins with the determination that an unserviceable or not-ready-for-issue (NRFI) item is beyond the repair capability of the intermediate-level maintenance facility. This determination is made by an Aviation Intermediate Maintenance Department (AIMD).

The cycle ends when the item is repaired to a serviceable condition and is recorded as ready-for-issue (RFI). The intermediate repair level determination of beyond-the-capability-of-maintenance (BCM) for AVDLRs is made at the intermediate level.

This thesis focuses primarily on the processes by which

Type of Repair Depot	Annual Repair Costs (million \$)	Units Repaired	Cost to Unit Ratio
Organic (NADEP)	600	112,000	5,357
Commercial	400	47,000	8,511
DMISA	100	25,000	4,000
Total	1,100	184,000	5,978

	Number of Line Items Repaired
Organic (NADEP)	43,000
Commercial	10,500
DMISA	10,000
Dual	3,000
Inactive (no depot assigned)	2,500
Total	70,000

Table 1. Annual Component Repairs (Hill, 1997)

the NAVICP-P determines the requirements for inducting carcasses into the NADEP, the process for induction, and the process by which an item returns RFI to the supply system.

### C. PURPOSE

The purpose of this thesis is to carefully document and analyze the processes involved in the inventory and repair

management of AVDLRs. In this study we consider the following questions:

- What are the processes involved in the AVDLR repair cycle?
- How can these processes be improved to reduce repair cycle time?
- What redundancies and inefficiencies exist in the repair cycle?
- How can we reduce the AVDLR inventory levels required to support demand during repair cycle time?

#### **D. SCOPE AND LIMITATIONS**

The examination of active repair is limited to NADEP NI because of travel and time constraints experienced by this researcher. For similar reasons, the research into the requirements determination process is limited to NAVICP-P. We recognize that there are many other activities which play a major role in the planning of AVDLR repairs either through policy and program development or funding authorization. Those activities include the Naval Air Systems Command, type commanders, and Naval Supply Systems Command.

Each specific AVDLR can move through a different set of active repair steps. The steps that lead to induction and

the steps in returning the RFI item to the supply system after repair has been completed are common for most AVDLRS. In this thesis we have followed an alternating motor for the pitch trim hydraulic actuator on an S-3 aircraft through the material flow process.

#### **E. METHODOLOGY**

To answer the research questions we begin first by documenting the actual processes of repairables management. This was accomplished by collecting information from personal interviews, current Navy instructions and publications, and automated systems outputs provided by the activities we visited. Personal interviews were conducted at NAVICP-P, NADEP NI, Fleet Industrial Supply Center (FISC) San Diego, and Defense Distribution Depot California (DDDC) San Diego.

#### **F. ORGANIZATION**

Chapter II, Overview Of Aviation Depot Level Repairable (AVDLRs), provides a brief overview of depot level repairables (DLRs) and more specifically AVDLRs. Emphasis is placed on organic repairs made by a NADEP and the repair requirements determination process.

Chapter III, Aviation Depot Level Repairable Organic Repair Cycles, describes the processes involved in repairing AVDLRs at organic facilities. The processes are documented from failure at the end user's activity through to repair of the failed item and return to the supply system.

Chapter IV, Repairables Management Processes, provides documentation of the processes involved in managing repairables at NAVICP-P. Emphasis is placed on repair requirements determination and the process by which repair requirements are scheduled for induction at NADEP NI.

Chapter V, Analysis of Repair Cycle Processes, provides an analysis of the data collected throughout the repair cycle and compares that data to assumptions made during requirements determination computation.

Chapter VI, Recommendations, Conclusions, and Further Study, summarizes key aspects of the study, provides recommendations, presents conclusions, and provides suggestions for further study.

APPENDIX A, Glossary of Acronyms and Abbreviations provides a list of acronyms and abbreviations used in this thesis.

Appendix B, Intensive Repairable Item Management (IRIM) describes the IRIM program.

Appendix C, DD FORM 1348-1 Blocks for DLR Turn-in provides brief explanations of the information required in the blocks of the DD Form 1348-1 for DLR turn-ins.



## II. OVERVIEW OF AVIATION DEPOT LEVEL REPAIRABLES (AVDLRS)

### A. DESCRIPTION OF REPAIRABLES

Repairables are components or subassemblies which can be replaced to make an unserviceable end item function properly. Repairables are usually high cost, long procurement lead time items. Because of these characteristics, significant economies of scale can be achieved by repairing these items rather than discarding them when they become unserviceable. Figure 1 illustrates the depot level repair process. (NAVSUP P-545, 1989)

DLRs are repairables for which the condemnation decision should be made at the depot repair level.<sup>1</sup> Unserviceable DLRs may be repairable at the organizational, intermediate, or depot level. This determination is normally made at the time of provisioning for the weapon system. An appropriate Source, Maintenance and Recoverability (SM&R) Code is assigned to each item

---

<sup>1</sup> Some DLRs are repaired at the organization level. For example under the 2M repair program for micro/miniature electronics repairs are first attempted at the organization level then the intermediate level and then the depot level. (NAVSUP P-485 par 3263, 1996)

indicating the level and degree of maintenance authorized. The SM&R codes are explained in the Introduction to the COSAL and in the COSAL Use and Maintenance Manual (SPCCINST 4441.170 Series). Based on the SM&R Code assignments, DLRs

### REPAIRABLES PIPELINE

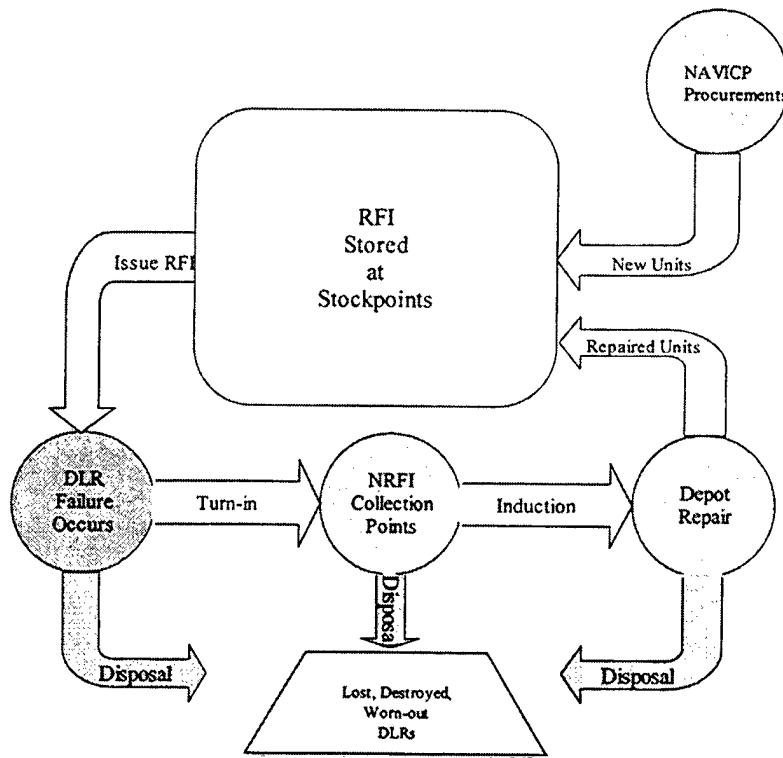

Figure 1. Repairables Pipeline

are subsequently identified in various publications by Material Control Codes (MCCs) E, G, H, Q and X which indicate that the items are DLRs.

DLRs must be turned in through the supply system after they fail, or are determined to be in Not Ready For Issue (NRFI) condition. The supply system has the item moved to the Designated Overhaul Point (DOP) or Designated Support Point (DSP). DLRs are further categorized as Aviation Depot Level Repairables (AVDLRs), Non-Aviation DLRs (Non-AVDLRs), DBOF owned DLRs, Appropriation Purchases Account (APA) DLRs and End-Use DLRs.

AVDLRs are DLRs under the management of the Naval Inventory Control Point Philadelphia (NAVICP-P) for which selected repair/maintenance can be accomplished at the intermediate level. AVDLRs which are determined to be Beyond Capability of Maintenance (BCM) at the Intermediate Maintenance Activity (IMA) must be shipped in accordance with the Master Repairable Item List (MRIL) to a depot repair facility for complete repair, restoration or condemnation. AVDLRs may be counted as an asset in the DBOF (which is also called the Navy Stock Account (NSA)), End-Use Stores Account or the Appropriation Purchases Account (APA).

Non-Aviation Depot Level Repairables (Non-AVDLRs) are under the management of the Naval Inventory Control Point

Mechanicsburg (NAVICP-M). Like AVDLRs, unserviceable Non-AVDLRs are to be shipped to a depot repair facility for subsequent repair when they cannot be repaired at the IMA and/or organizational level. Non-AVDLRs may also be carried in the DBOF, End-Use or APA fund account. This thesis does not examine Non-Aviation DLRs, however, many of the associated processes are identical to those of AVDLRs.

DBOF owned Depot Level Repairables are under the Management of NAVICP-P or NAVICP-M as 7\_ Cog and carried in Navy Stores Account 51000.

APA DLRs are managed by NAVICP-P or NAVICP-M as even numbered Cogs; e.g., 2\_, 4\_, 6\_ and 8\_ Cogs. These DLRs are carried in the Stores Account 52000 and are issued "free" to Navy customers.

End-Use DLRs are customer owned DLRs. End-Use Stores Account 55000 includes 7\_ and 0\_ Cog DLRs carried in W and L Purpose ashore and 7\_ Cog DLRs carried in Special Accounting Class (SAC) AV207 End-Use inventories afloat and at a Marine Aviation Logistics Squadron (MALS). (NAVSUP P-545)

**B. DEFENSE BUSINESS OPERATIONS FUND (DBOF)**

The DBOF (formerly called the Navy Stock Fund) is a revolving fund having two major assets, cash and material. The DBOF cycles cash into material inventory through repair at depots and by purchases from vendors and/or other stock accounts. When the material is received, it is placed in storage where it is held in Navy Stock Account 51000 pending requisitioning by a customer. When the material is issued to a customer, the DBOF is reimbursed by the customer's operating funds. The DBOF cycles cash into inventory through repair and purchases, and inventory back into cash through sales to customers, and the cycle is then repeated.

Inventories of DBOF items are not stocked at the controlling inventory Control Point (ICP). Instead, they are positioned at various stock points as wholesale stocks owned by the ICP. Customer demands are satisfied from these stocks, and replenishments are usually "pushed" to the stock point by the ICP. Normally, DBOF items are carried in Stores Account 51000 and are assigned an "odd" number Cog symbol.

(NAVSUP P-545)

**C. APPROPRIATION PURCHASES ACCOUNT (APA)**

Principal items in the supply system (e.g., aircraft engines, radar systems, computers) are financed by procurement appropriations such as Aircraft Procurement Navy (APN), Weapons Procurement Navy (WPN) or Other Procurement Navy (OPN) appropriations. These items are held in a separate Stores Account 52000 called the Appropriation Purchases Account (APA). Unlike items in the DBOF, which when issued to the customer result in a charge to the user, APA items are issued without charge to the Fleet or other Navy users. They are assigned "even" numbered Cog symbols.

(NAVSUP P-545)

**D. DLR CARCASS TURN-IN**

Turn-in of DLRs, as the result of the Not Ready For Issue (NRFI) exchange, excess turn-ins or inter-IMA transfers, requires strict attention to detail. Many DLRs are expensive and often critical to the mission of the end item. Delays in carcass turn-ins adversely affect readiness by increasing the time before an asset becomes RFI. Loss of an NRFI asset in an NRFI exchange will result in a charge to the user's Operating Target (OPTAR) or Operating Budget.

The amount of the charge is the difference between Net Price and Standard Price (normally referred to as Carcass Value). Losses of carcasses for turn-in prevents the Type Commander or the activity's Operating Budget from receiving credit equivalent to the difference between standard price, and net price, i.e. carcass value. Further, this loss could require the ICP to expend DBOF funds to purchase a new unit.

An exchange NRFI DLR is returned to the supply system along with a DD1348-1 or the bar coded Issue Release Receipt Document (IRRD). In either case the Document Identifier (DOCID) code is BC1 or BC2. Other documents such as a Ship's Maintenance Action Form (2K) or a Visual Information Display System/Maintenance Action Form (VIDS/MAF) will accompany the turn-in. The DD1348-1 cites Management Code E meaning the DLR is being returned as result of an exchange requisition. The document cites the document number of the replacement requisition. The ICP Carcass Tracking Record (CTR) must be able to match the receipt to the expenditure. Turn-ins are made in accordance with instructions found in the Master Repairable Item List (MRIL) and shipped to the closest Advanced Traceability And Control (ATAC) Hub. If the

activity is not under ATAC or the DLR is excluded from the ATAC system the carcass is sent directly to the appropriate Designated Support Point (DSP).

A DSP is the supply activity that provides supply functions for the DOP. The DSP serves as a collection point or holding activity for the DOP. The DOP is the Designated Overhaul Point. The DOP is the depot that is authorized to perform depot level repair for the DLR. (NAVSUP P-545)

**E. MASTER REPAIRABLE ITEM LIST (MRIL)**

All afloat and ashore activities, initial shippers and transhippers handling DLRs use the MRIL to ensure the proper disposition and control of NRFI assets. The MRIL is available on CD ROM and/or mechanized form. These two forms are described below.

The MRIL on CD-ROM is the principal source of repairable data for non-mechanized activities. It is a monthly publication which is compiled by the Navy Fleet Material Support Office (FMSO). The CD-ROM MRIL published and distributed monthly to the afloat forces and shore-based activities. The publication consists of the two parts described below.

## 1. Part I

Part I lists all of the repairables in national item identification number (NIIN) sequence with associated data pertinent to each item; e.g., Account/Cog, Material Control Code, Movement Priority Designator, Shipping Code and Special Notes where applicable.

The shipping code is used to determine the shipping destination of the returned carcass. The Shipping Code may be a six position code or a two position code. A six position code begins with either an alpha N, C or W. The N represents a Navy activity with the remaining five digits being a Unit Identification Code (UIC), the C represents a commercial repair facility and the W represents an Other Service repair facility. C and W Shipping Codes do not contain UICs. If an item appears on the MRIL with more than one Shipping Code, the user selects the DSP/DOP.

Alternatively, a two position Shipping Code is an alpha alpha code (WW, XX, YY or ZZ). Only one alpha alpha Shipping Code may be applicable for a given item. An alpha alpha Shipping Code and a six digit Shipping Code are never assigned to the same item. The WW and YY Shipping Codes

indicate the applicable item is to be sent to disposal. The XX Shipping Code indicates the item is to be shipped to the closest Industrial Naval Air Station (INAS) for NAVICP-P Cog material or the closest FISC for NAVICP-M Cog material. The ZZ Shipping Code indicates disposition/ shipping instructions are to be requested from the ICP.

## **2. Part II**

Part II consists of the shipping addresses for the Shipping Codes appearing in Part I.

## **3. Mechanized MRIL.**

Activities with computer facilities use a computerized version of the MRIL. The data resident in the Mechanized MRIL is, essentially, the same as the data in the CD-ROM or microfiche versions of the MRIL except for the form in which it is established and used.

The Mechanized MRIL is established and maintained on three computer disk files from MRIL tapes provided monthly by FMSO to activities with mechanized capability. One file represents the MRIL data base (equivalent to Part I of the microfiche MRIL); the other two files are identical Shipping Address files (Part II of the microfiche) except one file is

in Shipping Code sequence, while the other is in Activity Sequence Code (ASC) sequence. The ASC is a four position numeric code developed to permit mechanized processing by computing the difference (value) between the processing activity ASC and the listed DSP/DOP ASCs. The lowest value is the closest DSP/DOP, whenever there is more than one DSP/DOP for an item, to which the retrograde material is shipped. (NAVSUP P-545)

**F. ADVANCED TRACEABILITY AND CONTROL (ATAC)**

ATAC provides a process that simplifies DLR Retrograde Movement. It directs NRFI retrograde shipment to a specific Hub activity within designated geographical zones on the East or West coast or to a Transportation Node (e.g., FISC Yokosuka and NAS Sigonella), which consolidates shipments and forwards the consolidated freight to the closest Hub for processing. The Hub provides full technical screening, packing, preservation, and transaction reporting. Hub activities transship retrograde to the appropriate Designated Support Point/Designated Overhaul Point (DSP/DOP) as listed on the Master Repairable Item List (MRIL).

The geographic ATAC Hubs and their support areas are:

FISC Norfolk - All Continental United States (CONUS) activities east of the Mississippi River, all activities on the Gulf Coast and all EXCONUS activities, including afloat forces, west of Diego Garcia.

FISC San Diego - All CONUS activities west of the Mississippi River and all EASTPAC/MIDPAC/WESTPAC activities, including Diego Garcia.

The ATAC concept provides full screening at the ATAC Hub. DLRs under some programs excluded from the ATAC Hub concept. A complete list is provided in NAVSUP P-545. Some examples are Inter-AIMD transfers, aircraft and marine gas turbine engines, small arms, and classified DLRs. (NAVSUP P-545)

### III. AVIATION DEPOT LEVEL REPAIRABLE (AVDLR) ORGANIC REPAIR PROCESSES

#### A. INTRODUCTION

This chapter addresses current AVDLR repair cycle processes by which AVDLRs are inducted and repaired at NADEP NI. The flow of carcasses from the user to the NADEP and the RFI returns to the supply system are discussed. Included in the discussion is the information flow required throughout the process. Section B is described in the first person as if by the AVDLR being repaired to give the reader a better sense of the process a NRFI AVDLR would go through to be returned to RFI condition.

#### B. AVDLR REPAIR PROCESS OVERVIEW

##### 1. Description of the AVDLR Studied

I am an alternating motor for the pitch trim hydraulic actuator for a fin stabilizer on a S-3 ASW jet aircraft. I was manufactured by Allied Signal Aerospace and I am identified by my national stock number (NSN) 6105-01-123-7973. I have a cognizance code (Cog) of 7R, Material Control Code (MCC) of "E" and Special Material

Identification Code (SMIC) of "CS".<sup>2</sup> A SMIC of "CS" means I am a component from the S-3 anti-submarine warfare aircraft. My MCC code of "E" means I am managed under the Intensive Repairable Item Management (IRIM) Program. An explanation of this code is contained in Appendix B. My cog of 7R and my MCC of "E" helps supply and maintenance personnel to identify me quickly as a repairable item. I am also identified by my family group code (FGC) which is BYFA. My standard price is \$6,310 but with a turned-in NRFI carcass the S-3 squadron can buy me for a net price of \$4,520. The procurement cost for a new unit from Allied Signal Aerospace is \$3,680. The cost to repair me at a depot is \$2,790. Worldwide my sisters and I fail 44.62 times per quarter on average. (Ervin, 1997)

I had been designated for repair at NADEP Alameda until it was closed under BRAC on September 30, 1996. Responsibility and capability for my repair was then shifted

---

<sup>2</sup> Special Material Identification Code (SMIC). A two-position alphabetic or alphabetic-numeric code assigned by the Commander, Naval Supply Systems Command, to certain items which require the following controls (see NAVSUP P-485 Appendix 9): 1. Source of quality control. 2. Technical design or configuration control. 3. Special controls for procurement, receipt, inspection, test, or storage. (NAVSUP P-485, 1996)

to NADEP NI. NADEP NI had to take on many of the repair responsibilities formerly accomplished at NADEP Alameda. During this transition period, NADEP NI was unable to accept the increase in repair requirements placed on them. Therefore, as a temporary measure some components of my NSN were sent to Lockheed under contract for repair. Since that time the quantity of RFI assets for my NSN has improved to two quarters of demand on hand. In the future, items will not be sent for commercial repair unless NADEP NI is unable to meet the repair requirements to keep up with customer demand. (Ervin, 1997)

## **2. Organizational Level Process**

When I fail while installed in an S-3 aircraft, the problem is reported by the pilot to the maintenance crew. An aviation mechanic who specializes in hydraulics (rate AMH) will examine the aircraft to determine the source of the problem. He reports the source of the problem to maintenance control. When I am identified as the defective part, an order will be placed for my replacement. My replacement will be issued from onboard stocks, if available, and the aircraft will be repaired at the

organizational level (O-level). If there is no replacement onboard, then an order must be placed off the ship. Sometimes a replacement part is cannibalized from another aircraft. Eventually though, it will have to be replaced in turn using an off-ship order. I will be removed from the aircraft by the AMH and turned over to an aviation storekeeper in the AIMD supply department. The AMH will complete a VID/MAF that is supposed to accompany me throughout the repair process. In reality however this form sometimes gets lost along the way. (Brosch, 1997)

### **3. The Intermediate Level (AIMD)**

The supply department will send me to the Aircraft Intermediate Maintenance Department (AIMD). At the AIMD a technician will test and check me. If I am repaired at the I-level I will be returned to the supply department to replenish onboard spares. If no replacement was issued and the aircraft still has a "hole" (missing component), I will be returned to the squadron for reinstallation in the aircraft. If the AIMD does not have the capability to repair me, they will "BCM" (Beyond the Capability of Maintenance) me and send me back to supply. Supply will

process me as NRFI for shipment to the location determined by the MRIL. In my case this is the appropriate ATAC Hub.

Figure 2 shows a typical flow of an NRFI item from the user to the depot and back to the supply system. This flowchart purposely omits some detail. More graphic detail of the process at North Island are provided in Figure 3.

#### **4. Turn-in/Shipping Document**

In the supply department a DD Form 1348-1 will be prepared citing the requisition number used for my replacement. If my replacement is drawn from onboard spares the DD Form 1348-1 will cite the requisition number used for the stock replenishment requisition. First the storekeeper will look up my NSN on the MRIL to verify that I am a DLR and get shipping instructions. Normally I will be shipped to the ATAC Hub nearest to my geographic location. Appendix C describes the card columns and blocks that the storekeeper will complete on the DD Form 1348-1.

#### **5. Transit to the ATAC**

There are two ATAC hubs, one on the east coast of the U.S. in Norfolk, Virginia and one on the west coast in San Diego, California. Since I am currently located west of the

Mississippi River I will be shipped to the ATAC hub in San Diego.

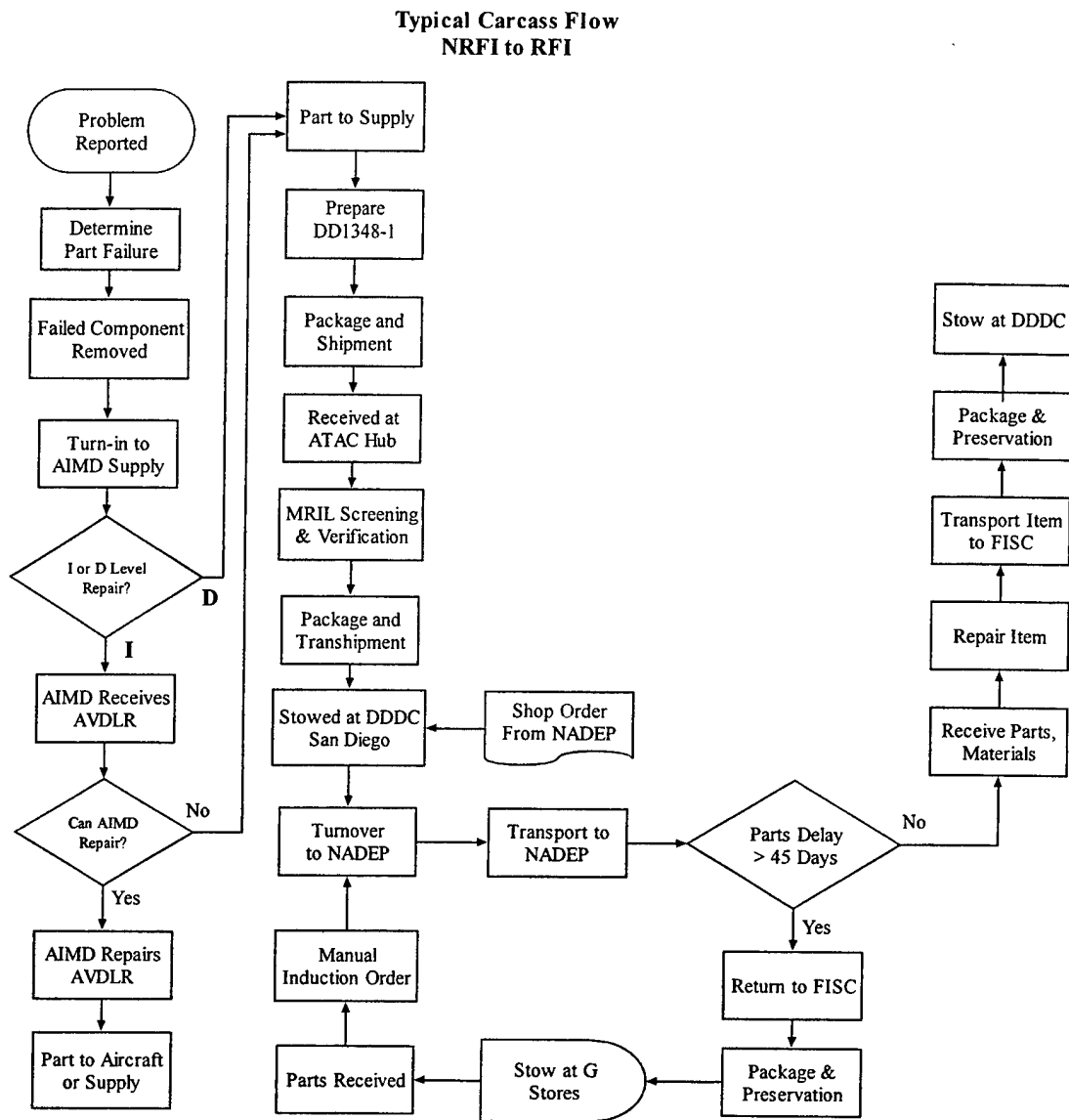

Figure 2. Typical AVDLR Flow for NRFI to RFI

Enroute to the ATAC hub I will make a brief stop at the facility of Morrison-Knudsen, the freight agent that provides the ATAC hub with collection and transportation services. The Morrison-Knudsen has 24 hours to turn me over to the ATAC hub. (McCollough, 1997)

At the ATAC hub, which is operated by FISC San Diego, I will be screened to verify that I am the same component as stated on the documentation. Using the MRIL the technician will verify that I am a repairable and will obtain the shipping address for my designated overhaul point. Since I am designated for repair at NADEP North Island I will be turned over to the Defense Distribution Depot California (DDDC) San Diego which is in the same compound of warehouses at NAS North Island in which the ATAC is located. (McCollough, 1997) The DDDC will put me on the shelf with other "F" condition DLRs to await a shop order from NADEP NI. (Orbin, 1997) If there are too many carcasses accumulating without a significant drop in demand, Aaron Ervin (Code 0316.12), my inventory manager at NAVICP, may send a naval message to have assets redistributed to the commercial depot owned by Lockheed. Since there are

currently enough "A" condition assets on hand for two quarters and NADEP NI is keeping up with additional demand, I will be inducted at NADEP NI when a shop order is issued. (Ervin, 1997)

#### **6. Process to Generate a Shop Order**

Prior to a shop order being issued for my induction there are a number of management processes that occur. I am a "CRC Scheduled component", which means, a schedule is negotiated between NAVICP-P and NADEP NI prior to the beginning of every quarter. The schedule will plan how many of my sisters will be repaired (produced). The process of requirements determination and schedule negotiation is described in Chapter IV.

Kevin Okerman, my P&E (Planner & Estimator) at NADEP NI, will determine when I will be inducted based on the master schedule for me and my sisters. Mr. Okerman worked at NADEP Alameda prior to its closure under BRAC. His office is in Building 36 adjoining the FISC Repairables Branch office in a large building where repairables are processed by the FISC and also contains an the area where packaging and preservation is done by DLA. Mr. Okerman will

request inductions by using the Automated Induction Master Schedule (AIMS) to produce a Weekly Induction Schedule (WIS) from the B08 weekly Probe. He loads his requirements for the following week prior to 1300 on Thursday. The Component Program Office sends the file to the system analyst by 1430. The file is ran and ready for review by Mr. Okerman on the following Friday. (Okerman, 1997)

WIS automatically spreads the requirement over a five day period. Mr. Okerman also has the option of tailoring the spread of the inductions to meet the shop's needs. He must complete the tailored schedule one to five days prior to when the documents are printed. He accomplishes this via the Naval Executive Universal System (NEXUS). He can also schedule inductions by doing a manual override of the WIS. He would use a manual override to induct "G" condition assets when all the piece parts have been received and the carcass is awaiting induction (AWI). (Okerman, 1997)

The induction requirement for me is transmitted to the Naval Computer and Telecommunications Station (NCTS) at San Diego. The requirements are processed the following day and passed to the Operating Documents System (OPDOCS). OPDOCS

produces the printed shop orders the upcoming day. Shop orders are printed at the Defense Automated Printing Service Department. The documents are picked up at approximately 5:00 am by NADEP personnel and then are matched with the job cards. (Orbin, 1997)

The P&E's have an opportunity to edit the OPDOCs file on PECAN (Planner and Estimator Cancellation Program) through PSM (Production Status MAPPER) prior to its transmission to the DDDC. The hard copy shop orders are delivered to the NADEP control point in building 36 where the P&E personnel can remove cancelled orders. The remaining shop orders are valid induction requests and are delivered to the NADEP Central Induction Area (Bldg 662-3). (Orbin, 1997)

The requirements are also passed to the PS MAPPER (Production Status - Maintain, Prepare, Produce, Executive Report) System. The induction image is sent from NCTS to FISC electronically via the Defense Data Access system (DDA). The image is pulled via the Bar Coded Repairables Electronic Exchange Signature (BREES) system which interfaces with the Uniform Automated Data Processing System

(UADPS) and Navy Integrated Storage Tracking and Retrieval System (NISTARS) databases. A ZUA (induction request) is passed to the FISC's UADPS via (BREES). BREES establishes a Repairables Tracking File (RTF). This file accepts, updates, and passes transactions to NISTARS and back to BREES from the start of the induction process to completion. Verification of component availability is made on the UADPS MSIR. (Orbin, 1997)

If the component is available an Aviation Repairables File (ARF) record is established at the FISC and a the MSIR is decremented by a condition code transfer. The ARF is a replica of the RTF established by BREES. The ZUA is then passed to the NISTARS database where the availability of the component is again verified. If the component is available, it displays on the Radio Frequency (RF) handheld unit used by the DDDC warehouseman. DDDC warehouseman Frankie Talabar will pull me from the DDDC stowage location on the afternoon/evening shift. There are four other warehousemen that also perform this function. (Orbin, 1997)

A bar-coded ZUC (Proof of Receipt) DD Form 1348-1 is printed and attached to my stowage container. Mr. Talabar

stages me at the NADEP Central Induction Area (Bldg 662-3) which is collocated within a DDDC warehouse. (Orbin, 1997)

The following day DDDC and NADEP personnel exchange physical custody of me. Alicia Garcia, warehouseman for NADEP, will log on to a handheld Intermec barcode scanner with the Mr. Talabar. They then scan the bar-coded DD Form 1348-1 ZUC document. There are three NADEP warehousemen that perform that function. The data is then uploaded to the system and a TIR signaling the beginning of repair turnaround time (RTAT) is generated. TIRs are transmitted to NAVICP daily. At this point my condition code is changed from "F" to "M". The shop orders and job cards are attached to me and I am then transported by FISC truck driver Mike Hurley to the NADEP dispatch station. (Orbin, 1997)

#### **7. Initial Evaluation by NADEP Shop**

The NADEP has dispatch stations in nearly every building of the 27 buildings where components are repaired. The dispatch station acts as a central shipping and receiving area for all work centers in the building. Once at building 378 where I will be repaired the Production Controller (PC), Doc Dougherty, will make Work in Process

Inventory Control System (WIPICS) and MAPPER entries to document my arrival. He will transfer me to the shop foreman, Jesus Navarro, who will assign me to an artisan if an artisan is available. If an artisan is not available I will go into the local backlog until one becomes available.

The artisan that is assigned either goes to the shop's receiving area and picks me up or I may be delivered to the shop. The artisan will go through the job card and evaluate me. He will test me and determine what parts he needs to repair me. He will go to the Focus Store in his building to draw the parts from Mr. C. Ford. If the parts are available he will pick the parts up from Mr. Ford. If Focus does not have the parts Mr. Ford will check the availability of them with the other Focus stores at the NADEP. (Dougherty, 1997)

If the parts are still not available at the NADEP, requisitions will be placed by the equipment specialists. The equipment specialists, who are FISC personnel, are located in the resource centers at the NADEP. If there is going to be a delay of 45 days or more in getting the parts, as determined from status provided by FISC, I will be

removed from the shop and processed for transfer to "G" condition. (Orbin, 1997)

#### **8. Transfer to "G" Condition**

If I am to be transferred to "G" condition I will be returned to the dispatch center. At the dispatch center my return to FISC will be entered in WIPICS. I will then be picked up by the FISC truck driver and taken to building 36. At building 36 I will be scanned again and my data updated in BREES to change custody. This also stops the RTAT clock. I will then be moved to the packaging & preservation area operated by DLA within building 36 for packaging. (Orbin, 1997)

I will be transported to the FISC "G" stores area in building 661. "G" stores is located in the same warehouse as the ATAC hub. At the "G" stores I will be stowed on a shelf to await the arrival of the parts I need. If I were a large item I may have to be stowed outside in the weather alongside the warehouse. (Deguzeman, 1997)

Accounting of the carcasses and required piece parts is maintained on an automated system called G Man. The G stores personnel maintain cabinets containing over 7,000

line items of piece parts that have been received for carcasses. Currently there are approximately 3,000 carcasses at G stores awaiting piece parts. (Deguzeman, 1997)

When they receive all the parts needed for me, my P&E, Mr. Okerman can have me reinducted. They may take parts that were destined for another component and give them to me if it will allow me to be reinducted. FISC runs the automated Swap program twice per month (1<sup>st</sup> and 15<sup>th</sup>) to determine if parts destined for one component may be swapped to another component so that a component will have all the parts needed to be inducted. The outstanding requisitions can be swapped from the record of one component to another. (Orbin, 1997)

When all the required piece parts have been received for a carcass, and a shop order is issued by the P&E for induction, the carcass will be pulled from the shelf and staged with the piece parts for transfer of custody and transport to the NADEP. At the transfer of custody the RTAT clock is restarted. (Deguzeman, 1997)

**9. Awaiting Parts (AWP)**

If the parts required to repair me are expected to take less than 45 days I will go into AWP status at the NADEP. I will remain in the shop until the parts are received and I am repaired. (Okerman, 1997)

**10. Parts are Available**

If the parts are available at the NADEP, the artisan will disassemble me and make the necessary repairs in accordance with the job card. When the repairs are completed I will be tested again. Then I will be inspected for quality assurance.

Then I will be processed for transport from the building 378 dispatch center to the building 472 dispatch center. Moves between shops are made at 0930 and 1330 and as needed at other times during the day. At building 472 I will be painted. When my painting has been completed and the paint is dry I will be transported from the building 472 dispatch center to the building 378 transport center. Once back at building 378, the Production Controller will make an entry into WIPICS indicating that I am being sent from the repair shop in building 378 to building 36. I will then be

returned to the dispatch center in building 378 for transport to FISC in building 36.

John Franklin, a NADEP warehouseman, will process the paperwork with another entry on WIPICS that I have been turned over to FISC. Rose Cox, a supply technician, receives custody of me from Mr. Franklin on BREES. This will generate a TIR to NAVICP showing that I am now "A" condition and the repair turnaround time clock has stopped. I am then moved to the packing & preservation section on the other side of building 36. Oscar Medina, a DDDC packer, packs me for stowage.<sup>3</sup> I will spend 2 days on average in packaging & preservation and then I will be transported to DDDC by Mike Hurley, FISC truck driver. At the DDDC I will be stowed, issued to another customer, or possibly sent to another distribution center for storage. (Orbin, 1997)

---

<sup>3</sup> Currently the charge for packing & preservation is \$67.00 per item. Recently FISC has bid \$29.00 per item to provide that service. FISC was to take over that operation with the new fiscal year, but the changeover has been delayed. (Orbin, 1997)

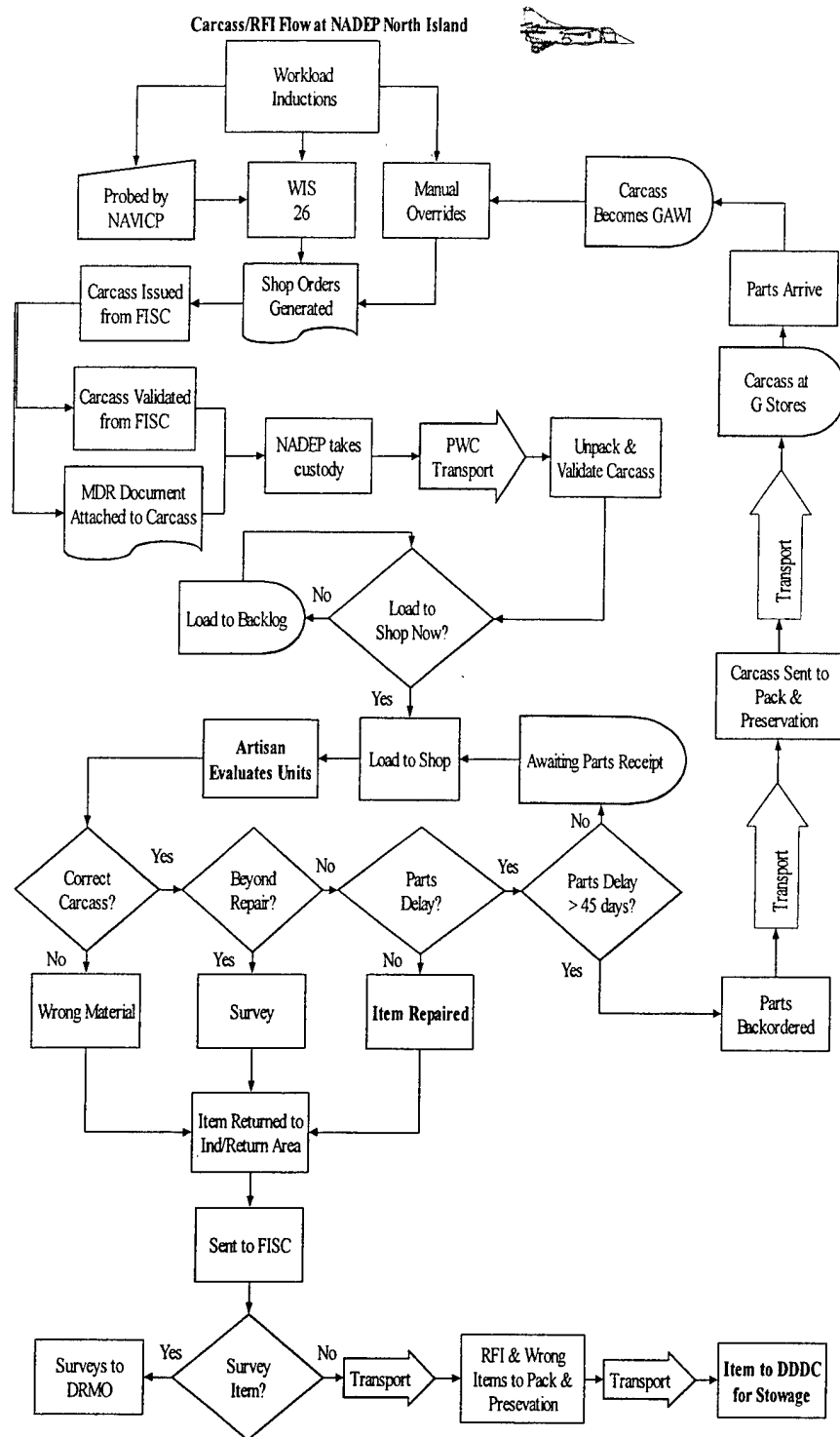

Figure 3. Flow from NRFI to RFI at NADEP NI

#### IV. MANAGEMENT OF AVIATION DEPOT LEVEL REPAIRABLES

##### A. INTRODUCTION

There is a complex set of processes that are followed to order NRFI AVDLRs into the organic depot for induction. This chapter describes those repair management processes at NAVICP-P and NADEP NI. First, we provide background information describing the Program Support Inventory Control Point (PSICP) Concept. Then we discuss repairables management functions and the three organic repair categories. Then we describe those automated programs that are used by NAVICP-P to forecast repair requirements. Next we describe the processes by which those requirements are reviewed and passed to the DOP. In the case of Component Repair Conference (CRC) scheduled items and B08 scheduled items we describe the process for negotiation and acceptance of the quarterly schedule by both the NADEP and NAVICP-P. Finally, we describe the preparations NADEP makes prior to the component repair conference.

**B. PROGRAM SUPPORT INVENTORY CONTROL POINT (PSICP) CONCEPT**

With the PSICP concept, end items under the management of a Hardware Systems Command (HSC) will be supported with component parts by the inventory manager (IM) at the PSICP who accepts supply support responsibility. The IM will either stock the items in the distribution system or ensure that the repair part is available from commercial sources. The cognizant PSICP acts as an agent for the HSC to ensure that all parts required for support of an item are accepted for management by the cognizant IM.

The PSICPs are responsible for provisioning actions, facilitating and coordinating responsive supply support for each item involved, providing information on support of weapons systems and equipment, maintaining configuration data, and providing allowances. These duties require timely interchange of data among IMs concerning equipment population, deployment, afloat and shore maintenance capabilities, and requirements for repair parts support.

In support of the HSCs, the IMs are responsible for accepting program requirements from the PSICP, managing assets in the Navy distribution system, determining

requirements, and preparing material support budgets done via the stratification process.

When the NAVICP is the PSICP, it is responsible for insuring the availability of material needed for support of Navy weapons systems. Their responsibility extends to all items of supply regardless of assigned cognizance symbol. In other words, as PSICP, the NAVICP is just as responsible for the availability of items that it does not manage as for those that it does. This broadened material support accountability makes the role of a PSICP different from that of supply support activities such as DLA centers. The responsibility of DLA centers is restricted to items of supply for which they are the integrated material manager. (NAVSUPINST 4400.89)

### **C. REPAIRABLES MANAGEMENT FUNCTIONS**

PSICPs perform a series of repairables management functions. These are complex decision support functions which are grounded in the understanding of the life cycle operational requirements of the systems.

Based on the maintenance concept for the supported weapon system, repair decisions are formulated to construct

support scenarios that attempt to optimize availability and reduce life cycle cost. PSICPs evaluate depot repair activities based upon performance, economy, facilities, and throughput. Repairs may be performed commercially or organically. This decision depends largely on the maintenance plans for the "parent" weapon system or equipment and the relative costs and capabilities of the repair activities.

Where practical, repairs that are performed commercially early in the life of the weapon system, are later repaired at Navy facilities. PSICPs have a significant role in a successful transition from commercial to organic repair. Navy PSICPs plan for an orderly pipeline of repairable items from the end user to the repair activity and back to stock, and manage repair kits and a rotatable pool of repairable items.

PSICPs also develop the Master Repairable Items List (MRIL) and Master Repairables List (MRL) which list all Navy repairable items and the corresponding repair location(s). The MRIL is a key management tool used in getting NRFI material from the end user to the DOP. The accuracy of the

MRIL and the timeliness of updates has a significant impact on repair cycle time. (NAVSUPINST.4400.89)

#### **D. ORGANIC REPAIR MANAGEMENT PROGRAMS**

There are three repair management programs for organic repair of AVDLRs:

- Component Repair Conference (CRC) Scheduled items.
- B08 Scheduled Items
- B08 Unscheduled Items.

##### **1. CRC Scheduled Items**

The term CRC Scheduled items has recently replaced the more well known term, Level-Scheduled Items. The concept currently remains the same, however, the scope of items included in CRC Scheduled Items is planned to include B08 Scheduled items in the future. (Hill, 1997) CRC Scheduled Items are those 7R and 4R cog items which account for a large expenditure of repair dollars and/or are fast movers that are critical to fleet operations. They account for approximately 80% of the items repaired at organic depots. To maximize production economies, the use of a specialized repair scheduling technique is warranted. To be accepted

for CRC Scheduling each candidate must have a quarterly demand of 25 or more and/or an annual rework value equal to or greater than \$150,000. (ASOINST 4710.15A, 1988)

New candidates for addition to the CRC Scheduling program are received by NAVICP-P from the NADEPs. NAVICP-P also screens items annually to add or drop items from CRC Scheduling. In this process the candidates are sent to the weapons branches for review and feedback to the Industrial Support Branch. Normally items will not drop from the program unless there is a dramatic drop in demand. (Hill, 1997)

## **2. Overview of B08 Items**

B08 managed items comprise the remaining items, i.e. those not managed under CRC Scheduling. B08 requirements are further divided into two management categories; B08 Scheduled and B08 Unscheduled. B08 items are also stratified into four urgency of need levels designated as levels one through four. (Patzman, 1997)

Level one is used for requirements from backorders and NF referrals for priority one requisitions for Not Mission Capable Supply (NMCS), Partial Mission Capable Supply

(PMCS), and approved special projects.<sup>4</sup> NF referrals are backordered requisitions that are sent to the Designated Support Point while the NRFI item is still in "M" condition. A DD Form 1348-1 is printed out by the DSP for the item so that it goes direct to the customer instead of to a stowage location.

Level two is used for backorders and NF referrals of end use AVDLRs, project code 705, Non-Reporters' Fund Code 26, and Planned Program Requirements (PPRs) continually due (except purpose codes L and W and mobilization). Project code 705 signifies work stoppage. Fund code 26 is used for stock documents. A purpose code of L signifies general wholesale items. A purpose code of W signifies pack-up kit items.

Level three is used for Balance Reporters' (all TIRs stock reporters) Stock Backorders, Mobilization

---

<sup>4</sup> NF is a status code that has dual usage. When used with a Referral Order (A4\_), it means "Fill requirement from material scheduled on overhaul/repair or production program of your activity." When used with Supply Status (AE\_), it means "Item backordered at activity (routing identifier is shown in card columns 67-69) against material due from scheduled overhaul/repair. (NAVSUP P-409, 1996)

Requirements, Planned Program Requirements (PPRs) due during Repair-Turn-Around-Time (RTAT), and RTAT Demand.

Level four is used for PPRs due during Repair Objective (RO) (Variable number of days predicted by the Budget Execution Plan), Maximum of either Economic Repair Quantity (ERQ) plus Safety Level or RO Demand. (ASOINST 4710.15A, 1988) RO is the period of time over which the requirement is being forecasted. In the case of B08 requirements it is RTAT plus 90 days.

### **3. B08 Scheduled Items**

In the third quarter of FY 96 the quarterly scheduling of B08 items was prototyped at NADEP Jax. In the first quarter of FY 97 this practice was begun for all NADEPs. This practice is now called B08 Scheduled. B08 scheduled items account for approximately 75% of total B08 item repairs. (Hill, 1997)

### **4. B08 Unscheduled Items**

The remaining B08 unscheduled requirements are submitted to the NADEP via the B08 Probe on a weekly basis. They account for approximately 20% of all forecasted B08 items. They are called unscheduled because they are not

scheduled prior to the beginning of the quarter. The unscheduled items are transmitted weekly to the NADEP. The NADEP schedules their induction for repair on a weekly basis. Current funding levels and repair capacities at the NADEPs have resulted in primarily repairs of level one items and sometimes level two items. (Hill, 1997)

#### **E. UICP OVERVIEW**

The system of computer files, programs, and reports used by the NAVICP-M and NAVICP-P for inventory management is known as the Uniform Inventory Control Program (UICP) system<sup>5</sup>. UICP was developed in 1965 to provide a standard system to be used at all NAVSUP ICPs. The Fleet Material Support Office (FMSO) under the direction of NAVSUP is responsible for the system design, ADP analysis, programming and documentation of the UICP system. (NAVSUP P-553, 1983)

---

<sup>5</sup> UICP is spelled out differently in various publications and instructions. For example, in the Data Maintenance Manual (ASOINST P4440.60E) it is called the Uniform Automated Data Processing System-Inventory Control Point). In the FMSO PD-82 Program Specification (N9312-H51-2293, June 1997) it is called Uniform Inventory Control Program. ASO Instruction P4000.24 is called the Uniform Inventory Control Point Replenishment Requirements Determination Manual.

Over the last 32 years many changes have been made to the programs and files that make up UICP. The largest changes occurred with the resystemization started in late 1970s. The hardware replacement that was planned under resystemization was completed in the mid to late 1980s. Unfortunately, funding for the planned software revisions did not last through completion of the project. The project was discontinued after 5 years, several years prior to completion.

Program modules that were under development to completely replace the computations done by the D01 (Levels) program module were not completed. Today, some computations are currently done in the newer program modules (PD82 and PD80) and others are done in the older D01. These two modules, along with some other modules that were never completed, were intended to completely replace D01.

Additionally, there have been computer programs that were developed by NAVICP-P specifically for repairables management. The result is a complicated system of programs calling on each other throughout various parts of the levels computation process, and locally developed programs that

pull data computed in levels and manipulate it to produce decision information. Some results of computations made by UICP, for example repair level, are ignored by NAVICP-P. Forecasts for CRC scheduled, DMISA, and commercially repaired AVDLRs are made instead by a unique program known as C-LIST at Work. Additionally, all B08 forecasts are not made by the newer PD82 program but are computed in the B08 program. (McKrell, 1997)

The plan for the future is that both ICPs will compute repair forecasts using the new PR12 program fed to a Tier II Oracle repair toolkit. Originally the PR12 program was developed for repair requirement forecasting as part of the resystimization project of the 1970s and 1980s. NAVICP-P does not use the old PR12 version. The new PR12 is planned to be used by both NAVICP-M and NAVICP-P for repair requirement forecasting. A significant improvement of this new program over the current repair forecasting will be that the mathematical computations used in the repair toolkit will be identical to that in the new PR12 program.

## **F. UICP FILES**

There are three data files that play a major role in storing data used to make repairables management decisions. They are the Repairables Management File (RMF), Master Data File (MDF), and Repairables Event File (REF). The following sections describe these files.

### **1. Master Data File (MDF)**

The MDF contains data related to all ICP managed and stocked items. There are over 400 data elements for each item in the file. The data elements describe nearly all of the important characteristics of the items. These characteristics include technical factors and requirements determination related information. The elements include unit of issue, nomenclature, length and cubic measure, procurement method, due-in assets, on-hand assets, demand observations and forecasts, repair turnaround forecasts, unit costs, etc. For DLRs some data elements are contained in the RMF. (NAVSUP P-553, 1983)

### **2. Repairables Management File (RMF)**

The RMF contains many data elements representing item characteristics and data elements which were formally in the MDF. The elements associated with requirements determination

are used to describe repair performance such as inductions, completions, surveys, times, etc. The RMF is an online file whose primary entry key is the NIIN. An entry in this file is established for every AVDLR item. (NAVSUP P-553, 1983)

### **3. Repairables Event File (REF)**

The REF contains data used in the day-to-day control of the repair process. This data includes the tracking of returns of NRFI carcasses, redistribution of carcasses, carcasses in the repair processes, and fund expenditures. (NAVSUP P-553, 1983)

## **G. UICP PROGRAMS (SOFTWARE APPLICATIONS)**

### **1. Requisition Processing (B01)**

B01 processes those requisitions that are forwarded to NAVICP-P by stock points or customers when the stock point is unable to fill a customer's requisition from stock. B01 examines the MDF to locate assets available to meet the need and refers the requisition to a stock point if any, that has sufficient assets to meet the requirement. B01 impacts the requirements determination process by:

- Updating those RMF and MDF data elements which reflect demand observations for the referred requisitions.

- Establishing records for the referred requisitions in the Due-in/Due-out File (DDF).
- Updating MDF and Backorder File data elements when the ICP cannot immediately fill the customer's demand. (NAVSUP P-553, 1983)

## **2. Transaction Item Reporting (B04)**

B04, normally called TIR, is the means by which the UICP files obtain most of its raw data. (NAVSUP P-553, 1983) Transaction Item Reports (TIRs) are, in effect, highly standardized digital messages from stock points, designated overhaul points and other sources. These messages are sent over computer networks to UICP and report each issue, procurement receipt, induction, carcass receipt, receipt from repair, disposal, adjustment, etc. In the case of NADEP NI the TIRs are reported daily by its supporting Designated Support Point (DSP) which is FISC San Diego. (Orbin, 1997)

## **3. Repairables Management Data System (B35)**

For the purpose of this thesis we focus on the B35 function that forecasts repair turnaround time (RTAT) every two weeks. B35 computes RTAT using each observation and applies tolerances. Outliers are then determined based on

tolerance filters. If the observation is less than 5% or greater than 150% of current field data, the Industrial Support Branch reviews the data set to determine if the observation should be ignored. For out of tolerance observations the "G" condition time is subtracted out to bring it in tolerance. If subtracting the "G" condition time does not bring it in tolerance the observation is ignored. The RTAT computed by B35 will be used in computing levels in the D01 application. (Cruice, 1997)

**a. RTAT**

It is useful at this point to discuss RTAT policy. DOD promulgated to all Services the segments which comprise the repair cycle time along with their generic definitions. These segments include retrograde time, administrative time, and depot maintenance time. (Kiebler, 1996) Although retrograde time is considered part of the total repair cycle time by DOD, it is not included as part of the Navy calculated turnaround time because the ICPs often do not have the date of the failure of the item. Usually the first date data available is the date of arrival at the ATAC system.

The depot maintenance time segment for Navy is considered RTAT. RTAT begins on the date when the condition code transfers from "F" to "M". This is reported by TIR to the ICP by the DSP. RTAT ends on the date when an item has been returned by a depot maintenance activity to the supply system in a serviceable condition, and is first by the DSP to NAVICP as "A" condition (RFI).

There are three measurement points for RTAT. The first is the date when the condition code changes from suspended (in work) ("M") to serviceable and the ready-for-issue ("A") is TIRed by the DSP to the ICP.

The second is the "Completion Date" (or "Shipped Date," "DD-250 signature date") reported by non-TIR commercial/interservice depot maintenance activities in status reports to the ICP.

The third is the transfer to ("G" Condition Code). This allows Awaiting Parts (AWP) time measurement, which will be included in the calculation of the RTAT time segment. (NAVSUPINST 4400.89, 1990)

**b. RTAT Goals**

Currently the goal for organic repair RTAT as determined by the NAVICP-P Strategic Planning Committee is to reduce RTAT by 5% per year. Additionally, NAVSUP has prescribed a goal of 41.30 days for average organic repair RTAT by the year 2000. The average organic repair RTAT for FY 94 was 50 days. It climbed to 55 days in FY 95, dropped to 51 days in FY 96, and climbed again to 54 days in FY 97. Although the RTAT goals are set and RTAT is monitored there is not a great deal of importance placed on meeting those goals. (Clarke, 1997)

**4. Levels Program**

The levels program forecasts several key requirements determination elements such as demand, procurement lead time, requisition frequency, repair turnaround time, carcass return rate, and survival rate. Using these forecasts, the program computes wholesale requirements levels such as reorder point, order quantity, and repair level. At NAVICP-P the repair level computed by levels is ignored. NAVICP-P uses the output from a unique program that runs all CRC scheduled organic repair requirements forecasts as well as

commercial and DMISA repair requirements forecasts. The unique program called C-list at Work runs three separate formulas in one program. The three formulas forecast repair requirements for organic repair, commercial repair, and DMISA repair. (McKrell, 1997)

**5. Supply Demand Review (SDR) Program.**

The SDR Program compares current inventory assets to requirements (levels) and makes recommendations to purchase, terminate a purchase, expedite a purchase, redistribute on-hand assets, or recall material from disposal. The SDR recommendations stem from the net asset position for the item. SDR is run quarterly after Levels and anytime during the quarter at the request of one of the NAVICP-P branches. (NAVSUPINST 4400.89, 1990)

**6. Cyclic Repairables Management (B08) Program**

The B08 Program computes repair requirements for DLRs (not included in negotiated, level-scheduled repair programs) using a computerized set of equations and decision rules. The program produces repair recommendations, referral order recommendations for items to be repaired commercially or at non-TIR activities, and redistribution recommendations

when a DOP needs carcasses that are located at another DOP or supply activity. As part of the UICP system, B08 computes the total system shortfall as it relates to current and historical Fleet demands. This system shortfall is provided in the form of induction repair requirements. (NAVSUPINST 4400.89, 1990)

#### **7. Economy of Repair**

IMs at the ICPs currently conduct Economy of Repair Analysis on an annual basis. This analysis is based on data collected during each annual price update, and is provided by the G02 Pricing Program. NAVAIR sends NAVICP-P a file with the component unit price (CUP) for each item. That price is based on costs for repair at the organic depots. If the item is only repaired at an organic depot then NAVICP-P uses the CUP. If the item is repaired using other sources then NAVICP-P uses an average of all the prices.

The purpose of the Economy of Repair review is to identify those items with a repair cost equal to, or exceeding, 100 percent of replacement cost. Upon review, inventory managers determine the desirability of changing the status of the item from repairable to consumable

management. Recommendations for transferring items from DLR to consumable status are sent to the applicable Hardware Systems Command (HSC) along with all relevant data for a level-of-repair review. (NAVSUPINST 4400.89, 1990)

#### **H. CYCLICAL LEVELS FORECASTING STRING**

The purpose of the cyclical levels forecasting string is to forecast quarterly demand, procurement lead time, repair turnaround time and repair cycle time. This software uses data collected in the RMF and MDF to compute the forecasts. This string of programs is run quarterly near the beginning of the quarter. Additionally, recomputations are run twice weekly. Recomputations provide interim updates throughout the quarter and update the MDF. The primary data input to the string are the result of TIRs sent to NAVICP-P from reporting activities. Some of these transactions include requisitions, turn-ins, inductions, repair completions, surveys, and disposal actions. These transactions are stored in the Master Data File (MDF) and the Repairables Management File (RMF). (McKrell, 1997)

Forecasting is the first step in the cyclical levels & forecasting string. Forecasts are made for quarterly

demand, lead time, repair turnaround time, PTAT<sup>6</sup>, and repair cycle time. Basically, everything that is needed to make a decision to buy or repair is forecasted. (McKrell, 1997)

#### **I. C-LIST AT WORK**

C-LIST at Work is the program used by NAVICP-P to compute the repair requirements for organic (CRC Scheduled), commercial, and DMISA repairs. This program was developed at NAVICP-P. C-LIST at Work does not use actual EOQ computations but instead simulates those computations. Input data for the computations is drawn from the mainframe files which had previously been updated by the D01 program. C-LIST at Work is not used for items that are managed under the B08 program. (Hill, 1997)

#### **J. SCHEDULED ORGANIC REPAIR EXECUTION PROCESS**

The scheduled organic repair execution process uses the requirements obtained from C-LIST at Work and develop a schedule for the next quarter at the NADEPs. Additionally, a preliminary schedule for the quarter after the next quarter will be provided. In describing this process we

---

<sup>6</sup> Four days are added to RTAT to determine PTAT. (McKrell, 1997)

measure the planning time backwards from the beginning of the quarter being scheduled. The beginning of that quarter will be referred to as "time zero" or "T-0".

D01 (Levels) is run at T-18 weeks. The C-LIST at Work computation is run at T-16 weeks. At T-15 weeks a quality assurance review or Depot Advocate Review is conducted by the Industrial Support Branch's Depot Support Branch. The Integrated Weapons Support Teams (IWSTs) also participate in the review. During this review the requirements will be screened to look for any outliers. Particular attention is paid to those items that are repaired at more than one facility. These requirements should be reviewed to ensure that requirements for a depot, either organic, DMISA, or Commercial, are not overstated because repair at another facility was not taken into consideration. This must be done with adjustments by the item managers in the C-List program. (Hill, 1997)

After the QA process is complete the requirements are sent electronically to the DOP and HSC (normally NAVAIR for AVDLRs) at T-12 weeks. The DOP will review the requirements and return their responses at T-10 weeks. The DOP will

include the inhibitors with their responses. The inhibitors are those line items where the depot cannot meet the repair level of the requirement. (Patzman, 1997)

There are a number of reasons for the DOP to be unable to meet the requirement. They include carcass unavailability, component piece parts unavailability, DOP capacity limitations, facility limitations, level load inhibited<sup>7</sup>, and others. Statistics are collected by NAVICP-P on the numbers and types of inhibitors for each quarter. (Hill, 1997)

In preparation for the workload conference the preliminary responses from the DOP are reviewed by the Depot Advocates and the IWSTs at T-9 weeks. At T-8 weeks the final preliminary requirements are transmitted to the DOP and to NAVAIR. (Patzman, 1997)

---

<sup>7</sup> Level load inhibited refers to items are not inhibitors per se. The NADEP determines that these requirements should be leveled over two quarters to more evenly spread their workload rather than concentrating a larger portion of the requirement in one quarter. (Hill, 1997)

The Depot Support Branch then builds the conference product using production and MSIR data. They review carcass and parts constrained items to take corrective action such as expediting the delivery of piece parts that are impacting repair. They also research alternate sources, such as commercial contracts, for constrained items. (Hill, 1997)

### SCHEDULED ORGANIC REPAIR EXECUTION PROCESS at NAVICP-P

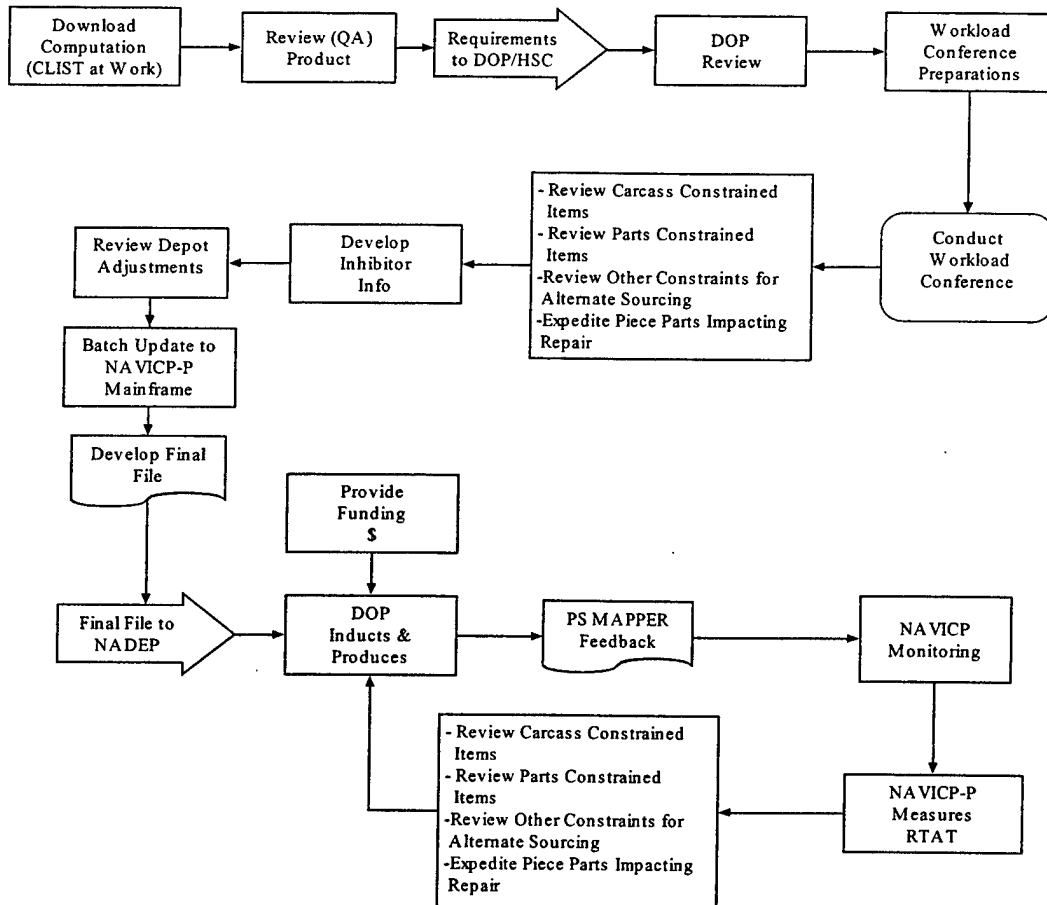

Figure 4. Scheduled Organic Repair Execution

At T-6 weeks the Component Repair Conference is held at NAVICP-P. (Patzman, 1997) The conference is attended by representatives from NAVAIR, NAVICP-P, the three NADEPs, and various customers. Table 2 provides a breakdown of the activities represented and the number of persons representing those activities.

First quarter FY 98 marked the first time the conference was attended by DLA representatives. Their attendance at the conference is an attempt to bring in DLA as an important stakeholder in providing piece parts for the repair of AVDLRs. (Hill, 1997)

The conference lasts for three days. At the conference the requirements for the next quarter are negotiated. Problem areas and inhibitors are discussed and possible solutions developed. At the close of the conference each party will leave with the schedule on diskette. (Hill, 1997)

Following the conference a batch update of the schedule is posted to the mainframe computer. The quantities scheduled are posted in the item notes section on Snapshot, a program that enables access to the mainframe database. (Hill, 1997)

<u>Activity</u>	<u>Number of Attendees</u>
1 <sup>ST</sup> MAW	2
COMNAVAILANT	1
COMNAVIRPAC	3
DISC	1
DLA	1
FISC San Diego	1
HQ AFSOC	1
MALS 14	2
MALS 16	1
MALS 29	1
MALS 31	2
MALS 39	2
MCAS YUMA AZ	1
NADEP Cherry Pt	11
NADEP Jax	7
NADEP NI	5
NAVAIR	10
NAVICP-P	16
WR-ALC	2
<u>WR-ALL</u>	<u>1</u>
Total	71

Table 2. CRC Representation (Patzman, 1997)

During the execution quarter feedback is provided via Production Status - Maintain, Prepare, Produce, Executive Report System (PS MAPPER) and Master Component Rework Control (MCRC) system. MCRC is a NAVAIR consolidated database that contains repair data for all Navy depots.

RTAT is recorded in the RMF and tracked. Continuous reviews are made for constrained items. Those reviews attempt to solve problems related to lack of available carcasses, piece parts shortages, or other constraining issues that arise. (Patzman, 1997)

**K. SCHEDULED B08 REPAIR**

Scheduled B08 repair is also run quarterly. Scheduled B08's requirements are computed by the UICP B08 program. The computation is run at T-5 weeks prior to the start of the execution quarter.

At T-4 weeks the Integrated Weapons Support Team (IWST) reviews the proposed schedule. The revised proposed schedule is then sent to the NADEP. At T-3 weeks the NADEP

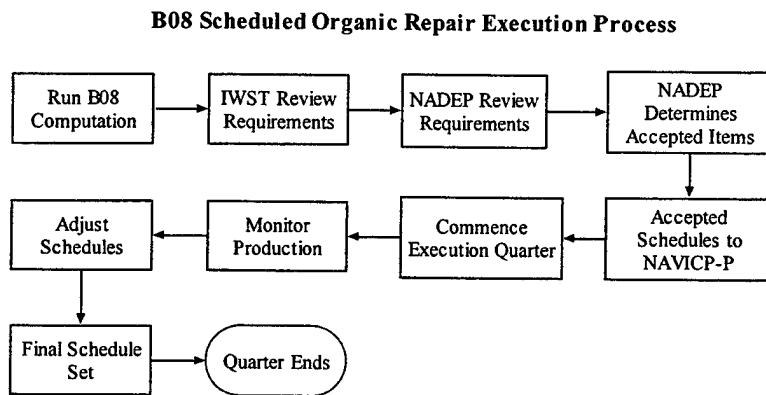

Figure 5. B08 Unscheduled Repair Execution Process

begins its review of the proposed schedule. At T-1 day the accepted schedules from the NADEP are sent to NAVICP-P.

Production is monitored throughout the execution quarter, the NAVICP-P Industrial Support Branch. Adjustments to the schedule are requested by either NADEP or NAVICP-P to either increase or decrease production. (Patzman, 1997)

#### **L. UNSCHEDULED B08 REPAIR**

Unscheduled B08 repair requirements computations are run weekly on the B08 UICP program.

The computation is run Thursday nights to Friday mornings. On Fridays the requirements are transmitted to the NADEP via the B08 Probe. The NADEP reviews and plans inductions. During the following week the NADEP will induct requirements from the B08 Probe. Currently the only way NAVICP-P knows when items are inducted from the B08 Probe is when the items show up as produced. (Patzman, 1997)

#### **M. PROCESS AT NADEP NI FOR SCHEDULED REPAIR NEGOTIATION**

This section describes the process at NADEP NI uses to prepare for the Component Repair Conference (CRC). Information for this section is drawn from the Preliminary

Workload Negotiation Plan for 1<sup>st</sup> quarter and 2<sup>nd</sup> quarter  
 FY98.

**UNSCHEDULED/B08  
 ORGANIC REPAIR  
 SWEEPER**

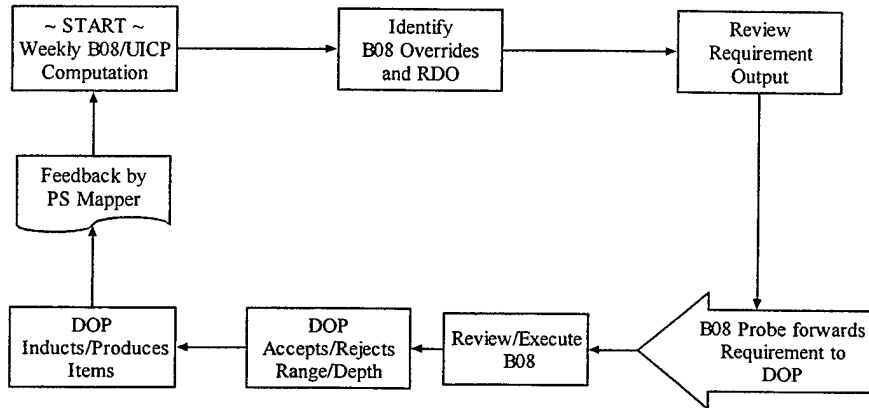

Figure 6. B08 Unscheduled Organic Repair Execution

There are numerous preliminary actions that take place at NADEP NI prior to the Component Repair Conference (CRC). Participation by the entire "Components Team" is mandatory in the preparations for the conference. The negotiation team relies on getting accurate data from the branch personnel to make decisions that affect the quarterly schedule. The milestones for conference preparation are described below.

Consolidated Control Centers (CCCs) and Material Control Centers (MCCs) first identify material concerns for the CRC program. Those concerns are passed by the CCCs/MCCs to their FISC material representatives. The cognizant FISC equipment specialists, who work within the NADEP, initiate CRC Material worksheets. The worksheets include both past and emerging material problems. Upon completion, these problems are reviewed with the respective CCC/MCC team members. A copy is provided to the component planners at the NADEP.

Next the Planner and Estimators (P&Es) review the CRC Program worksheets for accuracy. They then review the worksheets with the respective CCC/MCC team members to determine maximum supportable schedules. When this is complete the P&Es provide the Components Product Management Team Office (PMTO) with a copy of each CRC worksheet.

The Components PMTO reviews the CRC program requirements, for the next quarter and those of the quarter after next, with the respective CCC/MCC. During this review the cognizant Components Planners present issues and concerns using the CRC worksheets as the working document.

At this point it is extremely important that all the CCC/MCC members attend the review. The CCC/MCC members should be prepared to discuss in detail any logistic element constraints that affect NADEP NI's ability to accept NAVICP's requirements. Those constraints may be due to lack of adequate carcasses, piece parts, test equipment, facilities, trade skills, or technical data.

At T-10 weeks the accepted schedules are sent electronically to NAVICP-P. The final preparations are made by the Components PMTO at T-7 weeks. The CRC will be held at T-6 weeks and the negotiation team travels to Philadelphia for the CRC. At the conclusion of the conference each the negotiation team leaves with a final copy of the schedule on diskette.

#### **N. SUMMARY**

An items induction into the NADEP for repair is preceded by processes that employ numerous management tasks, automated data collection and requirements forecasting. There are varied responsibilities and concerns by the different players within each piece of those processes. There are also stakeholders in other activities that have an

interest in which items and how many items are inducted. The results are complex processes that must be repeated quarter after quarter. In Chapter V we analyze those processes.

## V. ANALYSIS OF REPAIR CYCLE PROCESSES

### A. INTRODUCTION

In this chapter we provide an analysis of the processes described in Chapters III and IV. We concentrate on those areas where we have found opportunities for improvement of management practices that could result in either a shorter repair cycle time or reduced costs or both.

### B. SCHEDULED REQUIREMENTS AND COMPUTED REQUIREMENTS

In this section we look at CRC organic scheduled repair requirements as compared to forecasted repair requirements. Table 4 contains data for CRC Scheduled, organically repaired, items for all NADEPs from 3<sup>rd</sup> quarter FY 94 to 1<sup>st</sup> quarter FY 98. Since the 1<sup>st</sup> quarter FY 98 is still in progress at the conclusion of this examination, the actual production quantity is not shown. Figure 8 provides a graphic representation of the data shown in Table 4.

The data clearly shows that actual production consistently lags the final schedule which in turn is significantly lower than the preliminary schedule. There are a number of causes for these differences. In the CRC

scheduling process the differences are categorized in terms of the inhibitors discussed in Chapter IV.

We focus on three underlying causes for the requirements vs. schedule differences. The underlying causes for the differences may result in inhibitors from one or more of the inhibitor categories. The inhibitor categories discussed in Chapter IV include carcass inhibited, parts inhibited, level load inhibited, etc.

**1. Items Repaired at Both Organic and Commercial Depots**

The first cause is related to the way in which the requirement is determined at NAVICP-P. Currently, when the C-List at Work computation is run to determine the requirement for the NADEPs it does not account for the quantities of items also being repaired at commercial depots. (Hill, 1997) Therefore, the requirements for items are overstated. To deal with this inadequacy, the item managers must screen those items which are repaired at both commercial and organic depots carefully and make adjustments to the requirements. Unfortunately this task is not always completed properly and overstated requirements make it to the negotiation process.

Qtr/FY	Scheduled Production			Schedule as	Production as	Production as a
	Preliminary Requirement	Schedule	Production	a % of Requirement	a % of Schedule	% of Requirement
3rd/94	26,951	23,757	21,149	88%	89%	78%
4th/94	25,090	21,149	19,819	84%	94%	79%
1st/95	23,144	19,955	18,485	86%	93%	80%
2nd/95	24,823	19,648	18,133	79%	92%	73%
3rd/95	22,568	18,364	17,399	81%	95%	77%
4th/95	24,812	21,220	19,707	86%	93%	79%
1st/96	28,566	21,299	19,040	75%	89%	67%
2nd/96	29,463	20,618	19,624	70%	95%	67%
3rd/96	30,871	24,635	23,428	80%	95%	76%
4th/96	33,705	26,344	23,608	78%	90%	70%
1st/97	35,459	25,040	21,694	71%	87%	61%
2nd/97	36,289	22,331	19,279	62%	86%	53%
3rd/97	39,602	23,360	22,712	59%	97%	57%
4th/97	37,501	24,154	22,291	64%	92%	59%
1st/98	40,245	25,562		64%		

Table 3. Comparison of Requirements, Schedule, and Production (modified from Patzman, 1997)

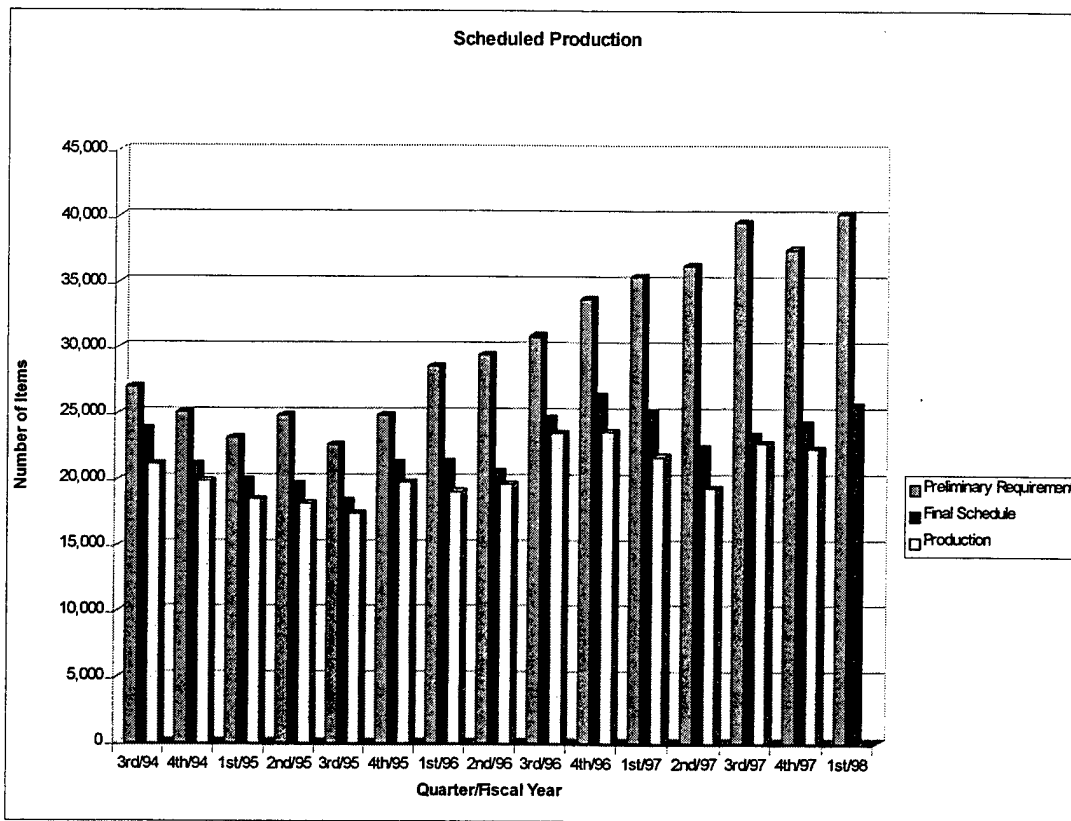

Figure 7. Comparison of Requirements, Schedule, and Production (Patzman, 1997)

The future implementation of the "New" PR12 program is supposed to solve this problem. The new PR12 program should account for items being repaired at commercial sites when computing organic requirements. (Hill, 1997)

## **2. Transition of Organic Depots**

Another cause for the differences between the requirements forecasted by NAVICP-P and the scheduled quantities is due to the transition of repair capacity from depots being closed to those remaining open.

As a result of BRAC-93 the Navy closed three of six NADEPs. The depots at Norfolk, Pensacola, and Alameda were closed. Much of the repair work at the three closed depots was to shifted to the three remaining depots at North Island, Jacksonville, and Cherry Point.

In testimony given before the Subcommittee on Military Readiness of the House National Security Committee on Depot Level Activities, VADM John A. Lockard, Commander, Naval Air Systems Command said:

Directly following the BRAC-93 decision to close three naval aviation depots and realign mission workloads, we developed a plan to expeditiously implement the actions required by BRAC law. Our intent was to minimize the disruption and accelerate the time frame for accruing savings. We successfully completed closing those naval aviation depots and in the process transitioned eight different models of our airframes, three engine product lines, and more than 32,000 components to the remaining naval aviation depots, other service depots, or private industry. (Lockard, 1997)

To shift the capacity to the remaining depots required moving people and equipment. In late 1997 the affects the realignment are still being felt by those planning AVDLR repairs. The general feeling by those we interviewed was that the transition is now reaching an end. (Hill, 1997), (McGuinn, 1997), (Ervin, 1997)

To accommodate the NADEPs during the transition NAVICP-P had been determining quarterly requirements by using an annual computed requirement and dividing by four. This was done to spread the requirement evenly over four quarters. Spreading the annual requirement evenly over four quarters caused the time when backorders could be filled and demand could be satisfied to be continually pushed further into the future in some cases. In those cases the quantities on backorder were greater than the quantities scheduled in one or more quarters. Since the depot was not producing enough

items to keep up with new demands the number of backorders could not be significantly reduced. (Hill, 1997)

To combat the problem of growing backorders NAVICP-P began to determine the requirements differently. Starting with the 1<sup>st</sup> quarter of FY 96 NAVICP-P began front-loading the requirement to the degree by which it was covered by available NRFI assets or projected retrograde regenerations. Front-loading is when NAVICP-P uses the actual forecasted requirement for that quarter rather than averaging the annual requirement. Figure 8 shows the drastic increase in the requirements determined by NAVICP-P. As NAVICP-P's requirements climbed steadily, the scheduled quantities and actual production showed little increase and actually decreasing in some quarters. (Hill, 1997)

The forecasting of projected carcass availability is where NAVICP-P and the NADEPs often have a difference of opinion. There seems to be a general lack of trust at the NADEP that NAVICP-P is accurately forecasting the carcasses that will be available during the quarter being scheduled. Likewise NAVICP-P managers believe that the NADEPS are being

overly conservative in how many carcasses they think will be available. (Hill, 1997)

The mere use of the term "negotiation" implies a process where compromises must be made by some or all of the parties to reach a presumably acceptable schedule. The connotation is that there is one side against another rather than a team effort to reach the best possible solution.

### **3. Assumption "G" Condition Assets Availability**

The C-List requirements computation applies "G" condition assets as units which can be scheduled regardless of whether or not they are awaiting induction (AWI). (Hill 1997) Since the average number of days an item is in "G" condition is approximately 220 days requirements could be computed based on an item's release from "G" condition several times before it is actually released.

By overstating the carcass availability of items in "G" condition, NAVICP-P is attempting to reserve depot capacity for items that cannot be inducted. This depot capacity could be put to better use repairing other items that may have a lower priority. Obviously, the key to solving this problem is to expedite the parts needed to get items out of

"G" condition. Additionally, better information on the number of carcasses that are expected to be released from "G" condition during a quarter would help the planners forecast how many items to plan for induction.

**C. MEASUREMENT OF THE RETROGRADE SEGMENT OF THE REPAIR CYCLE**

The ability to adequately evaluate the effectiveness of a logistics chain depends primarily on the ability to determine the value each activity adds to the chain. Measurements of the numbers of items that flow through the activity and the rate of flow at the activity are important to determining the value of added by the activity.

DOD policy identifies five discrete segments of the Depot Repair Cycle (DRC): retrograde, accumulation, transfer to maintenance, depot maintenance turnaround, and transfer from maintenance. The Navy does not measure these segments individually. The Navy only measures as a single entity, called RTAT, the transfer to maintenance, depot maintenance turnaround, and transfer from maintenance portion of the DRC. (Kiebler, 1996) The first point of measurement of the

RTAT segment is when the TIR is sent to the NAVICP when the item is received by the NADEP at the DSP. (Hill, 1997)

We determined two primary benefits for measuring all segments of the DRC. First, measuring each segment is an important step towards forming an effective logistics strategy. Second, accumulation of data for each segment would allow the forecasting of expected times of arrival for material inbound from various locations. We discuss these two incentives below.

### **1. Formulating Logistics Strategies**

We consider an effective logistics strategy to have three objectives:

- Cost Reduction
- Capital Reduction
- Service Improvement

#### **a. Cost Reduction**

Cost reduction is a strategy that is directed toward minimizing variable costs associated with movement and storage of materiel. The best strategy is based on an evaluation of alternative courses of action. For example, logistics planners could evaluate several warehouse

locations or alternative transportation modes. (Ballou, 1992)

The goal in a military organization would be either maximizing readiness within acceptable cost limitations or minimizing costs within an acceptable level of readiness. In the AVDLR repair cycle, variable cost reductions should be sought in areas such as transportation, packing and preservation, and collection and distribution centers, such as ATAC hubs and nodes.

***b. Capital Reduction Strategy***

A capital reduction strategy would be directed toward minimizing the level of investment in the logistics system. In this strategy the motive is to maximize return on investment. (Ballou, 1992) An example of this strategy might be to send shipments directly to the DSPs to avoid collection and distribution center capital costs. Capital reductions might be found by choosing public warehouses over military owned warehouses or by using third-party providers of logistics services.

A strategy with a lower capital investment, however, may result in higher variable costs but the return

on investment may be increased. For example, DLR shipments could be sent directly to the DSP. This strategy would call for closure of the ATAC Hubs and Nodes and reduce the capital equipment requirements of those activities. This strategy may, however, result in increases in variable costs from misdirected NRFI assets that outweigh any benefit gained by closing the ATACs.

For the Navy, the difficult part is determining how to define what a return on investment is. Normally, the military talks in terms of readiness. Readiness is a vague term that is very difficult to quantify. In terms of readiness, the motive of a capital strategy is to maximize readiness return on capital investment. It quickly becomes obvious that this is not easy to measure.

***c. Service Improvement Strategy***

Service improvement strategies in private sector firms focus on revenues as a function of the level of logistics service provided. (Ballou, 1992) For military organizations we must again turn to the evaluation of how service affects readiness.

Readiness is hard to define in terms of logistics service provided. In Naval Aviation, one way we measure an aircraft's readiness is by its operational availability ( $A_o$ ). Operational availability is the ratio of the time between maintenance to the sum of the time between maintenance and the downtime for maintenance. Quite simply, it is fraction of total time that the aircraft is available for operational use. Operational availability is computed by:

$$A_o = \frac{MTBM}{MTBM+MDT}$$

Where:

$MTBM$  = Mean Time Between Maintenance

$MDT$  = Maintenance Down Time

With:

$$MDT = \bar{M} + LDT + ADT$$

Where:

$\bar{M}$  = Mean Active Maintenance Time

$LDT$  = Logistics Delay Time

$ADT$  = Administrative Delay Time

By examining the formulas for both operational availability and maintenance downtime we can draw some basic conclusions. First, since the maintenance downtime is in the denominator of the operational availability formula, a larger maintenance downtime will result in a lower

operational availability. Additionally, since mean downtime is computed by adding mean active maintenance time, logistics delay time, and administrative delay time, then a larger logistics delay time will result in a larger mean downtime. Therefore, a longer logistics delay time causes a smaller operational availability.

The affect of longer logistics delay times is lower readiness and, therefore, a lower level of service to the customer. Service improvement by way of reducing repair cycle time for AVDLRs means that NRFI units will be transported to the repair facility, repaired, and returned to RFI faster and therefore more readily available when the customer demands it.

The added bonus of a reduction in repair cycle time means that the system would be required to stock fewer units to obtain a given service level. This is because fewer units are needed to cover demand during the repair cycle time.

Of course, another way to increase the service level would be to stock more units from which the customer could draw spares. Given the cost of DLRs this is an

expensive alternative. Additionally, if the failure rate exceeds the repair rate eventually you will run out of RFI units. The result is poor logistics service resulting from a failure of the logistics chain for that item.

**D. INBOUND NRFI TOTAL ASSET VISIBILITY**

Total asset visibility (TAV) as defined by the Joint Total Asset Visibility (JTAV) Office is:

The capability to provide timely and accurate information on the location, movement, status, and identity of units, personnel, equipment, and supplies. It also includes the capability to act upon that information to improve the overall performance of the Department of Defense's (DOD's) logistics practices. (JTAV, 1997)

TAV is a major initiative throughout DOD that, if ever completed, will have a great impact on the way the Navy plans for the repair of AVDLRs. The greatest impact would be better and more timely information that would reduce the uncertainty involved in forecasting the quantity of NRFI assets due-in to the DSPs. Although a detailed discussion of TAV is beyond the scope of this thesis, some important aspects of the program must be mentioned.

The TAV baseline consists of four data repositories.

They are the Logistics Information Processing System (LIPS), Inventory Control Point (ICP) Automated Information System (AIS), the Global Transportation Network (GTN), and the joint theater logistics management AIS that has been designated as JTAV. We will discuss the two that will have the greatest impact on the AVDLR repair cycle, ICP AIS and LIPS.

ICP AIS will provide visibility of assets that are in-storage or in-process (procurement or repair). ICP AIS is planned to have visibility of assets in depot and intermediate level repair facilities. This visibility will be at both organic and commercial depots. Information will be transmitted to the ICP AIS by retail supply, depot-level repair facilities, wholesale distribution depots, and the Defense Reutilization Marketing Service (DRMS).

LIPS is maintained by the Defense Automatic Addressing System (DAASC). It is DOD's central repository for requisition status information. To make LIPS work for the TAV initiative, all requisition and requisition related data to include DLR retrograde shipments and DLR replacement requisitions must be available. (JTAV, 1997)

The key to making TAV work for AVDLRs will be in getting all of these systems to communicate, getting those submitting AVDLR data to provide accurate and timely information, and being able to pull useable information from the data collected.

As mentioned in section C of this Chapter, the Navy does not currently measure the retrograde segment of the DRC. This will cause the move to TAV to be more difficult than it would be if the measurement points were already in place.

The current system does not provide adequate information to inventory managers and NADEP planners to plan inductions for inbound carcasses with much certainty. The ability to forecast repair requirements by increasing the certainty of NRFI assets due-in would be extremely valuable in the repair scheduling process.

The computation for repair requirements uses a forecast of the failure rate per quarter . When the repair schedules are negotiated with the NADEP the most common area of disagreement and the largest category of inhibitors is carcasses availability. Figure 7 shows a graphic

representation of the inhibitors, by classification, as a percentage of the total number of inhibitors for NADEP NI for the 3<sup>rd</sup> quarter of FY 97. This chart shows that carcass unavailability alone accounted for 37% of the inhibited items. The percentage of items that were inhibited by a combination of parts and carcass unavailability was 14%. The combination of those inhibitors is 51% or over half the items can be attributed to carcass unavailability. (Patzman, 1997).

Typically NAVICP-P has a much more optimistic view of the number of carcasses that will be available while NADEP NI takes a more pessimistic view. Visibility of inbound assets would allow both NAVICP-P and NADEP to determine with a higher degree of certainty the number of carcasses currently inbound.

If data were collected on different segments of the logistics chain, NAVICP could also develop forecasts of the time it will take for the carcasses to get from their current location in the chain to the DOP. This would also give the item managers the ability to divert badly needed

NRFI assets via premium transportation directly to the DSP or DOP.

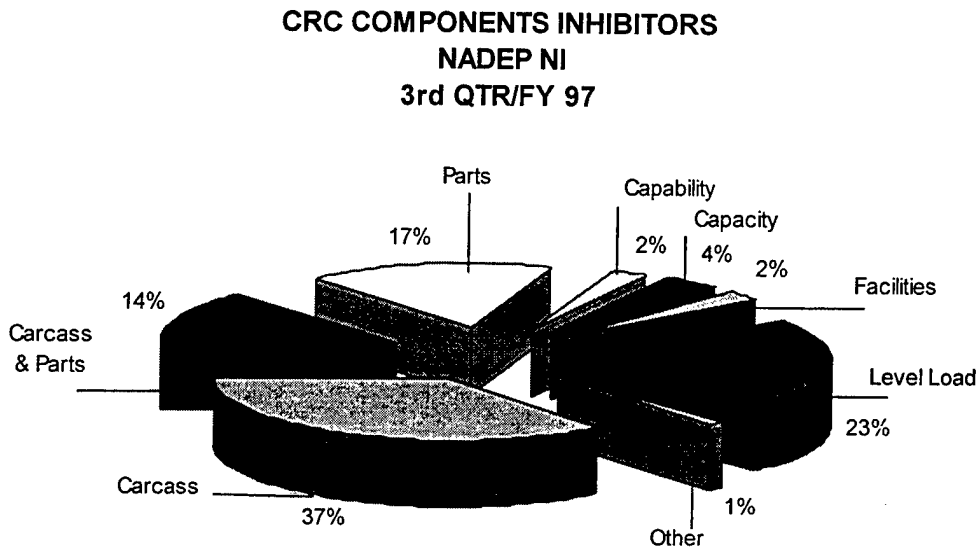

Figure 8. NADEP NI CRC Repair Inhibitors

#### E. NADEP PROCESSES

During the visit to NADEP NI some apparent inefficiencies were noted. We discuss two of those inefficiencies below.

##### 1. Holding RFI Assets Until the New Quarter

During our visit to NADEP NI we became aware of the practice of holding repaired assets above the quarterly schedule to "sell" to NAVICP-P at the beginning of the

following quarter. The incentive to do so is inherent in a process where a quarterly production quantity is scheduled and that quantity is treated as a quota.

When performance is measured based on the ability to meet the schedule, then the shop is motivated to hold items produced near the end of the quarter, that are in excess of the schedule for the current quarter. They then use it toward their next quarter's schedule. This seems innocent enough from the shop's perspective but the impact goes beyond the shop and the NADEP.

By holding the repaired items for an additional amount of time the shops are increasing turnaround time observations for that item. An increase in observed turnaround time causes the B35 program to record a longer turnaround time and therefore forces forecasted turnaround time higher. Since repair requirements are based on the quarterly demand during turnaround time a larger repair requirement will be forecasted to meet future demand.

Another problem caused by overstating turnaround time is a consequence of how B35 computes TAT days. B35 applies tolerances based on filters that flag the outliers.

Basically, if an item's TAT exceeds 150% of the current file data the item is referred to NAVICP-P's Industrial Support Branch.

The Industrial Support Branch reviews the outliers to determine which observations should be excluded from RTAT computation. Time in "G" condition is subtracted out for those observations that exceed 150% of the current file. This is done to reduce the impact of piece parts problems on procurement and repair requirements forecasts. Holding RFI assets in the shop after they have been repaired may cause the observation to be out of tolerance and result in a significant increase in management time and effort. This is time and effort at NAVICP-P that could be better spent solving piece parts or carcass availability problems.

## **2. Unnecessary Steps in the Repair Process**

There was one example of an unnecessary step noted during the visit. That step was discussed in our example flow for an AVDLR in Chapter III and is described below.

After being repaired by the artisan and undergoing quality assurance inspection, the item was transported from building 372 to building 472. At building 472 it was

painted. After painting it was transported back to building 372 only to be processed for return to the supply system. Then the item was transported to FISC SD in building 36 where it goes through the actual turnover process. Transporting items back to the initial repair point in building 372 solely for the reason of paperwork processing or computer entry seems to be an unnecessary step. Repair turnaround time could be shortened by shifting the return processing to the last activity in the repair process rather than returning the item to the primary repair shop.

Additionally there are NADEP personnel, including P&Es, working in building 36. The processing for return to the FISC could be accomplished at building 36 by NADEP personnel. If there are other such opportunities for reducing turnaround time among the other items repaired at NADEP NI, a significant impact could be made in AVDLR stocking requirements.

#### **F. PIECE PARTS AVAILABILITY**

In all of the interviews conducted at NAVICP-P, NADEP NI, and FISC SD the piece parts problem that forces items into "G" condition was at the forefront of subjects that

were discussed. The extent of the problem is exposed by the approximately \$500 million dollars in assets tied up in "G" condition and an average waiting time in "G" condition of 220 days per item.

Since the study of this particular problem is the topic of another thesis currently being written at the Naval Postgraduate School this thesis does not include a detailed analysis of this problem. However, there are a number of issues that are worth mentioning.

First, the procedure for AVDLRs at NADEP NI going to "G" condition is for the items to have the induction reversed and the carcass sent to the "G" store. This process includes additional packing and preservation and transportation. Additionally, there is a significant amount of storage capacity required to warehouse the "G" stores. In fact the warehouse operated by FISC SD is unable to store all of the carcasses within their warehouse space. There are many carcasses that are crated and stowed outside in the weather for long periods of time.

A team of personnel from several organizations at North Island have been formed to make process improvements in the

way the "G" condition material is handled. Members of the team include personnel from FISC SD, NADEP NI, and DDDC. FISC SD has recently claimed that process improvements have led to a reduction in the average number of days an item stays in "G" condition from 220 days down to 195 days. (Orbin, 1997)

#### **G. AUTOMATION OF CRC SCHEDULING**

There are obvious costs associated with the current procedure for scheduling CRC items for repair. The majority of these costs are associated with the thousands of man-hours expended by many DOD activities to complete the process. After the requirements have been forecasted a variety of personnel must complete a series of steps at a number of commands.

Automating the CRC scheduling process has a potential for saving a great deal of time, money, and effort. We believe the key to successful automation is to reduce the number of inhibitors and therefore reduce the conflict over the quantities of items that can be repaired. Since the majority of inhibitors are caused by carcass or piece parts availability, solving a majority of those problems will be a

key issue. Additionally, having better information and less uncertainty on inbound carcasses will allow more accurate forecasting of carcass and piece part requirements. Having more accurate forecasts will reduce the conflict between NAVICP-P and the NADEPs, reduce the need for negotiating schedules, and enhance the ability to automate the scheduling process.

#### **H. COSTS OF COMMERCIAL VS ORGANIC VS DMISA REPAIR**

Table 1 in Chapter I displays the average cost per item associated with the different types of depots. The depots with the highest average cost of repair per item are the commercial depots. There are a number of factors that may cause the difference in costs between the types of depots. First, the commercial depots are often used for the newer state of the art AVDLRs with higher repair costs. Often the organic and DMISA depots do not have the specialized equipment and trained personnel to repair these newer items. Another reason is the difference in the way costs are structured. For instance, commercial repairs include packing & preservation in the repair cost while organic depots do not. Additionally, commercial depots include more

of the management costs associated with the repair, whereas the organic depots do not. (Hill, 1997)

If the Navy is going to encourage competition between commercial and organic depots, it must develop accounting standards that allow the costs for all types of depots to be fairly compared.



## VI. RECOMMENDATIONS, CONCLUSIONS, AND FURTHER STUDY

### A. INTRODUCTION

This chapter addresses conclusions drawn from the research, provides recommendations based on the conclusions, and gives recommendations for further study.

### B. CONCLUSIONS

#### 1. The Processes of the Depot Repair Cycle and Determining Repair Requirements are not Well Documented

This study has provided a certain level of detail in the flow of AVDLRs from NRFI to RFI. Additionally, some level of detail was provided in the descriptions of the management processes used to determine repair requirements and plan repair production. Yet there is still a greater level of detail that can be achieved.

In getting to this level of detail we attempted to analyze the processes we were documenting. We observed that the processes used in repairables management are frequently changed. Many plans for changes are being considered even as this study is being completed. The shift to MRP II at the NADEPs is one such change. This is expected to

significantly affect the way AVDLR repairs are conducted, especially with respect to spare parts planning.

Many instructions involving AVDLRs are a decade or more old. Therefore, much of the research for this thesis had to be accomplished by personal and telephone interviews to validate actual procedures as opposed to those described in instructions and publications. The current documentation used to inform AVDLR managers of the actual processes mainly consists of locally developed flowcharts, process descriptions, and copies of presentation slides. What we found was that the processes and rules change at a much faster rate than the updates to the official guidance.

An original intent of this thesis was to flowchart the computational processes used in AVDLR inventory and repair requirements determination. We found this task to be extremely difficult and beyond the capability of this study. We learned that not only was it beyond our capability but it has eluded the reach of those who have worked directly with the system for many years.

**2. A Significant Gap Exists Between the CRC Scheduled Requirements Forecasted at NAVICP-P and the Scheduled Repairs at the NADEPs**

The data shown in Table 4, and as graphically displayed in Figure 8, reveals a significant gap between the requirements that NAVICP-P proposes to the NADEPs each quarter for CRC Scheduled AVDLRs and the quantities of items accepted in the schedule and the actual production at the NADEPs.

**3. RFI Items Are Sometimes Being Held at the NADEP Prior to the End of a Quarter After the Schedule Has Been Met**

RFI items that are repaired near the end of the quarter that are in excess of the scheduled quantity are sometimes being held at the shops until the start of the following quarter. This causes an artificial increase in the observed RTAT for those items and could increase future repair and procurement requirement forecasts.

**4. Unnecessary Administrative Steps are Performed in the Repair Cycle at NADEP NI**

After the alternating motor we studied in Chapter III was repaired and had undergone a QA check it was transported to another shop in another building. Once painting was completed it was transported again back to the building

where it had been repaired for the final processing. This step seems unnecessary and could be an indicator that other unnecessary steps are also performed.

**5. There is No Visibility of Retrograde Assets Inbound to the DSP**

Currently there is no visibility of inbound retrograde material available to those managing the inventory and repair of AVDLRs. This information could be invaluable in determining and scheduling repair requirements.

**6. Not All Segments and Activities of the Repair Cycle are Measured**

Each segment of the DRC is made up of individual activities. These segments involve processing the items for shipment, or they may involve transportation or holding activities. Although DOD has determined what the segments are and that those segments should be measured, they are not being measured by any of the Armed Services.

**C. RECOMMENDATIONS**

In this section we make six recommendations based on our conclusions that provide an opportunity for improving AVDLR repair and management processes.

**1. Develop Detailed Documentation of the Repair Process and Update Instructions and Publications to Reflect the Actual Processes**

Keeping instructions and publications current in an environment where the processes are rapidly changing is difficult to accomplish. However, intensified efforts should be made to completely document AVDLR repair cycle processes and update related instructions and publications to reflect the actual processes. Instructions and publications should be written so that those handling AVDLRs throughout the process can easily understand what actually occurs in the process.

Process documentation should be made available to those in the AVDLR repair cycle via the latest automated information sources such as those available with the Naval Logistics Library's online service or CD-Rom format.

**2. Narrow the Gap Between Organic Depot Repair Requirements, Schedules, and Production**

Changes should be made to the requirements determination process to more accurately determine a forecast of requirements for the NADEPs. This should be done in several ways:

- Revise the computation to account for quantities repaired at both commercial and organic depots.
- Revise the computation so that a more accurate forecast is made of "G" condition assets becoming available during the planning horizon.
- In the wake of the BRAC-93 transition period, align NADEP capacity to the expected requirement where possible.

### **3. Avoid Holding RFI Items at the NADEP**

When RFI material is produced in excess of the scheduled requirement, the NAVICP-P should be contacted to receive authorization to "sell" those assets back to the system. There should be no artificial increases to RTAT caused by holding those items until the start of a new quarter. Additionally, if excess capacity for an item is available, NAVICP-P should be contacted to increase the scheduled quantity if the item's demand justifies it or shift the capacity to another item of higher priority.

### **4. Eliminate Unnecessary Steps at the NADEP**

Steps that add to the DRC but produce little or no value should be eliminated. Emphasis should be placed on reducing DRC time to reduce the need for additional inventories of AVDLRs and thereby reduce inventory costs.

Administrative steps should be analyzed to determine the value they add to expediting AVDLRs through the repair cycle

**5. Provide Total Asset Visibility of Retrograde Material**

Total Asset Visibility is a top priority throughout DOD. The development of systems to provide total asset visibility should include the visibility of retrograde assets within the repair cycle to allow better planning for DOP inductions. Every effort should be made to ensure that the inputs to the system are timely and accurate.

**6. Measure Each Repair Cycle Activity's and Segment's Processing Times**

We recommend that every activity involved in the AVDLR repair cycle should be measured. With Total Asset Visibility (TAV) implementation this should become feasible.

There are a number of computerized simulation and modeling tools for logistics applications, such as Arena, available on the market today. By accurately measuring the repair cycle activities, actual data can be collected for input to these tools. These tools will enable those making logistics strategy decisions to model modifications to logistics chains on a computer. By doing computer

simulation models, different alternatives can be evaluated prior to making large capital outlays and expending a great deal of time developing the actual logistic chain modification. Additionally, simulated chains could be added and subtracted to assess contingencies for mobilization or demobilization of forces.

**D. FURTHER STUDY**

Additional work or research in the following areas would be beneficial:

- What are the benefits of modeling the AVDLR repair and management processes using a Monte Carlo simulation program?
- What is the affect of outdated instructions on current processes?
- What is the current level of awareness among end users of AVDLRs and those in the repair cycle of the costs of pipeline inventories? Can depot repair cycle time be improved through increased awareness of pipeline inventory costs?

## APPENDIX A

### GLOSSARY OF ACRONYMS AND ABBREVIATIONS

A Condition	Ready For Issue
AIMD	Aircraft Intermediate Maintenance Department
AIMS	Automated Induction Master Schedule
APA	Appropriation Purchases Account
ARF	Aviation Repairables File
ASC	Activity Sequence Code
ATAC	Advanced Traceability and Control
AVDLR	Aviation Depot Level Repairable
AWC	Awaiting Carcass
AWI	Awaiting Induction
AWP	Awaiting Parts
B01	UICP - Requisition Processing
B04	UICP - Transaction Item Reporting
B08	UICP - Repair Scheduling
B35	UICP - Repairables Management Data System
BC1	DOCID for DLR turn-in from end user
BC2	DOCID for DLR turn-in

BCM	Beyond the Capability of Maintenance
BOA	Basic Order Agreements
BREES	Bar coded Repairables Electronic Exchange Signature
CLIST at Work	Program for computing CRC requirements
Cog	Cognizance Code
CONUS	Continental United States
CRC	Component Repair Conference
CTR	Carcass Tracking Record
DBOF	Defense Business Operating Fund
DD1348-1	Requisition/Shipping Document
DD250	DOD Survey Form
DDA	Defense Data Access System
DDDC	Defense Distribution Depot California
DLA	Defense Logistics Agency
DLR	Depot Level Repairable
DOCID	Document Identifier
DOD	Department of Defense
DOP	Designated Overhaul Point
DRC	Depot Repair Cycle
DSP	Designated Support Point

ERQ	Economic Repair Quantity
EXCONUS	Outside of Continental United States
F Condition	Not Ready For Issue
FGC	Family Group Code
FISC	Fleet Industrial Supply Center
FLR	Fleet Level Repairables
FMSO	Fleet Material Support Office
FY	Fiscal Year
G Condition	Awaiting Piece Parts for Repair
G Man	G Condition Material Tracking Program
HSC	Hardware Systems Command
ICP	Inventory Control Point
IM	Inventory Manager
IMA	Intermediate Maintenance Activity
IRRD	Issue Release Receipt Document
M Condition	In an active repair status
MCC	Material Control Code
MDF	Master Data File
MRIL	Master Item Repairables Listing
MSIR	Master Stock Item Record
NADEP	Naval Aviation Depot

NAS	Naval Air Station
NAVICP-M	Naval Inventory Control Point-Mechanicsburg PA
NAVICP-P	Naval Inventory Control Point-Philadelphia PA
NAVSUP	Naval Supply Systems Command
NF	Status Code NF - (DUAL USAGE). When used with a Referral Order (A4_). "Fill requirement from material scheduled on overhaul/repair or production program of your activity." When used with Supply Status (AE_). "Item backordered at activity in rp 67-69 against material due from scheduled overhaul/repair."
NIIN	National Item Identification Number
NISTARS	Naval Inventory Storage Tracking and Retrieval System
NMCS	Not Mission Capable Supply
NRFI	Not Ready For Issue
NSF	Navy Stock Fund
NSN	National Stock Number
OPDOCS	Operating Documents System
OPN	Other Procurement, Navy
OPTAR	Operating Target
P&E	Planner & Estimator
PC	Production Controller
PECAN	Planner & Estimator Cancellation Program

PMCS	Partial Mission Capable Supply
PPRs	Planned Program Requirements
PS MAPPER	Production Status - Maintain, Prepare, Produce, Executive Report System
PSICP	Program Support Inventory Control Point
REF	Repairables Event File
RFI	Ready For Issue
RMF	Repairables Management File
RO	Repair Objective
ROD	Report of Discrepancy
RTAT	Repair Turnaround Time
RTF	Repairables Tracking File
SM&R	Supply Maintenance & Recoverability Code
SMIC	Special Material Identification Code
SRA	Shop Replaceable Assembly
TIR	Transaction Item Report
TYCOM	Type Commander
UADPS	Uniform Automated Data Processing System
UIC	Unit Identification Code
UICP	Uniform Inventory Control Program
VIDS/MAF	Visual Information Display System/Maintenance

Action Form

WIPICS	Work in Process Inventory Control System
WIS	Weekly Induction Schedule
WPN	Weapons Procurement, Navy
WRA	Weapons Replacement Assembly
ZUA	DOCID - Induction Request
ZUB	DOCID - Return of Component from Repair Shop
ZUC	DOCID - Proof of Receipt of Induction
ZUD	DOCID - Component Stowed

## APPENDIX B

### INTENSIVE REPAIRABLE ITEM MANAGEMENT (IRIM)

The Intensive Repairable Item Management (IRIM) Program focuses management attention on those aviation and non-aviation repairables which meet certain cost, criticality, and demand criteria. The IRIM Program supersedes the Fleet Intensified Repairables Management (FIRM), Intensified Closed Loop Aeronautical Management Program (I-CLAMP), and Hi-Burner programs. Detailed procedures are provided in NAVSUPINST 4419.4. IRIM items are identified by Material Control Code "E" in the Master Repairable Item List (MRIL) and the Management List-Navy (ML-N).

Those items selected for intensive item management will be tracked via standard ICP carcass tracking procedures and scheduled for applicable organic or commercial repair. Intensively managed items in "M" or "G" condition will be periodically reviewed and monitored. Appropriate action will be taken for those items with excessive Repair Turn-Around-Time (RTAT). Backorder deficiencies and piece parts shortages will be reviewed, monitored and corrected.

Repetitive Not Mission Capable (NMCS), Partial Mission Capable (PMCS) and Casualty Report (CASREP) requisitions as well as referrals will also be reviewed and monitored to ensure adequate asset availability.

Items will be selected for IRIM based on the following criteria:

1. Demand Drivers/Readiness Degraders. ICPs will select those repairable items with a demand average of greater than one per quarter and which demonstrate insufficient assets to satisfy requirements during the repair cycle. This may be demonstrated as:

- Items demonstrating repetitive NMCS, PMCS or CASREPs.
- Items which are expected to experience repair cycle asset deficiencies within the next six months.
- Items experiencing technical or source problems which preclude or delay the procurement of repair pipeline assets.
- Critical "carcass constrained" items applicable to the top problem equipments.
- Items demonstrating a high ratio of backorders relative to quarterly demand.

2. ICP Special Nominations. ICPS may include repairable items from the following categories:

- Selected items critical to specific weapons systems that do not meet any of the selection criteria stated above; and
- Fleet interest repairables including critical pool material and fleet controlled assets. (NAVSUP P-485, 1996)



APPENDIX C

DD FORM 1348-1 BLOCKS FOR DLR TURN-IN

Card Columns/ Blocks	Description
1-3	BCI Document Identifier
8-22	NSN of NRFI DLR being shipped
23-24	Unit of Issue (U/I)
25-29	Quantity (usually a quantity of one)
30	Service Code (R or V Service Code (R = Pacific/V = Atlantic)
31-35	Unit Identification Code (UIC) of activity turning-in carcass
36-39	Requisition Julian Date
40-43	Requisition Serial Number
55-56	Cognizance Symbol
60-61	Movement Priority Designator (MPD) (Shipment to an ATAC Hub or Node will always be a 03
71	F Condition Code (Usually F for NRFI but could be L for EI/QDR turn-in)
72	E Management Code (E = DLR being returned as result of exchange requisition)
73	Material Control Code (MCC) (MCC of E, G, H, Q or X as indicated in the MRIL)
A	Material Control Code (MCC) (MCC of E, G, H, Q or X as indicated in the MRIL)
B	ATAC Hub address for turn-in activity's geographical location
N	Security Classification (blank = unclassified)
P	Condition Code (F = NRFI/same as cc 71)
V	Job Control Number (JCN)
X	Item's nomenclature, part number and serial number
DD	"REPAIRABLE- All NRFI repairables being shipped to REDSTRIPE" an ATAC Hub or Node
EE	Indicate if additional packaging is necessary
12	Date carcass shipped from turn-in activity
FF-GG	Name, rank/rate for signature of person approving transfer



## LIST OF REFERENCES

Ballou, Ronald H., Business Logistics Management, Prentice Hall, 1992.

Brosch, Bruce, Aviation Maintenance Officer, Personal interview, 24 October 1997

Clarke, Deborah, Deputy Branch Head, NAVICP Program Management Branch (Code 03422a), Personal interview, 08 August 1997.

Cruice, Barbara, Supply Systems Analyst, NAVICP Inventory Management/Retail/Repair Division (Code P0421.70), Personal interview on 07 August 1997.

Deguzeman, Augustan "Gus", FISC San Diego "G" Stores Supervisor, Personal interview, 24 September 1997.

Department of Defense Regulation (DODR) 4140.1-R, DOD Materiel Management Manual, January 1993.

Department of Defense, Joint Total Asset Visibility (JATV) Office, Web Page, <http://204.255.70.40/TAVFA/tav.html>, 02 December 1997.

Department of the Navy, Naval Supply Systems Command Publication 545, Depot Level Repairables (DLR) Requisitioning, Turn-in and Carcass Tracking Guide, February 1989.

Department of the Navy, Naval Supply Systems Command Instruction 4400.89, Navy Repairables Management Manual, April 1990.

Department of the Navy, Naval Supply Systems Command Instruction 4400.96, Responsibilities of the Navy Program Support Inventory Control Point, October 1994.

Department of the Navy, Naval Supply Systems Command Publication 553, Inventory Management.

Department of the Navy, Aviation Supply Office Instruction 4710.15A, Level Schedule Item Repair Requirements Determination, 28 Apr 1988.

Department of the Navy, Aviation Supply Office Instruction 4000.30B, B08 Cyclic Repairable Management Program, 8 Sep 1986.

Department of the Navy, Naval Air Systems Command Instruction 4440.6D, Naval Supply Systems Command Instruction 4440.155D Management of Condition Code "G" Repairable Components, 15 Nov 1988.

Department of the Navy, Naval Air Systems Command Instruction 4400.6A, Pre-Expended Bin Policy and Procedures for Naval Aviation Depots, 27 November 1996.

Department of the Navy, Naval Supply Systems Command, Publication 409, MILSTRIP/MILSTRAP Desk Guide, 19 August 1996

Department of the Navy, Naval Supply Systems Command Publication 485, Afloat Supply Procedures, September 1996.

Dougherty, Doc, NADEP NI Production Controller, Telephone interview, 14 November 1997.

Ervin, Aaron, Inventory Manager, S-3/C-130/E-6 Integrated Weapons Support Team (Code 0316.12), Telephone interview, 10 November 1997.

Fuller, Mike, NADEP NI Component Program Manager, Personal interview, 23 September 1997.

Goodman, Bob, Branch Head, NAVICP Program Management Branch (Code 03422), Personal interview, 07 August 1997.

Hill, Gisela, Assistant Department Head, NAVICP Industrial Support Branch (Code 0342A), Personal interview, 07 August 1997.

Kiebler, Kelvin K., The Depot Repair Cycle Process, Opportunities for Business Practice Improvement, Logistics Management Institute, 1996.

Lockard, John A., VADM, USN, Testimony Before the Subcommittee on Military Readiness of the House National Security Committee on Depot Level Activities, [www.navair.navy.mil/air00/speeches/congtest.html](http://www.navair.navy.mil/air00/speeches/congtest.html), March 18, 1997.

McCollough, Mac, Supervisor, Screening/MRIL Branch (Code 121C), FISC San Diego ATAC Hub, Personal interview, 25 September 1997.

McGuinn, Sue, NAVICP Field Representative at NADEP NI, Personal interview, 23 September 1997.

mackerel, Elizabeth, Supply Systems Analyst, NAVICP Inventory Management/Retail/Repair Division (Code P0421.19), Personal Interview, 06 August 1997.

Okerman, Kevin, NADEP NI Planner & Estimator (Code 93001), Personal interview, 23 September 1997.

Orbin, Marion, FISC San Diego Repairables Branch Manager, Personal interview, 23 and 25 September 1997.

Patzman, Mark, Branch Head, , NAVICP Depot Support Branch (Code 03421), Personal interview, 05 August 1997.



**INITIAL DISTRIBUTION LIST**

		No. of copies
1.	Defense Technical Information Center..... 8725 John J. Kinsman Rd., STE 0944 Ft. Beloved, VA 22060-6218	2
2.	Deadly Knox Library..... Naval Postgraduate School 411 Dyer Rd. Monterey, CA 93943-5101	2
3.	Defense Logistics Studies Information Exchange. U.S. Army Logistics Management College Fort Lee, VA 22134-5130	1
4.	Dr. Thomas P. Moore..... Code SM/MR Naval Postgraduate School 555 Dyer Road Monterey, CA 93943-5103	1
5.	LCDR Dennis L. Baird..... NAVSTA Root Spain PSC 819, Box 8 FPO AE 09645-1600	1
6.	LCDR James Hoover..... NAVICP-Phil (Code P041) 700 Robbins Ave Philadelphia, PA 19111-5098	1
7.	Gisela Hill..... NAVICP-Phil (Code 0342A) 700 Robbins Ave Philadelphia, PA 19111-5098	1