

065236

JPRS-ESA-84-045

13 December 1984

East Europe Report

SCIENCE AND TECHNOLOGY

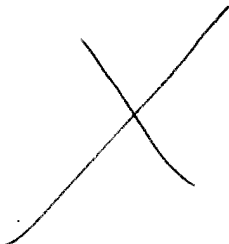

19980429 149

DTIC QUALITY INSPECTED 3

FBIS FOREIGN BROADCAST INFORMATION SERVICE

REPRODUCED BY
NATIONAL TECHNICAL
INFORMATION SERVICE
U.S. DEPARTMENT OF COMMERCE
SPRINGFIELD, VA. 22161

DISTRIBUTION STATEMENT A
Approved for public release;
Distribution Unlimited

5
71
A04

JPRS-ESA-84-045

13 December 1984

East Europe Report

SCIENCE AND TECHNOLOGY

FBIS

FOREIGN BROADCAST INFORMATION SERVICE

REPRODUCED BY
NATIONAL TECHNICAL
INFORMATION SERVICE
U.S. DEPARTMENT OF COMMERCE
SPRINGFIELD, VA. 22161

NOTE

JPRS publications contain information primarily from foreign newspapers, periodicals and books, but also from news agency transmissions and broadcasts. Materials from foreign-language sources are translated; those from English-language sources are transcribed or reprinted, with the original phrasing and other characteristics retained.

Headlines, editorial reports, and material enclosed in brackets [] are supplied by JPRS. Processing indicators such as [Text] or [Excerpt] in the first line of each item, or following the last line of a brief, indicate how the original information was processed. Where no processing indicator is given, the information was summarized or extracted.

Unfamiliar names rendered phonetically or transliterated are enclosed in parentheses. Words or names preceded by a question mark and enclosed in parentheses were not clear in the original but have been supplied as appropriate in context. Other unattributed parenthetical notes within the body of an item originate with the source. Times within items are as given by source.

The contents of this publication in no way represent the policies, views or attitudes of the U.S. Government.

PROCUREMENT OF PUBLICATIONS

JPRS publications may be ordered from the National Technical Information Service, Springfield, Virginia 22161. In ordering, it is recommended that the JPRS number, title, date and author, if applicable, of publication be cited.

Current JPRS publications are announced in Government Reports Announcements issued semi-monthly by the National Technical Information Service, and are listed in the Monthly Catalog of U.S. Government Publications issued by the Superintendent of Documents, U.S. Government Printing Office, Washington, D.C. 20402.

Correspondence pertaining to matters other than procurement may be addressed to Joint Publications Research Service, 1000 North Glebe Road, Arlington, Virginia 22201.

NOTICE

THIS DOCUMENT HAS BEEN REPRODUCED FROM THE BEST COPY FURNISHED US BY THE SPONSORING AGENCY. ALTHOUGH IT IS RECOGNIZED THAT CERTAIN PORTIONS ARE ILLEGIBLE, IT IS BEING RELEASED IN THE INTEREST OF MAKING AVAILABLE AS MUCH INFORMATION AS POSSIBLE.

13 December 1984

EAST EUROPE REPORT SCIENCE AND TECHNOLOGY

CONTENTS

GERMAN DEMOCRATIC REPUBLIC

East Europe's 'Silicon Valley' Increasing Non-Bloc Exports (Disa Hastad; DAGENS NYHETER, 6 Nov 84)	1
Academy of Sciences VP on Modernization, Retraining Needs (Ulrich Hofmann Interview; WOCHENPOST, No 40, 5 Oct 84)	4
New Concepts for Industrial Robots Outlined (H. Scheibner; FERTIGUNGSTECHNIK UND BETRIEB, No 7, 1984)	12
Machine Tools at 1984 Leipzig Spring Fair (FERTIGUNGSTECHNIK UND BETRIEB, No 7, 1984)	25
NC Programming, Machine Tool Information (FERTIGUNGSTECHNIK UND BETRIEB, No 7, 1984)	45
Laser-Guided Measuring System for Precisioning Device (R. Schroeter; FEINGERAETETECHNIK, No 9, 1984)	53
Institute Director on Semiconductor Development (Werner Bertoldi Interview; SPECTRUM, No 9, 1984)	63

EAST EUROPE'S 'SILICON VALLEY' INCREASING NON-BLOC EXPORTS

Stockholm DAGENS NYHETER in Swedish 6 Nov 84 p 39

[Article by Disa Hastad]

[Text] A small idyllic town with half-timbered houses and a ring-wall, at the latitude of Leipzig and Luetzen in that south Germany, which even before the war was the center of the office equipment industry which was rapidly converted into an armament industry.

This is Soemmerda, with 21,000 inhabitants, where one of the most important factories of the GDR computer industry is located.

Thirteen thousand people work here. They are bussed in from a hundred towns and villages in the region.

Microelectronics are intended to become the new backbone of the country. The large Robotron combine, spread over a number of enterprises in the Saxony-Thuringia area at Erfurt, Karl Marxstadt and Dresden, today employs a total of 70,000 persons. It already represents a very important export industry--60 percent of the production is exported, primarily to the Soviet Union, which with its large orders and long production series provides the companies with economic stability as a basis in an industry, where right now the development is progressing by leaps and bounds.

The fact that it was the GDR which grabbed up this field is explained in Berlin and Soemmerda with the argument that there was a basis. The GDR possessed experienced technicians and trained workers, and then there were the old office equipment and weapons factories.

It is somewhat more difficult to get an exact idea of just how good these German electronics are when measured by international standards. Naturally, they are far behind the United States, Japan and the major West-European countries. The reasonable merchandise they produce is adapted to the consumers, however--and many of them want to proceed more slowly than what the manufacturers would like.

"We have a good assortment of chips now--but we do not have everything," says Professor of National Economics Hannelore Petsch, whom I meet in East Berlin.

She is one of those who speak of Robotron as a future industry--but when estimating the GDR's potential it is impossible to get beyond her vague statements.

In Soemmerda people are of the opinion that their own production, above all, which is microcomputers and printers, is holding its own in the market and does not have any competitors--at least not in the CEMA region.

"We could sell our printers to the United States," says marketing chief Karl Stumpp. "It is compatible with all computers, Apple, IBM etc. But in selling to the United States our problem is the high customs duty of 30 percent."

Only a negligible proportion of the production is sold to the West--five percent, and this in order to obtain foreign currency--and the big customer is the Soviet Union, as was mentioned.

In Soemmerda the entire production is civilian, it is said, and the customers who are mentioned are also none but civilian: Gosplan (the central Soviet planning agency), the Central Statistical Organization and Soviet agriculture--all of the them very demanding, according to the director of the Soemmerda works.

China Interesting

In the West it is believed that in the Soviet Union the civilian sector is quite well separated from the military one, and it is possible that it has access to an entirely different technology, with different suppliers.

DAGENS NYHETER asked director Stumpp if maintaining the rather varying levels for the products, as is now done, presents any difficulties: At the moment, large, standard programs with a somewhat obsolete technology are sold to the Soviet Union, at the same time as the company keeps up with today's rapid development in the field and also conducts development work on the side.

"I don't really deal with a "Mongolia level" and a "Soviet level," the director says, "although there are differences, of course. With regard to the Soviet Union, we are grateful--and any company would be--that we have such a faithful partner with such a stable economy."

But now there are attempts to enter new markets as well, and one of the most interesting is China.

"The Soviet Union will remain the biggest partner," he says. "That is also part of our philosophy."

Underdeveloped countries within the CEMA are given aid through participation in the program sponsored by the GDR, as well as by Czechoslovakia: Young Vietnamese and Cubans are trained at the factories and given a profession.

"And anyone who has learned to operate a machine loves it and doesn't want any other," maintains director Stumpp. "That way we obtain new markets."

The Western world offers few of the latter, however. It might be an order for 10 printers to Greece, sometimes five to Indonesia, negligibly small in the context.

"It will be more expensive for us to invent certain parts, for example the components in the motor," says Gunter Kuenssler, head of the computer section. "It costs us time. On the other hand, in spite of inventing the bicycle all over again, so to speak, it develops the industry and the brains are kept alive."

How, then, does the GDR electronics industry get its knowledge--where do the innovations come from?

Director Stumpp replies that research is conducted under the management of the factory, both basic research and applied--and there is also an inventor's school. Advanced school research is also conducted in this area.

'No Espionage'

"And we have no industrial espionage," laughs the director, but continues:

"You know, an invention made in the United States, which I cannot convert into practice in the GDR, that is worth nothing to us. We have to be able to apply it."

The industry now concentrates on licensed manufacture as well and has agreements with China and Yugoslavia, which assemble parts manufactured in the GDR. In Soemmerda most parts are self-produced, but some of the software is obtained from Hungary, such as the diskettes for the printers demonstrated for DAGENS NYHETER.

The task imposed on the Soemmerda works is now to rationalize and to develop their export to the capitalist nations. Perhaps all is not going according to plans but, as Karl Stumpp says, the plans must be a forecasted reality.

Data technology would make the state five-year plans infallible, it was believed 20 years ago in the GDR. It did not turn out quite that favorably.

But the development is on the march in the East.

11949
CSO: 3650/42

GERMAN DEMOCRATIC REPUBLIC

ACADEMY OF SCIENCES VP ON MODERNIZATION, RETRAINING NEEDS

East Berlin WOCHENPOST in German No 40, 5 Oct 84 pp 16-17

[Interview with Prof Dr Ulrich Hofmann, First Vice President, GDR Academy of Sciences, by Horst Hoffmann and Hans Ronneburger: "Strategy of Science, Strategies for Research"; date and place not specified.]

[Text] Question: What do we understand by a strategy of science?

Prof Hofmann: This defines the general course of research in a country, the focal points and main directions, which must be heeded in scientific work at a certain point in time and in accordance with the social-policy goals. To that extent strategy is not synonymous with forecasting, conception, or plan. To put it in simplified terms: Strategic work also presupposes forecasts, but conceptions and plans are developed only on the basis of strategy. It must also show in what way and with the use of what resources primary tasks can be worked out.

Marx and Engels, but above all Lenin, had already applied the concept of strategy, which originally signified "generalship" in the Greek language, to the class struggle of the proletariat and to the work of the party. Today it is used in many other sectors, in the same way that generally speaking findings and results of military strategy are transferred to civilian fields. Instead of the battlefield we speak, for example, of the field of research, of the economic front, and in place of the commander-in-chief or general staff we set up bodies which work out strategies.

If you glance backward at the development of the GDR you will always find in program documents of the party and government also certain declarations of principle about the development of scientific research. Of course, a strategy of science means considerably more today than it did 35 years ago. At that time, with the help of our Soviet friends and comrades we were making the first timid steps in this difficult domain. Today we now have a body of rich experiences to help us in establishing strategically important and correct primary goals in research.

Question: What is the starting point for our science-strategy considerations?

Prof Hofmann: Always and in every case social strategy, which is to say the goal of developing the national economy in connection with an increasingly beneficial relationship between effort and result and thus systematically raising the material and cultural living standards of the people. Then appropriate to this social strategy is the respective economic strategy, from which finally we derive the general strategy for science and technology. Following from this in turn are fundamental research tasks for the Academy, the universities and colleges, and for industry. To express it differently: In its strategy the Academy is guided by the needs of the socialist society and by the principles of science and technology. We do not pursue research solely for the sake of research, but in order to be useful to society. However, research does not only satisfy needs, but itself awakens new ones.

Question: Can you explain in somewhat more detail the interaction between social, economic, and scientific strategy?

Prof Hofmann: If we recognize--and who would want to doubt this--that the above-named social strategy, namely the unity of economic and social policy, requires the shifting of the entire national economy to an intensively expanded reproduction process, then the Academy, for example, must concern itself on a priority basis with the increased processing of raw materials, industrial materials, and products.

If it is a fact that in contrast to domestic brown coal petroleum and natural gas are available only to a more limited degree, we simply must concentrate on coal upgrading.

And if it is beyond all doubt that automation, that computer-aided work places are on the way in everywhere in the world, then it is of strategic importance that we develop microelectronics and computer science more and more rapidly. Here the credo of the scientist must be: Think of what nobody has yet thought of before you; explore what nobody has yet explored before; discover what has not yet been discovered! In order to be able to measure up to this high demand on his work, he must know accurately where in his field the most forward front lies and where he could have a prospect for success with his activity. He must carefully analyze his own strengths. Because before I know where I stand, of what I am capable, and what the basic given conditions are, I cannot define any direction of thrust. What is more: I must correctly estimate the powers both of my allies and also of my rivals. Finally, I need an accurate knowledge of where developments are heading internationally, and I must take into consideration the political goals and requirements of my own country. But the thing which is not least essential is: Only the person who is himself in active research is in a position to contribute to the working out of scientific strategies.

Question: In your opinion, what is the most important thing about the world standards comparison which is requisite for this?

Prof Hofmann: Permit me first of all to say what the worst thing would be: To set oneself a task which has already been worked out elsewhere! Unless

it is a question of a really masterful re-creation or adaptation with the intent being here to create something even better. It is also essential, and especially in science, that one measure himself by the best. I see one reason for a great deal of loss in speed as lying in the fact that we have not always consistently enough searched for and carried out this international comparison. It simply is not enough to compare findings or even products with one another when they are already on hand. Then it may already be too late, then it is often the case that one must follow along behind. The comparison with what is most advanced must begin already with the setting of the tasks, in fact really even with the conceiving process.

Question: But surely not everything which is conceivable is also practicable?!

Prof Hofmann: In view of the infinitude of the universe, tasks as well can be set in boundless profusion. Thus one must make a choice, and in fact the right one. This can already be a decisive step toward a solution. The negative aspect of the dialectical contradiction between the conceivable and the practicable lies in the fact that one's forces are sometimes inadequate at the moment for what ought to be done immediately. Whoever ignores the social and economic prerequisites gets entangled in illusions and is ultimately disappointed. There is nothing wrong with courage to take risks, but the chance of being able to also solve a problem recognized as necessary must be great enough that the risk is justifiable as well.

What is positive about the above-mentioned contradiction is: It represents a challenge and an impellent, and awakens new needs and hopes. The program documents of the party as well formulate goals which are to be striven for over the long range, which are not immediately attainable but have a stimulating effect.

Question: Is there a criterion for what is possible at the moment?

Prof Hofmann: A strategic goal is properly indicated if with the greatest of efforts the necessary is still attained in each case from what is at most possible. But the goal must not be set too high. Only if the "crossbar" is placed at an optimal height is it worth while to dare the "jump," only then can one improve by exerting the utmost effort. On the other hand, satisfaction with what has been achieved must not be greater than the constant pressing for the new, for greater speed, for progress. We must never forget that we are living in a time of fierce class struggle. If there were only socialism, we could pick our own tempo. But so long as imperialism exists, in the last analysis it is a question of to be or not to be.

Question: Who works out strategies at the Academy?

Prof Hofmann: Analytic-prognostic work must be a component of all research, and strategic work must be the task of scientific-leadership bodies at every level. Thus a scientist always has responsibility for both things. Thus he helps to determine strategies as well.

In the last analysis, devising strategies is not the business of an individual, especially since the problems which are of importance from a strategic point of view are becoming more and more complex and complicated, are more and more coupled with socioeconomic and other conditions. Today, even a certain scientific discipline often cannot make any confident statements without relying on the knowledge of other branches of science.

On the other hand, for the solution of a problem there are usually also several possible strategic variants, both in the method of the approach and also in terms of the so-called time axis. The formation of strategy is not a solitary act. Through new findings we always arrive at new insights. Thus it would be senseless to ask whether at a given moment we have at our disposal a perfected scientific strategy which is unconditionally acceptable for a long period of time. The general course to take in research must be continually deliberated on--something which, of course, again must not mean that a strategy can be changed, let alone discarded, arbitrarily often. That would lead to chaos.

At the Academy of Sciences of the GDR there are almost 100 scientific councils, in particular for basic scientific disciplines, for research groups, and for primary research directions. The colleges and universities as well as industry and other sectors are also represented in these. In such councils opinions encounter one another, proposals are examined, and recommendations are worked out, which then the Presidium, for example, endorses and with that establishes as binding.

Question: How do you assess the previous experiences of the Academy in the formation of strategy?

Prof Hofmann: Always whenever it has been a question of the preparation of national economic plans and also of directives of the party congresses, our thoughts about strategy have been sought and taken into account. It is a nice feeling to know that in socialism the scientist is always invited to help in the decision-making process. In this there is a manifestation of that unity of mind and might about which Lenin said that no forces, however sinister, can stand up to it.

In 1974 the Academy together with the college system drew up the plan for the long-range development of basic natural-sciences, mathematics, and engineering research up to 1990. At present we are in the process of extending this plan up to the year 2000, of determining more precisely the main directions of research, and of better apportioning the work.

Another example: More than 10 years ago the Academy had already recognized the great importance for research of our own scientific instrument manufacturing. Accordingly in this sector we have doubled within roughly every 5 years the volume of output and also the quality of the products.

Naturally our forecasts, conceptions, and strategies come into being always in cooperation with the State Planning Commission, the Ministry for Science and Technology, with ministries in specific fields, combines, and other institutions, and not least also with the friendly academies of the

socialist countries. To tell the truth--occasionally we have been better in thinking through what could be expected in science and what could be important for our society than we have been in converting our thoughts into practice.

Question: What revolutionary breakthroughs--to remain in the language of classical military strategy--are looming for the near future in connection with the main directions of basic research?

It is nearly impossible to name something precisely which does not yet exist at all. Nevertheless often there is a great deal brewing--as the saying goes. It is just simpler here to mention certain fields in which something is in the offing, such as, for example, biotechnology inclusive of genetic engineering, nuclear energetics, robotics, and so forth. In mechanics, a development is beginning similar to what has happened in electronics, where the miniaturization of electronic components has finally led to microelectronics. There is already talk of a micromechanics--that is, of the production of mechanical components according to principles of microelectronics as well as with the aid of similar and also new basic technologies. Quite soon we will be able to house in a matchbox the "insides" of scientific instruments which at present are still the size of a writing table.

Electronics and computer science have launched a true breakthrough with the transition from mechanization to automation. Incidentally, this is making itself felt not only in production and administration, but also in service fields such as public health, trade, and provisioning, indeed even in the household. Added to this is the fact that a wide variety of computers are helping the person to be creative and are freeing him from routine work. Steam engines and electric motors enlarged his physical powers, and now robots and computers are increasing his intellectual scope.

Whoever masters this process correctly and above all speedily has decisive advantages. Socialism has the best prerequisites for doing this.

Question: At present our knowledge is doubling every 8 years, and the span of time between a discovery and the beginning of its effective use in practice is becoming shorter and shorter. Will this trend continue? If so, how will it be taken into account?

Prof Hofmann: Generally speaking this trend is continuing, although of course one can also give examples which demonstrate the opposite. Thus, actually the principle of nuclear fusion has been known about for 50 years already, yet it is not likely that it will be mastered technically and economically before the year 2020. I find it impressive how the laboratory and the manufacturing plant are becoming increasingly similar in their outward appearance. Frequently, research and development, prototype production and large-scale manufacturing no longer proceed one after another, but overlap. That is also objectively necessary, because at present the renovation rate for products already comes to about 30 percent annually in the industrially leading countries.

Question: By the turn of the century, the level of technological production will have risen by a factor of two or three times, and mankind's state of knowledge will have been elevated threefold to fourfold. What is to be done strategically so those just beginning school today will be able to measure up to this pace of development someday?

Prof Hofmann: Even now, the training given in many occupations no longer suffices for one's entire life. And it is estimated that at the 50th anniversary of the GDR in 1999, in more than half of all the occupations which will exist then it will be necessary for the workers to requalify themselves several times over. Even occupations with strong traditions are changing their character, are developing for themselves opportunities from modern technology and organization. Therefore it is high time to adhere to this precept right today. The young people especially must be introduced as soon as possible to the newest technology, but the teachers as well must constantly learn more. Let us remember that in such key technologies as microelectronics, nuclear engineering, robotics, and automation, only a fraction of the conceivable ranges of application have been developed. For example, today the number of possible applications for microprocessors is already estimated at more than 100,000. Even in the technically highly developed countries, only about 5 percent of these have been implemented!

We are faced with the task of stating with increasing accuracy of aim when and where workers can be set free for other work through automation. This then allows us to decide in a timely way in what direction workers must be retrained, further educated, or--what is even more important--given initial training.

Question: As a relatively small country, the GDR cannot successfully battle on all fronts of research. How is it working together with its socialist alliance partners?

Prof Hofmann: Of the roughly 5 million scientists and more than 10 million other people who are active today in research and development in the world, every fourth one is working in the Soviet Union, which as is known is our closest ally. Compared to this, the share held by the GDR amounting to just under 2 percent in the research potential of mankind looks like a modest share. On the other hand, it is also considerable once more when one reflects that the GDR population makes up only 0.4 percent of the world's population.

Nevertheless, we can engage in research, development, and production only in selected fields. Of course, basic directions which govern pace and performance such as microelectronics, automation, or biotechnology cannot simply be ignored. Therefore the division of labor with other fraternal countries is done in each case within the framework of one of these major research fields. Thus in scientific instrument manufacture and in the production of microelectronic components, the GDR has concentrated on quite definite types.

At present the academies of sciences of the CEMA member countries are in the process of setting up a joint research program for information

processing which will extend into the next century. The plan is to establish base laboratories in various countries. Thus the GDR Academy of Sciences intends to build one for image processing. With that, the splendid achievements will be taken into account which our Central Institute for Cybernetics and Information Processes has performed in this field jointly with the Robotron Combine.

Question: From where does your confidence come that despite an imperialist arms buildup we will successfully continue our course--including that of a strategy of science?

Prof Hofmann: If in May of next year we can look back on 40 years of peace in Europe, we will owe that to the existence and the strength of socialism, which has prevented the reactionary element from starting a new unprovoked war. Thus, historical developments give us the right to be optimistic that we in the alliance, along with the forces of reason in the world which are becoming increasingly stronger, will safeguard the peace in the future as well. Developments in the 35 years of the GDR have proved: We have the power to make the life of our citizens increasingly pleasant and rewarding and also to protect our nation. Our science does not serve any other purpose.

Statistical Information

Scientific Potential of the GDR:

200,000 persons employed in research and development.

80 percent of this potential is concentrated in industry, civil engineering, agriculture, and other branches of production, with more than 150 combines having two thirds of the production capacity and three fourths of the research and development capacity.

20 percent of the potential is found in the Academy, the universities and colleges, and in other scientific institutions.

4.5 percent of the national income of the GDR is used for science and technology.

The Potential at the Academy:

Full members: 141
Corresponding members: 87
Nonresident members: 140
Contributors: about 22,000

Research fields: 6

Classes: 10

Scientific councils: almost 100

Research institutions: 53

90 percent of the mathematics-natural sciences and technical potential is concentrated on basic directions of scientific-technical progress.

These include:

Microelectronics,
flexible automation,
the use of computers in information-processing operations,
nuclear energy,
increased processing of coal and other raw materials as well as industrial materials,
modern biotechnologies.

Quotations:

"Pride in our results up to now in the development of microelectronics, robotics, data processing, and other ultramodern technology is entirely justified. But we do not ignore what decisive demands are still facing us in this field. It was with very good reason that a linking of the advantages of socialism with the possibilities of the scientific-technical revolution has been placed at the head of the economic strategy of our party. The pace of developments internationally is fast and is increasing even more." Erich Honecker: "Our Republic--State of Peace and Socialism" in EINHEIT, 9-10/84.

"Science questions long-standing practices, it replaces the old by the new, the good by the better--an act of 'creative destruction,' in order to ensure growth in economic output....Our economic strategy unites need-oriented objectives with the main lines of scientific-technical progress over the coming years. Thus the focal points of economic strategy make up the initial decisive determinant of the strategy of science." Academy president Prof Dr Werner Scheler in EINHEIT, 12/83.

"General philosophizing about the purpose and utility of the scientific-technical revolution is not helpful to us. Society quite properly expects from us examinable statements about long-range strategies for our country....Our work should help bring it about that when a technology is needed, it will be available." Prof Dr Karl Friedrich Alexander, director of the Central Institute for Electron Physics, in SPECTRUM, 1/83.

12114

CSO: 2302/29

GERMAN DEMOCRATIC REPUBLIC

NEW CONCEPTS FOR INDUSTRIAL ROBOTS OUTLINED

East Berlin FERTIGUNGSTECHNIK UND BETRIEB in German Vol 34 No 7, 1984
pp 392-396

[Article by H. Scheibner, Engineer, GDR Chamber of Technology, Research Center for Machine Tool Construction, Karl-Marx-Stadt VEB 'Fritz Heckart' Machine Tool Combine]

[Text] 0. Introduction

Automation in small and medium production in machine construction requires solutions which meet the requirement for great flexibility and high productivity (1). This increasingly requires the expansion of CNC machine tools with equipment for automating the flow of information and materials.

With the introduction of numerically controlled machine tools and processing centers, the working process and tool changes (in processing centers) have been largely automated. Thus, about 40 percent of the operator and monitoring functions on machine tools run automatically (2). For about 60 percent of the operating and monitoring functions, manual procedures continue to be necessary. The major portion of these manual procedures here accrues to workpiece handling, workpiece checking, as well as checking of tool fracture and wear.

Automating these operating and monitoring functions is absolutely necessary to decrease further the need of operators to run the machine tools. Modern CNC engineering makes it possible to perform these functions automatically. The advantages which accrue from automation of these functions are primarily:

- reduction of auxiliary times
- better machine workload
- relieving the machine operator from monotonous and physically heavy work
- increasing output while reducing operational and monitoring work.

New production concepts have recently formed with the automation of workpiece handling, work monitoring, and the checking of tool fracture and wear. Depending on the technological requirements, these production concepts comprise different integration and automation stages.

A distinction is made with respect to integration and automation stages, among the following three production concepts:

- technological unit
- production cells
- production system with robots (or also robot production system).

These production concepts are important components for automation, relative to the workstation and to the process, in parts production.

1. Definition of the Production Concept

A definition of production concept is possible according to functional and structural perspectives.

The decisive component for delimiting the production concept is automatic workpiece handling. With the development and utilization of industrial robots for automatic workpiece handling, the technological unit has emerged as the first production concept. Here, the machine was subsequently equipped for workpiece handling by means of industrial robots. This integration yields the automation level for the technological unit (TE) shown in Figure 1. Compared to this, production cells have a higher degree of integration and automation.

In Figure 1, all operating and monitoring functions at machine workstations run automatically in the case of production cells. TEs and production cells (FZs) have hitherto been developed and used to process both rotation-symmetric and prismatic workpieces.

With production cells having automatic workpiece handling for prismatic workpieces, one distinguishes the following three variants.

Variant A:

Indirect automatic workpiece handling with pallet-changing equipment and pallet storage
(manual loading of the palette or clamping device and automatic loading of the pallet into the work space).

Variant B:

Direct automatic workpiece handling with industrial robots in the working space of the machines

Variant C:

Combined automatic workpiece handling with industrial robots and pallet changing equipment
(automatic loading of the workpiece clamping device and automatic loading of the pallets in the working space. Combination of variants A and B)

Figure 1. Functional delimitation of automated production concepts

1	Teilfunktionen des Fertigungsablaufes	handbediente Universal-werkzeug-maschine 2	NC/CNC Werkzeug-maschine 3	Technolo-gische Einheit 4	Fertigungs-zelle 5
6	Werkstücktransport	○	○	○	○
7	Werkstückspeichern	○	○	●	●
8	Werkstückhandhaben (eingegeben, spannen)	○	○	●	●
9	Bearbeiten	○	●	●	●
10	Werkzeug-wechsel	○	●	●	●
11	Werkstückkontrolle	○	○	○	●
12	Werkzeugkontrolle	○	○	○	●
13	Werkstückhandhaben (entspannen, entnehmen)	○	○	●	●
14	Werkstückspeichern	○	○	●	●
15	Werkstücktransport	○	○	○	○
				○ manuelle Teilfunktionen 16	
				● automatisierte Teilfunktionen 17	

- 1 parts production of the production sequence
- 2 manually operated universal machine tool
- 3 NC/CNC machine tool
- 4 engineering unit
- 5 production cell
- 6 workpiece transport
- 7 workpiece storage
- 8 workpiece handling (input, clamping)
- 9 processing
- 10 tool change
- 11 workpiece checking
- 12 tool checking
- 13 workpiece handling (unclamping, withdrawal)
- 14 workpiece storage
- 15 workpiece transport
- 16 manual component function
- 17 automated component function

Figure 2: Structural delimitation of automated production concept

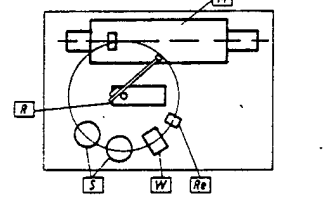
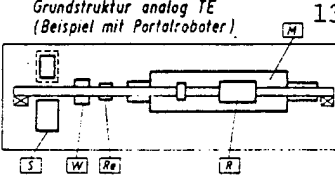
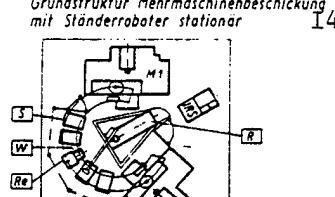
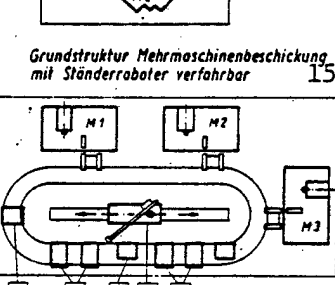
Fertigungskonzept 1	Grundstruktur 2	Hauptkomponenten 3	
<p>NC / CNC - Werkzeugmaschine 4</p>		<p>M : Werkzeugmaschine M1...Mn</p>	16
<p>5 Technologische Einheit (TE) (Einmaschinenbesetzung) 6</p>		<p>M : eine Werkzeugmaschine R : Ständerroboter, maschinen-integrierter Roboter, Portalroboter S : Rundtactspeicher, horizontaler und vertikaler Ketten-speicher, Flachpaletten-speicher W : Werkstückwendeinrichtung Re : Reinigungsstation</p>	17 18 19 20 21
<p>7 Fertigungszelle (FC) (Einmaschinenbesetzung) 8 mit maschineninterner Pro- zeß- und Werkzeugüber- wachung 9</p>	<p>Grundstruktur analog TE (Beispiel mit Portalroboter) 13</p> 	<p>M : eine Werkzeugmaschine R : Ständerroboter, maschinen-integrierter Roboter, Portalroboter S : Rundtactspeicher, horizontaler und vertikaler Ketten-speicher (Palettentakt-einrichtung) W : analog TE Re : analog TE</p>	22 23 24 25
<p>10 Roboterfertigungssystem Variante A (Mehrmaschinenbesetzung mit einem Roboter) 11 für gleiche oder unter- schiedliche Arbeitsver- fahren 12</p>	<p>Grundstruktur Mehrmaschinenbesetzung mit Ständerroboter stationär 14</p>  <p>Grundstruktur Mehrmaschinenbesetzung mit Ständerroboter verfahrbar 15</p> 	<p>M : ≙ 2 Werkzeugmaschinen gleicher oder unter- schiedlicher Arbeits- verfahren R : Ständerroboter stationär und verfahrbar, Portalroboter S : analog TE W : analog TE Re : analog TE</p>	26 27 28

Key: Figure 2

- 1 production concept
- 2 basic structure
- 3 main components
- 4 NC/CNC machine tool
- 5 engineering unit (TE)
- 6 single machine loading
- 7 production cell (FZ)
- 8 single machine loading
- 9 with machine-internal process and tool monitoring
- 10 robot production system, variant A
- 11 multi-machine loading with one robot
- 12 for similar or different working operations
- 13 basic structure analogous to the TE (example: with mobile robot)
- 14 basic structure, multi-machine loading with stationary stand-robot
- 15 basic structure, multi-machine loading with mobile stand-robot
- 16 machine tool
- 17 one machine tool
- 18 stand robot, machine-integrated robot, mobile robot
- 19 revolving storage unit, horizontal and vertical chain storage, flat pallet storage
- 20 workpiece turning device
- 21 cleaning station
- 22 one machine tool
- 23 stand-robot, machine-integrated robot, mobile robot
- 24 revolving storage, horizontal and vertical chain storage unit (pallet cycling device)
- 25 analogous to TE
- 26 equal or greater than two machine tools with similar or different working processes
- 27 stand-robot, stationary and mobile, portal robot
- 28 analogous to TE

The structural limitation of automated production concepts is shown in Figure 2. Depending on the construction forms of industrial robots, one obtains the basic structures indicated in the figure. From this it becomes clear that TEs and FZs are intended for single-machine loading.

These structures are essentially distinguished by

- the level of automation and integration
- construction forms of the industrial robots
- type and scope of workpiece storage and further peripheral equipment

A new production concept, the robot production system, has crystallized out for multi-machine loading with industrial robots. Robot production systems are implemented with processing machines having the same or different working procedures. Robot production systems with an industrial robot or with several industrial robots can be implemented here. Furthermore, it is also possible to assign conventional machines to robot production systems. The level of automation of robot production systems corresponds to that of the TEs and FZs.

To implement automated production concepts, loading robots of the following construction forms can be utilized:

- stand-robots, stationary and movable
- machine-integrated robots
- portal robots.

The IR construction forms for the production concepts must be chosen according to criteria such as:

- loading level
- flexibility of the arrangement possibilities of the individual equipment
- workstation area utilization and requirement
- handling functions that can be implemented
- possibility of inclusion into existing production systems including the TUL (transport, loading, storage) process
- expenditure.

2. Examples of Applying Automated Production Concepts

2.1 Rotational Processing

Engineering Units:

For processing rotational-symmetric workpieces, hitherto TEs have been mainly developed and used with lathes and the industrial robots IR 2S2 and WMR 01.

The industrial robot IR 2S2 is a stand-robot in a C-frame design with electro-hydraulic drive and with a maximum of five degrees of freedom (C, Z, X, A, Y).

The industrial robot IR 2S2 is used in TEs in various expansion stages, without position-controlled axes and with one to three position-controlled axes, for handling workpieces up to 40 kg, either with an IRS 2000 control or with an IRS 600 microprocessor control.

The industrial robot WMR 01 is an hydraulic stand-robot with position-controlled axes.

Figure 3: Engineering unit with IR 2S2 for processing shaft parts.

Figure 4: Engineering unit with IR 2S2 for processing chucked, turned parts.

In TEs with the IR 2S2 and WMR 01, single- and multi-level revolving storage units are used for the workpieces. The universal gripper system with simplified main subassemblies was developed to grip the shaft and flange parts. A single gripper was used for shaft parts and a double gripper for chuck parts.

Figure 3 shows a TE with the IR 2S2 for shaft processing. Shaft-shaped parts with a workpiece diameter of 14 to 125 mm and a length of 60 to 700 mm can be processed on this TE. By using a multi-level revolving storage unit, and with an appropriate lot size, a low-service time of two to three hours can be achieved. Change-over times for industrial robots and workpiece storage units amount to about 20 minutes.

By means of this TE and with appropriate matching, productivity can be increased.

This TE is already being used in several machine construction enterprises of the GDR.

An engineering unit with the IR 2S2 industrial robot and with three multi-level revolving storage units for processing chucked, turned parts is shown in Figure 4. By means of this TE, chucked, turned parts with a workpiece diameter of 30 to 100 mm and a length greater than 10 mm are processed. Rod sections, shaped parts, and cast parts can be processed completely by this TE (first and second side). By using three workpiece storage units, 108 parts can be stored.

With an average processing time of six minutes, one thus obtains a time without changeover amounting to about one shift. A special problem for chucked, turned parts is the proper insertion of parts into storage by pressing the parts into the die truck. For this procedure, three technical variants are available:

- pressing in with the gripper
- pressing in with a device integrated into the tool carrier
- pressing in through a separate swivel arm or a sliding device.

Previous experience has shown that the best results can be obtained with the second variant, as regards the attainable workpiece quality.

In particular, the following quality results have been reached up to now:

Variants 1 and 3: IT 8 (IT 7) with a face-runout ± 0.05 mm

Variant 2: IT 7 (IT 6) with a face-runout ± 0.02 mm

By using a double gripper, up to 30 seconds per part are saved compared to the single gripper.

The economical results are of the same order as in the case of the shaft unit.

TEs with a large number of different machines and systems, for example lathes of the types DF2, DS2, DFS 400, DF 315, DRT/s, DAMF, special machines for milling, drilling, and thread processing, inductive hardening, and the like have recently been developed and used in conjunction with the industrial robot IR 2S2.

A TE with industrial robot WMR 01, a lathe, and a single-level revolving storage unit, can be seen in Figure 6.

Figure 6. Production cell with IR 2P2 for processing chucked, turned parts

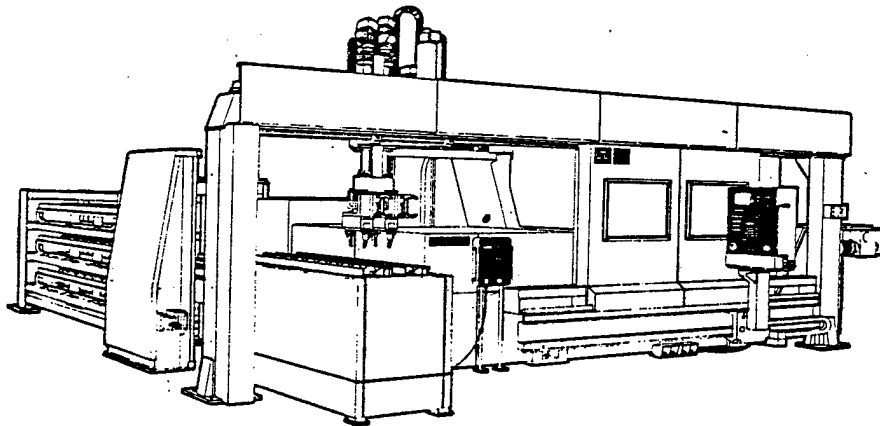

Workpieces can be processed with a range of diameters from 30 to 200 mm and lengths from 200 mm. The WMR 01 is equipped with a single gripper. Since this industrial robot does not have a position-controlled Z-axis, it is not possible to process multi-level storage units. The storage units shown in Figure 5 can accept about 20 workpieces.

Figure 5. Engineering unit with the WMR 01 for processing chucked turned parts.

As regards machine matching and safety, the design of the TE is similar to the TE for chucked turned parts with the IR 2S2.

Because of the non-position-controlled axes, the change-over time is longer as compared to the IR 2S2. Because of the use of a single gripper, the handling time is longer too. But this is balanced by the lower costs of the WMR 01.

When using the WMR 01, productivity can be increased up to 30 percent.

The WMR 01 is currently being used with a large number of lathes (DS-2-NC, DF 2-NC, SPT16, DFS 400) and also milling machines (FKrSRS) (3,4).

The turning production cell shown in Figure 4 was developed for low-service small and medium production of both flange-shaped and shaft-shaped parts up to 60 kg weight.

The workpieces are handled by portal robots with four degrees of freedom (X, Z, C, D), two of these with positional control (X,Z). This achieves a line action. The gripper for unfinished parts and finished parts is designed in such a way that it can swing into the working space of the DFS 2/2 lathe.

Flange parts up to 250 mm diameter and shaft parts up to 800 mm length with a diameter of 120 mm can be handled.

The production cell is controlled with a CNC - H655 control in combination with the IRS 651 robot control.

The wear condition of the tools is analyzed at the same time, and tool fractures are detected. The wear condition of the tools and tool fractures are determined through body-borne sound. Furthermore, a 3-D measuring sensor is available for checking the tools. This is disposed axis-parallel to the rotary spindle.

The workpieces can be checked either machine-internally with a measurement sensor integrated into the tool storage unit, or else machine-externally in a measurement station that is loaded by the portal robot. The workpieces are stored in a cassette storage unit on portable flat pallets. One flat pallet of size 0 (800 mm x 1200 mm) is always pushed out of the storage unit in each cycle, corresponding to the spacing of parts on the pallet.

This production cell can achieve at least one low-service operation of one shift with a productivity increase up to 100 percent.

Robot Production Systems

Figure 7 shows a robot production system with the IR 2S2 at two DF 2-CNC 600 lathes. Workpieces in a clamping range from 60 to 200 mm diameter can be accepted by this system. Sixty workpieces are stored in the workpiece storage unit.

Figure 7: Robot production system with the IR 2S2 for processing chucked turned parts.

A robot production system was implemented with a movable IR 2S2 of the VEB Machine Tool Combine "Fritz Heckert" (see also *Fertigungstechnik und Betrieb* No. 3, 1984, p. 184). The IR 2S1 - movable loads two machine tools, two lathes, and one milling and drilling machine. This system is further equipped with six revolving storage units with two measurement stations.

Compared to the IR 2S2, the IR 2S1 has an open stand and can be designed stationary or movable on rails up to 10 meters. The axis designs and parameters are identical with those of the IR 2S2.

By means of this robot production system, it is possible to achieve essentially complete processing of the parts for the selected parts assortment (short rotationally symmetric parts, 10 kg weight, diameter 60 to 200 mm, length greater than 10 mm) (5).

The unfinished parts are manually placed on a storage unit. Without any intermediate transport and without any intermediate storage, they are rough turned and finish turned, milled, drilled, and checked. After processing, the parts are conducted directly to assembly, or, if necessary, to final processing.

Processing times of 30 minutes are required to process the parts effectively.

An automatic clamping and cleaning device, combined with an external alignment device, was developed for the milling machine.

A ball-sprung press-on device was created for high-quality processing on the lathes. Parts of the required quality can thus be processed.

The overall system was divided into two subsystems for engineering reasons. These subsystems are interlinked for safety so that one machine can be loaded if any machine breaks down or the machines can alternately also be converted during operation.

The economical results of the robot production system are achieved:

- significant reduction of run-through times
- productivity increased by 200 percent
- elimination of 4.5 jobs and
- a saving of work time of about 7000 hours.

However, a major portion of the results is due to the basic change of the technology and to the application of group technology.

It thus becomes clear that above average increases are achieved by using such robot production systems in parts production while implementing the most complete finishing processing without intermediate storage and intermediate transport. This example clarifies where the reserves and perspectives lie in connection with robot deployment.

2.2 Prism Processing

Engineering Units

The processing centers CFKrW250NC, CFKrS250NC and FKrSRS250NC or CNC are mainly used to process prismatic parts.

Figure 8 shows an engineering unit with the IR 2S2 and the CFKrW250CNC (variant B).

Small and medium prismatic single parts with an edge length ≤ 400 mm can be processed on this TE. Compared to the loading of lathes, the prism loading imposes much more stringent requirements as regards

- storage technology
- gripper technology
- workpiece clamping and monitoring technology, as well as
- quality control (6)

Basic investigations concerning the engineering process are especially necessary in prism loading. Such engineering perspectives as multi-unit clamping, high process integration in one mounting process, process intensification, process substitution, and group technology play an essential role here. The number of mountings was reduced from five to two for the parts assortment that was to be processed in the TE shown in Figure 8. Only in this way did automatic workpiece handling become possible. Stackable flat metal pallets were used for storage units, which could be restacked by the robot itself. Single grippers were chosen as the grippers. So that the loading time with the single grippers does not increase significantly, an intermediate depot before the machine was created. This TE achieves a productivity increase above 100 percent.

Production Cells

Production cells of variant A have hitherto been developed for automatically loading workpieces with prismatic parts. These production cells are characterized by pallet changing devices (manipulators) and pallet storage units. The workpieces and tools are checked with 3-D measurement sensors, calipers, or cameras, all operating automatically. Figure 9 shows a production cell.

Tool changes are also automated in these production cells.

The following are important components for the pallet changing technique: The pallet, the rotary changer with a vertical or horizontal axle, the palette-car, the double-arm manipulator with ring storage, the single-arm manipulator with ring storage, and the pallet pool. By means of this technology, it is possible to achieve low-service operation up to one shift. There are production cells with the basic machines CFKr250, FC400K, CW/S500, CW/S800 and Sabomatic 630.

Figure 8: Engineering units - CFKrW250CNC processing center with IR 2S2 industrial robot

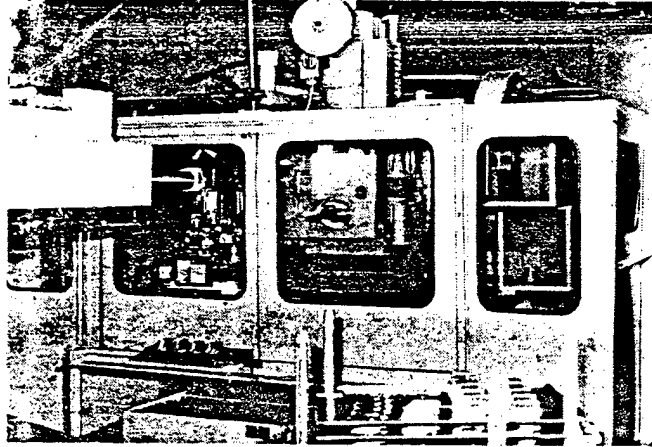
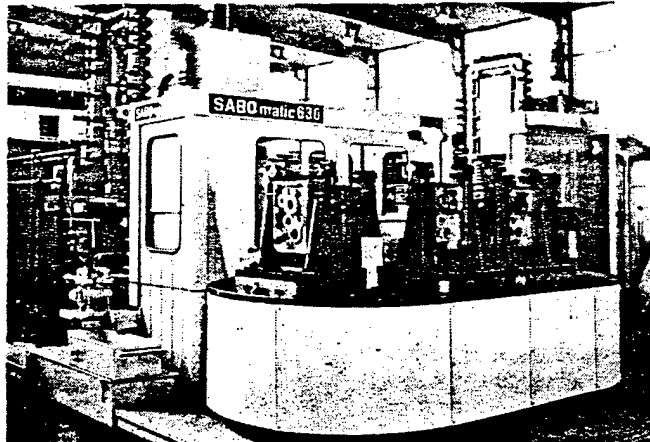

Figure 9: FCW630 production cell



Robot Production System

A robot production system is deployed with the IR 2S2 in combination with two CFKrW250CNC.

To implement multi-machine loading, it was necessary to extend the flight circle of the IR 2S2 by about 500 mm. Compared to single-machine loading, multiple-machine loading demonstrably achieved a further increase of the economic result.

For the robot production system, one calculated

- an elimination of five jobs and
- a productivity increase by 300 percent.

3. Summary

This paper presented new production concepts with industrial robots.

These production concepts create important presuppositions for automation relating to the workplace. At the same time, these concepts are important components for flexible production systems.

References

- (1) Steinhilper, R.: Flexible production cells. Swiss Machine Market, Goldach (1983) 22, p. 42-47.
- (2) Speck, M.; Paessler, E.; Uhlmann, W.; et al.: Developmental trends and experience in metal processing in small and medium production. Lecture. IKM 1978, Leipzig.
- (3) Pabst, W.: Type project for the TE-WMR01 and DS2-CNC. VEB Engineering Office of the VEB Machine Tool Combine "Fritz Heckert", 1983.
- (4) Richter, J., Winter, P.: Type project for the TE-WMR01 and DF2-CNC. VEB Wema Union Karl Marx Stadt, 1983.
- (5) Scheibner, H.; Oehme, D.: et al.: Research report concerning the robot complex with the IR2S1-mobile for loading lathes. FZW*1983.
- (6) Rabe, W.; Scheibner, H.: Research report on the TE and robot complex with the IR 2S2 for loading processing centers. FZW, 1983.

*FZW = Research Center for Machine Tool Construction Karl Marx Stadt.

8348

CSO: 2302/20

MACHINE TOOLS AT 1984 LEIPZIG SPRING FAIR

East Berlin FERTIGUNGSTECHNIK UND BETRIEB in German Vol 34 No 7, 1984 pp 432-439

[Text] For about 9000 exhibitors, as well as for visitors from about 100 countries, the Leipzig 1984 Spring Fair again proved to be the traditional center of commerce and all around information.

Under its established motto, "For open international trade and technical progress," the Fair of the German Democratic Republic could act as a site of lively international commercial activity, and as a forum for performance comparisons and for the exchange of scientific-technical information. Its representative international participation expresses the world-wide interest in mutually useful commercial and economic relations.

Through their products, the combines and export enterprises of the GDR document their stable development.

The vendors cover the areas of metallurgy, construction of heavy machinery and systems, with exhibitors from 27 countries, machine tools and other tools with exhibitors from 18 countries, agricultural and foodstuff engineering, packing machinery with exhibitors from 16 countries, as well as electrical, automation, and information engineering with exhibitors from 26 countries. With their 22 engineering branches, these areas are of outstanding significance.

The production of microelectronic components and technological equipment is increasing above average in the GDR. This is creating the preconditions for a broad and rapid development and application of microelectronics. Thus, the increased performance capability of the microelectronics industry expresses itself, for example, in its supply of patents, licenses, know-how, and other scientific-technical results.

The main producers of machine tools in the GDR, together with their exhibits, were already presented in Issue No. 2 of "Fertigungstechnik und Betrieb". These include:

VEB Machine Tool Combine "7 October" Berlin
VEB Machine Tool Combine "Fritz Heckert" Karl Marx Stadt
VEB Combine Shaping Technology "Herbert Warnke" Erfurt and
VEB Tool Combine Schmalkalden.

This year, for the first time, the program was supplemented by selected products from the assortment of exhibits from the Ministerial area of heavy machinery and systems construction and the VEB Combine Electrical Machine Construction.

In these "gleanings", we wish to make you, dear reader, acquainted with some interesting exhibits, especially from foreign exhibitors.

We looked around in the exhibition halls 7, 11, and 20.

GDR

Microcomputer-supported Software Solutions

Newly developed workstations for making production-managing processes more efficient were exhibited, especially in design, planning, and engineering. In this area, the VEB Combine Robotron is demonstrating the use of special basic computers and office computers for job-related tasks.

1. Workstation for Design and Engineering (AKT) robotron A 6454

The AKT robotron A6454 (Figure 1) is a CAD/CAM system for computer-supported design and engineering preparation for production. Its main use areas are:

- computer-supported production of drawings
- the planning of machinery and systems
- the design of variants
- the programming of numerically-controlled machine tools
- the calculation of individual parts.

2. Controls

2.1 CNC 600-3 Control

The CNC 600-3 control is a further development of the CNC 600 controls (VEB Numerik Karl Marx).

Advantages:

- higher efficiency for the deployment of machine tools in the engineering processes of milling/drilling
- accompaniment and evaluation of a word position with integrated tool change with free place allocation
- selection of axes when resetting all five axes
- shorter set transfer times during programmed wrapping motion
- input of signed lock compensation values
- increase of the PMC storage
- five axes are included in circular and helical interpolation.

[Figs 1-3 not reproduced]

2.2 Industrial Robot Control IRS 650

The IRS 650 (VEB Numerik Karl Marx) can be used for articulated robots with electrical drives. It permits the simultaneous activation of six position-controlled axes in track operation.

Advantages:

- suited for handling technology and engineering problems
- programmed according to the indirect teach-in method, thus rapid adaptation to the production process
- very handy operating panel and thus programming is possible from a technically favorable site
- a high degree of reliability and flexibility
- variants can be planned and thus efficient use is possible for particular applications
- a diagnostic system simplifies start-up, maintenance, and service.

2.3 Memory-Programmable Control System PC 600

The PC 600 exists in the variants PC 601, PC 602 and PC 603.

Application:

- control of machine tools, special machines, and plastic processing machines, large-part processing machines, cycle lanes, polygraphic machines, etc.
- control signals are furnished (are generated as a result of an algorithmic linkage of input signals)

Advantages:

- increase of use value to 1.627
- implementation of analog values and interrupt inputs.

2.4 Two-Computer Control Based on a CNC-H600 Microcomputer System

This is offered in three variants:

- CNC-H642-1 (Point-line-control for drilling and milling machines)
- CNC-H645-1 (Track control for lathes)
- CNC-H646-1 (Track control for milling machines and processing centers)

Application:

- for universal and single-purpose machine tools (in small and large-scale production)

Advantages:

- no tool adjustment devices and organizational equipment (very costly)
- simple programming (through the integration of elements of machine programming in the CNC)
- direct workpiece programming
- convenient subprogram technique.

3. Universal Length Measuring Device ULM 01-600 C

The ULM 01-600 C from the VEB Carl Zeiss JENA is a universal single-coordinate measuring unit.

Technical Data

Measuring equipment	Abbe measuring element IDL 01
measurement range	100 mm
graduations	0.1 μ m
measurement power	0; 1.5; 2.5 N
length (for max measurement length of 600 mm)	1250 mm
depth	380 mm
height	450 mm
basic unit	100 mm

The universal length measuring unit was distinguished at the 1984 Leipzig Spring Fair by a gold medal.

USSR

1. Spindle Press with Curved Stator Drive

The Universal Press F1762A (Figure 2) (exporter: Stankoimport, Moscow) is suited for hot and cold punching, bending, sizing, and stamping, and for the preforating of workpieces of iron and non-ferrous metals.

Application:

- machine construction
- household and jewelry industry
- automobile plants, etc.

Technical Data

tappet excursion, max	200 mm
number of tappet strokes per min	36
tappet length	350 mm
distance between table and tappet	190 mm
dimensions of the table	400 mm x 450 mm
weight of the press	3600 kg

2. Vertical Semiautomatic Gearing Machine for Spur Wheels

This semiautomatic machine of type 5A140 (exporter: Stankoimport, Moscow) (Figure 3) is intended to cut spur wheels with inside and outside teeth.

Application:

- roughing work
- semifinishing work
- finishing work

The gear wheels are automatically processed in a generating process.

This semiautomatic machine was distinguished by a gold medal at the 1984 Leipzig Spring Fair.

Technical Data

- indexing diameter of the gear wheel being processed with inside and outside teeth, max	500 mm
- module of the gear wheels being cut	8
table diameter	560 mm
largest excursion of the tool spindle weight	125 mm
outside dimensions of the machine	7500 kg
rpm of the main drive electric motor	2230 mm x 1250 mm
	750 rpm, 1000 rpm, 1500 rpm

3. Automatic Longitudinal Lathe

The 11T16A and 11T16B automatic longitudinal lathes (Figure 4) were offered by the exporter Stankoimport, Moscow.

Application:

- watch and fine device construction industry (in mass production)
- parts of complicated shape (rotational objects up to 16 mm diameter, 80 mm length)

Advantages:

- simple maintenance by automatic periodic central lubrication
- design with six supports

Technical Data

Maximum rod length	
diameter	16 mm
length	3000 mm
rod advance with	
disk curve max	80 mm
bell curve	140 mm
drilling diameter min	1 mm
drilling spindle path max	40...50 mm
number of spindle revolutions	24
spindle rpm	450...6300 rpm
number of curved shaft revolutions	
per spindle revolution	29...38
rpm of the curved shaft	0.049...20.4 rpm
weight	1200 kg

4. High Precision Horizontal Drilling, Milling, and Boring Machine

The machine of type 2204BMF4 (Figure 5) was offered by the exporter Stankoimport, Moscow. It is intended for the complex processing of medium-large workpieces having four sides (without resetting).

Application:

- semifinish and finish milling
- drilling
- countersinking
- reaming

The machine is controlled by the universal NC system "Rasmer 2M-1300".

Technical Data

surface of the worktable	400 mm x 300 mm
maximum coordinate adjustment of the table and the spindle box	500 mm
working feeds	1...4000 rpm
weight of the processed workpiece	300 kg
feed force max	9800 N
weight of the machine	5000 kg

5. Vertical Drilling and Milling Machine with NC Device Type 21104H7F4
(Figures 6 and 7)

The machine from the exporter Stankoimport, Moscow is intended to process workpieces of complicated shape. The processes of drilling, milling, countersinking, and reaming are combined in one machine.

Technical Data

surface of the working table	630 mm x 400 mm
weight of the workpiece when processing on the table	630 mm
when processing on the removable plate	350 mm
weight of the machine	7950 kg
number of positions in the tool magazine	16

Rumania

1. Vertical Processing Center CPV 1 (Figure 8)

This processing center (export enterprise: Masinexportimport, Bucharest) is used to process housing workpieces (drilling, reaming, milling, etc.). The cast parts are ribbed and secure the stability of the machine. The processing center has a tool magazine (drum) with a shaft, on which are situated 30 tools. Tools are changed automatically.

Technical Data

table surface	1450 mm x 930 mm
transverse stroke	1250 mm
longitudinal stroke	800 mm
vertical stroke	500 mm
main spindle boring	ISO 50
range of rpm	16...3200 rpm
range of infeed	5...2000 mm/min
weight of the workpiece, max	4000 kg

main drive motor	7 kg
length	3400 mm
width	3300 mm
height	3500 mm
weight	11000 kg

2. Hobbing Machine FD400

The hobbing machine (exporter: Masinoexportimport, Bucharest), Figure 9, was exhibited at the Leipzig Fair in addition to the FD250, FD630, FD800, FD900, and the FD1250.

Technical Data

milling diameter max	400 mm
module max	8
axial stroke	300 mm
tangential stroke	150 mm
clamping table, diameter	450 mm
table boring, diameter	100 mm, 70 mm
taper of the milling spindle	4 MK
milling cutter (diameter x length) max	160 mm, 180 mm
slant of the milling head	45°
milling cutter rpm	50...300 rpm
infeed axial	0.7...6.3 mm/revolution
infeed radial	0.05...2.0 mm/revolution
infeed tangential	0.1...4.0 mm/revolution
milling power	7.5 kW
total power	14 kW
operating voltage	3 x 380 V, 50 Hz
weight	6.4 t
dimensions	
length	2645 mm
width	1400 mm
height	2000 mm

CSSR

1. Automatic Gear Wheel Production Lane AUCO (Figures 10 and 11)

This involves a multipurpose production lane. It is composed of universal gear cutting machines which are equipped with automatic cycles and which are adapted for automatic tool change by using an industrial manipulator.

Applications:

- double wheels
- wheels with clutch processes
- wheels with outside and inside teeth

Units of the production lane

1 VKZ large capacity workpiece storage unit, manufacturer VEB WMK "7 October" Berlin, VEB Gear Cutting Machine Factory MODUL Karl Marx Stadt

2 OFA 32 A Gear wheel hobbing machine. Manufacturer TST Conglomerate Enterprise TOS Celakovice
 OHA 32 A Gear wheel generating machine. Manufacturer TST Conglomerate Enterprise TOS Celakovice
 ZRu 800x8 Gear wheel circular milling machine
 M63-21 Industrial manipulator. Manufacturer VIHORLAT Snina, Development VUKOV, Presov

This production lane was distinguished by a gold medal at the 1984 Leipzig Spring Fair.

2. Semiautomatic Lathe SPT 32 NC

This semiautomatic device (Figure 12) was manufactured by COVOSVIT Sezimovo Usti. The machine is intended to process parts of complicated shapes up to 320 mm diameter and up to 1500 mm length, as well as flange-shaped parts up to 250 mm length.

Applications:

- turning cylindrical, tapered, outside-, inside-, and flat-surfaces
- drilling and reaming
- cutting of outside and inside threads

The semiautomatic lathe SPT 32 NC is controlled by means of an NS 660 CNC control.

3. MCSK 8 NC Turning Center (Figure 13)

This turning center by TOS Hulin is a machine for several types of processing. The working cycle is automatically controlled, it has numerical track control, and the rotational tools and chisel holders are changed automatically. It is intended to process flange-shaped and disk-shaped parts up to a weight of 2500 kg. The numerical control NS-560 belongs to the standard design of the machine.

Technical Data

flat disk diameter	800 mm
diameter, max	1000 mm
workpiece height, max	720 mm
workpiece weight, max	2500 kg
power of the main drive motor	30 kW

The machine was distinguished by a gold medal at the 1984 Leipzig Spring Fair.

Bulgaria

1. MC 032 Processing Center (Figure 14)

This processing center (exporter: Machinoexport, Sofia) is used to produce workpieces of complicated shapes.

Applications:

- for drilling, reaming, and milling.

Technical data

number of axes	5
adjustment of coordinate axes, max	
X	550 mm
Y	550 mm
Z	500 mm
A	245 deg
B	360 deg
tool weight, max	10 kg
diameter and length of the tool	diameter 90 mm x 250 mm
weight	6000 kg
dimensions	3600 mm x 3200 mm x 2500 mm

The processing center was distinguished by a gold medal at the Leipzig Spring Fair.

3. Industrial Robot RB241

The RB241 (exporter: Machinoexport, Sofia), Figure 15, was intended to automate auxiliary operations, such as loading, unloading, tool change, paletting, and other functions involving machine tools.

It can service up to two machine tools.

Technical data

motions	5
control	positioning control
positioning accuracy	+ 1 mm
weight	620...750 kg

4. CP503 Lathe

The CP503 lathe (exporter: Machinoexport, Sofia), Figure 16, is equipped with the CNC control system "FANUC 3T". It guarantees that the working program is entered into the memory manually or with paper tape.

Technical data

peak height	285 mm
circumferential diameter, max	
over bed	580 mm
over the cross-slide	310 mm
turning length, max	800 mm
rpm range	180...2000 rpm
main drive power	9.5/12 kW
infeed min	1mm/min
infeed max	5000 mm/min
infeed force max (longitudinal/transverse)	6000/10000 N

Poland

Universal Lathe TUM 350 (Figure 17)

Manufacturer: Pleszewska Fabryka Obrabiarek, Pleszew

Technical data

swing-over diameter over the bed	350 mm
swing-over diameter over the support	200 mm
turning length	1000 mm
number of spindle rpms	14
rpm range of the spindle	28...2500 rpm
drive power	4 kW
machine weight	1500 kg

Industrial Robot IRb

Manufacturer: MERA-PIAB, Warsaw

This industrial robot consists of the manipulator part and its associated control box.

The manipulator is equipped with a DC disk motor, resolver, and tachodynamo.

The control system is composed of a microcomputer, memory, interface for the cassette memory and control units of the servo equipment of the robot.

Figure 20 shows the dimensions of the manipulator and the working space of the IRb. [Fig. 20 not reproduced]

Technical data	IRb-6	IRb-60
rated load (including gripper weight) in kg	6	60
length of the gripper in mm	200	400
positioning accuracy in mm	<u>+0.2</u>	<u>+0.4</u>
speeds, max		
rotation about the frame in deg/s	90	90
horizontal motion of the arm in m/s	0.75	1.0
vertical motion of the arm in m/s	1.1	1.0
inclination of the hinge in deg/s	115	90
allowable ambient temperature of the manipulator, max, in deg C	50	
of the control box, max, in deg C	0 to 40	
electrical connections, max, in kW	2	7
number of programs in the memory		4
weight of the manipulator in kg	125	750
weight of the control box	325	425

Industrial Robot PR-02

Manufacturer: MERA-PIAP, Warsaw

This industrial robot can be used for

- loading and unloading machine tools for metal cutting and shaping work
- extraction from casting and injection molding machines
- assembly of modules

The handling construct consists of the mechanically linked components (MA, MB, MD, MK).

As regards technical data of the components for the linear motion, see Table 1, and for circular motion, see Table 2.

Other parameters

working pressure range in MPa	0.5 to 0.7
rated pressure in MPa	0.6
load in N	10 to 150
weight in kg	100
dimensions in mm	1150 x 650 x 400

Table 1. Technical data of the components (linear motion)

Typ 1	Hublänge mm 2	Anzahl der Positionierungspunkte 3	Wiederholgenauigkeit mm 4	Geschwindigkeit mm/s 5	Belastbarkeit 8	
					in Richtung der Bewegungsachse 6 N	Senkrecht zur Bewegungsachse 7 N
MA 3001	5...300	2	± 0,05	300	60	80
MA 3002	5...300	2	± 0,05	500	150	200
MA 6002	5...600	2	± 0,05	500	150	150
MA 6002 M	5...600	2	± 0,05	500	150	200
MB 2003	5...200	2	± 0,05	300	800	1500
MB 4003	5...400	2	± 0,05	300	800	1000
MB 6003	5...600	2	± 0,05	300	800	800

- 1 type
- 2 stroke length mm
- 3 number of positioning points
- 4 repetition accuracy in mm
- 5 speed mm/s
- 6 in the direction of the axis of motion
- 7 perpendicular to the axis of motion
- 8 loadability

Table 2. Technical data of the components (circular motion)

Typ 1	Drehwinkel Grad 2	Anzahl der Positionie- rungspunkte 3	Wiederhol- genauigkeit Grad 4	Geschwin- digkeit Grad/s 5	Dreh- moment N·m 6
MD3001	30...300	2	±0.01	90	32
MD3602	30...330	3	±0.025	90	200

- 1 type
- 2 rotation angle degrees
- 3 number of positioning points
- 4 repetition accuracy, degrees
- 5 speed, degrees/s
- 6 torque N·m

Hungary

CNC Lathe EPA 32Q-01 (Figure 18)

Exporter: Technoimpex, Budapest

Technical data

swing-over diameter over the bed in mm 450
rpm range in rpm 50 to 4000

Yugoslavia

Universal Precision Lathe TG-125 NP

Manufacturer: Prvomajska - TSD - Golubovec

Technical data

peak height in mm 125 (128)
peak width in mm 500
turning diameter over the bed, max, in mm 130
spindle rpms 63 to 4500
longitudinal infeeds, nominal in mm/revolution 0.26 to 0.47
coarse in mm/revolution 0.2 to 3.8
transvers infeeds, nominal in mm/revolution 0.013 to 0.23
coarse in mm/revolution 0.1 to 1.8
threads standard pitch in mm 0.25 to 4.5
steep pitch in mm 2 to 36
power of the drive motor in kW 2.5/3
weight in kg 950

Lathe SP-12-D-500

Manufacturer: Pobeda - Novi Sad

Turning diameter of the bed, max, in mm	280
workpiece diameter for outside processing, max in mm	120
workpiece diameter for inside processing, max, in mm	40 to 150
peak distance, max, in mm	550
turning length, max, in mm	500
dimension of the machine in mm (L x W x H)	3000 x 2300 x 2000
weight in kg	2480

Table 3. Technical data of the evolvant and pitch testing machine

	PFSU 640	PFSU 640 HP	PFSU 640 HPA
1 Werkstückdurchmesser in mm	0 bis 640	20 bis 640	20 bis 500
2 Modulbereich in mm	0,1 bis 20	1 bis 20	
3 Schrägungswinkel in Grad	0 bis 90	0 bis 90	
4 ohne Unterbrechung meßbare Zahnlänge, max. in mm	250	250	
5 Spitzenentfernung, max. in mm	880 (1530)	880 (1530)	
6 Masse in kg			

- 1 workpiece diameter in mm
- 2 module range in mm
- 3 slant angle in degrees
- 4 gear length measurable without interruption, max, in mm
- 5 tip distance, max, in mm
- 6 weight in kg

Table 4. Technical data of the tool sharp-grinding machine

- 1 deep grinding machine
- 2 workpiece outside diameter, max, in mm
- 3 workpiece base diameter, min, in mm
- 4 grinding body diameter, max/min, in mm
- 5 gash grinding depth, max, in mm
- 6 grinding slide path/ grinding path, max, in mm
- 7 grinding slide precision in the working stroke, continuously variable in m/min
- 8 weight, approximate, in kg

	SNC 30	SNC 30 T (Tief-schleifmaschine)
Werkstückaußendurchmesser, max. in mm Z	300	350
Werkstückfußdurchmesser, min. in mm 3	0	0
Schleifkörperdurchmesser max./min. in mm 4	300/150 (160/60)	300/150
Spannutenschleiftiefe, max. in mm 5	50 (50)	90
Schleifschlittenweg/Schleifweg, max. in mm 6	550/500	550/500
Schleifschlittengenauigkeit im Arbeitshub, 7 stufenlos verstellbar in m/min	0,05 bis 16	0,05 bis 8
Masse, rd. in kg 8	4200	4100

Table 5. Technical data of the BOR II robot system

Modul- Nr. 1	Achse 2	Weg S_{max} 3	Geschwin- digkeit V_{max} 4	Achsbewegung 5	
1	X	1000 mm	1000 mm/s	translatorisch, 6 horizontal	verlänger- bar 11
2	Z	2000 mm	800 mm/s	translatorisch, vertikal 7	variabel 12
3	Y	360°	100°/s	rotatorisch um S-Achse 8	
4	R(C)	360°	100°/s	rotatorisch um vertikale Achse 9	
5	S(A)	180°	180°/s	rotatorisch um horizontale X-Achse 10	

- | | |
|-----------------------------|---|
| 1 module number | 8 rotational about the s axis |
| 2 axis | 9 rotational about the vertical axis |
| 3 path | 10 rotational about the horizontal axis |
| 4 speed | 11 extendable |
| 5 axis motion | 12 variable |
| 6 translational, horizontal | |
| 7 translational, vertical | |

Fair Memoranda

The AH Polygraph of the GDR and the Polish foreign trade enterprise VARIMEX sought contracts concerning the redesign of print shops in the Polish Peoples' Republic.

AH Polygraph agreed with the foreign trade enterprise Kovo about exporting roller-rotational offset printing machines into the CSSR.

WMW (Machine Tools and Tools) and the All-Union Association of Stankoimport (USSR) signed export and import contracts concerning mutual deliveries of machine tools and tools, in the amount of 225 million rubles. These include e.g. processing centers, special and standard machines, as well as engineering production complexes. Among other things, it also includes a flexible machine system, delivered by the VEB RAWEMA, for processing transmission housings in the Minsk automobile plant.

WMW agreed with the French conglomerate Renault to deliver machine tools valued at 6 million Valuta mark to France in 1965.* The modern equipment is intended for joint projects in the production of diesel engines.

As a result of a Fair contract, the Polish Peoples' Republic will receive from the GDR lathes with numerical control, grinding machines, as well as car-body presses.

The foreign trade enterprises Robotron and KOVO signed export and import contracts concerning computer technology in the years 1984 and 1985, with a total value of 54.5 million rubles. Thus, the CSSR will procure from the GDR electronic data processing systems, office computers, terminal systems, data acquisition and invoicing technology. The CSSR will export into the GDR electronic data processing systems, minicomputers, photographic readers, keyboards, and printers.

For the first time this year, a central stand appeared in Hall 7, under the motto "Your problem - our solutions." Combines, enterprises, and scientific institutions of the GDR here offered knowledge, technologies, and performances - for the comprehensive and rapid economic utilization of the most recent scientific-technical results.

Six hundred-twenty licenses were sold.

The foreign economic experts paid special attention to the licenses that were offered. For good reason: Just in the last year, according to Dr. Wieck, 620 new licensing contracts were concluded with foreign firms, despite severe competition. "The main share of this belongs to the close collaboration with the USSR and other member countries of the CEMA. But even renowned capitalistic concerns are increasingly putting their trust in GDR performances." The

*Obviously a misprint, should be 1985.

renowned chemical giants TEXACO, British Petrol, Dow Chemical, Hoechst AG, BASF, VEBA, and Ruhrgas belong among these. Indian industries are producing machine tools and polygraphic machines, electrical devices, and diverse chemical products, in accord with GDR licenses. In Algeria, they are producing fittings and pumps. Brazil is using the proven know-how of the Combine Ceramic Works Hermsdorf to produce electroporcelain.

The enterprise TESLA Kolin and ZPA Kosire and their research institutes are strongly specialized in the area of electronic equipment. They are collaborating with the Czechoslovak manufacturers of machine tools and shaping machines. The consequence of this collaboration is that, at the present time, the CSSR has available a copious selection of NC and CNC systems of high technical quality, which are used to control the machine tools fabricated by the Czech machine tool industry. The fact that more than two thirds of the fabricated machines are exported into 70 countries all around the world, among other things, also testifies to the high level of the Czech machine tools. One of this year's exhibits also is the automatic gear wheel production line AUCO 31-2. This is the result of a very successful collaboration between the TST Conglomerate Enterprise TOS Celakovice and the enterprises VEB WMK "7 October" Berlin and the VEB Gear Cutting Machine Factory MODUL Karl Marx Stadt. Other Czechoslovak enterprises which participated in the fabrication of this production line are VIHORLAT Snina and VUKOV Presov.

The metallurgical commerce enterprise, VE Foreign and Domestic Trade Enterprises of the GDR, concluded contracts with the Soviet foreign trade enterprise Promsyrimport concerning the import of more than one million tons rolled steel and steel pipes during the second half of 1984.

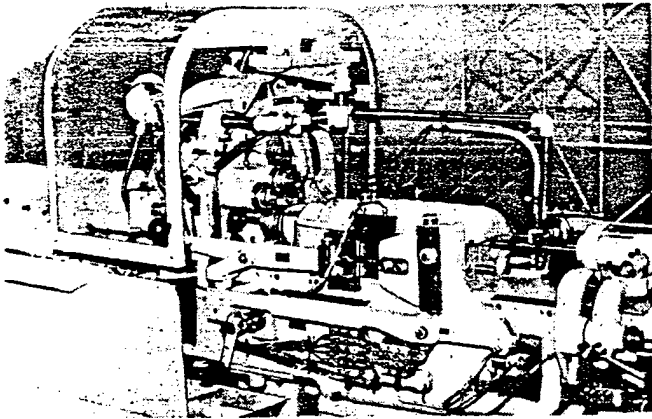

Fig. 4



Fig. 6

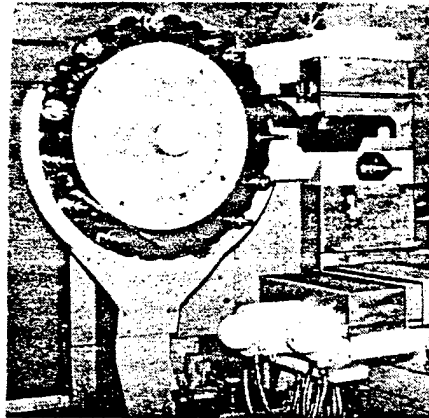

Fig. 5

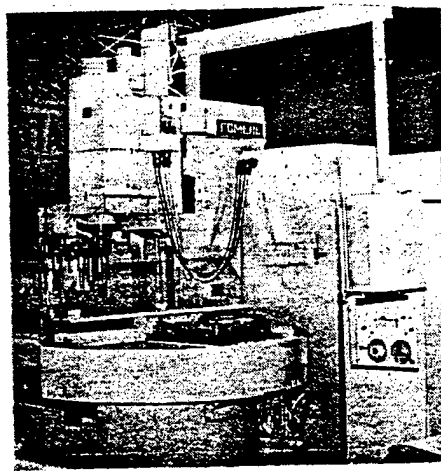

Fig. 7

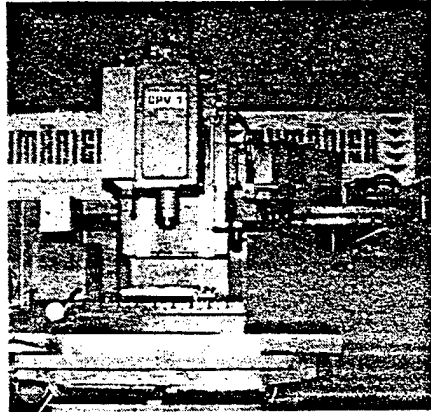

Fig. 8

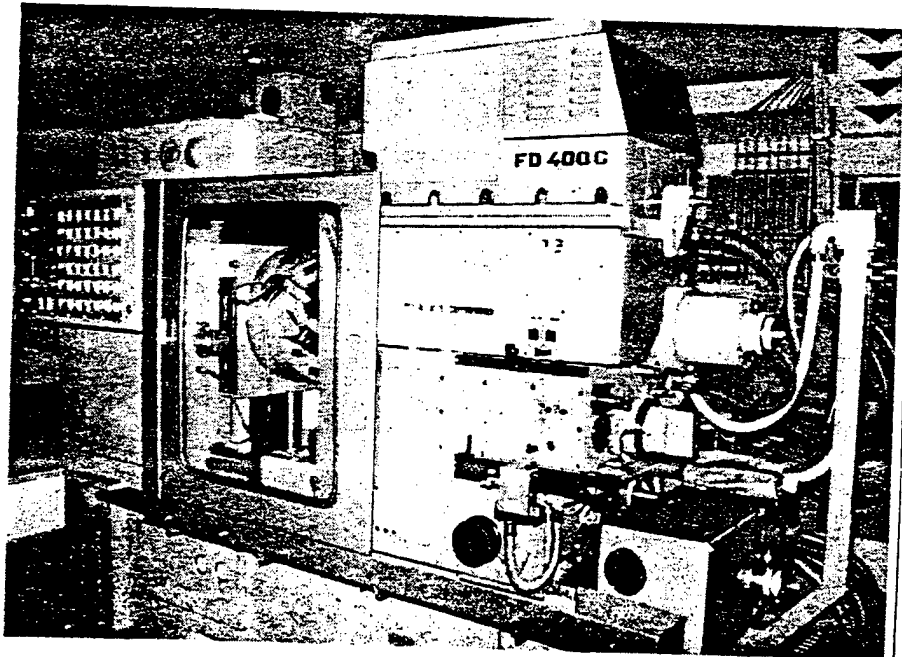

Fig. 9

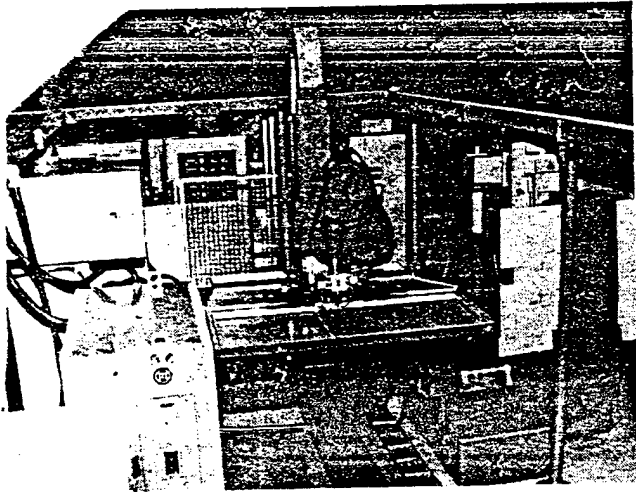

Fig. 10

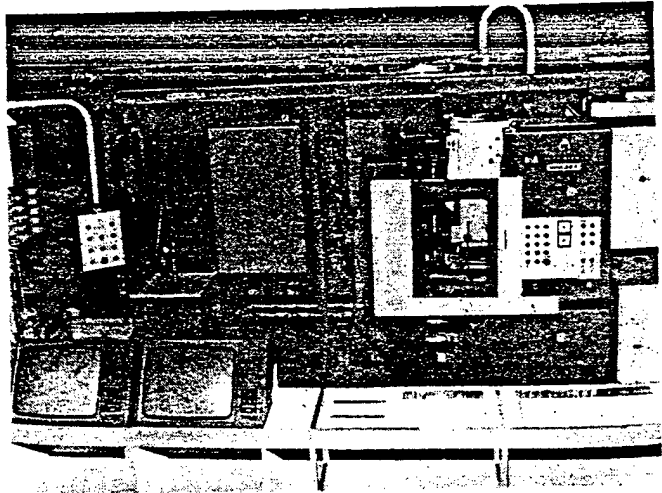

Fig. 11

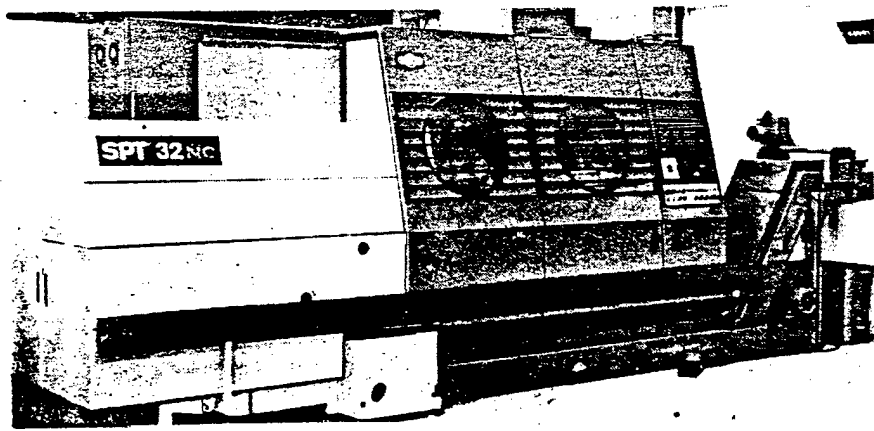

Fig. 12

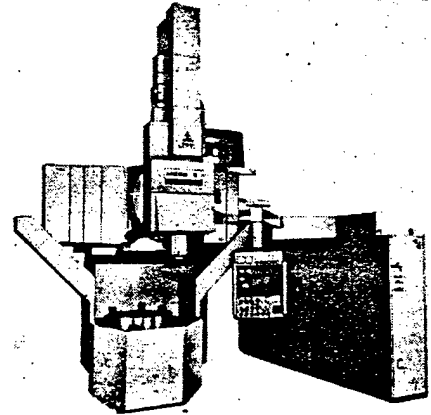

Fig. 13



Fig. 14

Fig. 15

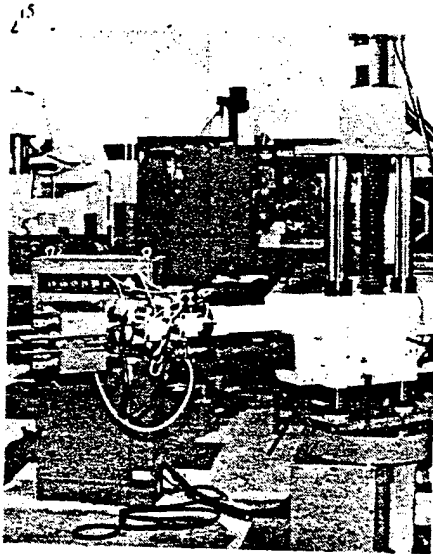

Fig. 16

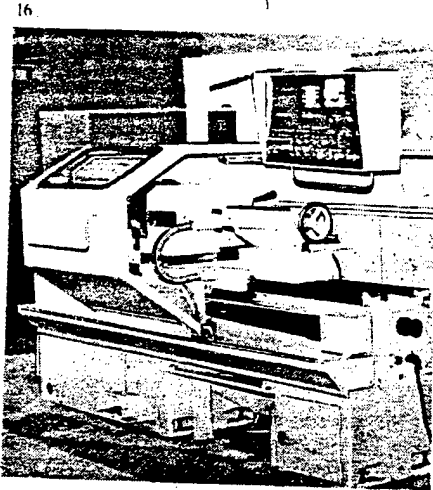
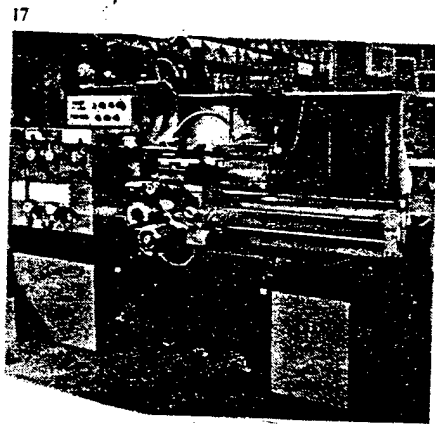

Fig. 17



8348
CSO: 2302/19

GERMAN DEMOCRATIC REPUBLIC

NC PROGRAMMING, MACHINE TOOL INFORMATION

East Berlin FERTIGUNGSTECHNIK UND BETRIEB in German Vol 34 No 7,
1984 pp 440-443

[Text]NC-Programming with AUTOTECH-BOFR 11/DR 11 on office computers

Industrial requirements for simple, rapid, and reliable NC programming depend, among other things, also on the particular device technology. In this connection, the microcomputers that are recently being offered by the VEB Combine Robotron are also becoming more important for the engineering area. They are changing the previous working mode of the engineer towards direct communication with EDP in dialogue form.

The conventional manual forms of engineering (e.g. NC programs or source programs) will decline in the future.

Increased work is being done on the development of user software, among other things for technical production management. One of the first solutions to make the A 5120/30 (BC) office computer more efficient is the program AUTOTECH-BOFR 11/DR 11 for dialogue-oriented NC programming. This program will be presented below.

The program AUTOTECH-BOFR 11/DR 11 is an assembler program in the MABS-1520 programming language. It operates under the SIOS 1526/MINT operating system.

It consists of a basic program with modified modules for individual control variants.

Main components of BOFR 11/DR 11 are the subprograms (UP) and their completion directives according to the UP catalogue (1, 2). A dialogue picture (mask) is stored for each UP and is called onto the screen by its UP number. The programmer is thus offered all obligatory and optional parameters on the screen, so that a search in the UP catalogue is generally obviated. After the

numerical values have been entered, the system performs a syntactic check. If errors are found, the wrong characters are labeled, and the entire control record or the dialogue picture of the UP remains in the entry area for correction. Furthermore, an error comment is outputted.

If a correction is to be made in the last NC record, which is already in the output area, this record can again be transported into the input area by means of another function key.

The most important syntactic tests are:

- allowability of the address words
- allowability of the word format
- allowability of the record length
- completeness of the obligatory parameters for the UP
- allowability of special characters

The program uses paper tape and floppy disks as data media for the finished workpiece programs. When the floppy disk is used, a maximum of 18 (or 36) control programs with 1700 records can currently be stored on each side. The advantages of the floppy disk are its fast and reliable access, rapid output of records on the floppy disk, and less bothersome noise such as occurs around the punch with output on paper tape. Furthermore, the NC programs can be checked and corrected on the screen while they are being set up.

The FZW (Research Center of Machine Tool Construction in Karl Marx Stadt) has developed UP catalogues for drilling, milling, and turning (3, 4), to make NC programming more efficient. These catalogues have already been introduced in industry. In conjunction therewith, the program BOFR 11/DR 11 was developed especially for CNC 600 controls.

But by means of this program one can also develop NC programs for other controls.

The program is not a module of machine programming (AUTOTECH-BOFR 31/DR 41) but is an autonomous program which represents a sensible supplement to manual and machine programming.

Because of its low price, high power, and simple operation, the office computer is especially suited in the engineering department as an NC programming station. It creates the preconditions for fulfilling the initial requirements concerning rapid and reliable generation of NC programs. Through the dialogue and the syntax test, NC programs are generated which reduce testing time on the NC machines and thus increase the productive time of these

expensive systems.

In many cases, the system gives the engineer specific control references already during dialogue-oriented programming (e.g. parameter function, occupation of the UP memory, parameter allocation). These references also contribute to the above result.

Necessary corrections can be made in the NC program quickly and reliably not only by the correction capabilities at the NCM but also by means of BOFR 11/DR 11 in dialogue by way of the screen or through paper tape or floppy disk. Stoppage times of the NC machines are reduced. Furthermore, the correction function (command E/F) can modify and efficiently set up workpiece programs on paper tape or floppy disk according to the principle of type technology.

The mode of operation of the program looks as follows:

After the program (AUTOTECH-BOFR 11/DR 11) has been read in from the floppy disk, the menu appears with all implemented generations and operating modes. By entering appropriate commands (numbers or letters), the engineer selects his desired application. Standard cases are generated and require no entry. Then the entry picture appears, which consists of three regions:

- output region
- input region = active region
- commentary region

The program start symbol (%) appears at the beginning in the input region. The program number is to be entered following this. The entry position on the screen is controlled by the cursor. Each program record is terminated with the ET1 key, which simultaneously and automatically sets the record end character. If the program record is free of error, it is rolled into the output region, and the next record number automatically appears in the input region. The new control information can then be entered record by record.

When entering a subprogram (e.g. "L99"), the dialogue picture (mask) which has been stored for this in the program will appear in the input region. In this case, the engineer enters behind the suggested parameters only the corresponding numerical value from the drawing. The sequence of records to be entered takes place in order of machine processing. After all records associated with the workpiece program have been entered, the program termination character (!) is set automatically through the function key S1. The menu picture again appears to enter further commands, e.g. for paper tape output or for a new workpiece pro-

gram.

Parallel printing or punching while generating the program can be selected by the engineer via the selector keys.

The following equipment is necessary to use the AUTOTECH-BOFR 11/DR 11 program:

The BC A 5120 or BC A 5130 office computer with
-- 64k byte working storage
-- BAB 1 (BAB 2) video screen
-- SD 1152 or SD 1156 printer
-- disk drive for 5.25 inch or 8 inch floppy disk
-- K 6200 paper tape unit or only a paper tape punch

The program is furnished to the user relative to his process (drilling/milling or turning) on the user's own floppy disk in the form of a phase library.

In the future, microelectronics will influence the mode of operation of the engineer by a direct contact to electronic data processing in the form of engineering work stations. The program which has been presented takes a first step in this direction in connection with NC programming. The simple operation of the BC as well as rapid access shortly make it possible to generate NC programs efficiently. The built-in error tests reduce subjective programming errors. The use of floppy disks as NC program memory will further reduce paper tape as a data medium, with all its disadvantages.

References

- (1) UP Catalogue for Turning, FZW Department 422
- (2) UP Catalogue for Drilling, Milling, FZW Department 423
- (3) Gehlsdorf W; Weigel F; Seltner J; Manual Programming of CNC-Controlled Machine Tools with Subprograms. Fertigungstechnik und Betrieb (Production Engineering and Operations) Berlin, Vol 32 No. 8 1982 pp 162-165
- (4) Strass K: Workpiece Programming of Lathes with CNC 665 by Using the Subprogram Technique. Fertigungstechnik und Betrieb (Production Engineering and Operation), Berlin Vol 32 1982 pp 497-499

Friction welding in transmission construction

The high-powered joining method "friction welding" can be used

with great economic success not only in its already familiar application in large scale mass production but also in small scale and medium production involving industrial transmission construction.

In contrast to other well-known manufacturers and operators of friction welding machines, who determine the technical operating data by essentially empirical methods and relative to the particular components, a system was developed in the GDR by means of which technical operating parameters for friction welding can be specified without trial and error involving specific components. Through extensive strength tests and trials of friction-welded components, the suitability of the above system was comprehensively demonstrated.

Possible applications

It is possible to combine economically, by means of friction welding, the unfinished parts for stored transmission components from semifinished goods having various cross sections (up to a diameter of 110mm). In addition to this, further solutions were worked out, to assemble such unfinished parts from elements involving different materials. An example of this are pinion shafts. By using friction welding, it became possible to use lesser quality materials for the shaft elements of pinion shafts, and thus to accomplish a saving in price. These materials could be welded with typical gear wheel materials. Well-aimed studies here found material combinations which did full justice to a subsequent tempering treatment. This design of pinion shafts, which was effected on the basis of a material substitution, has been practiced for some time and is yielding good economic results, with high use values of the components.

Another application of friction welding was made possible by the development of appropriate special equipment and supplementary modules for friction welding machines, by means of which short, flange-like unfinished parts for mechanically switchable multiple-disk clutches could be welded economically.

This technology also has already proven itself successful for a long time.

Advantages

The advantages of friction welding unfinished parts for pinion shafts and mechanically switchable multiple-disk clutches consist in the welding together of various semifinished goods which make it possible for the shape of the unfinished part to approach closely to that of the finished part, resulting in a minimal

machining effort. Friction-welded unfinished parts are much more economical than drop-forged or fine-forged components, since no cost-intensive dies are needed and the required unit times for friction welding are very low.

Horizontal surface grinding machine BRH 40 B
Exporter: Strojimport, Prague

This machine is intended to grind flat surfaces and workpieces made of steel, cast iron, or other metals where high working precision and surface quality are required. Depending on their shape and dimension, the workpieces are clamped either on a magnetic clamping plate or, by using suitable clamping devices, directly on the table clamping surface.

The horizontal surface grinding machine BRH 40 B is produced in the following three designs, depending on the level of automation of the working cycle:

-- BRH 40 B -- I: this design has available only the basic automatic equipment, i.e. the automatic longitudinal advance with continuously adjustable speed and the automatic transverse advance of the grinding spindle head, either with continuously variable speed or with an interruption at the reversal points. The machine is equipped with a manually operated vertical advance and a machine-controlled vertical rapid motion.

-- BRH 40 B -- II: compared to design I, the vertical feed of the grinding spindle head is here accomplished automatically. The machine can grind in a non-closed automatic working cycle, which is composed of roughing, trimming, and spark-out. The operator manually switches off the machine and resets the grinding spindle head into its starting position.

-- BRH 40 B -- III: this machine differs from design II by the possibility of working in a closed automatic cycle, consisting of roughing, trimming, spark-out, resetting the grinding spindle head into its starting position, and stopping the table advance. This automatic working cycle can be controlled by using a measuring control unit.

The BRH 40 B machine is produced in two length versions with a working table length of 1000mm and 1500mm. The table width is 400mm.

Plano-milling machine FSS 80 NC
Exporter: Strojimport, Prague

This newly developed milling machine is characterized by its de-

sign comprising a fixed bed, a spindle head that can be adjusted vertically and transversely, and a numerical track control. The working table moves longitudinally on the fixed bed. The machine stand is rigidly connected with the bed. The spindle head console housing is moved at the vertical guide of the machine stand, and the actual spindle head is moved in its transverse guide. The position of the working table therefore remains unchanged in the vertical and in the crosswise direction.

The tappet spindle head has a revolver head in front, with two spindles -- a horizontal one and a vertical one, which automatically move into the working position during the working cycle. Both spindles are equipped with hydraulic-mechanical tool clamping.

All guide rails are lubricated automatically. A separate oil pump is provided for lubricating the spindle transmission box.

Technical data

Area of the working table	800 mm x 2000 mm
Longitudinal motion of the table	2000 mm
Transverse motion of the spindle head	800 mm
Vertical motion of the console	1000 mm
Power of the spindle drive motor	15 kW
Range of spindle RPMs	9...2000 RPM

Contributions towards shaping the working environment

The Office for Industrial Formshaping initiated a new non-periodic publication series in April 1984, namely "Contributions Toward Shaping the Working Environment." Among other things there appeared a 120 page brochure, "The Video-Screen Workstations -- Directives Towards Their Design." This gives an outline of ergonomic problem areas arising in connection with the setup of video-screen workstations. Besides recommendations for the ergonomic design of the technical components of the workstation, it contains dimensional designs for workstations, and specific requirements for these workstations as regards hygienic factors. Furthermore, directives are given concerning the aesthetic aspects of designing video-screen workstations, concerning the essential techniques of carrying out dialogue, and concerning the optimal way of presenting information on the screen. The directives are tailored to the needs of the user of the new technology and address themselves to users of computer technology, especially ergonomic engineers, engineering psychologists, doctors of occupational medicine, engineers, constructors, and programmers.

The brochure can be obtained for 20.00M from the Ministerial Council of the GDR, Office for Industrial Design, Department of the Working Environment, 8020 Dresden, Semperstr. 15, PSF 43. (Collective orders will receive preference).

8348

CSO: 2302/18

LASER-GUIDED MEASURING SYSTEM FOR PRECISIONING DEVICE

East Berlin FEINGERAETETECHNIK in German Vol 33 No 9, 1984 pp 410-412

/Article by Dr R. Schroeter, Engineer, Dresden Technical University,
Department of Industrial Metrology, Production Engineering and Machine
Tool Division/

/Text/ Laser position sensors (LWMS) have established themselves for years as precision length comparison standards to measure geometric and kinematic parameters during the acceptance and routine checking of measuring equipment and machine tools, and for the performance of special position-measuring tasks. Compared to conventional means of measurement (measuring rods, gauge blocks, and auxiliary gauges, etc.), LWMS offer a series of special advantages:

- Rapid and problem-free adjustment of the laser beam, which is radiated in the visible wavelength range, at the appropriate measurement level, and easy handling of the total measuring equipment, since 80 percent and more of the radiated light can be stopped down.
- Rapid performance of the measurement, i.e. as soon as the measurement position has been reached, the measured value is also ready. Thus the machine stoppage times are short.
- A large measurement distance extending over several meters, because of the large coherence length and the high spectral intensity of the radiation. The measurement length is finally limited here by air turbulences and intensity losses.
- A high degree of automation by using peripheral units to process and display the measured data.
- By using special optical components, the measurement of other geometrical variables (angles, linearity, alignment) or also a multi-axis path measurement in the x, y, and z direction become possible.
- High resolution of measured data up to 0,01 μm .
- Interference measurement of lengths, angles, and velocities.

- The costs for an LWMS do not depend on the measuring length.
- Application without hazard, as a consequence of the low laser power, which is less than 1 mW.

The laser position sensors that are used in the GDR are generally He-Ne single-frequency lasers with frequency stabilization. Here the laser tube emits coherent light in the red, visible spectrum (1) (2) (wavelength in vacuum $\lambda_{vac} = 632.99141 \text{ nm}$).

Compared to older variants, the new systems (3) (4) (5) offer significant advantages such as

- separate interferometer, and thus temperature and vibration insulation with respect to the laser head,
- connection to or integrated component of an automatic device for correcting for ambient conditions, with extended compensation range,
- increased beam power, and thus a larger measurement range and higher loss compensation with beam stop-down,
- higher maximum processing rate up to 300 nm/s,
- simple beam deflection as a consequence of variable polarization properties for multi-axis position measurements,
- minimized construction units of laser beam source, power supply, and display unit, interferometer and reflector,
- utilization of microcomputers to calculate the measured variables and to take into account the ambient corrections,
- averaging several measured values in the case of strongly fluctuating indicators,
- increased resolution by supplementary units in connection with length measurements,
- standard interfaces to couple external evaluation units.

Since the measurement uncertainty of the LWMS is influenced by the state variables of air temperature T_A , air pressure P_A , and humidity ϕ_A of the medium through which the beam passes, compensation of these interfering variables is absolutely necessary, either manually or automatically. The sensors to detect these influences therefore must be affixed in the immediate vicinity of the measurement path through which the beam passes, especially the temperature sensor (thermometer with divisions to a tenth of a degree). Regular and careful calibration of all sensors should be noted here. Another source of error for these measurements is the generally unknown linear

expansion coefficient α of the object being tested. The value $\alpha_{\text{steel}} = 11.5 \cdot 10^{-6} \text{K}^{-1}$ can here fluctuate by $\pm(2 \dots 3) \cdot 10^{-6} \text{K}^{-1}$ depending on the composition of the material!

Presupposing careful measurement setups and correction of ambient influences, the measurement uncertainty is about $\pm(1 \dots 2) \mu\text{m/m}$. Disregarding the error sources listed above, the measurement uncertainty can rise considerably, however.

1. Coupling of the LWMS With Peripheral Devices

The development and application of laser interferometers for path measurements and for positioning of measurement equipment and machine tools has recently reached a status which offers no difficulties in laboratory and industrial use. Consequently, especially the expansion of applications to solve the most various measurement tasks and the use of computers for computer-supported evaluation have recently been emphasized.

The use of computer technology with its manifold possibilities of storing, processing, and outputting the measured data while using manifold programs brings with it a modification of the measuring methods and an objectification of the measured results. This likewise enhances the advantages of laser interferometers, advantages which were mentioned in the introduction.

Besides making the measurements and their evaluation more efficient (reduction of measurement time, reduction of interfering influences), while simultaneously increasing their accuracy (taking into account and correcting certain error effects, calculating "derived" statistical quantities), it is in particular possible to integrate the measured results into the data flow for the overall production control.

Figure 1 shows the basic coupling possibilities between the LWMS and the peripheral units.

1.1 Off-line Variant

Generally speaking, large amounts of data are generated. Consequently, simple noting down or recording with a printer, and subsequent manual processing of the results with calculators or desk-type computers must be reserved to experimental individual cases and otherwise makes little sense.

For numerous measurement tasks it is suitable and thoroughly acceptable to record the digital measurements by means of a serializing system and a printer or to store them by means of a rapid punch. The resultant paper tape can then be fed into a computer.

1.2 On-line Variant

Direct coupling between the LWMS and a computer offers the advantage of real-time processing for sometimes considerable quantities of measured data. Here

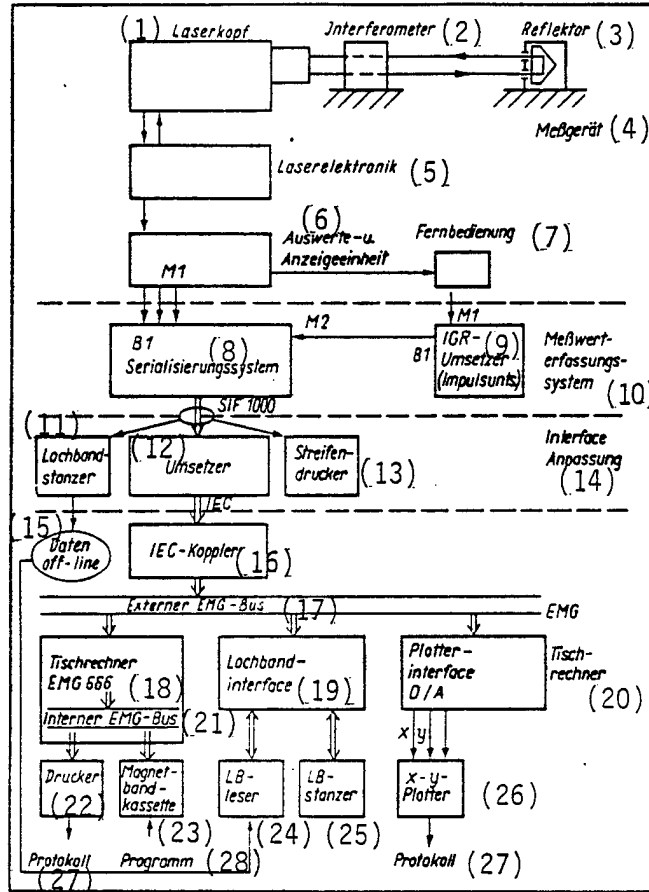

Figure 1: Coupling of Laser Positioning Systems With Peripheral Units

- Key:
- | | |
|---|-------------------------------|
| 1. Laser head | 16. IEC coupler |
| 2. Interferometer | 17. External EMG bus |
| 3. Reflector | 18. Desk-top computer EMG 666 |
| 4. Measuring unit | 19. Paper tape interface |
| 5. Laser electronics | 20. Desk-top computer |
| 6. Evaluation and display unit | 21. Internal EMG bus |
| 7. Remote operation | 22. Printer |
| 8. Serialization system | 23. Magnetic tape cassette |
| 9. IGR converter (pulse step-down unit) | 24. Paper tape reader |
| 10. Measurement-data acquisition system | 25. Paper tape punch |
| 11. Paper tape punch | 26. x-y plotter |
| 12. Converter | 27. Record |
| 13. Strip chart printer | 28. Program |
| 14. Interface matching | |
| 15. Data off-line | |

the choice of computer depends on the task, the peripherals, and the software. In the area of industrial metrology of Dresden Technical University, the use of the KRS4200 minicomputer and especially of the Hungarian EMG 666 desk-top computer were investigated.

Here it must not be forgotten that the use of measuring systems controlled by minicomputers requires so much expenditure in terms of equipment (measuring devices, electronic matching units, data couplers, storage units, and other supplementary subassemblies), that their use makes economic sense only under special conditions.

1.3 Microcomputer Variant

With the development of programmable computer modules (microprocessors), the path was opened up towards a new, functionally expanded generation of measuring devices, and the turn towards automation was taken into account more strongly.

Measurement systems controlled by microcomputers are to be encountered in the most recent equipment designs of the laser measuring system LMS 100 of the VEB Fine Measurement Dresden in the Carl Zeiss JENA Combine, and in the laser interference measuring system LIMS of the VEG Metra Blansko, CSSR.

2. Experience in the Application of LMWS in Connection With the Acceptance of Coordinate Measurement Machines and Machine Tools

2.1 Determination of Positional Deviation and Uncertainty

For efficient quality control, the evaluation of the working precision of a completely assembled measuring system or machine tool from the deviations is an important criterion in positioning a subassembly. Here, the unloaded machine must be tested without workpiece and tool. Statistical evaluation procedures permit reliable evaluation of the working accuracy.

The measurement process to determine the deviations in the positioning of a subassembly, according to standards, is as follows (6) (7):

Specify a certain number of theoretical positions along the axis being tested.

Manual or automatic approach to the prescribed theoretical positions.

Sensing the actual paths by means of LMWS after every positioning process while stationary.

Determining the parameters on the basis of differences between the actual and theoretical values according to standard;

- positional deviation (error)

$$\Delta x = x_i - x_i \text{ theoretical}$$

- Positional uncertainty
- Positional fluctuation as six times the average standard deviation of the measured data for both directions of approach
- The reversal range as the difference of the average deviations of both directions of approach.
- The mean deviation $\Delta\bar{x} = \bar{x}_{i+} - x_{i-}$ theoretical for positive and negative directions of approach ($\bar{x}_{i+}; \bar{x}_{i-}$).

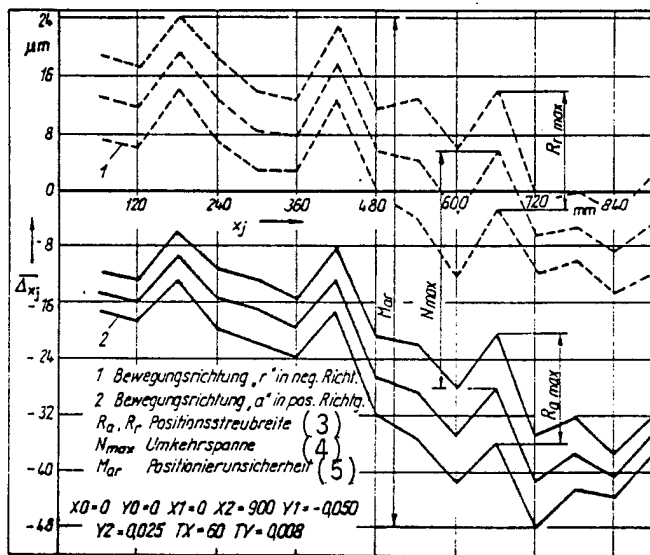

Figure 2: Testing a Slide With Linear Motion, in Both Directions of Motion
Key:

1. Direction of motion "r" in the negative direction
2. Direction of motion "a" in the positive direction
3. Ra, Rr positional scattering width
4. N_{max} reversal span
5. Mar positioning uncertainty

Figure 2 shows the statistical parameters for a machine axis for both directions of motion.

With the investigated measurement systems and machine tools, the objective boundary conditions (availability of the machines, peripheral units, etc.) made it necessary to determine and evaluate only the positional deviations:

- Three-coordinate measuring machine DELTA BL with measurement ranges x/y/z 500/2400/2050 mm (Figure 3)
- Three coordinate measuring unit DKM 1-300 D: x/y/z 320/220/160 mm
- Automatic circular cold saw: x = 15,000 mm
- Measurement and adjustment line for tape measures: x = 20,000 mm
- NC longitudinal milling machine with portal construction: x/y/z/w 12,500/7,430/1,000/3,200 mm
- Single-stand coordinate drilling machine BKOE (expansion unknown) 630 x 1,000: x/y 710/400 mm, etc.

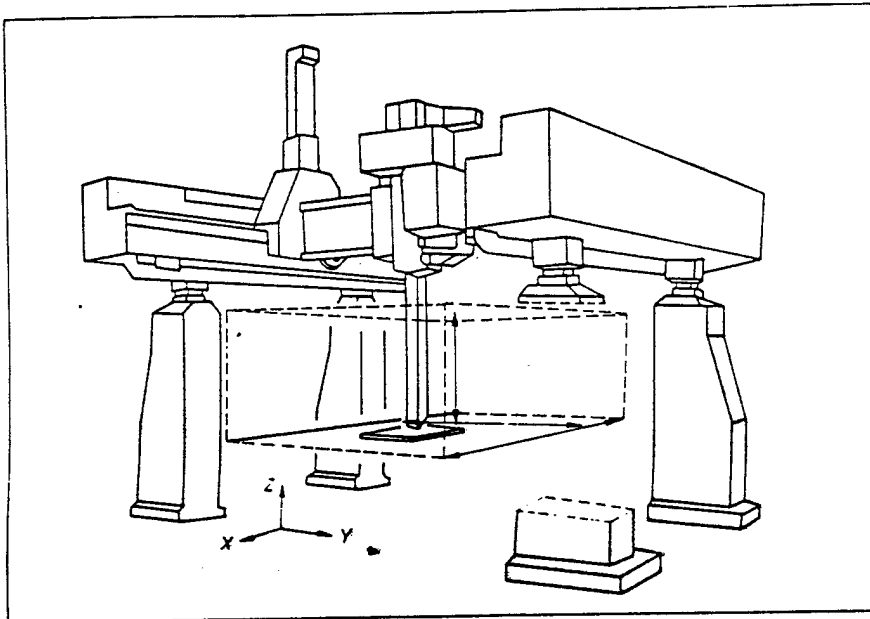

Figure 3: Testing the Positioning Accuracy of a Three-Coordinate Measuring Machine

For example, it was easy to recognize the relatively large changes of systematic deviations in the area of scale impact points as a consequence of deadadjustment of the scale elements.

Another application of LWMS concerns the evaluation of the working precision of the positioning table of a photolithographic device for the production of microelectronic circuits. The smallest paths with step widths of 1,000 mm, 0,480 mm, 0,010 mm and some special steps are programmed by the NC control of

the device along the particular path being tested. The advantage of the measurement primarily consists in the fact that the measurement time is significantly reduced and thus the influence of temperature on the test object is essentially excluded.

By means of supplementary equipment, it is possible to measure deviations from linearity and from this it is possible to determine planarity or the accuracy of right angles (8).

2.2 Use of LWMS in the Kinematical Investigation of Measurement Machines and Machine Tools

Besides geometrical testing under static conditions, LWMSs are also suitable for the kinematic investigation of the transmission behavior of measurement machines and machine tools. The kinematic behavior between rotational and translational motions is here generally investigated.

The Department of Industrial Metrology of Dresden Technical University in this connection performed extensive laboratory and industrial investigations concerning pitched measurements on long threaded spindles and concerning the testing of whirl thread machines.

Building on the studies of trapezoidal threaded spindles, the computer program "LEITSPINDEL" was developed for the complete evaluation of pitch measurements on threaded spindles. This program is designed for the programmable Hungarian desk-top computer EMG 666 with extensive plotter software.

In combination with the universal length measuring machine ULMM 3 m, the LWMS, and a special, cardanically suspended drive unit, 1, 10, 100, or 1,000 measurement points can be interrogated per revolution. The measurement sequence is fully automatic and the appropriate number of measurement points per revolution is scanned through a coupled incremental rotational angle stepper. After the preselected number of angle stepping pulses has been reached, the instantaneous counter status of the LWMS is transferred via an intermediate memory to the printing/punching system or on-line directly to the computer.

The program "LEITSPINDEL" makes possible the following evaluation:

- Data transfer from punched paper tape or on-line as measured values x_i , and calculation as well as storage of the deviations (errors) f_i

$$f_i = x_i - P \frac{i}{MP} - x_0$$

P = pitch of the threaded spindle

i = number of measurement points beginning at 0, which are used for processing the measured data

MP = measurement points per revolution

- Graphical representation of the behavior of the pitch deviation $f_i(x_i)$ on a plotter (Figure 4)

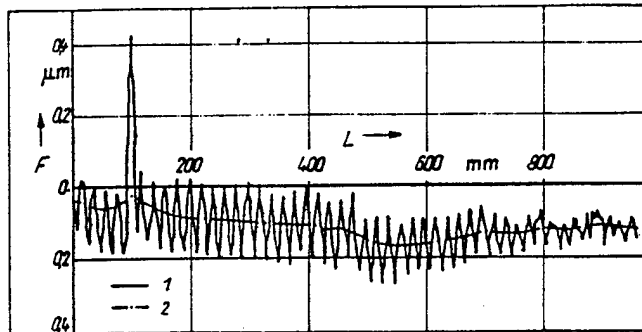

Figure 4: Measurement Record (Plotter Chart) of a Spindle Measurement (Trapezoidal Thread Tr 40 x 20; 1. Pitch Deviation; 2. Mean Pitch Deviation)

- Digital filtering of the pitch deviations with selectable wave separation lengths. In this way, periodic pitch deviations of different wavelength as well as progressive deviations can be isolated and suppressed.
- Frequency analysis to decompose the pattern of pitch deviations into the amplitude spectrum of periodic components, with graphic representation of the amplitude spectrum.

The use of computer technology makes possible a rapid and efficient processing of measured data connected with pitch measurements of threaded spindles. In combination with a plotted program, it is also possible to give a universal representation.

3. Summary

The use of LMWS in industrial metrology permits extensive tests on measurement machines and machine tools with great precision. A high degree of automation with short measuring times and rapid availability, as well as objectivity of measured results, are an ideal presupposition for the continuous or periodic monitoring of machine tools, machine systems, coordinate measuring devices, and fine mechanical devices for microelectronics. Some measurement tasks are possible and sensible only by means of computers. Because of the presently still high equipment expenditure, the more rapid on-line variant certainly can be replaced by off-line operation. Altogether, LMWS and the use of computer technology afford excellent opportunities for automatic quality control.

Table: Measurement Record of Positioning Uncertainty During a Slide Run

Date: 10 November 1982
Specimen: Leading Spindle
Measurement Points: 15
Number of Cycles: 5
Range of Motion: 900
Fluctuation Width max.: RA/RR 0.0153/0.0187
Reversal Spin max.: 0.0349
Uncertainty: 0.0724
Max/min: 0.0243/-0.0481
Plot: X0/Y0/TX/TY
0.0000/0.0000/60.0000/0.000

BIBLIOGRAPHY

- (1) Bechstein, K.; Sumi, K.: The Use of Laser Interferometers in Scientific Device Construction. FEINGERÄTETECHNIK (Fine Device Engineering), Berlin 29 (1980) 2, pp 81-84.
- (2) Petru, F.: Properties of Single-Frequency Lasers and Laser Interferometers, Fabricated in the CSSR. FEINGERÄTETECHNIK (Fine Device Engineering), Berlin 25 (1976) 6, pp 252-256.
- (3) The LMS 100 Laser Measuring System. Company document of the VEG Fine Measurements Dresden in the Combine VEB Carl Zeiss JENA, No. 261083.
- (4) The LIMS Laser Interference Measuring System. Company document of the n.p. Metra Blansko, CSSR, 1983.
- (5) Petru, F.; Krsek, J.; Popela, B.; Stejska, A.: Laser Interference Measuring System and its Application. FEINGERÄTETECHNIK (Fine Device Engineering) 29 (1980) 11, pp 487-489.
- (6) TGL 33734 (11/79): Deviations and the Positioning of a Subassembly; Test Methods.
- (7) VDI/DGQ 3441: Statistical Testing of Working and Positioning Precision of Machine Tools (1977).
- (8) Popela, B.: Linearity Measurements With a Difference Laser Interferometer. FEINGERÄTETECHNIK (Fine Device Engineering) 30 (1981) 2, pp 63-64.

8348
CS0:2302/16

INSTITUTE DIRECTOR ON SEMICONDUCTOR DEVELOPMENT

East Berlin SPECTRUM in German Vol 15 No 9, 1984 pp 19-22

[Interview with Prof Dr Werner Bertoldi, Director, Institute for Semiconductor Physics, Frankfurt-Oder, by Elisabeth Manke: "Greatest Expense for the Smallest Components"; date and place not specified.]

[Text] Components measuring only a thousandth of a millimeter optimum qualities. At this time they are still the product of laboratories engaged in semiconductor research. However, their entry into the microelectronic industry is imminent. Our guest, director of a research facility designed for this field, reports what, besides this fascinating result, may be expected of microelectronics.

Prof Dr Werner Bertoldi, born 1934, chose the field of semiconductors very soon after taking his physics degree in Leipzig. His diploma dissertation was devoted to semiconductor field emission. A subsequent internship with Academy member Gustav Hertz was followed in 1963 by work at our Academy, initially on underwater shock waves by wire explosions, later on the material features of silicon monocrystals. Since 1971 he has been director of the Institute for Materials Processing. In 1983 he was appointed a full professor and director of the Institute for Semiconductor Physics at the Academy of Sciences in Frankfurt (Oder).

In recent years, microelectronics and semiconductor physics experienced a sweeping development. For the future also it offers tremendous though not yet sharply defined possibilities. At some time or other, someone will succeed in storing about 1,000 typewritten pages on a chip no more than 7 mm long. At some time or other, molecules--so-called organic semiconductors--may win the race against silicon, the present favorite. Still, a lot remains to be done before then.

SPECTRUM: The Institute for Semiconductor Physics at Frankfurt (Oder) has concentrated on microelectronics only in the past few years. How did this development proceed?

Bertoldi: Initially the (then) Third Institute for Physics and Technology specialized in plasma physics. When it was reorganized as the Institute

for Materials Processing, assignments from the sphere of the shaping of materials were added. In the early 1970's we dealt with the physical bases of the precision treatment of engineering and semiconductor materials. Though we are now able to draw on our experiences with silicon as a material, the frequent changes in research emphasis left some traces. After all, however capable a research assistant, his efforts are vitiated when he is compelled to go back to square one every 3 or 5 years. At the present time our assignments are of longer range, in general terms they refer to research relating to microelectronics, both in terms of physics and technology. Since the Institute for Semiconductor Physics in Frankfurt (Oder) was established in December last, our working conditions have improved in many respects. The technical equipment of our laboratory buildings provides satisfactory conditions for experimental research. With the exception of the Falkenhagen branch, the fact that the work, hitherto carried on in three locations, now proceeds virtually under one roof, is a contributory factor.

SPECTRUM: Microelectronics offers itself to us--and most likely to you also--in a flood of scientific information, from newspapers, periodicals, at conferences and congresses--all of them constantly proclaiming new discoveries that are all too often given a spectacular presentation. Does that disturb you?

Bertoldi: To be sure, it needs the hide of an elephant not to be disconcerted and, amidst all this variety, to remain able to separate the wheat from the chaff. Some trial balloons are launched, and we must learn to recognize them. That alone explains why our own basic research is indispensable. It is my maxim that we need first of all to have a very clear idea of where we wish to go. We know quite definitely what we have to accomplish by the end of 1985, and we are also well aware what awaits us through 1995. I believe that good judgement is imperative, and it is equally important not to lose from sight the objective to be achieved. At the same time, our approach must remain flexible. We should not close our eyes to certain trends distinguishable internationally or to partial solutions that might well be useful. If, for example, a new plasma etching process is publicized that offers a much more suitable method for the etching of structures, we would be quite unrealistic not to adapt it for our purposes.

SPECTRUM: You are among those able to best classify the developments of microelectronics from the standpoint of your own research. Is the theoretic preparation of our semiconductor physics advanced enough to offer our industry steadily new technological solutions relating to microelectronics?

Bertoldi: Provided you assume that microelectronics is not an end in itself, you have in part gotten your answer. Its objectives follow social needs, to some extent speed ahead of them. A modern national economy without electronics is unthinkable; to function, microelectronics is stimulated by virtually all sectors and, in turn, influences them. Just remember automation in the construction of machine tools, in the chemical and printing industries, power plants and consumer goods production. The integrated circuit is the core of microelectronics, and in the past 5 years we have

pushed ahead with its development at an extremely fast rate. In 1983 the GDR produced 400 types of active components; each year another 60-100 new printed circuits are added. By now we are producing a major portion of the components needed in the GDR economy. Of course, 400 active types of components are by no means enough to satisfy the requirements of a highly developed national economy. On the other hand, we do not need all the 10,000 different types available internationally.

SPECTRUM: Would it not be reasonable by the standardization of components to increase their range of use and, at the same time, limit the total volume of components needed?

Bertoldi: This idea indeed suggests itself. However, before replying to your question in detail, let me draw your attention to some problems. Component development is very costly. Depending on the extent of complexity of the printed circuit, its development in the laboratory may amount to anything between M1 million and M50 million. Production is economic only if large series of the same type are manufactured. Your question about standards is therefore quite justified from the aspect of the improvement of efficiency, because our national economy needs a wide range of components but not all of them in large quantities.

Our republic is not the only one to encounter problems with regard to cost/profit ratios. In other countries, therefore, a relatively large volume of components of a particular type tends no longer to be completely finished, so that these components may be subsequently more easily adapted to their eventual use. We have begun to do that, too. This so-called gate array technique allows us to satisfy a variety of requirements from all national sectors by a basic range of components. Such standardized components have been aptly named semicustomer-desired circuits.

SPECTRUM: Is the process of miniaturization likely to continue much longer? Will we not soon reach the limits of the feasible in terms of physics?

Bertoldi: I am quite sure that miniaturization will continue well beyond the year 2000. For one, physics teach us that components with structural measurements of a few tenth millimeters are in principle able to function (see SPECTRUM No 1/1984), for the other, we see steady improvements in the technical-economic parameters of components, such as speed of operation, input and costs per function. More and more complex components can be produced. For the past 15 years (about), the numbers of integrated components per circuit has doubled each year (!). In our republic it is now around 50,000. The fact that the extent of integration is rising steadily, means that the structural dimensions of components need to be smaller. However, not all functional components are equally suitable for miniaturization. Malfunctions occur and adversely affect their performance. We do indeed come up against limits in the case of some components. We must therefore conceive new ideas, find new approaches. In our institute we are currently studying a principle that may at some time in the future permit us to produce components with storage functions in the submicrometer sphere. We already have such components in our laboratories, admittedly in dimensions comparable to conventional ones. By mid-1985 we intend to produce such components

on the basis of very tiny structures and thereby create the prerequisites for the production of the 1990's. Storage components with such operational components are not yet available at international level. We are working on this in cooperation with other scientific facilities of our republic, in particular the Ilmenau Technical College and the Karl-Marx-Stadt Technical College as well as with other institutes of our Academy.

SPECTRUM: Are you also dealing with problems ranging to the distant future, and which might seem to us now like pure fantasy?

Bertoldi: Your question touches a sore spot. Our subject matter is per se oriented to the long term. On the other hand, the GDR microelectronics industry impatiently awaits our results, so that we are necessarily employing almost all our capacities in assignments designed to provide the preparations for the technologies and components needed in the next 5-10 years. That is a natural imperative but leaves us short-handed for tackling the issues you have addressed. Still, some smaller groups do direct their attention to unconventional but interesting problems. To cite an example: If we were to master the production of semiconducting layers on insulating substrata, it would be possible to advance to the third dimension and create integrated circuits with spatially arranged function components. This is immensely interesting and involves possible surprises in the meaning of your question.

SPECTRUM: Are you still following the old established method of the director regularly passing through the institute and, at their places of work, asking the members of the staff directly: Did you discover anything new?

Bertoldi: That is the ideal, but I do not manage to do that. In our old building I still knew all the personnel. Here it will take a while to reorientate myself among 300 staff. I do try, though, to keep an eye on our young scholars. We are fortunate in being unable to fob them off with routine assignments, simply because we have such a load of work. And here I am of course very interested in finding out who does what, how the young man or woman handles things. After all, it is imperative for us to be able in the future also to keep up with international standards in microelectronics.

SPECTRUM: Does that mean we have already caught up with the pacemakers, Japan for example? Or is it possible to go our own way without duplicating their solutions?

Bertoldi: I am sure that I am not telling you anything you did not know before by noting that we help determine international standards in some fields of microelectronics. We may also claim that components from our republic enjoy a good reputation at international level. To return to our institute, we may boast of some achievements definitely up to international standards. One of them is the use of intrinsic gettering. This involves the following: Some 80 percent of all crystals used are currently bred by the Czochralski process. They include 100 times more oxygen than crystals produced by the zone floating process. At high-temperature treatment of silicon, Czochralski crystals suffer crystal damage. The originally quite perfect crystal has its structure upset, and oxygen clusters emerge, causing defects in the form of stacking faults and loop dislocations in the material.

This has the inevitable result of a particularly high failure rate of components at this point. It is therefore imperative to work with material that is free of defects and remains so in the course of the technological process.

SPECTRUM: Two responses appear conceivable: either abandoning silicon or utilizing these defects?

Bertoldi: These are the obvious ideas. The first must be discarded, because silicon has basically the same significance for electronics as iron has had for metallurgy for the past 3,000 years. The real solution is the control of oxygen in silicon. We are deliberately using the oxygen present in Czochralski silicon to keep the material free of defects precisely where it matters--precisely by intrinsic gettering (illustrations 3 and 4). The technological objective of such gettering is, on the one hand, that of a defect-free zone on the surface and to a certain depth, and on the other hand the formation of sufficient oxygen precipitate dislocation complexes in the crystal volume as to getter away the heavy metals diffused in them at the technologically needed high-temperature steps. In other words, we purposely allow crystal defects to arise and draw other surface impurities into the volume. The surface layer--and only the surface layer--is technologically relevant for the production of components--thus remains free of defects and free of impurities.

We have transmitted this ancillary technology to the Erfurt Microelectronic Combine VEB. Last year a collective obtained the National Prize for this achievement. The process demonstrates the possibility of adapting the basic substance to technology. There is thus no need to fall back on other materials.

SPECTRUM: You mentioned the word "transmission." What in fact does that imply?

Bertoldi: We have been able to establish a well functioning cooperative division of labor with many facilities and enterprises in the GDR. Still, the transmission of scientific perceptions is not an easy matter; innovations have a hard time in microelectronics, too. Whatever has been tried and tested tends to suffer from an inertia factor. A works director cannot be quickly persuaded to convert his production unless the results definitely promise a greater profit.

This is not to say that we should complain about our partners. Cooperation with the Frankfurt (Oder) Semiconductor Plant has a good tradition in the institute and enjoys improved conditions since the establishment of the Academyindustry microelectronics group in March 1983. Without diminishing the legal independence and responsibilities of the partners, work is being coordinated in all crucial fields of interest to both parties. That applies, for example, to the joint coordination of the long-range research strategy and performances, the joint utilization of high-quality equipment and of the libraries. The Frankfurt (Oder) Semiconductor Plant VEB has furnished effective assistance in the conversion and operation of research equipment. This afforded considerable opportunities for regional rationalization.

We recorded some successes in the field of crystal processing, especially with regard to the production of lithium-niobate disks. Last year this result was taken over and applied on the basis of semifinished production by the Teltow Carl von Ossietzky Electronic Component VEB. We also carried out mathematical model studies of semiconductor technology equipment. We calculated how such diffusion equipment may be run more economically. The throughput of this equipment would thereby more than double.

Our earlier successes have shown that it is imperative for the research collectives to set themselves very precise objectives, realization of which depends on a properly conceived division of labor. That is the only way nowadays to carry on goal-directed forward research.

Established on 22 December 1983, the Institute for Semiconductor Physics is the latest institute of the GDR Academy of Sciences. Issued from the Berlin-Rahnsdorf Institute for the Physics of Materials Processing, which began in 1972 to carry on scientific investigations on the processing capability, behavior and qualities of the semiconductor material silicon. In the mid-1970's, beginning of the research on the physics and technology of microelectronic components based on silicon.

Including the Falkenhagen branch, some 320 staff, more than 100 of them university graduates. Current key issues: Bases for the manufacturing technology of components with the further diminution of their lateral and vertical electrical structures; studies on new electronic operating principles; development of progressive methods and processes of micro-structuring; elucidation of strata separation of materials behavior in the component technology as well as mechanical-chemical crystal processing.

PHOTO CAPTIONS

1. p 19. Institute for Semiconductor Physics in Frankfurt (Oder).
2. p 20. The use of electron-lithograph equipment is a crucial prerequisite for the production of microelectronic structures less than $1\mu\text{m}$. The illustration: Adjustment of the scanning electron microscope ZRM 112 of the Jena Carl Zeiss VEB for measuring a structure lit by an electron ray (see also illustration at bottom of p 11).
- 3,4. p 21. Taper sectioning photograph of the surface zone of a structured silicon disk before and after intrinsic gettering (depth of the defect-weakened zone about $10\text{-}20\mu\text{m}$).
5. p 22. Evaluation of a test field prepared in cycle 1 by the automatic multiple probe tester AVT 110.

11698
CSO: 2302/37

END