

201181

JPRS+ESA-84-015

22 May 1984

# East Europe Report

SCIENCE & TECHNOLOGY

DISTRIBUTION STATEMENT A

Approved for public release;  
Distribution Unlimited

19980501 044

DTIC QUALITY INSPECTED 3

**FBIS**

FOREIGN BROADCAST INFORMATION SERVICE

REPRODUCED BY  
NATIONAL TECHNICAL  
INFORMATION SERVICE  
U.S. DEPARTMENT OF COMMERCE  
SPRINGFIELD, VA. 22161

5  
49  
A63

#### NOTE

JPRS publications contain information primarily from foreign newspapers, periodicals and books, but also from news agency transmissions and broadcasts. Materials from foreign-language sources are translated; those from English-language sources are transcribed or reprinted, with the original phrasing and other characteristics retained.

Headlines, editorial reports, and material enclosed in brackets [ ] are supplied by JPRS. Processing indicators such as [Text] or [Excerpt] in the first line of each item, or following the last line of a brief, indicate how the original information was processed. Where no processing indicator is given, the information was summarized or extracted.

Unfamiliar names rendered phonetically or transliterated are enclosed in parentheses. Words or names preceded by a question mark and enclosed in parentheses were not clear in the original but have been supplied as appropriate in context. Other unattributed parenthetical notes within the body of an item originate with the source. Times within items are as given by source.

The contents of this publication in no way represent the policies, views or attitudes of the U.S. Government.

#### PROCUREMENT OF PUBLICATIONS

JPRS publications may be ordered from the National Technical Information Service, Springfield, Virginia 22161. In ordering, it is recommended that the JPRS number, title, date and author, if applicable, of publication be cited.

Current JPRS publications are announced in Government Reports Announcements issued semi-monthly by the National Technical Information Service, and are listed in the Monthly Catalog of U.S. Government Publications issued by the Superintendent of Documents, U.S. Government Printing Office, Washington, D.C. 20402.

Correspondence pertaining to matters other than procurement may be addressed to Joint Publications Research Service, 1000 North Glebe Road, Arlington, Virginia 22201.

22 May 1984

EAST EUROPE REPORT  
SCIENCE & TECHNOLOGY  
CONTENTS

GERMAN DEMOCRATIC REPUBLIC

- New Home Computer Z 9001 Developed  
(RADIO FERNSEHEN ELEKTRONIK, No 3, Mar 84; SAECHSISCHE  
ZEITUNG, 8 Mar 84)..... 1
- Detailed Description, by Bernd Schindler  
Uses Outlined
- Unified Effort To Expand Biotechnology Research  
(IWE TAGESDIENST, No 52, 6 Apr 84; FREIHEIT, 30 Mar 84).... 10
- West German Commentary  
Experts Interviewed

HUNGARY

- Inauguration of IC Production Line  
(NEPSZABADSAG, 20 Apr 84)..... 13

POLAND

- Recent Computer Development, Application Described  
(Various sources, various dates)..... 14
- Microcomputer PSPD 90-PI System, by Kazimierz Lal,  
Marian Mroczka  
New Microcomputer Systems  
Ryad System Applications  
Emulator Application for R-32 Computer, by Krzysztof  
Perycz  
Meritum-1 Home Computer

|  |    |
|--|----|
| Solutions to Science-Technology-Economy Triangle Stressed<br>(RZECZPOSPOLITA, 7 Mar 84; PRZEGLAD TECHNICZY, No 10,<br>4 Mar 84).....   | 25 |
| Uniform System, Policy Required<br>Problems, Solutions Discussed, by Witold Ochremiak  |    |
| Development, Control of Science Assessed<br>(Various sources, various dates).....  | 34 |
| Basic Research Stressed, by Witold Blachowicz<br>Research-Development Trends Outlined, by Tomasz Miecik<br>Scientific Organization, Control Criticized, by<br>Stanislaw Lojewski |    |

NEW HOME COMPUTER Z 9001 DEVELOPED

Detailed Description

East Berlin RADIO FERNSEHEN ELEKTRONIK in German Vol 33 No 3, Mar 84 pp 148-149

[Report by Bernd Schindler, VEB ROBOTRON Center for Research and Technology]

[Text] The home computer Z 9001 for the first time offered to the GDR population a consumer article which makes accessible to every individual, in a simple and uncomplicated fashion, the manifold applications offered by microelectronics and microcomputer technology. The unit is distinguished by uncomplicated programming and by meaningful expansion capabilities. It is presented in this paper.

The home computer Z 9001 was developed in collaboration between the VEB Robotron Measurement Electronics "Otto Schoen" Dresden and VEB Robotron ZFT (Central Office for Research and Technology). It is a high-grade technical consumer article based on modern microcomputer technology. It was designed so that it is easy to learn and handle. The home computer offers to everyone, who is interested in the use of microcomputer technology, an unlimited field of meaningful applications for school, profession, hobby, entertainment, education, and training.

Applications

The home computer Z 9001 can be used very effectively to support the teaching and learning process in schools, colleges, and other vocational and training institutions. For instance: to image laws and development processes in nearly all technical areas, as a means to check the state of knowledge, or as an instrument to perform scientific-technical calculations.

In the home area, the computer offers game and entertainment capabilities for all age groups. Different computer games demand different capacities on the part of the player, for example, reaction ability in the case of reaction and skill games, or logical thinking and the recognition of relationships in strategy and logic games.

Besides pure entertainment, there are also other useful applications, such as setting up files to manage budgets, to keep an index of addresses or telephone numbers, or to construct tables and evaluate them statistically.

Because of its connection and expansion capabilities, the computer offers to the electronic hobbyist and naturally also to the expert many opportunities to control and regulate home-built technical equipment in the home area. In the technical area it can be used, for example, to calculate the heat required in private homes, to calculate electronic modules such as RC-filters and the like. It also can be used like a freely programmable desk-top computer.

### Equipment and Expansion Capabilities

The Z 9001 home computer is a compact unit with a typewriter keyboard. The basic equipment furthermore comprises two control levers which are used especially in connection with various games, an audio-tape cassette and an operating manual. In addition, plug-in and expansion modules can be procured, which enhance the performance capability and the application capabilities of the home computer.

A commercial TV unit is connected to the home computer through the antenna receptacle (channel 3), and a standard cassette recorder is connected through a diode cable.

Figure 1 shows the structure of the computer with its peripheral units. The TV unit is used to represent information.

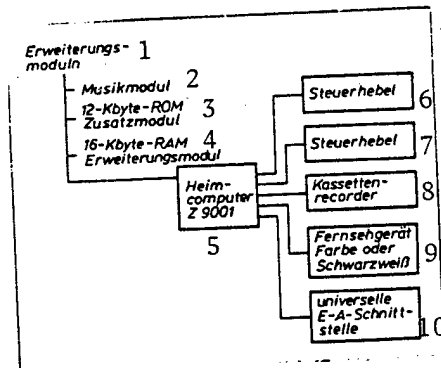

Figure 1: Peripherals for the home computer

Key:

1. Expansion modules
2. Music module
3. 12 kbyte ROM
4. 16 kbyte RAM expansion module
5. Home Computer Z9001
6. Control lever
7. Control lever
8. Cassette recorder
9. Television unit, color or black and white
10. Universal I/O interface

The programs delivered by the manufacturer are written into the computer by means of the cassette recorder. Also, programs and files generated by the user himself can be stored in this way.

For users who are quite knowledgeable about the internal structure of the home computer and about microcomputer technology and its programming, there is a user-specific input and output interface and the computer bus for individual use. The manual, which is supplied together with the computer, makes it possible for the user to acquire the knowledge necessary for independent programming. The home computer can be programmed in the machine code of the U880 microprocessor system, in the Basic programming language or in Assembler language.

The powerful Basic interpreter and the Assembler packet are furnished on a compact cassette, but they could also be acquired by the user as ROM expansion modules.

The Z 9001 home computer consists of the following functional groups: computer board, keyboard, and power supply. This basic unit can be built up by the following supplementary modules:

- 12 kbyte ROM supplementary module
- 16 kbyte RAM expansion module
- music output module
- supplementary color module

Figure 2 shows the basic circuitry.

#### Computer Board

The computer board houses the microprocessor system U880D with a memory and with input and output interfaces.

The microprocessor is connected via an internal computer bus to the internal RAM, the ROM, the U857D, as well as two PIOs U855D.

The read-only-memory has a capacity of 4 kbytes and contains the operating system; a dynamical memory with 16 kbytes storage capacity is used for the write-read memory. Of this, 0.5 kbytes are reserved as system memory. The rest is available to the user.

An input and output module U855D (PIO) is used for keyboard activation. The second PIO places the D channel completely on the I-O receptacle and is available to the user. Channel A is used to implement the following functions:

Activation of an LED on the keyboard to indicate the graphic mode (1 bit)

Enabling the acoustic signal generator on the keyboard (1 bit)

Programming the color for the margin of the video screen (3 bits)

Programming the video operating mode (20 lines or 24 lines (1 bit)

Implementing the input from the cassette recorder (2 bits)

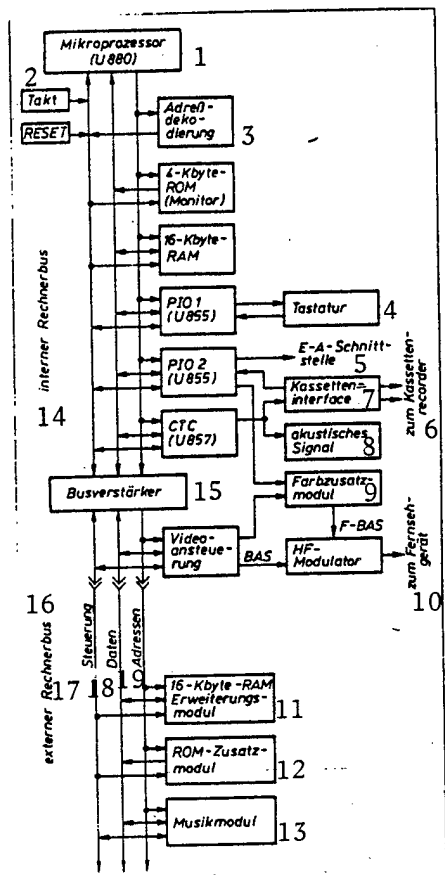

Figure 2: Basic circuit diagram of the home computer

Key:

1. Microprocessor (U880)
2. Clock pulse
3. Address decoding
4. Keyboard
5. I/O interface
6. To the cassette recorder
7. Cassette interface
8. Acoustic signal
9. Supplementary color module
10. To the television unit
11. 16 kbyte RAM expansion module
12. ROM supplementary module
13. Music module
14. Internal computer bus
15. Bus amplifier
16. External computer bus
17. Control
18. Data
19. Addresses

Out of the four channels of the counter-timer module U857D (CTC), one channel is placed on the I-O socket and is available to the user, another channel is used to activate the acoustic signal generator and for output on the cassette memory. The remaining two channels form the system clock.

The address decoding unit, which is connected to the internal bus, forms the selection signals for the I-O components, as well as for the memory modules and the picture refresh memory. Furthermore, the address decoding controls the bus amplifiers, which form the external computer bus, from the internal computer bus. The video activation unit is connected to the external computer bus. The external computer bus is also conducted to the expansion plug connectors, by means of which the supplementary modules of the home computer are connected.

The video drive consists of the picture refresh memory with one kbyte memory capacity, a character generator to represent 256 characters, and a synchronization block to form the synchronization and scanning signals. The BAS signal is generated here and is converted in the modulator into an HF signal. It can be fed into the antenna socket of the television unit.

The characters are shown on the video screen in a matrix of 8x8 points.

As regards the video screen display, one can choose between a graphic mode and a text mode. In the text mode, the line spacing has been enlarged by two points to make the text more readable.

The homecomputer can be optionally equipped with a SECAM supplementary color module. For this purpose, the necessary signals are conducted to a special plug connector. The supplementary color module delivers the FBAS signal instead of the BAS signal, which is then conducted to the modulator.

The color attribute memory of the supplementary color module has a storage capacity of one kbyte. There the information about foreground and background color is written for each character on the screen. Eight colors are available: white, red, blue, green, cyan, violet, yellow, and black.

After the device has been switched on, the reset logic delivers a pulse of about 20ms, which puts the home computer into its base state. A reset pulse lasting ten  $\mu$ s. is generated through the RESET key on the keyboard. Thus, the home computer can be put into its base state without destroying the memory content. The quartz-controlled clock pulse generator generates a basic cycle of 9.8304 MHz. From this, two dividers form the system clock pulse of 2.4576 MHz. The video drive generates from the basic clock pulse the pulse frequency of 7.3728 MHz which it requires.

#### Keyboard

The keyboard consists of 64 keys with numbers, letters, special characters, and control keys, in a typewriter-like arrangement. Furthermore, an acoustic signal generator and two LED's are located there, which are used to indicate the operating voltage and the graphic mode.

The keyboard operates on the basis of elastomer rubber mats. A gold-plated contact prong is situated beneath each key. These prongs are connected to the input and output module by way of an 8x8 matrix. Upon each key depression, the contact rubber short-circuits the corresponding prong, the computer determines the depressed key, and executes the operation corresponding to the key.

### Power Supply

The home computer uses a blocking transformer power supply which provides output voltages of 12V, 5V, and minus 5V. The power supply is protected against electric overloads.

The most important technical data are summarized in the table.

Some technical data:

#### Basic Unit

|                                       |  |
|---------------------------------------|--|
| Processor type                        | U880D  |
| Memory capacity                       | 4 kbyte RAM (operating system) 16kbyte RAM (user memory) 1 kbyte RAM (picture refresh memory)  |
| Memory expansion                      | to max. 64 kbyte by supplementary ROM or RAM modules.  |
| Keyboard                              | Elastomer keyboard with a typewriter-like arrangement integrated into the unit.  |
| Display unit                          | Black and white or color television unit connectible through the antenna input (Channel 3)   |
| Image structure                       | 24 lines X 40 characters per line (graphic mode)<br>20 lines X 40 characters (text mode)   |
| Character inventory                   | 96 text characters (large and small letters, numbers, special characters)<br>128 graphic symbols for quasi-graphic display   |
| Mass memory cassette recorder         | Audio output for acoustic signalling (can be switched off)   |
| Connection and expansion capabilities | One diode socket for the cassette audio tape unit, one HF socket for a television unit, two sockets for control levers to implement various video games, one input and output socket for user-specific I-O wishes (one channel each of the U855 and of the U857) |

can be programmed by user), four supplementary modules, one integrated plug connector for connecting the color expansion module.

|  |  |
|--|--|
| Programming languages                      | Basic, Assembler language  |
| Power Supply                               | 220V $\pm$ 10V, 50Hz   |
| Current consumption                        | about 0.15A  |
| Protection level                           | IP20, TGL, RGW 778   |
| Protection class                           | II TGL 21366   |
| Dimensions in mm                           | 400 X 300 X 80   |
| Weight                                     | About 5kg  |
| Supplementary modules                      |  |
| Dimensions in mm                           | each 112.5 x 100 x 19.5  |
| -12 kbyte ROM supplementary module         | contains the basic interpreter or user programs  |
| -supplementary module with plug-in sockets | gives the user the capability of using ROMs that he has programmed himself   |
| -16 kbyte RAM expansion module             | to extend the working storage in 16 kbyte steps  |
| -music output module                       | the audio level, sound coloration, and tone envelope can be programmed   |
| -supplementary color module                | 1 kbyte color attribute memory, permits the display of eight colors on the color video screen. The colors for the screen margin, the character background, the character foreground can be programmed. |

The modules are connected to the system bus; only a supplementary color module is connected via a special internal plug connector in the unit.

#### Operation

If the home computer is connected with a television unit and a cassette recorder, and if it is switched on, it is immediately ready to operate. An LED indicates this state.

Upon switch-on a RESET signal is formed and the home computer is placed into its base state, i.e., it transfers to the operating system (monitor program).

The home computer then indicates its ready status on the TV screen, and waits for the user to input a command. The user now has the possibility, among other things, of reading and writing arbitrary memory cells by entering commands through the keyboard, of entering programs in machine code, starting such programs, reading programs in from the cassette memory, or writing on the cassette. Every wrong input is rejected by the home computer by outputting a question mark on the video screen, and a new command input is requested. After the home computer is switched on, the program selected by the user is read in the compact cassette, as the standard case. After this operation has been successfully concluded, the computer transfers into the user program.

Every further communication between the computer and the user now takes place in dependence on the particular user program.

#### Uses Outlined

Dresden SAECHSISCHE ZEITUNG in German 8 Mar 84 p 3

#### [Unattributed article]

[Text] By the 34th anniversary of the GDR, the first 100 home computers Z9901 will be produced and delivered by the VEB Robotron Measurement Electronics "Otto Schoen" in Dresden. This represents a one year gain in time compared to conventional development sequences. In 1984, a total of 500 units are to be produced. In 1985, this high-demand consumer article will then be mass produced. This will implement a significant youth object of the Robotron Combine. Already at the Central Exhibition of Tomorrow's Masters, last year, the prototype of the Robotron home computer received a special prize from the ministerial council, from the FDJ (Free German Youth) Central Council, and the FDGB (Free German Labor Union Federation) Federal Board.

The major portion of this development came from a youth research collective of the Center for Research and Technology (ZFT) of the Robotron Combine, which comprises 22 scientists, engineers and experienced designers. At the present time, the device is being developed and is being prepared for transfer into production in close socialist collaboration between the Robotron Enterprises ZFT and Measurement Electronics. The home computer consists of the basic unit with a keyboard and two game levers. It can be coupled with any commercial television unit - a color variant is also possible - for picture output, and with any magnetic tape unit (recorder) as a mass memory. Supplementary modules are also provided, e.g. working memories and read-only memories, that is memories which can be erased immediately but also can accept fixed, permanent programs, as well as a music module connection by means of which electronic music can be produced. Connection capabilities are also provided for other peripheral units, for example, printers or electronic typewriters.

The new home computer from Dresden offers very extensive use and application capabilities. It can be operated meaningfully and creatively step by step by students. But it likewise is a valuable tool for scientific activities, saving labor and routine work. The programs for computer games are useful for training in logical thinking, for testing reaction power and skill, and for entertainment. They can simulate about 35 creative games, e.g. including board or card games. Another area are control programs for hobbies, home and profession. Thus, for example, a complete model train system can be controlled and a track diagram can be simulated on the video screen. Heating systems (aquariums or greenhouses) could also be controlled fully automatically by the computer if the necessary measured values are entered. In the future the appropriate supplementary devices for this will also be offered by the Dresden enterprise. For experimental and scientific work, the computer - since it is freely programmable - can control measurement sequences, e.g. in physical or chemical tests and experiments.

Its application area for instruction and teaching is extensive. Here, teaching, learning, and testing programs are deployed as necessary. Thus, both high school students and college students can learn with the computer and test their knowledge. For this reason, the computer is also intended for use in schools and educational institutions. Finally, the home computer makes it possible to gain familiarity with modern electronic data processing and computer technology and their effective applications. Step by step, the user learns to operate and program the computer and thus the home computer can function more and more as a productive helper. For example, the scientist, engineer, or technician can store important routine tasks and data. The historian may possibly secure rapid access to important data and facts. The home computer can solve mathematical problems far beyond the ability of pocket calculators. It can also save a great deal of time in connection with laborious recurrent work involving calculations or statistics. Home computers thus are a consumer article as well as a means for working and learning. Demand for them is increasing faster and faster, and the Dresden Measurement electronic engineers want to take account of this demand by their work.

8348

CSO: 2302/38

UNIFIED EFFORT TO EXPAND BIOTECHNOLOGY RESEARCH

West German Commentary

West Berlin IWE TAGESDIENST in German No 52, 6 Apr 84 p 1

/Text/ The GDR is presently making a big effort to push research in the field of biotechnology. For example, research centers are being established and scientific capacities from various disciplines are being combined. The Institute of Industrial Chemistry of the Academy of Sciences has been reorganized and oriented toward biotechnology. In this way, the GDR wants to create a scientific head start for the brisk development of the microbiological industry whose main products are to be fodder albumin, antibiotics, and enzymes.

During an interview with the SED journal FREIHEIT, which is published in Halle, experts described biotechnology as a "key technology." They believe that it could "create new possibilities for contributing to the national economy's output increase through more effective production methods, especially through a high degree of refinement of domestic raw materials." It is, they maintained, already possible "by using an organic active substance to employ unmalted barley in brewing beer and thus to save an entire processing step." At the same time it makes it possible "to process byproducts or waste products which have not been utilized until now." It thus finally contributes to reducing environmental pollution. For example, sulfite waste liquor--a waste substance derived from the cellulose industry--is reportedly turned into valuable fodder albumin by means of biotechnological methods. Attempts are being made to utilize agricultural production waste as well as community waste water and refuse as raw materials for microbial biomass production. The experts expressed the opinion that about one-third of the substance conversion process could be influenced through biotechnology, that is to say, it could be made more effective.

Experts Interviewed

Halle FREIHEIT in German 30 Mar 84 p 11

/Interview with Rector Prof. Rolf Schulze, Prof. Heinz Weide, Technical University at Koethen; Prof. Horst Wolffgramm, Martin Luther University, Chairman, Engineering Sciences Division, Urania; Dr. Dieter Warnecke, Deputy Director for Research, Bitterfeld Chemical Combine; Dr. Karl-Heinz Foerster, Scientific-Technical Center for Pumps and Compressors, Chairman,

Engineering Sciences (Bezirk) Division, Urania, by Hans-Juergen Greye and Juergen Boehme. Discussion was part of the 22nd URANIA Discussion; date and place not specified./

Excerpt FREIHEIT: What can biotechnology accomplish here?

Dr Foerster: Biotechnology can create new possibilities for contributing to an increase in the national economy's output through more effective production methods, especially through a higher level of refinement of domestic raw materials. It is already possible, by using an organic agent, to employ unmalted barley for beer brewing and thus to skip an entire processing phase. Biotechnology can at the same time create solutions for processing byproducts or waste products which have not been used until now. It thus in the final analysis also contributes to relieving the burden on our natural environment. For example, sulfite waste liquor is made into valuable fodder albumin by biotechnological means. Attempts are also being made to utilize agricultural production waste (for example, liquid manure, straw), as well as community waste water and refuse (garbage) as raw materials for microbial biomass production. This is where environmental protection and the exploration of completely undreamed-of raw material sources are combined in a particularly clear fashion.

Professor Schulze: Like microelectronics, biotechnology is a key technology in a highly developed national economy such as ours. But you cannot compare those two. The radius of effectiveness of biotechnology is narrower and especially encompasses substance and materials management. There is an incipient development trend to the effect that about one-third of the substance conversion processes can be influenced by biotechnology, that is to say, can be rendered more effective.

Professor Weide: The fact is that biotechnological production will always take place in the "competition" with the chemical industry. There is therefore no area which biotechnology could "lease" because effectiveness is always the decisive factor. This is why this third is not a static ratio but a possible one. That also results from the special features of biotechnological production.

FREIHEIT: What are those special features?

Professor Schulze: While chemistry works with dead substances, we are dealing here with living organisms which as a rule need oxygen and of course nutrients. In production one must above all make sure that the organisms will not be killed by the toxins. You need sterile work methods and that, again, creates high requirements for the instruments. On top of that we have the fact that most products are used as fodder, essential foods, pharmaceuticals, or biochemicals in areas where special safety regulations must be complied with, such as the food law.

Professor Wolffgramm: Biotic systems are highly sensitive and are viable only in a narrowly limited environment. This is why biotechnology must consider such decisions as the organism encounters in its natural environment and which it needs for its growth. If certain boundaries are exceeded in terms of temperature, oxygen concentration, etc., then the micro-organism will produce ineffectively or may even die.

**FREIHEIT:** What does that mean in terms of requirements for the production plants?

**Dr Foerster:** Our conventional technology can be used only to a limited extent here. We need machinery, instruments, and equipment which will meet the specific requirements, for example, regarding sterility. New requirements arise as far as separation technique is concerned because all products are found finely distributed in a liquid and must be separated from it. Drying technique is therefore also facing higher-level tasks. Finally we need special measurement and automation equipment--such as new measurement sensors which can determine the oxygen potential and other values in a continuing flow.

**Dr Warnecke:** The biggest efforts in the development of biotechnology must undoubtedly be made by research--both in the engineering and in the natural-science fields.

**Professor Wolffgramm:** To guarantee the scientific head start, we are already establishing research centers and we are combining the intellectual capacities from various disciplines. For example, the Institute of Industrial Chemistry of the Academy of Sciences was reorganized and oriented toward biotechnology.

**FREIHEIT:** What steps are being made along these lines in Halle Bezirk?

**Professor Schulze:** Our colleges bear a high degree of responsibility here, both in terms of education and regarding the concentration of research efforts. Under the guidance of the bezirk party organization, we are in particular working toward the cooperation of the various installations because this is where we have a prerequisite for good results. This cooperation has already begun through joint conferences at the Martin Luther University at Halle and the Koethen Engineering College, through consultations by the scientific councils, as well as coordination in research programs.

**Dr Warnecke:** This of course also includes combines and enterprises, such as the Bitterfeld Chemical Combine or the Halle VEB Ingenieurtechnik because all research is from the very beginning geared toward taking effect in practice very quickly.

**FREIHEIT:** What level did biotechnology reach on an international scale?

**Professor Wolffgramm:** Development began only during the last decade on a worldwide scale. In most industrial countries, for example, in the Soviet Union, in the United States, Japan, the FRG, and France, government development programs are currently being drafted or are already in existence--but all of them are only at the beginning. We started out simultaneously with those countries and we thus have good prerequisites for keeping up successfully.

**Professor Schulze:** In the GDR we face the task of further expanding the microbiological industry with its main products of fodder albumin, antibiotics, and enzymes. Here we must above all considerably increase the utilization of domestic raw materials and secondary raw materials above all through new technologies. That was resolved at the Tenth SED Congress and this is being carried out in a goal-oriented manner.

HUNGARY

INAUGURATION OF IC PRODUCTION LINE

Budapest NEPSZABADSAG in Hungarian 20 Apr 84 p 5

[Excerpts] The complete production line for fabrication of ICs was officially inaugurated on 19 April at the Ujpest factory of the Microelectronics Enterprise [Mikroelektronikai Vallalat]. The equipment was delivered by the Soviet Union which also sold the technological license to the Hungarian electronics industry. Alekszandr Sokin, minister of Soviet electronic industry, stressed that the Soviet partner had delivered state of the art technology and manufacturing procedures to Hungary thereby enabling the Hungarian electronics industry to develop more rapidly than in the past.

Mihaly Sandory, government commissioner and executive director of the enterprise, said that over 100,000 persons were employed in this branch of industry and that the electronics plants produce one quarter of all machine industry products. Half of some of the products manufactured are sold abroad. Output of the electronics industry is expected to increase by 8-9 percent in the coming years.

CSO: 2502/54

## RECENT COMPUTER DEVELOPMENT, APPLICATION DESCRIBED

## Microcomputer PSPD 90-PI System

Warsaw POMIARY AUTOMATYKA KONTROLA in Polish No 1, Jan 84 pp 18-20

[Article by Kazimierz Lal and Marian Mrocza, Staff of the Institute of Automatics and Metrology, and Automation and Informatics Institute of Rzeszow Polytechnic: "Microcomputer System PSDP 90-PI"]

[Text] A microcomputer system based on domestic series produced elements is described. The system is capable of performing the instructions of the CRD and DDC systems and has a higher operational speed and lower incidence of failures than systems based on the Mera 300 microcomputer series. The system is compatible with the microprocessor controllers PI80 (PIM) and SK-102 and allows preparing and testing programs for these units without application of interfacing compilers.

In domestic industry and power production, combinations of minicomputer assemblies Mera 306 (305) with Inteldigit interface are commonly used for centralized data registration systems CRD. The central component of these systems, developed in the 1970's, has mediocre operational parameters. It features a low processing capacity, large size and a high failure rate. Presently, a modern microcomputer PSPD 90 is being produced, based on the Intel 8080A microprocessor. It is the so-called data-processing station manufactured by Mera-KFAP Enterprises.

The Automation and Informatics Institute of Rzeszow Polytechnic has attempted to adapt this microcomputer to operate with the PI interface and function in an on-line mode. After a study of various possibilities, it has been determined that the unit should be compatible with the commonly used system based on the Mera 306 (305) minicomputer, which can easily be produced with a maximum degree of utilization of serially manufactured domestic components.

These principles determine the structure of connections in the system (Fig. 1). In contrast to the classical connection--computer-coupling block-interface-object--an additional element has been introduced, the so-called

interface adapter. This apparent complication of the connection allowed using mass-produced coupling block BS 02 for connection with the Mera 305 in the new system. The interface adapter is a relatively simple digital device based on domestically produced elements of the TTL series. It adapts information and control signals from the PSPD 90 to a form acceptable by the BS 02 and vice versa (Fig. 2).

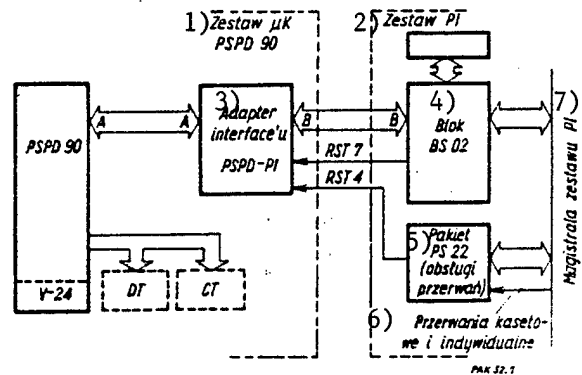

Figure 1. Connection of PSPD microcomputer to PI interface.

- |                                  |  |
|----------------------------------|--|
| 1. Microcomputer system PSDP 90  | 5. Software package PS 22 (interrupt services) |
| 2. PI system                     | 6. Package and individual interrupts           |
| 3. Interface adapter for PSDP-PI | 7. Main line of PI system                      |
| 4. Block BS 02                   |  |

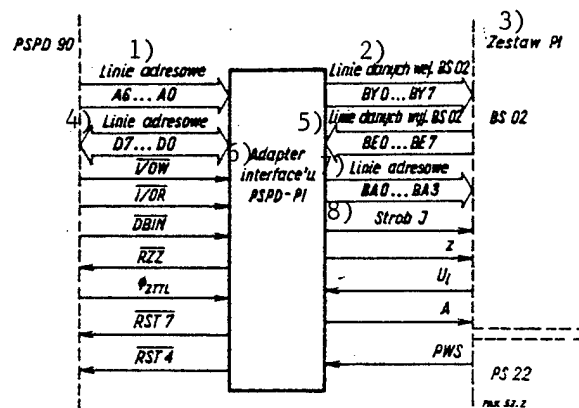

Figure 2. Connection of interface adapter with PSDP 90 and PI

- |                     |                              |
|---------------------|------------------------------|
| 1. Address lines    | 5. Output data lines         |
| 2. Input data lines | 6. Interface adapter PSDP-PI |
| 3. PI system        | 7. Address lines             |
| 4. Address lines    | 8. Strobe J                  |

The adapter performs the following functions:

--decodes the group address of input-output terminals intended for service of the interface;

--connects two-line data channel D7...D0 of the microcomputer with two unidirectional lines BY0...BY7 of the input type and BE0...BE7, output type;

--processes the transmission direction signal A and strobe signal J on the basis of control signals:  $\bar{\Phi}$ , TTL, DBIN, I/OW and I/OR; and

--operates as a mediator in transmitting the interrupt signals PWS from the interface through the medium of the PS 22 package and the interrupt signal from the BS 02 U<sub>j</sub> block.

In this fashion, the central unit PSPD 90 through the medium of interface adapter and BS 02 block can supervise the operation of a set of implementation software Inteldigit PI, realizing the direct connection with the industrial object concerned.

The PSPD 90 microcomputer has a display screen monitor, alphanumeric keyboard, character matrix printer DZM-180, four memory units on floppy discs and V-24 interface. In addition, it is connected to a DT105 tape printer and CT2100 tape reader.

#### Joint Operation Between the PSPD 90 and PI

The joint operation of the microcomputer with the PI interface can be initiated either by microprocessor or by the PI. In the former case, this is activated by the program being implemented. In the latter, the joint operation is initiated by interrupts generated by the PI interface.

#### Communication of the Microcomputer with PI

The interface adapter subordinates (see table) to instructions IN<sub>xx</sub>/OUT<sub>xx</sub> of the Intel 8080 microprocessor the instructions WW<sub>xx</sub> of the Mera 300 accepted by the coupling block BS 02. The instruction sequences for recording/reading to/from the interface PI are of equivalent importance (in terms of heirarchy specified in the table) with the communication directions from the Mera 300-PI [5].

For facilitating the programmed communication with the PI interface, an additional RST procedure has been added to the operational system of the PSPD 90 which performs registration and reading from the PI. Before calling RST, it is necessary to place in the universal locations of the BC microprocessor the data on the code of the function, the cassette address and the package address. After performance of RST, the microprocessor accumulator contains data on correctness of communication or cause of error. After completing the operation of reading from the PI, the resulting data are placed in the location DE of the microprocessor.

Table. Corresponding Instructions in Communication between PSPD 90 and Mera 300 and PI

| <u>PSPD 90-PI</u> | <u>Mera 300-PI</u> | <u>Meaning</u>                |
|-------------------|--------------------|-------------------------------|
| IN 24H            | WW04               | Readout R08-R15<br>or SSBS 02 |
| IN 25H            | WW05               | Readout R00-R07               |
| OUT 24H           | WW24               | Record W08-W15                |
| OUT 25H           | WW25               | Record W00-W07                |
| OUT 26H           | WW26               | Record F0-F7                  |
| OUT 27H           | WW27               | Record AK0-AK15 APO-AP15      |

#### Communication between the PI and the Microcomputer

The interface PI may request communication with the microcomputer by sending interrupt signals.

The PSPD 90-PI system is furnished with a two-level interrupt system. The first level interrupts are generated by the coupling BS 02 block in case of breakdown of the PI interface.

The BS 02 block, after establishing: uncoupling of PI unit, connection of PI unit, engagement or absence of an addressed package or transmission error, sends out  $U_i$  signal on the basis of which the interface adapter generates interrupt RST 7 of the microprocessor. The sources of the  $U_i$  signal are memorized in the "status word" of the BS 02 block (SSBS 02). The algorithm of a typical program of interrupt service RST 7 reflecting the typical time dependencies between the state of the signal  $U_i$  and the contents of SSBS 02 are illustrated by Fig. 3.

Interrupts at the second level are generated by the internal interrupt PS 22 package and occur during the course of normal operation of packages and cassette controls [6].

The PS 22 package, after determining the appearance of signals (maximum 8) in the interrupt channel of the PI, memorizes them in the register and outputs a summary signal PWS; on the basis of this signal, the interface adapter generates the RST 4 interrupt of the microprocessor. The service of the RST 4 interrupt is based on reading the contents of the PS 22 register and calling the subroutine (subroutines) serving the individual causes of the PWS signal. The block diagram of a typical service program of RST 4 interrupts is shown in Fig. 4.

This system has several merits. First, it fills a gap that is caused by the discontinuance of production of the Mera 300-PI equipment. In addition, the PSPD 90-PI system is less expensive and, according to experimental tests, has a faster operation and lower error rate.

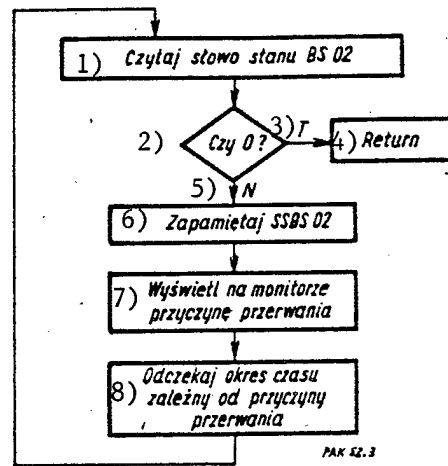

Figure 3. Block-diagram of the RST 7 interrupt service.

- |                              |  |
|------------------------------|--|
| 1. Read status word of BS 02 | 5. No  |
| 2. Is it 0?                  | 6. Memorize SSBS 02                            |
| 3. Yes                       | 7. Display on screen cause of interrupt        |
| 4. Return.                   | 8. Wait sufficient time as per interrupt cause |

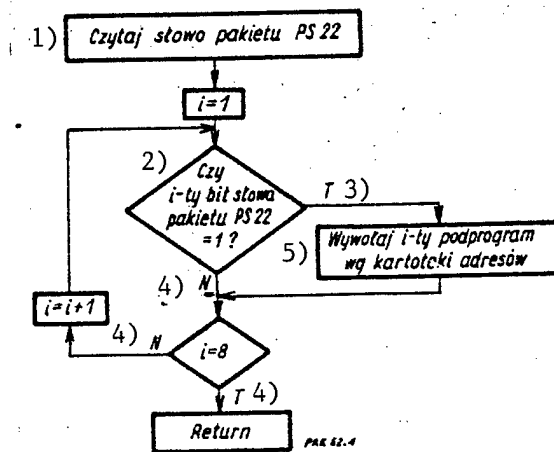

Figure 4. Block-diagram of the RST interrupt service.

- |   |   |
|---|---|
| 1. Read word of package PS 22                       | 3. Yes  |
| 2. The $i$ th bit of the word of package PS 22 = 1? | 4. No   |
|   | 5. Call $i$ th subroutine as per address file |

Secondly, it is compatible with the Inteldigit PI and the SK-102 (the same microprocessor and interface) controllers and can be used for generating and testing (!) programs for these systems, including the paper tape punching for memory programmers.

Thirdly, it is furnished with a V-24 connection and can operate in heirarchical systems as the main computer (such as for the SK-102) or as a peripheral device (for instance, to the Mera 400).

Using the PSPD 90-PI system described above, where the operational PSPD 90 system has been enlarged to include the interrupt service programs and procedures for connection with the PI described in the article, prototype CRD and DDC systems have been built at the Institute of Automation and Informatics of Rzeszow Polytechnic. The CRD system serves for measurement and registration of data in real-time studies of physiologic parameters in patients and is being currently introduced into practice at the Medical Academy in Krakow. The DDC system is a multichannel digital regulator used at the laboratory of control systems of Rzeszow Polytechnic. The system also is used for development and testing of software for the control unit Inteldigit PI to be used at the Zapel Electronics Porcelain Factory in Boguchwala.

#### BIBLIOGRAPHY

1. Badzmirowki, K., Pienkos, J. and Piestrzynski, W., "Systemy mikroprocesorowe" [Microprocessor Systems], Warsaw, WNT, 1981.
2. Grabowski, J. and Kosiacz, S., "Podstawy i praktyka programowania mikroprocesorow" [Principles and Practices of Microprocessor Programming], Warsaw, WNT, 1980.
3. Klingman, E.E., "Projektowanie systemow mikroprocesorowych" [Design of Microprocessor Systems], Warsaw, WNT, 1982.
4. Orłowski, H., "Komputerowe układy automatyki" [Computer Automation Systems], Warsaw, WNT, 1980.
5. "DTR Blok sprzęgający BS 02" [DTR Coupling Block BS 02], Warsaw, PIAP, 1979.
6. "DTR Pakiet przerwan wewnętrznych PS 22" [Internal Interrupt Package PS 22 for the DTR], Warsaw, PIAP, 1979.

#### New Microcomputer Systems

Warsaw INFORMATYKA in Polish No 1, Jan 84 p 25

[Article: "Novelties in Computer Equipment"]

[Text] Under the aegis of the Sixth Silesian Organization Days, an exhibition of mini- and microcomputers took place on 11-13 October 1983 in Katowice. Major producers of equipment currently available in Poland took part in this event. The noteworthy exhibits included:

● VT 20/IV Minicomputer system presented by the Hungarian firm Videoton. The system is of a qualitatively different variety from the technical solutions with which we are familiar. It consists of four local processors working in combination with terminals of the NDN 52500 type and keyboards and the input-output processor that serves large-scale memory and printers. The local processors (terminals) are based on the Z-80A microprocessors with ROM 1 kB and RAM 4 kB memories. The input-output processor is built also on the Z80-A microprocessor with ROM 6 kB and RAM 64 kB memories and communicates with the environment through DMA channels and asynchronous connections V-24. Channels of the DMA type allow coupling up to eight disc units with a capacity of 5-50 MB and a printer with a speed of 300 to 1200 lines/min. The system is furnished with COBOL, BASIC, FORTRAN and PASCAL translators. The input-output processor is provided with a simple data base management system. The data are transmitted with the use of an instructional language.

● MP Microcomputer was presented by the Polish producer, Mera-KFAP. The microcomputer is based on designs developed by the Polonia Company Impol. The system consists of a processor module with 64 kB memory, a screen monitor based on a Neptun television set, a keyboard, one or two floppy disc units and a matrix printer (D-100 or D-200). The system is adapted for joint operation with the CP/M system and is supplied complete with BASIC compilers. It is intended for users at research institutes and design bureaus, mainly in view of its small size, easy assembly and low cost.

● The Meritum I microcomputer was presented by Mera-Elzab Enterprises. Patterned on popular world concepts, it is based on the Z-80 microprocessor and available, domestically produced elements. The computer has a 14 kB ROM memory (intended for use in BASIC language) and a 16 kB RAM memory, systems for connection of a printer, control of cassette tape recorder (as external memory) and control of standard TV receiver serving for display of texts. The microcomputer is furnished with an expanded version of the BASIC language. The producer envisages further development of this system, which is to be expanded to include systems for mass scale memory, services on floppy discs and a color television display screen.

Other exhibits included the Robotron 5120, Mera 60 and Elwro 5/3 systems, known already from earlier exhibitions (including those at Poznan Fair), and utility programming systems of personal microcomputer of the ZX81 type offered by Nowatech Enterprises.

#### Ryad System Applications

Warsaw INFORMATYKA in Polish No 1, Jan 84 p 25

[Information Brief: "Information Exchange"]

[Text] Step-Baza: The Electronic Computer Enterprises ZETO located in Poznan is currently offering to those customers who use Ryad series of

computers with DOS operational systems an improved version of the Step-Baza software package. It differs from the original version by improved function that allows updating the record fields at the level of the Sezam system assembly. Based on a generation process identical to that used in the original version, the program of file modification has been enlarged to include a function for updating an arbitrary field and also for signaling eventual overfills. These improvements allow compiling data bases that can be conveniently used for documentation systems.

For information, contact Bogdan Niemczyk, ZETO Poznan, ul. Fredry 8a, 62-967, Poznan, telephone 516-34, telex 0413380.

#### Direct Access to the R-32

The electronic computer technology enterprises ZETO (Wroclaw) offers for users of the R-32 computer, which have monitors Mera 7900, local or remote (compatible with IBM 3270), terminals IBM 2270, 2780, 3780 and specialized terminals such as those used in banks, remote control units, programmed units, etc., a direct access system connecting remote users to a centralized mainframe computer. The system covers the following areas:

- banking calculations
- security
- inventory control
- personnel services
- general information for industrial management
- production planning
- reservations at travel agencies
- sales data files in marketing
- statistical data collection
- collecting data from production lines
- foreign trade computations
- documentation of contracts and current performance control
- bookkeeping.

The system ensures continuous access to special data in the functional areas concerned and allows presentation of results directly at the workplace--from director's desk (general management information) to a teller's window (bookkeeping and finance). ZETO Wroclaw offers also ready-to-use applications software, services in preparing new applications systems and a two-level course for current and future users of service programs in the areas listed above. The system is compatible with the CICS system of IBM.

Address: Zaklad Elektronicznej Techniki Obliczeniowej [Electronic Computer Technology Enterprises]; ul. Ofiar Oswiecimskich 7/14, 50-069 Wroclaw; telephones 44-54-31 through 37; telex 07125333 ZETO PL.

#### Emulator Application for R-32 Computer

Warsaw PRZEGLAD TECHNICZNY in Polish No 5, 29 Jan 84 p 29

[Letter by Krzysztof Perycz, ZETO Gdynia: "Interactive Feedback: Accomplishments and Prospects of Computer Science"]

[Text] For reasons beyond my control, it is only now that I can offer my remarks concerning the article by Marian Kuras, "Accomplishments and Prospects of Computer Science" (PRZEGLAD TECHNICZNY 37/83).

As one of the participants in the development of the Odra-1305 emulator on the R-32 developed at ZETO-Gdansk, which is currently operating at four centers throughout Poland, I think that the section of the article concerning the utilization of Odra programs on the R-32 seems especially questionable.

The problem of transferring programs from one computer to another, as well as developing software that is independent of hardware, is an involved and complex one. Mr. Kuras urges toward the development of instrumental software "for generation of programs in the R-32 code from source programs processed on the Odra." Unfortunately, because of the basic differences of the equipment and the operative systems and the individual implementations of languages of this series, a software system of this kind would basically be a conglomerate of separate algorithms.

Transferring programs in this way would be tantamount to rewriting them in the R-32. Furthermore, although these programs would have an adequate static structure, errors could be generated during their operation. It is a fact that the translation process itself does not take into account the dynamic structure of a program.

One general method that guarantees proper performance of all transferred programs is the method of emulation. One is surprised, therefore, at Mr. Kuras's statement that "Odra emulator on an R-32 [...] is basically an emergency solution and a highly ineffective one."

It is unclear whether "emergency" stands for "to be used in emergency situations" or "having traits fraught with emergency," but, based on experience with our emulators, we cannot agree with either interpretation.

After 18 months of work by a three-person team, it is now possible to translate directly into the R-32 all Odra programs at a speed slightly slower than on the Odra 1305, and the installation cost of an emulator is about 800,000 zlotys, so that the description "highly ineffective" does not seem a fortunate one.

I would appreciate your publishing this letter.

#### Editor's Response

We agree with the author of the letter in part, where he questions the desirability of developing instrumental software "for generation of programs in the R-32 output code from source programs processed on the Odra." When, in another part of his letter, he writes, that one general method that guarantees appropriate implementation of all transferred programs is the method of emulation, he should, however, clarify the issue completely, stating that the emulation method is, in fact, an application in a narrow range of what is proposed by Mr. Kuras. Since the application scale is here relatively narrow, the resulting errors and imperfections are also insignificant, and this makes such a method preferable for use when a software transfer is required.

#### Meritum-1 Home Computer

Warsaw RZECZPOSPOLITA in Polish 10-11 Mar 84 pp 1, 8

[Article by K.Sz.: "First Polish 'Home' Computers; Exclusively on the CEMA-Manufactured Assemblies; Priority Supply to Schools and Educational Institutions; From a Game to an Industry"]

[Text] (from our own correspondent) The Mera-Elzab Computer Enterprises in Zabrze have initiated the manufacture of the so-called "home" or "personal" computer. For several years, they have been popular in the West. It now turns out that in this area we are not all that backward.

The Meritum-1, as the new product is called, was developed in cooperation with the Polonia Enterprises ITM from Krakow and was shown in Poznan at the Fall 83 Fair, where it was received with interest. The first experimental series of 20 units have all been delivered to selected research institutes and some electronic engineers for testing. User reception so far has been positive.

In 1984, the Zabrze Enterprises are preparing--in terms of materials--for turning out 1,000 personal computers. The final number, however, will be determined by conditions of a contract with the Ministry of Education. Mera-Elzab plans to begin equipping high schools with its home computer, especially those of an engineering profile, and also other educational institutions. The emphasis is on training people in using computers and eliminating the public illiteracy in this sphere. For that reason, initially there are no plans to sell home computers to individuals, although there is no shortage of prospective buyers despite its high price--160,000 zlotys.

The Meritum-1 has been made exclusively of domestically produced components or imports from socialist countries, including Soviet-made memory and micro-processor manufactured in the GDR.

The Zabrze Enterprises will not be limited to just one computer type. According to Mera-Elzab director Boleslaw Rzycki, design work is continuing on the next versions: Meritum-2, Meritum-3 and Meritum-4, which will allow using the personal computer not only for teaching the elements of computer engineering in schools or as a sophisticated toy, but as a unit for controlling engineering processes in industry.

9922

CSO: 2602/18

SOLUTIONS TO SCIENCE-TECHNOLOGY-ECONOMY TRIANGLE STRESSED

Uniform System, Policy Required

Warsaw RZECZPOSPOLITA in Polish 7 Mar 84 pp 1, 4

[Article by W.B.: "Scientific and Technology Thought: Difficult Tasks in Difficult Conditions"]

[Text] (from our own correspondent) How can we make use of all possibilities of science as we emerge from the crisis? How, despite the shortages, can we solve difficult problems? Finally, how can we maintain the research potential and build into the management and economic mechanisms authentic and efficiently functioning methods of cooperation between science and practice? Basic questions of this type are intensely explored in scientific communities--including the Polish Academy of Sciences [PAN]. These issues were the subject of discussions at the national meeting between the learned secretary of the Academy, Professor Zdzislaw Kaczmarek and directors of research institutes, the first secretaries of local organizations of the PZPR and coordinators of research projects held on 6 March 1984 and attended by the President of the PAN, Professor Jan Karol Kostrzewski.

Analyzing the research potential (particularly intellectual capacities of individual scientists and research groups), the conference noted general rise in the cost of research--increasing prices of materials, components, equipment, etc. In the meantime, allocations to research have been declining (0.8 percent of the GNP in Poland compared with 4.8 percent in the USSR and 4.0 percent in other socialist nations). This creates a difficult situation and calls for the economy, on the one hand, to present its demands and for science, on the other, hand to offer its specific contributions more aggressively. It is also necessary to introduce elements of so-called economic pressure that would cause the industrial enterprises to introduce new technologies and solutions.

One of the requirements mentioned at the conference was increasing the coordination between international cooperation and the needs of our research projects.

Coordinating development concepts and needs and assignments in the tripartite system of science-technology-economy is essential. There is no uniform

nationwide policy in this area. Technological progress must be brought about both by theoretical scientists and by practitioners--including those working at individual enterprises. On this issue, a shared participation and responsibility was suggested--the PAN should be responsible for basic research, while the Ministry of Education would be concerned with personnel training, and a new government agency would be set up to supervise technological progress. These requirements were supported by the position taken by the Board of the PZPR Party Organization of the PAN, which was represented at the meeting by the First Secretary of the organization, Professor Marian Swietlikowski. The document of the party organization underlined, among other things, a need for government financing of basic research and the recommendation for setting up a superministerial government agency for matters of scientific and technological progress, and acknowledging the PAN as a national central agency of basic research, including planning, financing and reporting these activities to the government; at the same time, a program of applied research and technological development should be compiled for the coming 10- and 15-year periods.

All these basic strategies and specific research assignments have to be undertaken in difficult conditions. The estimated shortage of financing, 1.7 billion zlotys, as related to the signed contracts and undertaken obligations, urges to seek support from other ministries and branches. If the budgets of scientific institutes are not provided additional financial support from outside sources, the threat of limiting the research programs will become a reality. This eventuality would have an adverse effect on the nation's development and would be contrary to the basic proposition voiced in the speech of Professor Saturnin Zawadzki, deputy learned secretary of the PAN: "The most important task facing Polish science and, in particular, the institutes of the PAN is conducting scientific research in areas and fields that would guarantee for the nation a speedy emergence from the crisis and so help advance the economic, social and political progress."

There can be no doubt that, without original Polish scientific and technical thinking, a return of the nation to the league of countries with developed economies and technology, producers of modern and competitive products, is unthinkable.

#### Problems, Solutions Discussed

Warsaw PRZEGLAD TECHNICZY in Polish No 10, 4 Mar 84 pp 17-19

[Article by Witold Ochremiak: "Where Shall We Be Seeking Solutions?"]

[Text] The meeting of representatives of scientific and technological communities with Premier Wojciech Jaruzelski, Vice Premier Zbigniew Szalajda and Ministers Wladyslaw Baka and Stanislaw Ciosek was aimed at airing various opinions and identifying the major issues to be resolved by and for these communities in the nearest future. Evaluations were also made of the views and positions, as well as accomplishments and expectations associated with technologic activities.

Nobody was paying compliments to anybody. The opinions and views were stated without hiding fears and doubts. Speakers were frank and competent and called for current and future solutions. This was the stance adopted at the discussion by representatives of scientific communities and scientific and technical associations, as well as members of the highest government agencies. Would that all meetings had this nature, were as substantial and gave so much nourishment to thought.

In three reports from the conference, we have presented selected problems and opinions on a number of individual issues. In this last report, we present the opinions expressed by representatives of the government (the speech of the premier was reported in PRZEGLAD TECHNICZNY No 3/84), and a number of issues not covered in preceding reports.

Concerning numerous positive results of changes in methods of economic management, several speakers criticized some of the solutions adopted in the system of financing of the economic reform. Minister Wladyslaw Baka objected to this criticism, noting that in the past two years the tendency for degradation has been stopped and the economy has entered the path to revival and productivity growth. The negative tendency for increased material-intensiveness and energy-intensiveness that had been developing for many years has been now reversed. The management of working time has improved, although not as much as would be desirable.

This does not mean that there are no negative phenomena which should be countered. Most important is, therefore, closing ranks around the program of the reform, in which the NOT [Chief Technical Organization] recommendations concerning the operation of the economic mechanisms would be utilized. Minister Baka confirmed, in particular, that the NOT Committee for Scientific and Technologic Policy has been helpful in formulating the views embodied in the reform of the concepts of systemic solutions relating to technological policy and progress. In practical terms, the resolution of the Council of Ministers of 16 Oct 1983 concerning the modification of reforms in the area of scientific and technological progress was based in its entirety on NOT recommendations.

Against the background of the price revolution effected in early 1982, a certain stereotypical opinion has developed, suggesting that prices are established arbitrarily. It is well known that we had to relinquish an artificial system of economy with absurd price structures that represented nothing and were not based on any economic indicators. Price absurdities had been growing for decades. As they were eliminated, these discrepancies and structural disproportions of prices, and disproportions in incomes, gave rise to inadequacies and even pathological phenomena. These difficult problems, however, cannot be solved without any errors in day-to-day practice.

In regard to criticism addressed to price and wage policies, Minister Baka asked NOT representatives for assistance in assigning a proper measure to the category of justified costs, where economic factors are in conflict with technological factors. Costs cannot be evaluated without a normative base.

This base should be provided by technologists and not accountants. Joint work by economists and technicians will be needed to develop an adequate technico-economic infrastructure. The future of the reform is predicated on this joint effort.

There are no intentions to standardize the management patterns in industry. On the contrary, we urge enterprises to create different systems, both by aggregation of industrial units and development of smaller independent and satellite enterprises. The basic point here should be the technicoeconomic characteristics of the individual branch of industry and type of product. The structure and management are different in cement industry, coal mining and such industries as power production than in the manufacturing of beauty aids. One common criterion should be cost-effectiveness. Systems that are created may step beyond the framework of a single ministry. This calls for breaking the traditional habits and bureaucratic barriers. All these efforts affect various aspects and undertakings involved in the implementation of the economic reform.

In response to doubts and fears concerning the creation of different systems of incentives, Minister Stanislaw Ciosek said that for many years the practice of wage incentives was neglected. Remunerations had no direct relation to the results of work. This is an established practice that is difficult to abolish. Major restructuring of the remuneration system has been undertaken under the auspices of the economic reform. There are both instances of wide wage gaps and excessively flat rates. Introducing experimental systems of remuneration linked to more specific output quotas and streamlined personnel policies are expected to change the attitude towards work and satisfy all those who want to and can work well.

Would it be proper to treat the engineers and technicians specially and apply to them different rules, with centralized setting of rates of their wages? Minister Ciosek stated that all employees, including the managerial staff, should obey the same rules, and their salaries should be linked directly to the production output and financial effects of an enterprise. Wherever the work of an engineer is creative and brings concrete results and profits, the engineer will earn more, and where no such accomplishments are achieved, he will earn less. It should be remembered, however, that the process of rebuilding the wage system will take several years.

The speech by Minister Ciosek generally was a rebuff to opinions presented by some of the speakers expressing the views of some members of the scientific and engineering community. This concerns, in particular, the view expressed by Dr. Eugeniusz Budny that "in the current economic situation and the system of reform, there should exist interrelations between the facts of technological progress and remuneration." This has not yet been achieved, especially in scientific and research institutes, whose products are of a special kind and are measured differently from industrial productivity.

Special attention should be paid, against this background, to the acute needs of the economy and the changes that have taken place in the requirements

laid before the scientific and research institutes. This was mentioned by Professor Henryk Baluch, Director of the Central Institute of Research and Technological Development of Railroads: "Many groups of workers at scientific research institutes should currently be directed to concentrate on solution of urgent problems. Not everybody likes that. There are some who believe that such work is not scientific and should not be counted among results obtained. We must object to that. It is this kind of work that quite often generates cognitive discoveries that call for further profound theoretic investigations. Such work has yielded real results which helped verify the proposed solutions. This approach also teaches one to be responsible for errors. It brings, overall, more satisfaction than some pseudotheoretic studies which are still done in Poland by too many engineers." This view is worthy of note.

An important stimulus was given to discussions by the issues of creation and development and technologic policies on a national scale. The speakers were unanimous in supporting the proposals to establish a State Committee for Scientific and Technological Progress, and many also spoke of the broader aspects of coordination and international cooperation in ensuring progress in science and technology. It is impossible to focus on all aspects of research and development in all fields of technology at the same time, while, on the other hand, most areas call for substantial improvement. Faced with this dilemma, we should acknowledge that an important addition to our own research should be large-scale international cooperation. Numerous links with Western nations have been broken through no fault of Poland's. Under these conditions and circumstances, particular importance is attached to cooperation with research centers of socialist nations. This was mentioned in particular by Professor Jan Rychlewski, who said, "Today we cannot speak of developing strategic trends of scientific and technological progress in our country without seeing them in the context of all socialist states."

The mechanisms of integrated action in the framework of the CEMA are being constantly improved. Professor Rychlewski, however, pointed out that the agencies of this cooperation do not enjoy sufficient prestige among scientists and engineers in Poland, and not only in Poland. This situation can and should be changed. Professor Baluch stressed this need also. We must work to ensure that cooperation is not limited--as often is the case--to development of common standards and recommendations. We are not using to the fullest extent the capabilities of introducing new major innovative actions in the framework of CEMA coordination centers. Neither the degree of specialization nor the specific nature of projects are satisfactory.

In connection with the speech by Jan Czapka, a private farmer and innovator who has designed several interesting farm machine projects, the matters of inventions and discoveries were debated. He voiced the opinion that: "Inventors and innovators are different from the rest of the community, and they should be given support the way we care for new breeds of plants. With good care, one can always obtain better crop harvests and better profits."

The Sejm member, Dr. Lidia Jackiewicz-Kozanecka, who is an independent scientific research worker and inventor, mentioned the opinion expressed by the Sejm Commission for Scientific and Technological Progress and pointed out the huge reserves that are hidden in the possibilities of inventive and innovative activities but are still not utilized to an adequate degree. There are too many barriers to implementation of creative technical ideas and embodiment of new concepts in technologies and products. Bringing down these barriers and obstacles should be done by legislation, and specifically updating of the law on inventions. Scientific and technical communities are waiting for this, as are all inventors and innovators and the entire economy.

In this discussion, a different aspect was also raised. Professor Jerzy Szyrmer, Chairman of the Society of Agricultural Engineers and Technicians, said: "It is good that farmers want to and can design machines and tractors. But the view that this is a normal situation and that it would be good for farmers to create more of these machines is generally a misunderstanding. It is the task of industry, after all, to produce these farm implements. This is the situation all over the world. Every innovative initiative should meet with our favorable reception and support, but we still expect industry to produce the means of production. If these are not sufficient, there will not be enough food in the country. We must say it outright: if we want to have enough food products, we must change our mentality, develop the industry and services to support the producers of food."

Another important issue was raised--the considerable drop in freshmen enrollment in technological specialties. Professor Jerzy Doerffer addressed his appeal to the premier for personal intervention to counteract this trend. The regression in the economy that we are experiencing will end sooner or later, and then we will need well-educated and sufficiently numerous cadres of engineers. Educational planners lack imagination, so they should be reminded that those entering school this and the next year will graduate at the end of the century and will become good and independent engineers only after the year 2000. We must think of this and even today prepare the cadre for the future. Intensive technological progress calls for the development and modernization of the material facilities in our schools, to enable them to train the engineers for an industrial environment that will exist in the early years of the 21st century.

Vice Premier Zbigniew Szalajda concentrated his comments on technicoeconomic problems facing the nation and the professional and social attitudes of engineers. He said that, as an engineer, he feels confident, and his job calls upon him to evaluate the government activities as regards technological progress and society.

The government has the duty--said the vice premier--to preside over the development of new technologies in all areas of the economy and at individual enterprises, to subsidize the scientific and technological base, to support the work of scientific and technical institutes, to provide adequate education and lines of study and guidance to centrally financed research projects, which are the major milestones in the the nation's progress;

finally, it is responsible, through implementation of joint projects, for ensuring an adequate division of specializations and functions in the framework of international cooperation. All these aspects make up the government's technological policy.

With this concept of technological policy, many new technologies and methods, licenses and investments have been introduced, the scientific and technological bases, institutes of the PAN, other research and development centers and enterprise laboratories are being developed. The research and development areas have been defined in government programs and nodal problem areas. Spending on science and technology in 1984 will exceed 80 billion zlotys and be 19 percent higher than the figures for 1983. This may not be too much, but creates the possibility for continued research, experimentation, introduction of new products and application of innovative solutions.

Realizing these plans is not easy or simple--and not just because of a lack of finances or material base, although in this area limitations are substantial. For instance, although we have a government program of coal processing, many years of discussions among scientists, engineers and technicians still have not produced an acceptable concept of what should be done in this area. Each government decision has found its champions and opponents. Fifty percent are for and 50 percent against. This is not an isolated example.

Controversies appear as technical policies are implemented, and instead of consolidation of forces, we observe their scattering. Why is it so that, after a field of research on an important problem is defined, years of debate and scrutiny of various alternative solutions by a narrow circle of specialists still fail to produce a consensus? One can say that it is not always necessary or desirable that all views be in agreement. This is certainly true, but after hearing and discussing various views and proposals, we have to reach a decision, choose a way and make some progress.

Opinions often vary as to the localization of individual industrial enterprises (for instance, metal or cement works). All want industry to develop, but most agree to have in their areas such industries as tourism or beauty aid manufacturing, that is, industries which are not hazardous for the environment. Often more attention is given to this consideration than to the possible ways of protecting the environment while developing industry.

Speakers mentioned that there are no material or personnel obstacles to the development of microprocessors. Why is it, then, that we are so far behind in their per capita output? Why in the output of synthetic materials do we occupy last place among the CEMA member nations? Why are we not making any real progress in automation and application of robots and the robot manufacturing plants have no contracts with domestic industry and are eagerly looking for new markets? This does not concern any sophisticated processes but ordinary automation in transport, difficult and heavy work, and other functions that we can easily tackle as engineers.

Vice Premier Szalajda mentioned only one issue in construction industry. This problem does not concern investment or hard currency but is nonetheless important. The issue is the waste of enormous amounts of heat because of poor building insulation. If nothing is done, this will cause a waste of millions of tons of conventional fuel before 1990. And yet this is a problem of utilization of existing materials requiring no new technologies.

Container manufacturers do not have markets and have to switch to different products, while in our merchant fleet the indicator of the use of containers is one-fifth of that in other nations. A similar situation is observed in freight transport. We are used to waiting for actions and decisions coming from the center or government. This is important in general questions, but even more important is to break the certain frustrated attitude that has set in among engineers in recent times.

The inventive and innovative activities dropped by almost 60 percent in 1982 compared with 1979. Why did this happen? After all, innovation is the function of engineers, and they decide on matters of technological progress and innovation. We are updating the respective legislation, and regulations on innovative projects have been completed. This will be a sound basis for promoting inventiveness. One question, however, needs clarification. What are the professional responsibilities of an engineer? Is it true that whatever an engineer or technician does should be treated separately and exclusively as an innovative solution or an invention? Every engineer must select the most modern and most cost-effective materials for designs and introduce the best existing technologies. This is his job. The list of materials that we are importing currently has more than 700 entries. Maybe some engineers have not yet received it and it should be made available to them. Of course, substitutes should be used, which does not mean that this will be temporary or poorer-quality materials. These must simply be our domestic solutions and good solutions at that.

Somebody has come with the theory that in 1981 and 1982 quality must have deteriorated, because we began to use substitute materials. This is a major problem. Nothing has changed in supplies, but in 1983 quality was worse than in 1982. We must see here an important factor--the poor level of organization of the production process, lack of responsibility for quality on the part of enterprises, inefficient internal interoperational control, which is delegated to consumers. These objective factors still play an inadmissibly large role.

Our typical failure is to notice our neighbors' mistakes and not ours. The shipbuilders are complaining that they receive poor materials and equipment and that for that reason the boats they are building are of a poor quality. But building ships can also be sloppily done. In one shipyard they simply did poor welding jobs. We all must care for our own jobs, so that we do not make life difficult for others and supply them with "lemons."

Eighty-five percent of management personnel in Poland are engineers, but we hear that there is no work at factories for designers. Why is it so that an engineer director doesn't find a designer or process engineer of help? Who should we ask this question of? Where can we find a solution? Yet, we should not draw pessimistic conclusions. Most administrative and technical directors and supervisors, despite the current employment pressures, are thinking about development and future prospects for their factories.

Scientific and technical assignments have been discussed and stated in detail for 1984, and 100 government contracts have been signed in this area. Standards for implementation of new developments and conventions have also been set. This year is the first one with this thoroughly organized statement of assignments, and real safeguards for their implementation. This must yield good effects.

Vice Premier Szalajda suggested holding the next conference at the end of the first quarter for a reciprocal exchange of information on the results achieved in implementing the suggestions and proposals put forward in December 1983. This will be an important criterion testing the value and effectiveness of such meetings.

9922

CSO: 2602/17

## DEVELOPMENT, CONTROL OF SCIENCE ASSESSED

## Basic Research Stressed

Warsaw RZECZPOSPOLITA in Polish 21 Mar 84 p 6

[Article by Witold Blachowicz: "Basic Research: Untapped Skills and Capacities"]

[Text] Physics--one of the basic sciences concerned with the study of the structure and dynamics of matter in the broad sense--enjoys an aura of mystery which it owes to the discoveries of natural laws and correlations that it has made. The requirement of abstract thinking, the capacity for correlating cognitive phenomena and their reciprocal effects, the skills of penetration into totally new areas and regularities--all this makes physicists the aristocrats of science. Many of them indeed have this perception of themselves--the element of original creativity is often emphasized here--resembling architects, who often speak of themselves as the elite in the engineering profession.

Regardless of the merits of such ambitions, it is a fact that physics is the basement for development of many natural sciences and fields of technology. Results attained by developing the newly created fields of physics--such as in physics of semiconductors, dielectrics and magnetic materials, the physics of metals, studies of the atomic nucleus, plasma and neutrons, in optics and spectroscopy, in atomic and molecular physics and, finally, in the physics of extreme states (high pressures, vacuum, high and low temperatures) have enabled progress in many areas of chemistry, biology, astronomy and modern engineering. The latter is illustrated by research results obtained by the physics of nuclear particles and the implications these have for the development of electronic computers and information technology.

Physics covers a broad scope, and each new trend poses new problems and offers new prospects for discovery. These capacities are large despite the views voiced by specialists in other areas--for instance, biologists saying that physicists are incapable of explaining natural phenomena such as those taking place in the living cell and, especially, complex organisms. They

claim that methods and approaches practiced by physicists "in many respects are already inadequate." There must be some truth to these reservations, but no one knows for sure whether these limitations should be blamed on the basic essence of physics or on mechanical transplantation of physical techniques into other fields of research.

### Strength in Theory

An exhaustive evaluation of the current state of physics--research conducted in Poland as compared to world trends and the requirements of studies in new directions--was made at the Second Congress of Polish Science. Most suggestions offered at that meeting are still relevant despite unfavorable changes of conditions for implementation of some of these recommendations. In particular, a number of issues are discussed in the latest report of the PAN [Polish Academy of Sciences] and the Ministry of Science, Education and Technology: "State of Basic Research in Poland and Its Influence on Development of Applied Research," submitted to the Sejm Commission on Science and Technological Progress.

With a certain simplification, it can be said that physical research in Poland is concentrated on solid state physics, elementary particles and atomic nuclear physics and studies of the effects of electromagnetic radiation on matter. There is a view--shared in other countries--that in these areas Polish physicists have obtained many results of worldwide importance. For instance, in solid state physics--where the research results have direct implications for electronic technology and its progress--the Warsaw School of Semiconductor Physics enjoys world renown. Warsaw physicists have earned this reputation thanks to a pioneering contribution to deciphering the elementary electronic processes in semiconductors. A basic discovery in the physics of elementary particles was also made in Poland: a new type of atomic nucleus--the so-called hypernucleus--was discovered, opening a new trend for research into the structure of matter. Our physicists have scored major successes in studies of strong interactions causing "production" of many elementary particles, even though, unfortunately, they do not have expensive equipment necessary for this kind of research--such as accelerators. New solutions of Einstein's equations have also been found in Poland, which describe the properties of so-called gravitational waves. International recognition has been also won by Polish studies in the physics of dielectrics, particularly nonlinear dielectric phenomena, the so-called dielectric saturation; other examples could easily be given.

Their importance was emphasized, in particular, by the Second Congress of Polish Science, where it was said, for instance, that "... because of the high status and level of theoretical physics in our country, it is desirable for this fact to be given an adequate reflection in PAN activities, which should set up a special institute to be concerned with fundamental and basic research." This requirement, as many other ones, could not be implemented, because, shortly after the Congress, the lean years set in.

## Below the Needs

The fact that we have valuable results in theoretic physics does not mean that there are no comparable achievements in applications and practical technological uses. Many of the physical research results have been applied in electrical engineering, material diagnostics and measurement and control instrumentation in modern equipment, designs, nuclear technology, production of new materials for the electronics industry, such as the technology of semimagnetic semiconductors. By the joint efforts of Poznan physicists (the Institute of Molecular Physics of the PAN at Poznan) and specialists from Tonsil Enterprises in Wrzesnia, many problems in production of electrolytes and their applications in state of the art electronics have been resolved.

Every year some of the achievements of physical science help advance various branches of studies and new trends in technology. Yet, this movement of results and the scope of effects achieved do not seem to correspond either to our needs or to our potential. It is too often that revealing concepts and theories simply remain in the minds of their authors or eventually are published in narrowly specialized journals. Shortages in research equipment, inadequate supplies for laboratories and other such obstacles too often destroy chances for practical application.

Since there are no realistic hopes that this situation will improve soon, we must seek the possible compromise solutions. First of all, the existing equipment should be used more efficiently, and the forms of cooperation between research institutes should be improved. Great results could be certainly obtained if eminent physicists were given access to facilities available in industry which often are more modern than what is available in research laboratories.

It seems that industrial enterprises which today are more independent could benefit from such an arrangement. The question is: will managers muster vision to link the potential of physicists with the benefits for the field of industry or the particular organization? Certainly, without such contacts, we cannot speak realistically and in the long term about emerging from the crisis, creating new generations of materials and products and developing new markets.

## Research-Development Trends Outlined

Warsaw TRYBUNA LUDU in Polish 2 Apr 84 p 4

[Article by Tomasz Miecik: "Forty Years of the Polish People's Republic: Science for the Nation"]

[Excerpt]

### Continuity of Traditions

In the "Report on the State of Polish Science," prepared at the beginning of the 1980's, it was stated that Polish science is at an average level

compared to other European countries. The post-war period in the history of Polish science witnessed the preservation of continuity of Polish scientific traditions, as illustrated by continuing existence of important scientific schools and most established trends and also development of new and strong scientific schools in the Polish People's Republic.

Contributions by Polish school of mathematics belong to the most important scientific results achieved in People's Poland. The list of famous mathematicians includes Waclaw Sierpinski, Kazimierz Kuratowski, Karol Borsuk, Stanislaw Mazur, Wladyslaw Orlicz, Hugo Steinhaus, Kazimierz Urbanik, Tadeusz Wazewski, Roman Sikorski, Stanislaw Lojosiewicz and Jan Mikusinski.

No less valued are results in physics, where such names as Marian Danysz, Jerzy Pniewski, Andrzej Trautman and Leonard Sosnowski should be mentioned.

Important results have been achieved by Polish scientists in theoretical and applied mechanics, especially in groups directed by Professors Witold Nowacki, Waclaw Olszak, Sylwestr Kaliski and Jerzy Litwiniszyn.

Original results have been obtained in chemistry, especially by groups of Professors Boguslawa Jezowska-Trzebiatowska, Wlodzimierz Trzebiatowski, Wlodzimierz Kolas and Wojciech Swietoslawki. In particular, an innovative method for production of silicon oxide has been developed by Jerzy Grzymek and Stanislaw Bretsznajder.

Major advances have been made in studying Poland's geologic structures, which resulted in discoveries of central deposits of copper and sulfur, zinc, tin, coal and potassium salt.

Pioneering studies have been done in natural conservation and protection of natural resources, mainly the work directed by Professors Wladyslaw Szafer and Walery Goetel.

Neurophysiological findings of Professor Jerzy Konorski and his group belong to important results of Polish science. Among other medical studies, mention should be made on the work on new methods of surgical treatment--cardiosurgery by Professor Tadeusz Krwawicz and surgical treatment of deafness by Professor Jan Miodonski, operational treatment of vertebral diseases by Professor Adam Gruca and health, professional and social rehabilitation by Professor Wiktor Dega.

In agricultural science, especially in the growing of new crops, important results have been achieved by groups headed by Tadeusz Wolski, Andrzej Slabonski, Kazimierz Roguski and Felicjan Dembinski.

A place of distinction is held by results in studies of social evolution, such as the study of the origins of the Polish state and archaeological discoveries (Henryk Lowmianski, Witold Hensel, Kazimierz Michalowski and their colleagues) and research into proper economic development during the time of socialist construction conducted by Professor Oskar Lange.

## Involved Picture

One could broaden this list or disagree with its composition.

This, however, will not change the fact that the picture of Polish science is extremely uneven, that it has made major contributions of world renown and yet cannot meet expectations of the economy and society.

There can be no argument, however, that science does not operate for its own benefit, that its results should serve the development of mankind's societies and nations. Whatever selection we make for a list of definite accomplishments of Polish science, we will find that in natural sciences important results are observed primarily in theoretic studies; that in technical sciences, successes mostly concern basic studies rather than practical applications of latest technological ideas; that in social sciences, development is fairly sporadic, with a negative selection and lack of interest in areas that constitute the main concern of government and the public (such as economics).

For that reason, the resolution of the Ninth Congress of the PZPR noted that "science and technological progress are unused reserves of our nation, and utilization of available scientific studies and their further advance are a major way out of the crisis, which, among other things, itself is indication that science has fallen behind the nation's demands."

After disarray caused by the changing forms of economic management in the country and the crisis conditions in which, however, science--in keeping with the resolution of the Ninth Congress--is, as far as possible, protected from the current difficulties, it seems a change is about to happen in the understanding of the links between scientific and technological research and the needs of the nation. At least four tendencies are beginning to be seen which reflect the directions of scientific research and development activities.

◆ The first is the contribution by science and technology to meeting the essential social and economic needs; an illustration of this change of orientation is the group of centrally guided research programs which place priority on projects of most likely rapid application, the highest possible cost-effectiveness in technological efficiency regarding urgent issues such as food production, the economy of savings based on domestic technologies, materials, assemblies, etc.

◆ The second trend is the need for a strategic guidance of research and development for the coming 10 to 15 years, capable of providing infrastructure for rebuilding of the economy and society. This is determined by the current and future situation in the country, the possibility of ranking the development problems differently from the current set of priorities. An example of activities in this area is the current work on a long-term plan of scientific and technological development until 1995 and even to the year 2000.

♦ The third area is ensuring progressive development of scientific research, particularly basic research, that would provide inspiration for the futuristic technology and industry.

A plan of such research is being drafted by the Polish Academy of Sciences, and it is based on the principle that, in addition to incorporation of the trends of world science, it should, to a greater degree, be tailored to the current and future needs of Poland's national economy. The Academy is beginning to realize that the extremely difficult economic situation and restraints on international exchange, on the one hand, and the large research potential available to the PAN institutes, on the other, now enable and urge Academy to undertake, in addition to basic research, work on pragmatic problems crucial for the national development.

♦ The fourth trend is reorientation of programs of scientific and technical cooperation with other nations, particularly in the CEMA framework, and bilateral cooperation with socialist countries, aiming at a fuller coordination of research and development projects and joint studies. At the same time, this means subordinating the cooperative programs to solving major national issues and avoiding secondary projects that bring no concrete results.

No doubt, all these tendencies will become crystallized before the Third Congress of Polish Science. Scientists believe that before this Congress and during its course the possibilities of government in supporting scientific research will be delineated, that major principles of scientific and technological policies will be formulated. Society--with all the awareness that science, and especially science in a medium-sized nation, cannot offer a panacea to all troubles and difficulties in society and the economy--expects, however, that the scientific community will provide tangible evidence of their involvement in national problems and will give proof of usefulness of scientific research. This will be essential for the climate in which science functions as well as for its own sake.

#### Scientific Organization, Control Criticized

Warsaw ZYCIE GOSPODARCZE in Polish No 15, 8 Apr 84 p 6

[Article by Professor Stanislaw Lojewski, Member of Research Staff, Chief School of Farm Management-Agricultural Economics, Warsaw, in a series entitled "Let Us Discuss: How Do We Manage Science?": "A Critical View of Organization"]

[Text] (from the editors) In 1984, ZYCIE GOSPODARCZE No 18 published an editorial article entitled "How Do We Manage Science?" and also--as part of this discussion series--an interview with Jerzy Ruszkiewicz, "A Specific and ... Controversial Proposal" (ZYCIE GOSPODARCZE No 25, 1983). Today, we present the views of Professor Stanislaw Lojewski from the Chief School of Farm Management-Agricul-

tural Economics Academy in Warsaw, who proposes a concept of functional management of science at the central level. This article is published as a subject for debate. The views it contains are based, among other things, on studies conducted by special commissions of the Province Committee of the PZPR in Warsaw.

The unfavorable situation in Polish science has been criticized for many years. It results, in particular, from the fact that, both among scientists and the so-called general public, there is the awareness that the intellectual potential of the nation is not being used and is simply being wasted. Criticism of the current situation with science was contained in resolutions of the Ninth Extraordinary Congress of the PZPR, where the need for breaking the barrier between the three levels of science--the Polish Academy of Sciences, higher schools and ministerial institutions--was emphasized.

In the sphere of science as a whole, there is no consistent centralized policy or strategy. This brings about disintegration and further partitioning of science and the scientific community on four levels--legal, organizational, technological and financial. This disintegration is exacerbated by the current charters of individual and artificially isolated levels of science (higher schools, ministerial institutes and research centers of the PAN). This process must be stopped. Science is and must be unified, and a legislative action concerning science should be prepared that would update the legal documents so as to integrate it. This regards, for instance, the law of scientific titles and degrees, which should be updated. A draft of such law prepared by the Minister of Science, Higher Education and Technology in the meantime is introducing a "double squeeze" on science and promotion of younger generation of scientists by proposing an excessively complicated system of multilevel scientific and functional promotions, an excessive number of scientific ranks and titles and "perpetualization" of such titles.

Much time and effort must be spent now to establish and select the directions of the development of science and technology and areas of international cooperation. In the 1970's, in many areas, there were tendencies to make our scientific, technological and industrial progress a function of the highly developed capitalist nations. Our adversaries took advantage of this fact during the economic war forced upon us after 1981.

An excessive dependency of financing of research on independent enterprises may cause regression in technological advancement, and currently leads to depreciation of facilities and the resulting damage to scientific progress and further disintegration of the organizational structures of science.

I would like to speak critically of the existing formulas for scientific organization. These concepts take too little heed of the negative experiences with the current system and the functioning of the former Committee of Science and Technology and several government programs.

The existing system of organization and management of science perpetuate structures that emphasized the isolation and disintegration of research potential and limited the flow of personnel, which is essential for development of science and education, creating insulated closed groups and systems. We now have three spheres of science divided by inflexible barriers: higher education (which embraces more than 60 percent of personnel), ministerial institutes (about 30 percent) and the research centers of the PAN (less than 10 percent).

Organizational concepts discussed now could lead to further disintegration and isolation of these three spheres. They promote organizational divisions (more exactly, bureaucratic organizational divisions) at the central level. This resulted from the fact that these concepts were created to resolve the conflicts of interest between these three groups and are a compromise which is contrary to the principle that science is one.

I have no objections to the idea of creating a State Committee of Scientific and Technological Progress (maybe a better name would be the Committee for Technological Development?), but the name means less than the terms of reference of this committee, because central coordination of the generation of technological ideas and solutions is less important than central coordination of the products of technology--the manufacturing of the means of production--that is, the process of introduction of these concepts and solutions into industry in a broad sense. The committee would be responsible for the coordination of technological progress and the investments involved--would coordinate development or at least forecast the program and plans for this development. The cost-effectiveness of a technological application is important on a microeconomic scale, but macroeconomically, more important is the effectiveness of technological production, which is closely linked (in terms of quantity) with the scale of this production, and the interrelationships between supply and demand, or, more strictly--in the conditions of our social structure--the creation of this demand.

Methodologically, the proposal of dividing the coordination of basic and applied research at the central level is not justified. Nor is the proposal of delegating the functions of central coordinator of basic research to the Polish Academy of Science in its current form.

The Polish Academy of Sciences currently is discharging three functions: a corporate function (General Assembly, sections, committees), the function of a scientific research center and the function of a government agency (the PAN Secretariat).

The scientific research centers of the PAN employ almost 10 percent of all scientists in its 84 institutes and laboratories (data for 1982); half of these are concentrated in Warsaw Province. These organizations are fragmentary, and many of them were created to accommodate certain individuals. The PAN institutes are engaged not only in basic research but also in applications; they operate also as enterprises involved in implementation and dissemination of technology. PAN institutes and centers should therefore

be treated as all other institutes--ministerial and academic institutes and centers--rather than claim special status in receiving funds for basic research.

A condition for proper functioning of a coordination center at the PAN as a corporation of independent scientists from all spheres (education, ministerial institutes and the scientific research centers of the PAN) is therefore steps towards separating from the structure of the Academy its scientific research facilities. If the PAN continues to fulfill its three functions and at the same time the staff of the scientific research centers take over the coordination, this could give rise to preferential treatment, especially as regards central coordination of basic research.

The national interest calls for development of an efficient and integrated system of management of science that would have clearly defined objectives and functions. The development of this system could begin with an analysis of the existing situation and a broader discussion. Decisions cannot be based on the views of a select group of experts representing narrow interests. A science management system should be analyzed by a broad group of scientists from various fields and spheres.

I would like to submit for discussion a concept of centralized functional system of science management that would be based on four principles:

1. The system must take into consideration the reciprocal dependencies of the three functions of science: research, application and education.
2. The interests of the separate spheres of science should be coordinated and subordinated to the interests of a higher rank.
3. The organizational barriers at the central level could be harmful to the public interest. Such division should be made at the ground-floor level.
4. On a central scale, the proper line of development is a functional division that would ensure the balance and recognition of equal importance of the three functions of science and enable their central coordination and management.

The direction of structural reforms in science should be different at the ground level than at the central level.

First of all, efforts should be directed at organization and effectiveness of individual basic research institutions regardless of their affiliation. Their size should be optimized in terms of the number of scientists, the objectives, the possibility of complete performance of research--introduction cycle and specialization, the possibility of creation of technologies and measurement and research equipment, internal organizational structures and the general costs of management and services involved.

I would like to speak only to the specialization and internal organizational structures of the basic research institutions.

A major problem is a uniform policy and program of activity for the short and long terms, such as through a national plan of scientific and technological progress closely linked with financial allocations. We must bear in mind that Poland's overall scientific research potential is too small to allow subdivisions and duplication. Concentration of personnel and facilities and specialization of individual centers (not only at the ground level but also regionally) is necessary for minimizing the scale, which is indispensable for development of the existing trends of scientific and technological progress and specialties. Selecting these trends and taking into account their possible dimensions and the needs of the country is mandatory.

Studies in various fields of science of science (organization, economics, sociology and psychology of science and methodology of research), including research in the Soviet Union and in Poland, suggest that the optimum efficiency is attained by a scientific group within 5 to 7 years. After this period, the proper development will result in specialization and restructuring of the unit. Even in terms of the individual development, 5 to 7 years of work in a certain group and problem area is a maximum time frame for full development of creativity. This should be used as a criterion for restructuring of groups and the movement of personnel to different institutions.

In terms of organizational efficiency and effectiveness of the research process at the ground-floor level, each of the three spheres of science currently has organizational deficiencies that limit the total utilization of available research potential, especially personnel resources. Thus, the dual organizational structures have been a failure, particularly in ministerial institutes and also in other spheres of science.

On the one hand, there is a structure that by way of convention can be called specialized bureaucratic, which includes sections, organizations, laboratories, etc., and on the other hand, the subject-problem structure, that is, research programs (including government-supported programs and problems) which are subdivided into subproblems, trends, group subjects, individual projects, etc.

Both the former and the latter types of structure in this bureaucratic machinery employ too many managers, who mostly are scientists (professors and associate professors) or prominent experts and who, instead of creative work, have to waste time on paperwork, organizational and personnel activities. Generally, many of such managers are incapable of performing these functions. Due to this duality of organization, government research projects, instead of integration that was their goal, actually promote disintegration of research potential of ministerial and academic institutes. Some of the government programs (including a certain government project that I am familiar with) involved attempts by narrow groups of specialists in individual areas and spheres of science to intercept available funds.

In scientific centers in other countries, including the United States and the Soviet Union, the most usual principle of organization is problem-based. Research and pragmatic goals are formulated, and interdisciplinary groups and research centers are created around these problems as temporary (until the problem is solved) organizational structures. I believe that this is the unique way to pull many of our ministerial, academic and PAN-run research institutions from the impasse and stagnation. This uniform problem-centered organizational structure will free human resources from excessive administration of science and focus them on research work. Scientific institutes and centers can be subordinated organizationally, as they are now, according to their specialization, to ministries, industries and production and service enterprises, or sociopolitical organizations. There could also be independent research institutes that would operate in the framework of the economic reform in a decentralized self-sufficient system.

At the central level, however, the divisions should be functional and not organizational. Those three functions mentioned before (research, application and education) can be managed separately at the central level despite their close interconnection and the ground level at institutes and centers regardless of the spheres (academia, ministerial institutes and research centers of the PAN). It is possible, thus, to create three equivalent national centers of functional supervision of research and education of scientists and other professionals.

As regards the national management of research (and, especially, indicating the areas and problems of priority research), such as by the PAN, given the reservations mentioned earlier, it is necessary to ensure close links between basic and applied research, although at the ground level, certainly, there will be specialization in individual phases of this process, including basic research.

In the case of a national management of applications of science by the State Committee for Technological Development, its activities would not only cover research centers but also manufacturing and service enterprises.

The process of education of specialists and scientists should be coordinated at the national level by a special center such as the Ministry of Higher Education and should embrace all spheres of science.

A functional management of science at the central level increases in the conditions of the economic reform the importance of participation by official material-supply and political agencies. This fact has been overlooked until now. A function of management of science at the central level can be conducted by agencies responsible for supply of facilities, primarily financial funds, personnel and equipment.

The concept of a functional management of science at the central level proposed here is certainly not worse than what exists today, but rather, I am convinced, is less damaging to science and the economy. When evaluating an involved and complicated socioeconomic system (and science on a

national scale is an example of such a system), the principle of the lesser of two evils is certainly recommended -- what in medicine is known as "primum non nocere."

Simultaneous implementation of this integrated concept of science management at the central and ground levels will make it possible to conduct a realistic national policy in the three areas, will improve the utilization of available intellectual and material potential and step up the research, development and application processes.

9922  
CSO: 2602/16

END