

ite technical note techn

Target Data Extractor (TDX-2000D) Test Plan

Raymond K. McDonald
William P. Conklin

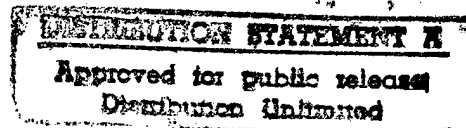

December 1997

DOT/FAA/CT-TN97/23

Document is on file at the William J. Hughes Technical Center
Library, Atlantic City International Airport, NJ 08405



U.S. Department of Transportation
Federal Aviation Administration

William J. Hughes Technical Center
Atlantic City International Airport, NJ 08405

19980417 149

DTIC QUALITY INSPECTED 3

NOTICE

This document is disseminated under the sponsorship of the U.S. Department of Transportation in the interest of information exchange. The United States Government assumes no liability for the contents or use thereof.

The United States Government does not endorse products or manufacturers. Trade or manufacturers' names appear herein solely because they are considered essential to the objective of this report.

1. Report No. DOT/FAA/CT-TN97/23		2. Government Accession No.		3. Recipient's Catalog No.	
4. Title and Subtitle TARGET DATA EXTRACTOR (TDX-2000D) TEST PLAN				5. Report Date December 1997	
				6. Performing Organization Code	
7. Author(s) Raymond K. McDonald, William P. Conklin				8. Performing Organization Report No. DOT/FAA/CT-TN97/23	
9. Performing Organization Name and Address U.S. Department of Transportation Federal Aviation Administration William J. Hughes Technical Center Atlantic City International Airport, NJ 08405				10. Work Unit No (TRAIS)	
				11. Contract or Grant No.	
12. Sponsoring Agency Name and Address U.S. Department of Transportation Federal Aviation Administration William J. Hughes Technical Center Atlantic City International Airport, NJ 08405				13. Type of Report and Period Covered Technical Note	
				14. Sponsoring Agency Code	
15. Supplementary Notes					
16. Abstract The Sensis Target Data Extractor Model 2000d (TDX-2000d) is a Commercial-Off-The-Shelf (COTS) radar signal and data processing system. It is designed to interface with analog radar and beacon systems to produce digital target reports and digital weather vector reports. The system consists of one Signal Distribution Unit (SDU), two redundant Target Data Extractor (TDX) units, a local and remote Control and Maintenance Console (CMC), and an Uninterruptable Power Supply (UPS). This document defines the overall planning, test activities, and coordination associated with the Test and Evaluation (T&E) of the TDX-2000d and Automated Radar Terminal System (ARTS) Interface Unit (AIU) for the Airport Surveillance Radar Model 8 (ASR-8) and its co-located beacon system. The T&E will determine system performance and verify integration with the Standard Terminal Automation Replacement System (STARS) and the ARTS IIA. Test results will aid in the development of National Certification procedures for the TDX-2000d and AIU. The tests will be performed at the Federal Aviation Administration (FAA) William J. Hughes Technical Center, Dobbins Air Force Base (AFB), and at the Atlanta Terminal Radar Approach Control (TRACON) facility. The T&E will consist of Integration tests and limited Operational tests. Technical Center Integration tests will verify that the TDX-2000d and AIU can correctly communicate with external National Airspace System (NAS) equipment (i.e., STARS, ARTS IIA) and evaluate the NAS end-to-end performance. Operational tests will evaluate the effectiveness and suitability of the TDX-2000d and AIU when integrated into NAS. This evaluation will be performed from an engineering perspective. Operational tests will also address: Reliability, Maintainability and Availability (RMA), site adaptation and optimization, and human factors.					
17. Key Words ASR-8, TDX-2000d, AIU, ARTS IIA, STARS, Commercial-Off-The-Shelf, Integration, Operational, Certification.			18. Distribution Statement Document is on file at the Technical Center Library, Atlantic City International Airport, NJ 08405		
19. Security Classif. (of this report) Unclassified		20. Security Classif. (of this page) Unclassified		21. No of pages 56	22. Price

TABLE OF CONTENTS

	Page
EXECUTIVE SUMMARY	v
1. INTRODUCTION	1
1.1 Purpose	1
1.2 Scope	1
1.3 Background	2
2. REFERENCE DOCUMENTS	2
3. SYSTEM DESCRIPTION	3
4. TEST MANAGEMENT	4
4.1 Roles And Responsibilities	4
4.2 Configuration Management	5
4.3 Test Entrance Criteria	5
4.4 Test Completion Criteria	5
4.5 Test Objectives	6
4.6 Test Schedule	6
4.7 Test Locations	6
4.8 Data Recording and Analysis	10
5. DOCUMENTATION	11
5.1 Test Procedures	11
5.2 Quick Look Report	11
5.3 Final Test Report	11
6. TEST AND EVALUATION	12
6.1 System Integration Tests	12
6.2 System Operational Tests	38
7. ACRONYMS AND ABBREVIATIONS	41
APPENDIXES	
A – TEST SCHEDULE	
B – SUMMARY OF RESOURCES	

LIST OF ILLUSTRATIONS

Figure		Page
4.7.1-1	Technical Center Test Configuration	9
4.7.2-1	Dobbins AFB/Atlanta TRACON Test Configuration	10

LIST OF TABLES

Table		Page
4.7-1	Test Location Matrix	7

EXECUTIVE SUMMARY

This document defines the overall planning, test activities, and coordination associated with the Test and Evaluation (T&E) of the Sensis Target Data Extractor Model 2000d (TDX-2000d) and Automated Radar Terminal System (ARTS) Interface Unit (AIU) for the Airport Surveillance Radar Model 8 (ASR-8) and its co-located beacon system. The T&E will determine system performance and verify integration with the Standard Terminal Automation Replacement System (STARS) and the ARTS IIA. Test results will aid in the development of National Certification procedures for the TDX-2000d and AIU. The tests will be performed at the Federal Aviation Administration (FAA) William J. Hughes Technical Center, Dobbins Air Force Base (AFB), and at the Atlanta Terminal Radar Approach Control (TRACON) facility.

The FAA is in the process of replacing older analog surveillance radar systems (ASR-7s and ASR-8s) with the new digital Airport Surveillance Radar Model 11 (ASR-11). The ASR-11 will provide digital surveillance data to STARS. ASR-11s may not be in place at certain sites before STARS is installed. The Interim Digitizer Program was initiated to mitigate the potential risk. The TDX-2000d will accept analog radar and beacon video as inputs and output digital messages capable of supporting the STARS requirement.

The scope of testing includes integration, technical performance, and limited operational evaluations. This test effort is not a National Airspace System (NAS) System Test or NAS Operational Test and Evaluation (OT&E) program. There are no evaluations by air traffic controllers planned. There will be limited participation from Airways Facilities (AF) personnel. The NAS Operational Support Organization (AOS) will provide the TDX-2000d Maintenance and Certification procedures. An approved Requirements Document (RD) will not be provided. A Performance Measures Document approved at the Terminal Surveillance Product Team (PT) level will be used as guidance to determine the T&E success criteria.

The Technical Center Surveillance Branch, ACT-310, will provide the PT, with quantitative T&E results in the form of a T&E Quick-Look Report and T&E Final Report. The T&E results will aid the PT in the determination of the operational effectiveness, suitability, supportability, and maintainability of the TDX-2000d and AIU.

The T&E will consist of Integration tests and limited Operational tests. Technical Center Integration tests will verify that the TDX-2000d and AIU can correctly communicate with external NAS equipment (i.e., STARS, ARTS IIA) and evaluate the NAS end-to-end performance. Tests will be conducted to determine: system coverage, target detection, false alarm rate, range and azimuth resolution, positional accuracy, weather detection and processing, beacon performance, capacity and delay, and system control.

Technical Center Operational tests will evaluate the effectiveness and suitability of the TDX-2000d and AIU when integrated into NAS. This evaluation will be performed from an engineering perspective. Operational tests will also address: Reliability, Maintainability and Availability (RMA), site adaptation and optimization, and human factors.

T&E at Dobbins AFB/Atlanta TRACON is required to completely evaluate the detection performance of the TDX-2000d. The Dobbins AFB location offers an environment with more intensive clutter and weather than the Technical Center. This environment may intensify any problems with extractor detection performance and false alarm rates.

1. INTRODUCTION.

1.1 PURPOSE.

This document defines the overall planning, test activities, and coordination associated with the Test and Evaluation (T&E) of a target extractor for the Airport Surveillance Radar Model 8 (ASR-8) and its co-located beacon system. The T&E will determine system performance and verify integration with the Standard Terminal Automation Replacement System (STARS) and the Automated Radar Terminal System (ARTS) IIA. Test results will aid in the development of National Certification procedures for the TDX-2000d and ARTS Interface Unit (AIU). The tests will be performed at the Federal Aviation Administration (FAA) William J. Hughes Technical Center, Dobbins Air Force Base (AFB), and at the Atlanta Terminal Radar Approach Control (TRACON) facility.

1.2 SCOPE.

This test plan identifies the test activities that will be performed on the Sensis Target Data Extractor Model 2000d (TDX-2000d) system and the Sensis AIU. The plan lists the purpose and objectives of each test activity. The roles and responsibilities of all participating organizations are identified. The plan provides a test description for each identified activity along with the required equipment configuration. It describes the data collection and analysis methods used for each test and provides a summary of resources needed to perform the activities. A test schedule showing the required duration of the tests will also be presented.

The scope of testing includes integration, technical performance, and limited operational evaluations. This test effort is being performed in support of the Interim Digitizer Program and should not be considered a complete National Airspace System (NAS) System Test or NAS Operational Test and Evaluation (OT&E) program. There are no evaluations by air traffic controllers planned. There will be limited participation from Airways Facilities (AF) personnel. The NAS Operational Support Organization (AOS) will provide the TDX-2000d Maintenance and Certification procedures.

A Performance Measures Document approved at the Terminal Surveillance Product Team (PT) level will be used as guidance to determine the T&E success criteria. A Requirements Document (RD) will not be provided. The Performance Measures Document contains the Capabilities Required, Critical Operational Issues (COIs), the Support Concept, Critical System Characteristics (CSCs), and an Infrastructure Support section. Measures of Performance (MOPs) and Measures of Effectiveness (MOEs) are not defined.

The Technical Center Surveillance Branch, ACT-310, will provide the Terminal Surveillance PT, AND-410, with quantitative T&E results in the form of a T&E Quick-Look Report and T&E Final Report. The T&E results will aid the PT in the determination of the operational effectiveness, suitability, supportability, and maintainability of the TDX-2000d and AIU.

1.3 BACKGROUND.

With the procurement and implementation of new digital automation equipment (i.e., STARS), terminal radar systems will be required to provide a digital surveillance output. Several terminal radar systems operating in the NAS provide only analog data. These systems include ASR-8s and their co-located beacon systems.

The decision was made to replace these older radar systems with the new digital Airport Surveillance Radar Model 11 (ASR-11). However, the ASR-11 may not be in place before STARS is installed at the impacted sites. To mitigate the potential risk, methods for providing a digital surveillance output from the ASR-8 to support the STARS interface were investigated. A potential solution was to use the TDX-2000d target extractor. The TDX-2000d will accept analog radar and beacon video inputs and output digital messages to STARS. This would be used until the ASR-11 was integrated into NAS.

Several regions have purchased the TDX-2000d and/or AIU, and are integrating it with their existing automation equipment (e.g., ARTS IIA). The system can provide an alternate method for remoting radar and beacon data. Microwave links and video compression techniques are currently used to provide that function. The potential benefits of using this approach include lower operational costs and improved radar performance. The TDX-2000d and AIU require national certification before they can be used in NAS.

The TDX-2000d must serve as a radar data extractor, beacon data extractor, weather data extractor and formatter. The extractor must perform target detection, range and azimuth centroiding, and resolution of closely spaced aircraft while maintaining a low false report rate. The extractor must also merge radar and beacon reports associated with the same target.

Tests are needed to verify the TDX-2000d and AIU provide adequate performance and can be properly integrated into NAS. These tests will also aid in the determination of the operational effectiveness, suitability, supportability, and maintainability of the system. The test results will provide information needed for development of NAS certification procedures for the TDX-2000d and AIU.

2. REFERENCE DOCUMENTS.

- | | |
|-------------------|--|
| FAA-E-2506 | ASR Transmitter Receiver Subsystem Specification.
Dated: November 12, 1971. |
| FAA ORDER 1810.4b | FAA NAS Test and Evaluation Policy.
Dated: October 22, 1992. |
| FAA ORDER 6310.9B | Maintenance of Airport Surveillance Radar (ASR-7, ASR-7E, ASR-7F, and ASR-8). Dated: June, 18, 1993. |

NAS-SS-1000

NAS System Specification, Vol. I, II, III, and V.
Dated: December 1986.

TI 6310.13A

ASR-8 Technical Instruction Books.
Dated: April 11, 1990.

ICD SE007-4E

External Interface Control Document for the ASR-9 SCIP
to Terminal Computer. Dated: June 13, 1986.

Requirements Document for the Terminal Radar Digitizer
Program. Dated: DRAFT.

Target Data Extractor Model 2000 Technical Description
Dated: August 30, 1995.

3. SYSTEM DESCRIPTION.

The TDX-2000d is a Commercial-Off-The-Shelf (COTS) radar signal and data processing system. It is designed to interface with analog radar and beacon systems to produce digital target reports and digital weather vector reports. The system consists of one Signal Distribution Unit (SDU), two redundant Target Data Extractor (TDX) units, a local and remote Control and Maintenance Console (CMC), and an Uninterruptable Power Supply (UPS).

Analog radar and beacon signals including: normal video, Moving Target Indicator (MTI) video, pre-triggers, Azimuth Change Pulses (ACPs), Azimuth Reference Pulses (ARPs), beacon reply video, and mode pair triggers are input to the SDU. The SDU distributes these signals to the two redundant TDX units for processing. The SDU also receives digital reports from the TDX units and routes this data to the user's modems.

The TDX performs radar and beacon digitizing and target extraction on the video signals. The TDX also performs weather data extraction via a separate weather-processing channel. The TDX then performs processing to limit radar and beacon false reports. Next, the TDX performs radar/beacon reinforcement on the radar and beacon plot messages. The reinforced targets are tracked on a scan-to-scan basis to further filter false radar and beacon targets. The TDX then formats and outputs the radar, beacon, combined radar/beacon, weather, status, and sector mark messages in the required Common Digitizer (CD) format. The processing is performed in both TDX units simultaneously.

The local and remote CMCs provide the user with a graphical interface to control and monitor the TDX subsystems. Operational parameters can be modified to adapt to local conditions and optimize extractor performance. System alarm reporting and fault diagnostics are provided to the user. The CMCs also provide a data recording capability and an integrated radar data analysis package.

The AIU receives digital target reports generated by the TDX-2000d system via modems and supplies reconstituted video and digital data for the ARTS IIA computer and Plan Position Indicator (PPI) displays. The AIU converts the surveillance digital target reports and weather contour digital reports into analog video and timing signals for use as reconstituted video on ATC PPI displays. These signals include: correlated radar video, uncorrelated radar video, beacon reply video, weather video, radar triggers, beacon mode triggers, ACPs, and ARPs.

The AIU also provides serial digital outputs for the ARTS IIA digital input via the Mode Select (Mode S)/ASR-9 Line Adapter (MALA) board. Beacon messages, sector mark messages, status messages, and Real Time Quality Control (RTQC) messages are received by the AIU, reformatted, and then forwarded to the MALA over redundant serial lines.

4. TEST MANAGEMENT.

This section lists the test participants and describes their primary roles and responsibilities. It describes system configuration management and lists the test entrance criteria, test completion criteria, and test objectives. This section also describes the test schedule and test locations involved in the TDX-2000d tests.

4.1 ROLES AND RESPONSIBILITIES.

The principal organizations participating in the extractor evaluation are shown below. Each organization is listed along with their specific roles and responsibilities.

<u>Organization</u>	<u>Primary Roles/Functions</u>
ACT-310	Responsible for the test effort. Will establish a test plan and test schedule. Will participate in technical reviews and meetings. Will design and conduct test activities and analyze data. Will provide a report that presents the results of the test effort.
ACT-540	Will maintain the ASR-8 radar system and the AN/UPX-27 beacon system during the test period. Will certify radar and beacon systems prior to test.
AND-410	Has overall responsibility for the test program. Will direct, manage, and fund activities for the program. Shall be the FAA spokesperson for the test program. Will review test plan. Will witness tests.
AOS-230	Will participate in system optimization and provide technical support during test effort. Will review test plan. Will develop certification procedures based on test results. Will witness tests.
ARN-110	Will review test plan and advise on ATC requirements and issues.
ARN-400	Will coordinate support from regional AF personnel for the tests. Will review test plan and advise on AF requirements and supportability issues.

4.2 CONFIGURATION MANAGEMENT.

The radar and beacon systems will be certified according to established procedures prior to TDX-2000d system installation and optimization. All certification parameters will be documented in the radar site logbook. These parameters will be monitored throughout the test period to verify both radar and beacon systems are operating properly. Standard radar maintenance procedures will be followed during the test period and the radar configuration will be documented prior to data collections.

Sensis personnel will install the TDX-2000d system and AIU at the test locations. Sensis and government personnel will optimize the TDX-2000d and AIU for the site's standard operational radar configuration. These adaptation and optimization parameters will be held constant throughout the test period. Any parameter changes must be approved by the test team and fully documented in the test logbook. The test team must approve any changes to extractor hardware or software during the test period. Any parameter or hardware/software changes that could effect previously collected data sets will warrant regression tests.

Local site technicians will be requested to change the radar configuration (e.g. change between Circular Polarization (CP) and Linear Polarization (LP), log video, etc.) for the different data sets to be collected. These data sets will be used to determine the effect radar configuration changes have on extractor performance. These data sets will be fully defined in test procedures to be developed.

4.3 TEST ENTRANCE CRITERIA.

The following prerequisites shall be met before testing can begin:

- a. The baseline TDX/AIU hardware and software must be installed,
- b. The TDX-2000d system and AIU shall successfully complete all factory acceptance tests,
- c. The TDX/AIU communication lines must be installed and verified,
- d. The TDX/AIU must be optimized according to established procedures,
- e. The TDX/AIU system baseline must be stable with no major modifications likely,
- f. The test plan shall be approved.

4.4 TEST COMPLETION CRITERIA.

The following list of criteria shall be met before testing is considered complete:

- a. All major operational issues listed in the test plan must be investigated,
- b. System evaluations on maintainability must be performed and all operational problems identified must be addressed and resolved,
- c. All integration and operational test objectives must be successfully completed,
- d. All test discrepancy reports generated during testing must be resolved and regression tested.

4.5 TEST OBJECTIVES.

The test effort will provide data to aid in the determination of the effectiveness and suitability of the TDX-2000d system and AIU in NAS. The following major operational issues have been identified for test:

- a. Coverage. Does the TDX-2000d provide the air traffic controller with suitable primary and secondary radar data within the required coverage volume?
- b. False Alarm Rate. Does the number and distribution of false reports from the TDX-2000d allow reliable aircraft detection, identification, and tracking consistent with the ATC mission and airspace safety requirements?
- c. Aircraft Separation. Does the TDX-2000d resolve closely spaced aircraft with sufficient reliability to allow the controller to maintain separation standards?
- d. Reliability, Maintainability, Availability. Is the Reliability, Maintainability, and Availability (RMA) of the TDX-2000d and AIU suitable for incorporation into the NAS when used in an operational environment with the available resources, logistics plan, maintenance procedures, and personnel?
- e. Site Adaptation and Optimization. Do the TDX-2000d and AIU system designs and procedures allow the systems to be optimized, adapted to site conditions, and certified by AF personnel?
- f. NAS Interoperability. Do the TDX-2000d and AIU systems operate effectively within the NAS including the following issues: compatibility with other site equipment, equipment interface, data and signal quality, data capacity and delay?
- g. Safety. Are the TDX-2000d and AIU systems safe to operate and maintain?
- h. Human Factors. Do the TDX-2000d and AIU provide user-friendly interfaces that support operations and maintenance and minimize personnel skill requirements and training time?
- i. Weather Detection and Display. Does the TDX-2000d provide accurate and reliable weather data suitable for safe aircraft routing by ATC?

4.6 TEST SCHEDULE.

Tests will begin following contractor conducted training, approval of the test plan, successful completion of factory acceptance tests, system integration, checkout, and optimization by Sensis and government personnel. An integrated schedule for the testing is shown in appendix A.

4.7 TEST LOCATIONS.

Tests for the TDX-2000d and AIU will be performed at the Technical Center and Dobbins AFB/Atlanta TRACON. The TDX-2000d will be tested on the ASR-8 and AN/UPX-27 at the Technical Center while an AN/GPN-20 and Air Traffic Control Beacon Interrogator Model 4

(ATCBI-4) will be used for testing at Dobbins AFB. The AN/GPN-20 is an Air Force radar similar to the ASR-8 with the exception of the transmitter section. The AN/GPN-20 is equipped with a magnetron type transmitter compared to the ASR-8s klystron transmitter. The stability of the klystron transmitter is slightly greater than the magnetron. This difference should not impact test results.

Integration tests performed at the Technical Center include interface verification as well as several performance tests including: system coverage, target detection, false alarm rate, range and azimuth resolution, positional accuracy, weather detection and processing, beacon performance tests, capacity and delay, and system control. Operational tests performed at the Technical Center will include: RMA, site adaptation and optimization, and human factors.

Tests at Dobbins AFB/Atlanta TRACON are required to completely evaluate the detection performance of the TDX-2000d. The Dobbins AFB location offers an environment with more intensive clutter and weather than the Technical Center. This environment may exacerbate any problems with extractor detection performance and false alarm rates. Integration tests performed at Dobbins AFB will include: system coverage, primary and beacon target detection, primary false alarm rate, beacon false alarm rate, weather detection and processing. Operational tests performed will include RMA, human factors, and site adaptation and optimization. Table 4.7-1 provides an indication where each of the tests will be performed. A summary of resources is shown in appendix B.

TABLE 4.7-1. TEST LOCATION MATRIX

		Technical Center	Dobbins/Atlanta TRACON
6.1	INTEGRATION TESTS		
6.1.1	TDX-2000d to AIU	X	
6.1.2	TDX/AIU to ARTS IIA	X	
6.1.3	TDX-2000d to STARS	X	
6.1.4	TDX/AIU to Power Subsystem	X	
6.1.5	System Coverage	X	X
6.1.6	Primary Target Detection	X	X
6.1.7	Primary False Alarm Rate	X	X
6.1.8	Primary Range and Azimuth Resolution	X	
6.1.9	Primary Positional Accuracy	X	
6.1.10	Weather Detection and Processing	X	X
6.1.11	Beacon Target Detection	X	X
6.1.12	Beacon Splits and False Report Rate	X	X
6.1.13	Beacon Range and Azimuth Resolution	X	
6.1.14	Beacon Positional Accuracy	X	
6.1.15	Beacon Code Validation and Code Accuracy	X	
6.1.16	Capacity and Processing Delay	X	
6.1.17	System Control Operation	X	
6.2	OPERATIONAL TESTS		
6.2.1	Reliability, Maintainability, Availability (RMA)	X	X
6.2.2	Site Adaptation and Optimization	X	X
6.2.3	Human Factors	X	X

4.7.1 Technical Center Configuration.

The Technical Center configuration is shown in figure 4.7.1-1. Building 162 houses the ASR-8 and the AN/UPX-27 beacon interrogator. The ASR-8 sends pre-triggers and azimuth information (ACPs and ARPs) to the AN/UPX-27 to synchronize operation of the two systems. A beacon test set provides the ability to inject Radio Frequency (RF) test targets into the AN/UPX-27 test port. Five land lines carry the ASR-8 and beacon video and timing to the Terminal Laboratory. The lines carry: MTI video, normal video, pre-triggers, ACPs, ARPs, and composite beacon video (video, beacon pre-triggers, and mode pair triggers).

The Terminal Laboratory is designed to provide the flexibility to test or support any existing NAS terminal configuration. The laboratory houses the ARTS IIA and controller Radar Alphanumeric Display Subsystem (RADS) needed for testing. A STARS prototype system is also contained within the laboratory area.

The Laboratory Signal Switching System (LSSS) routes analog ASR-8 and beacon video to the desired location (ARTS IIA, RADS) in the lab. In a typical ARTS IIA configuration, the radar video, beacon video, and timing are input to the ARTS IIA computer. The ARTS IIA performs beacon processing including bracket detection and code extraction, and produces the beacon slashes for display on the RADS. The radar video is not processed by the ARTS IIA but fed directly to the RADS along with the triggers, ACPs, and ARPs.

The ARTS IIA can also accept digital beacon reports via the MALA board interface. With the MALA board interface, beacon processing performed by the ARTS IIA can be bypassed and data can be sent directly to the ARTS IIA tracker.

Radar video, beacon video, and timing signals are also sent to the Sensor Receiver and Processor (SRAP). The SRAP extractor contains a Radar Data Acquisition System (RDAS) and a Beacon Data Acquisition System (BDAS). The RDAS performs the radar data extraction, detection, false alarm control, centroiding, and resolution of primary targets. The BDAS performs the beacon data extraction including: bracket detection, code extraction, garble processing, and defruiting. The SRAP outputs digital radar, beacon, and merged messages to the ARTS IIA Input/ Output Processors (IOPs).

The TDX-2000d system will be located at the ASR-8 radar site. Analog MTI, normal, and beacon videos, ACPs and ARPs, and triggers will be input to the TDX-2000d from the ASR-8 and AN/UPX-27. The TDX-2000d will output radar, beacon, weather, status, and sector mark messages. These messages will be sent via modem to the Terminal Laboratory Bytex Switch. The Bytex switch routes digital data to the desired location.

The AIU and remote CMC for the TDX-2000d will be located in the Terminal Laboratory. The AIU will receive digital data from the Bytex switch. The remote CMC will be connected to the local site via direct Ethernet link. The AIU will provide a digital output for the ARTS IIA MALA board and will reconstitute the video for the ARTS IIA and RADS. The reconstituted radar video, triggers, ACPs, and ARP will sent to the ASR-8 Unit 9. ASR-8 Unit 9 provides remote control of the ASR-8 and signal amplification to drive several RADS.

CD data will be recorded at the output of the TDX-2000d and at the MALA output of the AIU. Parallel digital data will be recorded at the output of the SRAP. This data will be used for performance comparisons of the TDX-2000d and the SRAP.

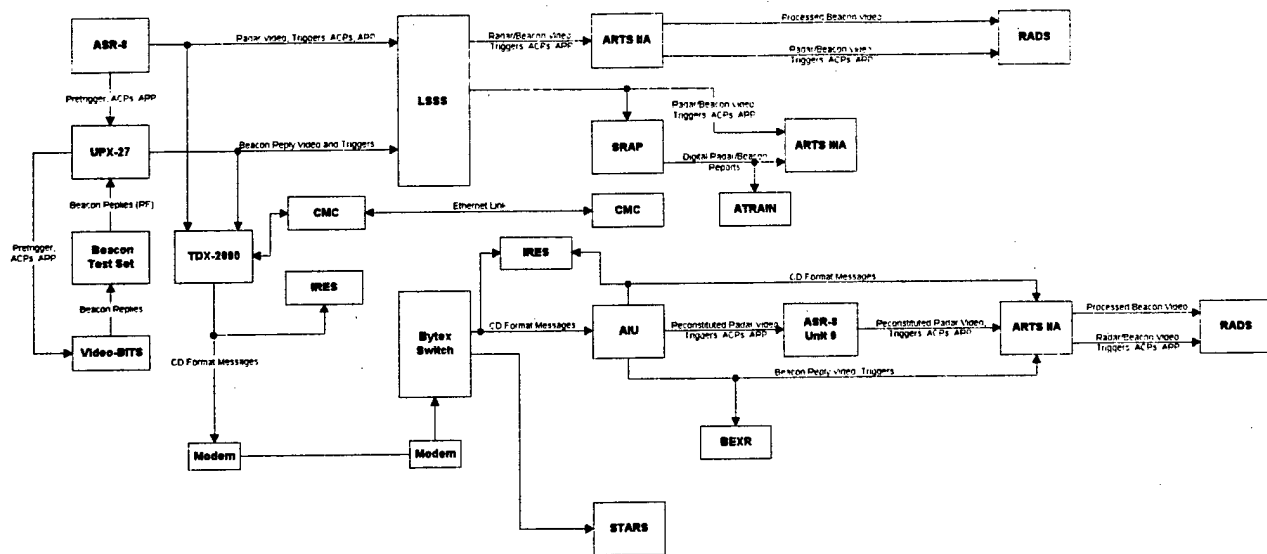

FIGURE 4.7.1-1. TECHNICAL CENTER TEST CONFIGURATION

4.7.2 Dobbins AFB Configuration.

The Dobbins AFB/Atlanta TRACON test configuration is shown in figure 4.7.2-1. The AN/GPN-20 and ATCBI-4 are housed in a trailer at Dobbins AFB. The AN/GPN-20 sends pre-triggers and azimuth information to the ATCBI-4 to synchronize operation of the two systems.

The MTI video, normal video, pre-triggers, ACPs, ARPs, and composite beacon video are compressed with a video compression unit and sent to the TRACON on a T1 data line. The signals are decompressed and the radar video, beacon video, and timing signals are input into the SRAP. The SRAP outputs digital radar, beacon, and merged messages to the ARTS IIIA IOPs.

The TDX-2000d and local CMC will be housed at the Dobbins AFB radar site. Analog MTI, normal, and beacon videos, ACPs, ARPs, and pre-triggers will be input to the TDX-2000d from the AN/GPN-20 and ATCBI-4. The AN/GPN-20 and ATCBI-4 will simultaneously feed the analog video to the video compression unit. The TDX-2000d will output radar, beacon, weather, status, and sector mark messages.

CD data will be recorded at the output of the TDX-2000d. Parallel digital data will be recorded at the output of the SRAP. This data will be used for performance comparisons of the TDX-2000d and the SRAP.

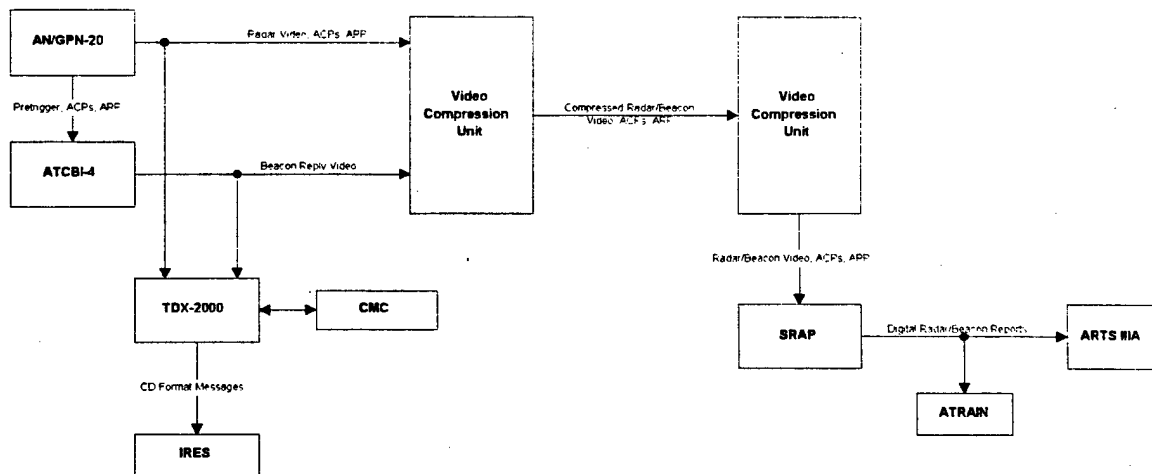

FIGURE 4.7.2-1. DOBBINS AFB/ATLANTA TRACON TEST CONFIGURATION

4.8 DATA RECORDING AND ANALYSIS.

Several methods will be used to record and analyze data during the test period. The CMC of the TDX-2000d supports data recording at several layers within the processing hardware. Raw video amplitude data can be captured within a user-defined range/azimuth region. Detected video replies can be captured for the entire range/azimuth extent. Status data, plot data including data into and out of the Multi-Scan Correlator (MSC), and MSC track data can be recorded. Final report data transmitted to the modems can also be recorded.

The Integrated Radar Evaluation System (IRES) is a personal computer (PC) based tool developed by the Surveillance Branch (ACT-310) at the Technical Center. IRES contains a custom circuit board for data recording primary and secondary surveillance reports and software programs for data conversion and analysis. IRES presents results in tabular or plotted form (histograms, range-azimuth plots). Software analysis programs include a filter program for isolating data of interest, an alpha beta tracker for false alarm analysis, percent detection, resolution, and accuracy analysis programs.

The Radar Beacon Analysis Tool (RBAT) is a PC-based test tool developed by ACT-310 at the Technical Center. RBAT consists of a set of radar and beacon software programs for analysis of CD and Mode S system data extraction files. Results are presented in tabular and plotted form. Analysis programs include coverage, false target identification, track statistics, and accuracy analysis programs.

The ARTS IIIA/Transportable Radar Analysis Computer System (TRACS) Interface (ATRAN) is a PC-based hardware/software system that provides a nonintrusive means for recording the surveillance data messages of the ARTS IIIA facility SRAP. The ATRAN connects in parallel with the normal ARTS IIIA data path into the ARTS IOPs and records the 32-bit parallel data in TRACS format.

The Sensis Beacon Extractor and Recorder (BEXR) is a PC-based test tool that provides a means of recording, displaying, digitizing, and analyzing beacon signals from all-analog systems or from digitized systems prior to decoding and target processing. It performs the initial processing functions required to extract reply data from raw video returns. BEXR also provides the processing required to extract and format target data.

The Sensis Video-Beacon Interrogator Test Set (Video-BITS) is a PC-based tool that simulates the baseband video signals generated by standard ATC Radar Beacon System (ATCRBS) interrogators. This system provides beacon target scenario generation to analyze beacon target processors.

5. DOCUMENTATION.

This section identifies the test documentation and reports that will be generated from the test effort. A description of each document is included.

5.1 TEST PROCEDURES.

Test Procedures will provide the procedures for each test specified in the TDX-2000d Test Plan. These procedures will include the required steps to perform each test. They will indicate the particulars for each test such as objectives, test methods, test configurations, support hardware and software, special test equipment, data collection and analysis methods, etc.

5.2 QUICK LOOK REPORT.

A Quick Look Report will provide a status of tests completed, a list of test discrepancies, and a summary of initial results. The report will be available 14 days after the completion of testing. It will contain initial findings discovered during testing, but will not contain the final results of all tests. These results will be presented in a final report.

5.3 FINAL TEST REPORT.

A Final Test Report will provide the detailed results of the test activities. A draft report will be available 90 days after the completion of testing. The report will contain the specific test objectives, descriptions, requirements, and criteria used for evaluation. It will contain data collection and analysis methods used, along with results for each test. Any system discrepancies found during tests and their relevance to digitized ASR-8 deployment in NAS will be discussed.

6. TEST AND EVALUATION.

The test effort will consist of Integration and Operational tests. Integration tests verify that the TDX-2000d system and AIU correctly communicate with external NAS equipment. Integration tests will also verify the NAS end-to-end performance. Operational Tests evaluate the effectiveness and suitability of the TDX-2000d and AIU when integrated into NAS.

6.1 SYSTEM INTEGRATION TESTS.

6.1.1 TDX-2000d to AIU.

These tests verify that the TDX-2000d reliably transmits data in the proper format to the AIU with sufficient built-in test capability to detect degraded performance. Tests will also verify that the graceful degradation logic of the TDX-2000d operates correctly during overload conditions.

6.1.1.1 User Port Operation.

Purpose

Ensure that the TDX-2000d can physically and functionally interface to user modems.

Objectives

- a. Verify that the TDX-2000d user ports can be configured to support user requirements.
- b. Verify that the clock and data electrical characteristics, as well as timing are in compliance with EIA-RS-232 and EIA-RS-422 standards at varying signal rates.

Description

The TDX-2000d communicates with user modems via Universal Input/Output (UNIO) boards. A maximum of three boards can be installed into each TDX depending on user requirements. Each board provides three serial output channels. Each channel has full modem control logic capability and can be configured for RS-232 or RS-422 electrical standards.

Pulse characteristic measurements will be made at the UNIO output ports. Data and clock signal characteristics to be measured include: voltage, pulse width, rise time, fall time, data transition, and polarity. These measurements will be repeated for both RS-232 and RS-422 standards operating at various baud rates.

Data Collection and Analysis Method

Pulse characteristics will be made with an oscilloscope. One channel of the oscilloscope will be used to measure data signal characteristics while a second channel will be used to measure clock signal characteristics. The two channels will be compared to ensure data levels transition on the correct edge of the clock, and setup and hold times are being observed.

6.1.1.2 Data Format Verification.

Purpose

Ensure that the TDX-2000d reliably transmits all expected message types to the AIU with the correct bit formatting.

Objectives

- a. Verify that the TDX-2000d reliably and accurately transmits all expected message types to the AIU in correct ASR-9 CD format.
- b. Verify that the TDX-2000d consistently reports beacon and search RTQC and status messages to the AIU each scan.
- c. Verify that the TDX-2000d can detect, process, and report civil and military beacon emergencies in the proper format.
- d. Verify that changes in the TDX-2000d status are detected and accurately reported in the status messages sent to the AIU and on the local and remote CMC.

Description

Data will be collected at output ports of the SDU. The TDX UNIO boards will be configured to output ASR-9 CD format messages. Data sources will include targets of opportunity and beacon test targets.

Target of opportunity data will be recorded to verify that the TDX outputs each message type in the correct format. The message types include: search, beacon, sector mark, and weather, messages. The data will also be analyzed to ensure that the beacon RTQC, search RTQC, and status message are correctly output on each scan.

Beacon test targets will be injected into the AN/UPX-27 at RF to verify that bits in the beacon message operate properly and that the TDX properly processes beacon emergencies. Targets will be injected at various ranges and azimuths. Mode 3/A and Mode 2 codes will be chosen to exercise all bits in the beacon message. Target altitudes will be varied to test the Mode C field in the message. Invalid Mode C altitudes will also be injected to verify the TDX properly reports illegal altitudes. In addition, civil and military emergency replies will be injected into the AN/UPX-27 to test the ability of the TDX to process these replies.

To exercise TDX status message bits, configuration changes will be made and/or faults will be injected into the TDX while data is recorded at the user outputs. These configuration changes should be reflected in the status message sent to the AIU.

Data Collection and Analysis Method

All data will be recorded with the IRES RECORD program. This program automatically detects reports that are not ASR-9 CD compatible and reports an error on the reception of these reports. These RECORD indications will be monitored during testing.

Beacon Test Target scenarios will be generated by the Video-BITS. The Video-BITS will modulate the RF generator of the ATCBI-5 beacon test set. The replies, at RF, will then be injected into the AN/UPX-27 RF test port.

IRES PLOTSCAN and COUNTPCS programs will be used to verify that the TDX reported a search RTQC, beacon RTQC, and at least one status message per scan during target of opportunity recordings.

The IRES SHOWPCS program will be used to verify that injected beacon replies produced ASR-9 CD messages with the correct range, azimuth, codes, and emergency bits set.

The IRES SHOWPCS and SHOWSTAT programs will be used to check the recorded status messages to ensure that the expected bits toggled when the TDX configuration was changed or when a fault was injected into the system. The local and remote CMC displays will also be monitored for a status change indication.

6.1.1.3 Degraded Operations.

Purpose

Ensure that the TDX transmits data over the remaining operating modem channels during a modem failure and that priority messages are given preference in transmission during overload conditions.

Objectives

- a. Verify that the TDX can detect a modem failure and redirect data transmission over remaining, operating modem channels.
- b. Verify that priority messages (i.e., beacon emergency, status, RTQCs) are output during overload conditions.
- c. Verify that TDX graceful degradation functionality operates correctly during overload conditions.

Description

Target of opportunity data will be recorded at the output of the TDX. Tests will be performed to verify that the TDX can detect a faulty or unterminated serial port and route data to the remaining operational channels. Data output buffers will be overloaded and data will be recorded to determine that priority messages are output.

Clock signals to the TDX will be interrupted and then restored to simulate modem failures. Handshaking signals to and from the modem will be interrupted to force port failures. Data should be redirected to the remaining available ports.

TDX target threshold levels will be lowered to simulate target overload conditions. This will produce a large number of input targets. Emergency beacon test targets (codes 7700, 7600, and 7500) will be injected using Video-BITS. Data will be recorded and analyzed to ensure all priority messages were output.

Data Collection and Analysis Method

Data will be recorded at the output of the TDX using the IRES RECORD program. The surveillance data will be analyzed using IRES. COUNTPCS will be used to count the number of beacon emergency reports, beacon RTQC, search RTQC, and status messages recorded. SHOWPCS will be used to determine if alarms were reported in the status message reported to the AIU. PLOTSCAN will be used to produce plots of the report counts per scan and produce tables containing data counts. In addition, TDX alarm menus will be monitored to ensure that modem fault and overload conditions are detected and reported by Built in Test (BIT) on the CMC.

6.1.1.4 Modem to Modem Interface

Purpose

Ensure that the local modem communicates properly with the remote modem.

Objective

Verify that the modems provide for the transmission of TDX digital messages to the AIU with a low transmission error rate.

Description

The modems between the TDX and the AIU will be tested to ensure that they are properly strapped and that data transmission across the modem lines is satisfactory. Codex 3600 series modems with optional digital transmission cards will be used to transmit TDX data to the AIU. The configuration and strapping of both modems will be optimized to obtain the best data throughput and quick diagnostic responses.

Block error rate tests and remote loopback tests will be performed to verify modem operation, line quality, and data integrity. During these tests, the transmit and receive modems loop data through each other and compare the returned data.

In addition, to internal diagnostics, data will be recorded at the output of the TDX and at the output of the Terminal Laboratory Bytex switch. The recorded files will then be compared to verify that both files contain the same information.

Data Collection and Analysis Method

During the internal modem diagnostics tests, results are displayed on the front panel of the modem. The error rates will be monitored and recorded for the duration of the tests.

Both data sets will be recorded with the IRES RECORD program. The two data sets will then be compared using the IRES COMPARE program. In addition, the COUNTPCS program will verify that the TDX output the expected RTQC and status messages on each scan.

6.1.2 TDX/AIU to ARTS IIA.

These tests ensure that the TDX/AIU accurately and reliably transmits reconstituted beacon reply video and digital messages to the ARTS IIA and provides suitable reconstituted video for air traffic controller displays.

6.1.2.1 Data Format Verification.

Purpose

Ensure that the AIU reliably transmits all expected message types to the ARTS IIA with the correct bit formatting and with sufficient redundancy.

Objectives

- a. Verify that the AIU outputs messages in the correct CD format to the ARTS IIA MALA board interface.
- b. Verify that the AIU consistently reports beacon RTQCs, status messages, and sector marks to the MALA board on each scan.
- c. Verify that the AIU consistently reports civil and military beacon emergencies in the proper format.
- d. Verify that changes in the AIU status are detected and reported in the status messages sent to the MALA.
- e. Verify there is sufficient redundancy in the AIU to reconfigure the standby channel to on-line when a failure is encountered.

Description

Data will be collected at the MALA output ports of the AIU. The AIU is configured to output CD format messages as defined in the Interface Control Document (ICD) Item SE007-4 for the ASR-9 SCIP to Terminal Computer. Data sources will include targets of opportunity and beacon test targets.

Target of opportunity data will be recorded to verify that the AIU outputs each message type in the correct format. The message types include beacon, search, and sector marks. The data will also be analyzed to ensure that the beacon RTQC and status message are correctly output on each scan.

Beacon test targets will be injected into the AN/UPX-27 at RF to verify that beacon bits in the message operate properly and that the AIU properly reports beacon emergencies. Targets will be injected at various ranges and azimuths. Mode 3/A and Mode 2 codes will be chosen to exercise all bits in those fields in the message. Target altitudes will be varied to test the Mode C field in the message. Invalid Mode C altitudes will also be injected to verify the AIU properly reports illegal altitudes. In addition, civil and military emergency replies (7500, 7600, and 7700 codes) will be injected into the AN/UPX-27 to test the ability of the AIU to process and report these replies.

To exercise AIU status message bits, configuration changes will be made and/or faults will be injected to the AIU while data is recorded at the user outputs. These configuration changes should be reflected in the status message sent to the ARTS IIA.

Data Collection and Analysis Method

Data will be recorded with the IRES RECORD program. This program automatically detects reports that are not CD compatible and reports an error on the reception of these reports. These RECORD indications will be monitored during testing.

Beacon Test Target scenarios will be generated by Video-BITS. The Video-BITS will modulate the RF generator of the ATCBI-5 beacon test set. The replies, at RF, will then be injected into the AN/UPX-27 RF test port.

IRES PLOTSCAN and COUNTPCS programs will be used to verify that the AIU reported a beacon RTQC, and at least one status message per scan during target of opportunity recordings.

The IRES SHOWPCS program will be used to verify that injected beacon replies produced CD messages with the correct range, azimuth, codes, and emergency bits set.

The IRES SHOWPCS and SHOWSTAT programs will be used to check the recorded status messages to ensure that the expected bits toggled when the AIU configuration was changed or when a fault was injected into the system.

6.1.2.2 Video Characteristics.

Purpose

Ensure that the AIU converts surveillance digital target reports and weather contour digital reports into analog video signals that are in an accurate and suitable form for ATC PPI displays.

Objectives

- a. Verify that the AIU generates correlated search, uncorrelated search, beacon reply code, and weather video signals with proper electrical characteristics.
- b. Verify that the AIU generates radar pre-triggers, beacon pre-triggers and mode-pair triggers with proper electrical and timing characteristics.
- c. Verify that the AIU generates ACP and ARP signals with proper electrical characteristics for time alignment of radar, beacon, and weather videos.

- d. Verify that sufficient target range and azimuth extent adjustments exist for both radar and beacon video so that the actual position of the target on the display is contained within the reconstituted video symbol.
- e. Verify that the AIU provides video, azimuth data, and trigger alignment adjustments so that system data processing delays are properly compensated.
- f. Verify correlated radar targets, uncorrelated radar targets, beacon targets, merged targets, and weather levels are output at the correct range and azimuth and can be distinguished on PPI displays.

Description

Characteristics of the video signals will be measured at the output of the AIU. The characteristics to be measured include: amplitude, pulse width, rise time, fall time, overshoot/undershoot, pulse timing, and pulse jitter. These measurements will be performed on both AIU channels.

Beacon test targets will be injected into the AN/UPX-27 at RF and converted to digital messages by the TDX. The digital messages will be transmitted via modems to the AIU. The AIU will generate reconstituted beacon reply video from the digital messages. The reconstituted reply video will be recorded and compared to the original reply video injected into the TDX.

AIU variable site parameters will be analyzed to determine if sufficient adjustments exist to provide an accurate reconstituted video presentation on PPI displays. Range and azimuth extents must be adjustable so that the actual position of the target on the display is contained within the reconstituted symbol used to depict the target. The PPI displays will be monitored to see if targets are reported in the correct position and can be resolved.

Delays for search and beacon video, azimuth data, and trigger alignment must be adjustable so that the system processing delays can be compensated. All analog output signals must be time aligned for simultaneous overlay viewing on the PPI displays.

Data Collection and Analysis Method

An oscilloscope will be used to measure video electrical and timing characteristics. The measured characteristics for both AIU channels will be recorded on data sheets.

Beacon Test Target scenarios will be generated by the Sensis Video-BITS. The Video-BITS will modulate the RF generator of the ATCBI-5 Beacon Test Set. The replies at RF will then be injected into the AN/UPX-27 RF test port.

The Video-BITS test target scenario reply video and the AIU reconstituted reply video will be recorded with the BEXR. These recorded files will be analyzed and compared for differences.

Data results from the primary and beacon accuracy analysis will be used to determine the proper range and azimuth extents for the displayed targets.

6.1.3 TDX-2000d to STARS.

Purpose

Ensure that the TDX-2000d/STARS interface accurately and reliably transmits and processes all expected message types.

Objectives

- a. Verify that the TDX-2000d reliably and accurately transmits all expected message types to the STARS in the correct format.
- b. Verify that the TDX-2000d consistently reports beacon and search RTQC and status messages to the STARS each scan.
- c. Verify that the TDX-2000d can detect, process, and report civil and military beacon emergencies in the proper format.
- d. Verify that changes in the TDX-2000d status are accurately detected and reported in the status messages sent to the STARS.

Description

Data will be collected at output ports of the SDU to verify the TDX-2000d outputs messages in the correct format. Data will also be collected with the STARS data extraction tools. The TDX UNIO boards will be configured to output ASR-9 CD format messages. Data sources will include targets of opportunity, search test targets, and beacon test targets.

Target of opportunity data will be recorded to verify that the TDX outputs each message type in the correct format. The message types include: search, beacon, sector mark, and weather messages. The data will also be analyzed to ensure that the beacon RTQC, search RTQC, and status message are correctly output on each scan.

Beacon test targets will be injected into the AN/UPX-27 at RF to verify that bits in the beacon message operate properly and that the TDX properly processes beacon emergencies. Targets will be injected at various ranges and azimuths. Mode 3/A and Mode 2 codes will be chosen to exercise all bits in the beacon message. Target altitudes will be varied to test the Mode C field in the message. Invalid Mode C altitudes will also be injected to verify the TDX properly reports illegal altitudes. In addition, civil and military emergency replies will be injected into the AN/UPX-27 to test the ability of the TDX to process the replies.

To exercise TDX status message bits, configuration changes will be made and/or faults will be injected into the TDX while data is recorded at the user outputs. These configuration changes should be reflected in the status message sent to the AIU.

Data Collection and Analysis Method

Data will be recorded with the IRES RECORD program. This program automatically detects reports that are not ASR-9 CD compatible and reports an error on the reception of these reports. These RECORD indications will be monitored during testing.

Beacon Test Target scenarios will be generated by the Video-BITS. The Video-BITS will modulate the RF generator of the ATCBI-5 beacon test set. The replies, at RF, will then be injected into the AN/UPX-27 RF test port.

IRES PLOTSCAN and COUNTPCS programs will be used to verify that the TDX reported a search RTQC, beacon RTQC, and at least one status message per scan during target of opportunity recordings.

The IRES SHOWPCS program will be used to verify that injected beacon replies produced ASR-9 CD messages with the correct range, azimuth, codes, and emergency bits set.

The IRES SHOWPCS and SHOWSTAT programs will be used to check the recorded status messages to ensure that the expected bits toggled when the TDX configuration was changed or when a fault was injected into the system. The local and remote CMC displays will also be monitored for a status change indication.

6.1.4 TDX/AIU to Power Subsystem.

Purpose

Determine the impact that power interruptions have on the TDX-2000d system, AIU, communications, and on the data being sent to the end users.

Objectives

- a. Verify that the TDX-2000d and AIU provide a means for maintaining any critical data necessary to restore the system to normal operation is an acceptable time following restoration of power when a power loss occurs.
- b. Verify that the restoration of normal operation is automatic and that all operational programs, fixed and dynamic maps, and site adjustable parameters are preserved.

Description

Tests will be performed to determine the impact that power interruptions have on both the TDX and AIU. Tests will also determine how long the UPS can maintain TDX-2000d operation. Tests will be conducted by interrupting power to the equipment for a short term (i.e., less than 15 seconds), and for a long term. Following restoration of power, the amount of time needed to restore normal operation will be noted. Any alarms that remain in the system after recovery will be noted on the TDX and AIU CMC.

Data will also be recorded at the output ports of the TDX and the AIU during the power interruptions. This data will be analyzed to determine if any false reports were output to the user. The data will also be analyzed to determine the amount of time the TDX and AIU required to restore operation and output data to the user.

Data Collection and Analysis Method

The reaction of the TDX and AIU to short-term and long-term power interruptions will be observed. Any anomalies noted during the events will be documented in the test logbook. Any BIT alarms displayed on the CMC will be recorded. These observations will be correlated with recorded data.

Data will be collected with the IRES RECORD program. The COUNTPCS program will be used to determine report counts before and after power loss events. The SHOWPCS and SHOWSTAT programs will be used to monitor the status message output to the user.

6.1.5 System Coverage.

Purpose

Ensure that the TDX-2000d provides acceptable detection capability throughout the coverage volume.

Objective

- a. Verify that the TDX-2000d detects and reports radar and beacon targets through 360° in azimuth.
- b. Verify that the TDX-2000d slant range coverage is from 0.5 to 55 nautical miles (nm).
- c. Verify that the elevation reporting coverage is from 0 to 30° with respect to the horizontal plane tangent to the earth at the radar antenna.
- d. Verify that that the beacon altitude coverage extends to 60,000 feet above ground level (AGL).

Description

Targets of opportunity will be recorded at the output ports of the TDX-2000d. Data will also be simultaneously recorded at the output of the SRAP. This data will be analyzed and compared to determine the elevation and range coverage throughout all azimuth sectors. Direct observation by the test team of live aircraft data at both test sites will verify that targets are reported at all locations.

Data Collection and Analysis Method

Data will be recorded at the extractor using the IRES RECORD program. Data will be recorded at the SRAP with the ATRAIN program. The ATRAIN data will be converted to IRES format using the IRES COPYCD program.

Coverage analysis will be performed using IRES. The data will first be sorted into range, azimuth, and height order for each scan using the PREPPCS program. The data will next be tracked using TRACK, an alpha-beta tracker in IRES. The QUALIFY program will compare the resultant tracks to a predetermined set of criteria (e.g., minimum track age, minimum distance traveled, percent beacon, etc.) to determine the status of each track (true, false, or unknown).

The FILTER program will separate the track data into true and false track files. The true track file will be used for coverage analysis. True track data will be plotted using the PLOTPCS and PLOTRHI programs. PLOTPCS presents a PPI plot of range versus azimuth. These plots present the minimum and maximum range of coverage at all azimuth angles. PLOTRHI plots reports in a range versus height format. The radar antenna height and 4/3-earth curvature will be taken into account.

6.1.6 Primary Target Detection.

Purpose

Ensure that the TDX-2000d can detect a small Radar Cross Section (RCS) aircraft in the clear, in areas of strong clutter, and in the presence of light precipitation (National Weather Service level 1 and level 2).

Objectives

- a. Verify that the digitized TDX-2000d can detect a small RCS aircraft at least 80 percent of the time at distances from 0.5 to 55 nm.
- b. Determine the detection performance of the TDX-2000d with a small RCS aircraft flying over areas of strong clutter (i.e., mountains, sea, and roads) and/or in areas of light precipitation.

Description

The primary detection performance of the TDX-2000d will be measured through dedicated flights at the Technical Center and the Dobbins AFB site. The configuration (i.e., user configurable parameters) of the extractor will remain constant during detection flights.

Detection flights will be performed using a small RCS aircraft. Radial flights will be performed to measure the peak of beam detection performance. The aircraft will fly radials from radar range zero to maximum range at an altitude intersecting the peak of the radar beam at maximum range. The azimuth radials chosen will include traversal over areas of strong mountain clutter, sea clutter, and roads. Tangential flights will consist of flying one aircraft in patterns over areas of strong clutter. The specific radial and tangential routes will be dependent on local site geography. Flights during atmospheric ducting conditions and fast moving weather will be scheduled as the opportunity presents itself.

Target detection in weather will be measured through dedicated radial flights in light precipitation. Any problems with TDX-2000d detection performance will be exacerbated in light precipitation (i.e., when the strength of the weather return is comparable to the strength of the aircraft return).

The detection tests should be performed in several radar operating modes; e.g., linear and circular polarization. The configuration of the radar during the flight tests will have to be coordinated with local Air Traffic (AT) and AF personnel.

Data Collection and Analysis Method

Data will be recorded at the output ports of the TDX-2000d with the IRES RECORD program. Data will also be simultaneously recorded at the output of the SRAP. The data recorded at the SRAP will be converted to IRES format with the COPYCD program.

Data reduction and analysis will be performed with IRES. First, each recorded file will be filtered with the IRES FILTER program to keep only the data around the radial of interest. The data will next be sorted into range, azimuth, and height order using the PREPPCS program.

Flight test aircraft will then be tracked using the SELECT program, a selective alpha-beta tracker in IRES. SELECT initiates track on the beacon code of interest, but updates tracks on search or beacon reports. PLOTPD will present detection results in the form of radar and beacon detection histograms.

6.1.7 Primary False Alarm Rate.

Purpose

Ensure that the false alarm rate from the TDX-2000d is acceptably low to allow reliable detection, identification, and tracking consistent with the ATC mission and airspace requirements.

Objectives

- a. Verify that the TDX-2000d minimizes false target declarations from clutter types including ground, weather, road and surface traffic, birds, second time around clutter, second time around targets, interference, sea clutter, and anomalous propagation.
- b. Verify that the TDX-2000d clutter mapping recognizes areas of strong clutter (land, weather, etc.) and automatically adapts to the environmental conditions in these designated areas.

Description

Targets of opportunity will be recorded at the output ports of the TDX-2000d and at the output of the SRAP. Recordings will be performed with and without the correlation function of the TDX operating. The data will be analyzed to determine the false alarm rate of the TDX-2000d in both modes of operation.

The adverse effects of a strong clutter or a heavy moving weather environment may cause the extractor to output an excess number of false reports. Target of opportunity data will be analyzed to assess the effectiveness of the extractor clutter and Constant False Alarm Rate (CFAR) processing and the scan-to-scan correlation filter in limiting the number of false reports sent to the automation computers.

Data Collection and Analysis Method

Data will be recorded at the output of the TDX-2000d at both test locations using the IRES RECORD program. Data will be recorded at the SRAP with the ATRAIN program. The ATRAIN data will be converted to IRES format using the COPYCD program.

The data will be analyzed using the IRES Track Quality Assessment (TQA) programs. The data will first be tracked using TRACK, an alpha-beta tracker in IRES. The QUALIFY program will then compare the resultant tracks to a predetermined set of criteria (e.g., minimum track age, minimum distance traveled, percent beacon) to determine the status of each track.

The PLOTTQA track editor program will be used to verify that the true and false status assigned to the tracks by QUALIFY is correct. Also, the unknown tracks will be manually reclassified as true or false after further study using PLOTTQA. The COUNTTRK program will produce true and false report counts.

The FILTER program will be used to separate the true and false reports into different files. The false reports will be plotted in a PPI format. The location of the false reports will then be compared with local maps of the radar site to look for a correlation between false reports and clutter in the local area. False reports will also be compared with weather returns in the recorded data to identify false alarms caused by weather clutter breakthrough in the target channel.

6.1.8 Primary Range and Azimuth Resolution.

Purpose

Verify that the TDX-2000d detects closely spaced aircraft with sufficient reliability to allow the controller to maintain separation standards.

Objectives

- a. Verify that the TDX-2000d resolves with an 80-percent probability, two unequal sized Swerling 1 targets separated by 0.16 nm in range and at the same azimuth at any point in the coverage volume.
- b. Verify that the TDX-2000d resolves with an 80-percent probability, two unequal sized Swerling 1 targets at the same range and separated in azimuth by 2.8° at any point in the coverage volume.

Description

Dedicated flights using two closely spaced aircraft of different radar cross section will be performed at the Technical Center to assess the effectiveness of the TDX resolution algorithms. The aircraft will fly two distinct scenarios: a range resolution scenario, and an azimuth resolution scenario.

The range resolution scenario will consist of flying the two aircraft in a single holding pattern. The holding pattern will be a racetrack shaped pattern with each of its legs positioned along a radial to the radar. The lead aircraft will fly at constant speed in the pattern. The trail aircraft will follow the lead aircraft along the same azimuth at a slightly different altitude. At the direction of personnel at the radar site, the trail aircraft will repeatedly overtake, then fall behind, the lead aircraft in order to maximize range resolution samples.

The azimuth resolution scenario will consist of flying the two aircraft in separate, parallel racetrack patterns. The aircraft will be separated in azimuth by approximately two antenna beamwidths. One aircraft will fly at constant speed in its pattern. The second aircraft, with direction from personnel at the radar site, will adjust its speed, as needed, to ensure that the two aircraft maximize their time at the same range from the radar.

Each aircraft will be equipped with a Global Positioning System (GPS) receiver to obtain true positional data. GPS data will be recorded aboard each aircraft. The GPS data from each aircraft will be differentially corrected to obtain a specified positional accuracy of 5 meters. These differential corrections will be obtained from a GPS base station located at the surveyed, ASR-8 site at the Technical Center (Building 162).

Data Collection and Analysis Method

Data will be recorded at the output ports of the TDX-2000d with the IRES RECORD program. Data will also be simultaneously recorded at the output of the SRAP with the ATRAIN program. The data recorded at the SRAP will be converted to IRES format with the COPYCD program.

Data reduction and analysis will be performed with IRES. The IRES TRACK program will track the two aircraft of interest. Next, the tracked target reports will be merged with the GPS data by the MERGEPCS program. The percent resolution will then be computed based on the GPS reported separation and the existence of one (no resolution) or two (targets resolved) radar reports. The PLOTRES program will present resolution results in the form of radar detection histograms.

6.1.9 Primary Positional Accuracy.

Purpose

Determine that the TDX-2000d's primary positional accuracy is sufficient for operational use.

Objectives

- a. Verify that the TDX-2000d provides single scan primary range surveillance information that is accurate to 380 feet RMS (1/16 nm) within the entire detection envelope.
- b. Verify that the TDX-2000d provides single scan primary azimuth surveillance information that is accurate to 0.264° within the entire detection envelope.

Description

Data from the azimuth resolution testing will be used in the accuracy analysis. The flight test scenarios are described in the Primary Range and Azimuth Resolution section of this test plan. During the test, data will be collected from each GPS equipped aircraft and the GPS ground station. The differentially corrected GPS data (accurate to within 5 meters) will be used as the source of positional truth in the accuracy analysis.

Data Collection and Analysis Method

Data will be recorded at the output ports of the TDX-2000d with the IRES RECORD program. Data will also be simultaneously recorded at the output of the SRAP with the ATRAIN program. The data recorded with ATRAIN will be converted to IRES format with the COPYCD program.

The data will be tracked with the IRES selective alpha-beta tracker program SELECT. The tracked target reports will then be merged with GPS data based on time with the MERGEPCS program. Histograms showing range and azimuth errors between the radar and reference reports will be generated with the COLRB program.

6.1.10 Weather Detection and Processing.

Purpose

Verify that the TDX-2000d can provide acceptable weather data to the user for AT advisories.

Objectives

- a. Verify that the reconstituted weather video product from the AIU is comparable to the weather contours displayed from the analog ASR-8.

- b. Verify that the TDX-2000d weather contours are comparable to weather contours from a reference source.

Description

PPI displays from the analog ASR-8 and digitized ASR-8 will be simultaneously viewed to compare the weather display of the two systems. One ARTS IIA system will pass analog video and triggers directly to RADS displays. The reconstituted video from the AIU will feed another RADS display. The test team will compare the weather presentations on the adjacent displays.

Digital reports will also be recorded simultaneously at the output of the TDX-2000d and the output of the test ASR-9 at the Technical Center. The ASR-9 will serve as a source of truth data for comparison. The TDX and ASR-9 files will be plotted and compared. This comparison should not be considered a detailed analysis of the TDX weather product. This analysis will only be a general comparison of the contours and levels with existing terminal radar weather products.

Data Collection and Analysis Method

The test team viewing adjacent analog displays will compare the TDX-2000d weather products to analog ASR-8 presentation. Anomalies will be documented in the test logbook.

Data will be recorded at the output of the TDX and ASR-9 with the IRES RECORD program. The FILTER program will be used to isolate the weather messages from the files. Plots of the weather contours will be generated with the PLOTWX program.

6.1.11 Beacon Target Detection.

Purpose

Ensure that the TDX-2000d beacon processor provides detection performance throughout the coverage volume.

Objectives

- a. Verify that the detection performance of the TDX-2000d beacon processor meets or exceeds the performance of existing SRAP beacon processor.
- b. Verify that the beacon probability of detection, for targets with a round reliability of 0.75, is 99.5 percent based on the following conditions:
 1. Three-fourths of the modes responding (e.g., modes 3/A, C, 3/A responding from a 3/A, C, 3/A, C interlace pattern).
 2. In a steady state condition of 10,000 False Replies Unsynchronous In Time (FRUIT) replies per second.

Description

Target of opportunity data and data collected during the Primary Target Detection tests will be used to evaluate beacon detection performance. The test aircraft, previously described in the Primary Target Detection tests, will be transponder equipped to provide the reply data needed for beacon detection analysis. Test target scenarios will be injected into the AN/UPX-27 at the Technical Center to further evaluate beacon detection performance.

Data Collection and Analysis Method

Dedicated flight data and target of opportunity data sets will be recorded at both radar sites using the IRES RECORD program. Data will be analyzed using IRES and RBAT. The Primary Target Detection section of this plan describes the collection and analysis methods used in evaluating detection performance.

In addition to dedicated flight data analysis, beacon test target scenarios will be used to test the beacon processor. Tests will be conducted at the Technical Center. Video-BITS will modulate the RF generator of the ATCBI-5 beacon test set. The RF replies will then be injected into the AN/UPX-27 RF test port. Beacon messages will be recorded at the output of the TDX-2000d. Files will be analyzed using IRES. Injected test targets will be used for any tests that dedicated flights cannot support. These tests require control of specific parameters such as FRUIT rates, transponder power levels, round reliability, and target spacing.

Test target data will be recorded and analyzed using IRES RECORD program. The data will be sorted into range, azimuth, and height order using the PREPPCS program. Test target data will then be tracked using the SELECT program. PLOTPD program will present detection results in the form of radar and beacon detection histograms.

Data will also be analyzed using RBAT. The FILTER, and BEACON and RADAR COVERAGE programs will be used to provide plots and listings of beacon coverage. The generated plot files will present altitude and elevation data in Range, Height, Indicator (RHI) format.

6.1.12 Beacon Splits and False Report Rate.

Purpose

Ensure that the performance of the TDX-2000d beacon system is within acceptable limits for operation in NAS and that the extractor effectively rejects false beacon replies.

Objectives

- a. Verify TDX-2000d beacon false target processing is effective in eliminating false beacon replies while not eliminating real replies.

- b. Verify that the TDX-2000d produces no more than one false beacon target report per scan in a steady state condition of 10,000 ATCRBS replies per second.

Description

This test evaluates the effectiveness of the TDX-2000d reply processor and plot extractor in detecting and processing replies. Performance will be evaluated through analysis of target of opportunity and test target data collected at the Technical Center and Dobbins AFB. Extractor output will be analyzed for splits, multipath, and ring-around. Test targets scenarios will include injection of FRUIT. FRUIT rates will be varied using a beacon test set to determine the effectiveness of the defruiter.

Data Collection and Analysis Method

Targets of opportunity data will be recorded at the output of the TDX-2000d using the IRES RECORD program. Data will also be simultaneously recorded at the output of the SRAP with the ATRAIN program. Data will be collected at different times during the test period to provide samples of data that represent different environmental conditions. ATRAIN files will be converted to IRES format with the COPYCD program. Each recorded data file will be analyzed using IRES and RBAT.

Beacon test target scenarios will be generated by Video-BITS. Video-BITS will modulate the RF generator of the beacon test set. Replies will then be injected into the AN/UPX-27 RF test port. Beacon messages will be recorded at the output of the TDX-2000d. Files will be analyzed using IRES and RBAT.

The PREPPCS and FILTER programs will be used to sort, tag, and separate false beacon reports. The COUNTPCS program will be used to count the number of false beacon reports on each scan. The PLOTPCS program will be used to plot only the split reports.

The RBAT FILTER and BEACON FALSE TARGET SUMMARY programs will be used to provide plots and listings of splits, ringaround, and reflection data. The generated list and plot files will present tabular and graphical false target results.

6.1.13 Beacon Range and Azimuth Resolution.

Purpose

Ensure that the TDX-2000d beacon processor resolves closely spaced beacon replies in range and azimuth.

Objectives

- a. Verify that the TDX-2000d resolves noninterfering (nonoverlapping) beacon targets 95 percent of the time when at the same center azimuth and separated by 0.05 to 0.5 nm in range inclusive.
- b. Verify that the TDX-2000d resolves noninterfering beacon targets 99 percent of the time when separated by more than 0.5 nm in range.
- c. Verify that the TDX-2000d resolves two detected, stationary, identical targets at least 95 percent of the time which are within 0.5 nm in range and separated by an absence of beacon replies for 18 Pulse Repetition Time (PRT).
- d. Verify that the TDX-2000d resolves two detected noninterfering, stationary or moving targets which are within 0.05 nm in range and have one or more distinguishing characteristics at least 99.5 percent of the time. Distinguishing characteristics include different Mode 2, 3/A, or C codes.

Description

Dedicated flights using two closely spaced aircraft will be performed at the Technical Center to assess the beacon resolution performance of the TDX. The aircraft will fly two distinct scenarios: a range resolution scenario, and an azimuth resolution scenario. These scenarios are described in the Primary Range and Azimuth Resolution section of the test plan.

Beacon resolution performance will also be tested by injecting closely spaced beacon replies into the TDX-2000d and varying the code pulse and bracket overlap of the replies. Range test target scenarios will include reply trains spaced closely in range, and code pulses that overlap in azimuth by varying amounts. Azimuth test target scenarios will include identical target pairs at the same range varying in azimuth separation, and, adjacent (no PRT separation) target pairs with one distinguishing difference between targets.

Data Collection and Analysis Method

Data will be recorded at the output ports of the TDX-2000d with the IRES RECORD program. Data will also be simultaneously recorded at the output of the SRAP with the ATRAIN program. The data recorded at the SRAP will be converted to IRES format with the COPYCD program.

Data analysis will be performed with IRES. The IRES TRACK program will track the aircraft of interest. The tracked target reports will be merged with the GPS data by the MERGEPCS program. The percent resolution will then be computed based on the GPS reported separation. The PLOTRES program will present resolution results in the form of radar detection histograms.

Range and azimuth test target scenarios will be generated using Video-BITS. Video-BITS will modulate the RF generator of the beacon test set. Replies will then be injected into the AN/UPX-27 RF test port. Beacon messages will be recorded at the output of the TDX-2000d with the IRES RECORD program. SHOWPCS and COUNTPCS programs will be used to count the number of beacon reports output on each scan and inspect the codes in the reports.

6.1.14 Beacon Positional Accuracy.

Purpose

Ensure that the performance of the TDX-2000d beacon processor accurately reports range and azimuth position.

Objectives

- a. Verify that the TDX-2000d standard deviation range errors do not exceed 0.03125 nm (190 feet).

- b. Verify that the TDX-2000d azimuth error does not exceed 1/10 of the antenna's 3 decibel (dB) azimuth beamwidth.

Description

Data from the azimuth resolution test will be used in the accuracy analysis. The flight test scenarios are described in the Primary Range and Azimuth Resolution section of this test plan. During the test, data will be collected from each GPS equipped aircraft and the GPS ground station. The differentially corrected GPS data (accurate to within 5 meters) will be used as the source of positional truth in the accuracy analysis. During analysis, the TDX-2000d reported positions will be compared to the GPS reported positions to determine the range and azimuth accuracy of the extractor data.

Data Collection and Analysis Method

During the flights, data will be recorded at the TDX-2000d and at the SRAP outputs using IRES RECORD and ATRAIN programs, respectively. ATRAIN files will be converted to IRES format with the COPYCD program. The recordings will be time correlated with the GPS data.

The accuracy analysis will be performed using IRES. Each data set (TDX and SRAP output) will be analyzed separately. The data will be tracked using TRACK program. The tracked target reports will then be merged with GPS data based on time. A linear interpolation will be performed between adjacent GPS reported positions to provide a continuous positional reference. The range and azimuth accuracy of the messages will be determined through comparison with the GPS reported (or interpolated) positions.

6.1.15 Beacon Code Validation and Code Accuracy.

Purpose

Ensure that the TDX-2000d beacon processor reports accurate beacon codes with a high validation rate.

Objectives

- a. Verify that the TDX-2000d validates the beacon code information as contained in the aircraft's reply for Modes 2, 3/A, and C including Special Position Identification (SPI) and X-bit pulses at least 95 percent of the time when five or more hits are received per mode.
- b. Verify that the TDX-2000d validates the beacon code information as contained in the aircraft's reply for Modes 2, 3/A, and C including SPI and X-bit pulses at least 98 percent of the time when the number of actual hits received per mode is 11 or greater.
- c. Verify that the TDX-2000d effectively detects and resolves phantom replies and garble cases, and that military and civilian emergency replies are properly processed.
- d. Verify that the validated codes are accurate at least 99 times out of 100.
- e. Verify that the validation of incorrect codes due to FRUIT or other causes occurs < 1.0 percent.

Description

The code validation and code accuracy performance of the TDX-2000d will be evaluated through analysis of injected test targets and targets of opportunity. The test target scenarios will test all reply bits at different runlengths and phantom cases (e.g., that occur in the closely spaced reply condition when nonframing pulses in different replies occur at the framing interval). Target of opportunity data will be collected throughout the test period to identify beacon processor limitations such as; invalid codes and splits. Test target tests will be conducted at the Technical Center. Target of opportunity tests will be conducted at the Technical Center and at Dobbins AFB.

Data Collection and Analysis Method

Beacon test target scenarios will be used to verify the performance of the beacon processor. Video-BITS will modulate the RF generator of the ATCBI-5 beacon test set. The RF replies will then be injected into the AN/UPX-27 RF test port. Beacon messages will be recorded at the output of the TDX-2000d using IRES RECORD program.

Target of opportunity data will be recorded at the output of the TDX-2000d. SHOWPCS and COUNTPCS programs will be used to inspect the beacon report codes and count the number of reports with the correct and validated codes.

6.1.16 Capacity and Processing Delay.

Purpose

Ensure that the TDX/AIU can adequately process and output a capacity target load within a specified delay time.

Objectives

- a. Verify that the TDX-2000d and AIU can process and provide message outputs for a steady state maximum load of 700 aircraft returns within the primary coverage area.
- b. Verify that the TDX-2000d can process and provide message outputs for a load of 250 aircraft returns uniformly distributed in a 90° sector.
- c. Verify that the TDX-2000d can process and provide message outputs for a load of 100 aircraft returns uniformly distributed across two contiguous 11.25° sectors.
- d. Verify that the TDX-2000d can process and provide message outputs for a small sector peak consisting of 16 aircraft returns in each of two contiguous 1.3° wedges.
- e. Verify that the total delay, or throughput time, from detection of a target at the antenna boresight to output at the controller display of the target report shall not exceed 2.2 seconds.

Description

Capacity scenarios of search and beacon targets will be injected into the TDX-2000d. The search and beacon test target generators of the TDX will be used to inject the test targets. Data will be recorded and time tagged at the output of the TDX and the AIU.

To measure target delay, sector mark messages generated by BEXR will be input into the data stream along with the target reports. BEXR will be triggered by the ARP signal from the ASR-8, thus giving an antenna azimuth reference to the generated sector marks, which are input to a dedicated record channel.

The ARP signal will also be sent to a logic analyzer along with the generated sector marks. The logic analyzer will measure the latency between the ARP and the sector mark zero to determine the BEXR delay in generating the sector marks. This measured delay will be subtracted from report delay calculations during analysis.

Data Collection and Analysis Method

Data will be recorded simultaneously at the output ports of the TDX-2000d and the MALA output of the AIU with the IRES RECORD program. The two record PCs will be time synchronized.

Report counts from the recorded files will be compared to the expected inputs from the test target generators for capacity analysis. The IRES COUNTPCS and SCANSUM programs will produce report counts per scan. The PLOTSCAN program will produce a graph of report counts per scan.

The CMPDELAY and DELAY programs will be used for delay analysis. CMPDELAY will compute the delay of each report. A linear interpolation using report azimuth and time will be performed on all reports. Consecutive sector marks will be used for the true azimuth reference in the calculation.

The DELAY program will generate a histogram plot showing the distribution of report delays relative to the boresight of the radar antenna.

6.1.17 System Control Operation.

These tests ensure that the local and remote CMC provide the means to control and maintain the TDX-2000d and AIU and provide sufficient performance information to the user.

6.1.17.1 Local and Remote CMC Terminal Operations.

Purpose

Ensure that the CMC can reliably provide control and status to facilities personnel.

Objectives

- a. Verify that the operator has the ability to fully control extractor operation at the local and remote locations.
- b. Verify that the operator has sufficient control of extractor adjustable parameters, performance statistics, and display of surveillance data.

Description

There are five basic areas of the CMC graphical interface and control; Mode Select, Options Select, Tabular Display, PPI, and MSC Status Lights & Status Icon. The Mode Select area contains the menus that provide the operator with system control, configuration, and statistical information. The Options Select area contains the menus necessary to adapt the extractor to site equipment and conditions, and provides the operator the ability to control CMC presentation. The PPI area displays surveillance data based on range and azimuth or RHI, and provides features necessary to display PPI information, maps, and overlays. The MSC Status Lights & Status Icon area presents MSC fault status and communications information.

Each menu will be exercised to its full capability at the local and remote CMC. All menus will be examined for control, feedback, and display features. Menus will be checked for ease of operation and functional use.

The ability to change the configuration (e.g., change on-line channels) or operating parameters will be tested at the local and remote CMC. Both CMCs will be monitored to verify that the action taken produced the expected results. Fault detection and isolation procedures will be executed from each CMC. Local and remote CMC displays will be compared for accuracy and content.

Data Collection and Analysis Method

Menus that display incorrect information will be documented in the test log book. Parameters that do not adjust over their full range of values will be identified and logged. Logbook entries will be supplemented with; hard copies of menu and PPI screens, data collected to the hard disk (screen dumps, etc.), and statistical information collected from all functional areas.

A direct comparison of CMCs will be made with personnel located at the local and remote locations during the testing period. Performance statistics menus and PPI presentation will be compared for accuracy at each location. Stored MSC Daily Statistics, representing statistics of the MSC for a single day of operation, will be compared for the local and remote CMC and the differences will be documented.

6.1.17.2 Equipment Performance.

Purpose

Ensure that the TDX-2000d can provide accurate status, configuration, and performance information to the operator.

Objectives

- a. Verify proper operation of the TDX-2000d hardware and software that allows for switching and control of on-line channels or redundant elements.
- b. Verify that the TDX-2000d provides the necessary hardware and software parameters to display, edit, and control the operational equipment and properly configure the system to the needs of a unique site.
- c. Verify that the TDX-2000d automatically detects and displays equipment status.

Description

Equipment performance is provided within the PPI area Air Situation Display (ASD), which provides graphical and tabular information. Graphical data in the ASD Display will be checked for content and accuracy. General ASD operation will be verified including; cursor operation, display resizing, PPI and RHI display, and other operator options. Graphical symbols, geographical maps, and overlays will be verified. Surveillance plot data and weather will be viewed for presentation and correctness, and the Tabular Display area's tabular track data will be checked.

System startup and shutdown procedures will be validated. Password control, software installation, and hard disk maintenance will be examined. Use of the ASR-8 control panel in conjunction with the extractor controls will be examined to determine the effectiveness of the user interface.

AIU modes of operation will be checked including on-line, startup configuration, and off-line utility modes. On-line mode is the only mode that permits incoming target data to be processed and sent to the ARTS. Startup configuration mode allows operator entry of site adjustable parameters. Off-line utility mode is used for software updates and data analysis. Procedures for startup and shutdown will be checked. All operator controls will be exercised including; reset, printer error logging, error data dump, and data collection.

Data Collection and Analysis Method

System operational and maintenance checks will be performed and logged during the testing period to ensure that the TDX-2000d and AIU are operating within established parameters. Performance statistics from each functional area will be analyzed to validate the modes of operation and operating parameters.

Procedures for TDX-2000d startup and shutdown will be executed. System responses will be compared with expected results. Any operator action that results in an unexpected 'cold' or 'warm' boot will be identified. Procedures for installing operational and CMC software will be executed and any unexpected problems will be documented.

All system control features will be evaluated by operating the extractor in every mode and configuration. Emphasis will be placed on the ability of the extractor to inform the operator of complete system status. Incomplete, incorrect, or conflicting status will be documented.

The operational features of the AIU will be examined by performing all control and operational functions at the AIU keyboard and display. Front panel status will be compared to display menu information and any discrepancies will be documented. AIU parameters will be verified by changing parameter values (maximum and minimum extent) and documenting the actual responses. Responses will be compared with expected results and any discrepancies will be investigated.

6.1.17.3 Alarm Reporting and Fault Isolation.

Purpose

Ensure that the TDX-2000d and AIU can detect and display equipment faults and provide a means to isolate hardware and software failures.

Objectives

- a. Verify that the TDX-2000d detects faults, and accurately reports alarm status in a timely manner.
- b. Verify that maintenance personnel are able to detect/isolate faults and restore TDX-2000d operation within maintenance guidelines.

Description

These tests will ensure that the MSC Status Lights area of the display indicate the correct status of the MSC by exercising the Command Correct, Bypass, Correlate, and Fault indicators. Fault and status indications at each CMC, TDX, and AIU will be compared for consistency and content. The Status Icon portion of the display will be viewed for status, error, and warning messages that are available in the status log window. Tests will also ensure that a complete list of alert, warning, and status messages are processed, logged, and displayed by the MSC.

Field level corrective maintenance tasks required because of component or assembly failure will be verified. Periodic and special maintenance checks will be evaluated. Fault detection and isolation procedures will be verified using CMC controls and indicators. MSC Operation & Maintenance Manual, TDX Maintenance Manual, and the AIU Maintenance Manual troubleshooting procedures will be validated by injecting noncritical and critical (nondestructive) failures into the system and observing actual and expected results.

Data Collection and Analysis Method

Corrective maintenance procedures, as outlined in the TDX-2000d maintenance manual, will be performed during the test period to ensure that the TDX-2000d can detect and isolate faults. Selected system parameters will be changed to induce faults. Actual results will be compared with expected values and any errors will be identified. Troubleshooting and maintenance issues will be entered in the logbook.

Local and remote CMC error, warning, fault, and status messages will be logged to the hard disk. These files will be examined on a daily basis and any unexplained discrepancies will be investigated.

Corrective maintenance procedures, as outlined in the AIU maintenance manual, will be performed during the test period to ensure that the AIU can detect and isolate faults. Error messages logged to a file will be compared with actual AIU errors. These errors include; board failures, 'excessive' input message parity errors rate, number of successive missing sector marks, and overflow conditions (resulting in data loss). Also, the error log file will be examined to determine the source of the error. Input interface loop tests will be executed and any interruption of data or other anomalies will be documented.

6.1.17.4 Data Logging.

Purpose

Ensure that the CMCs and AIU provide a method to reliably store, retrieve, and analyze surveillance and status information.

Objectives

- a. Verify that the user can initiate and terminate data logging by following published instructions.
- b. Verify that the logging filter and the report filtering functions are suitable for collecting radar data.
- c. Verify that previously recorded data file can be played back through the system using the data playback function.
- d. Verify logging features of the AIU.

Description

The Select Options area contains the Replay and Log Options menu. Data Logging Control functions will be initiated to collect/log data. Each feature of data logging will be executed. A test log file will be recorded to the CMC hard disk. All data Playback Control Menu features will be exercised.

The AIU can capture and store to nonvolatile memory all incoming messages or a specified subset of message types. Data (including a mix of all message types) will be logged to the hard disk.

Data Collection and Analysis Method

A test scenario consisting of internally generated test targets will be logged to disk to validate CMC logging/playback features. Simultaneously, data will be recorded at the output with IRES RECORD program. The logged data file will be played back into the system and data will again be recorded at the output using IRES RECORD program. The files will be compared using SHOWPCS and COUNTPCS program. Differences in the original and playback data will be documented.

The same test scenario used to validate CMC logging features will be injected at the TDX-2000d and will be logged to the AIU disk to validate AIU logging features. Simultaneously, data will be recorded at the output of the TDX-2000d. The files will be compared and differences will be investigated.

6.2 SYSTEM OPERATIONAL TESTS.

6.2.1 Reliability, Maintainability, Availability.

Purpose

Ensure that the reliability, maintainability, and availability of the TDX-2000d system and AIU are suitable for incorporation into the NAS when used in an operational environment with the available resources, logistics plan, maintenance procedures, and personnel.

Objectives

- a. Verify that the TDX-2000d and AIU perform reliably during the test period.
- b. Identify any single points of failure in the TDX-2000d and AIU design.
- c. Verify the Mean-Time-To-Repair (MTTR) is not more than 0.5 hours and Mean-Time-To-Restore (MTR) is not more than 1.0 hour.

Description

Reliability will be assessed by documenting hardware and software failures in the logbook. Alarm and status information will be monitored throughout the test period.

TDX-2000d and AIU maintainability will be tested through verification of fault detection and isolation techniques and the ability of the operator to perform typical maintenance tasks. Site personnel will be asked to actively participate in all maintenance and repair actions. Problems associated with spares configuration and availability will be documented in the test logbook.

Data Collection and Analysis Method

Logbook entries and daily statistics that identify hardware and software reliability issues will be examined. Equipment failures will be analyzed to assess reliability.

The MTR and MTTR will be calculated by accurately timing a trained maintenance technician perform fault detection and isolation procedures and remove and replace operations. These tests will be logged in the test logbook and compiled at the completion of the test period.

Hardware and software fault data collected during testing will be examined. Any instances of failures that result in the loss or corruption of data will be investigated. Failures that affect the ability to control TDX and/or AIU operation will be investigated.

6.2.2 Site Adaptation and Optimization.

Purpose

Evaluate the ability to optimize the TDX-2000d and AIU to radar type and site specific conditions. Determine the ability of the TDX-2000d to adapt to environmental changes without frequent reoptimization.

Objective

Verify that the TDX-2000d and AIU design and procedures allow the radar system to be optimized and adapted to site conditions.

Description

ACT and AOS personnel will verify the ASR-8 baseline and validate Sensis checkout and optimization procedures. The optimization process for the TDX-2000d will be examined. Specific adjustments to the ASR-8 that are necessary for optimization will be documented in the logbook and included in the maintenance handbook where appropriate.

The test team will exercise ASR-8 modes of operation such as CP and LP, to determine the need for additional changes to TDX-2000d and AIU setup. Optimization procedures will be standardized where practical and incorporated into the setup and checkout documents.

Data Collection and Analysis Method

TDX-2000d and AIU performance will be monitored throughout system test. Any problems related to incorrect site optimization or adaptation will be documented.

Timing and video signals input to the TDX-2000d will be measured at specified times during the day (e.g. morning or evening). MSC daily statistics will be logged. Any ASR-8 changes in noise, offsets, or video levels will be documented and compared to any corresponding changes that may occur in daily statistics. Any problems will be logged in the test logbook and investigated.

The Reply Processor (REPRO) variable parameters will be validated including; start/stop processing ranges, timing trigger adjustments, offsets, and reply pulse tolerances.

The Plot Extractor (PLEX) variable parameters will be validated. These parameters are used primarily in the beacon detection and validation process. Also, the use and effectiveness of TDX Tools software will be analyzed. TDX Tools is a software program used to further optimize TDX-2000d performance off-line.

All Target Extractor (TEX) parameters will be verified including the methods used to establish the three independent range/azimuth variable maps; Threshold map, Clutter map, and the Range Varying Fixed Threshold map. Search Plot Extractor (SPLEX) parameters will be validated including the parameters associated with the plot extraction algorithm.

6.2.3 Human Factors.

Purpose

Evaluate user interfaces to ensure maintenance functions can be effectively performed.

Objective

Verify that the system equipment design conforms to human engineering design criteria and principles to achieve safe, reliable, and effective performance by operator and maintenance personnel.

Description

Routine maintenance and system control functions will be observed during the test period and the ease with which these functions can be performed will be evaluated. Any anomalies will be documented in the logbook at each test site. Site personnel and the test team will document maintenance handbook use and the effectiveness of training. This data will be compiled and used to identify deficiencies and areas of improvement.

7. ACRONYMS AND ABBREVIATIONS.

ACP	Azimuth Change Pulse
AF	Airway Facilities
AFB	Air Force Base
AGL	Above Ground Level
AIU	ARTS Interface Unit
ARP	Azimuth Reference Pulse
ARTS	Automated Radar Terminal System
ASD	Air Situation Display
ASR-8	Airport Surveillance Radar Model 8
ASR-9	Airport Surveillance Radar Model 9
ASR-11	Airport Surveillance Radar Model 11
AT	Air Traffic
ATC	Air Traffic Control
ATCBI-4	Air Traffic Control Beacon Interrogator Model 4
ATCRBS	Air Traffic Control Radar Beacon System
ATRAN	ARTS IIIA/TRACS Interface
BDAS	Beacon Data Acquisition System
BEXR	Beacon Extractor and Recorder
BIT	Built in Test
CD	Common Digitizer
CFAR	Constant False Alarm Rate

CMC	Control and Maintenance Console
COI	Critical Operational Issues
COTS	Commercial-Off-The-Shelf
CP	Circular Polarization
CSC	Critical System Characteristic
dB	decibel
FAA	Federal Aviation Administration
FRUIT	False Replies Unsynchronous In Time
GPS	Global Positioning System
ICD	Interface Control Document
IOP	Input/Output Processor
IRES	Integrated Radar Evaluation System
LP	Linear Polarization
LSSS	Laboratory Signal Switching System
MALA	Mode S/ASR-9 Line Adapter
Mode S	Mode Select Beacon System
MOE	Measure of Effectiveness
MOP	Measure of Performance
MSC	Multi-Scan Correlation
MTI	Moving Target Indicator
MTR	Mean Time To Restore
MTTR	Mean Time To Repair
NAS	National Airspace System

nm	nautical miles
OT&E	Operational Test and Evaluation
PC	Personal Computer
PLEX	Plot Extractor
PPI	Plan Position Indicator
PRT	Pulse Repetition Time
PT	Product Team
RADS	Radar Alphanumeric Display Subsystem
RBAT	Radar Beacon Analysis Tool
RCS	Radar Cross Section
RD	Requirements Document
RDAS	Radar Data Acquisition System
REPRO	Reply Processor
RF	Radio Frequency
RHI	Range Height Indicator
RMA	Reliability, Maintainability, Availability
RTQC	Real Time Quality Control
SDU	Signal Distribution Unit
SRAP	Sensor Receiver and Processor
SPI	Special Position Indicator
SPLEX	Search Plot Extractor
STARS	Standard Terminal Automation Replacement System
T&E	Test and Evaluation

TBD	To Be Determined
TDX	Target Data Extractor
TDX-2000d	Target Data Extractor Model 2000
TEX	Target Extractor
TQA	Track Quality Assessment
TRACON	Terminal Radar Approach Control
TRACS	Transportable Radar Analysis Computer System
UNIO	Universal Input/Output
UPS	Uninterruptable Power Supply
Video-BITS	Video Beacon Interrogator Test Set

APPENDIX A
TEST SCHEDULE

TDX-2000d TEST SCHEDULE

ID	Task Name	Start	Finish	February		March			April			May			June			July			August			September			October			November											
				1	8	15	22	1	8	15	22	5	12	19	26	3	10	17	24	31	7	14	21	28	5	12	19	26	2	9	16	23	30	6	13	20	27	4	11	18	25
27	Dobbins AFB Test Conduct	2/2/98	6/26/98	[Gantt bar from 2/2/98 to 6/26/98]																																					
28	Contractor Conducted Training	2/2/98	2/6/98	[Gantt bar from 2/2/98 to 2/6/98]																																					
29	Factory Acceptance Tests	2/16/98	2/16/98	[Gantt bar from 2/16/98 to 2/16/98]																																					
30	Site Survey	2/12/98	2/12/98	[Gantt bar from 2/12/98 to 2/12/98]																																					
31	Delivery to Dobbins AFB	2/16/98	2/16/98	[Gantt bar from 2/16/98 to 2/16/98]																																					
32	Contractor Integration and Checkout	2/19/98	3/6/98	[Gantt bar from 2/19/98 to 3/6/98]																																					
33	Sensis/ACT/AOS Optimization	3/9/98	4/13/98	[Gantt bar from 3/9/98 to 4/13/98]																																					
34	Integration Tests	5/27/98	6/26/98	[Gantt bar from 5/27/98 to 6/26/98]																																					
35	System Coverage	5/27/98	6/2/98	[Gantt bar from 5/27/98 to 6/2/98]																																					
36	Primary Target Detection	5/27/98	6/23/98	[Gantt bar from 5/27/98 to 6/23/98]																																					
37	Primary False Alarm Rate	6/22/98	6/25/98	[Gantt bar from 6/22/98 to 6/25/98]																																					
38	Weather Detection and Processing	5/27/98	6/26/98	[Gantt bar from 5/27/98 to 6/26/98]																																					
39	Beacon Target Detection	5/27/98	6/23/98	[Gantt bar from 5/27/98 to 6/23/98]																																					
40	Beacon Spills and False Report Rate	6/15/98	6/18/98	[Gantt bar from 6/15/98 to 6/18/98]																																					
41	Operational Tests at Dobbins	2/16/98	6/26/98	[Gantt bar from 2/16/98 to 6/26/98]																																					
42	RMA	2/16/98	6/26/98	[Gantt bar from 2/16/98 to 6/26/98]																																					
43	Human Factors	2/16/98	6/26/98	[Gantt bar from 2/16/98 to 6/26/98]																																					
44	Site Adaptation & Optimization	2/16/98	3/17/98	[Gantt bar from 2/16/98 to 3/17/98]																																					
45	Quick Look Report	7/15/98	7/15/98	[Gantt bar from 7/15/98 to 7/15/98]																																					
46	Final Report	9/23/98	9/23/98	[Gantt bar from 9/23/98 to 9/23/98]																																					

APPENDIX B
SUMMARY OF RESOURCES

Table 1 summarizes the resources needed for the Digitizer Test. The resources not listed are; TDX-2000d, AIU, and contractor engineering support.

Resource	Tests Requiring Resources *														
	1	2	3	4	5	6	7	8	9	10	11	12	13	14	15
Dobbins AN/GPN-20, ATCBI-4		X	X	X	X			X	X				X	X	X
Technical Center ASR-8, AN/UPX-27	X	X	X	X	X	X	X	X	X	X	X	X	X	X	X
ASR-9, NEXRAD								X							
Communications Radio			X	X		X	X								
Dobbins Site Technician (1)		X	X	X	X				X				X	X	X
Small RCS Aircraft with Pilot			X	X											
Two GPS Equipped Aircraft						X	X								
GPS Base Station						X	X								
Automation Facilities (ARTS IIA, STARS, RADSS)	X	X	X	X	X	X	X	X				X		X	
Test Sets	X			X											
Digital Recorders (IRES and A-Train)	X	X	X	X	X	X	X	X	X	X	X	X	X	X	X

TABLE 1. SUMMARY OF RESOURCES

- *Test:
- 1 Interface & Data Format Verification
 - 2 System Coverage
 - 3 Primary Target Detection
 - 4 Beacon Target Detection
 - 5 Primary False Alarm Rate
 - 6 Radar and Beacon Range and Azimuth Resolution
 - 7 Positional Accuracy
 - 8 Weather Detection and Processing
 - 9 Beacon Splits & False Reports
 - 10 Beacon Code Validation & Accuracy
 - 11 Capacity and Delay
 - 12 System Control Operation
 - 13 Reliability, Maintainability/Availability
 - 14 Site Adaptation & Optimization
 - 15 Human Factors

AN/GPN-20, ATCBI-4
System time on the AN/GPN-20 must be coordinated and scheduled through the TRACON facility at Atlanta.

Technical Center ASR-8, AN/UPX-27
System time on the ASR-8 must be scheduled through the Facility Control Office (FACO) at the Technical Center.

ASR-9, NEXRAD
Time on the ASR-9 must be scheduled through FACO at the Technical Center.

Communications Radio
Ground based radio communication is available at the Technical Center.

Dobbins Site Technician
Technicians are available for AN/GPN-20 support at Atlanta. Support for system tests must be coordinated through a program office representative and the southern region.

Small RCS Aircraft with Pilot
The small RCS aircraft needed for detection flight tests will be rented in the Atlanta area.

Two GPS Equipped Aircraft
The aircraft, pilots, and GPS equipment are available for the test. Scheduling of these resources is required through FACO.

Facilities (ARTS IIA, STARS, RADSS)
System time on the automation equipment must be scheduled through FACO at the Technical Center prior to commencement of system test. The automation equipment at the Technical Center are used in many different field support and test activities. Therefore, daytime hours may not always be available for the testing due to conflicts with other users.

Test Sets
ATCBI-5 beacon test set, Sensis BEXR and Video-BITS test sets are available at the Technical Center.

Digital Recorders
IRES and A-Train data recorders are available at the Technical Center.