

REPORT DOCUMENTATION PAGE

AFRL-SR-BL-TR-98-

0355

3
Data sources,
inspect of this
15 Jefferson

Public reporting burden for this collection of information is estimated to average 1 hour per response gathering and maintaining the data needed, and completing and reviewing the collection of information, including suggestions for reducing this burden, to Washington Headquarters, Suite 1204, Arlington, VA 22202-4302, and to the Office of Management and Budget,

1. AGENCY USE ONLY (Leave blank)		2. REPORT DATE		3. REPORT TYPE AND DATES COVERED	
				Final 3/1/95-2/28/98	
4. TITLE AND SUBTITLE				5. FUNDING NUMBERS	
Nonlinear Control Systems				G-F49620-95-1-0232	
6. AUTHOR(S)					
Christopher I. Byrnes Alberto Isidori					
7. PERFORMING ORGANIZATION NAME(S) AND ADDRESS(ES)				8. PERFORMING ORGANIZATION REPORT NUMBER	
Washington University Dept. of Systems Science and Mathematics Campus Box 1040, One Brookings Drive St. Louis, MO 63130				59114	
9. SPONSORING / MONITORING AGENCY NAME(S) AND ADDRESS(ES)				10. SPONSORING / MONITORING AGENCY REPORT NUMBER	
AFOSR/NM 110 Duncan Ave., Suite B115 Building 410 Bolling AFB, DC 20332-0001					
11. SUPPLEMENTARY NOTES					
12a. DISTRIBUTION / AVAILABILITY STATEMENT				DISTRIBUTION CODE	
Unclassified/Unlimited				19980430 076	
13. ABSTRACT (Maximum 200 words)					
<p>The principal goal of this three-year research effort was to enhance the research base which would support efforts to systematically control, or take advantage of, dominant nonlinear or distributed parameter effects in the evolution of complex dynamical systems. Such an enhancement is intended to support the development of flight controllers for increasing the high angle of attack or high agility capabilities of existing and future generations of aircraft and missiles.</p> <p>The principal investigating team has succeeded in the development of a systematic methodology for designing feedback control laws solving the problems of asymptotic tracking and disturbance rejection for nonlinear systems with unknown, or uncertain, real parameters.</p> <p>Another successful research project was the development of a systematic feedback design theory for solving the problems of asymptotic tracking and disturbance rejection for linear distributed parameter systems. The technical details which needed to be overcome are discussed more fully in this final report.</p>					
14. SUBJECT TERMS				15. NUMBER OF PAGES	
nonlinear controller design, output regulation, asymptotic tracking, robust nonlinear control, stabilization and control of distributed parameter systems.				66	
				16. PRICE CODE	
17. SECURITY CLASSIFICATION OF REPORT		18. SECURITY CLASSIFICATION OF THIS PAGE		19. SECURITY CLASSIFICATION OF ABSTRACT	
20. LIMITATION OF ABSTRACT					

AFOSR FINAL REPORT

March 1, 1995 – February 28, 1998

NONLINEAR CONTROL SYSTEMS

AFOSR Grant No. – F49620 - 95 - 1 - 0232

PI: Christopher I. Byrnes and Alberto Isidori

Department of Systems Science and Mathematics
Washington University
Campus Box 1163
One Brookings Drive St. Louis, MO 63130

1 Executive Summary

The principal goal of this three-year research effort was to enhance the research base which would support efforts to systematically control, or take advantage of, dominant nonlinear or distributed parameter effects in the evolution of complex dynamical systems. Such an enhancement is intended to support the development of flight controllers for increasing the high angle of attack or high agility capabilities of existing and future generations of aircraft and missiles.

The principal investigating team has succeeded in the development of a systematic methodology for designing feedback control laws solving the problems of asymptotic tracking and disturbance rejection for nonlinear systems with unknown, or uncertain, real parameters. The main technical issue which was overcome was the lack of a traditional observer - or state estimator - design for uncertain systems, caused by the fact that traditional observations cannot detect the values of the unknown real parametric uncertainties. This limitation was overcome by the development of a new design methodology which is based on the concept of immersing one system into another, a topic which is discussed more fully in this report and in a recent book by the principal investigating team. The idea developed was, intuitively, based on an attempt to propagate just the information needed in a feedback law rather than the entire state and parameter values. When applied to the Kalman filter, this observation also led to the solution of a fundamental problem in stochastic systems theory, with applications to speech synthesis and voice recognition. A patent application for a related invention is pending.

Another successful research project was the development of a systematic feedback design theory for solving the problems of asymptotic tracking and disturbance rejection for linear distributed parameter systems. The technical details which needed to be overcome are discussed more fully in this final report.

1.1 Robust Nonlinear Control

As a starting point, we recall that one of the classical problems which involves shaping the response of a system is output regulation, in which the objective is that of controlling a plant in order to have its output track (or reject) exogenous commands or disturbances. The nonlinear regulator theory developed in [12] is valid in case a model for an "exosystem" which generates the exogenous signal to be tracked and the exogenous disturbance to be rejected is known and satisfies certain conditions. These conditions currently prohibit the incorporation of certain signal generators which also have application, such as tracking a ramp or a limit cycle.

For lumped linear systems, the task of developing a robust regulator theory involves more challenging cases when either:

a signal generator, or reference model, is known but certain parameters in the system or in the disturbance channel are unknown (*structured uncertainty*); or

a signal generator for disturbances is not known (*unstructured uncertainty*)

Both of these problems are central focal points in the modern approach to robust control.

Setting some notation we consider the problem of output regulation for nonlinear systems modeled by equations of the form

$$\begin{aligned}\dot{x} &= f(x, u, w) \\ e &= h(x, w),\end{aligned}\tag{1.1}$$

with state $x \in X \subset \mathbb{R}^n$, control input $u \in \mathbb{R}^m$, regulated output $e \in \mathbb{R}^m$ and exogenous disturbance input $w \in W \subset \mathbb{R}^r$ generated by an exosystem

$$\dot{w} = s(w).\tag{1.2}$$

We assume that $f(x, u, w)$, $h(x, w)$ and $s(w)$ are C^k functions (for some large k) of their arguments and also that $f(0, 0, 0) = 0$, $h(0, 0) = 0$ and $s(0) = 0$.

Generally speaking, a problem of *local* output regulation is to design a feedback controller so as to obtain a closed loop system in which, when $w(t) = 0$, a certain equilibrium is locally asymptotically stable and, when $w(t) \neq 0$ and sufficiently small, the regulated output $e(t)$ asymptotically decays to 0 as $t \rightarrow \infty$. The structure of the controller usually depends on the amount of information available for feedback. We have primarily focused our attention on the case in which the information in question only consists, at each time t , in the value $e(t)$ of the error at this time. In other words, we consider controllers modeled by equations of the form

$$\begin{aligned}\dot{\xi} &= \eta(\xi, e) \\ u &= \theta(\xi)\end{aligned}\tag{1.3}$$

with state $\xi \in \Xi^\circ \subset \mathbb{R}^\nu$, in which $\eta(\xi, e)$ and $\theta(\xi)$ are C^k functions of their arguments, and $\eta(0, 0) = 0$, $\theta(0) = 0$. The purpose of output regulation is to obtain a closed loop system in which, from every initial condition in a neighborhood of the equilibrium $(x, \xi, w) = (0, 0, 0)$, the response of the regulated output asymptotically converges to 0 as time tends to ∞ .

It is important to observe that output regulation entails the problems of the asymptotic tracking of a class of reference trajectories, the disturbance attenuation of a class of disturbances, and the requirement that both attenuation and tracking be achieved while maintaining internal stability of the closed-loop system. In this regard, one may think of the exosystem as consisting of two subsystems, one which generates signals to be tracked, and one which generates the disturbances to be attenuated.

The case when the exosystem is a harmonic oscillator is, of course, classical. Even in this special case, the difference between state and error measurement feedback in the problem of output regulation is profound. To know the initial condition of the exosystem is to know the amplitude and phase of the corresponding sinusoid. On the other hand, to solve the output regulation problem in this case with only error measurement feedback is to track, or attenuate, a sinusoid of known frequency but with unknown amplitude and phase. This is in sharp contrast with alternative approaches, such as exact output tracking, where in lieu of the assumption that a signal is within a class of signals generated by an exogenous system, one instead assumes complete knowledge of the past, present and future time history of the trajectory to be tracked.

In this setup, the problem in question can be formally posed in the following terms.

Local Output Regulation. Given a nonlinear system of the form (1.1) with exosystem (1.2) find, if possible, a controller of the form (1.3) such that:

(a) the equilibrium $(x, \xi) = (0, 0)$ of the unforced closed loop system

$$\begin{aligned}\dot{x} &= f(x, \theta(\xi), 0) \\ \dot{\xi} &= \eta(\xi, h(x, 0))\end{aligned}\tag{1.4}$$

is locally asymptotically stable in the first approximation,

(b) the forced closed loop system

$$\begin{aligned}\dot{x} &= f(x, \theta(\xi), w) \\ \dot{\xi} &= \eta(\xi, h(x, w)) \\ \dot{w} &= s(w)\end{aligned}\tag{1.5}$$

is such that

$$\lim_{t \rightarrow \infty} e(t) = 0$$

for each initial condition $(x(0), \xi(0), w(0))$ in a neighborhood of the equilibrium $(0, 0, 0)$. \triangleleft

The importance of asymptotic tracking, disturbance attenuation, and internal stability in their own right underscores the central role which the problem of output regulation has played in the development of classical and modern automatic control.

Consider, for example, the problem of asymptotic output regulation for which we observe that we must also be able to:

- i. design locally exponentially stabilizing state feedback laws for nonlinear control systems,

- ii. determine conditions for the existence of (stable) forced oscillations, in the special case when the exosystem is a harmonic oscillator,
- iii. design state feedback laws which shape the steady state response to harmonic forcing for general classes of exosystems, as well as for harmonic oscillators,
- iv. design dynamic filters, or compensators, which produce a proxy for the system-exosystem state for feedback laws achieving the prior objectives.

These are the basic ingredients to both the output regulation problem. The key features of these basic ingredients are outlined as follows:

Exponential Stabilization. This first basic ingredient is indeed a problem concerning the linear approximation

$$\dot{x} = Ax + Bu$$

of the nonlinear control system

$$\dot{x} = f(x, u, 0)$$

at the equilibrium $(x, u, w) = (0, 0, 0)$. In this case, if all systems parameters are known, problem (i) can be solved by any of a number of standard approaches, such as infinite horizon, linear-quadratic optimal control or infinite horizon H_∞ control design. Moreover, our calculations have shown that the general solution with error measurement feedback very easily incorporates any given solution to problem (i) into a general law achieving local output regulation. The same calculations extend to the case where certain plant parameters, denoted by μ , are unknown. In this case, one considers the linear approximation

$$\dot{x} = A_\mu x + B_\mu u \tag{1.6}$$

of a nonlinear control system

$$\dot{x} = f_\mu(x, u, 0).$$

The problem of determining the stability for arbitrary families of n -dimensional systems with m -dimensional inputs has been shown to be NP-hard. The problem of stabilizing the linearization (1.6), for all parametric uncertainties within the class of n -dimensional systems with m -dimensional inputs, with a linear controller is sometimes suspected of being to be NP-hard as well. On the other hand, if one admits nonlinear controllers and insists that the pair (A_μ, B_μ) be controllable for every μ , then adaptive stabilization schemes are known, underscoring the potential usefulness of nonlinear output regulation, even in a linear context.

Forced Oscillations and the Existence of a Steady-State Response. For constant coefficient, linear control systems

$$\dot{x} = Ax + Dw, \quad w(t) = U \sin(\omega t)$$

where no eigenvalue of A lies on the imaginary axis, problem (ii) has a complete and satisfying resolution. Viewing ω as fixed by the choice of the harmonic oscillator with frequency ω as

the exosystem, for each amplitude U there is exactly one initial condition x° which generates a periodic trajectory with period $T = 2\pi/\omega$. Moreover, the periodic orbit is asymptotically stable if, and only if, the unforced system is, i.e. whenever the eigenvalues of A all lie in the open left half plane, which we can assume has been arranged as in problem (i).

For nonlinear control systems

$$\dot{x} = f(x, 0, w) \quad (1.7)$$

where, for example, $w(t) = U \sin(\omega t)$, the situation is far more complex, with the possibility of one, or several, forced oscillations with varying stability characteristics occurring. In addition, the fundamental harmonic of these periodic responses may agree with the frequency of the forcing term (harmonic oscillations), or with integer multiples or divisors of the forcing frequency (higher harmonic, or subharmonic, oscillations). Despite a vast literature on nonlinear oscillations, a subject with its origins in celestial mechanics, only for second order systems is there much known about the stability of forced oscillation and, in particular, which of these three kinds of periodic responses might be asymptotically stable.

It is interesting, then, to view the solution of the problem of output regulation for local and more global problems in this context. We shall limit ourselves to a discussion about the local case. Suppose, for simplicity of discussion, that (1.7) is affine in w , i.e., so that we have

$$\dot{x} = f_0(x) + p(x)w ,$$

or, in particular,

$$\dot{x} = f_0(x) + p(x)U \sin(\omega t)$$

and we can view $p(x)U \sin(\omega t)$ as a small perturbation. This is the basis of the method of averaging for determining the existence and stability of periodic orbits. A similar analysis is motivation for the method of "harmonic balance" in which a Fourier series is considered for an assumed periodic trajectory of period $T = 2\pi/\omega$ and the Fourier coefficients are determined so that the differential equation is satisfied; i.e., so that

$$\int_0^T f(x(s), 0, U \sin(\omega s)) ds = 0 . \quad (1.8)$$

Averaging and harmonic balance have their origin in the method of "small parameters," pioneered by Poincaré. Briefly, in the case of constant coefficients linear control systems, the initial condition x° which generates a periodic trajectory can be expressed as a linear function of the amplitude U

$$x^\circ = PU$$

using the variation of parameters formula, so that

$$P = (I - e^{AT})^{-1} \int_0^T e^{A(T-s)} D \sin(\omega s) ds .$$

Poincarè's idea was to take the linear function obtained for the first approximation as the first term in a power series representation in U ,

$$x^\circ = PU + P_2U^2 + P_3U^3 + \dots$$

which can in principle be developed from (1.8) for an assumed periodic trajectory of period T or, alternatively, for an initial condition which generates this trajectory. Of course, one needs to check that the series converges and represents a function $\pi(U)$ in a neighborhood of $U = 0$. Our approach is geometric and seeks instead to "sum the series"

$$x^\circ = PU + P_2U^2 + P_3U^3 + \dots = \pi(U)$$

by characterizing $\pi(U)$ as the solution of a system of partial differential equations, for which the center manifold theorem guarantees existence of a solution. More explicitly, observe that in general the response of system (1.7), in the initial state $x(0) = x_0$ and subject to the input $U \sin(\omega t)$, coincides with the response of the autonomous system

$$\begin{aligned} \dot{x} &= f(x, 0, w) \\ \dot{w} &= Sw \end{aligned} \tag{1.9}$$

where $w \in \mathbb{R}^2$,

$$S = \begin{bmatrix} 0 & \omega \\ -\omega & 0 \end{bmatrix}, \quad d(w) = w_1,$$

and

$$x(0) = x_0, \quad w(0) = w_0 = \begin{bmatrix} 0 \\ U \end{bmatrix}.$$

Assuming that we have solved, and implemented, the feedback stabilization problem, the *center manifold* can be expressed as the graph of a mapping $x = \pi(w)$, where $\pi(w)$ is a C^{k-1} function satisfying

$$\frac{\partial \pi}{\partial w} Sw = f(\pi(w), d(w))$$

and $\pi(0) = 0$.

The restriction of the flow of (1.9) to its center manifold is indeed a copy of the flow of

$$\dot{w} = Sw.$$

As a consequence, if U is sufficiently small and $x_0 = \pi(w_0)$, the response $x(t)$ exists for all $t \in \mathbb{R}$ and is periodic of period T . Moreover, once one has implemented a solution to problem (i), asymptotic (orbital) stability of the steady-state response also follows from the center manifold theorem. Furthermore, for the problem of output regulation treated in our work, the center manifold can be shown to be unique.

For a nonlinear control system with unknown parameters

$$\dot{x} = f_{\mu}(x, u, 0)$$

these arguments persist, yielding an asymptotically stable, steady-state response which, of course, is dependent on μ , and hence unknown for purposes of problem (iii).

Shaping the Steady-State Response. The third basic ingredient in output regulation, the ability to shape the steady-state response of a nonlinear control system

$$\dot{x} = f(x, u, w)$$

is prescriptive in nature, and would appear to be quite challenging from the point of view of the more descriptive tools for predicting the existence of a steady-state response. In our approach to classical and robust output regulation, the existence of a steady-state response and the ability to shape this response are embodied in each of two equations, known as the “regulator equations,”

$$\begin{aligned} \frac{\partial \pi}{\partial w} s(w) &= f(\pi(w), c(w), w) \\ 0 &= h(\pi(w), w) \end{aligned} \tag{1.10}$$

for two C^k (with $k \geq 1$) mappings $\pi : W_0 \rightarrow \mathbb{R}^n$ and $c : W_0 \rightarrow \mathbb{R}^m$ (where $W_0 \subset W$ is a neighborhood of $w = 0$), with $\pi(0) = 0$ and $c(0) = 0$, and whose solution necessarily exists if the problem of local output regulation can be solved using any method.

While the first of the regulator equations will always have a solution, as a consequence of the center manifold theorem, the solvability of the system of regulator equations can be expressed in a system theoretic framework which has an appealing “frequency domain” interpretation. In classical automatic control, there is a simple, intuitive condition for solvability of the problem of output regulation: no transmission zero of the plant to be controlled should coincide with a natural frequency of the signal to be tracked (or attenuated). For, while a unique steady-state periodic response to harmonic forcing at such a frequency certainly exists for a linear, single-input single-output transfer function, if the emitted response is absorbed at this frequency we cannot adjust its amplitude or phase by feedback.

This fundamental condition can be recast in a state-space form by introducing a linear operator whose spectrum on one subspace coincides with the plant transmission zeros and on whose spectrum on another subspace coincides with the natural frequencies of the exosystem. In this setting, to say that no transmission zero of the plant coincides with a natural frequency of the signals to be tracked is to say that these two subspaces are complementary. We can also describe an existence theory for the regulator equations which provides a nonlinear enhancement of this criterion, in terms of zero dynamics. Briefly, since whenever $w = 0$ and the system output $h(x, 0)$ is constrained to be zero we must have that the error is zero, the zero dynamics of the augmented system contains the zero dynamics of the system to be controlled. In this setting, the regulator equations are solvable just in case the plant zero dynamics are complemented in the augmented zero dynamics by a copy of the exosystem.

Filtering a Proxy for the Plant/Exosystem State. If the plant/exo-system is exponentially detectable using the error variables as an output measurement, one can verify that a “separation principle” holds for output regulation via state feedback and a standard state observer scheme.¹ Unlike exponential stabilizability of the plant, however, detectability of the augmented system is not a necessary condition for the solvability of the problem of output regulation. More importantly, detectability of the augmented system will not hold when we treat the case of robustness with respect to real, parametric uncertainty. Rather, the derivation of the regulator equations for the error measurement case reveals that the actual necessary condition relating to measurements of the augmented state is, in fact, a geometric formulation of the “internal model principle.” In short, rather than it being necessary to be able to recover the augmented state, it is only necessary that any dynamic compensator which achieves output regulation must also contain a copy of the exosystem.

With these motivations in mind, we now combine the actual necessary conditions, embodied in the regulator equations, with the notion of “immersion” of a nonlinear system to derive a new class of systems which generalize dynamic observers and provide a “proxy” for the state in a compensator design which provides an alternative to the design based on a separation principle.

Consider the problem of designing feedback laws achieving output regulation for periodic signals with an unknown frequency. For simplicity, we first consider a one-dimensional scalar linear control system.

For a linear plant:

$$\begin{aligned} \dot{x} &= u \\ y &= h(x) = x \end{aligned}$$

and an exogenous system defined by the harmonic oscillator $\dot{w} = s(w)$

$$\begin{aligned} s\dot{w}_1 &= w_2 \\ \dot{w}_2 &= -\mu^2 w_1 \\ \dot{\mu} &= 0 \\ \pi(w) &= w_1 \end{aligned}$$

with an unknown by fixed frequency. We first note that the harmonic oscillator is now represented by a (critical) nonlinear system. We wish to design a (possibly nonlinear) feedback system so that the plant state x tracks $\pi(w)$ for a continuous range $\mu \in [.5, 4]$. In this case, we define the tracking error to be $e = x - \pi(w)$ and proceed to formulate and solve the regulator equations, which of course are quite simple in this case.

The second regulator equation implies

$$x = \pi(w) = w_1$$

which, when differentiated yields the first regulator equation and an explicit expression for the zero error input, $u = c(w)$.

¹See [12].

$$\dot{x} = \frac{\partial \pi(w)}{\partial w} s(w) = w_2,$$

$$c(w) = w_2 \{ \text{zero error input} \}$$

Now define a feedback law

$$u = c(w) + k(x - w_1)$$

where k is chosen to stabilize the plant in the first approximation when $\pi(w) = 0$. The closed loop system is therefore given by

$$\begin{aligned} \dot{x} &= w_2 + k(x - w_1) \\ \dot{w}_1 &= w_2 \\ \dot{w}_2 &= -\mu^2 w_1 \\ \dot{\mu} &= 0 \\ e &= x - w_1 \end{aligned}$$

leading to the following performance.

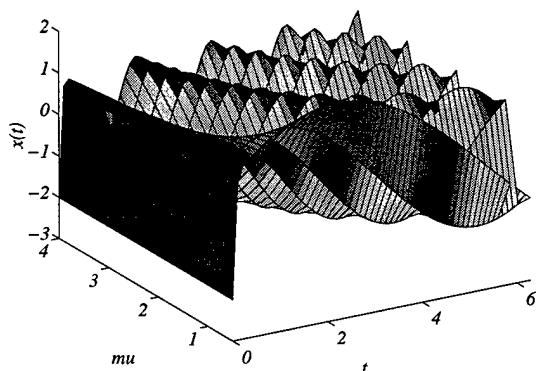

Figure 2.2.1

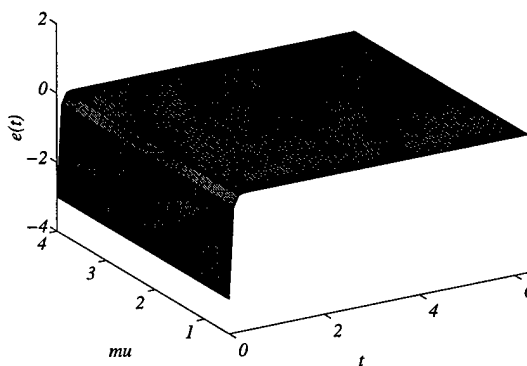

Figure 2.2.2

We note, however, that although the feedback scheme does not explicitly contain the unknown parameter μ it does contain the exosystem state variable w_2 which is not observable from the error without explicit knowledge of μ . Actually, we need only produce the desired feedback law asymptotically, not exactly at each instant of time, in order to solve this robust output regulation problem. That is, in lieu of an observer based design, we need only design a dynamical system which asymptotically produces the error zeroing control.

Next we illustrate this design philosophy for a periodic motion with unknown frequency and phase but with known amplitude; i.e., we assume that the norm of the initial condition $w(0)$ is known and, for simplicity is equal to 1.

In fact, robust tracking problem is intimately related to a problem of output regulation for a four-dimensional nonlinear oscillator which produces oscillations at every frequency. In

fact, this system was designed to asymptotically produce the control law designed above. More explicitly, consider the harmonic oscillator in its more typical representation

$$\begin{aligned}\dot{w}_1 &= \mu w_2 \\ \dot{w}_2 &= -\mu w_1 \\ \dot{\mu} &= 0 \\ \pi(w) &= w_1\end{aligned}$$

Suppose one now defines $\xi_1 = w_1$ and begins differentiating m times until $\dot{\xi}_m = \eta(\xi_1, \xi_2, \dots, \xi_{m-1})$. One then has a closed system whose linear approximation is observable and whose first state $\xi_1 = w_1$ for the "right" initial conditions.

$$\begin{aligned}\dot{\xi}_1 &= \dot{w}_1 = \mu w_2 = \xi_2 \\ \dot{\xi}_2 &= -\mu^2 w_1 = \xi_3 \\ \dot{\xi}_3 &= -\mu^3 w_2 = \xi_4 \\ \dot{\xi}_4 &= \mu^4 w_1 = \xi_5\end{aligned}$$

If the restriction $w_1^2 + w_2^2 = 1$ is imposed, then

$$\dot{\xi}_4 = \mu^4 w_1 = \mu^4 w_1 (w_1^2 + w_2^2)$$

which can be written as

$$\dot{\xi}_4 = \xi_1 \xi_3^2 - \xi_2^2 \xi_3.$$

Now if $w_1(0) = a_1$ and $w_2(0) = a_2$ then the four-dimensional nonlinear system simulates the two-dimensional system for the "right" conditions stated below.

$$\left\{ \begin{array}{l} \dot{\xi}_1 = \xi_2 \\ \dot{\xi}_2 = \xi_3 \\ \dot{\xi}_3 = \xi_4 \\ \dot{\xi}_4 = \xi_1 \\ \pi(\xi) = \xi_1 = w_1 \end{array} \right\} \quad \text{subject to} \quad \left\{ \begin{array}{l} \xi_1(0) = a_1 \\ \xi_2(0) = \mu a_2 \\ \xi_3(0) = -\mu^2 a_1 \\ \xi_4(0) = -\mu^3 a_2 \\ a_1^2 + a_2^2 = 1 \end{array} \right\}.$$

Furthermore, this same four-dimensional nonlinear system oscillates at a frequency which is determined by its initial conditions. Finally, we note that this system, with the first coordinate as the system output, is in fact observable. In particular, one can recover functionals of the state, such as the second coordinate, and so the nonlinear oscillator can be used as a proxy for the feedback law designed for the harmonic oscillator having arbitrary frequency.

Briefly, the second regulator equation yields $\pi(\xi) = \xi_1$ which, when differentiated, yields the first regulator equation and an explicit expression for the zero error input, $u = c(\xi)$

$$\dot{x} = \frac{\partial \pi(\xi)}{\partial \xi} s(\xi) = \xi_2$$

$$c(\xi) = \xi_2 \text{ \{zero error input\}}.$$

Now define a feedback law

$$u = c(\xi) + k(x - \xi_1)$$

where the scalar k is chosen to stabilize the one-dimensional plant. The closed loop system is therefore given by

$$\begin{aligned} \dot{x} &= \xi_2 + k(x - \xi_1) \\ \dot{\xi}_1 &= \xi_2 \\ \dot{\xi}_2 &= \xi_3 \\ \dot{\xi}_3 &= \xi_4 \\ \dot{\xi}_4 &= \xi_1 \xi_3^2 - \xi_2^2 \xi_3 \\ e &= x - \xi_1 \end{aligned}$$

Notice that in reality the task has not yet been truly completed because the state ξ_2 is not actually available for measurement. However, for a neutrally stable system having a detectable linear approximation, there exists a local exponential observer [1]. Recall the nonlinear exosystem with output $\gamma(\xi)$

$$\begin{aligned} \dot{\xi}_1 &= \xi_2 \\ \dot{\xi}_2 &= \xi_3 \\ \dot{\xi}_3 &= \xi_4 \\ \dot{\xi}_4 &= \xi_1 \xi_3^2 - \xi_2^2 \xi_3 \\ \gamma(\xi) &= \xi_1 \end{aligned}$$

The linear approximation is shown below

$$A = \begin{bmatrix} 0 & 1 & 0 & 0 \\ 0 & 0 & 1 & 0 \\ 0 & 0 & 0 & 1 \\ 0 & 0 & 0 & 0 \end{bmatrix}, \quad C = [1 \ 0 \ 0 \ 0].$$

It is not difficult to show that

$$\begin{bmatrix} C \\ CA \\ CA^2 \\ CA^3 \end{bmatrix}$$

has full rank. In accordance with [1], let $e_0 = z_1 - \xi_1$ be the error between the first observer state and the only available state from the exosystem and seek L such that $A - LC$ is Hurwitz. One such choice is

$$L = \begin{bmatrix} 10 \\ 35 \\ 50 \\ 24 \end{bmatrix}.$$

The resulting nonlinear observer is

$$\dot{z} = \begin{bmatrix} 0 & 1 & 0 & 0 \\ 0 & 0 & 1 & 0 \\ 0 & 0 & 0 & 1 \\ 0 & 0 & 0 & 0 \end{bmatrix} z + \begin{bmatrix} 10 \\ 35 \\ 50 \\ 24 \end{bmatrix} e_0 + \begin{bmatrix} 0 \\ 0 \\ 0 \\ z_1 z_3^2 - z_2^2 z_3 \end{bmatrix}.$$

Thus, the state z_2 estimates the inaccessible state ξ_2 in the feedback loop.

We now depict the plots of the tracking state x_1 and the tracking error $e = x - \xi_1$ along with the observed feedback state z_2 and the observing error $e_2 = z_2 - \xi_2$ are shown.

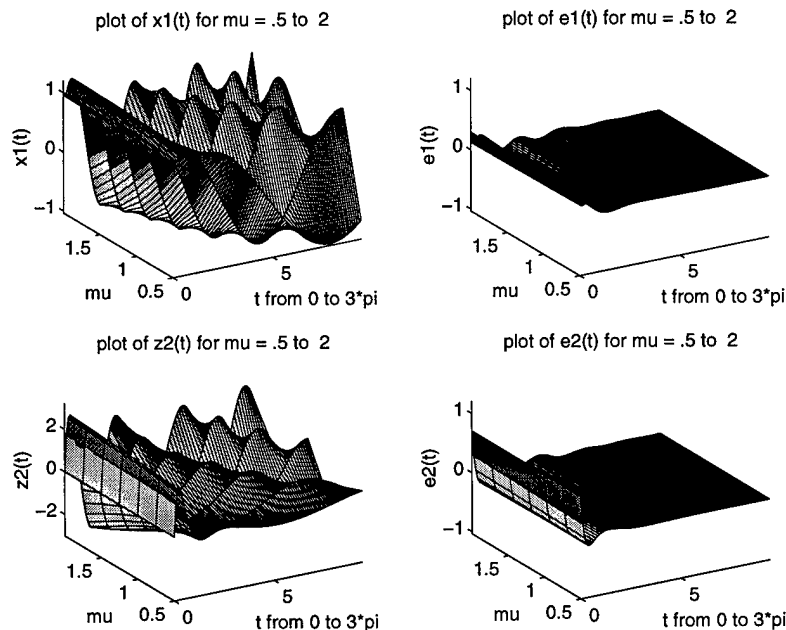

Figure 2.2.3

We shall now describe, in a more formal and complete manner, the concepts, constructions, and basic theory underlying the use of “asymptotic proxies” in feedback design for unobservable, or nondetectable, systems and its role in robust control. As it turns out, a key construction to understanding this technique is the formulation of the problem of system immersion, pioneered by M. Fliess. As already we have already observed, the first one of the regulator equations (1.10) expresses the property that the graph of the mapping $x = \pi(w)$ is an *invariant manifold* for the composite system

$$\begin{aligned} \dot{x} &= f(x, c(w), w) \\ \dot{w} &= s(w) \end{aligned} \tag{1.11}$$

while the second equation expresses the property that the error map $e = h(x, w)$ is zero at each point of this invariant manifold. In slightly different (and indeed equivalent) terms, one may say that the regulator equations call for the existence of a map $u = c(w)$ with

the property that the composite system (1.11), namely the controlled plant driven by the autonomous subsystem

$$\begin{aligned}\dot{w} &= s(w) \\ u &= c(w)\end{aligned}\tag{1.12}$$

has an invariant manifold on which the error map is zero.

The existence of such an invariant manifold, however, is not the only condition that system (1.11) is required to satisfy. In fact, by extending the analysis presented in [12], it is possible to identify additional necessary conditions (which are very similar to those established earlier in [1], [2]) for the solvability of a problem of output regulation. These additional conditions can be expressed as properties of the autonomous subsystem (1.12) and, together with those expressed in (1.10), can be used to provide a complete set of necessary and sufficient for the solvability of the problem under investigation.

The formulation of these new conditions is based on the notion of *immersion* of a given system into another one, which is defined as follows. Let $\{X, f, h\}$ denote the autonomous system

$$\begin{aligned}\dot{x} &= f(x) \\ y &= h(x),\end{aligned}\tag{1.13}$$

with state $x \in X$ and output $y \in \mathfrak{R}^m$, in which we suppose f to be a C^k vector field and h a C^k mapping, for some sufficiently large k , with $f(0) = 0$ and $h(0) = 0$.

Definition 1.1. (see [3], [4]). System $\{X, f, h\}$ is immersed into system $\{X', f', h'\}$ if there exists a C^k mapping $\tau : X \rightarrow X'$, satisfying $\tau(0) = 0$ and

$$h(x) \neq h(z) \Rightarrow h'(\tau(x)) \neq h'(\tau(z)),$$

such that

$$\begin{aligned}\frac{\partial \tau}{\partial x} f(x) &= f'(\tau(x)) \\ h(x) &= h'(\tau(x))\end{aligned}$$

for all $x \in X$.

Note that, if $\{X, f, h\}$ is immersed into $\{X', f', h'\}$, any output response of $\{X, f, h\}$ (i.e. the response from any arbitrary initial state $x_0 \in X$) is also an output response of $\{X', f', h'\}$ (namely, the response from the initial state $\tau(x_0) \in X'$).

For example the system

$$\begin{aligned}\dot{w}_1 &= \mu w_2 \\ \dot{w}_2 &= -\mu w_1 \\ \dot{\mu} &= 0\end{aligned}$$

evolving on the state manifolds

$$\left\{ (w_1, w_2, \mu) : w_1^2 + w_2^2 = 1 \right\} \subset \mathbb{R}^3$$

can be immersed into the 4-dimensional nonlinear oscillator via the mapping

$$\begin{bmatrix} \xi_1 \\ \xi_2 \\ \xi_3 \\ \xi_4 \end{bmatrix} = \tau \begin{bmatrix} w_1 \\ w_2 \\ \mu \end{bmatrix} = \begin{bmatrix} w_1 \\ \mu w_2 \\ -\mu^2 w_1 \\ -\mu^2 w_2 \end{bmatrix}.$$

Thus, the nonlinear oscillator contains an “internal model” for unit amplitude sinusoidal motion of arbitrary phase and period, a property which enables it to asymptotically reproduce the kind of feedback laws needed to shape the steady-state response of the closed-loop system designed above. The methods used in this example actually extend quite far, underscoring the utility of these concepts for the solvability of output regulation problems with real parametric uncertainty.

(i) there exist C^k (with $k \geq 1$) solutions $\pi : W_0 \rightarrow \mathfrak{R}^n$ and $c : W_0 \rightarrow \mathfrak{R}^m$ (where $W_0 \subset W$ is a neighborhood of $w = 0$), with $\pi(0) = 0$ and $c(0) = 0$, of the regulator equations (1.10)

(ii) there exist an integer ν , a neighborhood Ξ_0 of the origin in \mathfrak{R}^ν , a C^k vector field $\varphi : \Xi_0 \rightarrow T\Xi_0$ and a C^k mapping $\gamma : \Xi_0 \rightarrow \mathfrak{R}^m$, with $\varphi(0) = 0$ and $\gamma(0) = 0$, such that

$$\begin{aligned} \dot{\xi} &= \varphi(\xi) \\ u &= \gamma(\xi) \end{aligned} \tag{1.14}$$

is locally exponentially detectable at $\xi = 0$ and $\{W_0, s, c\}$ is immersed into $\{\Xi_0, \varphi, \gamma\}$,

(iii) the linear approximation of

$$A = \frac{\partial f}{\partial x}(0, 0, 0), \quad B = \frac{\partial f}{\partial u}(0, 0, 0), \quad C = \frac{\partial h}{\partial x}(0, 0).$$

at the equilibrium $(x, u, w) = (0, 0, 0)$ is stabilizable and detectable, and the matrix

$$\left(\begin{bmatrix} A - \lambda I & B \\ C & 0 \end{bmatrix} \right) \tag{1.15}$$

is nonsingular for each eigenvalue λ of

$$\Phi = \frac{\partial \varphi}{\partial \xi}(0)$$

having nonnegative real part.

As a special case, consider a system modeled by equations of the form

$$\begin{aligned} \dot{x} &= f(x, u, w, \mu) \\ e &= h(x, w, \mu) \end{aligned} \tag{1.16}$$

with state $x \in \mathbb{R}^n$, control input $u \in \mathbb{R}^m$, regulated output $e \in \mathbb{R}^m$, subject to an exogenous disturbance input $w \in \mathbb{R}^d$, in which $\mu \in \mathcal{P} \subset \mathbb{R}^p$ is a vector of unknown parameters and \mathcal{P} is compact set. $f(x, u, w, \mu)$ and $h(x, w, \mu)$ are C^k functions of their arguments (for some large k), and $f(0, 0, 0, \mu) = 0$ and $h(0, 0, \mu) = 0$ for each value of μ . Without loss of generality, we suppose $0 \in \text{int}(\mathcal{P})$. The exosystem

$$\dot{w} = Sw \tag{1.17}$$

is assumed to be *neutrally stable*.

The control input to (1.16) is to be provided by a controller modeled by equations of the form

$$\begin{aligned} \dot{\xi} &= \eta(\xi, e) \\ u &= \theta(\xi) \end{aligned} \tag{1.18}$$

with state $\xi \in \mathbb{R}^\nu$, in which $\eta(\xi, e)$ and $\theta(\xi)$ are C^k functions of their arguments, and $\eta(0, 0) = 0$, $\theta(0) = 0$.

In order to motivate some of our subsequent hypotheses, we recall first a *necessary* condition for the solution of the problem of *structurally stable* output regulation, which is indeed a prerequisite for *robust* regulation.

Structurally stable local output regulation. Given a nonlinear system of the form (1.16) with exosystem

$$\dot{w} = s(w), \tag{1.19}$$

find a controller of the form

$$\begin{aligned} \dot{\xi} &= \eta(\xi, e) \\ u &= \theta(\xi) \end{aligned} \tag{1.20}$$

such that, for some neighborhood \mathcal{P} of $\mu = 0$ in \mathbb{R}^p and for each $\mu \in \mathcal{P}$:

(a) the equilibrium $(x, \xi) = (0, 0)$ of the unforced closed loop system

$$\begin{aligned} \dot{x} &= f(x, \theta(\xi), 0, \mu) \\ \dot{\xi} &= \eta(\xi, h(x, 0, \mu)) \end{aligned}$$

is locally asymptotically stable in the first approximation,

(b) the forced closed loop system

$$\begin{aligned} \dot{x} &= f(x, \theta(\xi), w, \mu) \\ \dot{\xi} &= \eta(\xi, h(x, w, \mu)) \\ \dot{w} &= s(w) \end{aligned}$$

is such that

$$\lim_{t \rightarrow \infty} e(t) = 0$$

for each initial condition $(x(0), \xi(0), w(0))$ in a neighborhood of the equilibrium $(0, 0, 0)$.

The following result provides necessary and sufficient conditions for the existence of solutions of the problem structurally stable output regulation. Set

$$A(\mu) = \left[\frac{\partial f}{\partial x} \right]_{(0,0,0,\mu)}, \quad B(\mu) = \left[\frac{\partial f}{\partial u} \right]_{(0,0,0,\mu)}, \quad C(\mu) = \left[\frac{\partial h}{\partial x} \right]_{(0,0,\mu)}.$$

Theorem 1.1. *Suppose the exosystem (1.17) is neutrally stable. There exists a solution of the problem of structurally stable output regulation if and only if there exist mappings $x = \pi^a(w, \mu)$ and $u = c^a(w, \mu)$, with $\pi^a(0, \mu) = 0$ and $c^a(0, \mu) = 0$, both defined in a neighborhood $W^\circ \times \mathcal{P}^\circ \subset \mathbb{R}^d \times \mathcal{P}$ of the origin, satisfying the conditions*

$$\begin{aligned} \frac{\partial \pi^a(w, \mu)}{\partial w} S w &= f(\pi^a(w, \mu), c^a(w, \mu), w, \mu) \\ 0 &= h(\pi^a(w, \mu), w, \mu) \end{aligned} \quad (1.21)$$

for all $(w, \mu) \in W^\circ \times \mathcal{P}^\circ$, and such that the autonomous system with output

$$\begin{aligned} \dot{w} &= S w \\ \dot{\mu} &= 0 \\ u &= c^a(w, \mu) \end{aligned} \quad (1.22)$$

is immersed into a system

$$\begin{aligned} \dot{\xi} &= \varphi(\xi) \\ u &= \gamma(\xi), \end{aligned}$$

defined on a neighborhood Ξ° of the origin in \mathbb{R}^ν , in which $\varphi(0) = 0$ and $\gamma(0) = 0$ and the two matrices

$$\Phi = \left[\frac{\partial \varphi}{\partial \xi} \right]_{\xi=0}, \quad \Gamma = \left[\frac{\partial \gamma}{\partial \xi} \right]_{\xi=0}$$

are such that the pair

$$\begin{bmatrix} A(0) & 0 \\ NC(0) & \Phi \end{bmatrix}, \quad \begin{bmatrix} B(0) \\ 0 \end{bmatrix} \quad (1.23)$$

is stabilizable for some choice of the matrix N , and the pair

$$[C(0) \ 0], \quad \begin{bmatrix} A(0) & B(0)\Gamma \\ 0 & \Phi \end{bmatrix} \quad (1.24)$$

is detectable.

Remark 1.1. *Note that the linear approximation of (1.22) at the equilibrium $(w, \mu) = (0, 0)$ cannot be detectable. In fact, since $c^a(0, \mu) = 0$ by hypothesis,*

$$\frac{\partial}{\partial \mu} c^a(0, \mu) = 0,$$

and the linear approximation in question is characterized by a pair of matrices of the form

$$\begin{bmatrix} * & 0 \end{bmatrix}, \quad \begin{bmatrix} S & 0 \\ 0 & 0 \end{bmatrix}$$

which is indeed not detectable. Thus, it is not possible to have the conditions of the Theorem directly satisfied by the trivial immersion of (1.22) into itself. However, as shown below, (1.22) may be immersed into another system, having a detectable approximation at $\xi = 0$.

Remark 1.2. Note that (1.22) is immersed into a (possibly nonlinear) system having an observable linear approximation if there exists a function $\phi(\zeta_0, \zeta_1, \dots, \zeta_{q-1})$ such that

$$L_s^q c^a(w, \mu) = \phi(c^a(w, \mu), L_s c^a(w, \mu), \dots, L_s^{q-1} c^a(w, \mu)).$$

In particular (see [3]), system (1.22) is immersed into a linear system if and only if, for some set of real numbers a_0, a_1, \dots, a_{q-1} ,

$$L_s^q c^a(w, \mu) = a_0 c^a(w, \mu) + a_1 L_s c^a(w, \mu) + \dots + a_{q-1} L_s^{q-1} c^a(w, \mu), \quad (1.25)$$

for all $(w, \mu) \in W^\circ \times \mathcal{P}^\circ$.

1.2 Boundary Control of Distributed Parameter Systems

One of our longer term goals studied in this research project was the development of a systematic feedback design methodology for distributed parameter systems which would retain some of the intuitive appeal of classical automatic control in a spirit similar to the program pursued for the control of lumped systems.

This program included the development of the concept of zero dynamics for nonlinear distributed parameter systems and of a feedback design theory based on asymptotic properties of the zero dynamics. We have approached this problem based in part on the development of a root-locus methodology for distributed parameter systems given in [93].

In particular, for a very general class of parabolic boundary control systems we were able to present a fairly complete picture of root-locus design methodology based on analysis of the closed loop transfer function. Namely, we were able to identify the open loop zeros and poles of the meromorphic open loop transfer function. Then by introducing a proportional error boundary feedback control law the resulting closed loop poles were determined from the return difference equation. For a single input single output system, we were able to show that the closed loop poles varied from the open loop poles to the open loop zeros as the gain parameter varied from zero to plus or minus infinity depending on the sign of the instantaneous gain. This analysis provided a means for establishing boundary feedback stabilization for minimum phase systems based on fairly simple root-locus design methods.

Based on this work we were able to identify a preliminary definition of zero dynamics for boundary control systems which provides an explicit representation of the zero dynamics as a distributed system whose dynamics are governed by the zeros of the open loop system. Setting notation, consider a general linear or nonlinear distributed parameter system

$$\dot{w} = A(w) \quad (1.26)$$

with inputs and outputs

$$u(t) = B(w)(t), \quad y(t) = C(w)(t)$$

and initial conditions

$$w(0) = w_0.$$

Associated with this system we define the zero dynamics to be the system with the output constrained to be zero. i.e., $C(w)(t) = 0$. In particular, if w_0 satisfies the constraint $C(w_0)(0) = 0$ and $w(t)$ is a solution of the zero dynamics, then $u(t) = B(w)(t)$ is a control which “maintains” the constraint $y(t) = 0$.

This can be viewed within the context of root-locus as follows. We introduce a proportional error feedback in the form

$$u = -ky, \quad k \in \mathbb{R}.$$

This provides a closed loop system

$$\begin{aligned} \dot{w} &= A(w) \\ B(w)(t) + kC(w)(t) &= 0 \\ w(0) &= w_0. \end{aligned} \tag{1.27}$$

For this closed loop system, we see that the uncontrolled problem is obtained when $k = 0$ and in the high gain limit, at least at a formal level we obtain the zero dynamics as k tends to infinity

$$\begin{aligned} \dot{w} &= A(w) \\ C(w)(t) &= 0 \\ w(0) &= w_0. \end{aligned} \tag{1.28}$$

This turns out to be a very natural definition of zero dynamics within the context of boundary feedback control problems for distributed parameter systems governed by partial differential equations. As in the finite dimensional case, we have been able to prove, under appropriate hypotheses, that as we tune a gain parameter k , the closed-loop trajectories approach the trajectories of the zero dynamics. For linear systems we have been able to prove this result based on our root-locus analysis in [93]. For nonlinear systems, in particular for a boundary controlled Burgers’ equation, we have been able to prove a result of this type in [89, 90] using semigroup methods. These results required that the initial data be sufficiently small and smooth. More recently, based on our work in [83], we have been able to extend these result to include arbitrary L^2 initial data using energy methods and Galerkin approximations. This work is currently in press. Based on this analysis we have been able to carryout significant numerical simulations and testing as proposed in our research objectives for this effort.

Setting notation, the forced and controlled Burgers' equation on the finite interval $(0, 1)$ is

$$w_t - \epsilon w_{xx} + (f(w))_x = h(x, t),$$

$$w(x, 0) = \varphi(x), \quad \varphi \in L^2(0, 1)$$

$$U(t) = \begin{pmatrix} -w_x(0, t) \\ w_x(1, t) \end{pmatrix} \in \mathfrak{R}^2,$$

$$Y(t) = \begin{pmatrix} w(0, t) \\ w(1, t) \end{pmatrix} \in \mathfrak{R}^2,$$

where $f(w) = \frac{w^2}{2}$.

We introduce a feedback mechanism by the law:

$$U(t) = - \begin{pmatrix} k_0 & 0 \\ 0 & k_1 \end{pmatrix} Y(t), \quad t \in [0, \infty),$$

where $k_0 > 0, k_1 > 0$ are the gain parameters. This feedback law can be rewritten in the form of "radiation" boundary conditions

$$w_x(0, t) - k_0 w(0, t) = 0$$

$$w_x(1, t) + k_1 w(1, t) = 0.$$

The zero dynamics is defined by the condition that the output be constrained to be zero:

$$Y(t) = 0, \quad t \in [0, \infty).$$

This condition, which formally corresponds to passing k_0 and k_1 to infinity, gives the Dirichlet boundary conditions

$$w(0, t) = w(1, t) = 0, \quad t \in [0, \infty).$$

Closed Loop System

$$w_t - \epsilon w_{xx} + (f(w))_x = h(x, t), \tag{1.29}$$

$$w(x, 0) = \varphi(x), \quad \varphi \in L^2(0, 1)$$

$$-w_x(0, t) + k_0 w(0, t) = 0$$

$$w_x(1, t) + k_1 w(1, t) = 0$$

and

The Zero Dynamics

$$\begin{aligned}
w_t - \epsilon w_{xx} + (f(w))_x &= h(x, t), \\
w(x, 0) &= \varphi(x), \quad \varphi \in L^2(0, 1) \\
w(0, t) &= 0 \\
w(1, t) &= 0
\end{aligned}$$

Let $w^k(x, t)$ denote the solution of the closed loop boundary control problem corresponding to (k_0, k_1) and $w(x, t)$ of the zero dynamics problem.

Assume that φ and h in both problems are the same. Then

$$\sup_{t \in [0, T]} \|w^k(t) - w(t)\| \xrightarrow{k_0, k_1 \rightarrow \infty} 0.$$

If in addition, the forcing term h satisfies the extra condition:

$$h_t \in L^2([0, 1] \times [t_0, T])$$

then we can show

$$\sup_{t \in [t_0, T]} \|w^k(t) - w(t)\|_{H^1(0,1)} \xrightarrow{k_0, k_1 \rightarrow \infty} 0$$

for all $t_0 > 0$.

Due to the embedding $H^1(0, 1) \subset C[0, 1]$, this implies that for $t > 0$

$$\max_{x \in [0,1]} \sup_{t \in [t_0, T]} |w^k(x, t) - w(x, t)| \xrightarrow{k_0, k_1 \rightarrow \infty} 0.$$

Commentary on the proof of L^2 convergence:

We have

$$w_t^k - \epsilon w_{xx}^k + f(w^k)_x = h(x)$$

$$w_x^k(0, t) - k_0 w^k(0, t) = 0$$

$$w_x^k(1, t) + k_1 w^k(1, t) = 0$$

$$w^k(x, 0) = \phi(x),$$

and

$$w_t^0 - \epsilon w_{xx}^0 + f(w^0)_x = h(x)$$

$$w^0(0, t) = 0$$

$$w^0(1, t) = 0$$

$$w^0(x, 0) = \phi(x),$$

We let

$$u(x, t) = w^k(x, t) - w^0(x, t)$$

and show that

$$\lim_{k_0, k_1 \rightarrow \infty} \|u(t)\| = 0, \quad \text{uniformly in } t \in [0, T].$$

It follows that u satisfies

$$u_t - \epsilon u_{xx} + (f(w^k) - f(w^0))_x$$

$$u_x(0, t) - k_0 u(0, t) = -w_x^0(0, t)$$

$$u_x(1, t) + k_0 u(1, t) = -w_x^0(1, t)$$

$$u(x, 0) = 0.$$

Taking the inner product of both sides of the above equation with u we obtain

$$\begin{aligned} & \int_0^1 u_t u \, dx - \epsilon \int_0^1 u_{xx} u \, dx \\ & + \int_0^1 [f(w^k) - f(w^0)]_x u \, dx \end{aligned}$$

It is easy to see that

$$\int_0^1 u_t u \, dx = \frac{1}{2} \frac{d}{dt} \|u\|^2,$$

and by integration by parts

$$\begin{aligned} - \int_0^1 u_{xx} u \, dx &= \int_0^1 u_x^2 \, dx \\ & - u(1, t) u_x(1, t) + u(0, t) u_x(0, t). \end{aligned}$$

$$\begin{aligned} \frac{1}{2} \frac{d}{dt} \|u\|^2 + \epsilon \|u\|_1^2 &= - \int_0^1 [f(w^k) - f(w^0)]_x u \, dx \\ & + \epsilon F(t), \end{aligned}$$

where

$$\begin{aligned} F(t) &= u(0, t) w_x^0(0, t) - u(1, t) w_x^0(1, t) \\ &= w^k(0, t) w_x^0(0, t) - w^k(1, t) w_x^0(1, t). \end{aligned}$$

Now using a variety of estimates (Poincare, Cauchy-Schwartz, Young, Sobolev, Gronwall, etc), we estimate all the terms on the right and arrive at an expression

$$\|u(t)\|^2 \leq C_1(t_0, T) \left(\frac{1}{\sqrt{k_0}} + \frac{1}{\sqrt{k_1}} \right) + C_2(t_0, T) \|u(t_0)\|^2$$

for all $0 < t_0 < T < \infty$. Here $C_1(t_0, T)$ is a continuous function of $t_0 > 0$ and behaves like $t_0^{-1/2}$ near $t_0 = 0$. C_2 is continuous in t_0 and bounded at $t_0 = 0$.

Consider the following statements:

1. $\|u(t)\| \leq \|w^k(t) - \phi\| + \|w^0(t) - \phi\|$.
2. $w^k(t) \xrightarrow{t \rightarrow 0} \phi$ in $L^2(0, 1)$ uniformly with respect to k_0 and k_1 .
3. The above convergence is uniform with respect to k_0 and k_1 if $k_0, k_1 \in [\tilde{k}, \infty)$, where $\tilde{k} > 0$.
4. Similarly, $\|w^0(t) - \phi\| \xrightarrow{t \rightarrow 0} 0$.
5. $w^k(t)$ and $w^0(t)$ are continuous functions of t in L^2 -norm.
6. It follows from parts 1.- 4. that

$$\|u(t_0)\| \xrightarrow{t_0 \rightarrow 0} 0$$

uniformly with respect to k_0 and k_1 , if

$$k_0, k_1 \in [\tilde{k}, \infty), \tilde{k} > 0.$$

Take any $\delta > 0$, then from statement 6. above, it follows that we can select $t_0 \in (0, T]$ such that

$$C_2(t_0, T) \|u(t_0)\| \leq \frac{\delta}{2}, \text{ for all } k_0, k_1 \in [\tilde{k}, \infty).$$

Now we can also select k_0 and k_1 so large that

$$C_1(t_0, T) \left(\frac{1}{\sqrt{k_0}} + \frac{1}{\sqrt{k_1}} \right) \leq \frac{\delta}{2}.$$

Thus we have

$$\|u(t)\|^2 \leq \delta,$$

and it follows that

$$\lim_{k_0, k_1 \rightarrow \infty} \|u(t)\| = 0 \text{ for any } t > 0$$

and the convergence is uniform on any interval $[t_0, T]$ with $t_0 > 0$.

Furthermore, due to statement 6. above, we see that the convergence takes place on the whole interval $[0, T]$.

As an example consider the controlled viscous Burgers' system (1.29) with disturbance $f = 0$ and initial condition $w(x, 0) = x^2(1 - x)^2$

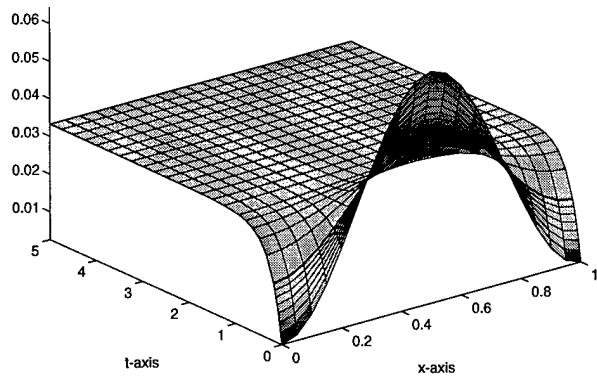
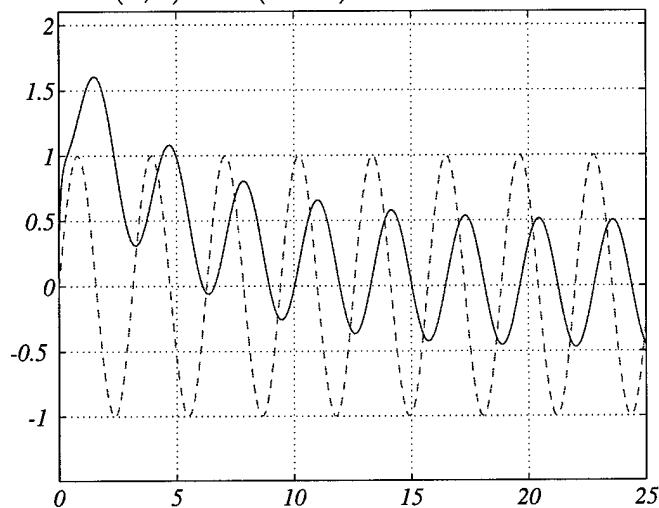

$$k_0 = k_1 = 0$$

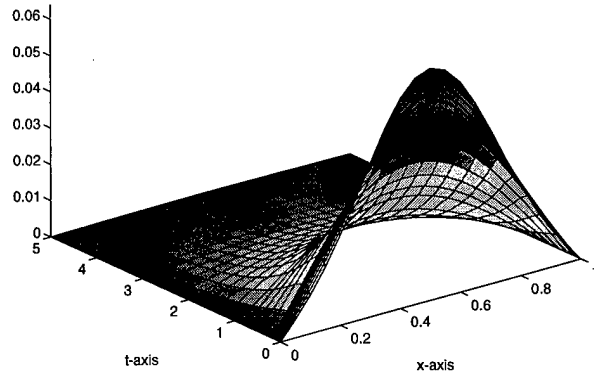

$$k_0 = k_1 = \infty$$

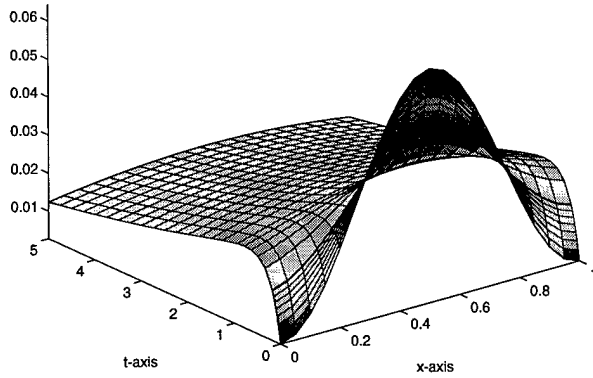

$$k_0 = k_1 = 1$$

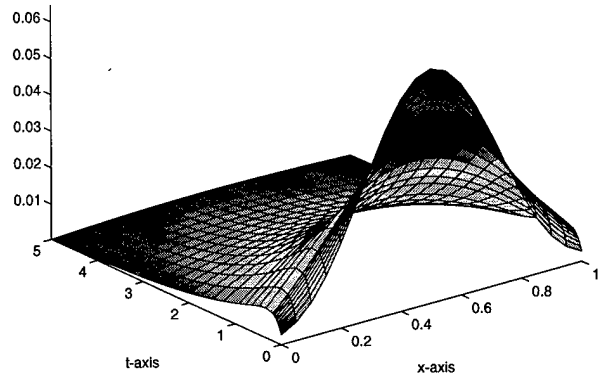

$$k_0 = k_1 = 10$$

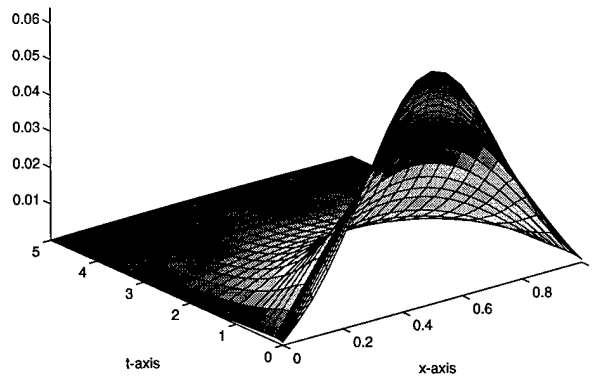

$$k_0 = k_1 = 100$$

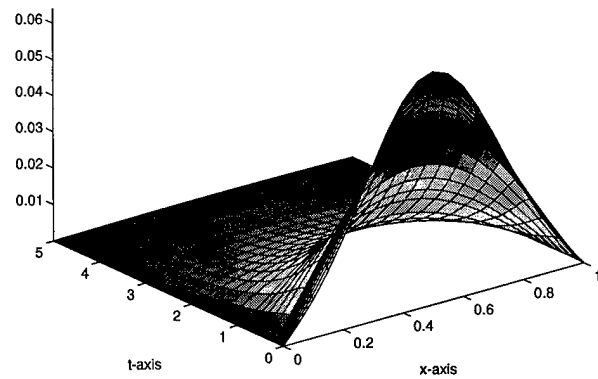

$$k_0 = k_1 = 1000$$

The first figure depicts the open loop system dynamics, i.e., $k_0 = 0$, $k_1 = 0$ and the trajectories of the zero dynamics system corresponding to $k_0 = k_1 = \infty$. Note that the solution of the uncontrolled open loop system approaches the nonzero steady state

$$w(x, t) = .0333 = (\phi, 1) = \int_0^1 x^2(1-x)^2 dx.$$

In general for the Burgers' system (1.29) the nonzero equilibrium guaranteed by the Center Manifold Theorem appears to depend on the value of ϵ unlike the linearization of the Burgers' system (the heat equation with homogeneous Neumann boundary conditions) for which it is known that the steady state is always equal to the integral of the initial data, for all ϵ . In the second and third figures, we have depicted the dynamics of the closed loop system for various values of the gain parameters $k \equiv k_0 = k_1 = 1, 10, 100, 1000$. We have computed the

maximum error between the trajectories of the closed loop dynamics and the zero dynamics on a uniform grid in $x - t$ space.

k	1	10	100	1000
error	.025	.0088	.0012	.0001

In the next example, we consider the controlled viscous Burgers' system (1.29) with $f(x) = (0.5) \sin(2\pi x)$ and initial condition $2x^2(1 - x)^2$.

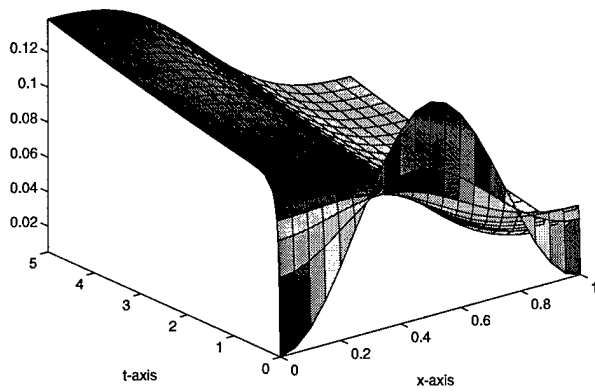

$k_0 = k_1 = 0$

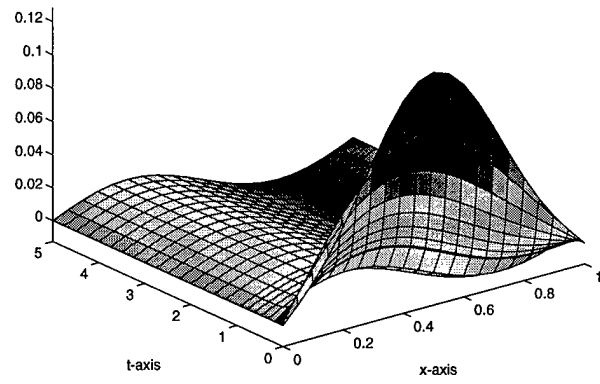

$k_0 = k_1 = \infty$

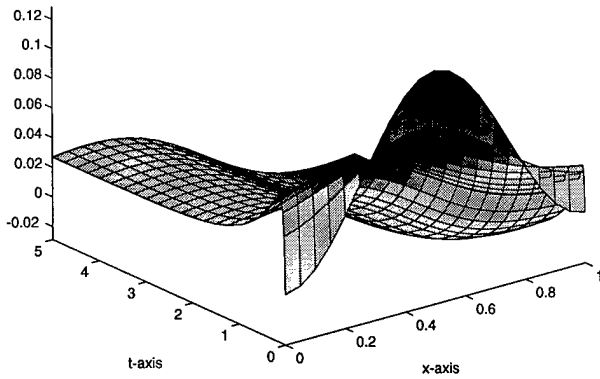

$k_0 = k_1 = 1$

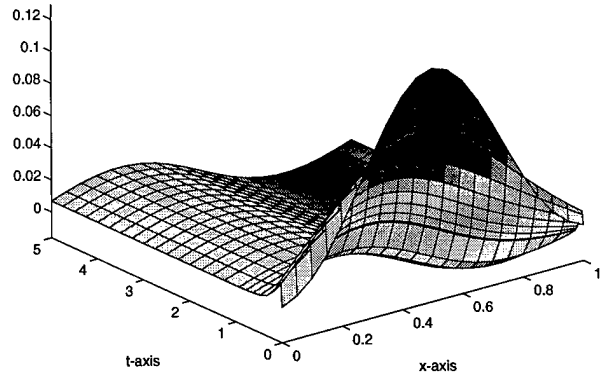

$k_0 = k_1 = 10$

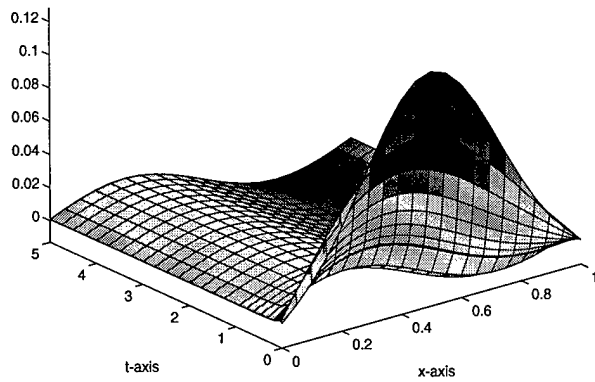

$k_0 = k_1 = 100$

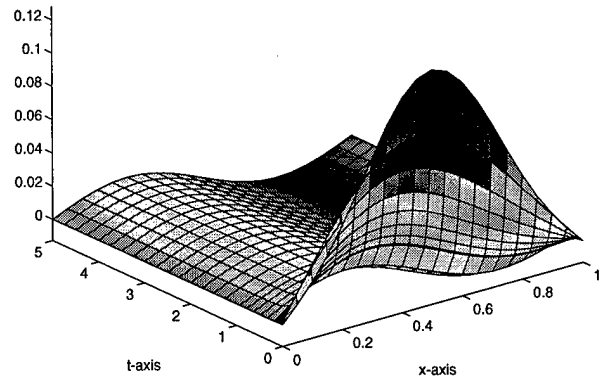

$k_0 = k_1 = 1000$

k	1	10	100	1000
error	.0687	.0220	.0029	.0003

As a final example we consider a Burgers' system with distributional forcing term $f(x) = (0.25) \delta_{x_0}(x)$ with $x_0 = 0.75$ and zero initial condition.

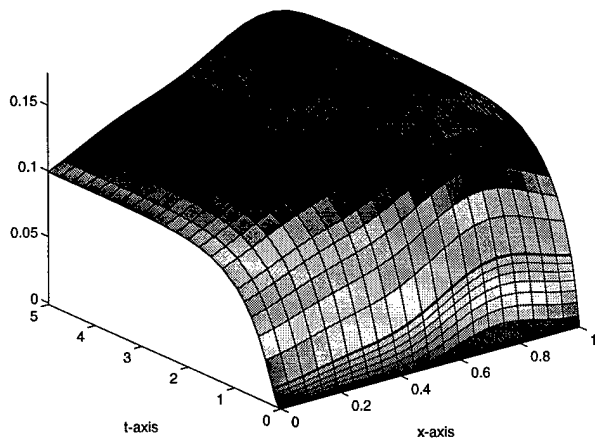

$k_0 = k_1 = 1$

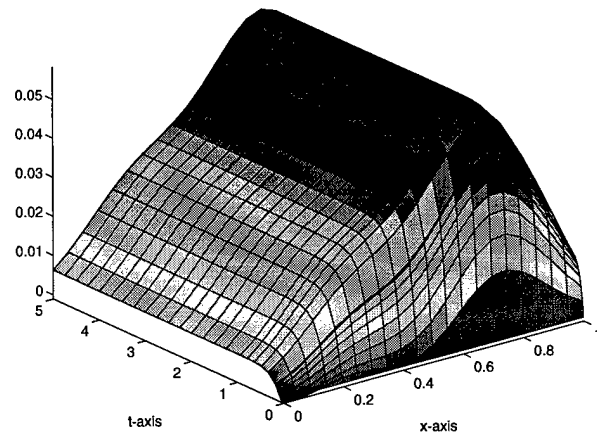

$k_0 = k_1 = 10$

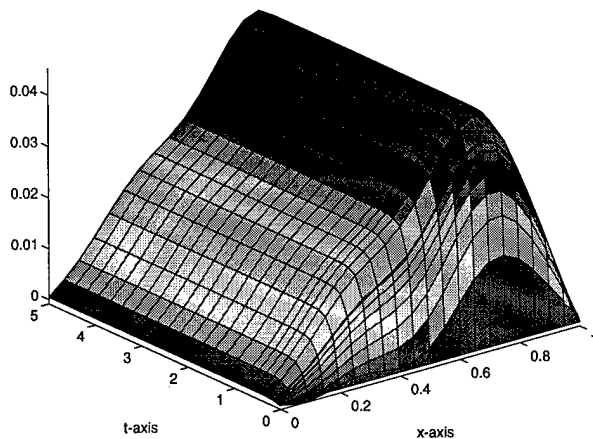

$$k_0 = k_1 = 100$$

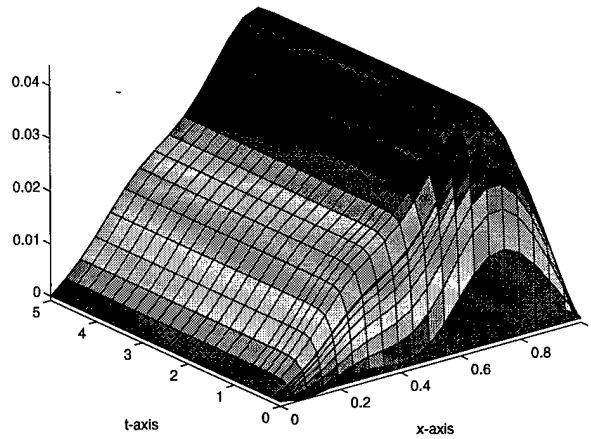

$$k_0 = k_1 = 1000$$

k	1	10	100	1000
error	.144	.018	.002	.0002

In the paper [91] we have extended these results on convergence of trajectories, at least for small initial data, to a general class of one dimensional convection reaction diffusion equations and we are currently complete in the process of extending these results, for all finite energy initial data, to a general class of convective reaction diffusion equations on bounded domains in \mathbb{R}^n .

1.3 Boundary Stabilization for Nonlinear Distributed Parameter Systems

Motivated in part by problems of flow control and combustion control, where nonlinear effects actually can improve mixing, there has been considerable attention given in the literature to the study of asymptotic or steady state properties of solutions of nonlinear distributed parameter systems, such as Navier-Stokes equations, which contain both nonlinear convective terms and diffusive terms. In addition, the need to control systems in which the rigid aerodynamics are coupled with the effects of fluid flow and flexible structural modes also underscores the importance of developing a feedback design methodology capable of producing controllers for nonlinear distributed parameter systems in a systematic way.

Of considerable interest then is the question of the effect of boundary control, modeling the use of point actuators and sensors, in controlling or influencing the steady-state response of forced nonlinear distributed parameter systems. In the recent paper [83] we consider an example of such a boundary control problem for the forced Burgers' equation on a finite interval. This remarkable system (see e.g. [76]) has been studied for some time [77] and was extensively developed by Burgers [78] as a simplified fluid flow model which nonetheless

exhibits some of the important aspects of turbulence. It was later derived by Lighthill [79] as a second order approximation to the one dimensional unsteady Navier-Stokes equation.

The uncontrolled problem studied in [83] corresponds to Burgers' equation with homogeneous Neumann boundary conditions. Since constants are global solutions we see that the uncontrolled system is not asymptotically stable. For this reason the question of feedback regularization becomes an important issue. In particular, we are interested in introducing a boundary feedback control, delivering a closed loop system, for which there is a globally defined dynamics in L^2 . Motivated, in part, by classical feedback design and root locus for finite dimensional control systems, we formally employ a simple proportional error feedback control law. For the linearization about zero of the Burgers' system, i.e., the one dimensional heat equation, such a control law can be rigorously developed based on the work in [94]. Indeed, for the linear problem this proportional error feedback exponentially stabilizes the closed loop system in all of L^2 . The boundary feedback control is equivalent to introducing radiation boundary conditions at each end of the rod with parameters in the boundary conditions considered as "gains" or control parameters. In our work we have demonstrated that this same feedback scheme provides a closed Burgers' system with a globally defined dynamics which for the unforced problem is globally Lyapunov stable. Thus this example demonstrates that boundary control can significantly regularize nonlinear distributed parameter systems; including systems of hydrodynamic type which contain nonlinear convective terms.

For small initial data in L^2 , restrictions on the forcing terms can be considerably relaxed and we show that there is a globally (in time) defined dynamics possessing a local absorbing ball. For stationary forcing terms we have shown that the corresponding nonlinear semigroups define compact operators for all positive time, from which it was possible to deduce the existence of a local attractor with finite fractal and finite Hausdorff dimension. As a corollary to this analysis, we also showed that the unforced system is locally exponentially stable in L^2 , representing a marked improvement over a similar result for small initial data in $H^1(0, 1)$ reported in [97].

Concerning the method of proof, it is well-known [80] that the one-dimensional Burgers' equation with an external forcing term can be reduced by the Hopf-Cole substitution to the one-dimensional heat equation with a "potential" term, which might seem to offer a straightforward method for asymptotic analysis. However, for Neumann or radiation boundary conditions, this substitution introduces quadratic nonlinearities at the boundary of the interval, in sharp contrast with the case of Dirichlet boundary conditions. Also, a complicating feature, which arises for boundary conditions which are neither Dirichlet nor periodic, is a nonlinear term which persists in the energy balance relation and presents considerable difficulty in obtaining a priori estimates from which the existence of an absorbing ball and the convergence of Galerkin approximations can be established as in [73, 81].

Our method can be briefly characterized in the following way. The state space for our system is $L^2(0, 1)$ and for arbitrary initial data in $L^2(0, 1)$ we first prove local in time existence and uniqueness of the weak solution. On this step we use the energy method and Galerkin approximations following closely the classical approach developed in [73, 75]. The energy estimates obtained for general L^2 initial data in this step are local in time, and for this reason

we cannot prove global existence of solutions in the first step. We also stress that since our state space is $L^2(0, 1)$ we cannot use well known existence results for quasilinear parabolic equations in the spaces of Hölder continuous functions based on the Leray-Schauder fixed point theorem [75].

Our second step, which is technically the most involved, is the systematic investigation of the regularity properties of the local solution. In other words, we study the smoothing properties of the local in time dynamics. We show, in particular, that under appropriate assumptions on the forcing term, the weak solution is, in fact, classical for positive values of time. Our method also provides upper bounds for the rate at which the derivatives of the solution can blow up as $t \rightarrow 0$. Certainly, the smoothing properties of parabolic equations is a well known phenomenon which has been studied extensively in the literature. In particular, the smoothing property for Burgers' equation with periodic boundary conditions is very well explained in [67]. However, as we show below, the proof of this property and derivation of the existence of higher order derivatives of the solution requires a significant effort when a boundary feedback control is implemented.

Finally, we combine the local in time existence and regularity result with a maximum principle argument to obtain the global in time existence and regularity of solutions.

Yet another result obtained during this research effort concerns the effect of boundary control on the structure of attractors for Burgers' equation. In the, soon to be published, work [92], we prove that the structure of the attractor is, in general, nontrivial. Indeed, for a special class of forcing terms we are able to show that as the gain parameters in the boundary feedback control are increased from small positive values to large positive values, the number of stationary solutions vary from three to one. This is in keeping with our results on conergence of attractors, discussed in the last subsection, where it can be shown that the zero dynamics systems has a single, global, asymptotically stable, equilibrium.

1.4 Output Regulation for Linear Distributed Parameter Systems

In general, the ability to systematically control or influence nonlinear effects would make a substantial contribution to existing and emerging commercial and defense research and development programs. Notable examples, widely appreciated within the aerospace industry, include the development of flight controllers for high angle-of-attack or high agility aircraft. Indeed, the importance of including the nonlinear behavior of aerodynamic parameters, such as the coefficient of lift, as a function of the angle-of-attack has long been recognized since at high angles-of-attack, wind angle moments also exhibit nonlinear effects which cannot be ignored. Another area of interest is the control of flutter, which can shorten the life cycle of aircraft and aircraft parts. Indeed, one example of the potential impact of nonlinear control in problems of flow control is in the control of instabilities in the unsteady separated shear layer, which has been experimentally shown to greatly influence stall and lift behavior at high angles of attack.

It is worth noting, however, that the active control in experiments, such as Batill and Mueller [69], is based on a priori harmonic forcing, while in nonlinear systems with resonance it is known that simple harmonic forcing will not necessarily produce the desired response

(see e.g. [12] for an analysis of the steady state response of nonlinear systems by center manifold methods). This point was also illustrated theoretically by Keefe [30], who showed that the success of a priori control for the Ginzburg-Landau equation was dependent on the initial state of the system, which of course may not be controlled or even known, and that therefore undesirable responses are to be expected in the nonlinear regime. Moreover, the computation by Fuglsang and Cain [9] of flow over an open cavity suggests that harmonic forcing at non-resonant harmonic frequencies can produce a limit cycle or chaotic response that is far more severe than the natural harmonic resonance.

One of the central problems in control theory is to control a fixed plant in order to have its output track a reference signal (and/or reject a disturbance) produced by an external generator or exogenous system. Generally two versions of this problem are considered. In the first, the state feedback regulator problem, the controller is provided with full information of the state of the plant and exosystem. For the second, more realistic error feedback regulator problem, only the components of the error are available for measurement. For linear finite dimensional systems it has been shown by Francis [104] that the solvability of the regulator problems is equivalent to the solvability of a pair of linear matrix equations. This in turn can be characterized as a property of the transmission polynomials of the composite system formed from the plant and the exosystem as it was shown by Hautus [106]. Francis and Wonham [105] have also shown that any regulator that solves the error feedback problem has to incorporate a model of the exogenous system generating the reference signal which is to be tracked and/or the disturbance that must be rejected. This property is known as the internal model principle.

Similar results have been established for finite dimensional nonlinear systems in [12] (see also [107]) in case the plant is exponentially stabilizable and the exosystem has bounded trajectories that do not trivially converge to zero. In particular, it is shown in [12] that the solvability conditions given by Francis in the linear case can be naturally generalized to the solvability of a pair of nonlinear equations – the regulator equations – that express the existence of a local manifold on which the actual and reference outputs coincide and which can be rendered invariant using feedback. The paper [12] also contains an interpretation Hautus' result in the nonlinear setting in terms of the notion of zero dynamics. They expressed the solvability conditions as a special property of the zero dynamics of the system composed from the plant and the exosystem with the tracking error as its output. In [12] it is proven that the nonlinear regulator equations are solvable if and only if the zero dynamics of this composite system contains a controlled invariant submanifold on which the dynamics is a diffeomorphic copy of the flow of the exosystem.

In our forthcoming work [102] we have developed a geometric theory of output feedback regulation for infinite dimensional linear control systems assuming that the control and observation operators are bounded. In particular we have obtained results characterizing the solvability of both state and error feedback regulator problems in terms of the solvability of certain equations referred to as the regulator equations. The main difficulties that arise in extending the work in [12] to the distributed parameter case are obvious: the phase space is infinite dimensional; the state operator is unbounded and consequently only densely defined; there is no direct analog of the Jordan decomposition consequently some care must

be exercised in dealing with the spectra of certain composite systems.

To motivate our development of the linear regulator theory for bounded inputs and outputs, let us consider a simple example in which we have a plant consisting of a one dimensional heat equation on a finite rod with end points insulated, i.e., Neumann boundary conditions. Our specific objective is to design a feedback law which, for arbitrary initial data, will drive the output – consisting of the average temperature about a fixed point on the rod – in order to track a periodic temperature profile.

For this example, the first of our three basic ingredients, the existence of a steady state response is classical and for the second ingredient, stabilizability, the plant is easily stabilized by a low order feedback. For this example, the third ingredient, shaping the response, is most difficult. Once we have stabilized the system, driving the system with a sinusoid produces an output which converges rapidly to a periodic motion, but unfortunately, the amplitude and phase are not correct. The most important design feature is shaping the output by choosing an appropriate periodic input. However, applying the regulator theory discussed below, the tracking problem is solved immediately.

Consider a controlled SISO one dimensional heat equation on the interval $[0, 1]$:

$$\frac{\partial z}{\partial t}(x, t) = \frac{\partial^2 z}{\partial x^2}(x, t) + Bu(t), \quad (1.1)$$

$$\begin{aligned} \frac{\partial z}{\partial x}(0, t) = 0, \quad \frac{\partial z}{\partial x}(1, t) = 0 \\ z(x, 0) = \phi(x), \end{aligned} \quad (1.2)$$

$$y(t) = Cz. \quad (1.3)$$

We can formulate the system (1.1), (1.3) in the usual (A, B, C) form by choosing

$$\dot{z}(t) = Az(t) + Bu(t),$$

$$y(t) = Cz(t), \text{ (measured output)}$$

$$z(0) = z_0,$$

where

1. The operator $A = d^2/dx^2$ with Neumann boundary conditions defines an unbounded selfadjoint operator in Z specified by the dense domain,

$$\mathcal{D}(A) = \{\phi \in H^2(0, 1) : \phi'(0) = \phi'(1) = 0\}.$$

2. The input corresponds to a spatially uniform temperature input over a small interval about a fixed point $x_0 \in (0, 1)$:

$$Bu = b(x)u \quad (1.4)$$

$$b(x) = \frac{1}{2\nu_0} \chi_{[x_0-\nu_0, x_0+\nu_0]}(x).$$

3. The output corresponds to the average temperature over a small interval about a point $x_1 \in (0, 1)$.

$$C\phi = \int_0^1 c(x)\phi(x) dx \quad (1.5)$$

$$c(x) = \frac{1}{2\nu_1} \chi_{[x_1-\nu_1, x_1+\nu_1]}(x). \quad (1.6)$$

and where $Z = L^2(0, 1)$ is the state of the system, a separable Hilbert space (state space) with inner product

$$\langle \phi, \psi \rangle = \int_0^1 \phi(x)\psi(x) dx.$$

The spectrum of A consists of pure point spectrum

$$\sigma(A) = \{-k^2\pi^2\}_{k=0}^{\infty}$$

with corresponding orthonormal eigenvectors

$$\psi_0(x) = 1 \quad \text{and} \quad \psi_k(x) = \sqrt{2} \cos(k\pi x) \quad \text{for } k \geq 1.$$

In this example, we consider the problem of tracking a sinusoid, $y_r(t) = M \sin(\alpha t)$. Thus for a suitable initial condition $y_r(t)$ is the output of a harmonic oscillator:

$$\begin{aligned} \dot{w} &= Sw, \\ S &= \begin{pmatrix} 0 & \alpha \\ -\alpha & 0 \end{pmatrix}, \\ w(0) &= \begin{bmatrix} 0 \\ M \end{bmatrix}, \\ y_r &= [1 \ 0]w. \end{aligned}$$

The ultimate design objective for this problem would be to find a control u that will force the output $y(t)$ to track the reference trajectory y_r , i.e., so that the error satisfies

$$e(t) = y(t) - y_r(t) \rightarrow 0 \quad \text{as } t \rightarrow \infty.$$

In order to demonstrate the importance of stabilization and shaping the response we first consider choosing an input $u = y_r = M \sin(\alpha t)$, i.e., driving the system with the desired harmonic reference signal. As might be expected, due to the zero eigenvalue which causes the original uncontrolled system not to be asymptotically stable, the controlled output does not oscillate about zero.

For our numerical simulation, we have chosen $x_0 = 3/4$, $x_1 = 1/4$, $\nu_0 = \nu_1 = 1/4$, $M = 1$, $\alpha = 2$ with initial condition $\phi(x) = 4x^2(3/2 - x)$ and we have set the control input $u = \sin(2t)$. Figure 1 contains a plot of the resulting outputs y and y_r while Figure 2 depicts

the error $e = y - y_r$ and Figure 3 depicts the entire solution surface for the heat problem due to this simple harmonic forcing.

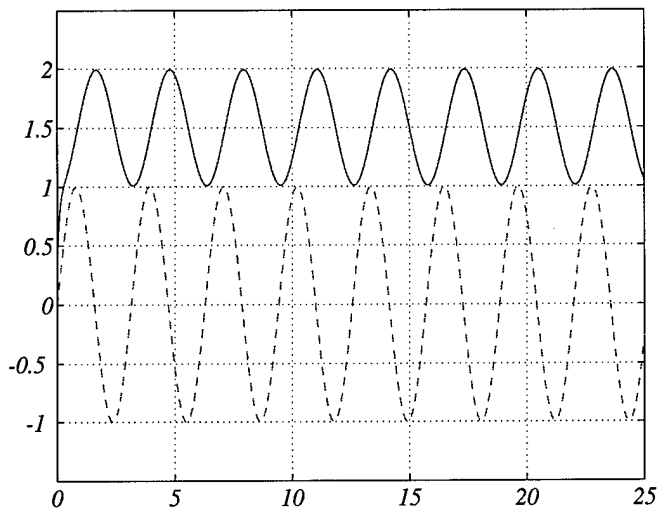

Fig. 1: y (solid line), y_r (dashed line)

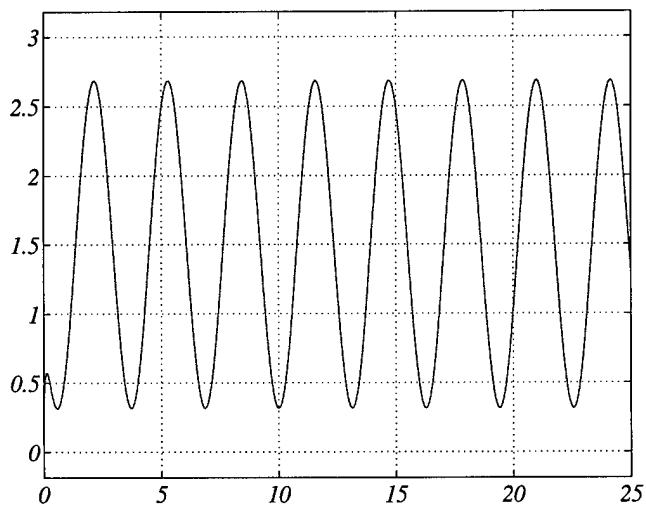

Fig. 2: $e(t)$ for harmonic forcing

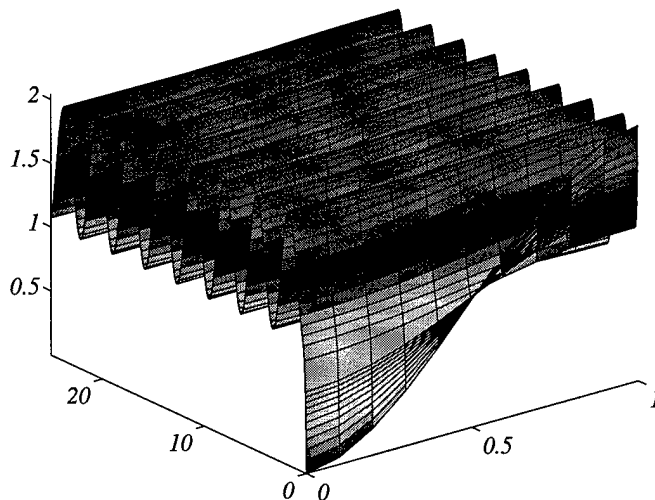

Fig. 3: Solution Surface for $u = \sin(2t)$

Next we incorporate a stabilizing feedback term in the control. Thus we consider a feedback control in the form $u = Kz + M \sin(2t)$ where $u = Kz$ is a stabilizing feedback. A rank one, bounded stabilizing feedback operator for this problem is given by (cf. [103])

$$K\phi = -\beta \langle \phi, 1 \rangle, \quad \beta > 0.$$

Indeed it can be shown that $(A + BK)$ is a discrete Reisz spectral operator with simple spectrum given by $\{-\beta\} \cup \{-k^2\pi^2\}_{k=1}^{\infty}$. In Figures 4 - 6 we have again plotted the resulting outputs, error and solution surface, respectively, with $\beta = 0.2$.

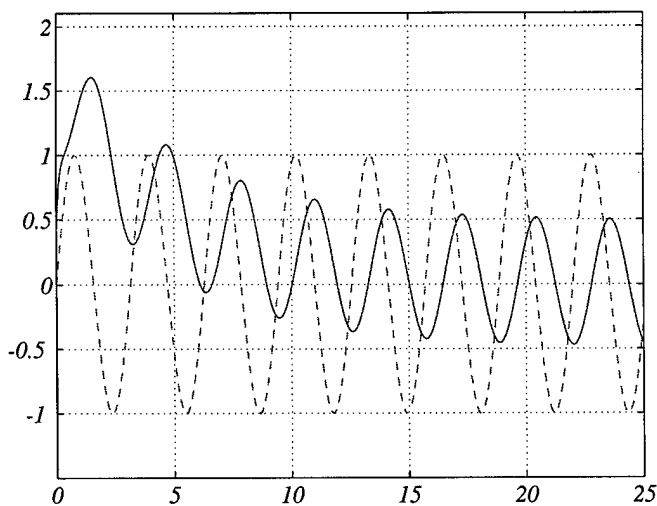

Fig. 4: y (solid line), y_r (dashed line)

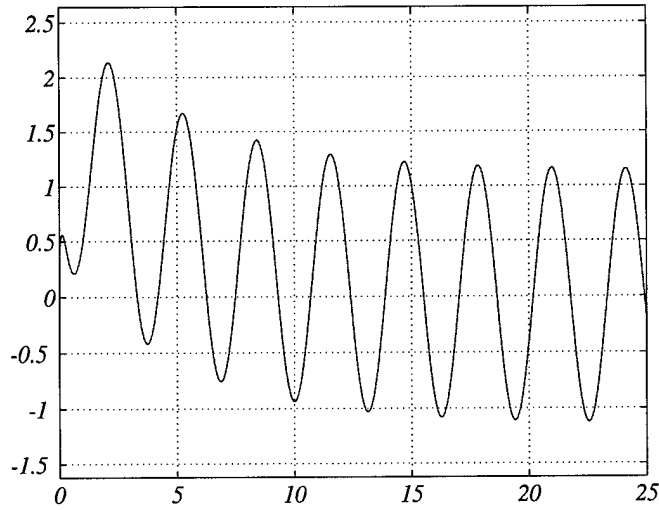

Fig. 5: $e(t)$ harmonic forcing with stability

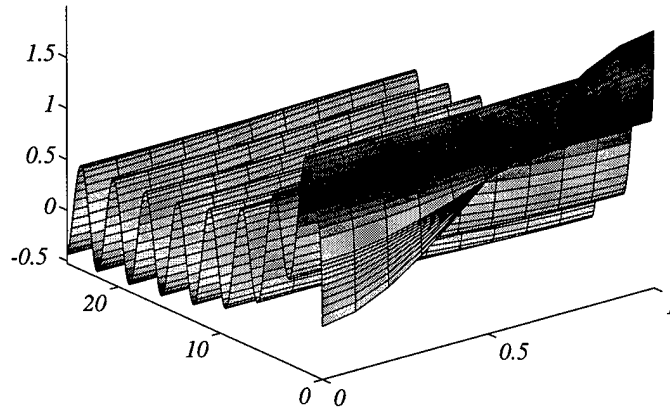

Fig. 6: Solution Surface $u = Kz + \sin(2t)$

The stabilizing feedback has provided an output which now appears to converge to a periodic trajectory about zero, as desired, but the resulting asymptotic amplitude and phase are not correct.

Therefore, as suggested in the statement of the state feedback regulator problem (given in the next section) we consider finding a feedback law in the more general form

$$u = Kz + Lw$$

where K is a stabilizing feedback operator and $L = (\Gamma - K\Pi)$ with $\Pi = [\Pi_1, \Pi_2] \in \mathcal{L}(\mathbb{R}^2, Z)$ and $\Gamma = [\gamma_1, \gamma_2] \in \mathbb{R}^2$ are solutions of the so-called “regulator equations” (described in Theorem 1 below.) In this example the first regulator equation reduces to a pair of coupled

second order ordinary differential equations with boundary conditions,

$$\begin{aligned}
 \Pi_1''(x) + \alpha\Pi_2(x) &= -b(x)\gamma_1 & (1.7) \\
 \Pi_2''(x) - \alpha\Pi_1(x) &= -b(x)\gamma_2. \\
 \Pi_1'(0) = \Pi_1'(1) &= 0 \\
 \Pi_2'(0) = \Pi_2'(1) &= 0.
 \end{aligned}$$

The boundary conditions in (1.7) correspond to the requirements that Π_1 and Π_2 lie in the domain of A .

The parameters γ_1 and γ_2 are chosen to satisfy a second regulator equation, which in this case reduces to the additional constraints

$$\langle c, \Pi_1 \rangle = 1, \quad \langle c, \Pi_2 \rangle = 0. \quad (1.8)$$

These equations can be solved off-line either analytically or numerically. The resulting outputs and solution surface for the system with control $u = Kz + Lw$ are depicted in Figures 7 and 8. In Figure 9 we have plotted the error $e(t) = y(t) - y_r(t)$ and note that the error appears to tend to zero. Indeed, as a result of the center manifold methods applied in our proofs, we expect that the error tends to zero exponentially.

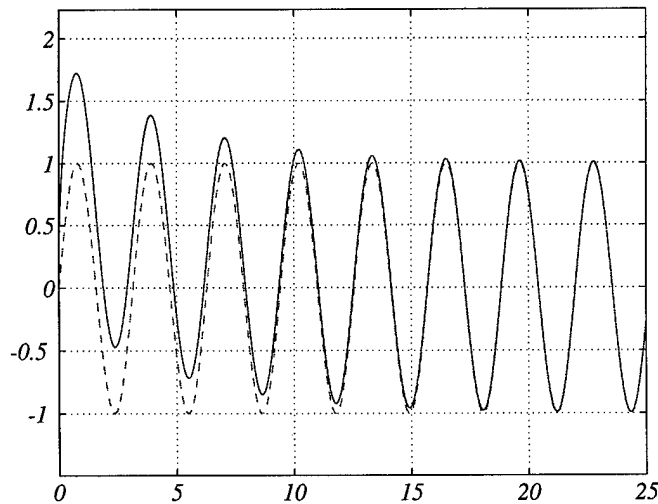

Fig. 7: Graphs of y (solid line), y_r (dashed line)

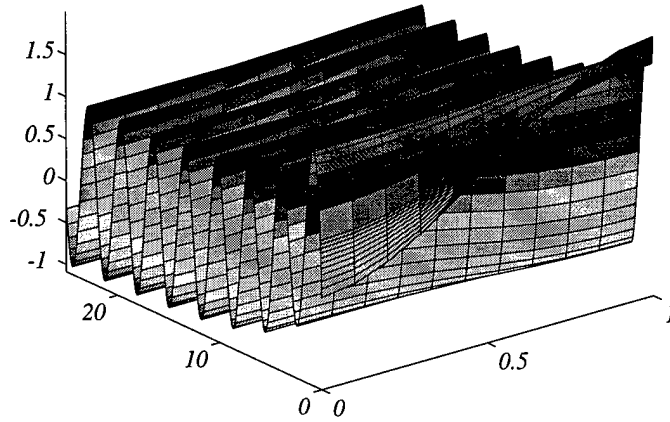

Fig. 8: Solution Surface for $u = Kz + Lw$

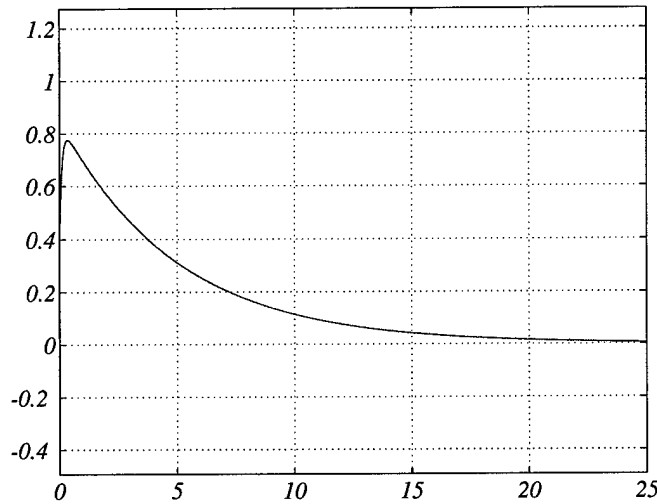

Fig. 9: $e(t)$ using regulator equations

Regulator Problem

Consider a plant described by an abstract distributed parameter control system in Hilbert space:

$$\dot{z}(t) = Az(t) + Bu(t) + d(t), \quad (1.9)$$

$$y(t) = Cz(t), \text{ (measured output)} \quad (1.10)$$

$$z(0) = z_0,$$

where $z \in Z$ is the state of the system, Z is a separable Hilbert space (state space), $u \in U$ is an input, $y \in Y$ is the measured output, U and Y are Hilbert control and output spaces, respectively. A is assumed to be the infinitesimal generator of a strongly continuous semigroup on a Hilbert space Z , $B \in \mathcal{L}(U, Z)$ and $C \in \mathcal{L}(Z, Y)$. Here we use the notation

$\mathcal{L}(W_1, W_2)$ to denote the set of all bounded linear operators from a Hilbert space W_1 to a Hilbert space W_2 . The term $d(t)$ represents a disturbance.

In addition we will assume that there exists a finite dimensional linear system, referred to as the exogenous system (or exosystem), that produces a reference output $y_r(t)$ and which is also used to model the disturbance $d(t)$:

$$\dot{w}(t) = Sw(t) \tag{1.11}$$

$$y_r(t) = Qw(t) \tag{1.12}$$

$$d(t) = Pw(t) \tag{1.13}$$

$$w(0) = w_0. \tag{1.14}$$

Here $S \in \mathcal{L}(\mathbb{R}^k)$, $Q \in \mathcal{L}(\mathbb{R}^k, Y)$ and $P \in \mathcal{L}(\mathbb{R}^k, Z)$.

We will refer to the difference between the measured and reference outputs as the error

$$e(t) = y(t) - y_r(t) = Cz(t) - Qw(t). \tag{1.15}$$

I. Linear State Feedback Regulator Problem:

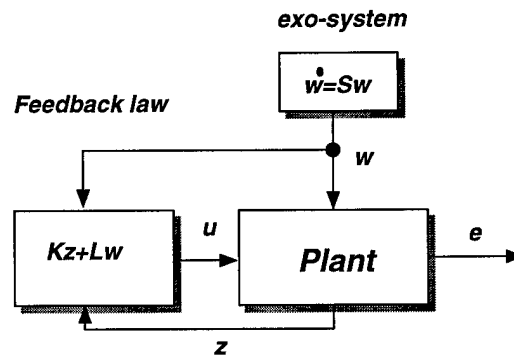

STATE FEEDBACK

Find a feedback control law in the form $u(t) = Kz(t) + Lw(t)$ such that $K \in \mathcal{L}(Z, U)$, $L \in \mathcal{L}(\mathbb{R}^k, U)$ and

I.a $\dot{z}(t) = (A + BK)z(t)$ is stable, i.e. $(A + BK)$ is the infinitesimal generator of an exponentially stable C_0 semigroup.

I.b For the closed loop system

$$\dot{z}(t) = (A + BK)z(t) + (BL + P)w(t),$$

$$\dot{w}(t) = Sw(t),$$

the error

$$e(t) = Cz(t) - Qw(t) \longrightarrow 0 \text{ as } t \rightarrow \infty,$$

for any initial condition in $Z \times \mathbb{R}^k$.

II. Linear Error Feedback Regulator Problem:

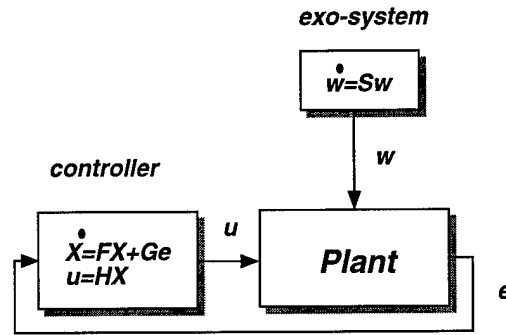

ERROR FEEDBACK

Find an error feedback controller of the form

$$\dot{X}(t) = FX(t) + Ge(t),$$

$$u(t) = HX(t)$$

where $X(t) \in \mathfrak{X}$ for $t \geq 0$, \mathfrak{X} is a Hilbert space, $G \in \mathcal{L}(Y, \mathfrak{X})$, $H \in \mathcal{L}(\mathfrak{X}, U)$ and F is the infinitesimal generator of a C_0 semigroup on \mathfrak{X} with the properties that

II.a The system

$$\dot{z}(t) = Az(t) + BHX(t),$$

$$\dot{X}(t) = FX(t) + Ge(t)$$

is exponentially stable when $w \equiv 0$, i.e. $\begin{bmatrix} A & BH \\ GC & F \end{bmatrix}$ is the infinitesimal generator of an exponentially stable C_0 semigroup, and

II.b for the closed loop system

$$\dot{z}(t) = Az(t) + BHX(t) + Pw(t),$$

$$\dot{X}(t) = GCz(t) + FX(t) - GQw(t),$$

$$\dot{w}(t) = Sw(t)$$

the error

$$e(t) = Cz(t) - Qw(t) \longrightarrow 0 \text{ as } t \rightarrow \infty,$$

for any initial condition in $Z \times \mathfrak{X} \times \mathbb{R}^k$.

We impose the following standard assumptions.

Three basic assumptions:

H1 Without loss of generality, we assume that $\sigma(S)$ is contained in the closed right half plane. (Modes corresponding to spectrum in the open left half plane decay exponentially to zero.)

H2 The pair (A, B) is exponentially stabilizable, i.e there exists $K \in \mathcal{L}(Z, U)$ such that $A + BK$ is the infinitesimal generator of an exponentially stable C_0 semigroup,

H3 The pair

$$\left(\begin{bmatrix} A & P \\ 0 & S \end{bmatrix}, [C \quad -Q] \right)$$

is exponentially detectable, i.e there exists $G \in \mathcal{L}(Y, Z \times \mathbb{R}^k)$,

$$G = \begin{bmatrix} G_1 \\ G_2 \end{bmatrix}, \quad G_1 \in \mathcal{L}(Y, Z), \quad G_2 \in \mathcal{L}(Y, \mathbb{R}^k)$$

such that

$$\begin{bmatrix} A & P \\ 0 & S \end{bmatrix} - \begin{bmatrix} G_1 \\ G_2 \end{bmatrix} [C \quad -Q]$$

is the infinitesimal generator of an exponentially stable C_0 semigroup.

The first main results from [102] characterizing the solvability of the regulator problems for linear distributed parameter systems are given in Theorems 1 and 2, respectively.

THEOREM 1: *Let H1 and H2 hold. The linear state feedback regulator problem is solvable if and only if there exist mappings $\Pi \in \mathcal{L}(\mathbb{R}^k, Z)$ with $\text{Ran}(\Pi) \subset \mathcal{D}(A)$ and $\Gamma \in \mathcal{L}(\mathbb{R}^k, U)$ satisfying the "regulator equations,"*

$$\Pi S = A\Pi + B\Gamma + P, \tag{1.16}$$

$$C\Pi = Q. \tag{1.17}$$

In this case a feedback law solving the state feedback regulator problem is given by $u(t) = Kz(t) + (\Gamma - K\Pi)w(t)$, where K is any exponentially stabilizing feedback for (A, B) .

THEOREM 2: Let **H1**, **H2** and **H3** hold. The linear error feedback regulator problem is solvable if and only if there exist mappings $\Pi \in \mathcal{L}(\mathbb{R}^k, Z)$ and $\Gamma \in \mathcal{L}(\mathbb{R}^k, U)$ with $\text{Ran}(\Pi) \subset \mathcal{D}(A)$, such that

$$\Pi S = A\Pi + B\Gamma + P \quad (1.18)$$

$$C\Pi = Q. \quad (1.19)$$

With this Π and Γ a controller solving the error feedback regulator problem is given by

$$\dot{X}(t) = FX(t) + Ge(t),$$

$$u(t) = HX(t).$$

where $X \in \mathfrak{X} = Z \times \mathbb{R}^k$,

$$G = \begin{bmatrix} G_1 \\ G_2 \end{bmatrix}, \quad H = [K \quad (\Gamma - K\Pi)],$$

$$F = \begin{bmatrix} F_{11} & F_{12} \\ F_{21} & F_{22} \end{bmatrix},$$

where

$$\begin{aligned} F_{11} &= (A + BK - G_1C), \\ F_{12} &= (P + B(\Gamma - K\Pi) + G_1Q), \\ F_{21} &= -G_2C, \\ F_{22} &= (S + G_2Q) \end{aligned}$$

and $K \in \mathcal{L}(Z, U)$ is an exponentially stabilizing feedback for the pair (A, B) and $\begin{bmatrix} G_1 \\ G_2 \end{bmatrix}$ is an exponentially stabilizing output injection (such K and G exist by **H2** and **H3**).

Solvability Criteria

We have the following solvability conditions for the regulator equations for SISO systems which relates solvability to the transmission zeros of the system (cf. [101]).

THEOREM 3: For a SISO system, if the exo-system is neutrally stable, the regulator equations are solvable if and only if the nonresonance condition

$$g(\lambda) \neq 0 \quad \text{for all} \quad \lambda \in \sigma(S)$$

is satisfied. Here

$$g(s) = C(sI - A)^{-1}B$$

is the transfer function of the plant. That is, if and only if, the eigenvalues of S are not poles or transmission zeros of the plant.

As a simple example of this result, let us return to our controlled heat equation for which the transfer function can be written as

$$g(s) = c(sI - A)^{-1}b, \quad s \in \mathbb{C}.$$

In our specific numerical example

$$g(s) = \frac{2 \sinh(\sqrt{s}/2)}{s\sqrt{s} \cosh(\sqrt{s}/2)}.$$

More generally, defining the operators

$$R_1 = A(A^2 + \alpha^2)^{-1},$$

$$R_2 = \alpha(A^2 + \alpha^2)^{-1},$$

we can explicitly express the solutions Π_1 , Π_2 , γ_1 and γ_2 of the regulator equations in (1.7) as

$$\gamma_1 = -\frac{\operatorname{Re} g(i\alpha)}{|g(i\alpha)|^2},$$

$$\gamma_2 = \frac{\operatorname{Im} g(i\alpha)}{|g(i\alpha)|^2},$$

and

$$\Pi_1 = \frac{\operatorname{Re} g(i\alpha)}{|g(i\alpha)|^2} R_1 b - \frac{\operatorname{Im} g(i\alpha)}{|g(i\alpha)|^2} R_2 b,$$

$$\Pi_2 = \frac{\operatorname{Re} g(i\alpha)}{|g(i\alpha)|^2} R_2 b + \frac{\operatorname{Im} g(i\alpha)}{|g(i\alpha)|^2} R_1 b.$$

For $\alpha \neq 0$ the conditions of Theorem 3 are satisfied and all the expressions make sense.

2 References

References

- [1] J.S.A.Hepburn, W.M.Wonham, "Error feedback and internal model on differentiable manifolds," *IEEE Trans. Autom. Control*, **AC- 29**: 397-403, 1984.
- [2] J.S.A.Hepburn, W.M.Wonham, "Structurally stable nonlinear regulation with step inputs," *Math. Systems Theory*, **17**: 319-333, 1984.
- [3] M.Fliess, "Finite dimensional observation spaces for nonlinear systems," in *Feedback control of linear and nonlinear systems* (D.Hinrichsen and A.Isidori, eds.): 73-77, Springer Verlag, 1982.

- [4] M.Fliess, I.Kupca, "A finiteness criterion for nonlinear input output differential systems," *SIAM J. Contr. Optimiz.*, **21**: 721-728, 1983.
- [5] R.W. Brockett, *Finite dimensional linear systems*, Wiley, 1970.
- [6] R.A. Adomaitas, "Analysis of turbocompressor flow instabilities," 1994 SIAM Annual Meeting, San Diego, CA, (July 1994), to appear.
- [7] R.A. Adomaitas, and E.H. Abed, "Local nonlinear control of stall inception in axial flow compressors," *AIAA Paper*, 93-2230 (1993).
- [8] R.A. Adomaitas, and E.H. Abed, "Local nonlinear control of stall in axial flow compressors," *AIAA J. Propulsion and Power*, (1994), to appear.
- [9] D.F. Fuglsang, and A.B. Cain, "Evaluation of shear layer cavity resonance mechanisms by numerical simulation," AIAA-92-0555, Reno, NV, Jan., 1992.
- [10] C.I. Byrnes and A. Isidori, "Asymptotic Stabilization of Minimum Phase Nonlinear Systems," *IEEE Trans. Aut. Control*, **36** (1991) 1122-1137.
- [11] C.I. Byrnes, A. Isidori and J.C. Willems, "Passivity, Feedback Equivalence and the Global Stabilization of Minimum Phase Nonlinear Systems," *IEEE Trans. Aut. Control*, **36** (1991) 1228-1240.
- [12] A.Isidori, C.I.Byrnes, "Output regulation of nonlinear systems," *IEEE Trans. Autom. Control*, **AC-35**: 131-140, 1990.
- [13] G. Zames, "Feedback and optimal sensitivity: model reference transformations, multiplicative seminorms and approximate inverses," *IEEE Trans. Autom. Control*, **AC-26**:301-320, 1981.
- [14] B.A.Francis, *A Course in H_∞ Control Theory*, Springer Verlag, 1987.
- [15] J.C. Doyle, K. Glover, P.P. Khargonekar, and B.A. Francis, "State space solutions to standard H_2 and H_∞ control problems," *IEEE Trans. Autom. Control*, **AC-34**:831-846, 1989.
- [16] G. Tadmor, "Worst case design in time domain," *Math. Control, Signals and Systems*, **3**:301-324, 1990.
- [17] T. Basar and P. Bernhard, *H_∞ -optimal control and related Minimax problems*, Birkhauser, 1990.
- [18] J.A. Ball and J.W. Helton, " H_∞ control for nonlinear plants: connection with differential games," In *Proc. of 28th Conf. Decision and Control*, pages 956-962, Tampa, FL, December 1989.
- [19] A.J. Van der Schaft, "A state-space approach to nonlinear H_∞ control," *Syst. and Contr. Lett.*, **16**:1-8, 1991.

- [20] A.J. Van der Schaft, "Complements to nonlinear H_∞ optimal control by state feedback," *IMA J. Math. Contr. Inf.*, 9:245-254, 1992.
- [21] A.J. Van der Schaft, " L_2 -gain analysis of nonlinear systems and nonlinear H_∞ control," Tech. Memorandum 969, Universiteit Twente, May 1991.
- [22] A. Isidori and A. Astolfi, "Nonlinear H_∞ control via measurement feedback," *J. Math. Systems, Estimation and Control*, 2:31-44, 1992.
- [23] A. Isidori and A. Astolfi, "Disturbance attenuation and H_∞ control via measurement feedback in nonlinear systems," *IEEE Trans. Autom. Control*, AC-37:1283-1293, 1992.
- [24] A. Isidori and A. Astolfi, "Nonlinear H_∞ control via measurement feedback for affine nonlinear systems," *Int J. Robust and Nonlinear Control*, 4 (1994), pp. 553-574.
- [25] B.D. Anderson, "An algebraic solution to the spectral factorization problem," *IEEE Trans. Autom. Control*, AC-12:410-414, 1967.
- [26] P.J. Moylan, "Implications of passivity in a class of nonlinear systems," *IEEE Trans. Autom. Control*, AC-19:373-381, 1974.
- [27] D. Hill and P.J. Moylan, "The stability of nonlinear dissipative systems," *IEEE Trans. Autom. Control*, AC-21:708-711, 1976.
- [28] J.C. Willems, "Dissipative dynamical systems Parts I: systems with quadratic supply rates," *Arch. Rat. Mech. Anal.*, Vol. 45, (1972), 321-351, (1972).
- [29] J.C. Willems, "Least square optimal control and the algebraic Riccati equation," *IEEE Trans. Autom. Control*, AC-16:621-634, 1971.
- [30] Keefe, L., "Multiple solutions: A barrier to flow control?," Forty-Fourth Annual Meeting of the Division of Fluid Dynamics of the American Physical Society, Scottsdale, AZ, Nov., 1991.
- [31] W. Lin, "Feedback design for nonlinear discrete-time control systems," Ph.D. Thesis at Washington University, St.Louis, (1993).
- [32] C.I. Byrnes and A. Isidori, "On the Attitude Stabilization of Rigid Spacecraft," *Automatica*, 27 (1991) 87-95.
- [33] C.I. Byrnes, A. Isidori, S. Sastry, and P. Kokotovic, "Singularly Perturbed Zero Dynamics of Nonlinear Systems," *IEEE Trans. Aut. Control*, 36, 1991.
- [34] C.I. Byrnes and J. Roltgen, "G-Field control of nonlinear systems," *Proceedings of AIAA Conference on Guidance and Control*, Hilton Head, (1992).
- [35] C.I. Byrnes and C.F. Martin, "An Integral Invariance Principle for Nonlinear Systems," to appear in *IEEE Trans. Aut. Control*.

- [36] C.I. Byrnes and S.V. Pandian, "Exponential observer design," to appear in *Proceedings of Second IFAC NOLCOS*, Bordeaux, 1992.
- [37] C.I. Byrnes and A. Isidori, "Asymptotic Tracking and Disturbance Rejection in Nonlinear Systems *New Trends in Systems Theory*, Birkhauser-Boston, 1991.
- [38] C.I. Byrnes and A. Isidori, "Asymptotic Tracking and Disturbance Rejection in Nonlinear Systems *New Trends in Systems Theory*, Birkhäuser-Boston, 1991.
- [39] F. Delli Priscoli, A. Isidori, "Robust tracking for a class of nonlinear systems," *Proc. 1st European Control Conf.* Grenoble, (1991).
- [40] A. Isidori, "Feedback control of nonlinear systems," *Proc. 1st European Control Conf.*, Grenoble, (1991).
- [41] A. Isidori, "Disturbance attenuation for nonlinear systems," to appear in *Math. Systems, Estimation, and Control*.
- [42] A. Isidori, "A Necessary Condition for Nonlinear H_∞ Control via Measurement Feedback," *Systems and Control Lett.*, 23 (1994), pp. 169-177.
- [43] C.I. Byrnes, "New methods for nonlinear optimal control," *Proceedings of First European Control Conf.*, Grenoble 1991.
- [44] C.I. Byrnes, "Some partial differential equations arising in nonlinear control and optimization," *Computation and Control, II*, Birkhäuser-Boston, (1991).
- [45] C.I. Byrnes, "Riccati partial differential equations for nonlinear Lagrange and Bolza problems," submitted to *Math. Systems, Estimation, and Control*.
- [46] C.I. Byrnes and H. Frankowska, "Unicité des contrôles optimaux et chocs pour les équations Hamilton-Jacobi-Bellman et Riccati," submitted to *Comptes Rendus Acad. Sci. Paris*.
- [47] C.I. Byrnes and A. Jhemi, "Shock Waves for Riccati Partial Differential Equations Arising in Nonlinear Optimal Control," *Systems, Models and Feedback: Theory and Applications* (A. Isidori, T.J. Tarn, eds.) Birkhäuser-Boston, 1992.
- [48] C.I. Byrnes and H. Frankowska, "Uniqueness of optimal controls and the nonexistence of shocks for Hamilton-Jacobi-Bellman and Riccati partial differential equations," submitted to *SIAM Journ. Control and Opt.*
- [49] C.I. Byrnes and K. Doll, "On the Kalman-Yacubovitch-Popov Lemma for Nonlinear Systems," *Computation and Control III*, Birkhäuser-Boston, 1993.
- [50] C.I. Byrnes and W. Lin, "Feedback stabilization of discrete time nonlinear systems," to appear in *Systems and Control Letters*.

- [51] C.I. Byrnes and W. Lin, "Lossless nonlinear systems, stability and feedback equivalence in discrete time," in preparation.
- [52] C.I. Byrnes and W. Lin, "Discrete-time lossless systems, feedback equivalence and passivity," *32nd IEEE Conf. Dec. and Control*, San Antonio, TX, 2, 1775-1781, December, 1993.
- [53] C.I. Byrnes and W. Lin, "On Discrete-Time Nonlinear Control," *32nd IEEE Conf. Dec. and Control*, San Antonio, TX, 2, 2990-2996, December, 1993.
- [54] C.I. Byrnes and W. Lin, "Passivity and Absolute Stability for a Class of Discrete-time Nonlinear Control Systems," *Automatica*, Vol.31, No.3, March, 1995.
- [55] C.I. Byrnes and W. Lin, "Design of discrete time nonlinear control systems via smooth feedback," to appear in *IEEE Trans. Aut. Cont.*
- [56] W. Lin and C.I. Byrnes, " H^∞ control of discrete time nonlinear systems via state and full information feedback," submitted to *IEEE Trans. Aut. Cont.*
- [57] A. Isidori, "New Results on Nonlinear H_∞ Control via Measurement Feedback," *Advances in Dynamic Games and Applications*, Birkhauser-Boston. 56-69, 1994.
- [58] A. Isidori, and T.J. Tarn, "Dissipation Inequalities for a Class of Composite Systems, with Applications to Constrained Disturbance Attenuation" *Proc. of 32nd IEEE Conf. Decision and Control*, 2, 1542-1547, December 1993.
- [59] S. Suzuki, A. Isidori and T.J. Tarn, " H_∞ Control of Nonlinear Systems with Sampled Measurements," *1st Asian Control Conference*, 2, 41-44, July, 1994.
- [60] W. Kang, and C.I. Byrnes, "Stability, detectability and the problem of disturbance decoupling," *Systems and Networks: Mathematical Theory and Applications*, Vol. 1 Akademie Verlag, Berlin, 77, 71-84, September, 1994.
- [61] A. Isidori and W.Kang, " H_∞ Control via Measurement Feedback for General Nonlinear Systems," *IEEE Trans. on Automatic Control*, scheduled to appear in the April 1995 issue.
- [62] W. Kang, "Approximate Linearization of Nonlinear Control Systems," *Systems and Control Letters* 23, No. 1, 43-52, 1994.
- [63] "Nonlinear H_∞ control and its application to rigid spacecraft," to appear in *IEEE Trans. Automat. Contr.*
- [64] "Extended controller form and invariants of nonlinear control systems with a single input," *J. of Mathematical System, Estimation and Control*, vol. 4, No. 2, 1994, pp253-256.

- [65] A.V. Babin, I.M. Vishik "Attractors of partial differential equations in an unbounded domain," *Proceedings of the Royal Society of Edinburgh*, 116A (1990) 221-243.
- [66] J.A. Burns and S. Kang, "A control problem for Burgers' equation with bounded input/output," *Nonlinear Dynamics*, (1991), Vol. 2, 235-262.
- [67] H.-O. Kreiss and J. Lorenz, "Initial-Boundary Value Problems and the Navier-Stokes Equations," Academic Press, 1989.
- [68] J.A. Burns and S. Kang, "A Stabilization problem for Burgers' equation with unbounded control and observation," *International Series of Numerical Mathematics*, (1991), Vol. 100, 51-72.
- [69] Mueller, T.J. and Batill, S.M., "Experimental studies of separation on a 2-dimensional air foil at low Reynolds numbers," *AIAA Journal*, Vol. 20, April, 1982, p. 457.
- [70] Constantin, P. Foias, C. Temam, R. "Attractors representing turbulent flows," *Memoirs of A.M.S.* 53 (1985) No. 314.
- [71] C. Foias, R. Temam, "Some analytic and geometric properties of the solutions of the Navier-Stokes equations," *J. Math. Pures Appl.* 58 (1979) 339-368.
- [72] Shubov, V. "Long time behavior of infinite dimensional dissipative dynamical systems," *Journal of Math. Systems, Estimation and Control*, 2 (1992), 381-427.
- [73] Ladyzhenskaya, O.A. *The Mathematical Theory of Viscous Incompressible flow*, 2nd ed. Gordon and Breach, New York, 1969.
- [74] Ladyzhenskaya, O.A. "The dynamical system that is generated by the Navier-Stokes equations," *Journal of Soviet Mathematics*, 3 (1975) 458-479.
- [75] Ladyzhenskaya, O.A., Solonnikov, V.A., Ural'ceva, N.N. *Linear and Quasilinear Equations of Parabolic Type*, Translations of AMS, Vol. 23, 1968.
- [76] C.A.J. Fletcher, "Burgers' Equation: A Model for all Reasons," *Numerical Solutions of Partial Differential Equations*, J. Noye (Editor), North-Holland Publ. Co. (1982).
- [77] H. Bateman, "Some recent researches on the motion of fluids," *Mon. Weather Rev.* Vol. 43, 163-170, (1915).
- [78] J. Burgers, "Application of a model system to illustrate some points of the statistical theory of free turbulence," *Nederl. Akad. Wefensh. Proc.*, 43 (1940), 2-12.
- [79] M.J. Lighthill, "Viscosity effects in sound waves of finite amplitude," *Surveys in Mechanics*, (eds. G.K. Batchlor and R.M. Davies), C.U.P., Cambridge, 250-351, (1956).
- [80] E. Hopf, "The partial differential equation $u_t + uu_x = \mu u_{xx}$," *Comm. Pure Appl. Math.*, 3 (1950), 201-230.

- [81] Temam, R. *Navier-Stokes Equations, Theory and Numerical Analysis*, 3rd rev. ed., North-Holland, Amsterdam, 1984.
- [82] J. He, "A root locus design methodology for parabolic distributed parameter systems," Ph.D. Thesis at Texas Tech University, (1993).
- [83] C.I. Byrnes, D.S. Gilliam and V.I. Shubov, "On the Global Dynamics of a Controlled Viscous Burgers' Equation" *Journal of Dynamical and Control Systems* to appear.
- [84] C.I. Byrnes, D.S. Gilliam, "Boundary feedback design for nonlinear distributed parameter systems," *Proc. of IEEE Conf. on Dec. and Control*, Britton, England 1991.
- [85] C.I. Byrnes and D.S. Gilliam, "Stability of certain distributed parameter systems by low dimensional controllers: a root locus approach," *Proceedings 29th IEEE International Conference on Decision and Control*.
- [86] C.I. Byrnes, D.S. Gilliam, "Boundary Feedback Stabilization of a Controlled Viscous Burgers' Equation," *Proc. of IEEE Conf. on Dec. and Control*, Tucson, AZ, 1992.
- [87] C.I. Byrnes, D.S. Gilliam and V.I. Shubov, "Boundary control, for a viscous burgers' equation," *Identification and control in systems governed by partial differential equations* H.T. Banks, R.H. Fabiano and K. Ito (Eds.), SIAM, 1993, 171-185.
- [88] C.I. Byrnes, D.S. Gilliam and V.I. Shubov, "Boundary control, feedback stabilization and the existence of attractors for a viscous burgers' equation," Preprint Texas Tech University.
- [89] C.I. Byrnes, D.S. Gilliam and V.I. Shubov, "High gain limits of trajectories and attractors for a boundary controlled viscous Burgers' equation," *J. Math. Sys., Est. and Control*
- [90] C.I. Byrnes, D.S. Gilliam and V.I. Shubov, "Convergence of trajectories for a controlled viscous Burgers' equation," *Control and Estimation of Distributed Parameter Systems: Nonlinear Phenomena* Birkhauser-Boston, 1994.
- [91] C.I. Byrnes, D.S. Gilliam, N. Okasha and V.I. Shubov, "High gain limit for boundary controlled convective reaction diffusion equations," *Proceedings 34th IEEE Conference on Decision and Control*, December 1995.
- [92] A. Balogh, D.S. Gilliam and V.I. Shubov, "Stationary solutions for a boundary controlled viscous Burgers' equation," submitted to *Journal of Mathematical Systems, Estimation and Control*.
- [93] C.I. Byrnes, D.S. Gilliam and J. He, "Root locus and boundary feedback design for a class of distributed parameter systems," *SIAM J. Control and Opt.* 32, No. 5, 1364-1427, September, 1994.

- [94] C.I. Byrnes, D.S. Gilliam and J. He, "A Root Locus Methodology for Parabolic Distributed Parameter Feedback Systems," *Computation and Control II*, Birkhäuser-Boston, 1991, 63-83.
- [95] C.I. Byrnes, D.S. Gilliam and V.I. Shubov, "Zero and pole dynamics for a controlled Burger's equation," *Proceedings 33rd IEEE CDC*, Orlando Florida, December, 1994.
- [96] C.I. Byrnes, D.S. Gilliam and V.I. Shubov, "Global Lyapunov stabilization of a nonlinear distributed parameter system," *Proceedings 33rd IEEE CDC*, Orlando Florida, December, 1994.
- [97] C.I. Byrnes and D.S. Gilliam, "Boundary stabilization and attractors for a controlled Burgers' equation," *Proceedings Third Conference on Computation and Control*, 1993, Birkhäuser, Boston,
- [98] D.S. Gilliam, D. Lee, C.F. Martin and V.I. Shubov, "Turbulent Behavior for a Boundary Controlled Burger's equation," *Proceedings 33rd IEEE CDC*, Orlando Florida, December, 1994.
- [99] C.I. Byrnes, D.S. Gilliam, V.I. Shubov and Z. Xu, "The effect of viscosity on the steady state response of a nonlinear system," *Proceedings Fourth Conference on Computation and Control* Bozeman, Montana, August, 1994.
- [100] H.T. Banks, D.S. Gilliam, and V.I. Shubov, "Well-posedness for a one dimensional nonlinear beam," *Proceedings Fourth Conference on Computation and Control* Bozeman, Montana, August, 1994.
- [101] C.I. Byrnes, D.S. Gilliam, I.G. Laukó, V.I. Shubov, "Harmonic forcing for linear distributed parameter systems," to appear in *Journal of Mathematical Systems, Estimation and Control*.
- [102] C.I. Byrnes, D.S. Gilliam, I.G. Laukó, V.I. Shubov, "The output feedback regulatory problem for linear distributed parameter systems," preprint 1997.
- [103] R. F. Curtain and H. J. Zwart, "An Introduction to Infinite-Dimensional Linear Systems," Springer-Verlag, 1995.
- [104] B.A. Francis, "The linear multivariable regulator problem," *SIAM J. Contr. Optimiz.*, 15:486-505, 1977.
- [105] B.A. Francis and W.M. Wonham, "The internal model principle for linear multivariable regulators," *J. Appl. Math. Optimiz.* 2 (1975), 170-194.
- [106] M. Hautus, "Linear Matrix equations with Applications to the Regulator Problem," in *Outils et Modeles Mathematique pour l'Automatique*, I. D. Landau, Ed. Paris: C.R.N.S., (1983), 399-412.
- [107] C.I. Byrnes, A. Isidori, F. Delli Priscoli, "Output Regulation for Uncertain Nonlinear Systems," Birkhäuser, 1997.

3 Participating Professionals

1. Principal Investigators

- Christopher I. Byrnes
- Alberto Isidori

2. Senior Personnel

- David S. Gilliam

3. Postdocs

- Wei Lin
- Istvan Lauko

4. Graduate Students

- K. Doll, D.Sc. Washington University, anticipated 1994
Defense: December, 1995.
Thesis Title: Robust Stabilization of Nonlinear Systems
- R. Eberhardt, D.Sc. Washington University,
Defense: December, 1995.
Thesis Title: Nonlinear Optimal Control with Input Constraints

4 Scientific Publications

a. *Peer Reviewed Journal:*

Name of Journal: SIAM Journal of Control and Optimization

Title of Article: "Uniqueness of optimal trajectories and the non-existence of shocks for Hamilton-Jacobi-Bellman and Riccati partial differential equations"

Author(s): C.I. Byrnes and H. Frankowska

Publisher: SIAM

Volume: Page(s): xxx-xxx, Month Submitted: May

Year Submitted: 1995

Name of Journal: Automatica

Title of Article: "Passivity and Absolute Stabilization of a Class of Discrete-Time Nonlinear Systems"

Author: W. Lin and C.I. Byrnes

Publisher: Elsevier Science Ltd

Volume: 31, Page: 263-268, Year Published: 1995.

Name of Journal: Automatica
Title of Article: "Zero-State Observability and Stability of Discrete-Time Nonlinear Systems"
Author: W. Lin and C.I. Byrnes
Publisher: Elsevier Science Ltd
Volume: 31, Page: 269-274, Year Published: 1995.

Name of Journal: Automatica
Title of Article: "Discrete-Time Nonlinear H-infinity Control with Measurement Feedback"
Author: W. Lin and C.I. Byrnes
Publisher: Elsevier Science Ltd
Volume: 31, Page: 419-434, Year Published: 1995.

Name of Journal: Systems and Control Letters
Title of Article: "Remarks on Linearization of Discrete-Time Autonomous Systems and Nonlinear Observer Design"
Author: W. Lin and C.I. Byrnes
Publisher: Elsevier Science BV
Volume: 25, Page: 31-40, Year Published: 1995.

Name of Journal: IEEE Trans. Automat. Contr.
Title of Article: "H-infinity Control of Discrete-Time Nonlinear Systems"
Author: W. Lin and C.I. Byrnes
Publisher: IEEE
Volume: 41, Page: 494-510, Year Published: 1996.

Name of Journal: Journal of Mathematical Systems, Estimation and Control
Title of Article: "H-infinity Control of Nonlinear Systems with Sampled Measurements"
Author(s): S.Suzuki, A.Isidori and T.J.Tarn
Publisher: Birkhauser
Volume: 5, Page(s): 259-262,
Month Published: March, Year Published: 1995

Name of Journal: IEEE Transactions on Automatic Control
Title of Article: "H-infinity control of discrete time nonlinear control systems via state and full information feedback"
Author: C.I.Byrnes and W. Lin
Publisher: IEEE Volume: , Page:
Year Published: 1996 (to appear).

Name of Journal: Journal of Mathematical Systems, Estimation and Control
Title of Article: "Solution of Nonlinear Lagrange and Bolza problems via Riccati par-

tial differential equations”
Author: C.I.Byrnes
Publisher: , Page: , Year Published: .

Name of Journal: IEEE Transactions on Automatic Control
Title of Article: “Robust regulation for nonlinear systems with gain-bounded uncertainties”
Author: A.Isidori and T.J.Tarn
Publisher: IEEE
Volume: 40, Page: 1744-1754, Year Published: 1995.

Name of Journal: Automatica
Title of Article: “Structurally Stable Output Regulation of Nonlinear Systems”
Author: C.I.Byrnes, F. Delli Priscoli, A. Isidori and W.Kang
Publisher: Pergamon Press
Volume: no. 3, Page:369–385, Year Published: 1997.

Name of Journal: IEEE Control Systems Magazine
Title of Article: “Force regulation and contact transition control”
Author: T.J.Tarn, Y. Wu, N.Xi and A.Isidori
Publisher: IEEE
Volume: 16, Page: 32-40, Year Published: 1996.

Name of Journal: Systems and Control Letters
Title of Article: “A note on almost disturbance decoupling for nonlinear minimum phase systems”
Author: A.Isidori
Publisher: Elsevier Science BV Volume: 27, Page: 191-194,
Year Published: 1996.

Name of Journal: IEEE Trans. Automat. Contr.
Title of Article: “H-infinity Control of Discrete-Time Nonlinear Systems”
Author: W. Lin and C. I. Byrnes
Publisher: IEEE
Volume: 40, Page: 494-510, Year Published: 1996.

Name of Journal: Automatica
Title of Article: “Global Asymptotic Stabilization of General Nonlinear Systems with Stable Free Dynamics via Passivity and Bounded Feedback”
Author: W. Lin
Publisher: Pergamon Press
Volume: 32, Page: 915-924, Year Published: 1996.

Name of Journal: International Journal of Control
Title of Article: "Mixed H₂/H-infinity Control via State Feedback for Nonlinear Systems"
Author: W. Lin
Publisher: Taylor & Francis Ltd
Volume: -, Page: -, Year Published: 1996.

Name of Journal: Systems and Control Letters
Title of Article: "Further results on Global Stabilization of Discrete Nonlinear Systems"
Author: W. Lin
Publisher: Elsevier Science BV
Volume: 28, Page: -, Year Published: 1996.

Name of Journal: Differential and Integral Equations
Title of Article: "Global Solvability for Damped Abstract Nonlinear Hyperbolic Systems"
Author: H.T. Banks, D.S. Gilliam, V.I. Shubov
Publisher:
Volume: 10 no. 2, Page: 309-332, Year Published: 1997.

Name of Journal: Journal of Mathematical Systems, Estimation and Control
Title of Article: "High Gain Limits of Trajectories and Attractors for a Boundary Controlled Viscous Burgers' Equation"
Author: C.I. Byrnes, D.S. Gilliam, V.I. Shubov
Publisher:
Volume: , Page: , Year Published: 1996

Name of Journal: Journal of Dynamical and Control Systems
Title of Article: "On the Global Dynamics of a Controlled Viscous Burgers' Equation"
Author: C.I. Byrnes, D.S. Gilliam, V.I. Shubov
Publisher:
Volume: , Page: , Year Published: 1996.

Name of Journal: Automatica
Title of Article: "Structurally stable output regulation of nonlinear systems"
Author: C.I. Byrnes, F. Delli Priscoli, A. Isidori, W. Kang
Publisher: Elsevier Science BV
Volume: 33
Page: 369-385
Year Published: 1997.

Name of Journal: IEEE Trans. on Automatic Control

Title of Article: "A remark on the problem of semiglobal nonlinear output regulation"
Author: A. Isidori
Publisher: IEEE Press
Volume: 43
Page: to appear
Year Published: 1997.

Name of Journal: IEEE Trans. on Automatic Control
Title of Article: "On the partial stochastic realization problem"
Author: C.I. Byrnes and A. Lindquist
Publisher: IEEE Press
Volume: 42, No. 8
Page: 1049 - 1070
Year Published: 1997.

Name of Journal: SIAM J. Cont. and Opt.
Title of Article: "A convex optimization approach to the rational covariance extension problem"
Author: C.I. Byrnes, S.V. Gusev, and A. Lindquist
Publisher: SIAM Press
Status: Submitted

Name of Journal: *Journal of Mathematical Systems, Estimation and Control*
Title of Article: "Stationary solutions for a boundary controlled viscous Burgers' equation"
Author: A. Balogh, D.S. Gilliam and V.I. Shubov
Status: Submitted

Name of Journal: *Journal of Mathematical Systems, Estimation and Control*
Title of Article: "Numerical stationary solutions for a viscous Burgers' equation"
Author: A. Balogh, J.A. Burns, D.S. Gilliam and V.I. Shubov
Publisher: Birkhäuser
Accepted: December 1996.

Name of Journal: *Journal of Mathematical Systems, Estimation and Control*
Title of Article: "Harmonic forcing for linear distributed parameter systems"
Author: C.I. Byrnes, D.S. Gilliam, I. Lauko and V.I. Shubov
Publisher: Birkhäuser
Accepted: December 1996.

Name of Journal: *Journal of Mathematical Systems, Estimation and Control*
Title of Article: "On the Riccati Partial Differential Equation for Nonlinear Bolza and Lagrange Problems"

Author: C.I. Byrnes
Publisher: Birkhäuser
Accepted: May 1997.

b. *Peer Reviewed Conference Proceedings:*

Name of Conference: IEEE Conference on Decision and Control
Title of Article: "High Gain Limit for Boundary Controlled Convective Reaction Diffusion Equations"
Author: C.I. Byrnes, D.S. Gilliam, N. Okasha, V.I. Shubov
Publisher: IEEE
Volume: 34th CDC, Page: , Year Published: 1995.

Name of Conference: IEEE Conference on Decision and Control
Title of Article: "Well-Posedness for Controlled Nonlinear Damped Membranes with Fixed Boundary"
Author: H.T. Banks, D.S. Gilliam, V.I. Shubov
Publisher: IEEE
Volume: 34th CDC, Page: , Year Published: 1995.

Name of Conference: IEEE Conference on Decision and Control
Title of Article: "Global Robust Stabilization of Minimum-Phase Nonlinear Systems"
Author: W. Lin
Publisher: IEEE
Volume: 34th CDC, Page: 521-526, Year Published: 1995.

Name of Conference: IEEE Conference on Decision and Control
Title of Article: "Global Stabilization of Discrete Non-Affine Systems"
Author: W. Lin
Publisher: IEEE
Volume: 34th CDC, Page: 510-511, Year Published: 1995.

Name of Conference: IEEE Conference on Decision and Control
Title of Article: "Mixed H_2/H -infinity Control of Nonlinear Systems"
Author: W. Lin
Publisher: IEEE
Volume: 34th CDC, Page: 333-338, Year Published: 1995.

Name of Conference: 13th IFAC World Congress
Title of Article: "Passivity, Bounded State Feedback and Global Stabilization of Non-linear Systems"
Author: W. Lin
Publisher: Elsevier
Volume: E, Page: 103-108, Year Published: 1996.

Name of Conference: 13th IFAC World Congress
Title of Article: "Solutions to the Output Regulation Problem of Linear Singular Systems"
Author: W. Lin and L. Dai
Publisher: Elsevier
Volume: D, Page: 97-102, Year Published: 1996.

Name of Conference: 1995 American Control Conference
Title of Article: "Some New Results on Stability and Observability of Discrete-time Autonomous Systems"
Author(s): W. Lin and C.I. Byrnes
Publisher: IEEE
Volume: 6, Page(s): 4214-4218, Month Published: June,
Year Published:1995

Name of Conference: IFAC Nonlinear Control Systems Symposium
Title of Article: "On the Dynamics of Boundary Controlled Nonlinear Distributed Parameter Systems"
Author(s): C.I. Byrnes, D.S. Gilliam and Victor I. Shubov Publisher: Pergamon
Volume: 62 Page(s): 913-913, Month Published: June,
Year Published:1995

Name of Conference: 34th IEEE Conference on Decision and Control
Title of Article: "Well-Posedness for Controlled Nonlinear Damped Membranes with Fixed Boundary "
Author(s): H.T. Banks, D.S. Gilliam and Victor I. Shubov
Publisher: IEEE
Volume: Page(s): , Month Published: December,
Year Published:1995

Name of Conference: 35rd IEEE Conf. Decision and Control (Kobe, Japan, December 1996)
Title of Article: "Global normal forms for MIMO nonlinear systems, with application to stabilization and disturbance attenuation"
Author: B.Schwartz, A. Isidori and T.J. Tarn
Page: 1041-1046
Year Published: 1996.

Name of Conference: 35rd IEEE Conf. Decision and Control (Kobe, Japan, December 1996)
Title of Article: " L_2 disturbance attenuation and performance bounds for linear non-minimum phase square invertible systems"

Author: B.Schwartz, A. Isidori and T.J. Tarn
Page: 227-228
Year Published: 1996.

Name of Conference: 4th European Control Conference (Brussels, Belgium, July 1997)
Title of Article: "Performance bounds for disturbance attenuation in nonlinear non-minimum-phase systems"
Author: B.Schwartz, A. Isidori and T.J. Tarn
Page: to appear
Year Published: 1997.

Name of Conference: 36th IEEE Conf. Decision and Control (San Diego, CA, December 1997)
Title of Article: "Theoretical and numerical results for parameter estimation in nonlinear elastomers"
Author: H.T. Banks, D.S. Gilliam and G. Pinter
Page: 3733-3738.
Year Published: 1997

Name of Conference: 36th IEEE Conf. Decision and Control (San Diego, CA, December 1997)
Title of Article: "Output Regulation for Parabolic Distributed Parameter Systems: Set Point Control"
Author: C.I. Byrnes, D.S. Gilliam, I. Laukó and V.I. Shubov
Page: 2231-2236
Year Published: 1997

Name of Conference: 36th IEEE Conf. Decision and Control (San Diego, CA, December 1997)
Title of Article: "Some Recent Results on Feedback Regularization of Navier-Stokes Equations"
Author: A. Balogh, D.S. Gilliam, and V.I. Shubov
Page: 2231-2236
Year Published: 1997

Name of Conference: 36th IEEE Conf. Decision and Control (San Diego, CA, December 1997)
Title of Article: "Global L_2 -gain State Feedback Design for a Class of Nonlinear Systems"
Author: A.Isidori and W.Lin
Page: 2831-2836
Year Published: 1997

Name of Conference: 28th AIAA Fluid Dynamics Conference/ 4th AIAA Shear Flow Control Conference, Snowmass Village, CO
Title of Article: "Example of output regulation for distributed parameter systems"
Author: C.I. Byrnes, D.S. Gilliam, A. Isidori, I. Laukó, and V.I. Shubov
Year Published: 1997.

Books:

Title of Book: "Output Regulation of Uncertain Nonlinear Systems"
Author of Book: C.I. Byrnes, F. Delli Priscoli, A. Isidori Publisher: Birkhäuser (Boston)
Pages: 1-120
Year Published: 1997.

Title of Book: "Systems and Control in the Twenty-First Century"
Editors of Book: C.I. Byrnes, B.N. Datta, D.S. Gilliam, C.F. Martin
Publisher: Birkhäuser (Boston)
Pages: 1-434
Year Published: 1997.

Book Chapters:

Title of Book: "Colloquim on Automatic Control"
Editor of Book: C. Bonivento, G. Marri, G. Zanasi
Title of Chapter: "Semiglobal robust regulation of nonlinear systems",
Author of Chapter: A. Isidori
Publisher: Springer Verlag
Pages: 31-59, Year Published: 1996.

Title of Book: "Systems and Control in the Twenty-First Century"
Editor of Book: C.I. Byrnes, B.N. Datta, D.S. Gilliam, C.F. Martin
Author of Chapter: C.I. Byrnes and A. Lindquist
Title of Chapter: "On duality between filtering and interpolation"
Pages: 101-136 Publisher: Birkhäuser (Boston)

Title of Book: "Current and Future Directions in Applied Mathematics"
Editor of Book: M. Alber, B. Hu, J. Rosenthal
Author of Chapter: C.I. Byrnes, H.J. Landau, and A. Lindquist
Title of Chapter: "On the well-posedness of the rational covariance extension problem"
Pages: 83-108
Publisher: Birkhäuser (Boston)

5 Scientific Interactions

Our principal investigating team has enjoyed collaborative research with engineering research and development personnel at the McDonnell-Douglas Aircraft Division of Boeing in St. Louis, MO, at Lockheed - Martin in Dallas, TX and scientific interaction with AFOSR personnel at Bolling AFB, Ft. Eglin AFB and Wright Patterson AFB. Our most recent contacts have been:

During the month of February, 1997, Dr. Christopher I. Byrnes presented a technical briefing on nonlinear control systems and problems in flow control for Dr. Marc Jacobs AFOSR and Dr. Charles Holland AFOSR. Other participants included Dr. Rowena Eberhardt (McDonnell Douglas Aerospace, St. Louis, MO), Dr. David E. Parekh (McDonnell Douglas Aerospace, St. Louis, MO), Dr. Kevin Wise (McDonnell Douglas Aerospace, St. Louis, MO), and Dr. David S. Gilliam, Dr. Ervin Roden, Dr. Massoud Amin, Dr. Barna Szabo, Mr. James Ramsey from Washington University.

Professors Christopher I. Byrnes and Alberto Isidori have consulted with Dr. Rowena Eberhardt (McDonnell Douglas Aerospace, St. Louis, MO) on robust output regulation of nonlinear systems. This work is aimed at extending robust output regulation methodologies to flight controller design of tailless aircraft, including the X36 and MANX aircraft.

Alberto Isidori taught a course on Nonlinear Systems and Control at the NASA Research Center in Langley, VA. Program. Part I (15 hours): nonlinear systems structure, feedback linearization, zero dynamics. Part II (15 hours): nonlinear system stabilization, regulation and tracking. Part I was taught in November 1996, Part II in February 1997.

During the month of April, 1997, Dr. David Gilliam consulted with researchers in the *Air Force Center for Optimal Design and Control* at Virginia Tech & State University concerning the design of feedback control laws for the problem of output regulation of distributed parameter systems. During this same visit Dr. Gilliam served as an advisor on questions concerning the existence of global dynamics and attractors for their work on *Thermal Convective Processes*.

We have presented many invited lectures and colloquia nationally and internationally:

September 1994

"Feedback Stabilization About Attractors and Inertial Manifolds," Invited lecture at Royal Institute of Technology, Stockholm, lecture presented by Professor C.I. Byrnes

February 1995:

"Feedback Stabilization About Attractors and Inertial Manifolds" Università di Roma - La Sapienza Presented by Professor C. I. Byrnes

April, 1995:

"Feedback Stabilization in the Large for Nonaffine Nonlinear Systems with Stable Free

Dynamics," 3rd SIAM Conference on Control and Its Applications, St.Louis, Presented by Professor Wei Lin.

June 1995:

"Nonlinear Control Systems," AFOSR Contractors Review Meeting Minneapolis-St. Paul, Presented by Professor C.I. Byrnes

"A Riccati Equation for Partial Stochastic Realization Theory" Royal Institute of Technology Stockholm, Sweden Presented by Professor C.I. Byrnes

"Some New Results on Stability and Observability of Discrete-time Autonomous Systems" American Control Conference Seattle, Presented by Professor Wei Lin.

"Feedback Stabilization of General Nonlinear Systems," IFAC Nonlinear Control Systems Symposium, Tahoe City, Presented by Professor Wei Lin.

"On the Dynamics of Boundary Controlled Nonlinear Distributed Parameter Systems" IFAC Nonlinear Control Systems Symposium, Tahoe City, Presented by Professor D. S. Gilliam

October 1995:

"Robust Regulation of Nonlinear Systems," Invited talk presented by Prof. C.I. Byrnes at VPI & State University.

"Robust Regulation of Nonlinear Systems," Plenary talk presented by Prof. C.I. Byrnes at NCSU Southeast Regional Differential Equations Conference.

"On the Dynamics of Boundary Controlled Convective Reaction Diffusion Equations," Invited talk presented by D.S. Gilliam in the minisymposium "Control and Computational Fluid Dynamics" at the 1995 SIAM Annual Meeting at Charlotte, North Carolina.

"Electromagnetic Waves Over a Three Dimensional Conducting Half Space Invited lecture presented by D.S. Gilliam in the Center For Research in Scientific Computation at North Carolina State University.

"Low-Gain Feedback Stabilization of Controllable Nonlinear Systems with Stable Free Dynamics" Invited lecture presented by Prof. Wei Lin at the Center for Control Engineering and Computation, Dept. of Electrical & Computer Engineering, University of California, Santa Barbara.

November 1995:

"Robust Regulation of Nonlinear Systems," Invited talk presented by Prof. C.I. Byrnes in the Departemnt of Electrical Engineering at the University of Hong Kong, Hong Kong.

“Output Regulation Revisited” Distinguished lectures series, Department of Electrical Engineering, IOWA State University, presented by Dr. Alberto Isidori.

“Robust Stabilization and Adaptive Regulation of Minimum-Phase Nonlinear Systems with Uncertainty” Invited lecture presented by Prof. Wei Lin at the Dept. of Electrical Engineering, Iowa State University, Ames.

December 1995:

“Disturbance Attenuation for a Class of Nonlinear Non-Minimum Phase Systems,” Invited lecture presented by Prof. Alberto Isidori at the 34th Control and Decision Conference.

“High Gain Limit for Boundary Controlled Convective Reaction Diffusion Equations” lecture presented by D.S. Gilliam at the 34th Control and Decision Conference.

“Well-Posedness for Controlled Nonlinear Damped Membranes with Fixed Boundary” lecture presented by D.S. Gilliam at the 34th Control and Decision Conference.

“Global Robust Stabilization of Minimum-Phase Nonlinear Systems” lecture presented by W.Lin at the 34th Control and Decision Conference.

“Global Stabilization of Discrete Non-Affine Systems” lecture presented by W.Lin at the 34th Control and Decision Conference.

“Mixed H_2/H -infinity Control of Nonlinear Systems” Author: W. Lin lecture presented by W.Lin at the 34th Control and Decision Conference.

January 1996:

“Dynamics of systems governed by convection reaction diffusion equations,” lecture presented at the Joint AMS/MAA Annual Meeting in Orlando, Florida.

“The Regulator Problem for Linear Distributed Parameter Systems,” Invited lecture presented by D.S. Gilliam in the Department of Systems Science and Math at Washington University in St. Louis.

March 1996:

“Complete Parameterization of Solutions to the Rational Covariance Problem,” Invited lecture presented by C.I. Byrnes at Ecole Normale Supérieure, Paris.

April 1996:

“Complete Parameterization of Solutions to the Rational Covariance Problem,” Plenary lecture presented by C.I. Byrnes at Conference on the Future Directions in Applied Mathematics at Notre Dame.

June 1996:

"Global Stabilization of Discrete-Time Nonlinear Systems via Bounded Feedback" Invited talk presented by Prof. Wei Lin at the 96 Mathematical Theory of Networks and Systems (MTNS) Conference, St. Louis, MO.

"The Structure of Attractors for a Boundary Controlled Viscous Burgers' Equation," Invited talk presented by Andras Balogh at the 96 Mathematical Theory of Networks and Systems (MTNS) Conference, St. Louis, MO.

"Recent Results on Boundary Control for a Class of Higher Dimensional Convection-Reaction Diffusion Equations," Invited talk presented by David S. Gilliam at the 96 Mathematical Theory of Networks and Systems (MTNS) Conference, St. Louis, MO.

"Nonlinear Observers for Hopf Bifurcating Systems" Invited talk presented by Dr. V. Sundarapandian at the 96 Mathematical Theory of Networks and Systems (MTNS) Conference, St. Louis, MO.

"Adaptive Control of Minimum-Phase Nonlinear Systems" presented by Prof. Wei Lin at the 96 Mathematical Theory of Networks and Systems (MTNS) Conference, St. Louis, MO.

"Robust Nonlinear Output Regulation," Invited talk presented by Prof. Alberto Isidori at the 96 Mathematical Theory of Networks and Systems (MTNS) Conference, St. Louis, MO.

"Passivity, Bounded State Feedback and Global Stabilization of Nonlinear Systems" presented by Prof. Wei Lin at the 13th IFAC World Congress.

"Solutions to the Output Regulation Problem of Linear Singular Systems," presented by Prof. Wei Lin at the 13th IFAC World Congress.

August 1996:

"On the Rational Caratheodory Extension Problem," Invited lecture presented by Prof. C.I. Byrnes at the Fifth Bozeman Conference on Computation and Control.

"The Regulator Problem for Linear Distributed Parameter Systems," Invited lecture presented by Istvan Lauko at the Fifth Bozeman Conference on Computation and Control.

"On the Dynamics and Control of a Class of Higher Dimensional Convection Reaction Diffusion Equations," Invited lecture presented by David Gilliam at the Fifth Bozeman Conference on Computation and Control.

"Numerical Stationary Solutions for Burgers' Equation with Neumann Boundary Conditions," Invited lecture presented by David Gilliam at the Fifth Bozeman Conference on Computation and Control.

"Regularization and Control of Three Dimensional Navier Stokes Equations," Invited lecture presented by Andras Balogh at the Fifth Bozeman Conference on Computation and Control.

October 1996:

"Zeros and Zero Dynamics for Linear Distributed Parameter Systems," A series of lectures given by Dr. David Gilliam in the Texas Tech University Joint Civil Engineering, Mathematics and Mechanical Engineering Seminar.

December 1996:

"Global normal forms for MIMO nonlinear systems, with application to stabilization and disturbance attenuation" Lecture presented by Dr. Alberto Isidori at the 35rd IEEE Conf. Decision and Control (Kobe, Japan).

" L_2 disturbance attenuation and performance bounds for linear non-minimum phase square invertible systems" Lecture presented by Dr. Alberto Isidori at the 35rd IEEE Conf. Decision and Control (Kobe, Japan).

"Immersion and the internal model principle: tools for robust nonlinear control" Lecture presented by Dr. Christopher I. Byrnes at the 35rd IEEE Conf. Decision and Control (Kobe, Japan).

"The rational covariance extension problem with applications to speech synthesis" Invited lecture presented by Dr. Christopher I. Byrnes at The University of Tokyo.

"Robust nonlinear control" Invited lecture presented by Dr. Christopher I. Byrnes at Dewan Riset Nasional, Serpong, Indonesia.

January 1997:

"Global L_2 -Gain State Feedback Design for a Class of Nonlinear Systems" Lecture presented by Dr. Alberto Isidori at COSY Workshop on Nonlinear Systems held at the ETH-Zurich, Switzerland.

February 1997:

"The geometry of positive real functions with applications to signal processing and to speech synthesis" Invited lecture presented by Dr. Christopher I. Byrnes at The Texas Tech University.

March 1997:

"The rational covariance extension problem with applications to speech synthesis" Invited lecture presented by Dr. Christopher I. Byrnes at Texas Tech University.

"Robust Output Regulation of Nonlinear Systems" Invited lecture presented by Dr. Alberto Isidori at the University of Aalborg, Denmark.

April 1997:

"On the Global Dynamics of a Class Boundary Controlled Hydrodynamic Systems in Higher Dimensions," Lecture presented by Dr. Victor I. Shubov at the Texas Partial Differential Equations Conference in Denton, TX.

"Harmonic forcing for linear distributed parameter systems" Invited lecture presented by István Laukó in the Texas Tech University Joint Civil Engineering, Mathematics and Mechanical Engineering Seminar.

May 1997:

"Nonlinear control systems" Invited lecture presented by Dr. Christopher I. Byrnes at the 1997 AFOSR Contractors Review Meeting, Wright Patterson AFB, Dayton, OH.

June 1997:

"On the covariance extension problem" 5th IEEE Mediterranean Conference, Paphos, Cyprus Invited lecture presented by Professor C. I. Byrnes

"Robust Output Regulation of Nonlinear Systems" Invited lecture presented by Dr. Alberto Isidori at the Imperial College, London, UK.

"Robust Nonlinear Control" Invited lecture presented by Dr. Christopher I. Byrnes at the 28th AIAA Fluid Dynamics Conference/ 4th AIAA Shear Flow Control Conference, Snowmass Village, CO

July 1997:

Dr. David S. Gilliam participated in 12th International Conference of the American Meteorological Society on Boundary Layers and Turbulence, Vancouver, BC.

"On Duality between Filtering and Interpolation" University of Tokyo, Japan Invited lecture presented by Professor Anders Lindquist.

December 1997:

"Global L_2 -gain State Feedback Design for a Class of Nonlinear Systems," 36th IEEE Conf. Decision and Control (San Diego, CA, December 1997), Lecture presented by Professor A. Isidori

"Harmonic Forcing for a Class of Nonlinear Systems," 36th IEEE Conf. Decision and Control (San Diego, CA, December 1997), Lecture presented by Professor A. Isidori

"Computational Methods for Feedback Control of Distributed Parameter Systems," Special Session at 36th IEEE Conf. Decision and Control (San Diego, CA, December 1997), Organizer and Chair Professor David Gilliam.

6 New Discoveries

One of the highlights of our research program during this reporting period has been the research, the preparation and the publication of our recent monograph describing a solution to the problem of robust output regulation for lumped nonlinear systems. Since systems containing unknown real parameters are rarely detectable or observable, when the state is augmented to include the unknown parameters, it is typically impossible to directly compute a (for example, stabilizing) feedback law as a function of the system output. A key development has been the identification of an alternative to state feedback/state observer design which is better suited for robust control. This alternative is based on a combination of the internal model principle and the notion of immersion. Using these tools, a solution of the robust output regulation problem has been obtained. One early example of an alternative to directly computing a gain from more data than is actually need to produce the gain is the so-called fast filtering algorithm for Kalman filtering. Thus, instead of computing the Kalman gain as the product of a positive solution of a Riccati equation and a state estimate, fast filtering propagates the Kalman gain as a vector, along with a covector.

Another especially important, but unanticipated, success in our research effort has begun with the development of the phase portrait for the fast filtering algorithm for scalar systems, as a nonlinear dynamical system. This phase portrait, and its relation to the geometry of spaces of positive real functions, has recently been used to solve a long standing open problem in signal processing and speech synthesis, with important implications in the digital encoding and transmission of human speech. Indeed, we have developed a geometric duality between filtering and interpolation, tying together two fundamental classes of problems, rational covariance extension and the dynamics of fast filtering algorithms. Perhaps the most important accomplishment during this particular research period has been the discovery of a convex minimization problem that leads to an effective algorithm for speech synthesis and speech analysis. These algorithms, when coded on a programmable digital signal processing chip and coupled with A/D and D/A converters, allow for the encoding and decoding, and hence the transmission, of human speech. In addition to wireless speech transmission technologies, there are also potential applications to secure communications systems. A patent for using this methodology in speech synthesis applications is pending.

Among our most significant accomplishments in our research in the area of distributed parameter systems is the development of geometric theory of output regulation for linear distributed parameter systems with bounded actuators and sensors. In particular, for a very general class of distributed parameter plants with bounded input and output operators and for reference signals and disturbances generated by finite dimensional exogenous systems, we have given necessary and sufficient conditions for solvability of the state feedback regulator problem (SFRP) and error feedback regulator problem (EFRP). These conditions are given in terms of the solvability of a pair of regulator equations which are easily solved numerically off-line. The solution of these equations provide explicit and/or numerical solutions which yield an exact and/or approximate feedback law for the SFRP or controller for solving the EFRP. These techniques have been successfully applied to problems in asymptotic tracking of harmonic reference signals and set point control for both parabolic and hyperbolic examples.

Further, for the problem of tracking a periodic motion and for plants whose state dynamics are governed discrete Riesz spectral operators we have been able to characterize solvability of the regulator equation in terms of certain nonresonance conditions related to the poles and zeros of the open loop transfer function. For systems for which the zero dynamics exists, we are also able to characterize solvability of the regulator equations in terms of the existence of an isomorphic copy of the exosystem in the composite systems zero dynamics, complimentary to the zero dynamics of the plant. Sponsored work with McDonnell Douglas Aircraft is underway to transition output regulator technologies to the problem of shaping the airflow downstream from a wing section in order to either produce more lift for tail flaps, or to better mix the jet exhaust in an effort to lower heat and infrared signals.

7 Additional Information

Our research team has been involved in the following transitions of technology. Dr. Christopher I. Byrnes and Dr. David S. Gilliam together with Dr. David Parekh (McDonnell Douglas Aerospace, St. Louis, MO) have made progress on robust nonlinear control design for problems of flow control. The intended application being the development of a robust control strategy for the control of airflow to increase lift on tail flaps on aircraft such as the C17. In May 1997, Drs. Christopher I. Byrnes and Anders G. Lindquist have submitted, through Washington University, the patent disclosure, "A new method and device for speech synthesis," to the U.S. Patent Office.