

289125

JPRS-ESA-84-030

8 August 1984

DISTRIBUTION STATEMENT A

Approved for public release;
Distribution Unlimited

East Europe Report

SCIENCE & TECHNOLOGY

19980501 107

DTIC QUALITY IMPROVED 3

FBIS

FOREIGN BROADCAST INFORMATION SERVICE

REPRODUCED BY
NATIONAL TECHNICAL
INFORMATION SERVICE
U.S. DEPARTMENT OF COMMERCE
SPRINGFIELD, VA. 22161

6
49
A03

NOTE

JPRS publications contain information primarily from foreign newspapers, periodicals and books, but also from news agency transmissions and broadcasts. Materials from foreign-language sources are translated; those from English-language sources are transcribed or reprinted, with the original phrasing and other characteristics retained.

Headlines, editorial reports, and material enclosed in brackets [] are supplied by JPRS. Processing indicators such as [Text] or [Excerpt] in the first line of each item, or following the last line of a brief, indicate how the original information was processed. Where no processing indicator is given, the information was summarized or extracted.

Unfamiliar names rendered phonetically or transliterated are enclosed in parentheses. Words or names preceded by a question mark and enclosed in parentheses were not clear in the original but have been supplied as appropriate in context. Other unattributed parenthetical notes within the body of an item originate with the source. Times within items are as given by source.

The contents of this publication in no way represent the policies, views or attitudes of the U.S. Government.

PROCUREMENT OF PUBLICATIONS

JPRS publications may be ordered from the National Technical Information Service, Springfield, Virginia 22161. In ordering, it is recommended that the JPRS number, title, date and author, if applicable, of publication be cited.

Current JPRS publications are announced in Government Reports Announcements issued semi-monthly by the National Technical Information Service, and are listed in the Monthly Catalog of U.S. Government Publications issued by the Superintendent of Documents, U.S. Government Printing Office, Washington, D.C. 20402.

Correspondence pertaining to matters other than procurement may be addressed to Joint Publications Research Service, 1000 North Glebe Road, Arlington, Virginia 22201.

NOTE

JPRS publications contain information primarily from foreign newspapers, periodicals and books, but also from news agency transmissions and broadcasts. Materials from foreign-language sources are translated; those from English-language sources are transcribed or reprinted, with the original phrasing and other characteristics retained.

Headlines, editorial reports, and material enclosed in brackets [] are supplied by JPRS. Processing indicators such as [Text] or [Excerpt] in the first line of each item, or following the last line of a brief, indicate how the original information was processed. Where no processing indicator is given, the information was summarized or extracted.

Unfamiliar names rendered phonetically or transliterated are enclosed in parentheses. Words or names preceded by a question mark and enclosed in parentheses were not clear in the original but have been supplied as appropriate in context. Other unattributed parenthetical notes within the body of an item originate with the source. Times within items are as given by source.

The contents of this publication in no way represent the policies, views or attitudes of the U.S. Government.

PROCUREMENT OF PUBLICATIONS

JPRS publications may be ordered from the National Technical Information Service, Springfield, Virginia 22161. In ordering, it is recommended that the JPRS number, title, date and author, if applicable, of publication be cited.

Current JPRS publications are announced in Government Reports Announcements issued semi-monthly by the National Technical Information Service, and are listed in the Monthly Catalog of U.S. Government Publications issued by the Superintendent of Documents, U.S. Government Printing Office, Washington, D.C. 20402.

Correspondence pertaining to matters other than procurement may be addressed to Joint Publications Research Service, 1000 North Glebe Road, Arlington, Virginia 22201.

EAST EUROPE REPORT
SCIENCE & TECHNOLOGY
CONTENTS

BULGARIA

Need for Trained Personnel in Robotics Industry Outlined
(Yulian Danchev; TEKHNIЧЕСКО ДЕЛО, 23 Jun 84)..... 1

New Computer Industry Product Advertised
(TEKHNIЧЕСКО ДЕЛО, 23 Jun 84)..... 4

GERMAN DEMOCRATIC REPUBLIC

Decentralized Data Acquisition To Remedy EDP 'Bottleneck'
(Bernd Ahner; RADIO FERNSEHEN ELEKTRONIK, No 1, 1983)..... 5

Underwater Television Equipment Described
(Dieter Borgelt, et al.; RADIO FERNSEHEN ELEKTRONIK,
No 2, 1983)..... 10

Leipzig To Host 1984 High Energy Physics Conference
(Karl Lanus Interview; SPECTRUM, No 6, 1984)..... 21

HUNGARY

Recent Developments in Ryad System
(Zoltan Szabo; SZAMITASTECHNIKA, Mar 84)..... 24

Recent Hungarian Developments in Minicomputer System
(SZAMITASTECHNIKA, Jun 84)..... 29

Remote Data Processing System Software in Hungary
(Gabor Pados, Sandor Nagy; SZAMITASTECHNIKA, Jun 84)..... 31

Briefs

Robots in Operation 35

Orion Graphic Display 35

Datacoop Achievements 35

POLAND

Ecologically Threatened Areas Described

(WIADOMOSCI STATYSTYCZNE, No 5, May 84; RZECZPOSPOLITA,
26 Apr 84)..... 36

Water, Air Pollution, Control, by Stefania Rola-Kunach
Pollution From Neighboring Countries

NEED FOR TRAINED PERSONNEL IN ROBOTICS INDUSTRY OUTLINED

Sofia TEKHNICHESKO DELO in Bulgarian 23 Jun 84 pp 1,3

[Article by engineer Yulian Danchev: "Rototization and Scientific-Technical Unions"]

[Text] Robots and robotization became a topic of conversation more than 10 years ago when the problem of labor intensification in discrete productions, and more specifically in machine building, became more acute. Modern, highly productive machines began to appear at plants; their optimal use began more and more clearly to exceed the physical capabilities of even the most highly trained and conscientious workers. On the other hand, claims on the quality of products and the precision of processing also grew, which, combined with the requirements of high productivity, demonstrated even more definitely the only correct and possible outcome of the contradiction that has arisen, that is, complex automation by introducing robots and computers.

At the same time that productivity was increasing, thanks to automation, the problems of rapid readjustment of automated lines and sections came to the foreground because machine building production is characterized by short series. Thus, the idea of flexible automated technological structures, the realization of which is basically impossible without the use of computer controlled robots, was born.

Third, the chronic shortage of highly trained main workers, such as turners, millers, etc., which is related to the less than favorable demographic tendencies, is another reason which forces all industrialized nations to turn to robots.

These are, generally speaking, the reasons which predetermine the development of robotics in our country. They were noticed in time, and even during the Seventh 5-Year Plan resolutions were made at the governmental level for creating corresponding production capacities for the production of robots and manipulators. The 12th Party Congress specified the tasks of Bulgarian robot builders as follows: "To increase the production of robots, manipulators, and robotized technological modules, and to proceed to the complex automation of whole workshops, and subsequently to whole plants." In fulfilling this assignment during the period of the Eighth 5-Year Plan (1981-1985), it will be necessary to introduce and use 3,000 robots and manipulators, which will

replace the labor of around 12,000 workers. It is expected that the labor productivity in the robotized sections will be 1.5 to 3 times higher, which will have a direct economic effect of several dozen million leva.

There is no doubt that this is a task of great magnitude for our industry. In order for it to be fulfilled, many problems of a technical, organizational, and social nature must be solved. But among them the problem of rapid and high quality training of specialists, who must take part in the implementation and afterwards the operation and repair of robots and robotized technological modules and lines, stands out as particularly acute.

The production of robots and manipulators in our country has developed rapidly and has taken on such a high rate of production that now it is possible to satisfy all the needs of our country. What is more, Bulgarian robots and manipulators are already being exported on the international market, chiefly to the socialist countries. But if the success in the production of robots is indisputable, the situation with regard to their implementation is totally different. Here the rates of their implementation are still unsatisfactory. Robots are coming slowly into industrial enterprises, for many different reasons, one of which is the shortage of cadres for implementing them.

Although the problem of training specialists in robots was discussed long ago and quite a bit has already been done, there are clearly not enough of them trained at higher and mid-level technical schools, including the postgraduate education system. Those so trained tend primarily toward robot construction, although essentially implementing and operating robots are the areas which need to be filled precisely with cadres in an urgent and massive way. This problem is made more complicated by the fact that robotization is a complex process which requires specialists with different training, especially when dealing with designing, mounting, and operating flexible automated production systems (FAPS).

In addition to direct participants in implementing, operating, and repairing the robots, the competency of leaders, at all levels, in the matter of robotization is of great significance. Their competency is the basis on which conviction of the necessity for implementing robots can be formed, and practical actions should follow afterwards. This is why the general training and adequate preparation of leaders in the matter of robotics is also an important problem, the solution of which should not be underestimated.

The seriousness of this problem requires the purposeful mobilization of all institutions which prepare technical cadres, so that industry can be supplied on time with the necessary cadres for implementing and operating robots. Undoubtedly the scientific and technical unions can make a contribution in this great and complex matter -- they have their own instructional methods, tested in practice, as well as the social support, which can be brought to bear on implementing robots. For this aim, a program which has already been developed and accepted foresees that, during the period of 1984-1985, about 1,500 specialist, leaders, and workers will be trained. Taking into account the complexity of the problem, the task will be accomplished in steps. First

of all, lecturers need to be trained with the organization of three courses, and later they will conduct the training course. The courses will use the most modern methods of instruction and maximal audio-visual aids, including video tape. In the future, this program anticipates including specialists trained in this way in solving separate problems in the automation of discrete productions with the application of robots.

Another form of social support for the process of robotization is organizing courses, within forms, for training the robots's users. In this case, at the present time, we anticipate a specialized laboratory on robotics at the Scholarly Centre associated with the House of Technology in Stara Zagora. Robots have already been purchased and supplied, the necessary models and audio-visual control panels have been created, equipping the lecture halls is now underway. Undoubtedly this specialized laboratory will noticeably strengthen the efforts of the Beroe scientific-technical combine in Stara Zagora in its difficult and responsible process of training the cadres of users in the effective and rational use of the robots it produces.

Robotization in Bulgaria is still at the beginning of its long and difficult path, but this is the only way. The social support which scientific and technical unions are giving it while it takes its first steps will undoubtedly bring about its future success, which we count on and which we do not doubt.

12334
CSO: 2202/16

BULGARIA

NEW COMPUTER INDUSTRY PRODUCT ADVERTISED

Sofia TEKHNICHESKO DELO in Bulgarian 23 Jun 84 p 14

[Text] Integrated Plants for Memory Devices--Plovdiv

One of the newest developments, which has been put into regular production by the Integrated Plants for Memory Devices in Plovdiv, is an automatic printing control device (APCD), the UUPU ES 9070, which allows the costs of processing information to be decreased significantly and valuable machine time to be saved. Instead of being printed on paper, the output information is put on magnetic tape about six times more quickly. The information recorded on magnetic tape is printed at a rate controlled automatically by the UUPU ES 9070, and the computing system is freed to solve other problems. Recording the information on magnetic tape is performed under the control of an existing software system, without having to change applied programs.

The UUPU ES 9070 is designed for work at computing centers, industrial enterprises, warehouse concerns and all places where there is a need to print huge amounts of information after it has been processed by a computer.

For information contact: Integrated Plants for Memory Devices--Plovdiv

Telephone: 34-91

Telex: 44411

Exporter: Izotimpeks Foreign Trade Corporation - Sofia

Telex: 22731

Telephone: 74-61-51

12334

CSO: 2202/16

DECENTRALIZED DATA ACQUISITION TO REMEDY EDP 'BOTTLENECK'

East Berlin RADIO FERNSEHEN ELEKTRONIK in German Vol 32 No 1, 1983 pp 8-11

/Article by Dr Bernd Ahner, Engineer/

/Excerpts/

Efficient data acquisition has developed into one of the most important problems in modern data processing. The present paper is concerned with some aspects of the decentralization of data acquisition while using modern detection techniques.

In the entire national economy, the production of data that need to be acquired and processed is constantly increasing. While powerful devices are available for data processing - from the hand calculator through micro-computers up to main-frame computers with processing speeds of millions of operations per second - the acquisition and primary preparation of the incident data poses considerable difficulties. This contradiction between the power of modern EDP systems on the one hand and partly antiquated input methods on the other hand has not diminished in recent years but rather has increased (1). Thus data acquisition remains problem number one in many areas of the economy. Not unjustly this is also frequently called the "bottleneck" of EDP. Although major organizational and engineering efforts have been undertaken in this area recently, data are for the most part still acquired indirectly through intermediate data media and are inputted centrally into the computer in the batch processing mode. This form, now as before, is important for mass data which need not be directly processed. In the GDR, adequate technical means are also available for this within the framework of the production program of the VEB Combine Robotron (2). However, in other cases it appears necessary to pay more attention to automatic data acquisition as a direct path. This is more economical, more reliable, and considerably faster.

Possibilities of Data Acquisition

In connection with automated methods of data acquisition, one must regard the forms of centralized and decentralized acquisition.

Centralized Data Acquisition

Centralized (or indirect) data acquisition exists when the original documents are not evaluated immediately but are transported from the site where they are generated to special acquisition sites. Data media are there created in a centralized fashion. These permit further processing on main frame computers or the like, while the original documents are generally returned to their source. Acquisition at the central site requires corresponding units and specially trained employees. According to (3), this involves three work-intensive and time-intensive conversion processes with manual input; time-consuming transportation processes must be managed, and correction cycles must be executed. Figure 1 is intended to clarify this. The multiple manual data input has an especially negative effect, since it is severely subject to errors.

Decentralized Data Acquisition

Besides centralized acquisition, more recent development is aiming more and more in the direction of decentralizing these processes, i.e. acquiring the data at the site where they arise. This decentralized (or direct) acquisition is generally not performed by special personnel but by the originator of the data himself, in principle in addition to his normal activity. It is therefore a form of data acquisition that is related to the work place. The incident data are here converted to machine-readable data media or are inputted into the EDP system by means of remote data transmission. The acquired data can here be checked for correctness and completeness during the acquisition process, sometimes visually (protocol, display screen) or sometimes by program-controlled error tests. Naturally, other hardware is required for this decentralized acquisition (e.g. mobile data acquisition units) than for central acquisition.

Comparison

In the case of centralized data acquisition, disadvantages arise from the above-mentioned multiple conversions on intermediate data media:

- multiple work, associated with the tie-up of qualified employees;
- garbling of information through multiple transfers;
- considerable time delay through excessive labor and transportation times.

On the other hand, decentralized acquisition offers advantages:

- retention of the natural data and work flow;
- avoidance of duplicate work;
- avoidance of work surges in the case of discontinuous data production (higher efficiency for the procedures);
- error test during the acquisition, whereby the possibilities of errors are reduced, since the technical personnel at the source itself manages the data acquisition;
- current status of the data.

Various methods exist for decentralized acquisition, such as:

- utilization of special keyboard input units that are oriented towards the work station (2);
- use of mobile, keyboard-oriented data acquisition units, possibly with coupled optical sensors including subsequent data transmission (remote data transmission of automatically via the telephone);
- direct reading of suitable data media (documents, labels, etc.) by means of special devices. A necessary condition for this is that the data exist on machine-readable data media;
- input by means of a light pencil on the video work station;
- acoustic (voice) input.

This enumeration shows that decentralized data acquisition uses modern devices and procedures, which frequently also permit automatic or semi-automatic acquisition. Detection methods, optical as well as acoustical ones, as well as other methods, are well suited for these purposes. In the future, these methods will have good opportunities, as is shown by a trend analysis from the USA, concerning the development of systems for automatic data acquisition (Figure 2). This analysis is cited in reference (4).

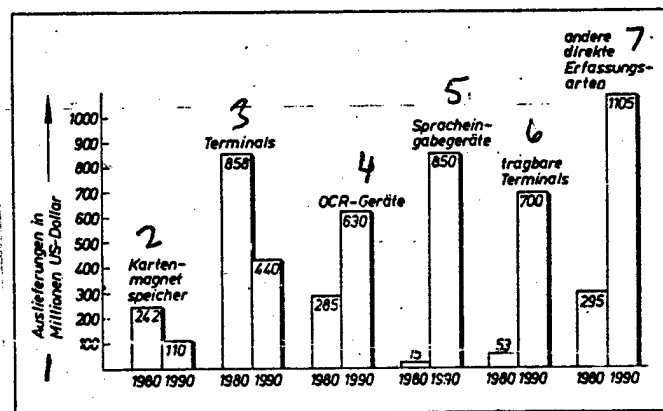

Figure 2: Trend to Automatic Direct Data Acquisition in the USA
Key:

1. Deliveries in millions of US dollars
2. Cards - magnetic memory
3. Terminals
4. OCR units
5. Voice input units
6. Portable terminals
7. Other direct acquisition modes

Summary

The constantly growing volume of data today requires specific efforts for their acquisition, to widen out this "bottleneck of EDP". New paths must be trod here. Decentralized data acquisition is such a path to make the

acquisition process more efficient. Technical character recognition and acoustic recognition are components thereof. There are manifold application opportunities for these techniques, which sometimes can even be mobile. At the same time, these applications, together with the experience gained in this connection, prove that suitable and powerful devices are available. The task now is to complete these methods in a goal-oriented manner, and thus to render a contribution towards the efficient acquisition of data at the site where they are generated.

BIBLIOGRAPHY

1. Schober, R., Heusing, E.; Data Acquisition - a Task for the Efficient Utilization of EDP. NACHRICHTENTECHNIK · ELEKTRONIK (Communications Technology, Electronics), Berlin 30, 1980 4, pp 138-140.
2. The Production Program of the Decentralized Data Technology of the VEB Combine Robotron, New Technology in the Office, Berlin 25, 1981 2, pp 38-43
3. Licht, R.; Possibilities of Data Acquisition. BÜROTECHNIK (Office Technology), Baden-Baden 23, 1975 6, pp 537 to 643.
4. Güttinger, P., Oberfeuchtner, G.; Quickly and Reliably Into the Computer. Data Report, Berlin/Munch 15, 1980 5, pp 19-23.
5. DIN 66 236, Parts 1 through 5. Document SC for Machine Character Recognition.
6. Digital Bar Code Wand HEDS-3000 and Optical Sensor HEDS-1000. HP Optoelectronics Catalog, 1980.
7. Ruby Wand Light Pencil Model 1232. Datentechnik GmbH, 1979.
8. Uebbing, J., Lubin, D. L., Weaver, E. G. Jr.; Handheld Scanner Makes Reading Bar Codes Easy and Inexpensive. HP Journal, Palo Alto 32, 1981 1, pp 3-10.
9. Patent Specification DT-OS 2 822 667, G 06 K, 4/1/79.
10. Patent Specification DT-OS 2 822 573, G 06 K, 4/1/79.
11. Lemme, H.; Lasers in Practical Application. ELEKTRONIK (Electronics), Munich 30, 1981 10, pp 43-51
12. Scanners for Experts - A Cash Register System Speeds up Customer Dispatching. Online - adl - communications. Cologne 18, 1980 1-2, p 27.
13. Beckmann, D.; Data Acquisition in a Wink, Data Report Berlin/Munich 15, 1980 6, pp 29-33.

14. Transdata OCR - Manual Reader 9005, September 1979.
15. Terhardt, E.; What is Automatic Speech Recognition? ELEKTRONISCHE RECHENANLAGEN (Electronic Computer Systems), Munich 20, 1978 4, pp 178-186.
16. Tscheschner, W., Kordon, U.; Technical Systems for Automatic Speech Processing. RADIO FERNSEHEN ELEKTRONIK (Radio Television Electronics) Berlin 29, 1980 2, pp 83-87.
17. Balanescu, A.; Speech Recognition: Theory and Application in Microcomputers. ELEKTRONIK (Electronics), Munich 29, 1980 19, pp 91-97.
18. Data Input With Natural Language. BZB SACHMAGAZIN (Civil Defense Professional Journal), Hamburg 83, 1980 5, pp 28-31
19. Tiersch, F.; An Alternative to Conventional Data Acquisition Technology. RECHENTECHNIK DATENVERARBEITUNG (Computer Technology, Data Processing), Berlin 13, 1976 4, pp 63-66.

8348
CS0:2302/66

UNDERWATER TELEVISION EQUIPMENT DESCRIBED

East Berlin RADIO FERNSEHEN ELEKTRONIK in German Vol 32 No 2, 1983 pp 76-79

/Article by Dieter Borgelt, Engineer; Arno Kiebusch, Physicist; Lutz Lippmann, Engineer; Volker Schwuchow, Engineer; Announcement from Wolgast VEB Peene Shipyard

/Text An underwater television system for general observational purposes was developed on the basis of an industrial television camera for remote observation. Such an underwater television system is required for underwater work, inspection, research, salvage, and search.

In commercial, scientific, and official underwater engineering, significant advantages accrue from the utilization of underwater television systems. These advantages arise from the possibility of specifically observing processes or objects, long-term observation, and the documentation of observation. The information obtained is simultaneously made available to a larger group of persons and furthermore it can be stored by video-screen photography or by a video tape unit. This further increases the utility of such observations.

Underwater television systems are being used more and more for oceanographic research tasks, but also for fishery and shipbuilding research, in the study of underwater structures or obstacles, for checking sea cables and pipelines, and in performing salvage operations, when verifying and repairing underwater damage on ships or docks, when mapping the sea bottom, when dealing with submarine storage places for raw materials, when monitoring and supporting diver operations in dangerous situations, etc.

The light, compact, and portable underwater television system which is presented below is primarily intended for shallow water use up to a depth of about 25 m. It features simple operation by the observer and easy handling by the diver. It was designed and implemented for trial and experimental purposes in general applications and is used primarily to find and optimize solutions for the electrical-electronic and optical part. For this reason, the design of the underwater housing, especially the bolting system for the flat window, and the design of the camera housing itself has not yet been paid the required attention.

Mechanical Structure

Underwater Camera

The underwater housing for the TFK 500 camera (1) is a welded, rectangular aluminum body (Figure 1) whose front side is sealed by a rectangular, fracture-proof flat window. The back side contains an underwater plug connection (2), and two watertight bolt connections. When these are loosened, the beam current and the sharpness can be regulated without removing the camera. The flat window consists of fracture-proof safety glass. The connection between the window and the housing is made watertight by a special profiled flat rubber gasket.

Figure 1: Underwater Camera (230 mm X 165 mm X 400 mm)

When the window is removed, the camera itself can be inserted into the housing through a double-groove guide, and it can be fixed by means of a screw connection. The underwater camera is counterbalanced in the water by means of a massive retaining and guide plate.

Remote Operation

For remote operation, the remote operation attachment FZ 20.50 (3) was modified. It contains the power supply-, filter-, and electronic-modules. The keys, the line connection, and the sockets for the monitor and coaxial cable are accessible from the outside. Indication of the line voltage is afforded by a control light.

Cable

200 m coaxial HF cable (Type 75-4-1, VEB Cable Works Vacha) are used as the cable. The associated cable drum is an aluminum design in the usual construction.

One special feature is that the beginning of the cable is brought out through a coaxial rotary coupling. This is a modification of a 50-ohm angle connector (Type 50-12-t6, VEB Electronic Components Dorfain). It facilitates picture transmission even while the coaxial cable is being wound on or off.

Electrical Structure

Block Circuit Diagram (Figure 2)

To guarantee contact-voltageproof operation, the underwater part of the system is operated through an isolation transformer with an extra-low voltage. The power supply as well as the control signals for remote optical operation and the video signal are transmitted through a common coaxial cable. Consequently, filter circuits take care of proper separation of individual frequency ranges. The frequency interval was chosen so that no special requirements need be imposed on the filters.

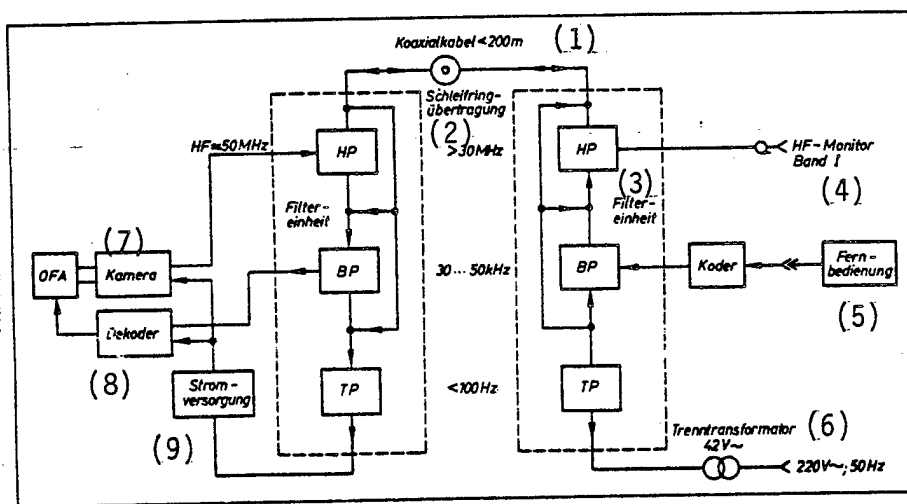

Figure 2: Block Circuit Diagram of the Underwater Television System
Key:

- | | |
|--|-------------------------------|
| 1. Coaxial cable <math>< 200\text{ m}</math> | 6. Isolation transformer 42V~ |
| 2. Slip ring transmission | 7. Kamera |
| 3. Filter unit | 8. Dekoder |
| 4. HF monitor, Band I | 9. Power supply |
| 5. Remote operation | |

The operating voltage passes through the low-pass filters and a portion of the high-pass filters and thus directly reaches the transformer of the camera. There the operating voltage is produced for the camera, for remote optical operation (4), and for the associated decoder. The positioning instructions for the remote optical drives are transmitted through the band-pass filters as associated frequencies. They are decoded in the decoder, and the remote optical drive is controlled as regards aperture and range.

The signal delivered by the camera modulates an HF carrier (55.25 MHz), which is conducted to a television receiver via the high-pass filters.

Remote Operation

The remote operation attachment houses the power supply, the filters, and the frequency generators for controlling the remote optical drives.

Frequency Generator

A slightly modified circuit board of the ultrasonic generator (5) is used as frequency generator. In place of the ultrasonic converter, the generated sinusoidal vibrations are coupled out through an RC combination in a low-ohm manner. The vibrations themselves are generated by applying the frequency-determining capacitor to the oscillating circuit (Figure 3).



Bild 3: Frequenzgeber für die Multiplexfernsteuerung des Optikkferntriebes (nach [9])

Figure 3: Frequency Generator for the Multiplex Remote Control of the Remote Optical Drive (After (5))

The peak voltage delivered by the frequency generator to the band-pass filter (Figure 4) is about 1.5 V for frequencies of 36.9 kHz, 40.8 kHz, 42.7 kHz, and 46.7 kHz. These frequencies encode the instructions "aperture open", "aperture closed", "range 0", and "range ∞". The power supply of the generator is provided by a transformer with a rectifier, which is installed in the FZ 20.50 (3), including additionally a Z-diode for stabilization.

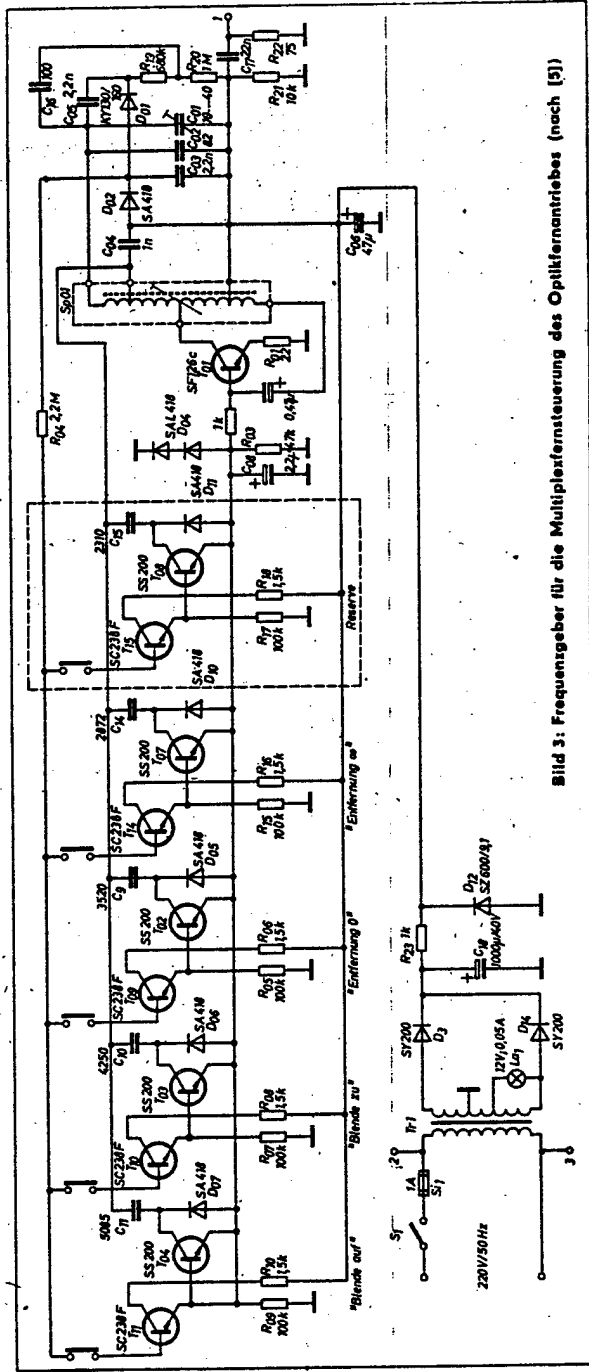
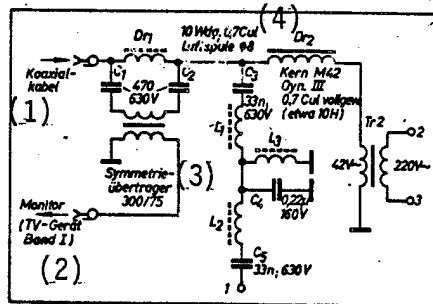

Figure 4: Filter Section of the Remote Operating Unit (L_1 , L_2 , L_3 dimensioned according to (6); 1, 2, 3 are the connection points with the corresponding points in Figure 3)

Key:

1. Coaxial cable
2. (TV unit Band 1)
3. Symmetry transmitter 300/75
4. 70 turn, 0.7 Cu1 air-coil $\varnothing 8$
5. Core M42 Dyn. III 0.7 Cu1 fully wound (about 70 H)

Filter Section

The filter section consists of a high-pass, band-pass, and low-pass filter (Figure 4). The high-pass filter separates off the HF signal that comes in through the coaxial cable (55.25 MHz). The HF is available through Dr_1 , and it is conducted to the symmetry transmitter with C_1 , C_2 . This symmetric coupling in of this frequency reduces noise through the hum bar on the video picture. It is coupled out at 75 ohms, unsymmetrically, for a coaxial connection to the video receiver.

The band-pass filter makes possible the frequency-multiplexed transmission of the control frequencies for the remote optical drive. The 3-dB bandwidth is 20 kHz, the attenuation with respect to the line frequency and the HF is greater than 60 dB. It is designed as a simple T-element (6).

The low-pass filter consists essentially of Dr_2 in combination with Tr_2 . The high inductance of Dr_2 prevents frequencies greater than 10 kHz from flowing off, but represents no significant attenuation for the line frequencies. The

influence of different loads (current flow) through Dr_2 on their inductance is reasonable, since the inductance and thus also the filter action reduce by about 3 dB at a maximum current flow of 3 A. In the case of currents of about 1 A, such as occur in actual practice, the displacement of the filter curve is minimal.

Underwater Camera

The camera housing houses not only the camera but also the remote optical drive, the decoder to control the remote optical drive, the filter unit, and the power supply.

The filter unit (Figure 5) is identical with that of remote operation, i.e. analogous to the transmission side, individual frequency ranges are here split up. The modulated HF signal from the camera is impressed on the coaxial line via the high-pass filter.

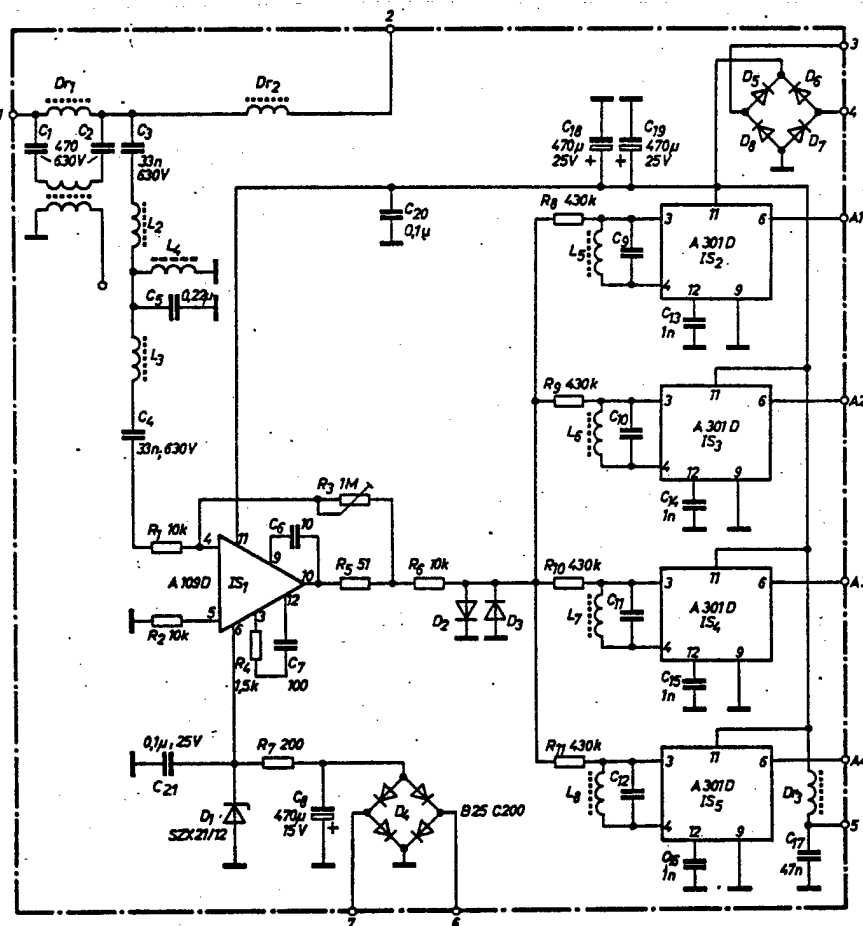

Figure 5: Supplementary Modules for the Underwater Camera (Decoder, Filtering Unit, Power Supply; L_2, L_3, L_4 Dimensioned According to (6); the Frequency-Determining LC Combination According to (5) with $C = 300 \dots 400$ pF)

The camera itself is a modified design of the TFK 500-5. The modification refers on the one hand to the use of a multidiode target endicon and the required circuit changes (7) and on the other hand to the redimensioning of the transformer of the camera to the extra-low signal voltage and to the supplementary supply of the additional modules.

The frequency portion that is screened out by the band-pass filter is amplified by an A 109 operational amplifier, is limited by D₂ and D₃, and is conducted to the filters with triggers (L₅ through L₈, C₉ through C₁₂, IS₂ through IS₅). When the associated frequencies are present, these activate the appropriate relays in the remote optical drive.

The remote optical drive is an OFA 2010 (4) without housing. The following modifications were required as regards the electrical design:

1. Relays Rs₁ through Rs₄ are replaced by a 12-volt design
2. The diodes Gr₂ and Gr₃ are repoled.
3. Shunt between Lp₉ and Lp₁₃
4. Lp₁₀ (pin 3 blue) to pin 6 (ground)
5. Lp₁₃ (pin 6 white) to pin 3 (+12 V)
6. Pin 2, white, unsoldered and insulated
7. Terminals 7 of Rs₂ and Rs₃ at pin 2 and pin 5 are shunted.

Allocation of the plug connections:

- 3, 4 - aperture
- 2, 5 - range
- 1 - +12 V
- 6 - ground.

For reasons of space, the OFA was turned by 90 degrees in its fastening points at the camera (Figure 1). The circuit board with the additional and supplementary modules (filtering unit, power supply, and decoding unit) thus could be arranged in a space-saving fashion behind the remote optical drive, in parallel with the corresponding circuit board of the camera.

Expansions and Improvements

To check underwater parts on ships for damage, by means of inspection boats and without using divers, as well as for observing ship models underwater in the drag or flow channel, one uses a streamlined extension arm (Figure 6). This houses the remotely operated camera and can internally also tilt it mechanically to increase the vertical observation angle that is of interest.

For special tasks or basic scientific-technical researches, where high optical precision is necessary, the plane-parallel window that is customary for general applications can also be replaced by a spherical window with a correcting lens. This arrangement avoids image distortions and beam refractions which occur during the passage from water into air and which restrict the field of view. As a result of this, the opening angle in water remains nearly unchanged.

Figure 6: Extension Arm for the Camera for Underwater Observations in the Drag or Flow Channel and From the Inspection Boat (Camera Not Installed)

As regards a miniaturization of the underwater camera, a better design for the shape of the underwater housing, and better handleability, the remote optical drive (4) was dispensed with, and this was replaced by rudder machines, such as are customary with remote model controls. For this reason, the above-mentioned remote operation principle was no longer used, but the associated digital-proportional radio control (9) was utilized, which works according to the principle of pulse-length modulation.

The main advantage in using the remote control system is that, in virtue of the design of the servo amplifier as a slave control, the positioning path becomes approximately independent of the mechanical load.

The block circuit diagram of the remote camera operation and the remote optical control by means of a radio control system (9) is shown in Figure 7. In place of the antenna, a coaxial cable is here connected to the remote observation system, and the filter unit (6) shown in Figure 8 is inserted.

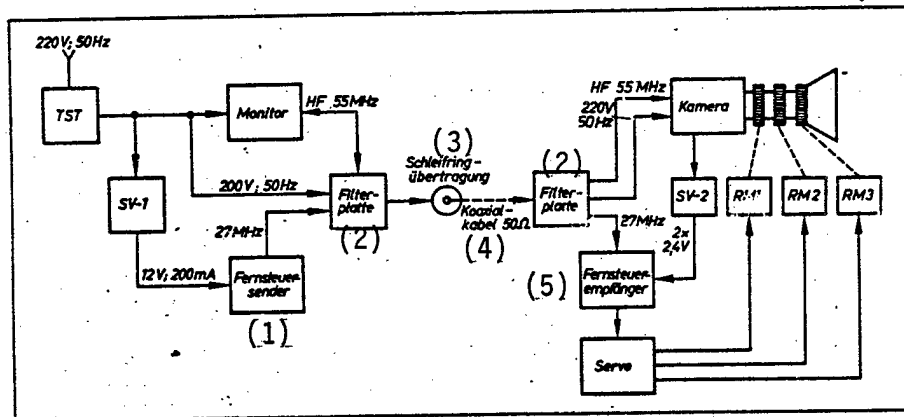

Figure 7: Block Circuit Diagram of the Remote Camera Operation With Radio Control System (9)

Key:

1. Remote control transmitter
2. Filter board
3. Slip-ring transmission
4. Coaxial cable 50 ohms
5. Remote control receiver

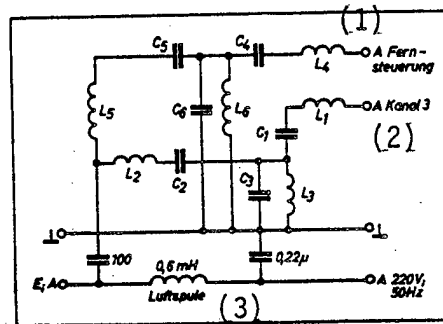

Figure 8: Filter Unit for the Remote Operation With Radio Control System (9)

($L_1 = L_2 = 19$ turns, $\varnothing = 7$ mm; $L_3 = 2$ turns, $\varnothing = 7$ mm;
 $L_4 = L_5 =$ USW chalking core $10 \mu\text{H}$ with $10 \dots 12$ turns;
 $L_6 = 3 \dots 5$ turns; $\varnothing = 4$ mm; $C_1 = C_2 = 6.8$ pF;
 $C_3 = 100$ pF; $C_4 = C_5 = 8.2$ pF; $C_6 = 350 \dots 800$ pF)

Key:

1. Remote control
2. Channel 3
3. Air coil

Figure 9 shows a correspondingly modified TRK 500 camera with rudder machine (8) to activate the optics and an angled endicon for the better design and handling of the underwater camera housing. The supplementary modules such as the power supply and line filtering unit are disposed in the angle area below the rudder machines.

Since the remote control system is delivered at least as a three-channel system, the possibility exists of also controlling zoom lenses at the same time. In the interest of reliable handleability and interference-proof operation of the underwater and remote observation system with remote camera activation by the radio control system (9), it is also recommended to dispense with battery operation and to install an appropriate power supply module.

Figure 9: View of the TKF 500 Camera With Rudder Machine for Activating the Optics and With Angled-out Endicon

Supplementations

So that the underwater television system should become usable for its various tasks and deployment conditions, it can be supplemented by underwater searchlights which preferably consist of halogen searchlights, such as are used in motor vehicle technology:

- Diver Cable Searchlight (24 V/70 W)

The diver cable searchlight is fed from an associated power supply unit, which also contains the corresponding plug connectors, or else is fed directly from an appropriate 24-V onboard network. The easy handleability of the diver cable searchlight depends on the line cross section, i.e. on the cable diameter. It is determined by the amount of cable length required and is variable within wide limits. The cable is connected to the searchlight rigidly by means of the customary cable leads that are tight against pressurized water. Despite its relatively large light power, the diver cable searchlight is sufficiently small and, depending on the cable type, is light and handy.

- Manual Diver Searchlight (12 V/25 W)

The manual diver searchlight preferably has a set of NC collectors, which can be recharged without disassembling the battery container. An optical under-voltage check makes possible optimal use conditions by appropriately designed load cycles since a warning is given against dangerous excessive discharges of the battery set. The manual diver searchlight has a switch that can be operated under water and can easily be guided manually under water by means of an underarm support.

Final Remark

The underwater television system presented here is designed as a means to make general underwater application more efficient and more intensive. In this way, further modifications for special applications do not appear promising, since these would require a basic problem-oriented development. For this reason, reference is made to reference (10) among others, as regards the inspection of wells and drill holes.

BIBLIOGRAPHY

1. Description and Operating Directive for the TFK 500.5 Transistor TV Camera. VEB STUDIOTECHNIK Berlin, Edition 5/77.
2. Kiekbusch, A.; Underwater Plug Connectors. SEEWIRTSCHAFT (Maritime Economy) Berlin 14, 1982 5, p 255.
3. Description and Operating Directive of the FZ 20.50 Remote Operation Supplement. VEB STUDIOTECHNIK Berlin, Edition 2/73.
4. Description: OFA 2010 Remote Optical Drive. VEB STUDIOTECHNIK Berlin, Edition 2/73.
5. Erler, H., Welzel, H.-J.; Luxotron 116 - an Example of the Systematic Increase of Use Value in the Television Device Sector. RADIO FERNSEHEN ELEKTRONIK (Radio Television Electronics), Berlin 23, 1974 19, pp 625-630.

6. Kronjäger, O.; Amateur Technology, Berlin: Military Publishers of the GDR 1973.
7. Kullmann, J.; The Hybrid Endicon With a Silicon Diode Target - a Novel Television Picture-Taking Tube. RADIO FERNSEHEN ELEKTRONIK (Radio Television Electronics) Berlin 24, 1975 22, pp 717-721.
8. Operating Directive Proportional-Rudder Machine "Seryomatic 15 S". VEB Automotive Accessories Reinhardtsgrimma.
9. Description, Service Documents, Operating Directive for the Radio Control System Start dp 3. PGH RADIO-FERNSEHEN (Radio-Television) Freiberg.
10. Will, H.; Channel Tube Television System, RADIO FERNSEHEN ELEKTRONIK (Radio Television Electronics), Berlin 27, 1978 4, p 208.

8348
CSO:2302/65

LEIPZIG TO HOST 1984 HIGH ENERGY PHYSICS CONFERENCE

East Berlin SPECTRUM in German Vol 16 No 6, 1984 pp II-III

/Interview with GDR Academy of Sciences member Karl Lanius, Director, Institute for High Energy Physics, by Elisabeth Manke/

/Text/ We asked Professor Siegmund Novak of the Institute for High Energy Physics about the events at the 22nd World Conference. He informed us that, during the first 3 conference days, 23 parallel sessions will take place, among other things on the following central topics:

- unified theories for the strong, electromagnetic, and weak interactions, and their experimental verification
- creation mechanisms and decay of new particles.

In addition, questions concerning the relation between elementary particle physics and cosmology will play a role. Another complex is dedicated to experimental techniques.

The various groups of scientists will present their results at the parallel sessions.

The 18 plenary lectures will be presented during the last days of the conference. These lectures summarize problems of the parallel sessions.

From 19 to 25 July, high energy physicists from all over the world will meet in Leipzig. What are the concerns of this conference?

Prof. Lanius: This world congress of high energy physicists is instituted by the International Union for Pure and Applied Physics (IUPAP) every 2 years. The Leipzig meeting is the 22nd one of its kind. The last three congresses took place in Tokyo in 1978, in Madison USA in 1980, and in Paris in 1982. Participation in these conferences is possible only by a personal invitation. About 1,000 high energy physicists, theoreticians and experimentalists from many countries, gather at this meeting. During the first 3 days of the conference, the various experimental and theoretical subfields of high energy physics are discussed in parallel sessions. Reports on individual original research or groups of original researches form the basis of the discussions.

The plenary sessions take place during the last 3 days of the conference. Here, lectures are presented concerning the progress achieved and its evaluation. The lectures are given by previously selected correspondents.

As you can see, this conference is concerned with an overall view and critical evaluation of progress achieved during recent years.

What scientific contributions will GDR scientists make to the conference?

Prof. Lanius: Experimental high energy physics is carried on in close international cooperation at the Institute for High Energy Physics of the Academy of Sciences of the GDR, while theoretical groups are active predominantly at Karl-Marx University in Leipzig and Humboldt University in Berlin. The GDR scientists will appear both as correspondents in the plenary and parallel sessions and also as discussion leaders of parallel sessions. To mention only two examples, Dr. Kripfganz, Karl-Marx University Leipzig, will be correspondent on lattice gauge theories at one of the plenary sessions, while Dr. Max Klein, Institute for High Energy Physics Zeuthen, is discussion leader on experiments concerning neutral currents and interference effects.

The number of original papers which GDR scientists are submitting to the conference will certainly exceed 20. For exact data, the time of our interview is still too early, since all these original papers are currently in the status of being completed or produced. The official deadline by which all original papers must be submitted is 15 June.

What outstanding results arise from the close cooperation with the Soviet Union? Could you mention one or two of them?

Prof. Lanius: Both in the theoretical and experimental areas, there has for many decades been close collaboration with scientists in the Soviet Union. The centers of collaboration are the United Institute for Nuclear Research in Dubna and the Institute for High Energy Physics in Serpuchov.

One of the current component areas of modern high energy physics is neutrino physics. Neutrinos were demonstrated experimentally only a few decades ago. The reason is that they are so hard to observe, because they interact extraordinarily rarely with other forms of matter. We therefore also speak about a weak interaction. Neutrinos and their weak interactions are investigated in Serpuchov by means of a very large special detection instrument. A collective of the Institute for High Energy Physics in Serpuchov and a collective of our own institute participate in these investigations. At the Leipzig Conference they will present some of the interesting new results, for instance concerning the character of the weak interaction.

Another example are theoretical investigations on the gauge theory of the strong interaction. The strong interaction is known to us all as the force which holds together the atomic nuclei. From appropriate experimental investigations we know that the components of the atomic nuclei, the neutrons

and the protons, on their part are composite structures. They consist of quarks. But up to now it has not yet been possible to observe quarks as free particles. They always remain enclosed in neutrons and protons and also in many other similar observable particles (mesons and hyperons). The attempt to understand the bound states of quarks theoretically, led to quantum chromodynamics, a gauge theory of the strong interaction. Now, in order to describe such bound quark states, very laborious and complicated calculations are necessary. Theoreticians from Berlin and Leipzig, in close contact with their colleagues in Dubna, have developed such calculational methods. They too will report their most recent results in Leipzig.

8348

CSO: 2302/64

RECENT DEVELOPMENTS IN RYAD SYSTEM

Budapest SZAMITASTECHNIKA in Hungarian Mar 84 p 7

/Article by Dr Zoltan Szabo: "Recent Developments in the ESR." (Note: The Hungarian "ESzR" /Uniform Computer Technology System is the equivalent of the Russian "Ryad"; the Hungarians use "MSzR" for the corresponding minicomputer system)

/Text With this second article in a series describing ESR and MSR activity I would like to supply something which has been missing. Thus far, unfortunately, relatively little information about ESR products reaches the user, and that rarely. In the following I will describe a few recently developed ESR hardware products indicating the developing country and the year development was completed.

ES 1016 Universal Computer (Hungary, 1983)

The computer is a modernized version of the ES 1015 model in the ESR second series. The chief characteristics of the model are:

--Extended precision (28 hexadecimal character) floating point operations. Average performance: about 25,000 operations per second.

--Dynamic address translation which makes possible use of a maximum of 16 M bytes virtual memory for one program. The capacity of operating memory is maximum 1 M byte.

--The memory protection with the dynamic address translation ensures protection of the contents of main memory against inappropriate use, and this makes possible the simultaneous running of applications presenting different security requirements.

--A developed machine error management mechanism which extends to automatic error correction for the central memory, repetition of instructions and commands and the recording of machine status information.

--In the course of executing programs the system checks the correctness of instructions and data and distinguishes between program errors and device errors.

--Direct connection (without need for a separated control unit and selector channel) to 29 M byte capacity, fast access disk memory units, which can be used for online data and program storage.

--Optional integrated adapters for direct connection for card reader/punch, printer, magnetic tape units, data transmission equipment and console printer.

--Picture screen console and keyboard for the operator-system link and simple online querying.

--Extended hardware error checking and automatic error journaling.

--Microdiagnostics extending to every integrated part of the system.

--The ESR DOS 3 operating system or one compatible with it.

--Extended remote data processing devices, the interface for which is a hardware multiplexer and communications control connected to the multiplex channel with the aid of an integrated data transmission adapter.

The capacity of the model and its I/O permeability make possible efficient use of the ES 1016 as an independent system and as a station in a computer net. The computer configuration makes possible the building up of local and remote systems and makes possible operation in the batch and conversational mode.

The computer serves as a basis for the following applications systems types:

- traditional data processing systems,
- scientific-technical design systems,
- enterprise information systems,
- database-control online systems, and
- general purpose instructional systems.

A rich variety of user program packages is available for the user in the RPG, COBOL, FORTRAN and PL/I languages.

The Computer Technology Coordination Institute developed and sells the computer.

ES 1026 Universal Computer (Czechoslovakia, 1982)

The chief applications areas of the ES 1026 extend primarily to those statistical, financial and insurance institutions in which they solve business, planning, data processing or mathematical modelling tasks. Our journal described the structure, technical parameters and functional possibilities of the machine in 1982.

ES 5527 Magnetic Tape Store Control Equipment (Bulgaria, 1983)

This provides control of magnetic tape units with a high writing density-- 63 bits/mm (phase coded--FK) and 246 bits/mm (group coded--CSK)--in ESR 2 computer systems. The types of stores which can be controlled are:

- ES 5026 (2 m/s tape speed, FK/CSK);
- ES 5027 (e m/s tape speed, FK/CSK); and
- ES 5028 (5 m/s tape speed; FK/CSK development not yet completed).

Subsystems consisting of the control and the listed stores connected to it in any combination, possibly of various speeds, are functionally compatible with IBM 3803-2/3420-4, 6, 8 and Memorex 3222/3226, 3228 equipment.

The ES 5527/ES5026, ES 5027, ES 5028 magnetic tape subsystems can consist of one or two controls and a maximum of 16 tape units. In the case of one control a maximum of 8 tape units can be connected (1 x 8 configuration), while 16 tape units can be connected to 2 controls (2 x 16 configuration). In this case the second 8 tape units can be accessed from one of the controls via the other. Both controls of the 2 x 16 configuration can be connected to one channel too. In the case of connection to two channels the channel switching is program controlled. The channels can be selector or block multiplex channels, and can operate in the burst or block multiplex mode.

In the case of a writing density of 246 bits/mm the control corrects errors automatically if they appear in one or two bands of the tape. In the case of a writing density of 63 bits/mm only errors appearing in one of the bands can be corrected automatically.

In the case of writing/reading on one tape unit the control executes instructions--reeling, reeling and loading, erasing--independent of one another to the end of the tape.

It is possible to read the tape in both directions--forward and backward. When reading backward the data enter the channel in the order of reading--thus turned around. Data transmission speed toward the channel is a maximum of 1,230 K bytes per second (5 m/s, CSK) and the MTBF is 1,500 operating hours.

The table shows the technical characteristics of the magnetic tape stores which can be connected.

<u>Characteristic</u>	<u>ES 5026</u>	<u>ES 5027</u>	<u>ES 5028</u>
1. Tape speed (m/s)	2	3	5
2. Data transmission speed (K bytes/s) (FK/CSK)	126/712	189/738	315/1,230
3. Reeling time (s)	70	60	45
4. Tape loading	automatic	automatic	automatic
5. MTBF	750	750	1,000
6. Capacity (M bytes)	40/150	40/150	40/150
7. Writing density (bits/mm) (FK/CSK)	63/246	63/246	63/246

ES 9005 Multiple Work Site Magnetic Tape Data Preparation System (Bulgaria, 1982)

This is an efficient, multiple work site, specialized data collection and data processing system. It provides for data input, checking and preliminary data

processing, after which the data generally go to a large capacity computer for further processing. Various telecommunications modes can be used for data traffic. The system can be used in computer centers and in various data preparation centers.

The ES 9005 makes possible independent data input from 32 work sites, with which it provides a maximum of six service functions at the same time.

The advantages of the system:

- fast and efficient processor and use of a large capacity operational memory and external store;
- possibility of direct connection with the computer or with another ES 9005 (or ES 9003);
- efficient checking of information input;
- use of high level languages serving to facilitate and accelerate operator's work, which ensures rich possibilities for arithmetic and logical checking of data processing.

The system consists of the following hardware components:

- 16 bit microprogrammed processor (IZOT 2104);
- 248 K semiconductor operational memory (IZOT 3500);
- peripheral control block;
- one or two M byte magnetic disk stores (ES 5061);
- one or two magnetic tape stores (SM 5302) (9 band, 32 bit/mm writing density, 0.63 m/s tape speed, NRZ-I);
- operator's console (IZOT 0232);
- printer (mosaic printer ES 7168 or VT 27065);
- Latin or Cyrillic letter data input from a maximum of 32 terminals, with visual check possibility;
- data input through data input channel with aid of modems (600-9,600 bits/s).

In the data transmission mode data input takes place simultaneously independent from one another. Data input from any work site can be accessed (checked) from the other work sites. A maximum of 240 characters can be displayed at one time on the display.

Service information (16 characters) on the display aids the work of the machine operators. The machine operator can make contact with the system with the aid of functional keyboards. In the local mode the work sites can be a maximum of 600 meters from the processor. The magnetic disk background storage is the resident medium for the operating system. The remainder of the store can be divided into direct, sequential or index-sequential accessible areas according to the need of the user, on which the various libraries can be placed. The magnetic tape store serves for data input and output. During output the data can be regrouped and transformed in the desired code. The length of the output data blocks can be 16-9,999 bytes. The printer can be a return signal for the system console or it can be used as a system printer to print lists, forms, COBOL and RPG programs or reports written in the RPG language. In the data transmission mode the system operates according to the GSC algorithm in the speed range of 600-9,600 bits/s.

The system is controlled by the so-called "chief operator" from the SM-6312 system console. Libraries of forms and user programs written in the COBOL and RPG languages can be supported with the aid of suitable procedures.

A special operating system controls the ES 9005 system, making possible simultaneous execution of 38 tasks. The operating system is sold on magnetic tape with the possibility of generation for a configuration meeting concrete user needs.

ES 9114 Simplified Floppy Disk Data Preparation Equipment (Hungary, 1982)

With the aid of the equipment one can realize modern and convenient data preparation--forms produced by a program appear on the screen before the operator. With the program one cannot only select the given form, one can also take care of automatic filling out of fixed and repeated parts and the logical, arithmetic and syntactic correctness of the data. The auxiliary services of the screen facilitate to a significant degree data preparation and preliminary processing.

With the character generator one can produce Latin lower and upper case letters and national alphabets as needed in the case of foreign purchasers. A quasi-graphic character set serves to draw tables and aigrams. In the interest of facilitating the work of the machine operator, various forms of information highlighting (underlining, flashing, negative depiction) as well as inserting and erasing words and lines can be done on the screen. For editing of textual information entered, the screen can be divided into an optional number of subfields in which independent writing, erasing and correcting can be done. It is possible to prepare and load programs for local processing on the spot in the Assembly and BASIC languages. In addition to the standard user programs belonging to the basic set the Telephone Factory will prepare and deliver ad hoc programs according to user needs. The system is controlled by a micro-processor, which includes a maximum of 40 K bytes RAM and 24 K bytes PROM. The screen is of standard size--24 lines by 80 characters. Floppy disk storage with a capacity of 2 x 0.5 M bytes can be connected to the equipment. The keyboard used is alphanumeric, numeric and quasi-graphic, without functional connection.

If the user wants to use the equipment for processing requiring higher local intelligence, beyond data collection, the system can be expanded by virtue of its modular construction, and the peripheral units can be selected according to concrete needs. In this case--being used as an intelligent terminal--the equipment can be connected to a central computer via the available communications channels (telephone, telegraph, physical connection). In regard to its technical parameters and functional possibilities the Hungarian version of the equipment rises above the other two versions--the Bulgarian and the Czechoslovak.

8984
CSO: 2502/73

RECENT HUNGARIAN DEVELOPMENTS IN MINICOMPUTER SYSTEM

Budapest SZAMITASTECHNIKA in Hungarian Jun 84 p 4

/Unsigned article: "New Hungarian Developments in the MSR"/

/Text/ The MSR international testing of the SM-52/10-1 high performance mini-computer (MSR code number SM-1502) was completed successfully in November 1983 at the Videoton Developmental Institute.

The new computer belongs to the MSR second series and is a further development of the SM-52/10 minicomputer developed manufactured and proven well earlier.

The machine will be used primarily in the higher level of hierarchic automated control systems.

The chief applications areas are:

- automated control systems for technological processes;
- manufacturing technology preparation systems;
- production guidance and information collection systems;
- transaction handling systems;
- technical and scientific computation systems;
- design automation systems.

The SM 52/10-1 can function in two operating modes:

- in the first mode it provides compatibility with SM-4 type computers;
- in the second mode the machine operates as a further developed version of the ES 1011 computer.

The structure of the system can be called very rich compared to computers in the same category:

- a central unit with 1 M bytes storage;
- FORTRAN HW operator;
- COBOL HW operator;
- a builtin disk control unit for control of a maximum of 16 large capacity disks;
- SM-5302 magnetic tape storage;

- SM-5400 cassette magnetic disk storage;
- SM-5412 exchangeable magnetic disk storage (80 M bytes);
- ES 5076 fixed head magnetic disk storage;
- SM-5601 floppy disk storage;
- SM-6313, SM-6311 line printers;
- SM-6101 card reader;
- SM-7219 picture screen terminals;
- synchronous and asynchronous lines, and builtin microprocessor connectors for the peripherals listed.

In the first operating mode the SM-52/10-1 uses many user DOS (E-DOS) systems; in the second mode it can run basic software written in earlier years for the ES 1011.

A developed database management system and very many applications program packages are available for the SM-52/10-1 computer.

The international testing committee especially emphasized the following advantages of the SM-52/10-1 computer as compared to the SM-52/10 model:

a. Functional advantages:

- 1 M byte storage addressable in both operating modes of the machine;
- a FORTRAN operator;
- a COBOL operator;
- a builtin disk control unit to control large capacity disks;

b. Performance advantages:

- the access time to data files is decreased to one-half with the aid of the disk control unit;
- file access decreases to one-fifth with the aid of a disk control unit having cache memory;
- the execution time for tasks written in the COBOL language decreases to one-sixth;

c. Demonstrated during the testing were:

- an expanded version of E-DOS to handle 1 M byte storage;
- a dual access disk control unit which can handle two computers working with the same operating system.

8984

CSO: 2502/74

REMOTE DATA PROCESSING SYSTEM SOFTWARE IN HUNGARY

Budapest SZAMITASTECHNIKA in Hungarian Jun 84 p 11

/Article by Gabor Pados and Sandor Nagy: "Remote Data Processing System Software in Hungary, Part II, FQS and SSP"

/Text/ The FQS File Querying System

In the case of applications based on traditional file querying it would be very useful if we could write out not only the content of sequential and partitioned data files but also had a way to display directly the records of indexed sequential and virtual organization files. To the extent that such listings can be made not with batch processing auxiliary programs but rather with the aid of an online mode querying system ensuring immediate response time the checking of the operation of the applications programs would be simpler and more convenient and the process of development would be accelerated, and it might become unnecessary to write the simpler user programs of a query nature.

This service is provided by a small program product of a remote data processing program package acquired by the SZAFÁ /Computer Technology Applications Development Fund/ for computer centers equipped with ESR II computers and IBM 3270 or equivalent terminals--the FQS (Friendly Query System). The designation of the system refers to its easy and convenient use. No special computer technology knowledge is needed to use it; it is sufficient to have mastered operation of a 3270 terminal. With the aid of FQS a user authorized to do so can perform random queries in data files previously defined for the system. The result of the queries usually appears on a 3270 screen and if needed can be transferred to a 3280 terminal printer.

Operation

In essence FQS carries out transactions which can be run in a DOS/VS/E and OS/VS basic operating system under supervision of a SHADOW II or CICS/VS (1.4 and subsequent versions) remote data processing monitor. A computer in the ESR-II series is needed to run it.

FQS can attribute its fast operation, over and above the efficient use of resources, to the fact that it retains in a VSAM file arranged according to a

key definitions describing the users, the data files which can be queried, the distribution of their records, the queries preserved and the terminal-printers printing out the results. This, however, has a price in that the basic operating system must contain the VSAM service also.

The content of records of data files with standard DAM, ISAM and VSAM organization can be displayed with the aid of the FQS being sold. When the SHADOW II monitor is used the sphere of file types which can be accessed extends to those with sequential organization also, using the USAM access mode. If necessary one can also access database management systems and data files with nonstandard access modes by using user exit routines from FQS.

The system keeps a record of every user which contains the user's name, his codeword, his sphere of possible activity and the files which can be queried by him. The system also keeps a record of the entire range of files which can be accessed and of the distribution of every file record type. The defining of FQS users, files, file records and printers takes place online via the screen.

Use

Use of the FQS file query system is simple because the notations appearing on the screen always inform the user about the momentary phase of the query and about possible ways of continuing the query. If the user loses confidence anyway or is still inexperienced in use of the system then, at any time, in any phase of the query process, he can ask for detailed information. The text providing the information appears on the screen, but upon returning from the informational subsystem he can continue the query or processing from the same place where he broke off.

In the beginning of the query process one must select the file to be queried and the fields of the file records to be displayed. If we are interested in the content of every record then a listing begins after a brief preparation. If we want to make the display of individual records a function of the value of certain fields then we can set conditions--for at most 10 fields. In this case only those records appear the corresponding fields of which satisfy the given conditions in the course of a value test.

The listing of records can be terminated whenever the screen is full. Because of the space occupied by informative text, explanations and field headings, at most 10 records can be displayed on the screen at one time. In the pauses of the listing one can page backward and forward in the information displayed thus far.

After all records are written out the user can preserve the query command chain under a name given by him, can repeat the query in the same file according to old or new viewpoints, can initiate a new query in another data file or can request the printout on the terminal printer of the information which appeared in the course of the preceding query. After completion of the queries the user can log out of FQS and return under supervision of the remote data processing monitor.

The preserved queries can be referred to under the given name in the future, and they can be repeated at any time. This simple and convenient possibility for reproducing queries makes FQS suitable for realization of query functions for the most varied record keeping tasks.

The SHADOW II Modelling System

The majority of the ESR computers in use in Hungary today have small or medium size operational storage. Optimal utilization of this restricted storage capacity is a fundamental interest of every operator, which poses no small demands in regard to the size and efficiency of the program products used. All this is especially true in the case of the remote data processing monitor, since the database management system must operate simultaneously with this in the machine, which may also have to carry out batch processing. The creation of a remote data processing system is significant from the viewpoint of both the time and material resources expended and the decisions made in the course of this (the remote data processing monitor used, the structure of the data files, development of the applications program system, the remote data processing hardware devices used, type of terminals, the method of connecting them, etc.) greatly influence the memory requirement of the finished system and the efficiency of the use of the available resources. So an auxiliary tool with the aid of which we could quickly and cheaply develop a veritable model of the system being planned or models of possible versions of the system would be of great significance. Then, on the basis of tests conducted on these, we could design and create the necessary remote data processing system the size and operational efficiency of which would be known in the course of development.

This is provided by the SHADOW II modeling system (SMR) or the SHADOW II System Predictor (SSP). This is a modeling and performance measuring software tool which makes possible the study and evaluation of the operation of remote processing systems using the SHADOW II remote data processing monitor and the effect of changes made to it. The subject of studies made with the aid of the SMR could be the following:

- the operation of an entirely new remote data processing system,
- the effect of connecting new terminals to an existing system,
- phenomena produced by expanding or modifying existing applications,
- the effect of using various access methods (for example, switching from ISAM to use of VSAM),
- the effect of local or remote connection of terminals or of various line speeds used in the case of remote connection.

Operation of the SMR

In the course of preparing operation of the SMR, one determines the input characteristics of the system with macro-instructions given parameters in accordance with the use. We can divide these into four main groups: the remote data processing monitor, the remote data processing net, the data files and the user programs (transactions). The remote data processing monitor is the SHADOW II in every case, but execution of the model can take place under control of a real SHADOW II remote data processing system (one in use) or a SHADOW II

monitor created especially for this purpose. When defining the network we set down the characteristics of the terminals to be modeled and of the lines serving them and, in the course of modeling, the name and frequency of the transactions to be initiated from the terminals. When defining the data we describe the organizational type and size of the files used by the model system. We also produce the models of the user programs with a series of special macro-instructions. After starting up the model system thus created we first create the designated test data files and then begin execution of the transactions according to the definition. With the completion of the modeling time period also established as a parameter the SMR ends its operation and details, in the form of tables and histograms, the following system characteristics, according to transaction, measured during the run:

- average central unit time used,
- complete and average number of file I/O operations executed,
- complete and average processing time,
- average and longest response time for data exchanges executed,
- average bit number transmitted and received in the course of data exchanges.

In addition it displays status reports and statistics developed by the SHADOW II, from which we can get additional information pertaining to the demand on resources.

It can be useful to prepare models not only of remote data processing systems being planned but also of systems already operating. This makes it possible to tune and make final adjustments on the system without causing disturbances in the actual system (which may already be in use). It is a further advantage that in this way the entire tuning process can be done in a fraction of the time needed to tune a real live system. Another advantage is that the tuning takes substantially less time than if we did it on a live system.

Use

Operation of the SMR presumes a 3.0 level (OS or DOS) SHADOW II system in operation. The SMR makes possible use of the VSAM, ISAM or USAM access modes. In the case of use of VSAM and ISAM, the system aids the read, write and search operations. By using USAM one can also model use of the BDAM and SAM access modes. There is a possibility in the model system for creating and using a storage sequence (DISKQ) placed on disk. The SMR produces the model programs in the COBOL language, at the source code level, so the user can easily insert any instruction pertaining to a database management system--which can be used by the SHADOW II system.

8984

CSO: 2502/74

BRIEFS

ROBOTS IN OPERATION--About 50 robots are in operation in our homeland today. The majority of them turn out workpieces, 20 percent of them are welding robots, but there are a few painting and 1 or 2 assembly robots too. The Ministry of Industry and the OMFB National Technical Development Committee has issued a joint competition for use of robots within the framework of which 22 enterprises received central support last year covering almost half of the costs to put a total of 27 robots into operation. According to the plans another 30-40 robots will be placed into operation this year, about 50 in 1985, and in the future they count on placing 50-80 into operation each year. Text Budapest SZAMITASTECHNIKA in Hungarian Jun 84 p 14/ 8984

ORION GRAPHIC DISPLAY--The Orion Radio and Electric Enterprise is working on starting manufacture of a color graphic display. Plans are to reach zero series manufacture of the OCD-500 device this year. In future work also there will be close cooperation with the Process Control Faculty of the Budapest Technical University, where the OCD-500 was developed. The planned display has 512 x 512 pixels, one can select from 64 colors and 16 colors can be displayed on the screen simultaneously. In addition, Orion participated successfully in the Leipzig Fair this year; they signed a contract with the GDR partner to deliver 600 modems by 1985. Text Budapest SZAMITASTECHNIKA in Hungarian Jun 84 p 14/ 8984

DATA COOP ACHIEVEMENTS--The Datacoop computer technology small cooperative has achieved significant results since its formation on 1 July 1982. Memory expansions produced by it have increased the performance of computers for 17 of the domestic users operating ESR computers. As a result they have achieved more efficient multiprogrammed operations, have decreased running times, have increased the efficiency of resources, the availability of machines and the reliability of their hardware and have simplified programming. In connection with another development it became possible to realize direct or remote connection of Orion and Videoton picture screen displays to ESR computers. With the aid of the display control unit of Datacoop a maximum of 16 picture screen devices can be connected to the multiplex channel of the computers. The ADP 2000, ADP 2052, VDT 52101 and VDT 52104 devices connected to computers on the basis of the development are IBM compatible from the direction of the ESR computers. The users include the Godollo Agricultural Sciences University, the Telecommunications Research Institute and the Western Hungary Wood Combine. The newest product of the small cooperative is the DCD-PRT-80 matrix printer, for which they have already received 500 orders. Interest in the equipment is very great both domestically and internationally (socialist and capitalist countries). Text Budapest SZAMITASTECHNIKA in Hungarian Jun 84 p 14/ 8984

ECOLOGICALLY THREATENED AREAS DESCRIBED

Water, Air Pollution, Control

Warsaw WIADOMOSCI STATYSTYCZNE in Polish No 5, May 84 pp 32-35

[Article by Stefania Rola-Kunach, Department of Information and Analysis, State Statistical Office: "Ecologically Endangered Areas in Poland in 1982: II. Environment Hazards and Protection. Water and Air."]

[Text] Analyzing the causes of pollution and destruction of man's natural environment in a general framework, at least three groups of destructive factors are identified:

- surface and ground water and also soil and land pollution by urban and industrial sewage;
- atmospheric air contamination by dust and by gases, mainly through fuel combustion;
- changes of the terrain topography and hydrologic conditions, often caused by immediate devastation of soil cover, mainly through industrial activities.

Limited water reserves of Poland and their limited availability associated with uneven spatial distribution and increased water consumption by the economy, on the one hand, and the increased quantity of effluents, especially untreated waste water discharged mainly to surface water, on the other, urge towards management of water reserves.

Industry is the principal consumer of water reserves; it utilizes mainly surface and ground waters, as well as certain amounts of water from utilities networks.

A major factor in industrial water consumption is large enterprises with an annual consumption of over 40,000 m³ (more than 100 m³ per day). In 1982, the ecologically endangered regions* contained 1,474 such enterprises (of a national total of 3634). They utilized 6.9 billion m³ of water (as compared

*The ecologically endangered regions have been described in an article by J. Wojtan, "Ecologically Endangered Regions in Poland" (I), WIADOMOSCI STATYSTYCZNE No 4, 1984, Warsaw, State Statistical Office.

Table 1. Water Use in the National Economy in 1982 (in million m³)

Area	Industry ^a				Communal utilities ^c	
	Total	Subtotal	Including production use from communal utilities	Farming and forestry ^b	Subtotal	Including households
Poland	14552.3	10373.4	296.7	1768.2	2410.7	1437.5
Ecologically threatened regions	8601.1	6935.9	195.6	257.8	1407.4	844.4
Belchatow	16.2	15.0	-	1.2	-	-
Biale Zagłębie	32.0	9.3	2.1	2.9	19.8	12.5
Bydgoszcz-Torun	153.7	72.0	18.1	1.9	79.8	41.8
Chelm	21.3	8.0	0.2	8.6	4.7	3.2
Czestochowa	65.4	36.9	4.3	0.1	28.4	15.6
Gdansk	284.6	125.8	7.7	56.1	102.7	69.0
Upper Silesia	1013.7	509.0	76.6	24.0	480.7	289.4
Inowroclaw	111.0	101.2	0.7	0.5	9.3	5.4
Jelenia Gora	45.5	24.0	0.8	6.1	15.4	9.4
Konin	1602.1	1538.0	0.8	57.5	6.6	4.5
Krakow	888.7	788.4	8.1	13.3	87.0	48.2
Legnica-Glogow	135.9	72.1	3.6	23.5	40.3	27.5
Lodz	197.3	70.3	29.3	2.7	124.3	72.7
Myszkow-Zawiercie	25.5	16.0	1.7	0.3	9.2	5.5
Opole	109.6	82.4	2.0	0.2	27.0	17.1
Plock	52.9	42.6	0.6	-	10.3	7.2
Poznan	105.5	36.5	9.8	1.4	67.6	39.2
Pulawy	128.8	119.5	0.1	3.5	5.8	3.8
Rybnik	113.5	54.1	7.2	7.7	51.7	25.0
Szczecin	1918.3	1828.0	3.8	16.9	73.4	45.5
Tarnobrzeg	1082.8	1054.4	2.4	10.5	17.9	10.8
Tarnow	103.3	76.7	5.8	3.8	22.8	11.6
Tomaszow	40.9	34.2	0.6	0.6	6.1	3.6
Turosz	50.3	40.8	1.0	0.5	9.0	4.3
Walbrzych	44.1	19.9	1.9	-	24.2	15.6
Wloclawek	127.8	101.4	2.1	13.8	12.6	7.8
Wroclaw	130.4	59.4	4.3	0.2	70.8	48.2
Other areas	5951.2	3437.5	101.1	1510.4	1003.3	593.1

^aEnterprises using water or discharging waste water in amounts of at least 40,000 m³/year.

^bIrrigation and fish pond maintenance; without irrigation by waste water.

^cWater supplied to consumers by communal utilities.

with the national figure of 10.4 billion m³), i.e., 81 percent of total water consumption in the national economy of these regions. The concentration of this great number of industrial enterprises using almost 67 percent of the entire industrial consumption of the nation in this limited territory is a negative phenomenon, causing, in particular, disruptions of water balances and resulting in unfavorable long-term environmental changes.

Effects of industrial activities on water environment are due not only to the great number of enterprises but also to the water-intensiveness and types of production. These factors determine the quantity of water utilized by the industry, as well as the quality and degree of pollution of industrial effluents.

The following regions had the largest share of industrial water consumption: Szczecin (17.6 percent of the national figure), Konin (14.8 percent) and Tarnobrzeg (10.2 percent), mainly because of the concentration here of electric power plants.

The regional concentration of water-intensive industries is characterized by water consumption per km². Water consumption per km² was the highest in the following regions: Konin (1.52 million m³), Szczecin (525,000 m³), Tarnobrzeg (413,000 m³) and Krakow (334,000 m³).

Water consumption by utilities has been increasing. They consume more than 16 percent of the total water consumption in the ecologically endangered regions.

Agriculture and forestry are the third largest water consumer after industry and utilities. But their share of water use in these areas did not exceed 3 percent. The current situation with water supplies in the countryside fails to meet even the current demands, not to mention projected requirements. With advancing intensification of farming, water becomes an indispensable element for raising the crop production (sprinklers), livestock breeding output and general level of sanitation and hygiene in the villages.

Total water use and consumption by industry has a direct effect on the quality of discharged waste water. In 1982, industrial enterprises localized on ecologically endangered regions (using at least 40,000 m³ of water annually) discharged about 7 billion m³ of effluents (67.7 percent of the national total industrial waste water). The bulk of industrial effluents were discharged into surface water: 6.7 billion m³, including 5.1 billion m³ of coolant water, which is considered nominally to be clean. These waters, however, are warm, and when large amounts of them are discharged into surface water having a low flow rate or into stagnant waters, they cause so-called thermal contamination of reservoirs, with damaging effects to the water environment. In addition, over 1.3 billion m³ of urban sewage was discharged into surface water. Altogether, from the ecologically endangered regions, 8 billion m³ of industrial and sewage water was discharged into surface water (compared with the national total of 12.1 billion m³), including 3 billion m³ of waste water requiring treatment. Of this quantity, 1.7 billion m³ of waste water was

Table 2. Industrial and Commercial Waste Discharged into Surface Waters in 1982 (millions of m³)

Area	Including water requiring treatment																	
	Total																	
	Directly from industrial enterprises ^a				By urban sewage				Treated ^b				Discharged				% of amount requiring treatment	
	Total	Subtotal	Including coolant waters	By urban sewage	Total	Subtotal	Mechanically	Chemically	Biologically	Subtotal	Directly from industrial enterprises	Through urban sewage	Total in thousand m ³ per km ²	15	16			
1	2	3	4	5	6	7	8	9	10	11	12	13	14	15	16			
Poland	12141.8	9762.5	7544.6	2379.3	4597.2	2597.5	1689.3	169.8	738.4	1999.7	719.8	1279.9	14.7	16.1	43.5			
Ecologically endangered areas	8047.6	6709.3	5087.7	1338.3	2959.9	1723.1	1190.5	135.1	397.5	1236.8	508.8	728.0	84.0	13.4	41.8			
Belchatow	3.8	3.8	-	-	3.8	3.8	3.3	-	0.5	-	-	-	17.0	11.3	-			
Biale Zaglenie	29.4	5.9	-	23.5	29.4	17.3	1.3	-	16.0	12.1	4.5	7.6	28.4	54.3	41.3			
Bydgoszcz-Torun	122.0	45.5	9.1	76.5	112.9	19.1	6.3	2.6	10.2	93.8	28.3	65.5	59.2	8.9	83.1			
Chekm	11.1	5.9	-	5.2	11.1	10.3	4.5	-	5.8	0.8	0.8	-	7.6	51.6	7.5			
Czestochowa	51.4	26.6	0.4	24.8	51.0	39.0	13.8	0.0	25.2	12.0	12.0	-	125.5	49.3	23.5			
Gdansk	202.0	99.9	83.8	102.1	118.2	92.3	66.0	3.0	23.3	23.9	0.5	25.4	36.7	19.7	21.9			
Upper Silesia	974.3	570.6	69.1	403.7	905.2	495.0	407.4	21.1	66.5	410.2	154.7	255.5	288.8	7.4	45.3			
Inowroclaw	96.2	88.1	74.3	8.1	21.9	13.5	12.8	-	0.7	8.4	0.3	8.1	28.7	2.9	38.8			
Jelenia Gora	34.0	19.6	1.1	14.4	32.9	22.9	12.5	9.0	1.4	10.0	1.5	8.5	62.0	4.3	30.4			
Konin	1646.8	1638.4	1516.7	8.4	130.1	128.1	124.5	-	3.6	2.0	1.6	0.4	128.6	2.8	1.5			
Krakow	829.1	738.8	519.6	90.3	309.5	49.0	41.6	0.1	7.3	260.5	216.8	43.7	131.2	2.4	84.2			
Legnica-Glogow	90.0	49.2	0.0	40.8	90.0	75.4	42.2	13.3	19.9	14.6	11.1	3.5	22.3	22.2	16.2			
Lodz	156.9	12.2	-	144.7	156.9	7.7	0.4	7.1	0.2	149.2	4.5	144.7	190.1	0.1	95.1			
Myszkow	17.2	9.5	0.8	7.7	16.4	14.9	7.8	0.2	6.9	1.5	0.8	0.7	80.4	42.1	9.1			
Zawiercie	113.2	86.1	0.9	27.1	112.3	90.1	78.1	0.0	12.0	22.2	20.8	1.4	111.8	10.7	19.7			
Opole	46.4	35.4	0.0	11.0	46.4	45.8	1.8	-	44.0	0.6	0.5	0.1	183.9	94.9	1.3			
Plock	84.2	14.3	2.3	69.9	81.9	33.2	25.7	5.8	1.7	48.7	1.9	46.8	82.0	2.1	59.5			
Poznan	95.6	88.2	78.0	7.4	17.6	17.1	4.8	4.8	7.5	0.5	-	0.5	23.8	42.4	2.7			
Pulawy	64.8	36.7	0.5	28.1	64.3	46.4	25.1	1.0	20.3	17.9	8.6	9.3	62.0	31.5	27.9			
Rybnik	1881.7	1797.7	1735.0	84.0	146.7	77.1	52.0	37.5	7.1	69.6	5.5	64.1	42.1	4.8	47.5			
Szczecin	1094.4	1079.7	919.8	14.7	174.6	164.0	159.0	1.8	3.2	10.6	1.7	8.9	68.5	1.9	6.1			
Tarnobrzeg	77.4	59.1	9.5	18.3	67.9	47.7	31.6	0.2	15.9	20.2	5.5	14.7	61.0	23.5	29.8			
Tarnow	37.9	30.5	10.0	7.4	27.9	27.9	0.9	19.2	7.8	-	-	-	57.1	28.0	-			
Tomaszow	31.3	25.2	2.9	6.1	28.4	27.3	21.2	1.3	4.8	1.1	0.9	0.2	66.9	16.9	3.9			
Turosz	41.4	19.3	-	22.1	41.4	30.2	16.4	-	13.8	11.2	9.5	1.7	84.1	33.3	27.1			
Walbrzych	97.8	83.1	44.6	14.7	53.2	28.5	22.2	6.0	0.3	24.7	10.0	14.7	84.8	0.6	46.4			
Wloclawek	117.3	40.0	9.3	77.3	108.0	99.5	26.8	1.1	71.6	8.5	6.5	2.0	119.9	66.3	7.9			
Wroclaw	4094.2	3053.2	2456.9	1041.0	1637.3	874.4	498.8	34.7	340.9	762.9	211.0	551.9	5.9	20.8	46.6			

^a Together with contaminated mine waters; data also include coolants from electric power plants operating on brown coal (in 1982, 1515.4 million m³).

^b Treatment installations of industrial enterprises and communal utilities.

treated, while the remaining volume of about 1.3 billion m³ of effluents (62 percent of the national total of untreated waste water) was discharged into surface water without any treatment. This situation, which puts at risk the purity of surface water of the entire nation, has been particularly acute in the following regions: Upper Silesia (410.2 billion [as published] m³ untreated waste water), Krakow (260.5 million m³) and Lodz (149.2 million m³). Altogether, about 41 percent of the national total volume of untreated waste water was concentrated in these areas. In Upper Silesia and Lodz, the larger portion of the effluents consisted of urban sewage.

Untreated (industrial and residential) effluents, related to the total volume of effluents requiring treatment, in the ecologically endangered areas accounted for 42 percent of the total (compared with the national figure of 44 percent). Individual areas showed large variations. The situation was good in Tomaszow and Belchatow, where 100 percent of the effluents subject to treatment were indeed treated. In the Lodz, Krakow and Bydgoszcz-Torun areas, the treated volumes constituted a small portion of the amounts requiring treatment (4.9, 15.8 and 16.9 percent, respectively).

About 70 percent of treated waste water in the ecologically endangered regions was treated by purely mechanical means. Therefore, the resulting reduction of pollution was unsatisfactory. Biologically treated effluents (the highest degree of water purification) accounted hardly for 23 percent of the total amount of treated waste water in these regions.

A major problem in environmental protection is atmospheric pollution by toxic liquids and gases. The principal sources of potential air pollution are: burning of coal and liquid fuel by industry and households, automobiles and railroad transport, and byproducts of chemical plants, metal furnaces and mines.

Aside from the fact that large amounts of valuable chemical compounds and rare metals are wasted, emission of pollutants into the air disrupts biological balances and eventually endangers human health and life. Atmospheric air pollution, in addition, causes losses of timber stands and crops and also losses due to corrosion of metal roofs and steel structures.

The data in this paper cover 582 industrial enterprises (including power production) recognized as particularly damaging to the environment.

Of the dust pollutants, one should mention first of all ash, cement, metallurgical dust, dust from fertilizer plants and others. Volatile ashes account for almost three-quarters of dust pollution, and in some of the ecologically endangered areas even 100 percent (Belchatow, Jelenia Gora, Tomaszow and Turosz).

The highest levels of dust emission per km² in 1982 were observed in the following regions: Turosz (275.4 tons), Myszkow-Zawiercie (163.7 tons) and Upper Silesia (140.5 tons); the average for the ecologically endangered regions was 41 tons/year per km², compared with the national average of 5.9 tons/year per km².

Table 3. Levels of Industrial Emission of Air Pollutants in 1982^a

Area	Emission of pollutants (per km ² in tons)					
	Dust and gas total	Dust		Gas		
		Sub- total	Including ash	Sub- total	Including sulfur dioxide	Including carbon monoxide
Poland	21.2	5.9	4.4	15.2	7.8	4.8
Ecologically endangered areas	155.1 ^a	41.0	30.2	114.1	56.4	39.1
Belchatow	133.5	18.1	18.1	115.4	93.2	-
Biale Zaglenie	58.1	45.7	0.4	12.4	4.0	3.8
Bydgoszcz-Torun	33.2	13.2	12.6	20.0	13.7	0.2
Chelm	30.0	27.4	0.8	2.6	2.6	-
Czestochowa	249.3	89.9	14.0	159.4	39.2	89.6
Gdansk	26.4	9.9	8.8	16.5	13.8	0.2
Upper Silesia	601.8	140.5	108.9	461.3	192.9	184.9
Inowroclaw	59.6	33.1	28.8	26.5	16.2	5.2
Jelenia Gora	19.7	4.5	4.5	15.2	4.1	0.2
Konin	225.0	85.1	81.7	139.9	139.8	-
Krakow	282.6	46.2	26.6	236.4	51.1	154.9
Legnica-Glogow	93.4	7.2	2.3	86.2	21.7	63.2
Lodz	101.5	38.2	37.1	63.3	58.4	0.2
Myszkow-Zawiercie	263.2	163.7	12.2	99.5	23.0	58.8
Opole	269.9	85.9	51.9	184.0	59.1	72.1
Plock	482.9	4.3	0.4	478.6	280.9	15.1
Poznan	28.1	10.4	8.7	17.7	11.1	5.3
Pulawy	53.8	15.9	9.4	37.9	15.9	-
Rybnik	269.8	59.1	53.4	210.7	170.9	8.9
Szczecin	60.2	10.0	9.3	50.2	37.0	4.2
Tarnobrzeg	98.4	33.7	33.3	64.7	64.0	0.1
Tarnow	37.5	11.9	11.3	25.6	7.5	5.6
Tomaszow	72.8	14.2	14.2	58.6	31.0	1.7
Turosz	637.6	275.4	275.4	362.2	318.2	-
Walbrzych	70.1	30.1	26.0	40.0	17.5	7.3
Wloclawek	25.8	6.2	5.7	19.6	14.0	0.6
Wroclaw	96.4	40.9	38.2	55.5	32.5	5.0
Other areas	4.2	1.5	1.1	2.7	1.6	0.4

^aDuring the year.

Table 4. Industrial Pollution and Protection of Atmospheric Air in 1982

Area	Emission of pollutants (thousand tons)				Pollution captured by emission-control installations					
	Dust		Gas		Dust		Gas			
	Dust and gas total	Sub-total	Including ash	Sub-total	Including sulfur dioxide	Including carbon monoxide	Thousands of tons	% of pollutants produced		
Poland	6621.3	1859.9	1367.8	4761.4	2433.1	1496.1	23652.9	92.7	613.0	11.5
Ecologically endangered areas	5463.5	1446.0	1064.8	4017.5	1986.7	1378.3	19479.1	93.1	595.3	13.0
Belchatow	29.5	4.0	4.0	25.5	20.6	-	180.1	97.8	-	-
Biale Zaglebie	60.0	47.2	0.4	12.8	4.1	3.9	740.1	94.0	-	-
Bydgoszcz-Torun	63.3	25.2	24.1	38.1	26.2	0.3	159.8	86.4	12.0	23.9
Cheim	43.7	39.9	1.1	3.8	3.8	-	49.0	55.2	-	-
Czestochowa	101.2	36.5	5.7	64.7	15.9	36.4	139.8	79.3	-	-
Gdansk	85.1	31.9	28.3	53.2	44.6	0.5	208.3	86.7	8.8	14.2
Upper Silesia	1886.0	440.4	341.3	1445.6	604.6	579.6	4416.3	90.9	166.3	10.3
Inowroclaw	45.5	25.3	22.0	20.2	12.4	4.0	155.7	86.0	0.0	0.2
Jelenia Gora	10.5	2.4	2.4	8.1	2.2	0.1	6.0	71.9	0.0	0.1
Konin	227.7	86.1	82.7	141.6	141.5	-	1020.9	92.2	1.1	0.8
Krakow	667.0	109.0	62.7	558.0	120.5	365.6	990.3	90.1	2.8	0.5
Legnica-Glogow	376.5	28.8	9.3	347.7	87.6	254.7	304.1	91.4	270.4	43.8
Lodz	83.7	31.5	30.6	52.2	48.2	0.2	255.3	89.0	1.7	3.1
Myszkow-Zawiercie	53.7	33.4	2.5	20.3	4.7	12.0	24.0	41.9	0.1	0.4
Opole	271.2	86.3	52.2	184.9	59.4	72.5	1635.7	95.0	20.2	9.8
Plock	121.7	1.1	0.1	120.6	70.8	3.8	1.4	55.9	40.2	25.0
Poznan	28.1	10.4	8.7	17.7	11.1	5.3	27.0	72.2	2.0	14.1
Pulawy	39.9	11.8	7.0	28.1	11.8	-	129.2	91.6	5.3	15.9
Rybnik	280.1	61.4	55.4	218.7	177.4	9.2	1808.9	96.7	-	-
Szczecin	209.6	34.9	32.3	174.7	129.0	14.6	1312.2	97.4	26.6	13.2
Tarnobrzeg	251.1	86.1	85.0	165.0	163.2	0.2	1762.3	95.3	3.3	2.0
Tarnow	41.7	13.2	12.6	28.5	8.4	6.2	187.8	93.4	11.5	28.8
Tomaszow	30.3	5.9	5.9	24.4	12.9	0.7	8.3	58.4	3.3	12.0
Turosz	318.8	137.7	137.7	181.1	159.1	-	3672.3	96.4	-	-
Walbrzych	34.5	14.8	12.8	19.7	8.6	3.6	44.8	75.1	0.3	1.6
Wloclawek	16.2	3.9	3.6	12.3	8.8	0.4	7.5	66.1	0.0	0.0
Wroclaw	86.9	36.9	34.4	50.0	29.3	4.5	232.0	86.3	18.5	27.0
Other areas	1157.8	413.9	303.0	743.9	446.4	117.8	4173.8	91.0	17.7	2.3

Relative to the national emission level for 1982, the highest levels of dust emission were observed in the following regions: Upper Silesia (23.7 percent), Turosz (7.4 percent), Krakow (5.9 percent), as well as Konin, Opole and Tarnobrzeg (4.6 percent each).

As regards the quantities and fast dissemination in the environment, particularly dangerous to man are toxic gases emitted into the atmosphere. The principal gas pollutants are: sulfur dioxide and carbon monoxide (49.4 percent and 34.3 percent of gas pollution, respectively, in the ecologically threatened regions), as well as nitrous oxide, hydrogen sulfide, carbon disulfide, compounds of fluorine, hydrocarbons and others.

Excessive emissions of sulfur dioxide are a crucial issue in air protection. The emission of this substance was particularly high in 1982 in the following regions (per km²): Turosz (318.2 tons), Plock (280.9 tons), Upper Silesia (192.9 tons), Rybnik (170.9 tons) and Konin (139.8 tons), as compared with the national average of 7.8 tons.

Industrial enterprises located on ecologically threatened areas emit into the atmosphere 84.4 percent of the total industrial emissions of gas pollutants in the nation. Of this, as much as 30.4 percent is the share of Upper Silesia, 11.7 percent Krakow and 7.3 percent the Legnica-Glogow area.

It should be emphasized that, technologically, the problem of protecting the air from dust has been resolved, and getting the problem under control in this area is now mainly a matter of producing dust-trapping devices and a proper operating system. In 1982, the ratio of reduction of dust emissions on ecologically threatened areas attained 93.1 percent. It should be added, however, that a considerable reduction of emissions compared with 1981 was due to curtailments of production. In many regions, however, the ratio of trapped dust to total pollutants is still low. For instance, in the regions of Myszkow-Zawiercie, Chelm, Plock and Tomaszow it varies from 40 to 60 percent. The situation with gas emissions remains much worse, especially as regards toxic gases, where even small concentrations cause major economic and health hazards.

In 1982, just 13 percent of the total gas pollutants emitted by industrial enterprises were trapped in the ecologically threatened regions. The indicator was especially low in the Krakow region. Industrial enterprises in the Krakow area emit as much as 11.7 percent of the total gas pollutants in the nation, and only 0.5 percent of this amount was captured by emission-control installations. The highest level of gas emission reduction in 1982 was attained by industrial enterprises in Legnica-Glogow: 43.8 percent.

The reason for the particularly unfavorable situation as regards gas emissions is the nonexistence of domestic gas treatment technologies, combined with the high cost of imported equipment. A major factor in air pollution, especially by sulfur compounds, are sources of emission located outside the nation's borders.

Pollution From Neighboring Countries

Warsaw RZECZPOSPOLITA in Polish 26 Apr 84 p 4

[Article by (z): "Trees Die Standing; An Unhappy Record; 'Green Lungs' Require Therapy; What Happened in the Izerian Mountains?"]

[Text] Another sad record has been set by our nation: Poland has advanced to first place in Europe and in the world as regards atmospheric air pollution. In the past six years, the emission of gas pollutants increased by almost 60 percent. Every substance dangerous to man can be found in the air over Poland.

Not all of this pollution is domestic in origin. About 50 percent comes from neighboring nations. However, the remaining 50 percent of gas and dust emissions result from noncompliance with the laws about environmental protection and maintenance passed in 1980. According to these ordinances, 1066 enterprises especially hazardous to the atmosphere are required to reduce pollution levels. Only 140 of them currently have dust trapping installations, and about 100 have equipment to reduce gas pollution.

The hazardous effects for human health are exacerbated by threats to the vegetable cover. The nation's so-called "green lungs" themselves must be saved. The zone of the critical level of hazardous emissions encompasses more than 60 percent of the nation's wooded territory. Over 500,000 hectares of coniferous forest are in a state of agony, including many of the national parks. The continuing growth of gas emissions may cause complete destruction of coniferous timber stands, which account for as much as 80 percent of forest reserves.

The fiercest foes of the forests are sulfur and nitrogen compounds, which cause acid rain over the entire breadth of Europe. They are also appearing over Poland. If concentration of sulfur dioxide in the atmosphere continues to grow, the destruction of forests will be inevitable and will be only a matter of time.

The speed of this process of destruction is illustrated by the Izerian Mountains. Just 10 years ago, tourist guidebooks wrote that this was an area of most beautiful fir forestation. In 1984, however, the entire mountain belt for several hundred square kilometers has not a single old fir tree, and the young seedlings tree die after two or three years. More and more birch trees are planted in the mountain, because birch is more resistant to atmospheric pollutants. This, however, means a total change of the vegetation in these mountains.

Unless radical steps are taken to protect the atmosphere, the current generation of trees in many of the nation's forests will be the last source of timber and paper raw materials available in Poland. In fact, all of the plights that might befall the forest (such as gypsy moths or hurricanes) are secondary compared to the major cause of forest debilitation—this poisoning by industrial emissions. The Institute of Farming and Forestry Studies has established a close correlation between atmospheric pollution, the condition of forest stands and their biological resistance to other natural hazards.

Lately, more than a dozen new dangerous species of insects and fungi have appeared in the weakened forests, which until now were only known in Poland from pictures in textbooks. Fighting these pests has now become an issue of primary importance.

Man has a better resistance than a tree, but without natural support of nature, his health is also in jeopardy. By saving forests, man saves himself. Too bad that he rarely remembers this.

9922

CSO: 2602/34

END