

JPRS-CST-90-028
9 NOVEMBER 1990



JPRS Report

Science & Technology

China

19980506 052

DISTRIBUTION STATEMENT A
Approved for public release;
Distribution Unlimited

REPRODUCED BY
U.S. DEPARTMENT OF COMMERCE
NATIONAL TECHNICAL INFORMATION SERVICE
SPRINGFIELD, VA. 22161

DMC QUALITY INSPECTED 3

Science & Technology China

JPRS-CST-90-028

CONTENTS

9 November 1990

ADVANCED MATERIALS

- PLT, BT Ceramic Thin Films Developed via Sol-Gel Technique
[HUAZHONG LIGONG DAXUE XUEBAO, No 4, Aug 90] 1

BIOTECHNOLOGY

- Studies on the 120MD Plasmid and Its Derivative Plasmid in Shigella Sonnei
[Liu Wei, Wang Bingrui; ZHONGHUA WEISHENGWUXUE HE MIANYIXUE ZAZHI, No 4, Aug 90] 2
- Study on Immunoprotective Effects of the Outer Membrane From Shigella Flexneri 2a
[Xu Xiaoping, Chu Lianrui, et al.; ZHONGHUA WEISHENGWUXUE HE MIANYIXUE ZAZHI, No 4, Aug 90] 2
- Purification of Autographa Californica Nuclear Polyhedrosis Virus DNA and Cloning of the Polyhedrin Gene
[Li Yiping, Xin Jihou, et al.; YICHUAN XUEBAO, No 4, Aug 90] 2
- Preliminary Application of Monoclonal Antibodies in the Analysis of Epitopes Present on the Outer Membrane of Shigella Flexneri 2a
[Zhang Weifen, Wu Xin, et al.; ZHONGHUA WEISHENGWUXUE HE MIANYIXUE ZAZHI, No 4, Aug 90] 2
- Establishment of CHO Cell Assay To Examine the Biological Activity of Edema Factor (EF) of Anthrax Toxin
[Nan Li, Hu Juan; ZHONGHUA WEISHENGWUXUE HE MIANYIXUE ZAZHI, No 4, Aug 90] 3
- Preparation and Analysis in Vitro of McAb-Adriamycin Immunoconjugate Against Human Glioma
[Hu Zhiqing, Yang Guizhen; ZHONGHUA WEISHENGWUXUE HE MIANYIXUE ZAZHI, No 4, Aug 90] 3
- A Single Amino Acid Substitution of $\alpha 1$ Interferon Changes Its Biological Activities
[Li Yan, Hou Yunde; ZHONGHUA WEISHENGWUXUE HE MIANYIXUE ZAZHI, No 4, Aug 90] 3
- The Study of Cytotoxic Factor Induced by Antiviral i-RNA
[Yang Mingjiu, Liu Beixing; ZHONGHUA WEISHENGWUXUE HE MIANYIXUE ZAZHI, No 4, Aug 90] 3
- Detection of HFRSV-Ag and Isolation of HFRSV From CSF of the Patients With Brain-Type HFRS
[Li Ge, Fang Liang, et al.; ZHONGHUA WEISHENGWUXUE HE MIANYIXUE ZAZHI, No 4, Aug 90] 4
- Antigenic Analysis of Chinese Strains of Spotted Fever Group Rickettsiae With Monoclonal Antibodies by Immunoblotting
[Yu Xuejie, Fan Mingyuan, et al.; ZHONGHUA WEISHENGWUXUE HE MIANYIXUE ZAZHI, No 4, Aug 90] 4
- Cytogenetic Effects of Attenuated Live Measles Vaccine on Male Mice
[Shi Qinghua, Shi Liming; YICHUAN XUEBAO, No 4, Aug 90] 4
- Studies of Chromosome G-Banding in Rice (Oryza sativa)
[Yao Qing, Song Yunchun, et al.; YICHUAN XUEBAO, No 4, Aug 90] 4
- The Construction of Shuttle Plasmid Vector of Streptomyces and E. coli
[Tan Huarong, He Song, et al.; YICHUAN XUEBAO, No 4, Aug 90] 5
- Construction of Promoter Probe Vector pFDC4 and Gene Expression Vector pFDC11 With High Transformation Efficiency in Bacillus stearothermophilus
[He Xiaosong, Shen Renquan, et al.; YICHUAN XUEBAO, No 4, Aug 90] 5
- Cloning and Expression of Parasporal Crystal Protein Gene of Bacillus Thuringiensis Var. Galleriae 81-6 Strain
[Wang Zhiyong, Wu Beihua; WEISHENGWU XUEBAO, No 4, Aug 90] 5
- Separation and Purification of the Toxic Protein of Bacillus Sphaericus Ts-1
[Yu Ziran, Shang Kejin, et al.; WEISHENGWU XUEBAO, No 4, Aug 90] 5
- A New Serotype of Shigella Boydii
[Yang Zhengshi, Hu Chaowen, et al.; WEISHENGWU XUEBAO, No 4, Aug 90] 6

Specific Monoclonal Antibodies to F41 Adhesin of Enterotoxigenic Escherichia Coli and Their Potential Uses as Diagnostic and Therapeutic Reagents [Yang Liang, Liu Xiufan; WEISHENGWU XUEBAO, No 4, Aug 90]	6
Predicting Carcinogens With Genetic Toxicology Tests: Role and Strategy [Zhou Zongcan, Fu Juanling, et al.; BEIJING YIKE DAXUE XUEBAO, No 4, Aug 90]	6
Embryonic Toxicity of Di-Ku-Shuang (Bis-A-TDA) on Drosophila Melanogaster and the Detoxication of Niacinamide [Zeng Fanya, Wang Fangyuan, et al.; SICHUAN DAXUE XUEBAO, No 3, Aug 90]	6
Synthesis of 4-(N-Substituted) Aminomethyl Phenylalanines [Liu Keliang, He Binglin, et al.; YINGYONG HUAXUE, No 4, Aug 90]	7
Glucose Biosensor Based on Cobalt Porphyrin Modified Glassy Carbon Electrode [Zhang Yonghua, Feng Lianyu; YINGYONG HUAXUE, No 4, Aug 90]	7
Expression of Human Interleukin 4 Fusion Protein in E. Coli With High Efficiency [Ma Dalong, Guo Shujun, et al.; BEIJING YIKE DAXUE XUEBAO, No 4, Aug 90]	7
Studies on R Plasmid From Multiresistant Salmonella Typhi [Huang Rui, Mu Rongpu; ZHONGHUA CHUANRANBING ZAZHI, Aug 90]	7
Influence of Ribaverin Upon Elimination of Urinary Electrolytes in Patients With Epidemic Hemorrhagic Fever [Guan Meiyang, Zhou Xinchun, et al; ZHONGHUA CHUANRANBING ZAZHI, Aug 90]	8
Study on the Sites of Epidemic Hemorrhagic Fever Virus Multiplication in a Fetus [Xu Xiao, Wang Jiwu, et al.; ZHONGHUA CHUANRANBING ZAZHI, Aug 90]	8
Separation of Peripheral Blood T and B Lymphocytes From Patients With Epidemic Hemorrhagic Fever and Detection of Specific Viral Antigen in the Cells [Gu Xianshi, You Zhongqiong, et al.; ZHONGHUA CHUANRANBING ZAZHI, Aug 90]	8
Crystallographic Studies on Phospholipase A ₂ From Agkistrodon halys Pallas [Jin Lei, Gui Lulu, et al.; SHENGWUHUAXUE YU SHENGWUWULI XUEBAO, Jul 90]	8
The Chemical Synthesis and Characteristics of a Pig Relaxin Active Peptide [Fu Ping, Du Yucang; SHENGWUHUAXUE YU SHENGWUWULI XUEBAO, Jul 90]	9
The Fusion of the Signal Peptide Region of Leucine-specific Binding Protein Gene to the α -Galactosidase Gene in Escherichia coli [Guo Changwang, Su Tizhi, et al.; SHENGWUHUAXUE YU SHENGWUWULI XUEBAO, Jul 90]	9
Purification and Composition Analysis of the Oligosaccharides of Ricinus communis Agglutinin [Gu Xin, Sun Ce, et al.; SHENGWUHUAXUE YU SHENGWUWULI XUEBAO, Jul 90]	9
Expression of the Human α -Interferon Gene in Insect Cells [Yang Guanzhen, He Jialu, et al.; SHENGWUHUAXUE YU SHENGWUWULI XUEBAO, Jul 90]	10
Expression of Human Insulin-like Growth Factor II in the Mammalian Cells (CHO) [Jia Libin, Ma Anqing; SHENGWUHUAXUE YU SHENGWUWULI XUEBAO, Jul 90]	10
Expression of Hepatitis B Virus Surface Antigen(preS ₂ -S) in Silkworm (Bombyx mori) Cells [Mi Yide, Li Zaiping, et al.; SHENGWUHUAXUE YU SHENGWUWULI XUEBAO, Jul 90]	10
Large-Scale Production of Gibberellin Begins [Li Gang; KEJI RIBAO, 3 May 90]	10
Qigong Application in Fermentation Industry Conducted [Guo Xiao; JINGJI RIBAO, 26 Apr 90]	11
First Gibberella Disease-Resistant Wheat Produced [Fan Jian, Liu Zhijie; KEJI RIBAO, 29 Apr 90]	12

COMPUTERS

Qinghua University Develops Domestic Transputers [Ke Yan, Jiu Chu; JISUANJI SHIJIE, 26 Sep 90]	13
State Bureau Formulates Anti-Computer-Virus Regulations for Census [Wang Xuewu; JINGJI RIBAO, 27 Aug 90]	13
Neural-Net Inference Engine Examined [Yu Shaobo, Yan Junyong; JISUANJI KEXUE, No 4, Aug 90] ..	13
First Domestic Reactor Process Computer System Developed [Shi Jianping; KEJI RIBAO, 28 Sep 90] ..	15
New Hardware for Remote-Sensor Image Processing [Ke Wen; JISUANJI SHIJIE, 26 Sep 90]	15
Vehicle-Mounted Computer Radio Communications Network Developed [Fu Sijing; JISUANJI SHIJIE, 26 Sep 90]	15

FACTORY AUTOMATION, ROBOTICS

Developments in Robotics Reported	16
Pressure-Vessel Crack-Detection Robot [Tie Ping; KEJI RIBAO, 1 Sep 90]	16
Shenyang R&D Center Accredited Liu Xianda; KEJI RIBAO, 2 Sep 90]	16
Zou Jiahua at R&D Center Ribbon-Cutting [Dong Jianzhen; NANFANG RIBAO, 3 Sep 90]	16

First Domestic Underwater Robots on World Market [Yuan Youling, Huang Yong; KEJI RIBAO, 5 Sep 90]	16
Nuclear Power Plant Maintenance Robot [CHINA DAILY, 17 Sep 90]	16
Robots Will Operate Assembly System [Zhong Chen; CHINA DAILY (Shanghai Focus), 17 Sep 90]	17
More on Nuclear Plant Robot [Ji Ren; CHINA DAILY, 1 Oct 90]	19

LASERS, SENSORS, OPTICS

Optical Full Adder Composed of a ZnS Interference Filter [Zha Zizhong, Wang Ruibo, et al; ZHONGGUO JIGUANG, Feb 90]	20
Study of 40 W Copper Vapor Lasers [Tao Yongxiang, Liang Baogen, et al; ZHONGGUO JIGUANG, Feb 90]	22
Nation's First Picosecond Autotuning Parametric Laser Developed [Yi Min; GUANGXUE XUEBAO, No 7, Jul 90]	23
Microwave-Excited kW CO ₂ Laser for Modern Industry [Zhang Zebo, Sun Shuqin; WULI, Apr 90]	24
Situation, Development of Laser Industry in China [Hu Xiaobao, Hua Meirong; YINGYONG JIGUANG, Jun 90]	27

MICROELECTRONICS

Comparative Study of Photoluminescence of In _{0.15} Ga _{0.85} As/GaAs and GaAs/Al _{0.3} Ga _{0.7} As Quantum Wells Under Hydrostatic Pressure [Li Guohua, Zheng Baozhen, et al.; BANDAOTI XUEBAO, No 9, Sep 90]	31
---	----

TELECOMMUNICATIONS R&D

Further Report on Fiber-Optic Cable for Domestic Communications	32
Spectral Symbols, Standard Cable Structures [Xing Jiexiang; DIANXIN JISHU, Aug 90]	32
Recommendations on Optical Parameters [Xing Jian; DIANXIN JISHU, Sep 90]	36
Civil Construction Completed at Chengdu Earth Station [Jiang Zhai; DIANXIN JISHU, No 8, Aug 90]	39
Experimental Study of Photomixing with 1.3-Micron Graded-Index-Rod External-Cavity Semiconductor Laser for Coherent Fiber-Optic System [Zhang Jianping, Hui Rongqing, et al.; TONGXIN XUEBAO, Vol 11 No 2, Mar 90]	39
First DMW System for Guangxi Province [Chen Zhiyong; DIANXIN JISHU, No 8, Aug 90]	43
Reorganization of Satellite Broadcasting Corporation [DIANXIN JISHU, No 8, Aug 90]	43

PLT, BT Ceramic Thin Films Developed via Sol-Gel Technique

91P60018 Wuhan HUAZHONG LIGONG DAXUE XUEBAO [JOURNAL OF HUAZHONG (CENTRAL CHINA) UNIVERSITY OF SCIENCE AND TECHNOLOGY] in Chinese Vol 18 No 4, Aug 90 p 106

[Article by Solid-State Electronics Department, Electronic Materials and Components Teaching & Research Section, Special Ceramics Research Group: "Successful Development of PLT and BT Ceramics via Use of Sol-Gel Technique"]

[Summary] Using the Sol-Gel technique, the Special Ceramics & Thin Films Research Group in our university's Solid-State Electronics Department has prepared the following epitaxially grown perovskite-structure thin films on SrTiO₃ and MgO monocrystalline substrates: (Pb_{1-x}La_x)_{1-x/4}O₃ (abbreviated PLT), and BaTiO₃ (barium titanate, or BT for short).

The exact description of these thin films is as follows: (100)PLT // (100)SrTiO₃, (100)PLT // (100)(MgO) and (110)BT // (110)SrTiO₃, (100)BT // (100)MgO. Also, on substrates of silicon monocrystal and quartz glass, we

have epitaxially grown perovskite-structure polycrystalline thin films. The use of the Sol-Gel technique in epitaxial growth of PLT and BT thin films has not previously been reported in China or abroad.

The PLT and BT ceramic thin films have a withstand-voltage strength E_b greater than or equal to 100kV/cm. Measurements obtained with a ferroelectric hysteresis loop are as follows: for the PLT15 ($x = 0.15$) ceramic thin film, spontaneous polarization strength $P_s = 18 \mu\text{C}/\text{cm}^2$, residual polarization strength $P_r = 7.5 \mu\text{C}/\text{cm}^2$, and coercive field $E_c = 50 \text{ kV}/\text{cm}$; and for the BT ceramic thin film, $P_s = 10.1 \mu\text{C}/\text{cm}^2$, $P_r = 6.04 \mu\text{C}/\text{cm}^2$, and $E_c = 26.1 \text{ kV}/\text{cm}$. For the PLT28 ($x = 0.28$) and BT ceramic thin films in the 500-1000-nanometer wavelength range, penetration rate is over 80 percent.

PLT thin films have applications as dielectric, piezoelectric, thermoelectric, ferroelectric and photoelectric materials, particularly in the fabrication of high-speed, low-drive-voltage optical switches for optical integrated circuits; of high-sensitivity thermoelectric infrared sensors; of acousto-optic Bragg deflectors; and of surface-acoustic-wave devices. BaTiO₃ thin films are useful in fabricating dielectric materials and optoelectronic devices.

Studies on the 120MD Plasmid and Its Derivative Plasmid in *Shigella Sonnei*

40091001A Beijing ZHONGHUA WEISHENGWUXUE HE MIANYIXUE ZAZHI [CHINESE JOURNAL OF MICROBIOLOGY AND IMMUNOLOGY] in Chinese Vol 10 No 4, Aug 90 pp 205-209

[English abstract of article by Liu Wei [0491 0251] and Wang Bingrui [3769 4426 3843] of the Lanzhou Institute of Biological Products, Ministry of Public Health]

[Text] The form I large plasmid of *Shigella sonnei* strain S7 (form I) and the plasmid form II variant strain S7R were studied. Comparisons were done for the wild virulent strain S512, S7, S7R in their virulent phenotypes, the expression of invasive outer membrane polypeptides, plasmid molecular size, plasmids endonucleic restriction and nucleic acid hybridization with gene fragments related to virulence. The results showed that both strain S7 and S7R were avirulent and contained no outer membrane polypeptides a, b, c and d. The MW. of these two large plasmids in strains S7, S7R were 84 and 71 Md respectively, which were smaller than that of the 120Md virulence associated plasmid of the virulent strain. The nucleic acid hybridization in 17 Kb invasive fragment and to 1.0 Kb Congo Red binding gene probes were negative. The form I large plasmid of strain S7 expressed form I antigen, but lost fragments related to virulence. It could be considered as a safe donor for the construction of bivalent or polyvalent vaccines, and strain S7 could be a candidate of *Shigella* vaccine. The existence of the large non-pathogenic associated plasmid in strain S7R may be useful in studying form I gene.

Study on Immunoprotective Effects of the Outer Membrane From *Shigella Flexneri* 2a

40091001B Beijing ZHONGHUA WEISHENGWUXUE HE MIANYIXUE ZAZHI [CHINESE JOURNAL OF MICROBIOLOGY AND IMMUNOLOGY] in Chinese Vol 10 No 4, Aug 90 pp 210-213

[English abstract of article by Xu Xiaoping [1776 2556 1627], Chu Lianrui [0443 6647 3843], and Su Xin [5685 2450] of the Institute of Microbiology and Epidemiology, Academy of Military Medical Sciences, Beijing]

[Text] Outer and inner membranes separated from *S. flexneri* 2a by density gradient centrifugation were used for the preparation of antisera against those membrane components, and their active and passive immunoprotective effects on mice were also studied. Outer membrane (OM) shows higher extent of immunoprotection than inner membrane (IM) and can induce local protection in sereny test by subcutaneous injection. Antiserum from the rabbit immunized with outer membrane of F2a can afford passive protection to mice not only against homologous bacteria, but also flexneri 3a and *S. sonnei* though this antiserum shows no reaction with LPS of *sonnei* in immunoblot assay. Elimination of anti-LPS antibodies from the antiserum does not result in the loss

of protection against flexneri 2a, indicating that anti-protein antibodies in antiserum is responsible for protection. It may be concluded that some outer membrane proteins are efficient protective antigen which can elicit cross protective immunity against *Shigella* spp. It is found by immunoblot technique that F2a, F3a and *S. sonnei* share at least 10 outer membrane proteins reacting with the anti-F2a outer membrane antiserum.

Key words: *Shigella flexneri*, Outer membrane, Immunoprotection

Purification of *Autographa Californica* Nuclear Polyhedrosis Virus DNA and Cloning of the Polyhedrin Gene

40091001M Beijing YICHUAN XUEBAO [ACTA GENETICA SINICA] in Chinese Vol 17 No 4, Aug 90 pp 321-326

[English abstract of article by Li Yiping [2621 0076 1627], Xin Jihou [1823 4764 0624], and Li Zaiping [2621 6528 1627] of the Shanghai Institute of Biochemistry, Academia Sinica, Shanghai]

[Text] *Autographa californica* nuclear polyhedrosis virus (AcNPV) DNA from larvae of lepidopteran infected by AcNPV has been isolated. The EcoRI fragments of AcNPV DNA have been cloned using plasmid pBR325 as a vector. The polyhedrin gene fragment containing recombinant plasmid pAc-18 was isolated through in situ hybridization. For the convenience of further construction the EcoRI insertion fragment was cloned into pUC-8. Thus plasmid pUAc-2 was obtained. The results of restriction mapping of pAc-18 and pUAc-2 and part of the sequence were reported. The polyhedrin promoter was known to be one of the most effective promoter useful in the expression of foreign genes in the insect cells.

Preliminary Application of Monoclonal Antibodies in the Analysis of Epitopes Present on the Outer Membrane of *Shigella Flexneri* 2a

40091001C Beijing ZHONGHUA WEISHENGWUXUE HE MIANYIXUE ZAZHI [CHINESE JOURNAL OF MICROBIOLOGY AND IMMUNOLOGY] in Chinese Vol 10 No 4, Aug 90 pp 214-217

[English abstract of article by Zhang Weifen [1728 5633 5358], Wu Xin [5685 2450], Zhou Jiamin [0719 0163 2404], and Chu Lianrui [0443 6647 3843] of the Institute of Microbiology and Epidemiology, Academy of Military Medical Sciences, Beijing]

[Text] Seven hybridoma cell lines were established by fusing SP2/0 myeloma cells with spleen cells of BALB/c mice which had been immunized by partially purified membrane antigen of *Flexneri* 2a (F2a). One of them recognizes a protein which has nothing to do with immunoprotection, the others recognize the O-side chain of LPS. The passive immunoprotective test on

mice and the analysis of epitope show a close relationship between O-chain and some epitopes with immunoprotection.

Key words: *Shigella flexneri* 2a; Monoclonal antibody; Immunoprotection; O-chain; Antigenic epitope; LPS (Lipopolysaccharide)

Establishment of CHO Cell Assay To Examine the Biological Activity of Edema Factor (EF) of Anthrax Toxin

40091001D Beijing ZHONGHUA WEISHENGWUXUE HE MIANYIXUE ZAZHI [CHINESE JOURNAL OF MICROBIOLOGY AND IMMUNOLOGY] in Chinese Vol 10 No 4, Aug 90 pp 218-220

[English abstract of article by Nan Li [0589 7787] of the Molecular Genetics Center and Hu Juan [5170 1227] of the Institute of Microbiology and Epidemiology, Academy of Military Medical Sciences]

[Text] Nowadays people are still using Guinea Pig Edematous Test (GPET) to estimate the biological activity of EF though it is not sensitive and convenient enough to satisfy all investigators. We are the first of establishing Mouse Edematous Test (MET) which is 27 times more sensitive than GPET and is more convenient. To develop a more sensitive method to estimate micro-quantitative EF, a CHO cell assay was established based on the fact that CHO (Chinese Hamster Ovary) cells could become substantially elongated after they being exposed to EF and PA (protective antigen of Anthrax toxin), and it was 23,475 times more sensitive than GPET and 869 times than MET.

Key words: Edema factor of Anthrax toxin, CHO cells

Preparation and Analysis in Vitro of McAb-Adriamycin Immunoconjugate Against Human Glioma

40091001E Beijing ZHONGHUA WEISHENGWUXUE HE MIANYIXUE ZAZHI [CHINESE JOURNAL OF MICROBIOLOGY AND IMMUNOLOGY] in Chinese Vol 10 No 4, Aug 90 pp 243-247

[English abstract of article by Hu Zhiqing [5170 1807 7230] and Yang Guizhen [2799 6311 6297] of the Department of Immunology, Bethune University of Medical Sciences, Changchun]

[Text] McAb 5A8 which reacted with 55 kd glioma associated antigen on the glioma cell membrane was conjugated with adriamycin by the covalent binding of the drug to the Ab. The ratio of adriamycin to McAb was 59.5:1 Mol. The conjugate retained both drug and antibody activities and had selectively cytotoxic effect to target cells compared with non-target cells. But its cytotoxic effect was far inferior to the effect of free drug. Besides the partial loss of drug activity after periodate

oxidation, insufficient internalization of the Ag-Ab complex was the major cause for the result. Therefore, antibodies that cannot be internalized are not suitable for anti-cancer drug targeting.

Key words: McAb; Glioma; Adriamycin; Immunoconjugate; Internalization

A Single Amino Acid Substitution of $\alpha 1$ Interferon Changes Its Biological Activities

40091001F Beijing ZHONGHUA WEISHENGWUXUE HE MIANYIXUE ZAZHI [CHINESE JOURNAL OF MICROBIOLOGY AND IMMUNOLOGY] in Chinese Vol 10 No 4, Aug 90 pp 248-251

[English abstract of article by Li Yan [2621 3601] and Hou Yunde [0186 0061 1795] of the National Laboratory of Molecular Virology and Genetic Engineering, Institute of Virology, Chinese Academy of Preventive Medicine, Beijing]

[Text] An interferon mutant, IFN- $\alpha 1/86D$ was constructed by substitution of Cys (TGC) at position 86 of IFN- $\alpha 1/86c$ with Asp (GAC) using nucleotide-directed site specific mutagenesis method. Results obtained from the comparative investigation on their antiviral, antiproliferative as well as NK cell promoting activities showed that the mutant 86D possessed same antiviral activities parent 86C against CoxB1, Sindbis, Ad-3, HSV-1, and MV in Vero cell and stronger antiproliferative ($P < 0.01$) as well as NK cell stimulating activities than its parent 86C. The possible mechanism involved in the changes of biological activities of IFN- $\alpha 1$ by a single amino acid substitution was discussed.

The Study of Cytotoxic Factor Induced by Antiviral i-RNA

40091001G Beijing ZHONGHUA WEISHENGWUXUE HE MIANYIXUE ZAZHI [CHINESE JOURNAL OF MICROBIOLOGY AND IMMUNOLOGY] in Chinese Vol 10 No 4, Aug 90 pp 252-255

[English abstract of article by Yang Mingjiu [2799 2494 0036] and Liu Beixing [0491 0554 2502], et al. of the Department of Immunology, China Medical University, Shenyang]

[Text] A cytotoxic factor was elicited in rabbit serum (RSCF) by an iv injection of different antiviral i-RNA (RSV i-RNA or CMV i-RNA) 5-7 days after primed by 4 consecutive daily ip injection of the same i-RNA. Our results showed that HeLa and Hep-2 cell lines injected by RSV as target cells were effectively killed by RSCF, though normal cell lines (HeLa and Hep-2) were not sensitive. We also made a discussion on the therapeutic mechanism of antiviral i-RNA and the components of RSCF activity.

Key words: Antiviral i-RNA; Respiratory syncytial virus i-RNA (RSV i-RNA); Cytomegalovirus i-RNA (CMV i-RNA); Rabbit serum cytotoxic factor (RSCF)

Detection of HFRSV-Ag and Isolation of HFRSV From CSF of the Patients With Brain-Type HFRS

40091001H Beijing ZHONGHUA WEISHENGWUXUE HE MIANYIXUE ZAZHI [CHINESE JOURNAL OF MICROBIOLOGY AND IMMUNOLOGY] in Chinese Vol 10 No 4, Aug 90 pp 256-259

[English abstract of article by Li Ge [2621 7245], Fang Liang [2455 0081], et al. of the Research Laboratory of Virology, Xi'an Medical University]

[Text] HFRSV-Ag was detected with the Ring Precipitation Test (RPT), Coagglutination of Staphylococcus Protein A (Co-SPA) and ELISA. A strain of virus was isolated in Vero-E6 cell from the CSF of the HFRS patient with typical brain-type in the epidemic season of 1986 and could be passed continuously in vitro. The isolated virus was identified by means of different serological methods such as RPT, Co-SPA, immunofluorescent assay (IFA), ELISA, their blocking tests for positive specimens and intra-cerebral (IC) inoculation of HFRSV-sensitive suckling mice with infected cell suspension. The results of this identification prove that the isolated virus is a strain of HFRSV, we named it Strain SC. A morphological study of immune EM and ultra thin sections of the cell and the brains of the suckling mice infected with the Strain XC by using EM gave evidence for taxonomic identification of Strain XC as a member of the family Bunyaviridae.

Key words: HFRSV (hemorrhagic fever renal syndrome virus)

Antigenic Analysis of Chinese Strains of Spotted Fever Group Rickettsiae With Monoclonal Antibodies by Immunoblotting

40091001I Beijing ZHONGHUA WEISHENGWUXUE HE MIANYIXUE ZAZHI [CHINESE JOURNAL OF MICROBIOLOGY AND IMMUNOLOGY] in Chinese Vol 10 No 4, Aug 90 pp 260-262

[English abstract of article by Yu Xiejie [0060 1331 2638], Fan Mingyuan [5400 2494 6678], et al., of the Institute of Epidemiology and Microbiology, Chinese Academy of Preventive Medicine, Beijing]

[Text] Three murine monoclonal antibodies (McAbs) against *R. sibirica* strain 232 were constructed in this study. Two of them, C11-D1 and A9-G4 were species-specific to *R. sibirica*. One of them, C11-C2 was group reactive to all members of spotted fever group (SFG) rickettsiae tested. All of these McAbs reacted with only heat sensitive and proteinase K sensitive epitopes of *R. sibirica*. A9-G4 and C11-C2 recognized an antigenic polypeptide of *R. sibirica* with the molecular weight of

130 KD, C11-D1 reacted with both 130 KD and 118 KD antigenic polypeptides of *R. sibirica*. These McAbs demonstrated that all 7 Chinese strains of SFG rickettsiae isolated from the Northern China shared the identical antigenic polypeptides with *R. sibirica* (strains 232 and 246) by immunoblotting.

Key words: Monoclonal antibody; Spotted fever group rickettsiae; Immunoblotting *R. sibirica* (Rickettsiae sibirica)

Cytogenetic Effects of Attenuated Live Measles Vaccine on Male Mice

40091001J Beijing YICHUAN XUEBAO [ACTA GENETICA SINICA] in Chinese Vol 17 No 4, Aug 90 pp 269-275

[English abstract of article by Shi Qinghua [0670 1987 5478] and Shi Liming [2457 4539 2494] of the Kunming Institute of Zoology, Academia Sinica, Yunnan]

[Text] The cytogenetic effects of attenuated live measles vaccine on somatic and germinal cells of C57BL/6J mice were studied. The frequencies of micronuclei of polychromatic erythrocytes, nucleated cells, chromatid breaks, fragments in bone marrow cells, and micronuclei of spermatids in tests were increased, which have dose- and time-dependent relationship. However, there were no statistical difference between the treated and control mice in chromosomal breaks and fragments of spermatogonia primary and secondary spermatocytes. The results and their possible biological significance were also discussed.

Studies of Chromosome G-Banding in Rice (*Oryza sativa*)

40091001K Beijing YICHUAN XUEBAO [ACTA GENETICA SINICA] in Chinese Vol 17 No 4, Aug 90 pp 301-307

[English abstract of article by Yao Qing [1202 7230], Song Yunchun [1345 6663 3196], and Liu Lihua [0491 4539 5478] of the Department of Biology, Wuhan University; project sponsored by the National Natural Science Foundation of China]

[Text] Advanced ASG method of G-banding was used in this study. Mitotic chromosome G-banding patterns and their corresponding karyotypes of rice cultivars Zhen Shan 97 (*O. sativa* subsp. *indica*) and Xiu Ling (*O. sativa* subsp. *japonica*) have been studied comparatively. Multiple adjacent bands were observed along the total length of each chromosome. Some of these bands were thick and intensively stained, the others were thin and lightly stained. Differences in G-banding patterns were found between nonhomologous chromosomes, there are while two members of each chromosome pair were similar in the numbers, size and staining degree of bands. [sentence as published] Homologues can be matched exactly on the basis of G-banding patterns.

Chromosome banding patterns including band numbers in three different mitotic stages of the same experimental material have been compared. Band number decreased gradually from prophase to metaphase. Thin and lightly stained bands in prophase combined into thick and intensively stained bands in metaphase. Chromosomes in late prophase showed the best G-banding patterns. We also compared banding patterns of indica with that of japonica in late prophase. The numbers, size and staining degree of bands between the two subspecies were basically the same.

We have discussed the relations between G-bands and regional differentiation of chromosome, and those between G-banding patterns and the diversity of the two subspecies, as well as the key points of the method used in this study.

The Construction of Shuttle Plasmid Vector of *Streptomyces* and *E. coli*

40091001N Beijing YICHUAN XUEBAO [ACTA GENETICA SINICA] in Chinese Vol 17 No 4, Aug 90 pp 327-334

[English abstract of article by Tan Huarong [6223 5478 2837], He Song [0149 2646], Zhuang Zenghui [8369 1073 6540], and Xue Yugu [5641 4416 6253] of the Institute of Microbiology, Academia Sinica, Beijing]

[Text] A shuttle plasmid vector, pSE-3 was constructed using the *Streptomyces* plasmid pIJ486 and *E. coli* plasmid pGEM-3 digested with Bgl11 and BamHI respectively. The shuttle plasmid pSE-3 could replicate and express is neomycin resistance in both *Streptomyces* and *E. coli* well.

The pSE-3 has opposed promoters containing bacteriophage ST6 and T7, the restriction enzyme digestion showed that the pSE-3 has a single site with HindIII and EcoRI respectively, it is very useful for the cloning and expression of the valuable gene inserts. The pSE-3 is stable in both of *Streptomyces* and *E. coli* after re-transformed pSE-3 is re-transformed from *Streptomyces* into *E. coli* and some 50 generations are propagated.

Construction of Promoter Probe Vector pFDC4 and Gene Expression Vector pFDC11 With High Transformation Efficiency in *Bacillus stearothermophilus*

40091001L Beijing YICHUAN XUEBAO [ACTA GENETICA SINICA] in Chinese Vol 17 No 4, Aug 90 pp 313-320

[English abstract of article by He Xiaosong [0149 4562 2646], Shen Renquan [3088 0088 2938], and Sheng Sujia [4141 4371 0857] of the Institute of Genetics, Fudan University, Shanghai]

[Text] A 0.5 kb fragment from Sau3A-digested total DNA of *Bacillus stearothermophilus* CU21 was cloned with the vector pPGV5, a derivative of pPL703. The

insertion of this fragment can activate the expression of the promoterless cat-86 gene on the cloning vector in both *B. stearothermophilus* and *Bacillus subtilis* hosts. When the 0.54 kb fragment is present in pPGV5 in either orientation, the transformation efficiency of the plasmid is increased from 10^3 to 10^4 fold in CU21 protoplasts. Southern hybridization showed this 0.54 kb fragment was homologous with a 1.6 kb fragment, which was shown by Imanaka et al. (1984, J. Gen. Microbiol. 130, 1399-1408) to originate in a cryptic plasmid resident in CU21 and to enhance the transformation efficiency of another plasmid. With this 0.54 kb fragment a new promoter probe vector pFDC4 and a gene expression vector pFDC11 were constructed. Both can transform the CU21 recipient with high efficiency.

Cloning and Expression of Parasporal Crystal Protein Gene of *Bacillus Thuringiensis* Var. *Galleriae* 81-6 Strain

40091001O Beijing WEISHENGWU XUEBAO [ACTA MICROBIOLOGICA SINICA] in Chinese Vol 30 No 4, Aug 90 pp 249-253

[English abstract of article by Wang Zhiyong [3769 2535 0516] and Wu Baihua [0702 2672 2901] of the Department of Virology and Molecular Biology, Wuhan University, Wuhan]

[Text] Two small plasmids and one large plasmid from *Bacillus thuringiensis* var. *galleriae* strain 81-6 were detected by a simple, rapid method. The donor plasmid which was extracted by alkaline method and the vector plasmid pCAMPUC were digested with PstI and ligated with T4 ligase. The recombination plasmid was transferred into protoplasts of *Bacillus thuringiensis* var. *kurstaki* HD-1 cryB strain. Transformants were screened by ELISA method for the producing of crystal protein in cryB strain. A positive strain was obtained. The insertion fragment of crystal protein gene was about 7.27 kb. The bioassay of positive transformant showed toxic effect to lepidopteran.

Separation and Purification of the Toxic Protein of *Bacillus Sphaericus* Ts-1

40091001P Beijing WEISHENGWU XUEBAO [ACTA MICROBIOLOGICA SINICA] in Chinese Vol 30 No 4, Aug 90 pp 254-258

[English abstract of article by Yu Ziran [0060 5261 3544], Shang Kejin [1424 0344 6651], et al. of the Department of Biology, Nankai University, Tianjin]

[Text] *Bacillus sphaericus* strain Ts-1 is highly insecticidal to larvae of the mosquito. Its insecticidal component is toxic proteins. The toxin was extracted from spore-crystal complexes by disruption in a Sonicator Cell Disruptor Model W-220F followed by treatment with 0.05 mol/L NaOH. Fraction recovered from chromatography of the spore-crystal complexes on column of Sephadex G-200 were assayed against mosquito larvae

and the toxic fractions from gel chromatography were subjected to SDS-PAGE. The toxic proteins in *S. sphaericus* Ts-1 spore-crystal complex migrated in position corresponding to 42 kD and 43 kD.

Bioassay of the two purified proteins prepared by PAGE indicated that they were all toxic to mosquito larvae.

Toxic protein was further purified by DEAE-cellulose chromatography. The toxic protein with a molecular weight of 42 kD was obtained.

A New Serotype of *Shigella* *Boydii*

40091001Q Beijing WEISHENGWU XUEBAO [ACTA MICROBIOLOGICA SINICA] in Chinese Vol 30 No 4, Aug 90 pp 284-295

[English abstract of article by Yang Zhengshi [2799 2973 2524] of the National Institute for the Control of Pharmaceutical and Biological Products, Beijing, Hu Chaowen [5170 6389 2429] of the Huaihua Regional Hygiene and Anti-Epidemic Station, Huaihua, Chen Jian [7115 1017], Chen Guiqiu [7115 6311 4428], and Liu Zonggen [0491 1350 1869] of the Hunan Province Hygiene and Anti-Epidemic Station, Changsha]

[Text] Two strains which belong to the same serotype of *Shigella* were isolated from the bloody-pus stool of two patients (in 1986) and is reported in this paper. The results were identical both showing agglutination in low titer with serotype 8 of *S. dysenteriae* and serotype 4 of *S. boydii* when the two strains were checked well with all kinds of diagnostic antisera and vice versa, the antisera produced by the two strains were also checked well with sera prepared with the representative strains of all *Shigella* spp. No cross agglutination with O₆, O₇ and O₁₅₀ of *E. coli* were found. Consequently, it appears to be a new serotype of *Shigella*. These two strains possess the ability of causing keratitis in guinea-pigs as well as invading epithelial cells, the DNA of both strains in agarose-electrophoresis showed a large plasmid, indicating that they are virulent strains possessing invasive ability.

It was concluded that these two strains belonged to *Shigella boydii* as they fermented mannitol and non-related antigenically with *Shigella flexneri*. Since serotype 1-18 of *S. boydii* have been reported recently, we propose that this new serotype should be serotype 19 of *Shigella boydii*.

Specific Monoclonal Antibodies to F41 Adhesin of Enterotoxigenic *Escherichia Coli* and Their Potential Uses as Diagnostic and Therapeutic Reagents

40091001R Beijing WEISHENGWU XUEBAO [ACTA MICROBIOLOGICA SINICA] in Chinese Vol 30 No 4, Aug 90 pp 305-311

[English abstract of article by Yang Liang [2799 0081] and Liu Xiufan [0491 4423 2753] of the Department of Veterinary Science, Jiangsu Agricultural College, Yangzhou]

[Text] A set of hybridoma cell lines, namely, L10, B10, C32, B1, E7, E40 and B49, secreting monoclonal antibodies (MABs) specific to F41 adhesin antigens of ETEC was obtained by somatic hybridization. These MABs manifested strongly specific binding reactivities in DA, ELISA and IFA to all tested F41⁺ ETEC strains. All these MABs recognized the same or closely related epitopes on the adhesin, as indicated in antigen-competition ELISA with HRP-labeled MABs. The distribution patterns of these epitopes which appeared repeatedly on each pilus were visualized by MAB-immunogold technique and immunoelectron microscopy. The adhesion of ETEC bearing F41 adhesin to the epithelial cells of small intestine from new borne calves and piglets was inhibited in vitro by F41-specific MABs.

A dot-immunobinding assay based on F41-specific MABs was developed for determining F41 antigens in fecal samples with HRP-labeled MABs. The assay was highly sensitive and specific, and could be used in rapid detection and screening of F41 adhesin antigens in field samples.

Predicting Carcinogens With Genetic Toxicology Tests: Role and Strategy

40091001T Beijing BEIJING YIKE DAXUE XUEBAO [JOURNAL OF BEIJING MEDICAL UNIVERSITY] in Chinese Vol 22 No 4, Aug 90 pp 246-248

[English abstract of article by Zhou Zongcan [0719 1350 3503], Fu Juanling [0265 1227 7881], et al. of the Department of Health Toxicology]

[Text] The analysis of our database of carcinogenicity and genotoxicity of chemicals demonstrates the uncertainty of genetic toxicology tests to predict carcinogens. Salmonella reverse mutation test is the basic screening test and most routine tests statistically depend. An adequate test battery should consist of the tests to detect different genetic endpoints including at least one or more mammalian test in vivo. The strategy combining genetic toxicology tests and carcinogenicity test for carcinogen identification is recommended.

Embryonic Toxicity of Di-Ku-Shuang (Bis-A-TDA) on *Drosophila Melanogaster* and the Detoxication of Niacinamide

40091001U Chengdu SICHUAN DAXUE XUEBAO [JOURNAL OF SICHUAN UNIVERSITY—NATURAL SCIENCE EDITION] in Chinese Vol 27 No 3, Aug 90 pp 343-347

[English abstract of article by Zeng Fanya [2582 0416 0068], Wang Fangyuan [3769 2455 0337], Xiao Yongli [5135 0516 4539], and Zhang Jian [1728 0256] of the Department of Biotechnology]

[Text] The known teratogen, Bis-A-TDA (N, N'-Methylene-bis (2-amino-1, 3, 4-thiadiazole)), was tested for influence on embryonic development of *D. melanogaster*. Treatment consisted of rearing the fly larvae in

media containing Bis-A-TDA concentrations of 0, 10, 100, 150, 200, 250, 350, 500, 750 and 1000 ppm. Emerging flies were counted and inspected for gross malformation. Toxicity inhibition test was conducted with medium containing inhibitor-niacinamide and Bis-A-TDA both on concentration of 200 ppm. The results show: 1) There is a line relationship between the embryonic toxicity of Bis-A-TDA and its dosage. When the dosage rises from 150 to 350 ppm, the number of emerging flies decreases and malformation flies increase dramatically. Among larvae, pupa and adult fly, pupa is most sensitive to Bis-A-TDA. 2) Niacinamide can partly inhibit the embryonic toxicity of Bis-A-TDA in *D. melanogaster*. 3) Low concentration of Bis-A-TDA (10 to 100 ppm) can enhance embryonic development of *D. melanogaster*.

Key words: Embryonic, Embryonic Toxicity, *Drosophila melanogaster*, Niacinamide, Bis-A-TDA, Detoxication

Synthesis of 4-(N-Substituted) Aminomethyl Phenylalanines

40091001V Changchun YINGYONG HUAXUE
[CHINESE JOURNAL OF APPLIED CHEMISTRY]
in Chinese Vol 7 No 4, Aug 90 pp 72-74

[English abstract of article by Liu Keliang [0491 0344 5328] and He Binglin [0149 3521 2651] of the Institute of Polymer Chemistry, Nankai University, Tianjin 300071, and Xiao Shaobo [5618 4801 0590] of Tianjin Municipal Research Institute for Family Planning, Tianjin Medical College]

[Text] For the development of high activity, low side effect peptide drugs, the new 4-(N-substituted) aminomethyl phenylalanines are presented. Dialkylamine reacted with N-acetyl-4-chloromethyl phenylalanine ethyl ester to give phenylalanine derivatives with basic side groups. After hydrolysis in hydrochloric acid and protection with Boc group the amino acids have been successfully used in solid phase peptide synthesis. This series amino acids combine basicity, aromaticity and hydrophilicity in the same molecule and have different N-dialkyl groups in length, they can be used in systematic research on structure-bioactivity relationships of peptides.

Key words: 4-(N-dialkyl) aminomethyl phenylalanine, nonprotein amino acid, peptide analog

Glucose Biosensor Based on Cobalt Porphyrin Modified Glassy Carbon Electrode

40091001W Changchun YINGYONG HUAXUE
[CHINESE JOURNAL OF APPLIED CHEMISTRY]
in Chinese Vol 7 No 4, Aug 90 pp 93-95

[English abstract of article by Zhang Yonghua [1728 0737 5478] and Feng Lianyu [7458 6647 3768] of the Laboratory of Electroanalytical Chemistry, Changchun Institute of Applied Chemistry, Academia Sinica, Changchun]

[Text] A glucose electrode was constructed using a cobalt tetraphenyl porphyrin modified electrode with response time of less than 4 s. A linearship was obtained between the current decrease and the glucose concentration in the range of 0.05-0.8 mmol/L. The activity of the glucose oxidase kept unchanged for 3 months in icebox condition. The selectivity was satisfactory.

Key words: biosensor, modified electrode, glucose

Expression of Human Interleukin 4 Fusion Protein in E. Coli With High Efficiency

40091001S Beijing BEIJING YIKE DAXUE XUEBAO
[JOURNAL OF BEIJING MEDICAL UNIVERSITY]
in Chinese Vol 22 No 4, Aug 90 pp 241-245

[English abstract of article by Ma Dalong [7456 1129 7893], Guo Shujun [6753 3219 0689], et al. of the Department of Immunology]

[Text] The EcoRV-BamHI fragment of human interleukin 4(huIL-4) cDNA cleaved from pCD-huIL-4 plasmid was inserted into EcoRV/BamHI treated pEX2ΔH plasmid via ligation, which resulted in the construction of pR-hIL-4 plasmid. The validity of the construction was conformed by the restriction map of the pR-hIL-4 plasmid, and by the expression of novel fusion protein of 60 Kd in host *E. coli* transformed with pR-hIL-4. The constructed pR-hIL-4 plasmid contains all cDNA sequence but nine bp at the 5' terminal coding for mature human IL-4 molecule. The β-galactosidase-human IL-4 fusion protein did not have human IL-4 biological activity, indicating the critical role of -NH₂ terminal three amino acids of IL-4 in the exhibition of IL-4 activity, which are lacked in the IL-4 fusion protein. The antiserum has been prepared by immunization of mice and rabbits with fusion proteins. The antisera immunoprecipitated with fusion proteins and specifically bound to purified human IL-4 with high titer in the dot-blotting assay. It indicates that the fusion protein contains human IL-4 moiety. The antiserum was unable to block human IL-4 biological activity. Because of good immunogenicity and high yield of fusion protein, which accounting for 30 percent of total bacterial proteins, as well as its specific binding with human rIL-4, the potential application of this fusion protein is to develop immunoassay for the measurement of human IL-4.

Studies on R Plasmid From Multiresistant Salmonella Typhi

40091002A Shanghai ZHONGHUA CHUANRAMBING ZAZHI [CHINESE JOURNAL OF INFECTIOUS DISEASES] in Chinese Vol 8 No 3, Aug 90 pp 139-143

[English abstract of article by Huang Rui [7806 3843] and Mu Rongpu [4476 2837 2528], Biotechnical Research Center, Suzhou Medical College]

[Text] From 1987 to 1988, 259 strains of *S. typhi* in Suzhou area were collected. Two hundred and nine

strains (80.7 percent) of them were multiresistant to either 9 or 11 antibiotics with an average of 10.6. Agarose gel electrophoresis analysis of plasmid DNA showed that the plasmid pattern was uniform. All resistant strains had a large plasmid band with a molecular weight of about 98.6 Mdal. The conjugation test showed that the plasmids of all resistant strains were transmissible. By the technique of transformation and elimination of plasmid in part of the resistant strains, it was proved that the multiresistance of *S. typhi* isolated in Suzhou area was mediated by resistant plasmid. The confirmation of this R plasmid is of much help to the identification of pathogenic bacteria, drug resistant surveillance and epidemiological survey.

Influence of Ribaverin Upon Elimination of Urinary Electrolytes in Patients With Epidemic Hemorrhagic Fever

40091002B Shanghai ZHONGHUA CHUANRANBING ZAZHI [CHINESE JOURNAL OF INFECTIOUS DISEASES] in Chinese Vol 8 No 3, Aug 90 pp 147-149 & 138

[English abstract of article by Guan Mieying [4619 5019 5391], Zhou Xinchun [0719 2450 2504], et al., Department of Infectious Diseases, The First Affiliated Hospital, Hubei Medical College]

[Text] Elimination of 24-hr urinary potassium on the 2nd day after ribaverin therapy in the early stage of patients with epidemic hemorrhagic fever was significantly higher than in controls ($p < .001$), especially those were admitted before 4 days of the disease. However urinary potassium in the early stage of treated patients was higher than normal value. Elimination of 24-hr urinary sodium on the 2nd day after treatment was significantly higher than controls ($p_{.01} \approx p_{.001}$), especially those of the early stage. However urinary sodium in patients of both groups was lower than normal value. Urinary sodium in the early stage of treated patients reached normal value 6 days after treatment. Elimination of urinary chloride on the 2nd day after treatment was significantly higher than controls. The results indicated that elimination of urinary electrolytes was significantly increased especially in the early stage.

Study on the Sites of Epidemic Hemorrhagic Fever Virus Multiplication in a Fetus

40091002C Shanghai ZHONGHUA CHUANRANBING ZAZHI [CHINESE JOURNAL OF INFECTIOUS DISEASES] in Chinese Vol 8 No 3, Aug 90 pp 150-153

[English abstract of article by Xu Xiao [1776 2556], Wang Jiwu [3769 1323 0582] et al., Department of Infectious Disease, Zhejiang Medical University]

[Text] Various organs of a premature dead-fetus from an 8-month pregnant woman infected with epidemic hemorrhagic fever (EHF) virus were systematically examined for the sites of EHF virus multiplication with the

methods of viral isolation, innumofluorescence and ABC immunohistochemistry. Out of 13 organs studied, EHF virus antigens were found and the virus isolated from spleen, lymph nodes, thymus and liver of the fetus. The virus titers in these 4 organs were $10^{3.7} \text{ID}_{50}/\text{ml}$, $10^{4.0} \text{ID}_{50}/\text{ml}$, $10^{1.2} \text{ID}_{50}/\text{ml}$ and $10^{2.6} \text{ID}_{50}$ respectively. With the method of ABC immunohistochemistry, the virus antigens in these organs could only be found in cytoplasm of the macrophages and lymphocytes but not in vascular endothelial cells. Pathological changes characterized as early stage of EHF including congestion, exudation, hemorrhages and degeneration of various degrees were found in the organs examined.

Separation of Peripheral Blood T and B Lymphocytes From Patients With Epidemic Hemorrhagic Fever and Detection of Specific Viral Antigen in the Cells

40091002D Shanghai ZHONGHUA CHUANRANBING ZAZHI [CHINESE JOURNAL OF INFECTIOUS DISEASES] in Chinese Vol 8 No 3, Aug 90 pp 154-156

[English abstract of article by Gu Xianshi [7357 0341 0099], You Zhongqiong [3266 0022 8825], et al., Health and Antiepidemic Station, Guang'an, Sichuan]

[Text] Total blood lymphocytes were prepared from patients suffering from hemorrhagic fever with renal syndrome (HFRS) by a density gradient on Ficoll-Hypaque, and then T and B cells were purified by passing the lymphocytes over a modified nylon wool column. The purity of the total lymphocytes, T and B cells were 97.8 plus over minus 2.3%, 91.6 plus over minus 4.5% and 74.2 plus over minus 12.1% respectively. As cell fixation and drying were improved, the number of cells remained on slides was shortened, thus the quality of the slides being much improved.

Specific viral antigen was detected by immunofluorescence assay using monoclonal antibody against Hanta-virus (HTNV). It was shown that the total lymphocytes, T and B cells from the patients infected with HTNV during the early stage of the disease and no specific fluorescence could be seen in the cells in the late diuretic phase to convalescent phase. The results suggest that virus-infected blood lymphocytes in HFRS may contribute partly to the impairment of immune response and to the in vivo spread of HTNV to its target sites in the early stage of the disease.

Crystallographic Studies on Phospholipase A₂ From *Agkistrodon halys Pallas*

40091002E Shanghai SHENGWUHUAXUE YU SHENGWUWULI XUEBAO [ACTA BIOCHIMICA et BIOPHYSICA SINICA] in Chinese Vol 22 No 4, Jul 90 pp 313-320

[English abstract of article by Jin Lei [6855 4320], Gui Lulu [2710 3873 3873], et al., (Institute of Biophysics,

Academia Sinica, Beijing) and Chen Yuancong [7115 6678 5115], (Shanghai Institute of Biochemistry, Academia Sinica)]

[Text]

Abstract

Two types of crystals have been grown from the venom of *Agkistrodon halys* Pallas, using the vapor diffusion hanging drop method for a presynaptic neutral phospholipase A₂(PLA₂). One crystal type belongs to space group P2₁2₁2₁ and the other, to C2. The latter was considered to possess a bound Ca²⁺ ion which is essential to the functioning of such enzymes. Both types of crystals were shown to be suitable for X-ray crystallographic analysis, with similar cell constants and containing 8 molecules in one asymmetric unit.

Intensity data for the reflection in an asymmetric unit of reciprocal space at 4.1 Å over A resolution for the P2₁2₁2₁ crystal and 5 Å over A resolution for the C2 crystal were collected on a Philips PW1100 four circle diffractometer. Calculation of the Patterson function for the P2₁2₁2₁ crystal and self rotation function for the C2 crystal (using the data obtained) compared favorably with deductions arrived at by careful inspection of the precession photographs that both crystals have the same pseudosymmetry of space group C222₁. The enzyme probably would exist as an aggregate in the crystals, probably a dimer from molecular weight measurements. These data imply that the packing of the molecules in the crystal has undergone changes when the Ca²⁺ is bound.

The Chemical Synthesis and Characteristics of a Pig Relaxin Active Peptide

40091002F Shanghai SHENGWUHUAXUE YU SHENGWUWULI XUEBAO [ACTA BIOCHIMICA et BIOPHYSICA SINICA] in Chinese Vol 22 No 4, Jul 90 pp 321-330

[English abstract of article by Fu Ping [0102 5493] and Du Yucang [2629 7183 5547] (Shanghai Institute of Biochemistry, Academia Sinica) and G. Tregear (Howard Florey Institute of Experimental Physiology and Medicine, University of Melbourne, Australia)]

[Text]

Abstract

An analog of pig relaxin with Met of the A-chain at position 2 replaced by Tyr, and with 5 amino acid residues of the B-chain at the C-terminal removed, has been synthesized. The peptide chains of [Tyr²]_{A(1-22)} and B₍₁₋₂₆₎ were separately assembled by stepwise coupling of Fmoc amino acids on 1 percent crosslinked p-alkoxybenzyl alcohol polystyrene resins. After TFA cleavage, deprotection and S-sulfonation of peptide-resins, the S-sulfonates of A and B were purified on a DEAE-Sephacel column and combined in the presence of DTT. The combined analog was purified by HPLC

and evaluated by CD spectra and mouse uterus contraction assay. The results showed that the synthetic analog was identical with natural pig relaxin in bio-activity and solution conformation. Some properties of relaxin chains were also discussed.

The Fusion of the Signal Peptide Region of Leucine-specific Binding Protein Gene to the α-Galactosidase Gene in Escherichia coli

40091002G Shanghai SHENGWUHUAXUE YU SHENGWUWULI XUEBAO [ACTA BIOCHIMICA et BIOPHYSICA SINICA] in Chinese Vol 22 No 4, Jul 90 pp 331-339

[English abstract of article by Guo Changwang [6753 7022 2489], Su Tizhi [5685 1879 0037]; Beijing Institute of Nutritional Resources; M. Adams, D.L. Oxender; Department of Biological Chemistry, University of Michigan; project supported by the National Natural Science Foundation of China and Fund from NIH, USA]

[Text]

Abstract

E. coli strains containing two kinds of in-frame *livK-rafA* fusions have been isolated and characterized. Each of these fusions codes for a hybrid protein with LS-BP sequences at the NH₂-terminus and a large functional COOH-terminal fragment of α-galactosidase. A minicell-producing strain transformed with plasmid pKRaf27-2 produced the hybrid proteins in precursor and mature forms. In the presence of a proton ionophore carbonyl-cyanide m-chlorophenylhydrazone the precursor forms accumulated. The results from this study indicate that the signal peptide and about 14 amino acid residues of LS-BP contain information necessary for their processing.

Purification and Composition Analysis of the Oligosaccharides of Ricinus communis Agglutinin

40091002H Shanghai SHENGWUHUAXUE YU SHENGWUWULI XUEBAO [ACTA BIOCHEMICA et BIOPHYSICA SINICA] in Chinese Vol 22 No 4, Jul 90 pp 349-254

[English abstract of article by Gu Xin [7357 2450], Sun Ce [1327 0374] and Shen Zhaowen [3088 2507 2429] (Shanghai Institute of Biochemistry, Academia Sinica)]

[Text]

Abstract

The structural analysis of oligosaccharides in glycoproteins is the basis for studies on the structure and function of glycoproteins. Hydrazinolysis has been used for the separation of oligosaccharides from *Ricinus communis* agglutinin (RCA₁). Using gel filtration to remove the peptide portion, the oligosaccharides were reduced by NaBH₄, and the oligosaccharides with N-acetylaminoglucositol at the reducing end were obtained.

They were passed through a Bio-Gel P-4 column and three main oligosaccharides were separated. The three portions were then methanolysed, acetylsed and finally transformed into derivatives of trimethylsilane. Gas chromatography of these derivatives showed that oligosaccharide I was $\text{Man}_7\text{GlcNAc}_2$, oligosaccharide II was Man_6 and oligosaccharide III was $\text{Man}_3\text{Fuc}_1\text{GlcNAc}_2$.

Expression of the Human α -Interferon Gene in Insect Cells

40091002I Shanghai SHENGWUHUAXUE YU SHENGWUWULI XUEBAO [ACTA BIOCHIMICA et BIOPHYSICA SINICA] in Chinese Vol 22, No 4, Jul 90 pp 355-361

[English abstract of article by Yang Guanzhen [2799 0385 3791], He Jialu [0149 1367 4389], et al. (Shanghai Institute of Biochemistry, Academia Sinica), Seventh 'Five-Year' Plan's Key Project]

[Text]

Abstract

The insect baculovirus from *Autographa californica* nuclear polyhedrosis virus (AcNPV) was used as expression vector. Human α -interferon gene was expressed in insect cells *S. frugiperda*. We constructed a transfer plasmid pAPIFN α which involved the entire human α -interferon gene under the control of AcNPV polyhedrin gene promoter. The insect cells *S. frugiperda* were cotransfected with the transfer plasmid DNA and AcNPV genomic DNA. By using the plaque assay several times, a recombinant virus AcIFN was obtained. The recombinant virus formed occlusion negative plaques in *S. f.* cells. Southern blotting hybridization revealed that the recombinant AcIFN NPV DNA contained the interferon gene sequence. The *S. f.* cells infected with recombinant virus AcIFN produced 2.6×10^5 U/ml of human α -interferon activity.

Expression of Human Insulin-like Growth Factor II in the Mammalian Cells (CHO)

40091002J Shanghai SHENGWUHUAXUE YU SHENGWUWULI XUEBAO [ACTA BIOCHIMICA et BIOPHYSICA SINICA] in Chinese Vol 22 No 4, Jul 90 pp 363-370

[English abstract of article by Jia Libin [6328 4539 2430], Ma Anqing [7456 1344 0615], et al.; (National Research Center for Oncogenes and Related Genes, Shanghai Cancer Institute)]

[Text]

Abstract

Human insulin-like growth factor II (IGF-II) has been described as a growth factor for certain types of epithelial cells and fibroblasts. In our laboratory, it was found that IGF-II was over-expressed in human liver cancer as well

as in non-malignant liver tissues surrounding the cancer. In this report, a recombinant plasmid pSV2-IGF-II was constructed by inserting human IGF-II cDNA into the eukaryotic expression vector pSV2. After cotransfection with pSV2-DHFR into DHFR- CHO cells the IGF-II was expressed in CHO cells, demonstrated by an antibody against a 67 amino acid IGF-II peptide synthesized in this laboratory. It was shown that IGF-II was secreted into the culture medium, at a concentration of about 5 mg/L. It was demonstrated that the secreted IGF-II exerted stimulating effects on the growth of human lung diploid fibroblasts and human HepG2 hepatoma cells.

Expression of Hepatitis B Virus Surface Antigen (preS₂-S) in Silkworm (*Bombyx mori*) Cells

40091002K Shanghai SHENGWUHUAXUE YU SHENGWUWULI XUEBAO [ACTA BIOCHIMICA et BIOPHYSICA SINICA] in Chinese Vol 22 No 4, Jul 90 pp 385-390

[English abstract of article by Mi Yide [1348 1837 1795], Li Zaiping [2621 6528 1627], Wu Xiangfu [0702 4382 3940]; Shanghai Institute of Biochemistry, Academia Sinica; Chu Ruiyin [0328 3843 6892], Lu Hongsheng [0712 7703 5116]; Sericultural Research Institute of the Chinese Academy of Agricultural Sciences, Zhenjiang]

[Text]

Abstract

The preS₂-gene sequence from HBVadr have been inserted into a *Bombyx mori* nuclear polyhedrosis virus (BmNPV) vector pBK283 to construct a recombinant plasmid pBKS. *Bombyx mori* cells were co-transfected with pBKS and authentic BmNPV DNA. Through homogeneous sequences recombination in the cell, a recombinant virus BmNPVS harboring HBV preS₂-S sequence had been selected. RIA and ELISA tests revealed the infection of *Bombyx mori* cells by the recombinant virus, BmNPVS produced preS₂ protein and HBsAg in the medium as well as in the cell. The possibility of using the system to develop a new efficient HBV vaccine was discussed.

Large-Scale Production of Gibberellin Begins

90FE0192A Beijing KEJI RIBAO [SCIENCE AND TECHNOLOGY DAILY] in Chinese 3 May 90 p 2

[Article by Li Gang [2621 6921], KEJI RIBAO reporter: "Zhong Lian [0022 5114] Fermentation Plant Begins Large-Scale Production of Gibberellin"]

[Text] Zhong Lian Fermentation Plant, a manufacturing firm participating in the State Science and Technology Commission's development program for key sciences and technologies, has acquired the capability to produce 10 tons of gibberellin annually. The large-scale production was set in motion in the beginning this year.

Gibberellin is a high-potency plant-growth stimulator, commonly known as "agent 920". It not only enhances the elongation of hybridized varieties of rice, but also stimulates the growth of fruits of pineapple plants, raises the mature rate of cotton bolls and help to preserve the blossoms and fruits of citrus fruits.

Domestic production of gibberellin started many years ago; unfortunately, because of our obsolete manufacturing technology, the quality of gibberellin produced is often poor. Consequently, the vast farming users have been burdened by the relatively high price for the harvest that gibberellin brings.

Located a Lingbao County in Henan, Zhong Lian Fermentation Factory is equipped with a complete set of stainless steel microbic fermentation tanks and feeding equipment whose design is at the domestic state-of-the-art. The plant is thus able to break away from the shackles imposed by the traditional gibberellin production method. Zhong Lian Fermentation Plant acknowledges the attention bestowed by the State S&T Commission and comrades from the leadership of the Henan Provincial Government, as well as the support extended by other authorities in charge at every level through its various phases of development from planning, equipment procurement and installation, trial runs until formal entry into production.

Qigong Application in Fermentation Industry Conducted

90FE0192C Beijing JINGJI RIBAO [ECONOMIC DAILY] in Chinese 26 Apr 90 p 2

[Article by Guo Xiao [6753 2556], reporter of JINGJI RIBAO: "Scientific Research in Qigong Marching Towards Industrial Application - 'Procedures of Qigong Treatment for Industrial Bacterial Strains' Approved by Expert Panel"]

[Text] The results of a unique scientific research, titled "Procedures of Qigong Treatment for Industrial Bacterial Strains," was reviewed and approved by an expert panel on April 21 in Beijing. The idea of this research was originated from the Qigong Research Department of the Scientific Technologies Development Corporation, a subsidiary of Qinghua University. After they had conducted a preliminary investigation which demonstrated the feasibility of this approach, the qigong researchers successfully completed this project in collaboration with the Microbiology Institute of the Chinese Academy of Sciences and the Huabei [North China] Pharmaceutical Plant. The renowned qigong practitioner, Dr. Yan Xin [0917 2450] also took an active part in this research.

Modern fermentation industry relies heavily on the microbial strains it employs; the selection and cultivation of high-quality and high-producing strains is considered as the core task in the fermentation industry. Conventionally, the most important technique for strain improvement is to induce microbe mutation through physical and chemical means, which is a labor-intensive

and time-consuming process. A saturation phenomenon is often observed in strains that have gone through repeated mutagenic treatments that makes further upgrading of microbial productivity very difficult. In addition the physical and chemical agents that induce mutations are sometimes harmful to humans and the environment as well. In this study, some members of the investigation team exerted energy radiated from the body in qigong dirigation on microbes and other researchers examined the qigong effects on the heredity traits of these strains; therefore introducing the novel idea of strain improvement through qigong treatment into the realm of organism processing. This milestone research took several years to complete.

In the evaluation session, principal investigators introduced the background and scope of this study; researchers from the hydrocarbon metabolism research team of the Microbiology Institute and from the Huabei Pharmaceutical Plant then gave a detailed presentation, supported by experimental data and figures, of the results of the separation, selection, analysis and identification on the samples of tropical *Candida* and *Streptomyces griseus*, terramycin-producing bacterial strains, demethylated aureomycin-producing bacterial strains and penicillin-producing *coeci* strains, which had been treated with qigong by Yan Xin.

Experts and professors from the panel carefully evaluated and checked the results, then deliberately endorsed the findings with their signatures in the official review report, which concluded unequivocally that a good deal of scientific evidence had shown that "Procedures for Treatment of Industrial Bacterial Strains by Qigong" are effective and useful in selection and cultivation of industrial microbial strains. The qigong treatment exhibited a higher success rate in inducing desired mutations and promoted growth in strains examined. It was also observed that this approach is uniquely effective for strains which have been showing swings of saturation to conventional improvement techniques, greatly simplifies the selection and cultivation procedures and shortens the microbial replication periods. Furthermore, it has the added advantage of producing genetically stable strains without employing any hazardous materials. It is the panel's considered opinion that the qigong procedure is a novel biological treatment technique, the first of its kind in the world.

The review panel included Professor Fang Xinfang [2455 1800 5364], Chairman of the State Cultural Strains Preservation Committee and a member of the Academic Council of the Chinese Academy of Sciences; Professor Bei Shizhang [6296 2514 3864], Honorary Director of the Biology Institute of the Chinese Academy of Sciences and also an Academic Council member; Professor Hu Haichang [5170 3189 2490], Vice-Chairman of Scientific Committee, Chinese Qigong Scientific Research Association and an Academic Council member; Professor Xie Hunchang [6200 3565 4545], Chairman of Scientific Committee, Chinese Qigong Scientific Research Association; Professor Lu Zuyin [7120

4371 5593], Standing Director of the Chinese Biomedical Engineering Association; Professor Yang Tongtang [2799 0681 1016], Deputy Secretary General of the Chinese Biophysical Association; and Associate Professor Tao Zulai [7118 4371 5470], Standing Director of the Chinese Biomedical Engineering Association.

First Gibberella Disease-Resistant Wheat Produced

90FE0192B Beijing KEJI RIBAO [SCIENCE AND TECHNOLOGY DAILY] in Chinese 29 Apr 90 p 1

[Article by Fan Jian [5400 1696], reporter of KEJI RIBAO, and Liu Zhijie [0491 1807 2638], reporter of Xinhua News Agency: "Wheat Production From the First Scab-Resistant Variety Reported—Hopes To Restore One Hundred Million Hectares of Infected Wheatfields Rising"]

[Text] Dr. Deng Jingyang [6772 2529 2254], a renowned genetic plant breeder and the principal investigator of the national Taigu genetic male-sterile wheat-breeding project, had just recently returned from an inspection trip from an experimental wheat farm in Guangdong. In Beijing, he disclosed to reporters that the first scab-resistant hybrid variety of wheat, developed from the Taigu male-sterile gene, has been released for wheat production. This new achievement in wheat breeding clearly demonstrates our leading position in scientific research in this field.

Gibberella zeae (Schw.) or scab, is termed "cancer of wheat" by many foreign agricultural experts, because this fungal disease infects and spreads as fast as cancerous cells. To date, development of scab-resistant wheats has not been notably successful. In addition, scabbed grains are dangerous to man and to most domestic animals as well. This wheat disease is widespread in most major wheat-producing areas all over the world. It is estimated that scab infects some 1 million hectares of wheat fields in the central and lower Yangtze Valley, southern and southwestern China, as well as part of the spring wheat zone in northeastern China every year. Consequently, wheat harvests in these vast regions have been suffering various degrees of losses and in the most severe cases, yield no grains at all.

The Taigu genetic male-sterile wheat was discovered 18 years ago in Taigu County, Shanxi Province, China. It is the first known spontaneous mutant of wheat, the sterility of which is controlled by a single dominant male-sterile gene. Because of its unique genetic characteristics, this variety is very important in wheat breeding. Since 1981, members of a national multi-disciplinary research group, led by Deng Jingyang, a research scientist from the Chinese Academy of Agricultural Sciences, have devoted themselves to the extensive study of utilizing this dominant male-sterile gene in wheat breeding. In the past decade, they have cross-bred more than 40 new high-producing, disease-resistant and hazardous-tolerant varieties of wheat possessing superior agronomic characteristics. Under the supervision of the Chinese

Academy of Agricultural Sciences and in close cooperation with the Department of Agricultural Sciences at South China Agriculture University and the Institute of Wheat and Rice Research, Fujian Academy of Agricultural Sciences, they completed in March of this year a study of "Breeding of Scab-Resistant Wheat Strains Utilizing the Taigu Genetic Male-Sterile Wheat." This study is an integral part of the "Breeding Techniques for New Wheat Varieties" project which constitutes one of the key plant-breeding research programs in the Seventh "5-Year Plan." Their findings have been favorably received and approved by an evaluation panel of experts. The result of 2 years' location-screen test, conducted in some 130 hectares of wheatfields in the Yangchun County in Guangdong, show that T400, a new, scab-resistant variety, produced 13.3 to 55.7 percent more wheat than the control species. The yield reached as high as 240 to 280 kilograms per hectare when T400 was test-planted in large acreages in Jiexi, Yangchun and Xingning Counties in Guangdong.

Deng Jingyang told the reporters that the scab-resistance in wheat is controlled by multiple genes and easily affected by the environment; it is quantitatively inherited and the heritability is low. The application of Taigu genetic male sterility in resistance breeding has yielded many moderately resistant new varieties of wheat, as well as some anti-genetic and other very promising high-resistance species. Through parent-building and recurrent selection, new varieties with improved scab resistance, such as T424, T438, T531 and T592, have been obtained. This approach is designed to recombine and accumulate genes for a particular character, thereby affording varieties with most desirable traits. They have also bred a number of new wheat entries, using multiple crossing, selective breeding, single selective crossing and other techniques as well. Results of field-adaptability tests in disease-ridden areas and artificial single-flower injection test of these new species indicated that their scab-resistances are comparable or better than that of "Sumai 3," which has been considered as an excellent scab-resistance source throughout the world. Their other agronomic characteristics, such as stem height, growth period and grain weight, have been improved as well.

Dr. Deng explained to us descriptively that the introduction of scab-resistant genes into wheat greatly enhances its ability to fight off the infection of this disease; therefore it stops the infestation and spread of this "cancer" in wheat. Agricultural experts have pointed that the utilization of the domination male-sterile gene in recurrent selection is one of the most cost-effective and efficient wheat-breeding techniques. The successful development of this advanced technique can hopefully break the many bottlenecks in wheat breeding.

Because of the outstanding contributions of Chinese researchers in developing the theory and pursuing the application of the wheat male-sterile gene, the principal investigator of our national wheat-breeding project, Deng Jingyang, has recently been elected to the National Academy of Agricultural Sciences of France as a foreign member.

Qinghua University Develops Domestic Transputers

91P60019A Beijing *JISUANJI SHIJIE [CHINA COMPUTERWORLD]* in Chinese No 37, 26 Sep 90 p 1

[Article by Ke Yan [2688 1693] and Jiu Chu [0036 0443]: "Qinghua University Develops China's Own Transputer Board-Level Product Series"]

[Summary] Engineers at Qinghua University's Computer Department have developed a Transputer board-level product series: the TTH-1A (single CPU), the TTH-2A (dual CPU), and the TTH-4A (four CPUs), as well as the D700 Transputer development system. These new products, which recently passed the technical appraisal sponsored by the Ministry of Machine-Building and Electronics Industry in Beijing, are a critical part of the Key State Seventh 5-Year Plan project entitled "Microcomputer System Structure Using RISC [reduced instruction set computing] Technology" [see JPRS-CST-90-019, 23 Jul 90, pp 41-42].

The Transputer, a technologically advanced new type of processor chip, has a speed as high as 10 MIPS [million instructions per second] or 1.5 MFLOPS [million floating-point operations per second]. Because of its four high-speed I/O [input/output] channels and Occam parallel language ability, it has particular applications in high-speed parallel processing systems and multiprocessor point-to-point communications systems. Other applications include image processing, graphics, simulation, new computer system structures, pattern recognition, and neural networks. In Europe's ESPRIT research project for strategic development of information technology, applications of the Transputer are considered a critical research direction.

In China, previous Transputer board-level products have relied on imports, which are quite expensive (the T800 chip with a 2MByte built-in memory costs about US\$4,000); consequently, domestic research on and fabrication of Transputer chips is of enormous significance for the development of China's computer technology.

The technical testing has demonstrated that all of the TTH-series products can run under the IBM PC AT and compatible environments. With respect to languages, they will accept TDS, Occam II, C, FORTRAN, parallel C, parallel FORTRAN, and the Helios distributed operating system, and they are compatible with foreign-made communications software. System performance and technical indicators meet or exceed late eighties standards for similar foreign-made products. The Transputer products are currently being put into small batch production, and after production gears up, the chips will undoubtedly elevate domestic RISC technology and promote further development of applications.

State Bureau Formulates Anti-Computer-Virus Regulations for Census

91P60001A Beijing *JINGJI RIBAO [ECONOMIC DAILY]* in Chinese 27 Aug 90 p 1

[Article by Wang Xuewu [3769 1331 2976]: "State Statistics Bureau Formulates Computer-Virus Prevention and Cure Regulations to Guarantee That Census Data Processing Goes On Smoothly"]

[Summary] The State Statistics Bureau (SSB), in an effort to ensure that statistical data processing for the Fourth Census is concluded without a hitch, has—under the guidance of the Ministry of Public Security—been laboring for over a year on the formulation of "Regulations for the State Statistical System's Computer System Security and Prevention and Treatment of Viruses," the first domestic professionally oriented regulation for reinforcing oversight of computer security. SSB relies totally on computer processing of census data, and six types of computer virus—the Ball (or Ping-Pong), the Marijuana, the Jerusalem, the Pakistani Brain, the Vienna, and another—have already posed a serious threat to some of the system's nearly 10,000 microcomputers and supermicrocomputers over the past year. After having utilized virus detection and detoxification software, SSB discovered that new types of viruses and cross-infections had spread, and was forced to apply further techniques to eradicate the new viruses. Based on successful experiences at all of its offices, SSB has formulated the new regulations, which are to take effect 1 October [1990]. The new regulations, covering hardware, software use, and networked data communications, have the goal of a "virus-free" environment for census data processing.

Neural-Net Inference Engine Examined

91P60011A Chongqing *JISUANJI KEXUE [COMPUTER SCIENCE]* in Chinese No 4, Aug 90 pp 11-13

[Article by Yu Shaobo [0151 1421 3134] and Yan Junyong [0917 7165 3057] of the Computer Department, Naval Academy of Engineering, and Hu Shouren [5170 1343 0088] of the Computer Department, University of Science and Technology for National Defense: "Present, Future of Inference Engines"]

[Summary] Abstract: First, the history and present state of inference methods and the inference engine (IE) are summarized. Then, one of the important development directions—the neural-net IE—is suggested, and research on this topic is reviewed.

[Introduction]

Current research on automated inference can be broken down into three areas: non-summation methods, non-monotonic inference, and functional inference techniques.¹ In the first area, Bledson, Knuth, Boyer, and Moore have published mathematical inductive methods. McCarthy and Reiter have proposed techniques for the second area. The third area consists of

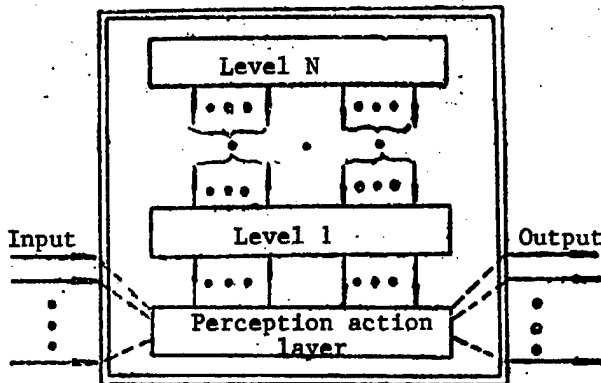

Figure 1. Structure of Neural-Net Inference Engine

probabilistic inference, fuzzy inference, and the D-S methods for degree of confidence.

I. Development of the IE

The two main indicators for judging an IE's merits are:² 1) the accuracy of selected knowledge and of knowledge put to use, and 2) the time required for solving a problem.

Since the mid eighties, researchers have implemented IE's on parallel computers in order to raise efficiency. An example is the parallel PROLOG IE. Further improvements in efficiency published in the mid to late eighties cover the topics of the massively parallel connection IE and practical associative memory techniques.⁶⁻⁹

Some of the more important topics being considered in recent research^{8,9} are knowledge representation, learning theory, the problem of low efficiency, and fault tolerant systems.

II. The Neural-Network IE

We believe, from an analysis of recent research, that neural-net IE's are the preferred direction of future research on the IE. In reference 5, we first proposed the concept of a neural-net IE. Here, we take the concept of the neural-net IE, shown schematically in Figure 1, one step further.

The neural-net IE has a multi-level structure. A perceptron in the lowest level—the perception action layer—sends the signal it receives from the stimulus in the outside world to a higher level for processing (categorization, segmentation, matching, etc.). Then, the output of the processing level is fed back into the perception action layer. Simultaneously, the signal from the higher, processing level causes the lowest layer to be more sensitive to that particular type of excitation: the so-called problem of concentrated "attention."

The neural-net IE has the following characteristics:

1. It generates "approximate" conclusions based on inquiry and its own stored knowledge; it has the power of

generalization. Its superiority is in the processing of fuzzy, imprecise knowledge.

2. Inputting can be either by application of mathematical techniques to describe the information or by a complete or incomplete information analog or model. This model will accept information such as patterns and sounds for purposes such as pattern recognition, continuous speech recognition, and target recognition.

3. The neural-net IE is an asynchronous, continuously driven system, and not merely an input-driven or query-driven system. This is to say that its inference processes go on even during periods of absence of actual input from the external stimulus.

4. The neural-net IE provides new support for inductive inference. The traditional method for studying inductive inference is from the point of view of probability theory,¹⁰ but an inductive inference based on dynamics exhibits higher potential.¹¹ The neural-net IE, on the basis of previously input information as well as stored information, can calculate future possible inputs.

5. The neural-net IE can be characterized by inherent time factors, due to the asynchronous parallel nature of its processing operations. The introduction of time factors into the subject of inferential techniques can enormously improve inferential power.¹²

6. The neural-net IE has learning abilities. Via inductive inference, it can assimilate new knowledge.

7. The neural-net IE is intrinsically capable of more than sufficient fault-tolerant performance.

References

1. Jiang Yunfei [1203 0061 7378], "Computer Automated Inference," JISUANJI KEXUE [COMPUTER SCIENCE], 1988, No 4, pp 52-55.
2. Zhang Chengqi [1728 2052 1142], "Knowledge-Based Inference," JISUANJI KEXUE [COMPUTER SCIENCE], 1988, No 6, pp 1-12.
3. Hu Shouren and Yu Shaobo, "Artificial Intelligence and Neural Networks," JISUANJI KEXUE [COMPUTER SCIENCE], 1990, No 2.
4. Yu Shaobo et al., "A Quantum Learning Algorithm for Multi-Layered Neural Network," INNC-90, Paris (accepted) [PROC. OF INNC-90, Vol 2, p 787].
5. Yu Shaobo et al., "An Initial Study of the Neural-Net Inference Engine," HAIJUN GONGCHENG XUEYUAN XUEBAO [JOURNAL OF THE NAVAL ACADEMY OF ENGINEERING], 1990, No 4.
6. J. C. D. F. Ribeiro et al., "Content-Addressable Memories Applied to Execution of Logic Programs," IEE PROC. E., Vol 136, No 5, 1989, pp 383-388.

7. W. Hibern, "Neural Networks and Conditional Association Networks: Common Properties and Difference," IEE PROC. E., Vol 136, No 5, 1989, pp 343-350.

8. S. T. Gallant, "Connectionist Expert System," COMM. OF THE ACM, Vol 31, No 2, 1988, pp 152-169.

9. Feldman and Ballard, "Connectionist Models and Their Properties," COGNITIVE SCIENCE, Vol 6, No 3, 1982, pp 205-254.

10. Jiang Tianji [3068 1131 7535], "Theory of Inductive Logic," Hunan People's Publishing House, 1987.

11. T. Oi, "Chaos Dynamics Executes Inductive Inference," BIOL. CYBERN., Vol 57, 1987, pp 47-56.

12. C. Kwong, "Representing Time," "Approaches to Knowledge Representation: An Introduction," ed. G. A. Ringland and D. A. Duce, Research Studies Press Ltd., 1988, pp 189-205.

First Domestic Reactor Process Computer System Developed

91P60021C Beijing KEJI RIBAO [SCIENCE AND TECHNOLOGY DAILY] in Chinese 28 Sep 90 p 1

[Article by Shi Jianping [4258 1696 1327]: "China's First Reactor-Process Computer System at World State-of-the-Art"]

[Summary] The "reactor-process computer system" developed by Qinghua University's Institute of Nuclear Energy on the basis of imported technology passed the technical appraisal sponsored by the State Education Commission on 26 September. The experts at the appraisal agreed that this system, the nation's first independently developed functionally complete reactor-process system—with respect to parameters, monitoring, display, and recording—meets international standards of the eighties for design and applications, and that it will be of major value in promoting safe reactor operation and technical development in China, especially in the area of industrial-scale nuclear-powered district heating.

The Qinghua University institute, which began studying applications of computers to reactor control in the seventies, has achieved computer closed-loop control of the 901 shielded test reactor. The computer system has also been applied in the world's first 5-megawatt low-temperature district heating reactor to operate continuously for 15 months (as of now). The system employs a series of advanced technologies, including an intelligent distributed data acquisition station, fully isolated digital transmission, concurrent multi-tasking software, color graphics and display, and all-Chinese-character printout.

The system operating cycle is 250 percent faster than that of conventional designs, and the utilization rate has increased to 99.99 percent.

New Hardware for Remote-Sensor Image Processing

91P60021A Beijing JISUANJI SHIJI [CHINA COMPUTERWORLD] in Chinese No 37, 26 Sep 90 p 21

[Article by Ke Wen [2688 2429]: "Image Pre-Processing System Front-End Optical-Disk Interface Board Debuts"]

[Summary] New ground reproduction equipment for multi-spectral-scanner remote-sensor image data—a front-end optical disk interface board for the image pre-processing system—was recently jointly developed by the CAS Shanghai Institute of Technical Physics and the Beijing Space Center.

Optical disk drives available on the market all use the SCSI [small computer system interface] interface as the standard data interchange interface, but the SCSI cannot be applied to high-speed processing of aerospace remote-sensor data. The newly developed system board has a 68000 CPU subsystem which can run main-control-board macrocommands sent serially. The on-board 256K DRAM memory is a shared storage space for the optical-disk data buffer and for pre-processing system data. The system is designed to provide 500Mbytes to 5000Mbytes of memory and data rates of 160Kbytes to 1Mbyte per second, suitable for remote-sensor real-time data processing and storage.

Vehicle-Mounted Computer Radio Communications Network Developed

91P60021B Beijing JISUANJI SHIJI [CHINA COMPUTERWORLD] in Chinese No 37, 26 Sep 90 p 21

[Article by Fu Sijing [0102 1835 2417]: "Beijing Institute of Water Conservancy Automation Develops Vehicle-Mounted Computer Wireless Communications Network"]

[Summary] After having developed a "microcomputer ultra-short-wave radio telecommunications network" last year, the Beijing Municipal Institute of Water Conservancy Automation recently announced the development of a "vehicle-mounted mobile computer wireless communications network," consisting of LP-286 portable computers and vehicle-mounted duplex or semi-duplex voice-circuit transceiver equipment, including hardware communications card inserts and communications software designed by the institute. Data transmission speed is 1200 bits per second, and the number of on-network stations can be varied from 2 to 200. The system can handle digital speech without conversion and is therefore ideal for field use in a variety of disciplines, including mineralogy, petroleum exploration, cartography, public security, transportation, and the military.

Developments in Robotics Reported**Pressure-Vessel Crack-Detection Robot**

91P60002A Beijing KEJI RIBAO [SCIENCE AND TECHNOLOGY DAILY] in Chinese 1 Sep 90 p 4

[Article by Tie Ping [6993 1627]: "High-Pressure-Vessel Crack-Detection Robot"]

[Summary] The GD-1 series of high-pressure-vessel non-destructive crack-detection robots, developed by the Air Force No 1 Research Institute, has passed its technical appraisal. These computer-based robots, designed to detect fatigue cracks and stress corrosion on inner and outer surfaces of high-pressure vessels, have a detection-point repeat accuracy of plus over minus 1 millimeter and a high sensitivity for surface cracks (down to 0.01 millimeter wide and 0.2 millimeter deep). They are intended to detect surface flaws both in quartz pressure vessels and in vertical pressure vessels.

Shenyang R&D Center Accredited

91P60002B Beijing KEJI RIBAO [SCIENCE AND TECHNOLOGY DAILY] in Chinese 2 Sep 90 p 1

[Article by Liu Xianda [0491 7359 6671]: "CAS Shenyang Robotics Demonstration Project Passes State Acceptance Check"]

[Summary] Shenyang, 1 Sep—The nation's first specialized research and development base for robotics technology—the Chinese Academy of Sciences' (CAS) Shenyang Robotics Demonstration Project—officially passed state acceptance check a few days ago. Early plans for this state-of-the-art R&D center for robotics engineering were conceived by Chinese officials in 1982, construction formally began in July 1986, various laboratories became operational one after another beginning in January 1989, and the last of these laboratories has now been completed. State investment for the 34,000-square-meter-plus R&D center, which consists of 12 labs and one testing plant for prototypes, totaled 58.774 million yuan, and imported equipment cost US\$5.9 million in foreign exchange. The underwater robots developed by center researchers, who are also part of the CAS Shenyang Institute of Automation, are considered world-class and are now being sold on the world market.

Zou Jiahua at R&D Center Ribbon-Cutting

91P60002C Guangzhou NANFANG RIBAO in Chinese 3 Sep 90 p 3

[Article by Dong Jianzhen [5516 6432 4176]: "Shenyang Robotics Demonstration Project Construction Completed"]

[Summary] Shenyang, 2 Sep 90 (XINHUA)—State Councillor and Minister in charge of the State Planning Commission Zou Jiahua today made a special appearance at the ribbon-cutting ceremony marking the official completion of the CAS Shenyang Robotics R&D Center.

After the ceremony, Minister Zou with great zest watched demonstrations given by robotics researchers, especially a demonstration at the Underwater Robotics Laboratory of a 1-meter-long "Little Goldfish" underwater robot, which has two bright "eyes" [for receiving imagery] on its head and which can operate on the ocean bottom at depths of up to 100 meters.

First Domestic Underwater Robots on World Market

91P60002D Beijing KEJI RIBAO [SCIENCE AND TECHNOLOGY DAILY] in Chinese 5 Sep 90 p 1

[Article by Yuan Youling [5913 1635 7190] and Huang Yong [7806 0516]: "Underwater Robots Developed in China Enter International Market"]

[Summary] A mid-sized underwater robot independently developed in China arrived a few days ago in the United States—this is the first domestically-manufactured underwater robot to enter the international market. This type of robot is one of three types of mid-sized underwater robots developed by the CAS Shenyang Institute of Automation as a key project in the state's Seventh Five-Year Plan. The first type has been licensed by bid to a foreign company for service in the South China Sea for over a year, and the third type will soon be employed in the Bohai Sea to salvage a Japanese ship, after which the robot will be granted state accreditation.

The type now entering the world market is the second type developed by the CAS institute. This type, an improvement upon the "Hairen-1" ["Seaman-1," abbreviated HR-1; see JPRS-CST-90-022 29 Aug 90, p 31] experimental underwater robot, was developed over a 3-year period with the aid of technology imported from the United States. It has a closed-loop direction-control system, a propeller with 180 percent more thrust than the HR-1, a payload of 160 kilograms (compared to 114 kilograms for the HR-1), and a speed of over 3 knots (compared to 2.5 knots for the HR-1).

United States firms have given the Chinese-manufactured mid-sized underwater robots a very high appraisal. The CAS Institute of Automation spokesman added that the institute can also produce small-size and large underwater robots, and—according to domestic or foreign contract requirements—can provide an underwater robot to desired specifications within 24 weeks.

Nuclear Power Plant Maintenance Robot

91P60002E Beijing CHINA DAILY in English 17 Sep 90 p 3

[Caption to photograph by Zheng Yongji]

[Text] A 6-foot robot designed for maintenance work in nuclear stations is under examination in the Shenyang Robot Engineering Research and Development Centre in Shenyang. The centre, the country's first, has 11



laboratories and took 33 months and an investment of 50 million yuan (\$10.6 million) to build.

Robots Will Operate Assembly System

*91P60002F Beijing CHINA DAILY (Shanghai Focus)
in English 17 Sep 90 p 1*

[Article by Zhong Chen: "Robots Will Operate Assembly System"]

[Excerpts] Shanghai is setting up an experimental assembly system operated by robots. It will be used in manufacture of small and medium mechanical and electrical products.

The system adopting technology from the United States, aims to show enterprises that many products can be assembled on the robot-operated automatic line, said Jiang Houzhong, director of the Robot Institute of Shanghai Jiaotong University.

The institute introduced an "intelligent" robot from America's Adept Technology Incorporation at a cost of \$120,000.

"The establishment of the system will be vital to promoting the wide use of the robot-operated automatic assembly," said the director.

[Passage omitted]

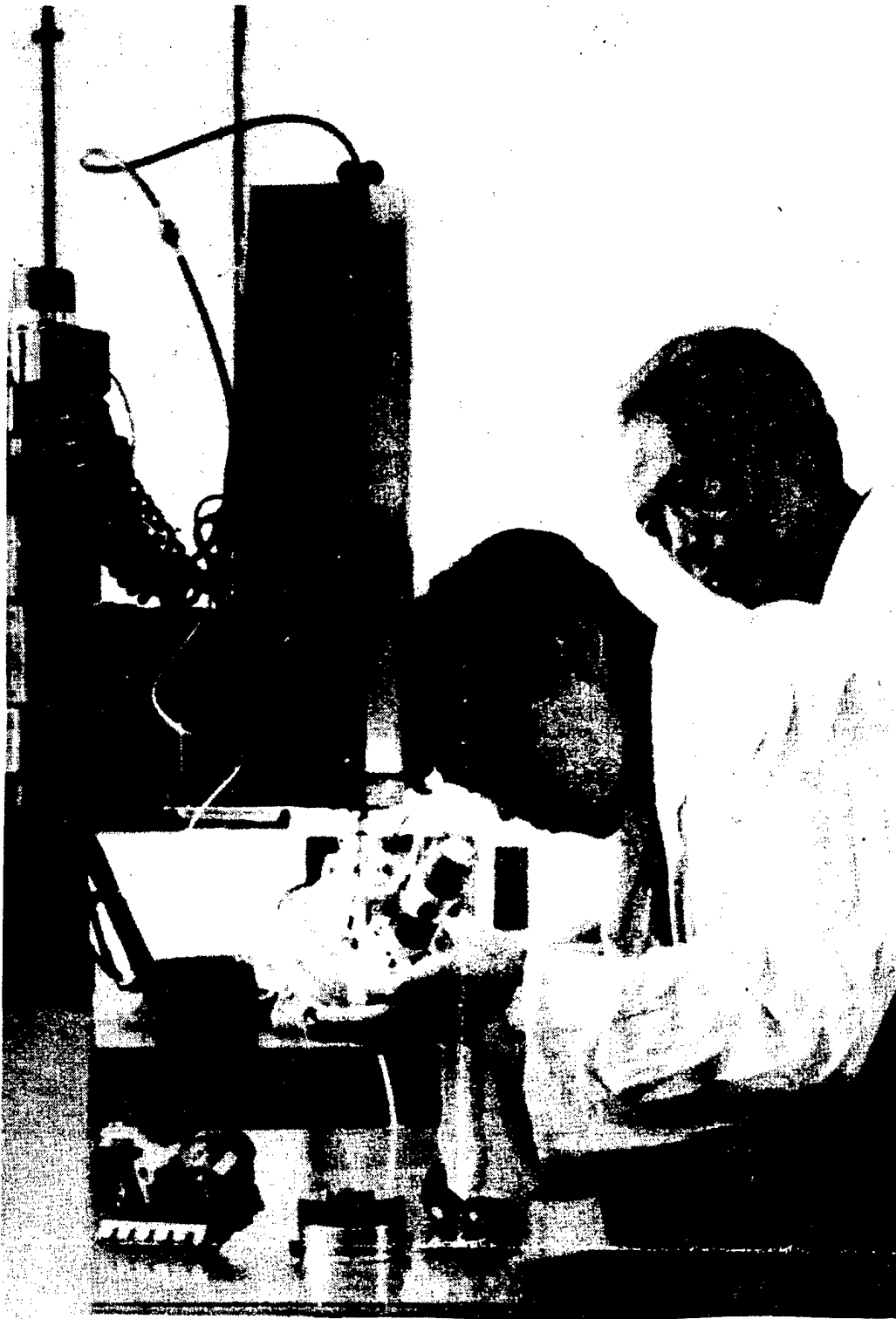

Scientists from the Shanghai Instrument Factory study a new generation of robots.

The system can be used to weld, spray paint and assemble to ensure the quality of the products. No longer will quality control be effected by workers' moods and physical fatigue.

[Passage omitted]

The country is developing three kinds of robots: assembly robots in Shanghai, underwater robots in Shenyang and robots capable of working under adverse conditions in Changsha.

The city began researching robots in the end of 1984 with the help of 1.3 million yuan from the local government. A special team was set up to develop arc welding industrial robots and spray painting industrial robots.

Two years of effort led to the birth of Shanghai Robot-I for arc welding using advanced foreign technology.

The Robot-II for loading and unloading was introduced in the city's Industrial University, while the Robot-III for spray painting was developed at Jiaotong University.

At the moment, the city has seven scientific groups engaged in research and design.

"But it is a pity that enterprises find it difficult to use robots on the production line because they are so expensive," he said.

The local science and technology commission recommends investing more than 200,000 yuan to improve the robot to make it commercially viable.

At the moment, the university is cooperating with the Free University of Brussels in Belgium on research of high-level robotized assembly language, a kind of assembly software.

The software, which will be debugged in Brussels at the beginning of next year, is a key part of the experimental assembly system.

More on Nuclear Plant Robot

91P60002G Beijing CHINA DAILY in English
1 Oct 90 p 3

[Article by Ji Ren: "Shenyang Pioneers Robot Development"]

[Excerpts] To scientists at the Shenyang Robot Demonstration Centre, it is a "six-legged, all-directional walking robot, with anthropomorphic articulated manipulator."

To the visitor, it looks like a slightly leggier version of "R2D2," the endearing mechanical hero of the film "Star Wars."

Its six metal legs seem perfectly coordinated as it plods along, climbing several steps and then navigating around a wooden obstacle.

Remote controlled, the robot can travel 15 metres per minute, climb a 35-degree slope, and carry as much as 200 kilograms. It is designed to do delivery, testing, and maintenance work in dangerous environments such as nuclear power stations.

[Passage omitted]

Supported by the Shenyang Institute of Automation under the Chinese Academy of Sciences, the centre was pinpointed as a key construction project in the Seventh Five-Year Plan (1986-1990).

Construction took only 33 months, during which research began at other facilities. The centre has since absorbed 23 other high-tech projects designated under the State's "March '86" programme.

[Passage omitted]

The Underwater Lab, a separate structure several metres away from the main building, has its own full-size testing pool. So far, it has developed three generations of robots for underwater use, all controlled by cables.

"We are now working on untethered robots which react to their environment and make decisions on their own," said Feng Xisheng, deputy head of the lab. Such intelligent robots require complex control systems and probably will not be applied widely in China until the mid-1990s, he said.

Optical Full Adder Composed of a ZnS Interference Filter

90FE0288B Shanghai ZHONGGUO JIGUANG
[CHINESE JOURNAL OF LASERS] in Chinese
Vol 17 No 2, Feb 90 pp 120-122 [MS Received
31 October 1988]

[Article by Zha Zizhong [2686 1311 1813], Wang Ruibo [3769 3843 3134], Zhang Lei [1728 7191] and Li Chunfei [2621 3196 7378] of Applied Physics Department, Harbin Institute of Technology: "Optical Full Adder Composed of a ZnS Interference Filter"]

[Text] Employing a ZnS interference filter as an optical bistable device, a single gate optical full adder is demonstrated, and the design of a binary multi-bit optical adder is presented for the first time.

1. Single-Gate Optical Full Adder Composed of a Bistable Device

F. A. P. Tooley¹ employed a ZnS interference filter as an optical bistable device to create an optical full adder. Because the full adder is composed of a bistable device, both reflected and transmitted light are utilized. Moreover, it has a simple structure. However, because as oblique incidence mode is used for signal input, it is not suitable for integration and concatenation. In this experiment, normal incidence is used for signal input. Therefore, this scheme has a simple structure and is suitable for integration and concatenation as well. The experiment setup is shown in Figure 1. In the figure: Ar⁺ - argon ion laser, Wavelength $\lambda = 514.5$ nm, M - light intensity modulator, A - light intensity attenuator, P - polarizing prism, O - objective lens of microscope, Q - $\frac{1}{4}$ wavelength plate, IF - ZnS interference filter, D₁ and D₂ - optical detectors.

Detector D₁ receives light reflected by IF. Its output signal represents this digit and S_i. Detector D₂ receives light transmitted through IF. Its signal represents the carry over to the next digit C_{i+1}. In order to make the input and output signals (including reflective and transmissive output) of IF fully reflect the logic functionality of the truth table of a full adder, the intensity of the input laser beam must be modulated. A simple light modulating disk was made to modulate the intensity of the input laser beam into four signals of different intensity, as shown in Figure 2. In the figure, I₀ - lowest input light intensity (or 0) which represents the situation that the full adder input signals A_i, B_i and C_i are 0, I₁ - representing the situation that one of A_i, B_i, or C_i is 1 and the rest are 0, I₂ - representing the situation that two of A_i, B_i, and C_i are 1 and one is 0, and I₃ - representing the situation that all of A_i, B_i and C_i are 1. Except for I₀, the intensities of the other three input signals have the following relation I₂ = 2I₁, I₃ = 3I₁. The optical bistable device should ensure that the output signals can satisfy the logic relation in the truth table of the full adder with the four input signals shown in Figure 2. Furthermore, there ought to be sufficient contrast (i.e., enough difference in amplitude between "0" and "1"). Figure 3 shows

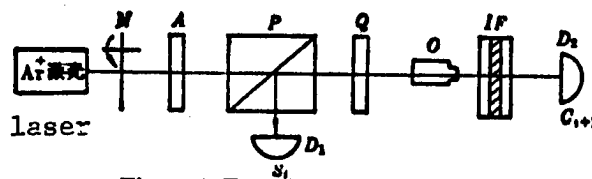

Figure 1. Experimental Apparatus

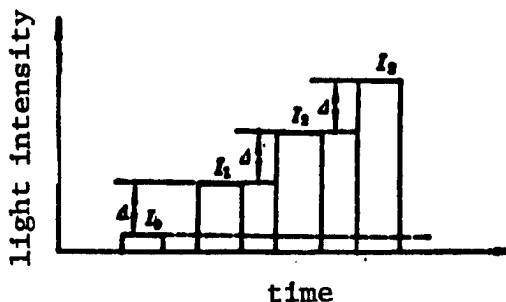

Figure 2. Modulated Input Signal

the operation of the optical bistable device. (a) is the reflective curve of bistability and (b) is the transmission curve. I_i, I_R and I_T represent the intensity of input, reflected and transmitted light, respectively. From Figure 3, when the input intensity is I₀, it has not reached the threshold for bistability. Both reflected and transmitted light are low. I_T and I_R are located at point A and A', respectively. At this time, S_i = 0 and C_{i+1} = 0. When the input intensity is I₁, it still has not reached the threshold for bistability. I_T and I_R are located at point B and B', respectively. However, because input light intensity is increased, reflected light intensity is high and transmitted intensity is still low. At this time, S_i = 1 and C_{i+1} = 0. When the input light intensity is I₂, I_T and I_R are located at point C and C', respectively. At this point, I₂ has reached bistability and I_T is high and I_R is low. At this time, S_i = 0 and C_{i+1} = 0. When the input light intensity is I₃, I_T and I_R are located at point D and D', respectively. I₃ is still over the threshold and I_T remains high. Due to increased input light intensity, I_R is also high. At this time, S_i and C_{i+1} = 1. Therefore, when operating in the above modes, the input/output relations of the bistable device can meet all the logic relations in the truth table.

Figure 4 shows the experimental results. From the picture, the input/output relations of the full adder can satisfy the logic relations in the truth table with excellent contrast. Because of using a normal incidence mode, the operating mode of the bistable device cannot be controlled by adjusting the amount of initial mismatching. The only way is to select a ZnS interference filter that fits the operating characteristics shown in Figure 3 out of many as the bistable device. This is less than desirable.

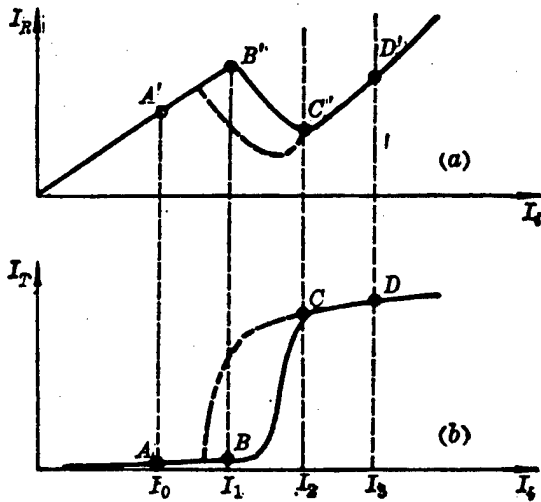

Figure 3. Operating Modes of the Optical Bistable Device

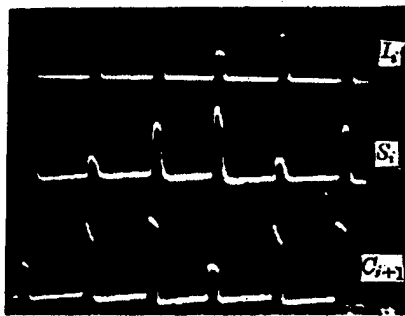

Figure 4. Experimental Picture

II. Binary Multi-Digit Optical Full Adder

The single-gate optical full adder described above can only add up two digit binary numbers. However, based on the concept of using an optical bistable device to make a single gate optical full adder, it is also possible to fabricate several single gate full adders with an interference filter. Figure 5 shows an experimental scheme for an optical adder for four digit numbers; where Ar⁺ - argon laser with direction of polarization parallel to the optical axis of the polarizing prism, S - space beam adjuster, A₁-A₄ - opto-acoustic modulators, B - beam splitter, P - polarizing prism, Q₁, Q₂ - 1/4 wave plates, IF - ZnS interference filter, M₁-M₃ - total reflective mirrors. It operates as follows. The space adjuster splits the laser into four parallel beams. Each beam is modulated by an opto-acoustic modulator into signals of two different

intensities (I₂I₁). I₁ represents the situation that one of the input signals A_i or B_i and the other is 0 and I₂ represents the situation that both A_i and B_i are 1. When the opto-acoustic modulator has no output, it represents the situation that both A_i and B_i are 0. Each beam transmitted through the interference filter represents a carry over signal and is added to the input end of the next digit through M₁, M₂ and M₃. The light reflected by IF passes through the polarizing prism and is received by five detectors. They represent the result of the addition of two four-digit binary numbers. This number can be displayed after opto-electronic conversion. The two four-digit binary numbers are entered from the keyboard of a computer. The four opto-acoustic modulators are controlled by the computer to ensure that I₂ [g | I₁. The polarizing prism and the 1/4 wave plates are there to change the direction of polarization of the beam. In order to allow the carry-over signal to add to the input signal of the next digit in a synchronous manner, the input pulse which should be greater than the delay time of the bistable device. This scheme is a serial carry-over and parallel addition full optical adder. The advantage of the scheme is that it only takes an interference filter to realize the addition of multi-digit binary numbers (e.g., 4-digit, 8-digit, etc.). It is somewhat integrated and is simple in structure. The light beams reflected and transmitted by the bistable device are fully utilized to perform parallel optical operations. The disadvantage is that the input signal and the carry-over signal are overlapping each other on the beam splitter, resulting in a large loss of optical energy (approximately 50 percent). If optical fiber is used for light transmission and light signals are overlapping at an optical fiber coupler, optical energy loss might be reduced. In addition, it requires an opto-acoustic modulator to regulate the intensity of each beam. For a multi-digit full adder, the overall structure is too bulky. However, there are ways to resolve this problem. Nevertheless, it is feasible to use an interference filter or a non-linear F-P cavity to make a multi-digit optical full adder.

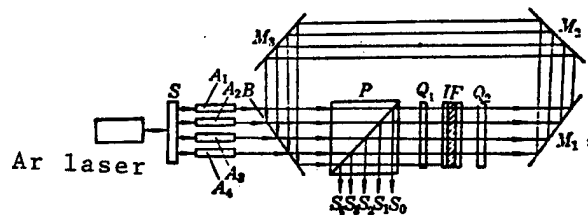

Figure 5. Scheme of an Optical Full Adder for 4-Digit Binary Numbers

References

1. F. A. P. Tooley et al., Opt. Commun., 63, 365 (1987).

Study of 40 W Copper Vapor Lasers

90FE0288A Shanghai ZHONGGUO JIGUANG
[CHINESE JOURNAL OF LASERS] in Chinese Vol 17
No 2, Feb 90 pp 118-119 [MS Received 3 May 1988]

[Article by Tao Yongxiang [7118 3057 4382], Liang Baogen [2733 1405 2704], Yin Xianhua [1438 2009 5478], Cui Jianli [1508 0256 0500] and Chen Lifei [7115 5461 5481] of Shanghai Institute of Optics and Fine Mechanics, the Chinese Academy of Sciences: "Study of 40 W Copper Vapor Lasers"]

[Text] I. Smilanski^{1, 2} and Anderson and B. E. Warner³ first operated copper vapor lasers with a mean power output in excess of 20 W on large diameter devices and proved that over 50 W of output power could be achieved by a tube diameter ratio method. Due to its high repetition frequency (5-15 kHz), green (510.6 nm) and yellow (578.2 nm) emitting wavelengths, and short pulse width (approximately 30 ns), copper vapor laser has great potential in applications such as laser isotope separation, combustion study, underwater research, photography and holography, semiconductor manufacturing, fingerprint identification and medicine. This paper reports the results of a study on a 40 W copper vapor laser.

I. Laser Structure and Discharge Circuit

The laser structure is schematically shown in Figure 1. High temperature metal electrodes and a high purity ceramic discharge tube (35 mm inner diameter x 1000 mm in length) are placed coaxially to form a discharge chamber. The copper vapor source, pure copper, is

placed inside the discharge tube. Outside the tube, a layer of aluminum oxide ceramic fiber is used as an insulation layer. Outside the insulation layer is a quartz tube. Outside the quartz tube is a stainless steel jacket which serves as a current jacket during discharge to minimize induction in order to increase the rising speed of the discharge current pulse. In order to prevent breakdown discharge between the quartz tube and the current jacket and to further improve thermal insulation of the discharge tube from the external environment, the space between the quartz tube and the current jacket is pulled to 10^{-2} - 10^{-3} Torr vacuum. The resonance cavity is composed of a concave mirror ($R = 5000$ mm) and a flat mirror located 1750 mm apart.

In the laser discharge circuit, a 6 nf capacitor is used for energy storage and a 1 nf capacitor is used for pulse sharpening. A 4050 thyatron is used as the switch. The repetition frequency of pulsed discharge is 5-8 kHz. The discharge voltage is 10-16 kV. The mean electric power is 4.5-6 kW.

II. Experimental Results and Discussion

When 15-30 Torr of Ne was used as a buffer, operating at a repetition frequency of 5-7 kHz and a discharge voltage of 12-16 kV, the maximum mean power output was 41 W, corresponding to 0.7 percent efficiency. Figure 2 shows the laser efficiency curve. With increasing input power, the wall temperature of the discharge tube also

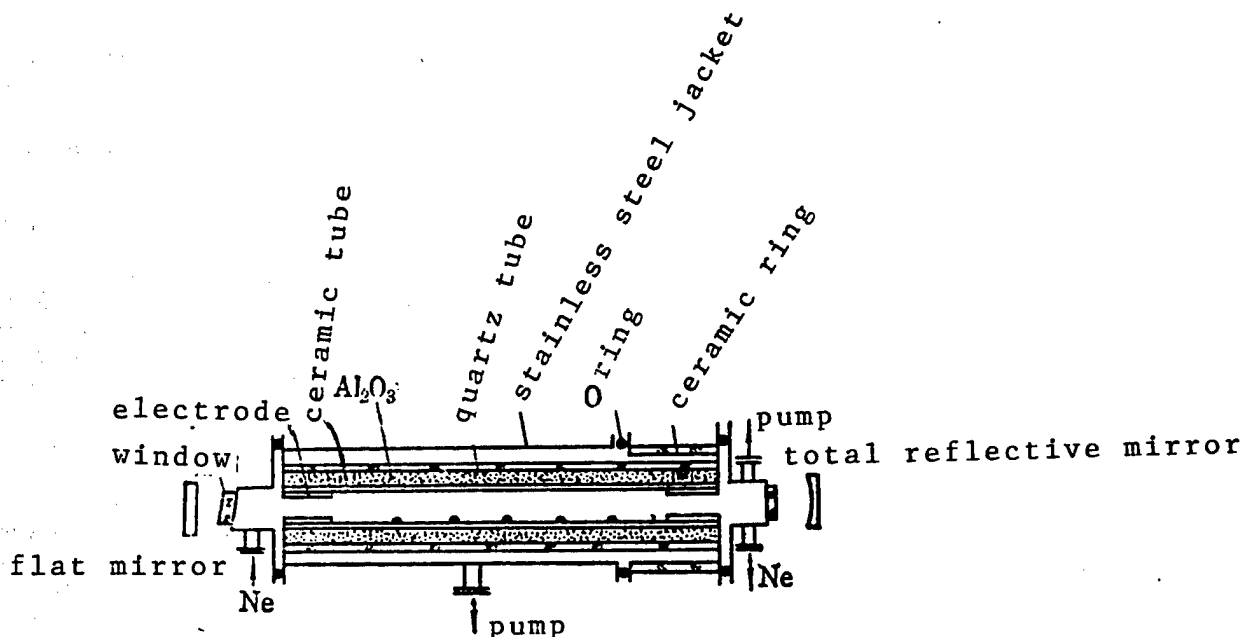

Figure 1. Structure of the 40 W Copper Vapor Laser

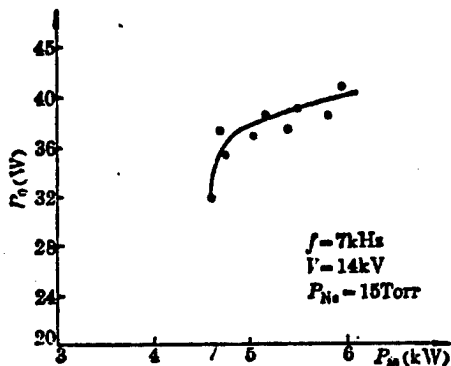

Figure 2. Laser Output Power P_o vs. Input Power P_{in}

risers and the copper vapor density also goes up. Consequently, the laser output power also increases. An optical electronic high temperature probe was used to measure the inner wall temperature. It was found to be 1450°C at 6 kW input. This indicates that the device essentially operates under a "negative" high temperature state.

2. At a fixed input power ($P_{in} = 5.5-6.0$ kW), the output power of the laser decreased significantly with increasing Ne buffer gas pressure (see Figure 3). The primary reason for the laser output power to fall with increasing Ne pressure is that the rate of collision between electron and Ne atom also increases, causing the peak electron temperature of copper atom to drop. In addition, an increase in Ne pressure will also reduce the current pulse peak height and broaden its width. An increase in electron density will also raise the super elastic collision rate in

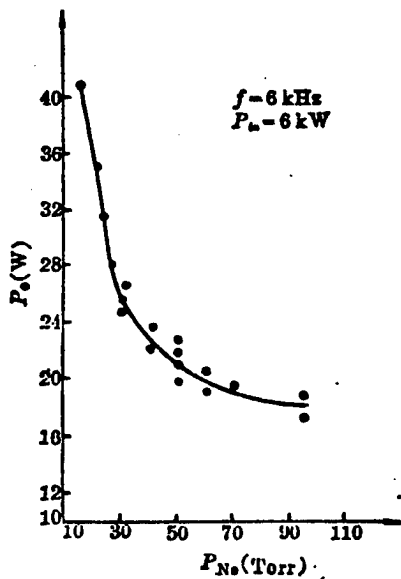

Figure 3. Laser Output Power P_o vs. Ne Pressure P_{Ne}

the plasma column which makes the density of metastable atoms go up. This is another reason for the laser power to fall.

3. Due to the cold end effect of the discharge tube, there is an apparent axial gradient dn/dx for copper vapor. Hence, it diffuses toward the ends. At $P_{Ne} = 25-30$ Torr and $P_{in} = 6$ kW, the windows on both ends of the laser showed obvious contamination after accumulating 100 hours of operation. Compared to new clean windows, the transmittance fell significantly at both operating wavelengths. This would cause the output power to fall considerably.

4. The characteristic output ratio of yellow (578.2 nm) to green (510.6 nm) is 3.6:6.4. The diameter of the laser beam is 33 mm, beam divergence angle is [h]10 mrad, pulse width is about 30 ns, and peak power is about 230 kW. Long term operation (over 100 hours) shows that further improvements are needed to optimize the structure and parameters of the thermal insulation layer, the electrical coupling efficiency between the power supply and the discharge tube, the staining of the window and the quality of the beam.

References

1. I. Smilanski et al., *Opt. Commun.*, 25, 79 (1978).
2. I. Smilanski et al., *Opt. Commun.*, 30, 70 (1979).
3. B. E. Warner et al., in *CLEOS*, 26-28 February 1980, Digest of papers (Opt. Soc. of Am., Washington D.C.), 90 (1980).

Nation's First Picosecond Autotuning Parametric Laser Developed

91P60012A Shanghai GUANGXUE XUEBAO [ACTA OPTICA SINICA] in Chinese Vol 10 No 7, Jul 90 p 617

[Article by Yi Min [0044 3046]: "China's First Picosecond Autotuning Parametric Laser"]

[Text] The picosecond autotuning parametric laser developed by the Chinese Academy of Sciences' (CAS) Shanghai Institute of Optics and Fine Mechanics passed the technical appraisal given by an expert group from CAS on 2 April 1990. This laser is pumped by the second harmonic (0.532 μ m wavelength) of a mode-locked Nd:YAG [neodymium:yttrium aluminum garnet] monopulse laser.

The system utilizes the nonlinear crystal Mg:LiNbO₃ [magnesium:lithium niobate] to generate the parametric effects. Like LiNbO₃, this crystal has a relatively high nonlinearity coefficient, no deliquescence, and is low in cost. In addition, it overcomes the vacancy and low power failure threshold phenomena seen near the consolidation point [i.e., the point at which one band is annexed or incorporated into another band] during phase matching of LiNbO₃ crystal at room temperature.

The laser uses a pair of Mg:LiNbO₃ crystals and is tunable in the range 0.7-2.2 μm . Repetition frequencies are 1, 2, 5, and 10 pps [pulses per second]. Pulse width is less than 30 ps [picoseconds], peak power is 0.1-1 MW [megawatt], spectral width is less than 2 nm [nanometers] (about 4 nm near the consolidation point), and wavelength automatic control accuracy is better than 1.5 nm. This first domestic picosecond autotuning parametric laser functions as a wide-range-wavelength scanning infrared ultra-short-pulse light source.

Microwave-Excited kW CO₂ Laser for Modern Industry

90FE0211A Beijing WULI [PHYSICS] in Chinese
Vol 19 No 4, Apr 90 pp 212-215

[Article by Zhang Zebo [1728 3419 3258] of the Institute of Physics, Chinese Academy of Sciences and Sun Shuqin [1327 3219 3830] of the Institute of Photosensitive Chemistry, Chinese Academy of Sciences: "The Multi-Purpose Industrial Tool—Microwave-Excited kW-Level CO₂ Laser"]

[Text

Abstract

The key to developing higher-power CO₂ lasers for industrial use is to further increase the power injection density for gas discharge. To this end, a modified Magic T microwave discharge chamber was developed to overcome the inhomogeneous problem caused by the high-frequency skin effect to achieve a more or less uniform microwave glow discharge in a large volume. Experimentally, it was used to excite a high-power CO₂ laser which resulted in a laser power output in excess of 1 kW. The opto-electric conversion efficiency is over 25 percent. For the first time, it has reached a commercial level.

I. Status of Industrial High-Power CO₂ Lasers

The high-power CO₂ laser is no longer just an important tool in basic research.¹ It is widely used in modern industries. For instance, significant improvements in efficiency and quality have been noted after using a high-power CO₂ laser in cutting materials, welding and surface treatment.^{2,3} In some processes, such as welding of automobile chassis and transmissions, the high-power CO₂ laser has become indispensable. In cutting and welding copper and aluminum alloys, thick steel plates and other hard metals, the CO₂ laser output power is required to reach several thousands or even tens of thousands of watts in single, or lower-order modes. The laser beam must be able to be modulated and has the capability to provide a huge pulse. As a production tool, it needs to be compact, convenient to use, safe and reliable. The key issue is the gas discharge characteristics, i.e., whether it is capable of sustaining a large-volume uniform glow discharge at a high energy injection density. This is because high-power laser output can only be obtained if the small-signal gain and saturation intensity of the laser also increase with rising injected

power density. In addition, there is an optimal electric field to gas pressure ratio, E/P, for gas discharge in a CO₂ laser. Therefore, as the power injection density increases, the optimal operating pressure also rises. Thus, with the same discharge volume not only a higher laser power output can be obtained but also the circulating pump volume can be reduced to lower cost by further reducing the volume. Continually increasing power injection density and operating gas pressure is still an attractive approach for further research.

The commonly used discharge methods are dc and radio-frequency (rf) excitation. It is difficult to maintain a steady glow with dc discharge, regardless of whether it is longitudinal or transverse. Although the discharge characteristics could be significantly improved by keeping the gas in a turbulent state at a high flow rate,^{4,5} when power injection density exceeds $1.1 \times 10^7 \text{ W/m}^3$, discharge becomes unstable. It begins to behave as an arc. Therefore, commercial dc excited high-power CO₂ lasers are operating at low power injection density and low operating pressure. They are usually bulky. In recent years, in order to raise the power injection density, the rf discharge technique has been perfected. A great deal of progress has been made in high-power CO₂ lasers excited by rf.⁶ Because of higher discharge frequency, power injection density has far exceeded that of dc excitation. It has reached $3 \times 10^7 \text{ W/m}^3$. Capacitive coupling is most often used in rf discharge. It has a low voltage and is easier to modulate and provide a huge pulse. The power of commercial rf-excited CO₂ lasers has reached 8 kW. Its modulating frequency can be as high as 100 kHz. The huge pulse amplitude is four times that of the mean power. Nevertheless, rf excitation also has its disadvantages. A high-efficiency, high-power solid-state rf source is still fairly expensive and only a few big companies can produce it. The coupling mechanism is complicated; there is still a voltage drop effect at the electrode. Radially, the discharge is still non-uniform. It cannot yet completely replace all the existing dc-excited CO₂ lasers.

Recently, because microwave ovens are being produced in large quantities, the quality of microwave sources has been significantly improved. They are more than 70 percent efficient and their cost is extremely low. Therefore, microwave discharge becomes attractive again. Besides all the advantages associated with rf excitation, microwave excitation, because its operating frequency is more than two orders of magnitude higher than rf allows power injection density to increase further, has no voltage drop at the electrode, and does not require a current-limiting resistor. Therefore, its discharge efficiency is higher. Furthermore, the commonly used magneto has a narrow operating voltage range which makes modulation and huge pulse generation easy. Since the advent of lasers, researchers have been studying the excitation of various gas lasers with microwave. From He-Ne to excimer lasers,^{7,8,9} laser beam output has been observed. However, most discharge activity took place near the surface due to a high-frequency skin effect. The laser efficiency was very low. The work was finally

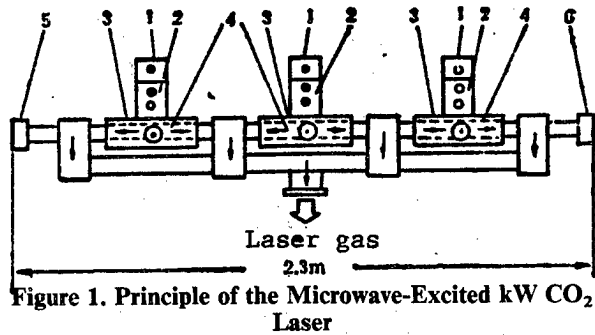

Figure 1. Principle of the Microwave-Excited kW CO₂ Laser

Key: 1. Magnetron 2M196 2. Impedance-matching device 3. Magic T discharge chamber 4. Glass discharge tube 5. Total-reflection mirror 6. Output lens

stopped. The best result was obtained at the FRG's Institute of Astronautics using a gas nozzle technique.⁹ The microwave discharge took place behind the nozzle and was no longer limited at the surface. In their CO₂ laser experiment, an output of 360 W was obtained. However, the discharge was still not uniform in the direction of gas flow. The efficiency is only 7 percent, far lower than the results with dc and rf excitation.

Recently, through theoretical and experimental studies, we recognized that the skin effect associated with microwave-excited gas discharge is a dynamic process. The skin rate is a function of microwave power injection density, electromagnetic field distribution, gas flow velocity and ionization state of the gas [see Zebo Zhang, Dissertation, University of Duesseldorf, 1988]. Under certain conditions, it is controllable. On the basis of a great deal of theoretical and experimental studies, we used a modified Magic T discharge chamber with special dimensions to achieve a large-volume uniform glow discharge under a fast flow condition. When this was applied to CO₂ laser excitation, the output laser power exceeded 1 kW. The electro-optical conversion efficiency is over 25 percent. This is better than results obtained by dc and rf excitation. For the first time, it is at a commercial level.

II. Experimental Apparatus

The experimental apparatus used to demonstrate the principle is shown in Figure 1. It includes three independent discharge units. Each unit consists of a NEC 2M196 magnetron, an impedance-matching device with two screws, and a Magic-T-type discharge chamber made of high-quality glass (Duran) and aluminum. The operating frequency of the magnetron is 2145 GHz and its efficiency is 70 percent. The three units share a gas circulating system. The gas circulating pump is a Roots pump which has a pumping rate of 2000 m³/h. There is a water-cooled heat exchanger before and after the pump. After the pump, there is a gas reduction catalytic converter. The entire system may be closed during operation, or may have certain fixed amounts of gas exchange. Each unit has a discharge length of 0.28 m. The diameter of the discharge tube is 0.024 m. The overall length of the optical resonance cavity is 2.3 m. The curvature of the molybdenum mirror is 20 m. The transmittance values of the ZeSe output lens are 0.2, 0.3 and 0.5. All optical elements and tubes are fastened on a granite platform and are all water-cooled.

The power supply is simple, low-cost, steady and reliable. As shown in Figure 2, it consists of three microwave-oven power supplies and three diodes for isolation. Because of using magnetic saturation and having a voltage doubler rectifier with certain capacitance, not only the rated power of the magnetron is ensured but also the stability requirement of the magnetron is met. Each of the three power supplies takes one of the three phases and they operate jointly to provide power to the three magnetrons. At rated power, the output microwave fluctuates very little. Thus, the long- and short-term stability of the laser output can be ensured. There is no need for additional protective measures. It works steadily over long periods of time.

III. Experimental Results

Based on a calculation using microwave discharge parameters associated with CO₂ laser and on experimental data, we designed and constructed a modified

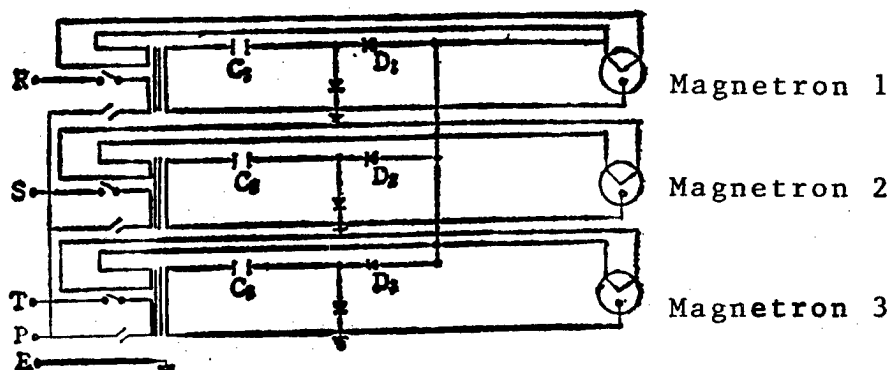

Figure 2. Schematic Diagram of the Power Supply

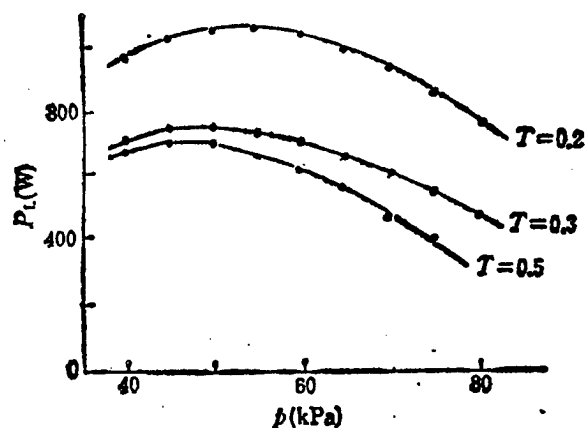

Figure 3. Laser Power Output vs. Operating Pressure

Magic-T-type discharge chamber with specific dimensions. Moreover, it also employs a gas flow pattern of a certain shape. An axial spiral flow is superimposed on top of a turbulent flow. The microwave-excited gas discharge fills the tube uniformly and no longer sticks to the walls. In addition, the radial flow further facilitates the coupling of laser output because the mode volume is generally smaller than the discharge volume. The total power output of the three microwave tubes is 4050 W. By adjusting the two screws on the impedance-matching device, approximately 95 percent of the microwave power can be coupled to the plasma. Near the optimal operating pressure, there is no need to match the impedance over a relatively wide pressure range. This is consistent with the result obtained from calculation that the impedance of the plasma essentially remains invariant in this region. This is very convenient in practice. In this experiment, a standard laser gas was used. Its composition is $\text{CO}_2/\text{N}_2/\text{He}:4.5/3.5/82$. Figure 3 shows the laser power output as a function of operating pressure at the rated microwave power (i.e., 4050 W). When the discharge tube diameter is 0.024 m, the laser beam appears in lower-order modes. The three curves were obtained when the transmittance values of the lens

Figure 4. Concentrations of CO_2 and O_2 and Laser Power Output vs. Time

Figure 5. Laser Power Output vs. Time With Catalyst

are at 0.2, 0.3 and 0.5, respectively. When transmittance T is 0.2, the maximum laser power output is 1050 W. The pressure at this time is 5 kPa and the electro-optical conversion efficiency is over 25 percent. If the transmittance of the output lens can be further optimized, higher output power is possible.

During the experiment, the composition of the gas was analyzed using a quadrupole mass spectrometer. The result indicated that the amount of dissociated CO_2 molecules is far less than that during dc excitation. The stability of laser power output is also better higher than that of dc excitation.¹⁰ Only one unit is used during discharge. This is consistent with the condition stated in reference in [11]. A few minutes after circulation shutdown and microwave discharge, the concentration of dissociated CO_2 is stabilized at approximately 30 percent. The laser power output is stabilized at 75 percent of its initial peak value, as shown in Figure 4. Under similar conditions, approximately 70 percent of CO_2 molecules are dissociated with dc excitation and the laser power output is stabilized at approximately 30 percent of its initial value. Furthermore, it was also discovered by mass spectrometry that a minute amount of water vapor in the laser gas could further reduce the number of dissociated CO_2 molecules during microwave discharge. The laser power output could be stabilized at 80 percent of its initial value.

With a room-temperature catalyst, the initial CO_2 concentration and power output can be recovered after several minutes of operation with both discharge methods. The catalyst is Pt-Rh Al_2O_3 - Pellets (721P, Fa, Degussa). Figure 5 is the result with microwave excitation. The result with dc excitation was shown in reference [10]. The same catalytic converter was used for both types of discharge.

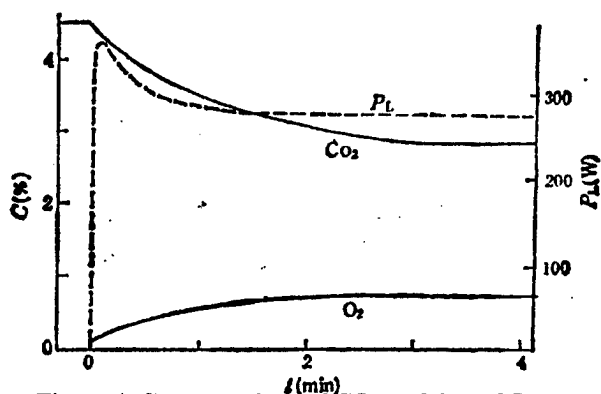
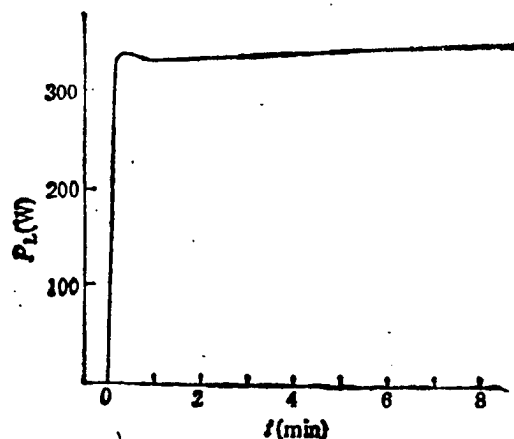
In order to meet the needs of an industrial production line, the laser was operated continuously for 10 hours at

90 percent relative humidity. Despite the high humidity, even with water condensed on components that were cooled, the entire device operated normally. During this period of observation, the maximum instability in laser power output is 1.6 percent. At this kind of high humidity, it is very difficult for dc and rf-excited high-power CO₂ lasers to operate normally.

In this experiment to demonstrate principle, the three discharge units are independent. In principle, it is possible to use more units in series to form CO₂ lasers of various power levels. Thus, it is possible to have a laser power output of the order of several thousands to several tens of thousands of watts. Furthermore, due to varying discharge length and discharge-tube diameter, it is possible to use an optical unstable cavity or stable cavity to obtain the desired laser beam mode. Microwave-excited CO₂ lasers from several kW to 10 kW are being developed.

In this experiment, the entire microwave discharge process was conducted in a metal waveguide or metal discharge cavity. The waveguide and discharge cavity, including the inner and outer case of the magnetron, were grounded. There is no high-voltage hazard. It is safe and reliable and causes no pollution. Just like a microwave oven, it is easy to use and has a long life. It is extremely suitable for a production line.

The authors wish to thank J. Uhlenbusch of Duesseldorf University for his support and J. H. Schaefer for his assistance in the experiment.

References

1. J. Uhlenbusch, Proc. XVI International Conference of Phenomena in Ionized Gas, Univ. Duesseldorf, (1983), 330.
2. E. Beyer et al., LASER OPTOELEKTR., 5(1986), 35.
3. G. Herziger, PROC. INDUSTRIAL APPLICATION OF HIGH-POWER LASER, SPIE, 455(1984), 65.
4. S. Mueller and J. Uhlenbusch, J. PHYS. D: APPL. PHYS., 20(1987), 697.
5. Zhang Zebo, YINGYONG JIGUANG [APPLIED LASER TECHNOLOGY], No 5(1984), 6.
6. W. Schock and H. Huegel, VDI-BERICHT, 25(1986), 535.
7. S. A. Ahmed and R. Kocher, PROC. IEE E, 52 (1964), 1737.
8. J. F. Young, et al., LASER FOCUS, 4(1982), 63.
9. W. Schall, et al., Proc. Gas Flow and Chemical Laser, Bristol, England: Adam Hilger, (1985), 301.
10. S. Mueller, et al., Proc. Gas Flow and Chemical Laser, Bristol, England: Adam Hilger, (1985), 11.

Situation, Development of Laser Industry in China 90FE0275A Shanghai YINGYONG JIGUANG [APPLIED LASER TECHNOLOGY] in Chinese Vol 10 No 3, Jun 90 pp 97-100

[Article by Hu Xiaobao [5170 2699 5508] and Hua Meirong [5478 5019 5554] of Shanghai Institute of Laser Technology: "Present Situation and Development of Laser Technology in China"]

[Text]

I.

Laser technology has become a milestone in the development of science and technology in the twentieth century. It also plays an important role in the development of modern information technology. Laser-related products are receiving a great deal of attention in developed nations.

Laser technology began in the early 60's in China, and has been developed rapidly over the past 30 years. There are over 300 organizations involved in laser research, development, and application in China. More than 10,000 people are working in laser-related areas. One-third of them are experts and technicians, forming a team of considerable strength. Close to 1,000 accomplishments have been achieved in research and development involving lasers. In areas such as length standards, laser fusion, and satellite ranging, China is among the leaders in the world. As for laser materials, China is ahead of the rest of the world in materials such as barium metaborate crystal. A foreign scholar pointed out that "As far as lasers are concerned, from fundamental research to high-power laser development to laser applications, China's strength is considerable."

Based on incomplete statistics, the value of laser-related products from 1981 through 1985 is 230 million yuan. The mean increase over 5 years is 13 percent. During the first 4 years in the Seventh Five-Year Plan the value of laser products is 400 million yuan. However, based on incomplete statistics, we imported more than \$150 million worth of laser elements and devices in the Sixth Five-Year Plan. This fact indicates that despite a high research level and an early start, our laser products could not meet domestic demand in terms of quality, quantity and specification. As a whole, commercialization of laser products is still evolving and developing, albeit on a small scale.

Let us analyze the situation of laser products. Based on the numbers provided by over 100 major laser manufacturers, the values of laser products manufactured between 1980 and 1989 are tabulated as follows:

Year	Value (10,000 yuan)	Growth rate (%)
1980	3,184	—
1981	2,747	-13.7
1982	4,386	59.7
1983	5,290	20.6

Values of Laser Products Manufactured During 1980-1989 (Continued)

Year	Value (10,000 yuan)	Growth rate (%)
1984	4,466	-15.6
1985	5,985	34.0
1986	7,324	22.4
1987	8,922	21.8
1988	11,228	25.8
1989	13,963	24.4

We can see that between 1985-1989, the rate of increase of the value of laser products is much larger than that of industrial products manufactured in China during the same period. The value and growth rate of laser-related products in recent years are reported in the table below.

Category	1985		1986			1987		
	output value	percentage	output value	percentage	annual growth rate (%)	output value	percentage	annual growth rate (%)
	(10,000 yuan)	—	(10,000 yuan)	—	—	(10,000 yuan)	—	—
Military	2,363	39.4	2,387	32.6	1.0	3,104	34.8	30.0
Device, component, material	2,171	36.2	2,336	31.9	7.7	2,810	31.5	20.1
Detection system	703	11.7	788	10.8	12.1	963	10.8	22.2
Medical system	545	9.1	952	13.0	74.7	1,301	14.6	36.7
Machining system	157	2.6	369	5.0	13.5	234	2.6	-36.6
Others	60	1.0	489	6.7	71.5	510	5.7	4.3
Total	5,999	100	7,324	100	22.1	8,922	100	21.8

The table shows that a large percentage belongs to military products and components. The technology is also more mature. Laser machining systems that have a wide range of applications only take up a small percentage (under 5 percent). From the rate of growth, medical laser devices have been developed quite rapidly in recent years. As for high-end laser products that are being rapidly developed abroad, such as the laser printer and CD players, there is nothing to show in China. China's laser industry has the following characteristics:

1. The laser industry is an industry led by science and technology. High-level or quality lasers and laser-based machines are being manufactured by research institutes and universities with development capabilities or by large factories with sufficient resources. These institutions have high quality engineers, plentiful resources, and numerous accomplishments. They often go into small-scale production on their own or work jointly with a business in the field. Technical accomplishments are being converted to products quickly. From the present laser industry structure, domestic laser products primarily come from this kind of institution. They are the

major players of China's laser industry. This is totally dictated by the fact that lasers are a knowledge and technology intensive product. It is similar to the situation during the initial stage in developed nations.

Due to this situation, although the research level is high, products are still being made by hand in the laboratory. Manufacturing technology is quite behind. It is difficult to meet our actual need in terms of either quality or quantity. Therefore, the commercialization of lasers in China is a big step behind other countries. Today, the degree of commercialization of laser-related products is still low in China. The annual production value is near 100 million yuan.

2. In recent years a large percentage, approximately 30-40 percent, has belonged to military products. Next, products of significant value, approximately 30 percent, are lasers. Military products are influenced by the international situation and armament. The output value is not stable. In addition, a high percentage of basic lasers also reflects a lack of development and promotion of applications. Especially, laser thermal treatment has an

extremely low percentage. It requires a great deal of promotion to commercialize such systems.

3. In recent years the laser industry in China has made a great deal of progress. In particular, there are several new programs involving international collaboration or technology import, such as the laser video disk and CD player production line imported by Shenzhen, the He-Ne laser line imported by Beijing, the Ar⁺ laser joint venture in Shanghai, and other items under negotiation such as laser machining and laser printers. It is estimated that the output value will increase dramatically. The level and scale of China's laser industry will also be significantly altered. In addition to military laser products, we have been exporting laser crystals, non-linear crystals, gas lasers, and medical laser equipment in small quantities. This will create a good condition for us to penetrate the international marketplace.

The major problems in the evolution of the laser industry are:

1. The government does not have an overall development plan for the industry. Due to a lack of guidance, the evolution process involves a great deal of initiative and blindness. For example, some laser product lines were imported without a market survey. The product does not meet a need in the domestic market. Furthermore, there is a shortage of interfacing technical people. It ended up that assembled products were stockpiled or production lines could not be put in operation, leading to huge economic losses. As another example, everyone is competing to manufacture medical laser equipment. Low end products are being duplicated. The quality of product is poor. Thus, it is a waste in a grand scale which also directly affects the reputation of this new technology.

2. Lasers are a high tech product. However, it is being manufactured by hand in most production facilities. There is neither advanced manufacturing equipment nor modern management skill. Thus, it is not being industrialized and product quality cannot be rapidly improved. To date, some lasers, such as Ar⁺ laser, have poor life and stability. Technology to manufacture semiconductor laser, which is a high volume product with numerous applications, is lagging behind because of poor quality. These are a few examples of our problems.

3. The level of investment in the laser industry is low. The government has not made any investment in the laser industry. It has made few arrangements in product development. The level of investment made by various local authorities and departments is also extremely low. This is another reason why the laser industry is lagging behind.

II.

The basic approach to developing our laser industry is to take full advantage of our existing potential to import and absorb advanced production technology from abroad in order to actively explore the worldwide laser market.

Aiming at the international market, participating in worldwide competition and using foreign exchange generated by exports to evolve the laser industry in China is our strategy for developing the laser industry in China. In view of our economic level and scale, it is hopeless for us to develop a high tech industry if we do not participate in international competition.

We must take full advantage of certain technological edges and focus on the export of a number of products such as tactical laser weapons, laser crystals and gas lasers. We have to organize the development and production of laser products with a wide range of applications, such as medical laser equipment and laser machining equipment. We must continuously improve the quality of our products and upgrade and expand the product line to rapidly reach certain capacity. We have to strengthen international cooperation and import advanced technology such as production technology for lasers and laser-based information products. We must systematically build a number of research and production bases with modern production facilities and strong technical strength. As we attempt to promote applied laser technology, we must also emphasize the development of new applications and new technology, and pay attention to basic research in laser technology.

The goal is to develop a laser industry essentially to meet domestic needs in 5-7 years. In addition, it will have a certain scale of exports to compete internationally. By the year 2000, the value of output should be comparable to that of the United States in the late 1980s.

Major breakthroughs in laser technology will be made in major areas of the national economy, such as automobile manufacturing, machine building, and electronic products, in the Eighth Five-Year Plan. It will bring significant economic benefits.

In the leading edge of major research in laser technology, we will continue tracking progress made elsewhere and contribute to breakthroughs in some major areas.

The key areas of development for our laser industry are:

1. Basic laser elements, including high power CO₂ laser, Ar⁺ laser, YAG laser, excimer laser, laser crystals and non-linear crystals.

2. Laser machining, including high power CO₂, YAG laser machining systems, excimer laser precision machining system, etc.

3. Medical laser, including various laser-based medical diagnostic and treatment devices.

4. Military laser, including laser ranging, blinding, guidance and tactical simulation systems.

5. Laser detection, including laser alignment, guidance, on-line inspection and non-destructive testing system.

6. Laser information product, including laser printing, CD, LV and document filing systems.

III.

In order to establish the strategic goal of building a laser industry in China, the government has to take certain forceful measures in the leadership system, policy making and financial investment. We recommend the following:

1. Break departmental and regional barriers to develop lateral joint ventures. Research and production units can be organized to jointly manage and develop a specific technology or type of laser. In areas with a good foundation for developing a laser industry, such as Beijing, Tainjin, Shanghai, Nanjin, Xian, Chengdu, Chongqing, and Wuhan, we should take full advantage of existing resources to build industrial entities, as soon as it is mature to do so. Each group plans its own development schedule. They should establish either a loose or tight relationship among themselves based on guidance given from the government.

Each industrial group may integrate research and development, manufacturing, sales and service together. In order to expand the range of applications of lasers, promote laser technology and provide better technical service, each group may establish laser machining and testing service centers, medical laser centers and laser product quality monitoring centers.

The key industry or production facility in the group may be organized in the following way.

(1) Use a technology development oriented research institute as a base to attract manufacturing plants to join in. Thus, it becomes a technology intensive industry. Since low volume, large variety and high quality are the characteristics associated with these high end lasers products, it is appropriate to let a research institute organize their production. In addition, we must create conditions for research institutes with some production capabilities to build modern manufacturing facilities.

(2) A research and production joint venture may be organized by a factory of considerable technical strength with some research institutes. Factories in close or relevant areas may be consolidated into a base to produce laser products. During the formation of these industrial entities, we must make full use of our advantages in laser research at research institutes and higher learning institutions and the possible conversion from military to commercial use.

(3) Technical personnel are encouraged to organize a variety of small special high tech enterprises to develop and produce laser products based on certain accomplishments or patents.

(4) Various forms of international cooperation should be organized to attract foreign enterprises to jointly form high tech laser companies. They will then become the backbone of our laser industry or export bases.

2. Encourage exports. High tech products are very profitable. We should focus on and encourage exporting high tech products. It not only generates foreign exchange for the government but also pushes the quality of our laser products toward international standard and improves

the level of technology development and production in China. We have to select products that are suitable for both domestic and international market, and give priority to build an export base or enterprise for laser products. We have to seek government approval in order to receive various favorable treatments.

3. The government ought to have a comprehensive plan for technical effort, product development and production of laser products. A dedicated unit should be involved to organize and coordinate the industry. Investments should come from a variety of sources. It is going to be a low capital and high output, or ongoing investment with continuous return, or using profit to pay for growth type of investment. Primarily, local government, departmental unit and manufacturers may raise capital through various means and the central government may provide a loan or a grant to fund a portion or a foundation to develop laser technology. Limited capital will be rolled over again and again.

The government must pay attention to the research on production technology and technique related to laser products. The amount of investment in building up production technology ought to be increased. We should import some advanced production technology and equipment for certain critical products in order to strengthen the capability of our laser industry. Furthermore, we have to organize a technical team to absorb and digest such technology in order to convert it for domestic use.

4. Government should provide tax breaks. Laser is an intelligence and technology intensive industry. It should receive the same preferential treatment as microelectronics. Businesses engaged in the development and production of laser products should have their income tax reduced or waived and adjustment tax exempted. In addition, 10 percent of their gross sales may go back to product development and be included in cost.

New products registered with central or city government are exempted from income and adjustment taxes for three years. Fifty percent of the profit may be used for product development and equipment replacement.

All regional and departmental units should include laser development programs into their own "Torch Plan" in order to receive various preferential treatments.

5. Address standardization and metrology related issue and control quality of products. This area is especially important during the initial stage of an industry. In principle, we should adopt international standards to the extent possible. If a laser product has no international standard, a national standard should be formulated jointly by the national standardization department and the relevant research institute in order to ensure the serialization and standardization of laser products to allow similar devices be interchangeable. High volume or critical laser products must have their quality demonstrated. Quality evaluation programs and contests must be held periodically nationwide in order to stimulate improvement in product quality.

**Comparative Study of Photoluminescence of
 $\text{In}_{0.15}\text{Ga}_{0.85}\text{As}/\text{GaAs}$ and $\text{GaAs}/\text{Al}_{0.3}\text{Ga}_{0.7}\text{As}$
Quantum Wells Under Hydrostatic Pressure**

40100005 Beijing *BANDAOTI XUEBAO [CHINESE
JOURNAL OF SEMICONDUCTORS]* in Chinese
Vol 11 No 9, pp 718-723

[English abstract of article by Li Guohua, Zheng
Baozhen, Han Hexiang, and Wang Zhaoping of the
Institute of Semiconductors, CAS, Beijing and Shanghai
Laboratory for Infrared Physics]

[Text] The photoluminescence of $\text{In}_{0.15}\text{Ga}_{0.85}\text{As}/\text{GaAs}$ and $\text{GaAs}/\text{Al}_{0.3}\text{Ga}_{0.7}\text{As}$ quantum wells (QWs) grown on the same substrate have been studied comparatively at 77K under hydrostatic pressure up to 60 kbar. Both the transitions from the conduction subband to heavy- and light-hole subbands in the $\text{GaAs}/\text{Al}_{0.3}\text{Ga}_{0.7}\text{As}$ QW were observed. But only the transitions to heavy-hole subband were observed in the $\text{In}_{0.15}\text{Ga}_{0.85}\text{As}/\text{GaAs}$ QWs. The pressure coefficients of the photoluminescence peaks of $\text{In}_{0.15}\text{Ga}_{0.85}\text{As}/\text{GaAs}$ QW increase with the decrease of well width in contrast with the results in $\text{GaAs}/\text{Al}_{0.3}\text{Ga}_{0.7}\text{As}$ QW. Several peaks associated with the indirect transitions were observed at a pressure higher than 48 kbar. This is discussed briefly.

Further Report on Fiber-Optic Cable for Domestic Communications

Spectral Symbols, Standard Cable Structures

91FE0024a Beijing DIANXIN JISHU
[TELECOMMUNICATIONS TECHNOLOGY]
in Chinese No 8, Aug 90 pp 19-21

[Article by Xing Jiexiang [6717 1367 6272]: "Spectral Identification Symbols for Optical Fibers and Common Optical Cable Structures". For earlier report on this topic, see JPRS-CST-90-027, 29 Oct 90, pp 22-23]

[Text] This paper introduces the spectral identification symbols (color codes) for optical fibers in domestically manufactured optical cables, as well as the structures of common optical cables.

I. Color Codes for Optical Fibers

Based on Chinese National Standard GB7424-87, all optical-fiber units, fibers in each unit, conductor units (pairs) and insulating cores must be identified by a full spectrum or pilot spectrum of colors. Specifically, the color arrangement and location are defined in the product standard by the manufacturer. As for the color code, it may be in full color, or in stripes or rings in single or multiple colors. The color code should be bright and obvious. It must not fade within the temperature range of installation and operation and must not come off and get on other elements in the optical cable.

Similar to an electrical cable, regardless whether an optical cable is identified by a full or pilot spectrum of colors, it has end A and end B. Table 1 shows the color sequence of a cable with eight loosely jacketed optical fibers. If one follows this arrangement in a clockwise manner, it is end A as shown in Figure 1. If it is counterclockwise, it is end B. The optical cable manufactured by the Houma Cable Plant of the Ministry of Posts and Telecommunications (MPT) has the optical fiber close to the red signal wire labeled as 1 and other fibers are 2, 3, 4, ... in a clockwise sequence. This arrangement is end A. Otherwise, it is end B.

Table 1.

optical fiber	1	2	3	4	5	6	7	8
jacket color	blue	yellow	green	red	orange	white	blue	red

II. Structures and Dimensions of Some Optical Cables Manufactured in China

The structures and dimensions of some optical cables manufactured by the Houma Cable Plant are shown in Table 2 and Figures 2-12. Figure 2 is a cross-section of a cable with two loosely jacketed fibers; 1 and 2 are optical fibers, red and white are signal wires and the other two are filler wires. Figure 3 is a cross-section of a cable with four tightly jacketed fibers; 1-4 are tightly jacketed fibers, the red and white wires opposite to each other are signal wires, and the other three white wires and a green wire are filler wires. Figure 4 is a cross-section of a cable with four loosely jacketed fibers; 1-4 are optical fibers and the red and white wires are signal wires, while the other two are fillers. Figure 5 shows the cross-section of a supported cable with six tightly jacketed fibers; 1-6 are optical fibers, the red wire and the opposite white wire are signal wires, and the other three white wires and 1 green wire are fillers. Figure 6 is a cross-section of a cable with six tightly jacketed fibers; 1-6 are optical fibers and the blue and the red are signal wires. Figure 7 is a cross-section of a cable with six loosely jacketed fibers; 1-6 are optical fibers and the blue and the red are signal wires. Figure 8 is a cross-section of a cable with eight tightly jacketed fibers; 1-8 are optical fibers and the green and the red are signal wires. Figure 9 is a cross-section of a cable with 12 tightly jacketed fibers; 1-12 are optical fibers and the white and the red are signal wires. Figure 10 is a cross-section of an optical cable with 12 tightly jacketed fibers; units G₁ and G₂ contain six optical fibers each, S₁-S₅ contain four copper wires each, and T green is a filler wire. Figure 11 is a cross-section of a cable with 24 tightly jacketed fibers; G₁-G₄ contain six optical fibers each, the red and the white are signal wires, and the other two wires are fillers. Figure 12 is a cross-section of an optical cable with 24 loosely jacketed fibers; G₁-G₄ contain six optical fibers each; the red and the white are signal wires, and the other two are fillers.

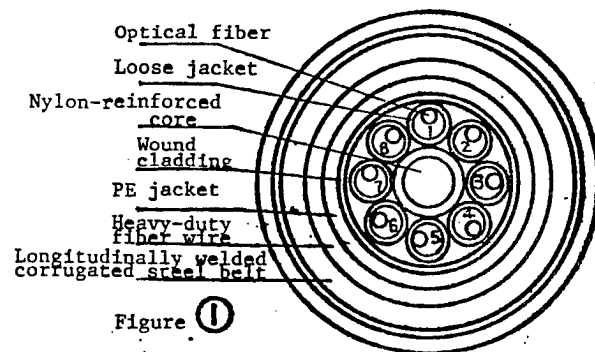
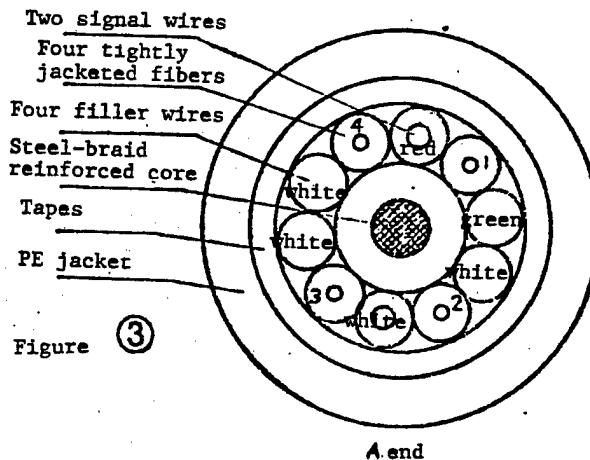
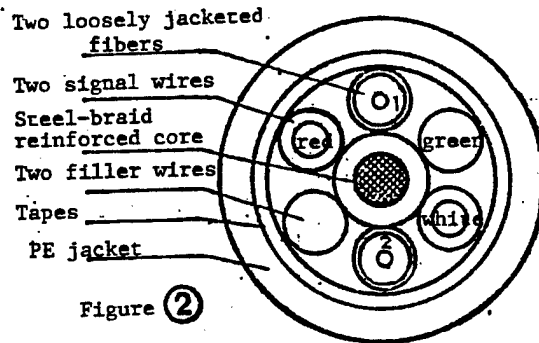

Figure 1

Table 2

Specification Dimensions(mm) Structure	Figure no.	2 fibers		4 fibers		6 fibers		8 fibers		12 fibers		24 fibers	
		Loose jacket	Tight jacket	Loose jacket	Tight jacket	Supported tight jacket	Loose jacket	Tight jacket	Tight jacket	Tight jacket assembly	Tight jacket assembly	Loose jacket assembly	
		Figure 2	Figure 3	Figure 4	Figure 5	Figure 6	Figure 7	Figure 8	Figure 9	Figure 10	Figure 11	Figure 12	
Optical fiber	Plastic jacket OD	1.40	0.85	1.40	0.85	0.85	1.40	0.85	0.85	0.85	0.85	0.85	1.40
	Assembly OD	---	---	---	---	---	---	---	---	4.30	---	4.00	4.30
Signal wire	Copper wire diam	0.50	0.50	0.50	0.50	0.50	0.50	0.50	0.50	---	---	0.50	0.50
	Signal wire diam	1.40	0.85	1.40	0.85	1.40	1.40	0.85	0.85	---	---	0.85	1.40
Reinforced core for optical fiber	Steel braid spac	---	---	---	---	---	---	---	---	Steel wire	0.34 x 7	0.34 x 7	---
	Steel braid OD	---	---	---	---	---	---	---	---	0.95	1.00	1.00	---
Reinforced core for optical cable	Steel braid spac	0.34 x 7	0.34 x 7	0.34 x 7	0.34 x 7	0.67 x 7	0.34 x 7	0.67 x 7	0.67 x 7	1.50 x 7	1.20 x 7	1.20 x 7	---
	Steel braid OD	1.00	1.00	1.00	1.00	2.00	1.00	2.00	2.00	4.50	3.60	3.60	---
	Extruded PE OD	1.45	2.10	2.10	1.45	3.00	2.10	2.75	3.40	7.10	4.00	4.30	---
Star-shaped assembly	Copper wire diam	---	---	---	---	---	---	---	---	0.90	---	---	---
	Extruded plastic	---	---	---	---	---	---	---	---	1.75	---	---	---
	Star shape OD	---	---	---	---	---	---	---	---	4.30	---	---	---
Filler wire	PE string diam	1.40	0.85	1.40	---	1.40	1.40	0.85	---	Pipe 4.30	Pipe 4.00	Pipe 4.30	---
	Braid OD	4.30	3.80	4.80	3.20	5.80	4.80	4.60	5.10	15.70	12.00	12.90	---
Cable core	Tape specs	13 x 0.04 polyester tape, 20 x 0.1 glass fiber tape, 20 x 0.18 non-woven tape											
	Tape OD	4.60	4.60	4.20	5.30	3.60	6.20	5.30	5.50	18.10	12.40	13.00	---
Jacket	Al-plastic OD	---	---	---	---	---	---	---	---	6.20	Al pipe 18.50	13.10	14.00
	PE jacket OD	8.00	7.60	8.70	7.90	9.00	8.30	8.30	9.60	With 1st layer 81	10.50	17.40	---
Weight (kg/km)		58	60	67	56	90	71	84	89	845	477	533	---

Note: manufactured by the House Cable Plant of NPT



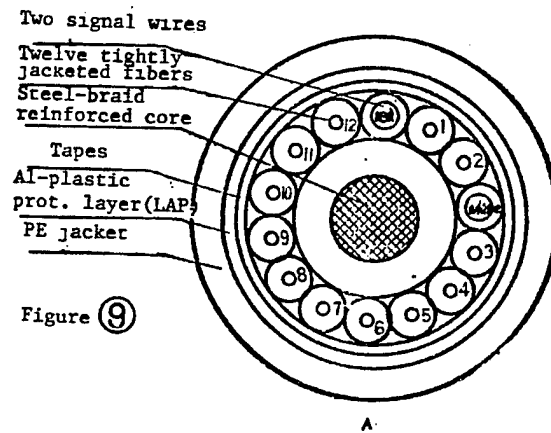
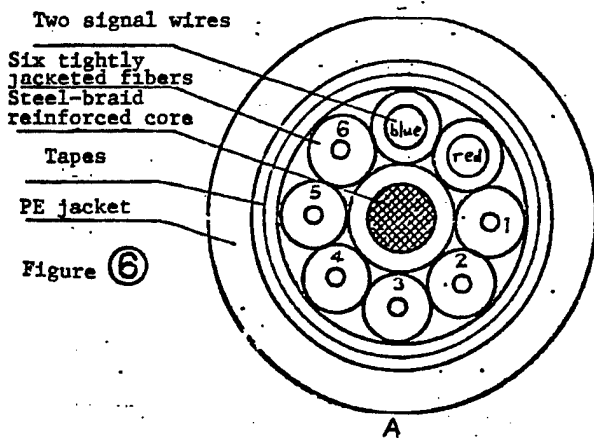
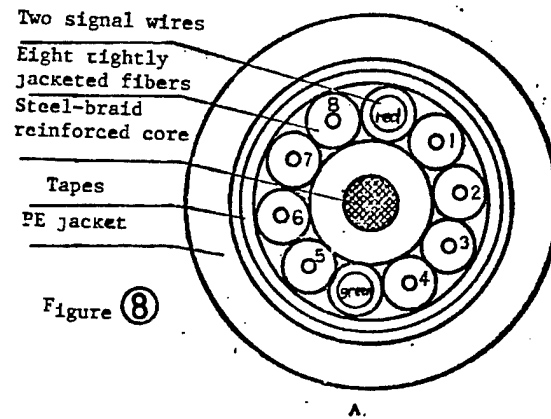
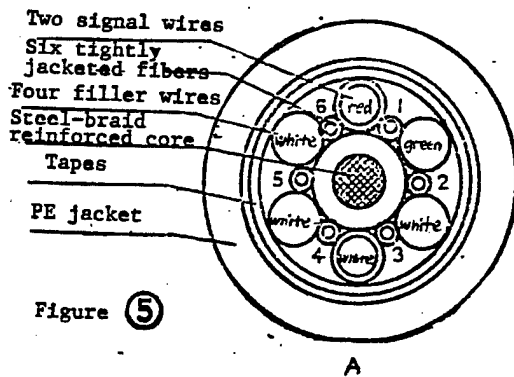
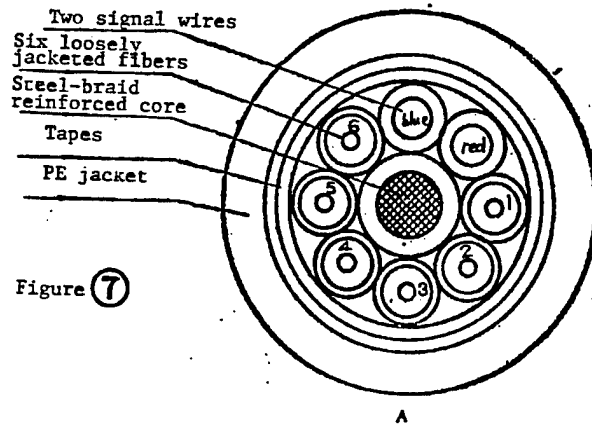
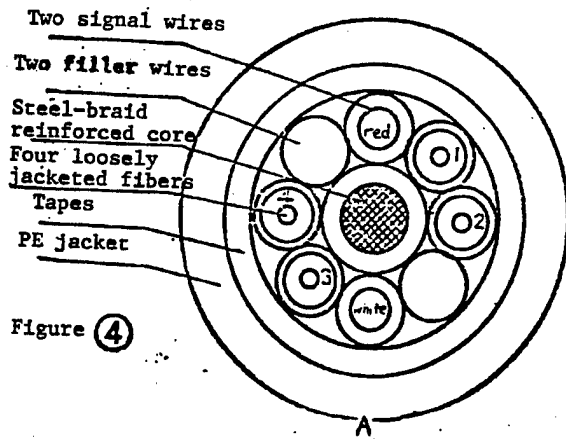

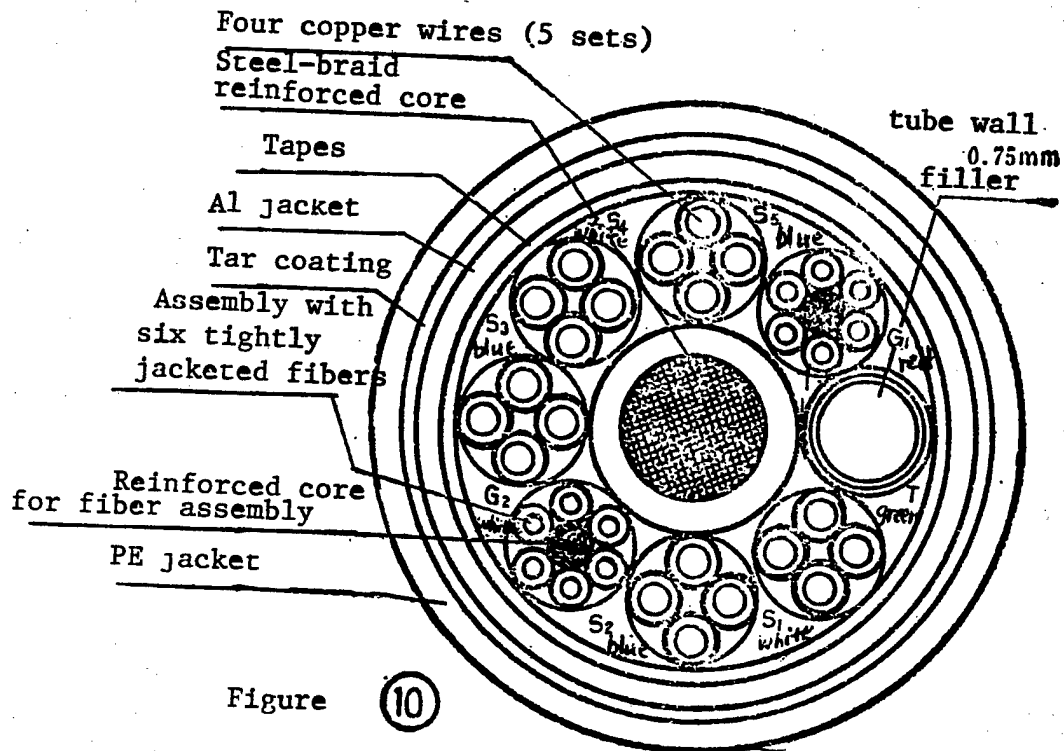

Figure

10

A

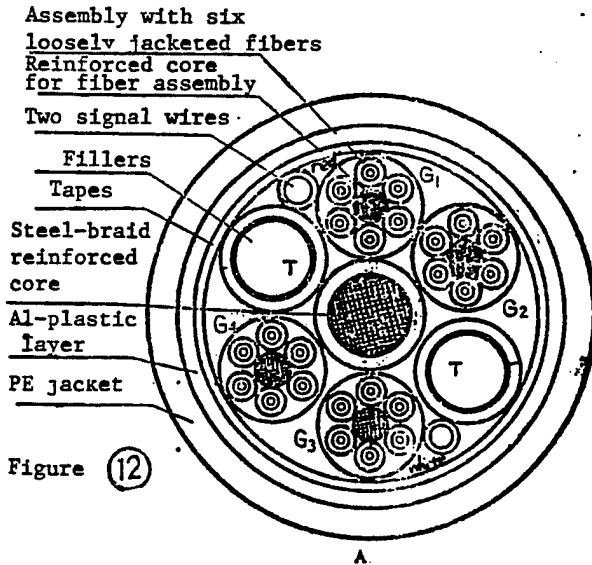
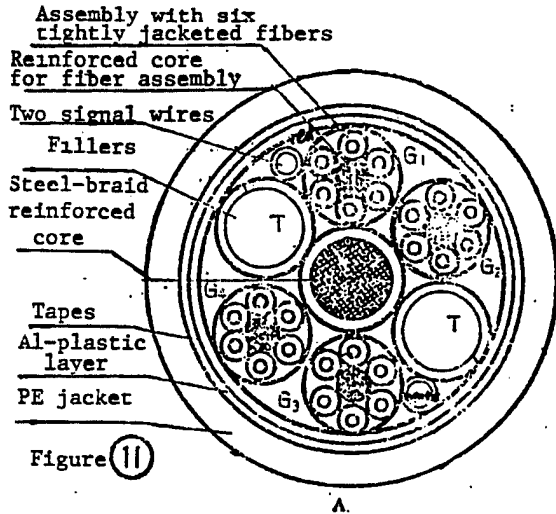

Recommendations on Optical Parameters

91FE0024b Beijing DIANXIN JISHU
[TELECOMMUNICATIONS TECHNOLOGY]
in Chinese No 9, Sep 90 pp 42-43

[Article by Xing Jian [6717 0256]: "Recommendations and Regulations on Optical Cable Parameters"]

[Text]

I. CCITT G.651, G.652 and G.653 Recommendations

During 1985-1988, in order to adapt to the rapid progress in fiber-optic communications, CCITT (Consultative Committee on International Telephony and Telegraphy) perfected recommendation G.651 (regarding characteristics of cables with 50/125 μm multimode graded-index fibers), essentially completed recommendation G.652 (regarding characteristics of single-mode optical-fiber cables) and proposed recommendations G.653 (concerning characteristics of cables with dispersion-shifted single-mode optical-fibers) and G.654 (concerning characteristics of cables with 1.55 μm minimum attenuation single-mode optical fibers). G.654 is still to be further perfected. The highlights of recommendations G.651, G.652 and G.653 are summarized in Table 1.

II. Specifications Concerning Fiber-Optic Cables in Chinese National Standards

The Chinese National Bureau of Standards issued 43 standards concerning fiber-optic cables in 1987. During the process of formulating these standards, all CCITT standards that met the situation in China have been adopted. All issued standards were published in volumes 1 and 2 of "Introduction to National Standards on Posts and Telecommunications" in 1990. These standards have been published by China Standards Publishing House and People's Posts and Telecommunications Publishing House. Technical requirements of these standards are extracted and shown in Tables 2-6. Table 2 shows the geometric and optical characteristics of single-mode and multimode optical fibers. Table 3 shows the transmission characteristics and classification of single-mode optical fibers. Mechanical characteristics and classification of single-mode optical fibers are shown in Table 4. Temperature characteristics and classification of single-mode optical fibers are shown in Table 5. Table 6 shows the overall dispersion coefficients of multimode graded-index and single-mode optical fibers.

Table 1

Recommendations Parameter	G. 051 (1984)	G. 652 (1988 rev.)	G. 653 (1988)	
Fiber type	Multimode	Single-mode	Dispersion-shifted single-mode	
Optimal operating wavelength	near 850nm near 1300nm	1300nm	1550nm	
Fiber geometry	Core (mode field) diameter	50µm ± 8%	9~10µm ± 10%	7.0~8.3µm ± 10%
	Cladding diameter	125µm ± 2.4%	125µm ± 2.4% (± 3µm)	125µm ± 2.4% (± 3µm)
	Core concentricity error	< 6%	≤ 1µm	≤ 1µm
	Core non-circularity	< 6%	(No need for recommendation)	(Easily achieved; no need for recommendation.)
	Cladding non-circularity	< 2%	< 2%	< 2%
Cut-off wavelength	-	2m coated fiber, λ _c = 1100~1280nm 20 cable+2m fiber, λ _c < 1270nm	(To be investigated)	
Attenuation coefficient	850nm { I < 4dB/km II < 3.5dB/km III < 3dB/km	Minimum values: 0.3~0.4dB/km (1300nm) 0.15~0.25dB/km (1550nm)	< 0.5dB/km (1550nm) < 1dB/km (1300nm)	
	1300nm { I < 3dB/km II < 2dB/km III < 1.5dB/km IV < 1.0dB/km V < 0.8dB/km			
Dispersion coefficient	850nm ≤ 120PS/km·nm	at 1285~1330nm, 3.5PS/km·nm	at 1525~1575nm, 3.5PS/km·nm, 1300nm to be determined	
	1300nm ≤ 6PS/km·nm	at 1270~1340nm, 6PS/km·nm		
Dispersion coefficient	-	at 1550nm, 20PS/km·nm	-	
Numerical aperture	0.18~0.24	-	-	
Maximum dispersion at relay station	-	140Mb/s.sys., 300PS/nm 4×140Mb/s.sys., 120PS/nm	-	

Table 2

Item	Multimode graded-index fiber	Single-mode fiber (GB7424-87)	B ₁ -type single-mode fiber (GB9771-88)
Cut-off wavelength			1100~1280nm
Core diameter (Mode field diam.)	50 ± 0.0% μm	(9-10) ± 10% μm	(9-10) ± 10% μm
Cladding diameter	125 ± 2.4% μm	125 ± 3 μm	125 ± 3 μm
Core (mode field) non-circularity	< 0.6 %		< 0.6 %
Cladding non-circularity	< 2 %	< 2%	< 2 %
Core (mode field)/cladding non-circularity	< 0.6 %	< 0.5~3.0 μm	≤ 1 μm
Maximum theoretical numerical aperture	(0.20~0.22) ± 0.02		

Table 3

Class		A	B	C	D
Attenuation factor, not greater than (dB/km)	1300nm	0.35	0.50	0.70	0.90
	1500nm	0.25	0.30	0.40	0.50
Total dispersion coefficient not greater than (PS/nm·km)	1285~1330nm	3.5	3.5	3.5	3.5
	1270~1340nm	6	6	6	6
	1550nm	20	20	20	20

Table 4

class	A	B	C
Screening tension [Sustained time (s) not less than (N)]	10	5	4

Note: mechanical strength screening was done after fiber was pulled.

Table 5

Wavelength (nm)	Total dispersion index not greater than (PS/km·nm)	
	Multimode graded-index fiber	Single-mode fiber
850	120	
1300	6	

Table 5

Class		A	B	C
Additional attenuation at (1300nm) ≤ (dB/km)	-40°~+40°C	0.0	0.1	0.2
	-30°~+50°C	0.0	0.1	0.2
	-20°~+60°C	0.0	0.1	0.2
	-5°~+60°C	0.0	0.1	0.2

Note: temperature cycling experiment done after plastic jacket was mounted.

Civil Construction Completed at Chengdu Earth Station

90P60072B Beijing DIANXIN JISHU
[TELECOMMUNICATIONS TECHNOLOGY]
in Chinese No 8, Aug 90 p 48

[Untitled brief note by Jiang Zhai [36082298]]

[Text] The main civil construction for the Chengdu Satellite Earth Station has basically been completed. This station, one of the large regional central stations of the present domestic system, will be linked into the network consisting of other domestic earth stations and international circuits with outlets in China. Completion of the station will expand the capacity of the outlet circuits for Sichuan Province and areas of the Southwest, as well as enhance capabilities for TV transmission, data communications, and FAX transmission, and thus be of great significance for the economic construction of Sichuan and the Southwest.

Experimental Study of Photomixing with 1.3-Micron Graded-Index-Rod External-Cavity Semiconductor Laser for Coherent Fiber-Optic System

90FE0177A Beijing TONGXIN XUEBAO [JOURNAL OF CHINA INSTITUTE OF COMMUNICATIONS]
in Chinese Vol 11 No 2, Mar 90 pp 60-63 [MS received 10 Nov 88]

[Article by Zhang Jianping [1728 1696 1627], Hui Rongqing [1920 2837 1987], and Guan Gejian [1351 0344 0313], doctoral candidates at Beijing University of Posts and Telecommunications; Wu Yizun [0702 1744 1415], professor at Beijing University of Posts and Telecommunications; and Ye Peida [0673 1014 1129] professor at Beijing University of Posts and Telecommunications and member of the Chinese Academy of Sciences: "Experimental Study of Beat with 1.3-Micron Graded-Index-Rod External-Cavity Semiconductor Lasers"]

[Text] Abstract

This paper reports the beat and coherent transmission experiments with 1.3- μm InGaAsP short graded-index-rod external-cavity semiconductor lasers. Relatively stable beat patterns have been obtained at several wavelength points. A curve showing the single longitudinal mode (SLM) linewidth of the grade-index-rod external-cavity laser versus the injection current was measured using a beat method. Furthermore, a coherent FSK [frequency shift keying] modulation/demodulation experiment with a 100 MHz sinusoidal wave was performed. It was found that this type of laser could be used in coherent fiber-optic communications systems with FSK modulation.

I. Introduction

In 1962, it was demonstrated at Bell Labs with a gas laser and lens waveguide system that the reception of heterodyne and homodyne light could improve the signal to noise ratio of the system compared to direct detection with intensity modulation.¹ Since 1980, research on coherent fiber-optic communications systems has been very active worldwide.² A coherent fiber-optic transmission system not only has higher reception sensitivity compared to a direct modulation/demodulation transmission system, but also provides an opportunity to fully utilize the low dispersion window of the optical fiber to narrow down the frequency spacing for multiplexing. It has bright prospects in long-distance trunk lines and local networks.

A beat experiment is a fundamental test for coherent fiber-optic transmission. It plays a significant role in the study of the spectral characteristics, frequency stability and modulation properties of lasers that are used as a signal source or a local oscillator. Because of its excellent dynamic single-mode behavior, the graded-index-rod external-cavity semiconductor laser is used in high-speed direct modulation systems.³ However, it has not been used in a coherent fiber-optic system. This paper reports the use of 1.3- μm -wavelength InGaAsP short graded-index-rod external-cavity semiconductor lasers in a beat experiment as a preliminary work on coherent fiber-optic transmission. The second section introduces the experimental apparatus and the third section provides results.

II. Experimental System

The output of ordinary semiconductor lasers has multiple longitudinal modes in free operation. One of the authors used a graded-index-rod as an optical feedback element to construct a SLM tunable semiconductor laser.^{4,5}

In this work, a 1.3- μm InGaAsP short graded-index-rod external-cavity semiconductor laser was used as the light source. Figure 1 shows a schematic diagram of the graded-index-rod external-cavity laser. We employed an integrated structure to solidify all components on the same piece of heat sink. Thus, it is structurally simple and compact and has a minimal environmental effect. Thus, it may become a practical device. The graded-index-rod is composed of an ordinary multi-mode optical fiber. The fiber was first fixed in a capillary and then sliced, ground and polished to make it slightly less than $\frac{1}{4}$ wavelength long, approximately 180 μm . Finally, one end of the graded-index-rod was gold-plated to form a reflective mirror and the other end was coated with a film to increase transmission. The specific theory associated with mode selection and frequency fine-tuning is discussed in reference [5].

Figure 2 shows the laser spectrum in free operation with a monochromator. Figures 3(a) and 3(b) are spectra obtained with a monochromator and a scanning interferometer, respectively, after adding the graded-index

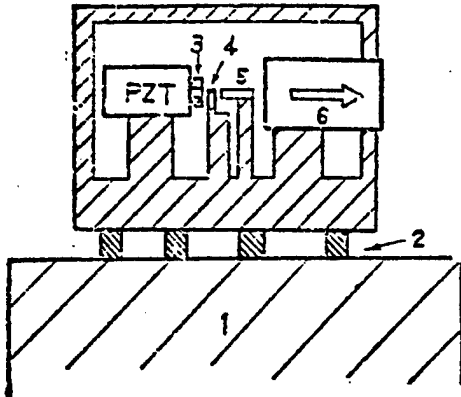

Figure 1. Schematic Diagram of the Graded-Index-Rod Semiconductor Laser

Key: 1. Heat sink 2. Semiconductor cooler 3. Graded-index rod 4. Laser chip 5. Graded-index lens 6. Optoisolator [PZT—piezoelectric transducer]

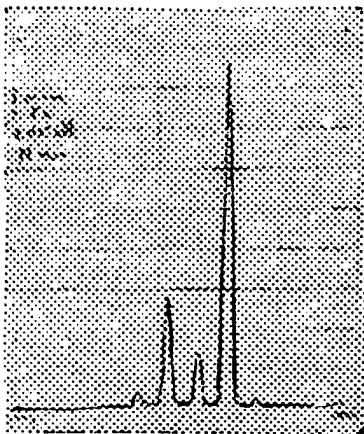

Figure 2. Spectrum of Semiconductor Laser in Free Operation

rod. The side-mode suppression ratio is greater than 35 dB, which would completely meet the requirements for the beat experiment and for coherent transmission.

As we know, if two light beams have frequencies ω_1 and ω_2 and linewidths $\Delta\nu_1$ and $\delta\nu_2$, then a beat signal with frequency $\omega = |\omega_1 - \omega_2|$ and linewidth $\Delta\nu = \Delta\nu_1 + \Delta\nu_2$ can be obtained after frequency mixing. Figure 4 shows the block diagram for the beat experiment. The light beams from the two semiconductor lasers LD₁ and LD₂ are sent to the two input ends of the fiber-optic directional coupler. One of the output ends is used for monitoring. The other end is used for frequency mixing and amplification by an optoelectronic converter. A spectral analyzer was used to observe the beat signal. Fluctuations in temperature and injection current have a tremendous impact on the semiconductor laser. We employed a constant temperature and constant current system. The

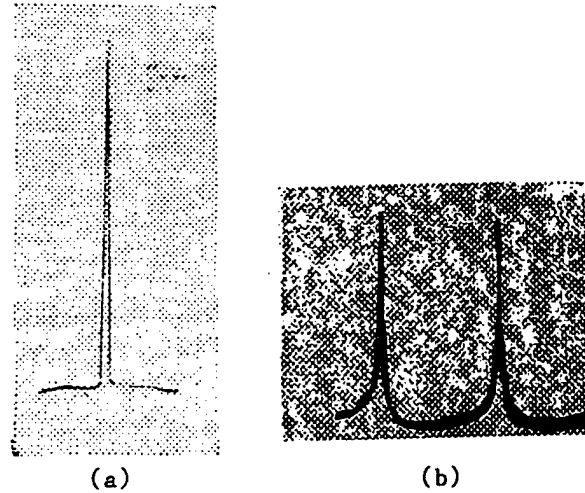

Figure 3. Spectra With Graded-Index-Rod External Cavity

Key: a. From Monochromator—b. From Scanning Interferometer

accuracy of temperature control is better than 0.05°C and the variation of injection current is less than 2 μ A. An optoisolator was placed between the output surface of the laser and the input end of the optical fiber. The degree of isolation is greater than 30 dB, in order to minimize the effect of reflection from the far end of the fiber on the semiconductor laser. By controlling the length of the coupling cavity and the operating temperature of the laser, it is possible to adjust the resonance wavelength of the semiconductor laser over a wide range.⁵ The resonance frequency can be fine-tuned by changing the injection current.

III. Experimental Results

Despite the fact that the two lasers were operating independently, because measures to ensure constant temperature and constant current were taken, especially due to the steady mode-selection effect of the graded-index-rod external cavity, relatively stable beat signals were obtained. Figure 5 shows the beat spectrum taken by the spectral analyzer.

Because of the tunability of the graded-index-rod external-cavity semiconductor laser, it is possible to tune the beat, which provides the basis for multi-channel transmission. In this system, steady beat signals were obtained at four wavelength points 12 Angstroms apart between 12974 Angstroms and 13010 Angstroms. At each wavelength point, the beat signal is continuously tunable between 0 and 1.5 GHz (limited by the bandwidth of the mixing amplifier).

In communications, different modulation schemes have different linewidth requirements for the light source.⁶ More important, linewidth of light source is one of the

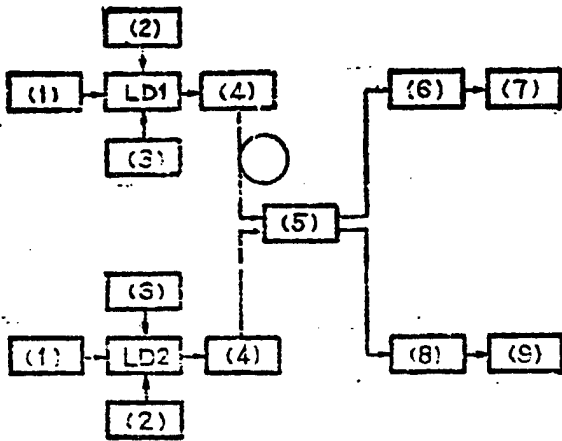

Figure 4. Block Diagram of Beat Experiment

Key: LD1 and LD2 are two graded-index-rod external-cavity semiconductor lasers. 1. External cavity controller 2. Constant current source 3. Constant temperature system 4. Optoisolator 5. Optical-fiber directional coupler 6. Monitor 7. Power meter 8. Optoelectronic converter 9. Spectral frequency analyzer

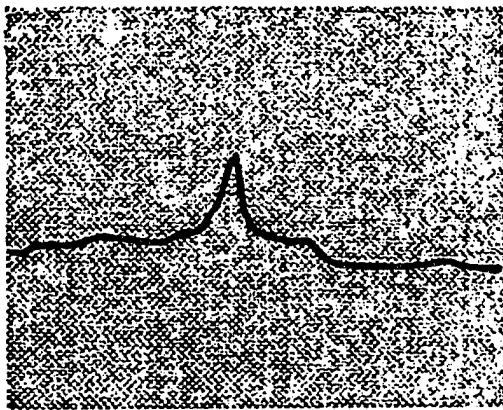

Figure 5. Beat Signal Observed on a Spectral Analyzer

important parameters affecting the quality of coherent optical-fiber transmission. There are many ways to measure spectral linewidth, such as monochromator, scanning interferometer and the automatic heterodyne method. The first two methods are often inaccurate because they are limited by the resolution of the instruments. The last one requires longer fiber and additional components such as an acoustic-optical modulator.⁷ It is relatively complicated and is an indirect measurement. The measured linewidth is dependent on the length of the optical fiber⁹ and is not accurate enough. The linewidth of the beat signal is the superposition of the linewidths of the two lasers. Therefore, it is simple, direct and accurate to measure the linewidth of the beat under certain conditions (i.e., the resonance frequencies of the two lasers are close). Figure 6 shows the measured

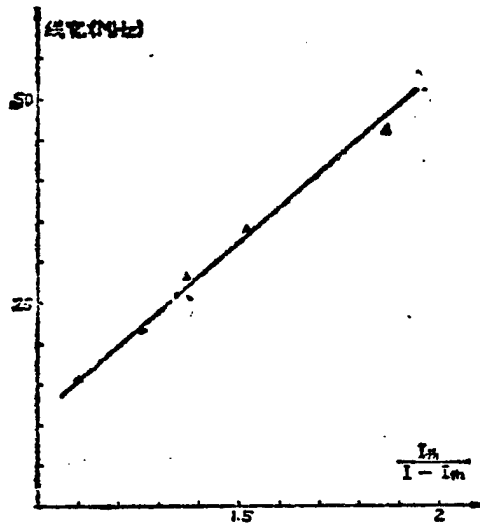

Figure 6. Line Width of #10 Laser vs. Injection Current Obtained by the Beat Method, threshold current $I_{th} = 3$ mA.

SLM linewidth of a graded-index-rod external-cavity semiconductor laser as a function of injection current. It is in agreement with the modified Schawlow-Townes law. In order to overcome the effect on the accuracy due to difference in laser power output, it is necessary to control the injection currents to limit the difference in power output.

N. K. Dutta, et al., observed the effect of external light feedback on a graded-index-rod external-cavity semiconductor laser.⁸ However, because of the limited resolution of their instrumentation, they did not see the long external cavity mode caused by light feedback. In this work, we conducted a more detailed study. When the optical fiber was directly coupled to the laser and the length of the fiber was 3 m (the length in the fiber directional coupler), several beats approximately 33 MHz apart were observed on the spectral analyzer. This was caused by the optical-fiber external-cavity mode due to the reflection from the far end of the fiber. Figure 7 (b) shows the beat signal with 100 m of optical fiber. Due to small mode spacing and large noise, the beat appeared to have a very broad spectral linewidth. In reality, it is an envelope of beats from many optical-fiber external-cavity modes. Figure 7 (a) is the beat of a 3-m-long fiber with partial elimination of light feedback. The three beats caused by the optical-fiber cavity could still be seen. The spacing is still 33 MHz. This experiment indicates that although weak light feedback from the far end of the fiber would not cause large-scale mode skipping, this laser, just like any other semiconductor laser, would operate in multiple long external cavity modes using the fiber as the external cavity.

On the basis of this beat experiment, a preliminary coherent optical-fiber transmission experiment was performed. Figure 8 shows a block diagram of the experiment. It employed the FSK direct modulation, single-filter wave-detection scheme. The modulation rate was

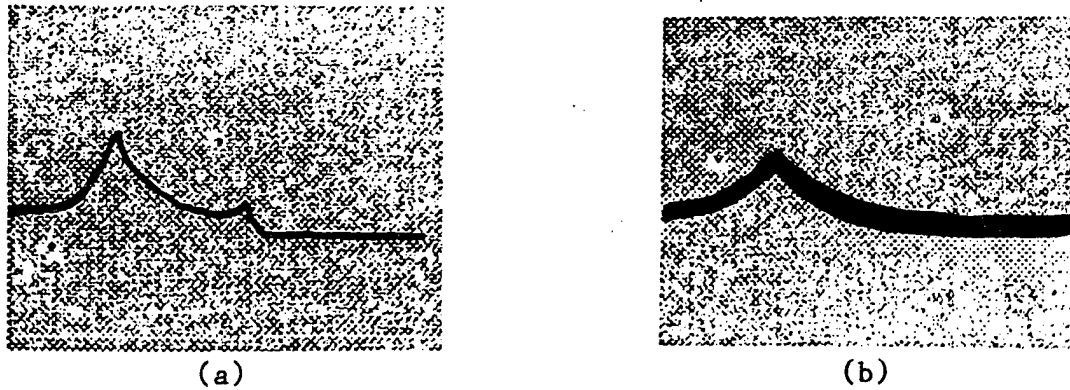

Figure 7. Effect of Light Feedback From Far End of Optical Fiber

Key: (a) Incomplete Light Elimination—(b) Beat with 100-m-Long Fiber

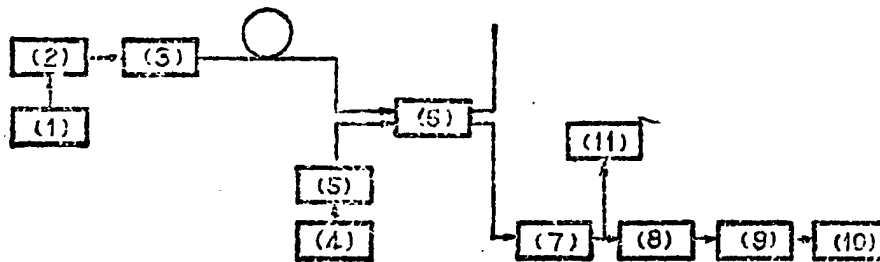

Figure 8. Block Diagram of the Coherent Optical-Fiber Transmission System

Key: 1. Modulation signal source 2. Laser signal source 3, 5. Optoisolators 4. Local oscillator laser 6. Optical-fiber directional coupler, 7. Optoelectronic converter 8. Envelope detector 9. Low-pass filter 10. Oscilloscope 11. Spectral analyzer

100 MHz. Figure 9 [photograph not reproduced] shows the modulated-demodulated signal. The upper curve is the demodulated wave form. Due to the mismatch of the demodulating circuit, the signal to noise ratio is still not sufficiently high. However, this already demonstrated that this type of laser could be used in a coherent optical-fiber communications system.

The graded-index-rod external-cavity semiconductor laser is simple to fabricate, compact in size, easy to select mode and tune, and has excellent single-mode characteristics. To date, this type of laser has not been reported as a part of a coherent transmission system. The results of this beat experiment and preliminary coherent optical-fiber transmission experiment show that it might become a better coherent optical-fiber transmission system after additional frequency-stabilizing measures are taken and matching circuits are developed.

The authors wish to thank Laboratory No. 7 of the CAS Institute of Semiconductors for providing the lasers, and Ma Xiaoming [7456 0879 2494] for fabricating the 1.3- μ m optoisolators.

References

1. H. A. Haus and C. H. Townes, Comments on Noise in Photoelectric Mixing, *Proc. IRE.*, Vol 50, No 6, pp 1544-1546, June, 1962.
2. T. Kimura, Coherent Optical Fiber Transmission, *IEEE J. Lightwave Tech.*, Vol LT-5, No 4, pp 414-428, April, 1987.
3. K-Y, Lion, et al., Single-Longitudinal-Mode Stabilized Graded-Index-Rod External Coupled-Cavity Laser, *Appl. Phys. Lett.*, Vol 45, No 7, pp 729-731, 1984.
4. Zhang Jianping and Tao Shangping [7118 1424 1627], "1.3 μ m Single-Frequency Semiconductor Laser with Graded-Index-Rod External Cavity," *Proc. Sino-Japanese Joint Meeting on Optical Fiber Science and Electromagnetic Theory*, Nanjing, China, May 1987.
5. Zhang Jianping and Tao Shangping, "Graded-Index Rod External-Cavity Single-Frequency Semiconductor Lasers," *ZHONGGUO JIGUANG [CHINESE JOURNAL OF LASERS]*, No 11, 1988.

6. L. G. Kazovsky, Coherent Optical Receivers: Performance Analysis and Laser Linewidth Requirements, International Technical Symposium SPIE-85, San Diego, CA, Aug 1985.

7. T. Okoshi, K. Kikuchi and A. Nakayama, Novel Method for High-Resolution Measurement of Laser Output Spectrum, Electron. Lett. Vol 16, pp 630-631, 1980.

8. N. K. Dutta, et al., Effect of External Optical Feedback on Spectral Properties of External Cavity Semiconductor Lasers, Electron. Lett., Vol 20, No 4, pp 588-589, 1984.

9. K. Kikuchi, Impact of 1/f-type FM Noise on Coherent Optical Communications, Electron. Lett., Vol 23, No 17, pp 885-887, Aug 1987.

First DMW System for Guangxi Province

90P60072C Beijing DIANXIN JISHU
[TELECOMMUNICATIONS TECHNOLOGY]
in Chinese No 8, Aug 90 p 48

[Untitled brief note by Chen Zhiyong [7115 1807 0515]]

[Text] Guangxi Province's first digital microwave (DMW) system has been completed. This system, running through the autonomous region's [central and]

northeast parts, links Nanning, Liuzhou, and Guilin. There are eight microwave stations along the 355.6-km-long route.

The system utilizes a 6GHz high-end 140Mbit/s DMW system imported from Italy's GTE Company. Channel allocation is 1 + 1, and each channel has a capacity of 1920 telephone lines. All of the system's intermediate stations are unattended.

Reorganization of Satellite Broadcasting Corporation

90P60072A Beijing DIANXIN JISHU
[TELECOMMUNICATIONS TECHNOLOGY]
in Chinese No 8, Aug 90 p 47

[Untitled, unsigned brief note]

[Text] The China Communications Broadcast Satellite Corporation was recently set up as a bureau-level enterprise unit directly subordinate to the Ministry of Posts & Telecommunications. The new corporation has been formed from the former China Broadcast Satellite Corporation, a unit directly under the guidance of the State Council and the State Science & Technology Commission. The new corporation's principal responsibilities, under the direction of the State Planning Commission, will be in the construction, business operation, and management of China's communications broadcast satellite system.