

19980519 190

**PROSPECTOR IX:  
HUMAN POWERED SYSTEMS  
TECHNOLOGIES**

November 2-5, 1997

Edited by

M. Frank Rose, Co-Director  
For the Prospector IX Board of Directors

Sponsored by

Space Power Institute  
Auburn University, Alabama 36849  
&  
Army Research Office  
Research Triangle Park, North Carolina 27709-2211

Held at the  
Washington Duke Inn  
Durham, North Carolina

*The views, opinions, and/or findings contained in this report are those of the author(s) and should not be construed as an official Department of the Defense position, policy, or decision, unless so designated by other documentation.*

M. Frank Rose, Director  
Space Power Institute  
Auburn University, Alabama

**DTIC QUALITY INSPECTED 2**



# TABLE OF CONTENTS

<u>Title</u>	<u>Page</u>
<b>Preface</b>	iii
<b>Executive Summary</b>	1
<b>Introduction</b>	11
<b>Working Group Deliberation Summaries</b>	
• Group 1: Applications	15
• Group 2: Technology	29
• Group 3: Research	45
<b>Overview Session 1</b>	
• “Soldier System in 20 Years” (O’Brien)	51
• “Future Requirements for the Dismounted Soldier” (Buser)	65
• “Power for the Dismounted Soldier - A Summary of the NRC Study” (Rose)	79
• “DARPA Perspective on Power Technology” (Nowak)	95
• “Special Operations Perspective” (Raineri)	107
<b>Overview Session 2</b>	
• “SUO Power Profiles - CECOM Perspective” (Stephens)	113
• “NASA Investment in Spacecraft Systems Technology” (Sovie)	131
• “Rudimentary Physics of Man-Powered Systems” (Ballato)	155
• “History and Status of Personal Power Devices for the Commercial Market” (Hutchinson)	201
• “Physiological Factors that may Limit and Techniques that may Enhance Human Performance” (Glickman-Weiss)	211
<b>Technology Session 1</b>	
• “Electrostatic Integrated Force Arrays” (Goodwin-Johansson)	243
• “Energy Conservation and Alternative Energy Sources for Wearable Electronics” (Siewiorek)	257
• “Energy Storage/Conversion Materials” (Zee)	269

<u>Title</u>	<u>Page</u>
• “Electrochemical Capacitors” (Merryman)	283
• “Compact and Lightweight Energy Conversion using Electrostrictive Polymers” (Kornbluh)	313
• “Lunar/Mars Space Suit Requirements” (Wagner)	331
<b>Technology Session 2</b>	
• “Integrated Power Management for Microsystems” (Fry)	347
• “Seiko Human Powered Quartz Watch” (Seiko - Epson Staff)	359
Overview (Saka)	
Details of the Device (Masuzawa)	
Applications of AGS (Masuzawa)	
• “Overview of Developments in South Africa” (Rijkheer)	385
• “Technological Challenges for Human Powered Systems” (Tkaczyk)	387
<b>List of Attendees</b>	417

## PREFACE

The concept for a series of highly focused workshops dealing with key issues associated with the science and technology of advanced power systems had its origin in many conversations with outstanding technologists all over the world. It became apparent that the difference between the state-of-the-art and what these technologists saw for future needs was so large that new approaches to meet these needs was mandatory. There are a host of key issues which fall into this category such as prime power, thermal management, advanced energy conversion, life support, automated systems and advanced diagnostic techniques just to name a few. Due to the interdisciplinary nature of power systems, any new and successful approach will likely come from a group with diverse backgrounds rather than those schooled in the classic approaches.

Power systems offer unique challenges to engineers and application specialists. While a capability or mission may be feasible, more often than not, the power technology available determines the total mission profile. As the mission profile expands, the demands on the power technology associated with the mission quickly extend beyond the state-of-the-art. For many advanced concepts, power technology is totally enabling. It is not just the "long pole in the tent", it is the "tent". For example, a soldier's rucksack weight for an average mission weighs approximately 115-140 lbs. This weight is approximately 50% batteries and charging devices, which can inhibit the soldier's mobility. Therefore, improvements are needed to provide the frontline soldier with lighter-weight power and recharging capability since he has no source of AC power near the frontline for recharging operations. Often promising concepts are abandoned due to the lack of a foreseeable power technology which could remove it from being a laboratory curiosity. It is insufficient to think totally in terms of system energy density or power density. Due to environmental and safety concerns, the power technologist may be forced to employ non-optimum power systems which drastically limit the performance envelope. Further, the use of exotic materials, exotic fuels, and complexity, reliability etc. further impede the transition from laboratory curiosity to field workhorse. Recalling that "energy and mass are neither created nor destroyed but simply changed from one form to another", energy carried within the system, stored in the chemical bond or in the nucleus, must eventually be used as intended or ejected from the system in the form of "low grade heat". Three options exist for managing waste energy. Having changed its thermodynamic state when useful work was done with it, the excess energy can either be radiated away to space, stored, or convected/conducted into a flowing coolant stream. Each of these techniques has its advantages and disadvantages, almost always adding to the system mass. Clearly, there is a set of tradeoff parameters which must be manipulated to provide an optimum system for a given mission and it goes without saying that it is impossible to achieve the optimum in all parameters simultaneously.

At the request of The Army Research Office, a workshop dealing with Human Powered Systems technology was organized and held at the Washington Duke Inn & Golf Club. This workshop, Prospector IX, is the ninth in the series. All have dealt with power technology and are interrelated to this workshop. The following is a list of the Prospector Workshops and individual focus:

- Prospector I, Thermal Management of Space Based Assets,
- Prospector II, Radioisotope Power Systems,
- Prospector III, High Energy Density, High Power Density Power Sources R&D,
- Prospector IV, Small Engines and Their Applicability to the Soldier Systems,
- Prospector V, Microelectromechanical Systems; Their Applicability to the Soldier System,

- Prospector VI, Electric Actuation,
- Prospector VII, Small Fuel Cells for Portable Power,
- Prospector VIII, Thermophotovoltaics, An Update on DoD, Academic, and Commercial Research, and
- Prospector IX, Human Powered Systems Technologies.

In addition to the above Prospector series of workshops, The Army Research Office sponsored a workshop entitled "Mobile Battlefield Power Workshop," which was conducted in the same format as the Prospector series. All of these workshops produced technical documents which clearly identify key issues which must be addressed to advance the art and all have potential Army applications.

The focus of Prospector IX is to assess whether or not Human Powered Systems are capable of meeting some of the electrical energy needs of the Dismounted Soldier in the field. The requirements placed on power technology by the "Soldier System" concept are as demanding as that of any spacecraft and shares many common requirements such as extreme reliability, safety, minimum weight and volume and, of course, the ever increasing demands placed due to environmental concerns.

There is always something in a name. Just as the prospectors of old sometimes worked the tailings of old diggings searching for a missed nugget, we too reviewed the current techniques "looking for nuggets", before embarking on a search of new ground. For this we assembled a wide range of technologists--engineers, physicists, physiologists, manufacturing specialists, and managers representing the government laboratories, industry and the university community. The groups were charged with evaluating Human Powered Systems technologies which might be relevant to the Dismounted Soldier .

In keeping with the tradition of the previous Prospectors, the workshop was patterned after the highly successful Gordon Conferences which have formal morning and evening sessions, leaving the afternoon free for recreation, small group discussions or laboratory tours at the participants' discretion.

The workshop was directed by a group of senior scientists from the Army Research Office, DARPA, CECOM, and The Space Power Institute at Auburn University. The broad technical base represented by the Board of Directors resulted in a unique agenda which covered many of the technologies relevant to Human Powered Systems. The Board members are Dr. Donna Cookmeyer, and Dr. Richard Paur from the Army Research Office, Ms. Mary Hendrickson, from CECOM, Dr. Robert Nowak from DARPA, and Dr. Henry Brandhorst and Dr. Frank Rose from the Auburn University Space Power Institute.

The workshop organizers would like to express thanks to the administrative staff of the Washington Duke Inn & Golf Club, Durham, NC, and to the Administrative Staff of the Space Power Institute for organizing and managing the workshop. Special thanks are due to Ms. Gail Edwards and Ms. Mickie Jacob whose efforts contributed greatly to the success of the workshop and to this archival record.

The pages that follow contain a detailed record of the workshop procedures, an Executive Summary, the results and recommendations of the working groups, copies of the individual technical presentations and a list of the attendees. The attendees were key technologists from government, industry and academia. We appreciate their willingness to give their time and technical skills for this meeting and sincerely hope that this document represents an accurate

distillation of the workshop deliberations. It is, after all, their collective opinion which is archived here and whatever impact this document has in the future is due to their deliberations.

We hope to see many of you at Prospector X.

M. Frank Rose, Director  
For the Board of Directors



## EXECUTIVE SUMMARY

With the evolutionary advances in commercial communication electronics, power consumption of these devices has been reduced to around the 1 to 5-Watt level using power management techniques and low power electronics. At this power level, the feasibility of harvesting energy from the human body to power man-worn electronics is conceptually possible. It appears possible through the use of sophisticated energy management and through low power electronics to reduce the demand for energy by the Dismounted Soldier to a level where it is instructive to examine the potential for the Soldier to produce enough electrical power to provide a substantial amount of the electrical energy needed for a mission. In order to do this, it will be necessary to convert to electricity some of the energy expended by the Soldier during everyday actions.

The human body stores an enormous amount of energy. The energy available from a donut is equivalent to **347 Whr**. The average persons body is approximately 15% fat and represents a stored energy greater than **11,000 Whr**. The average person consumes between **2000 Kcal** and **3000 Kcal per day**, which is, in more familiar units, approximately **2200 Whr** and **3300 Whr**. Since it can take 30 minutes to consume the food with the above energy content, the "charge rate" is about 7 kW for the higher caloric intake. Clearly the amount of energy consumed by an individual is sufficient to provide energy for electronic devices if a suitable method can be found to convert a **small fraction** of that energy to electricity.

The idea of taking some of the energy normally associated with the activities of the human body and converting it to electricity to power external devices is novel, but not new, and has enormous potential if it can be done with modest efficiency and in an unobtrusive manner. This technology is unique and has significant promise for the development of portable power sources for the Dismounted Soldier. Consequently, a workshop on Human Powered Systems was held at the Washington Duke Inn & Golf Club, on November 2-5, 1997, sponsored by the Army Research Office.

To accomplish the objectives of the workshop, a group of scientists, active in technologies relevant to the field, from government laboratories, industry and academia were invited to lecture on a wide range of topics. The technical program consisted of plenary and state-of-the-art sessions covering as wide a range of relevant topics as the allotted time permitted.

With respect to the military, this field is new and innovative but there have been applications of human power to electrical/mechanical systems for decades. Indeed, the hand-cranked portable generator currently employed by special forces falls into this category. It is possible to generate up to 100 watts in this fashion. Devices of this type are not passive and their use effectively immobilizes the individual while power is being generated. The noise generated when operating this device, often make the use of this mechanism unfeasible due to requirements of covert activities. The weight and size of these hand-cranks makes portability less attractive in frontline mission scenarios. A second example is the small "flashlight" which is energized by squeezing a lever. For purely mechanical conversion, the Apollo astronauts took with them to the moon a rotary shaver which employed a small flywheel energy store activated by pulling a cord. Commercially, there is a wind-up radio available from Baygen, and a night vision/starlight scope, manufactured in Russia and available from the Edge Company. Except for the items cited above, there does not appear to be any concerted research effort aimed at exploiting in any way, for military purposes, the energy associated with body motion and how to convert that energy to electricity.

Recent advances in the technologies relevant to harvesting human power, as presented at the workshop, suggest that unobtrusive systems might be built in the range from microwatts to a few watts. As the Army becomes more mobile, a premium is to be paid for capability, reliability, autonomy and minimal mass systems. The frontline soldier, more often than not, does not have access to energy for recharging his power sources and therefore, must carry all his required power sources to complete his mission. The ability to harvest human energy, if favorable in terms of reliability, size, weight, and energy efficiency might translate immediately into increased autonomy time, increased capability, reduce or eliminate certain logistics items, and, perhaps, reduced cost. Fieldable technology rarely equals laboratory prototype or theoretical capability. Obstacles sometimes are fundamental and perhaps can be finessed through appropriate R&D, innovative techniques, and skillful engineering. This workshop attempted to explore some of the possibilities. As confirmed by the plenary speakers and the working groups, there are a number of potential applications where harvesting of human energy could be applied. Typical are:

- Personal battery chargers
- Medical sensors
- Display power sources
- Gun sight power
- Rangefinder

This subject is certainly multi-disciplinary. For example, appropriate electrical converters must be combined with mechanical converters, which in turn must couple to the human body. Further, the need for non-interfering operation is paramount for acceptance. The ultimate utility of harvested energy may not reside in the fundamentals of the techniques used to harvest but in such issues as: can it be manufactured in mass from affordable materials; can it be made robust enough and provide the reliability needed to function in a hostile environment, can it be engineered into a package with minimal signature, can it be made non-interfering with the soldiers normal functioning, and will it provide an enhanced capability to the Soldier in the field.

As the workshop progressed, several pacing ideas emerged which were used to guide the workshop process. These are:

- There is a growing civil market for human powered systems with several products already available on the open market;
- It is only necessary to convert a small portion of the energy consumed as food by the soldier to power some applications.
- There does not appear to be any "fundamental physical reasons" why Human Powered Systems cannot be built with modest efficiencies;
- There is a definite lack of engineering experience with Human Powered Systems of the type of interest to the Military;
- A concerted program could produce laboratory devices for evaluation within 3-5 years.
- There are a large number of relevant disciplines such as MEMS, etc. which should have impact as the field emerges.
- However the energy is harvested, it must not interfere significantly with the normal activities of the soldier and must not impede his mobility.

Assessment of the State-of-the-Art of Human Powered Systems by Characterizing Techniques and Determining Their Applicability to ARMY/DARPA/Civil Applications

The amount of power associated with physical activity was estimated by the Workshop participants. The table below lists some estimates for the power levels associated with physical activity typical of that for the Dismounted Soldier.

<u>Activity</u>	<u>Power in Watts</u>
Sleeping	81
Standing at ease	128
Walking	163
Brisk Walk	407
Long distance running	1048
Sprinting	1630

The Workshop considered several potential sources of energy associated with the human body which might be utilized for conversion to electricity. The most promising are shown in tabular form below.

<u>Source</u>	<u>Est. Max. Power available Watts</u>	<u>Maximum estimated Conversion efficiency</u>
Body heat	116	~3% assuming total capture
Breath	1.0	40% based on turbine eff.
Blood pressure	0.9	about 2%
Upper limb motion	24-60	a few percent
Walking (heel strike)	67	PZT converter ~7%
		Generator ~50%
Body waste (urine)	1-5	Fuel cell ~ 50%

From the above, limb motion and the heel strike associated with walking and running are attractive potential sources of energy as long as the requirements are for levels of a few watts or less. The conversion mechanism will determine the level of power available for a given scheme. Since physical activity is inherently intermittent, it is necessary to have a storage mechanism. Rechargeable batteries, electrochemical capacitors, pneumatics, springs, and flywheels are candidates. Rechargeable batteries and electrochemical capacitors are the most promising with batteries offering higher specific energy and capacitors offering higher specific power. The energy density using spring metals is on the order of 0.4-1.0 joules/gram, making them an attractive candidate. Conversion to electricity still requires a generator of some sort. Numerous candidate mechanisms for harvesting heel strike and limb motion were discussed, however, the state-of-the-art is not advanced enough to determine their efficiency or ultimate utility. **Human powered shavers, radios, flashlights, watches, and night vision scopes are currently available on the civil market. All convert human motion to electricity to power the respective devices.**

Referring to the table above, the energy available from the human is in several forms. The workshop participants examined a representative sample of possible conversion mechanisms in order to analyze the advantages, disadvantages, and appropriate uses for each. The participants chose not to concentrate on conversion mechanisms for thermal energy due to the distributed nature of the heat source and its "low quality." The technologies examined in some depth were electrostrictive polymers, piezoelectric devices, electrostatic force arrays (also called integrated force arrays), inertial energy scavenging combined with a generator and storage element, fuel cells (based on use of urine), and electromagnetic generators.

## Converter Mechanisms

**Electrostrictive polymers:** These materials were compared to piezoelectrics, although they function by harnessing the energy created when mechanical strain is applied to the material after dipole induction with a high voltage charge. They are more flexible than the piezoelectric polymer PVDF, and are capable of producing more energy (reasonable estimates suggest about 1-3 Watts). However, a large voltage (1000V) must be applied to the polymer to get electrical energy out when mechanically stressed. A battery and an appropriate high voltage power supply must accompany any system design. The large voltages inherent in this approach to conversion also creates the requirement for power conditioning from approximately 1000V down to 10V (output), possibly creating an undesirable EM signature in the conversion process. The energy from Electrostrictive polymers comes from a very large change in area (approx. 200%) and a large strain to the material (approx. 100%). Such deformation may impact the durability of the material, as well as affecting the surrounding device. The use of this material for harvesting power has not yet been demonstrated, i.e. no prototype device of this nature has been built or tested.

**Piezoelectric devices:** Piezoelectric materials generate electrical energy from mechanical strain, like Electrostrictive polymers, but do not require the application of a high voltage since they possess a permanent dipole moment. Piezoceramics were not considered, in detail, because of their fragility and the need for a hard strike to generate mechanical strain. The polymeric piezoelectric material PVDF is more promising, but lacks the elasticity of electrostrictive polymers, making it difficult to generate the amount of mechanical strain needed to produce a significant amount of power. Conservative estimates suggest that with current technology, piezoelectric devices would only be useful for low power applications, in the 10-20mW range. However, the requirement for power conditioning is much less than for electrostrictive polymers (from 100V down to 10V) and there is no need for a battery to provide a bias voltage. PVDF is also a well characterized material and prototype devices have been created.

**Electrostatic force arrays:** (Also called Integrated Force Arrays) This technology is in the very early stages of development and relies on mechanical strain and voltage biasing much like the electrostrictive polymers. It has the advantage of being able to be sized for a particular application, using MEMs technology for mW power demands and mesostructure design for power demands in the range of watts. Cost is an issue and the manufacturing process is still under development. There are also issues of durability. The use of this material for harvesting power has not yet been demonstrated, i.e. no prototype device of this nature has been built or tested.

**Inertial energy scavenging:** This technique was based on the paradigm of the "Seiko watch mechanism", using displacement of a proof mass to drive a small generator. The electrical energy produced is stored in a small battery or capacitor which consequently drives the watch mechanism. The level of energy that can be obtained from this approach by conservative estimates is in the mW range, but there is no proof of concept for devices that deliver more than a few microwatts. However, the design and engineering of such a system is further along than the systems based on the converters described above. In the microwatt range, this technique is well characterized and commercial products are available.

**Urine-based fuel cell:** A fuel cell based on the hydrolysis of urine to generate urea is, in principle, possible. The individual elements of the converter system, such as enzymatic hydrolysis of urea to carbon dioxide and ammonia, and oxidation of ammonia to nitrogen and water, have been demonstrated, but no working prototype for the whole fuel cell yet exists. One problem with the system is the need for alkaline conditions that may require transport of sodium hydroxide, a hazardous compound. Also, to achieve power generation in the range of 0.5 - 1W, a system to concentrate the breakdown products of urea, such as reverse osmosis, will be necessary. One attractive feature of this fuel cell concept is the production of water as a by-product of the system.

**Electromagnetic generator:** Two different systems were discussed within the workshop context, with different types of energy input - i.e. using conventional gear trains and using a hydraulic or pneumatic system. In both cases, however, the goal is to generate power in the range of 3W, taking advantage of our large muscular groups (such as in the legs) and simple motions against gravity. There is a wealth of material and applications for small DC permanent magnet motors. These units can be "run backwards" to produce a small generator. Typically these generators are less than 80% efficient while larger devices, designed as generators, are greater than 90% efficient. There is little or no efforts within the scientific community to design efficient small generators of the type needed for harvesting of human energy. Several commercial products are available which utilize these small generators in a human powered mode.

While intriguing, the state of the art for conversion mechanisms is such that it is impossible to estimate military system performance in units such as W/kg.

Within the numerous organizations interested in Human Powered Systems, there is a wide range of individual components whose principles have been demonstrated on the laboratory scale that would appear to be ready for rapid maturity if the applications are real. Examples of intermediate storage units include flywheels, springs, electrochemical capacitors, phase change materials, and shape memory alloys. To date, a few of these components have been assembled into laboratory systems which indicate feasibility and provide marketable products. The most prominent examples which can be purchased are the Seiko electric watch and the "wind-up radio" from Baygen. Numerous examples of storage mechanisms were discussed within the workshop, the most promising are discussed below.

### **Energy Storage Technologies**

**High Rate Rechargeable Batteries.** The state of the art in high rate rechargeable batteries was discussed at "Power '97." In general, very thin lead acid cells can have specific power levels on the order of 10 kW/kg in sizes comparable to "D" cells. The Lithium technologies can provide specific power levels in excess of 1 kW/kg if specially designed. The trade off for high specific power in batteries is decreased specific energy and much reduced life. At the high rates, the useful specific energy is diminished by factors of 3-5 over that for normal operation. Typical specific energy for rechargeable batteries is between 40 and 100 Whr/kg, with the larger number being associated with large cells and normal discharge rates. Appropriate batteries for use in harvesting and storing at modest rates exist in a multitude of sizes ranging from button cells to large packs made up of many cells in series/parallel arrays. The technology is mature with numerous suppliers in a multitude of chemistries and sizes. Due to reduced cycle life, high specific power batteries may not be appropriate for harvesting and high specific energy batteries may have to be used in conjunction with other technologies( if power is an issue) in human powered systems.

**Electrochemical Capacitors.** High rate electrochemical capacitors are just now emerging from the laboratories. In general, devices based on aqueous electrolytes can have specific power in excess of 15 kW/kg with excellent scaling to small sizes. Specific energy is usually factors of 5-10 less than batteries but comparable to "high rate" batteries. The best specific energies for electrochemical capacitors are in the range of 5-15 Whr/kg, with the higher number being laboratory prototypes. Cycle life in excess of one million has been demonstrated in several embodiments. Devices based on hydrous amorphous ruthenium oxide, invented at the Army Research Laboratory, offer the best promise for high specific energy and specific power. The mechanisms and control of leakage currents are not well understood. There are several manufacturers of both prototype and commercial devices which could be used in demonstration systems.

**Springs.** Springs have been used for decades as intermediate energy storage mechanisms. All of these materials store energy due to reversible elastic distortion, with the amount of energy stored proportional to the distortion. In general, the specific energy is on the order of 0.1-0.3 Whr/kg. Note that when the energy stored in a spring is retrieved, it is "mechanical" in form and requires conversion to electrical format. Spring technology is mature and it is doubtful if the specific energy can be increased significantly without compromising life and safety. There are numerous manufacturers who will custom design to specification. Springs form the storage mechanism for the "wind-up" radios from Baygen.

**Inertial/Flywheels.** Flywheels are a well established method of inertial energy storage. In large sizes, flywheels are mature and form an integral part of many advanced systems. The amount of energy stored in a flywheel is proportional to the mass and physical dimensions(moment of inertia) and the angular velocity at which the flywheel is spinning. In modest sizes, energy storage densities approach that of batteries (>50 Whr/kg) but much of the advantages are lost in small sizes due to poor scaling of windage, bearing, and friction effects. Further, flywheels have large gyroscopic effects which tend to interfere with an individuals freedom of motion. The technology is mature and there are numerous manufacturers who will custom design to specifications. Energy is retrieved in mechanical form requiring the use of a mechanical-electrical converter.

**Gravitational.** Storage of energy in the gravitational field of the earth is also a well established art in many forms. Pumped hydroelectric, "pile drivers," and grandfather clocks are classical examples. From the perspective of human energy harvesting, the energy density is proportional to the amount of mass that a human can lift and the distance within the field that he can lift the mass. The work done lifting a 100 kg mass 2 meter against the earth's gravitational field results in 2000 joules being stored in the mass. In mechanical form, this energy can be retrieved with high efficiency making the energy storage density on the order of 20 joules/kg(mechanical), a rather low specific energy. Utilizing the appropriate converter, approximately 1.5 watts could be retrieved for 1000 seconds with each repetitive lifting of the mass. Power is converter specific and higher rates can be achieved for shorter times.

### Identify the Key Research Issues Pacing the Development (or Limiting Full Development) of Efficient, Human Powered Systems

The state-of-the-art is such that useful devices can be built with existing technology. The consensus opinion was that it is feasible to harvest some of the "waste" energy from a soldier, however, that does not answer the question of practicality or desirability. The research and development issues necessary to make these judgments can be divided into those which effect the human in the system, the materials technologies of the converter/storage technologies, their operating environmental response, and those which influence the manufacturing/packaging technologies. The research issues associated with the human in the system are:

- What source on the human do we tap into
- How do we tap into the source unobtrusively
- What is the effect on the human performance as a result of harvesting
- What are the human metrics to be employed in evaluating harvesting
  - Physiological factors
  - Psychological factors
  - Body morphology
  - Field experience by soldiers

- Missions/work profiles

Numerous converter technologies were discussed within the workshop. The most promising have numerous research issues associated with their development to the point of optimum performance. Research issues associated with the most promising converter candidates are:

### **Mechanical to Electrical - Generators**

- There is an enormous "impedance" mismatch for miniature generators. Generators operate efficiently at high rpm but the human input is orders of magnitude slower necessitating high gear ratios or unique hydraulic systems.
- For geared systems, loss mechanisms get worse as the systems become smaller.
- For generators, the design rules and physics are well known but not widely applied to small systems. State of the art for small motors is mature. Technology is relevant but not totally transferable.
- New magnetic materials may impact design rules.

### **Mechanical to Electrical - Piezoelectric and Electrostrictive**

- Optimum coupling coefficients
- Adaptive ensembles of elements
- Compliant electrodes
- New materials
- Fatigue properties/cycle life

### **Thermal to Electrical**

- While there is ample energy, the temperature at which the energy is available is low and consequently the  $\Delta T$  over which thermoelectrics would function is small.
- Energy is distributed over the surface of the human. How do you capture the available energy without disturbing core body functions?
- New thermoelectric materials are needed to have any reasonable hope of utilizing waste thermal energy (DARPA has programs in this area).

### **Chemical to Electrical**

- Biofuel cells not well developed or characterized
- Scaling of composters and digesters and methods of speeding up the processes
- Appropriate catalysts

The research issues associated with storage technologies are:

### **Electrochemical**

- Improved low temperature performance
- Internal loss mechanism understanding and mitigation
- Ruggedization

- Manufacturing technology

### **Inertial**

- Miniature bearings
- New materials
- Miniature gear mechanisms
- Loss mitigation

### **Mechanical/Springs**

- New lightweight spring materials

### **Gravitational**

- Methods for implementing

## **Identify the Major Limiting Factors Which Must Be Addressed as Part of Overall Human Powered System Design**

From the perspective of the Dismounted Soldier potential applications, as described within the workshop working groups, should be scrutinized from the viewpoint of desirability, probability of successful development, and potential impact to the Soldier if successful. From an Army perspective, cost, reliability, maintenance, power capability, energy storage capability, human non-interference, etc., are key issues to any large scale introduction into the inventory. The appropriate technologies are immature for Army applications and as such it is difficult to assess how successful human powered systems will be and how well they will function in the Army environment. All of the equipment for the Dismounted Soldier must be enormously compact and rugged. Consequently, issues such as energy density, power density, minimal signature (both thermal and acoustic), orientation-independence, ruggedization, simplicity of operation, and reliability are the major limiting factors from an operational point of view. Cost is always a limiting factor. These limiting factors translate to the materials issues discussed above as critical research issues. Since human powered systems are just beginning to emerge, there is little data which can be used to judge performance within system configurations. These limiting factors are critical and a data base must be established before any meaningful applications scenarios can be evaluated. The limiting factors are:

- Amount of energy which can be harvested without becoming a load factor for the soldier
- Interference with the normal functioning of the soldier
- Absolute power levels needed for powering the electronic suites
- Reliability in a battlefield environment
- Integration into the soldiers battle dress
- Distribution System

## **Prioritize Research Issues, Indicating the Impact if Research is Successful**

The following are typical of the tasks which could impact human powered electrical systems:

- Efficient lightweight intermediate storage units, optimized to the particular harvesting technology employed
- Analysis of the motion of humans when doing routine tasks and how to couple converters to this motion in an unobtrusive manner
- Laboratory prototypes employing small electromechanical converters and piezoelectric devices
- New converter technologies

Human Powered Devices are at a stage where there are modest commercial successes as witnessed by several products with wide scale availability. The workshop unanimously agreed that the technology exists to allow demonstrations of potential to Army applications. Many of the components necessary to build a significant system have been demonstrated separately. There is sufficient capability in several R&D organizations to build prototypic systems which could be evaluated in the field. Only in that mode can priority R&D issues be identified within the framework of application. Research is needed to accurately characterize the capability of each system concept within the framework of the application to the Dismounted Soldier. The successful application of human powered systems must result in weight savings, cost effectiveness, added capability, and reliability. At the component level, the priorities are:

- Demonstration of a human powered system designed for a specific Army task
- Development of optimized storage and converter technologies, and;
- Integration of the system into the battle dress of the dismounted soldier.

## **Provide Milestones for Research Teams to Attain to Assure Significant Improvements in Human Powered Systems Technology Over a Near-term and Long-term Development Program**

The workshop participants identified several potential applications for the Army. The most promising were:

- Personal battery chargers in the "few watt" category
- Stand alone power for medical sensors, some displays
- Utilizing the appropriate high power intermediate store, high power burst mode communications/data transmission
- Combination exercise/generator devices for the special forces

Given sufficient funding, the technical community should be able to produce prototypic devices for evaluation within three years. An engineering prototype could be built within one year thereafter. The most promising devices appear to be those which would harvest energy from the "heel strike" or utilize gravitational energy in the same mode as the "grandfather clock" for battery charging. For medical sensors, the "Seiko clock" mechanism is ready to apply in the microwatt range.

**Identify Operational/environmental Constraints Such as Materials, Signatures, Manufacturing, and Pollution Which Might Influence Applications or Improvements Envisioned**

Within the framework of the Workshop, the participants identified the following operational constraints due to the peculiar nature of the requirements for the Dismounted Soldier:

- Human powered systems must not have a signature which can be exploited by a hostile force
- Human Powered Systems must be capable of orientation independent operation in many scenarios
- Human Powered Systems must be robust and capable of sustaining mechanical shock typical of that associated with the battlefield environment, and
- Human Powered Systems must offer an operational advantage over current methods of supplying electrical energy to the soldier
- Human Powered Systems must offer minimal interference to the normal operational mode for the soldier

It was the general consensus of the participants that Human Powered Systems shows substantial promise as useful power sources for both civil and military applications. It is not possible to judge the ultimate utility or the degree to which these devices can replace current technology. Clearly as the levels of energy and power needed by the soldier diminish, human powered systems become more feasible, desirable, and perhaps practical.

## INTRODUCTION

Prospector IX is the ninth in a series of workshops dealing directly with advanced technologies applied to the individual soldiers needs. Technology projections for the energy demands for electronic systems relevant to the Dismounted Soldier, as discussed in the NRC report "Energy Efficient Technologies for the Dismounted Soldier," 1998, suggest that some of the energy necessary to power the soldiers electronic suite might be harvested from the individual. As the Army becomes more mobile, a premium is to be paid on autonomy, reliability and minimum mass systems. Improvements in power technology and systems in terms of reliability, cost and maximum energy/power density translate immediately to increased capability and reduced cost. Human Powered Systems could have major impact by providing essentially unlimited autonomy time for the electronic systems in the field. Further it should simplify or eliminate certain items from the logistics chain.

In November, 1990, the first workshop on Mobile Tactical Battlefield Power Technology was held at the request of the Army Research Office. One of the major findings from this workshop was the need for research and development to improve the Army power technology at the low end of the scale. Power technology up to about 500 W and man portable is absolutely key to the effectiveness of the Armies mobility. Further, issues of autonomy time, reliability, scaling and cost were not clearly defined and pointed to the need for other workshops dedicated to subsets of the Armies power needs. The second power workshop on key issues in Electrochemical Power Technology was held at the Auburn University Hotel and Conference Center on May 27 - 28, 1992. That Workshop was requested by the Department of the Army, Assist. Secretary of the Army for Research, Development and Acquisition (ASARDA), and was sponsored by the Army Research Office. The focus for that workshop was the peculiar challenges for power technology associated with the Soldier as a System and the ability of electrochemical power sources to meet the requirements. The enormous energy stored in the nucleus is an attractive source if means can be invented to access this energy in a cost effective and environmentally safe way. To assess this technology, Prospector II studied Radio isotope powered (RTG) systems with emphasis on whether they could meet any of the Army's needs. Since small combustion driven engine-generator systems also appear capable of performance within the requirements for the soldier system, the focus of Prospector IV was on the capability of these small engine-generator systems and the problems which must be solved prior to placing in the inventory. Within the scope of the Soldier as a System, there is a wide range of power requirements depending upon the mission duration and the capability needed for the mission. At Prospector IV, it was pointed out that there was a new and emerging technology of miniature machines or "systems on a chip" which could be applicable to all of the technologies discussed in the Prospector series of workshops and further, might provide new capability. For that reason, Prospector V explored the application of "MIMS" technology to Army needs with special emphasis on the Soldier System. Prospector VII focused on small fuel cells which are even now being evaluated for use in a battlefield environment. If fueled systems are to be introduced into the inventory, it would be desirable to have them function on the current battlefield fuels. Since ThermoPhotoVoltaics (TPV) is emerging and could use battlefield fuels, a workshop, Prospector VIII, was held to assess the potential of TPV and to put its attributes in perspective with respect to competitors such as batteries, fuel cells and small motor-generator sets. If the energy demands for the electronic suite for the Dismounted Soldier decrease substantially, it becomes possible to harvest some or perhaps all of the energy from the waste energy available from the soldier himself. Hence Prospector IX was held to examine the potential of Human Powered Systems. *The goals of the workshop were to draw the participants' attention toward three major sets of criteria -- requirements, key research issues, and projected capabilities and development opportunities.* The specific goals, as determined by the Board of Directors, are to:

- Assess the state-of-the-art of human powered systems;

- Characterize innovative technologies which might be relevant;
- Identify the key research issues pacing the development of efficient human powered systems;
- Identify the key issues which must be addressed as part of overall human powered system;
- Distinguish the limitations imposed by technology from those imposed by nature;
- Establish parameters for the consistent evaluation of human powered sources within an overall system concept for comparison with other technologies;
- Identify the power conditioning technologies appropriate for matching human powered systems to loads within the constraints of cost, weight, and volume;
- Identify the power/energy regimes for which human powered sources are applicable;
- Identify the physiological limits to the human to power systems.

To accomplish these goals, a group of scientists and engineers, active in relevant technologies, were invited to present current perceptions of the state-of-the-art in Human Powered Systems and the relevant technologies. A plenary session was organized to present a government and industrial perspective on needs and possible scenarios which might benefit from human powered devices. The plenary agenda is shown in figure 1.

### **OVERVIEW SESSION - 1**

Chairwoman: Dr. Donna Cookmeyer

- "Soldier System in 20 Years", Robert O'Brien (NATICK)
- "Future Power Requirements for the Dismounted Soldier", Rudolf Buser (CECOM)
- "Power for the Dismounted Soldier - A Summary of the NRC Study", Frank Rose (Auburn)
- "DARPA Perspective on Power Technology", Bob Nowak (DARPA)
- "Special Operations Perspective", Sal Raineri (Special Forces)

### **OVERVIEW SESSION - 2**

Chairman: Dr. Dick Paur

- "SUO Power Profiles - CECOM Perspective", Jim Stephens (CECOM)
- "NASA Investment in Spacecraft Systems Technology", Joe Sovie (NASA LeRC)
- "Rudimentary Physics of Man-Powered Systems", Art Ballato (CECOM)
- "History and Status of Personal Power Devices for the Commercial Market", John Hutchinson (BayGen)
- "Physiological Factors that may Limit and Techniques that may Enhance Human Performance", Ellen Glickman-Weiss (Kent State University)

Figure 1.

As confirmed by the plenary speakers, the interest in novel power technology and its application to the soldier is high and that it appears possible to develop numerous human powered systems both for commercial and military applications.

To accurately determine the utility of human power, it is necessary to attempt to define the state-of-the-art in the relevant technologies. Therefore, to assist in the workshop process, scientists and engineers, active in relevant technologies, were invited to present technology summaries describing the state-of-the-art, near-term-state-of-the-art and give their opinions of ultimate limits with some considerations for practicality. The agenda for the technology sessions is shown in Figure 2.

## TECHNOLOGY SESSION - 1

Chairman: Dr. Bob Nowak

- "Electrostatic Integrated Force Arrays", Scott Goodwin-Johansson
- "Energy Conservation and Alternative Energy Sources for Wearable Electronics", Dan Siewiorek (Carnegie Mellon)
- "Energy Storage/Conversion Materials", Ralph Zee (Auburn)
- "Electrochemical Capacitors", Steve Merryman (Auburn)
- "Compact and Lightweight Energy Conversion using Electrostrictive Polymers", Roy Kornbluh (Stanford Research Institute)
- "Lunar/Mars Space Suit Requirements", Anthony Wagner (NASA/JSC)

## TECHNOLOGY SESSION -2

Chairman: Dr. Steve Merryman

- "Integrated Power Management for Microsystems" Dwayne Fry (ORNL)
- "Seiko Human Powered Quartz Watch" Seiko - Epson Staff
  - Overview Masakatsu Saka
  - Details of the Device Kinya Masuzawa
  - Applications of AGS Kinya Masuzawa
- "Overview of Developments in South Africa" Etienne Rijkheer (Syzygy)
- "Technological Challenges for Human Powered Systems" Eric Tkaczyk (GE)

Figure 2

The remainder of the workshop was spent in small working groups centered around:

- Potential Applications, Specific Mission Needs, State-of-the-Art
- Key Research Issues, Major Limiting Factors, Constraints
- Strategies & Technologies, Priorities, Near & Long-Term Developments, Milestones to Achieve Priorities

In a final session, the working group chairman presented a summary of their group's deliberations and findings to the general assembly of participants. As usual, considerable lively discussion attended each report and was incorporated as accurately as possible in the executive summary results.

The 45 participants were drawn from Industry (15), Academia (10), and Government laboratories/National Laboratories (20) and represented an adequate cross-section of scientists and technologists working, or interested, in the field or in relevant technologies. The remainder of this document is a collection of the workshop presentations and summaries from the working groups.

**WORKING GROUP DELIBERATION  
SUMMARIES**

**WORKING GROUP 1 SUMMARY**

## **Group 1: Applications**

### Members

Henry Brandhorst, Chair

Carolyn Bense

Tom Davies

Tom Dolgaskei

Dwayne Fry

Mary Hendrickson

Jack Kruger

Gerald Lebau

Lionel Levinson

John Munroe

Dick Paur

Sal Raineri

Dan Siewiorek

Ikyo Tokunaga

Kevin Toomey, Recorder

Tony Wagner

## Group 1: Applications

### Charge:

- Assess how the energy will be taken from a human
- What are the converter options?
- Is energy storage necessary?
- Power/energy level achievable - near term and far term
- System Concepts
- What components need to be developed to implement system concept

## Power Sources

<i>Kinematic</i>	<i>Thermal</i>	<i>Chemical</i>
Breathing; 0.4W	Delta Temp.	Waste Products
Arm Motion	Clothing	CO <sub>2</sub>
Leg Motion		Sweat
Hand Motion		Urea
Heart Beating; mW		Digestive Juices
Heel Strike; 4-5W		
Clothing/Equipment;		
Jaw Motion		
Parachute Landing		
Blood Pressure		

## Storage Media

### Batteries

### Capacitors

- super
- ultra
- electrolytic

### Mechanical

springs  
flywheel  
gas pressure  
(gravity/mass)

### Thermal

phase change

### Chemical

fuel cell

electrostatic

magnetic

## Generation (mechanisms)

Brain Energy  
Electromechanical  
    motor generator  
    weight  
Piezoelectric  
Electrostrictive  
IFAs  
Microturbines  
Bimetallics

## Applications

### 21 Day Mission

Face shield Display

Voice activated

IR2/ NVG

Thermal

UV Visual

Magnification 2x

Situation awareness

- maps
- overlays
- mine fields
- photography
  - face recognition
  - machinery

- system performance; weapon status

- medical status; other members

18 month panel came up power estimates for NRC 2015

Frank Rose can get the report; Report is currently being reviewed.

Face Shield Display  $\approx$  2W

Power generator  
hand generator soa= 25J  
rotary pull)

**Classes of Applications Considered**

1 W continuous, 10 W peak (seconds)

2 Watts, 5 hr.

mW continuous

## Types of Power for Applications

Application	Concept	SOA (State of Art)	Issues	Risks
1W, 10W for sec.	Hand Crank Gen (axial gap) Capacitor battery	???	Weight Fatigue Noise	Medium
1 W, 10 W for sec.	IFA Capacitor Battery	218 cm <sup>3</sup> ???	Size Weight Temperature High Voltage range of movement Location	High

2W for 5 hrs	Electrostrictive Battery	0.7w-s/cm <sup>3</sup> 5w-s/step	Power Condition/ conversion Life cycle Strength Shapeability	Medium/Hi
2 W for 5 hrs	Microturbine (shoe)	none est. electrostr.	maybe impractical Space life cycle fatigue	High
2 W for 5 hrs	UREA / FC	???	Eff. → NH <sub>3</sub> membrane bacteria life signature temperature personal hyg.	High

mW continuous	Mech. Gravity battery	Seiko watch	Scalability signature weight Efficiency Battery	High
mW continuous	Thermoelectrics	$zT=1$ eff. <1%	Efficiency MTLS Foot print Body Temp ↓	High

mW continuous	UREA → NH <sub>3</sub> Fuel Cell	NH <sub>3</sub> /Air	Eff. → NH <sub>3</sub> membrane bacteria life signature temperature personal hyg. Residue Duty cycle	High
mW continuous	Electrostrictive Capacitor (Flexible waterproof)	0.7w-s/cm <sup>3</sup> 5w-s/step	Charging Source Strength High Voltage Decay Breathability Abrasion	Medium

mW continuous	"Leg Brace" Electrostrictive Capacitor (Flexible waterproof)	0.7wS/cm <sup>3</sup> 5wS/step	Charging Source Strength High Voltage Decay Breathability Abrasion	Medium

## Overarching Question

**Where is the breakpoint in human energy?**

- Carrying Dead Batteries - vs Generating Power/Energy



**WORKING GROUP 2 SUMMARY**

# Technology Working Group

## *Discussion Summary*

- Piezoelectric harvesters
- Electrostrictive polymers
- Integrated Force arrays
- Inertial scavengers

# Electrostatic Force Arrays

- Conversion Technology
  - $\Delta C$  from deformation alters  $Q/V$ 
    - Like condenser microphone
    - Collect power over mechanical cycle
    - Microstructure
    - No dielectric/electrostrictive material between plates
- Modes: Compressing/Pulling
  - Feet, clothing (limb motion, breathing), Backpack...
- Energy density:  $200 \text{ cm}^3/\text{W}$
- Issues
  - Must bootstrap with battery & condition output voltage
    - MEMS:  $100 \text{ V} \rightarrow 10 \text{ V}$
    - Mesostructure:  $1000\text{V} \rightarrow 10\text{V}$
  - Manufacturing and cost
  - Yield
  - Survivability, durability
  - Not yet demonstrated!

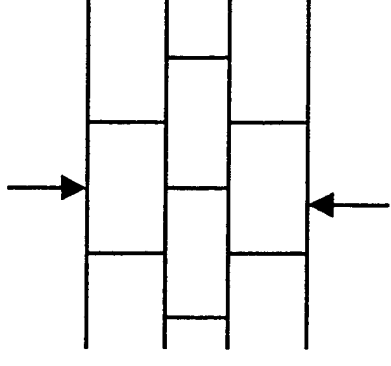

# Electrostrictive Polymers

- Conversion Technology
  - Induced dipoles in electrostrictive material rotate w. strain
    - Collect power over mechanical cycle
  - Aim for 200% change in area, 100% strain
    - 10 cm<sup>3</sup>/W
    - 10-20% Viscoelastic losses
- Modes: Compressing/Pulling
  - Heel/foot strike, clothing (limb motion, breathing), Backpack straps...
- Potential Energy Production: 1-3 Watts
- Issues
  - Geometrical problems with large deformation
    - Materials, electrode surface, implementation, durability
  - No piezo coefficient; need large voltage across plates
    - 1000 Volts discussed in examples
      - Breakdown?
    - Must bootstrap with battery system
  - Large step in power conditioner
    - 1000 Volts raw -> 10 Volts out
    - EM signature in conversion process?
  - Not yet demonstrated!

# Piezoelectrics

- Conversion Technology
  - Force  $\rightarrow$  Piezoelectric charge  $\rightarrow$  Voltage
    - Don't need bootstrap battery
  - Ceramics, crystals impedance mismatched
    - Prefer hard strike, fragile
  - PVDF foil applicable
- Modes: Pulling (exploit 3-1 mode)
  - Feet, Backpack straps(?)
- Energy: 20 mW
  - 4-ply laminate of 90 micron 25 cm<sup>2</sup> sheets, 2% strain, circa 1 Hz
  - Calculated by Toda @ AMP for shoe insert
  - Estimates range 10-100 mW/cm<sup>3</sup>
- Issues
  - Low Power capacity
    - Difficult to pull multilayer foil at high strain
    - Trickle-charge, low-SS power applications
  - Interferes very little with sole, foot motion
  - Little/no mechanics, proven materials
  - Power conditioning: 100 V - 10V
  - Ongoing work by AMP and MIT; prototype soon
  - HyperElastic piezo polymer (FE Xtals in LC matrix)??

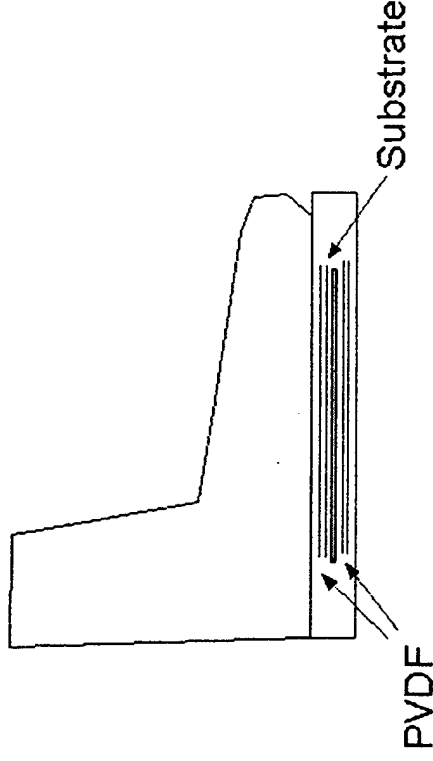

# PAN Touch Communication

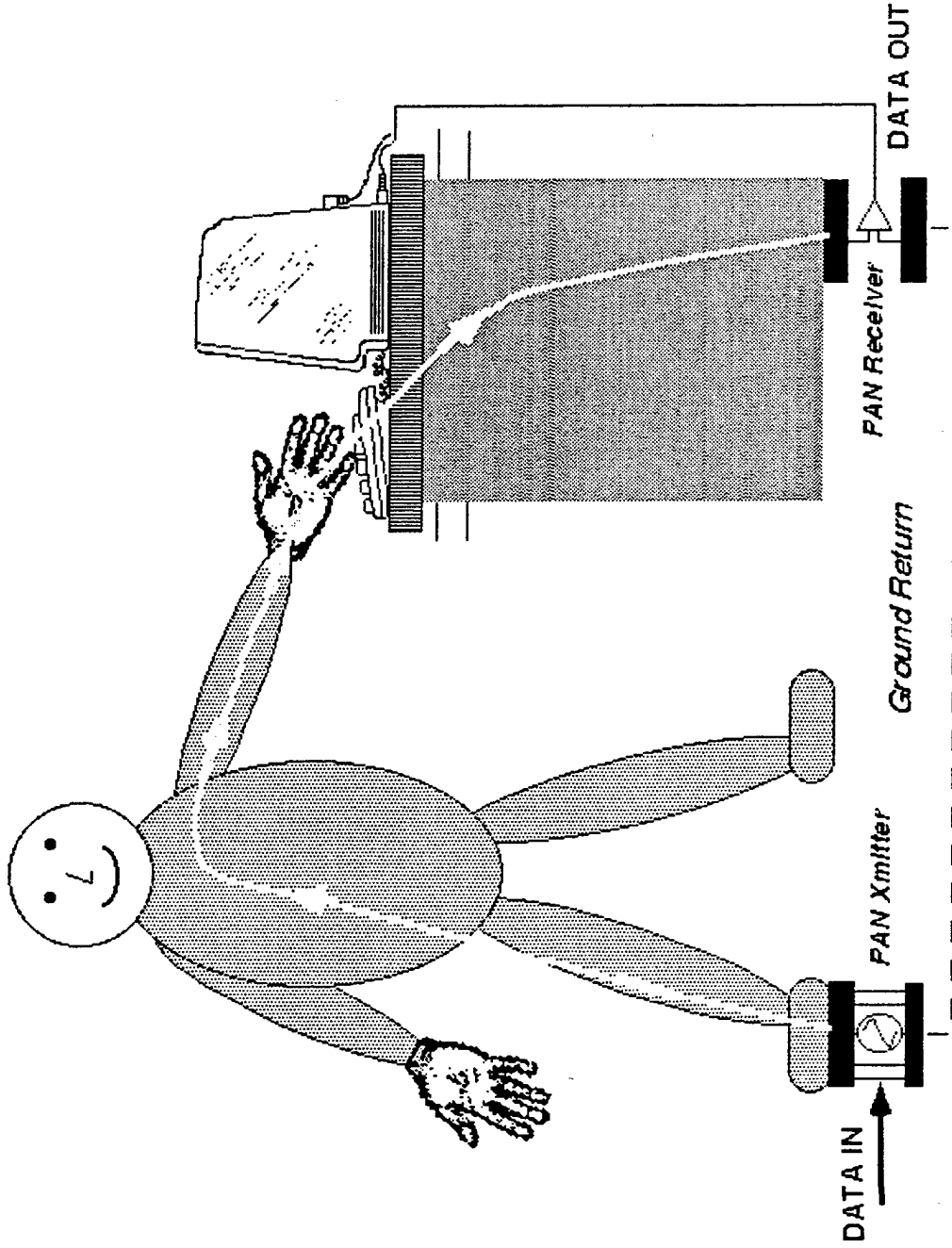

*Note: PAN transceiver can be embedded in PC keyboard*

# Inertial Energy Scavenging

- Conversion Technology
  - Displace Proof Mass with casual motion
  - Demonstrated in Seiko watch
  - Best to pump mechanically resonant system (e.g., pedometer)
- Modes: Anything
  - Feet, arms, legs, backpack, tools
- Energy levels
  - Seiko device is order of a milliwatt
    - 20-50 mW per device estimated possible; can do better w. resonance?
- Issues
  - Application in trickle-charge, distributed systems
  - Could be inefficient wrt. Power density (proof mass needed)
    - Exploit existing gear (backpack?) as proof mass
    - Ergonomics, irritation level
  - OmniMode device?
    - Wear for parasitic power, strap on crank for direct conversion

# Load and Charging Management

- Large disparity between average and peak loads
  - Mission dependent
    - e.g., special forces vs. infantry in battle
  - Impacts designs and choices for power sources
  - Load management critical
    - Consumers sleep until needed
    - Significant power needed only during brief “bursts”
    - Distributed vs. centralized
      - Low SS. Power requirements in each system
      - Independent harvesters (no wires...)

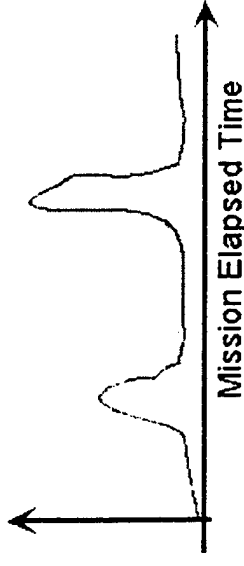

- Analogous situation with charging
  - Batteries, large capacitors don't want to charge fast
    - ESR losses, etc.
  - Continuous trickle-charge w. low-output electrical source
  - High-impulse mechanical input buffered, then metered out
    - Wind spring, lift mass, etc.

## Electromagnetic Generator

Energy Input	Energy Distribution	Conversion	Conditioning	Storage	Key Issues
Heel Strike	Boot plugs into pant leg	Transfer of Fluid/gas drives motor	Generator needs to be at about 10 V to absorb 3W with low loss	Batteries	Brief high level work must be buffered to keep resistive losses down
Exoskeletal braces	Battery charger on belt	Pawl drives sawtooth gear, winds spring that smooths out power flow			Continuous, low level work is OK as is.
Breathing	Constant dia belt with flex "baggies" on inner and outer surfaces				Generator needs high speed Viscous losses versus gear friction
Lifting Back-Pack against Gravity	Hang Backpack on tripod. String unwinds				
Sit on chair that sags		Winch or rack-pinion drives gen.			
Rocking chair/Rowing Mach					

### Waste Product Fuel Cell

Energy Input	Energy Distribution	Conversion	Conditioning	Storage	Key Issues
<p>Human Waste</p> <p>Watt Range</p> <p>.5 - 1 Watt</p>	<p>Fuel cell based on urine.</p> <p>Urea is broken down to NH<sub>3</sub> by bound enzyme, NH<sub>4</sub>OH drives fuel cell</p> <p>Human → 12 gm of urea/day</p> <p>→ 2NH<sub>3</sub> + O<sub>2</sub> → N<sub>2</sub> + H<sub>2</sub>O</p> <p>0.1M → 1M Reverse Osmosis</p> <p>~1V, 2W</p> <p>continuous by 1 human waste</p>	<p>None</p> <p>Correct voltage &amp; current</p>	<p>Individual steps have been demonstrated to work</p> <p>Electrode size needs to be determined</p>	<p>“Fresh” supply every day</p>	<p>Needs alkaline environment</p> <p>NaOH is a hazard</p> <p>Full system has not been demonstrated</p>

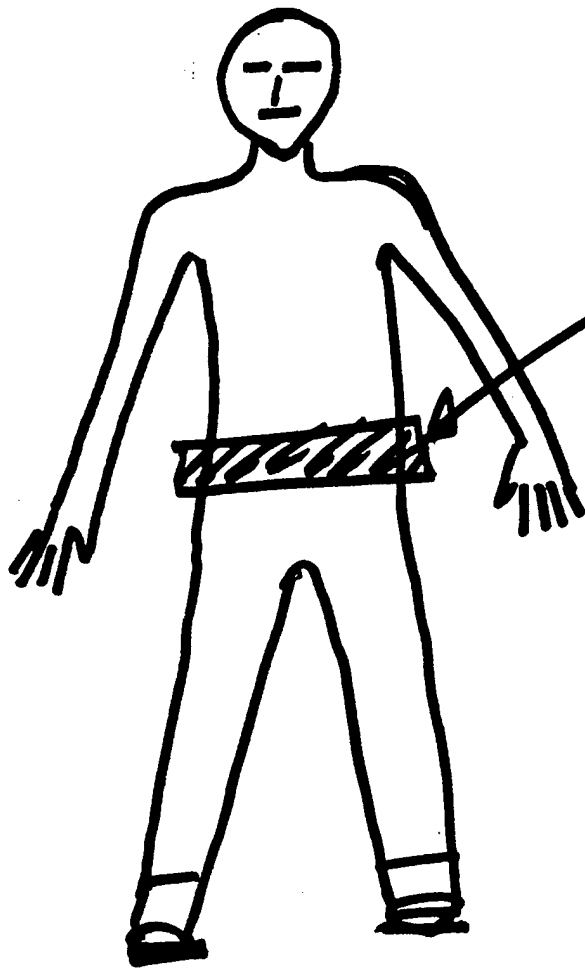

"HYDRAULIC BELT  
WORN ON UPPER  
ABDOMEN."

CONCEPT: FLUID FLOW  
BETWEEN INNER & OUTER  
RESERVOIRS THRU'  
HYDRAULIC MOTOR/GEN.

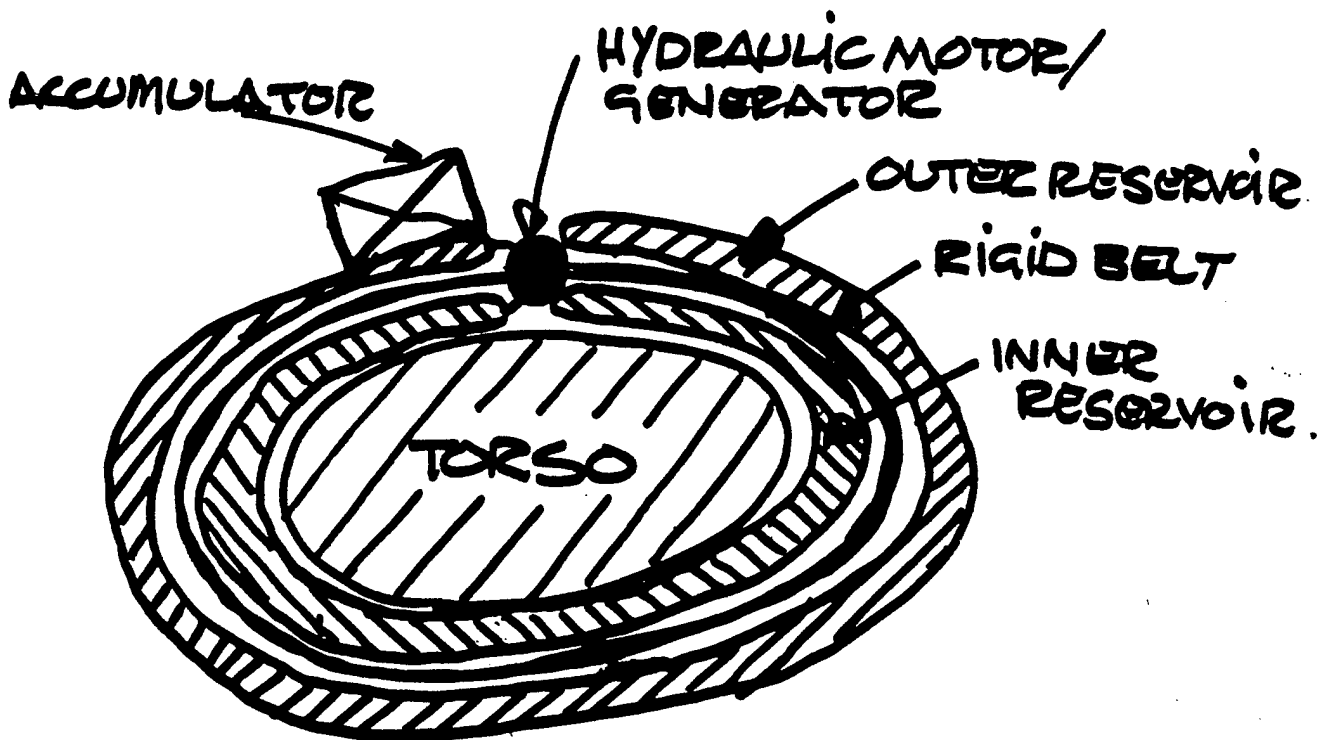

# "BAYREN" BOOT

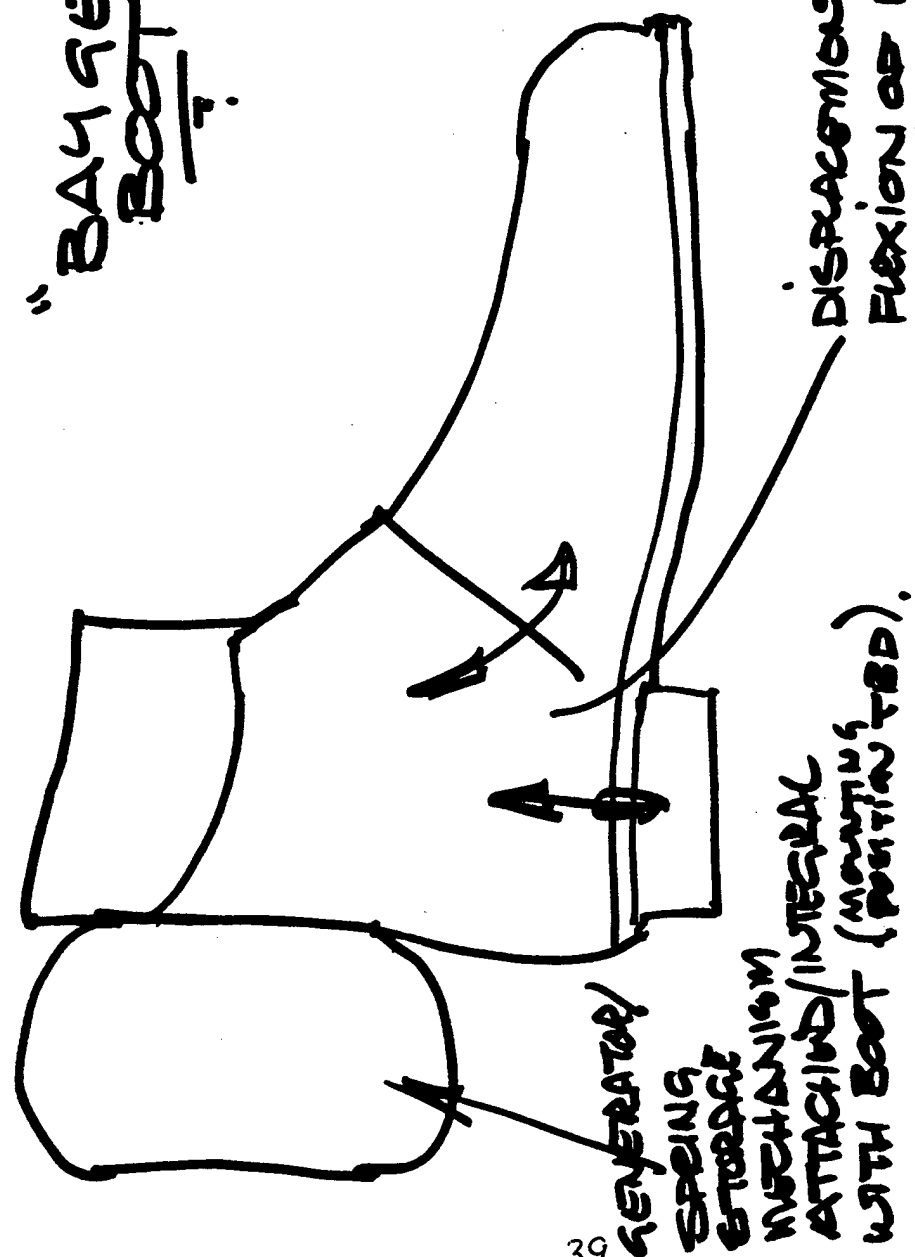

1) CONCEPT:

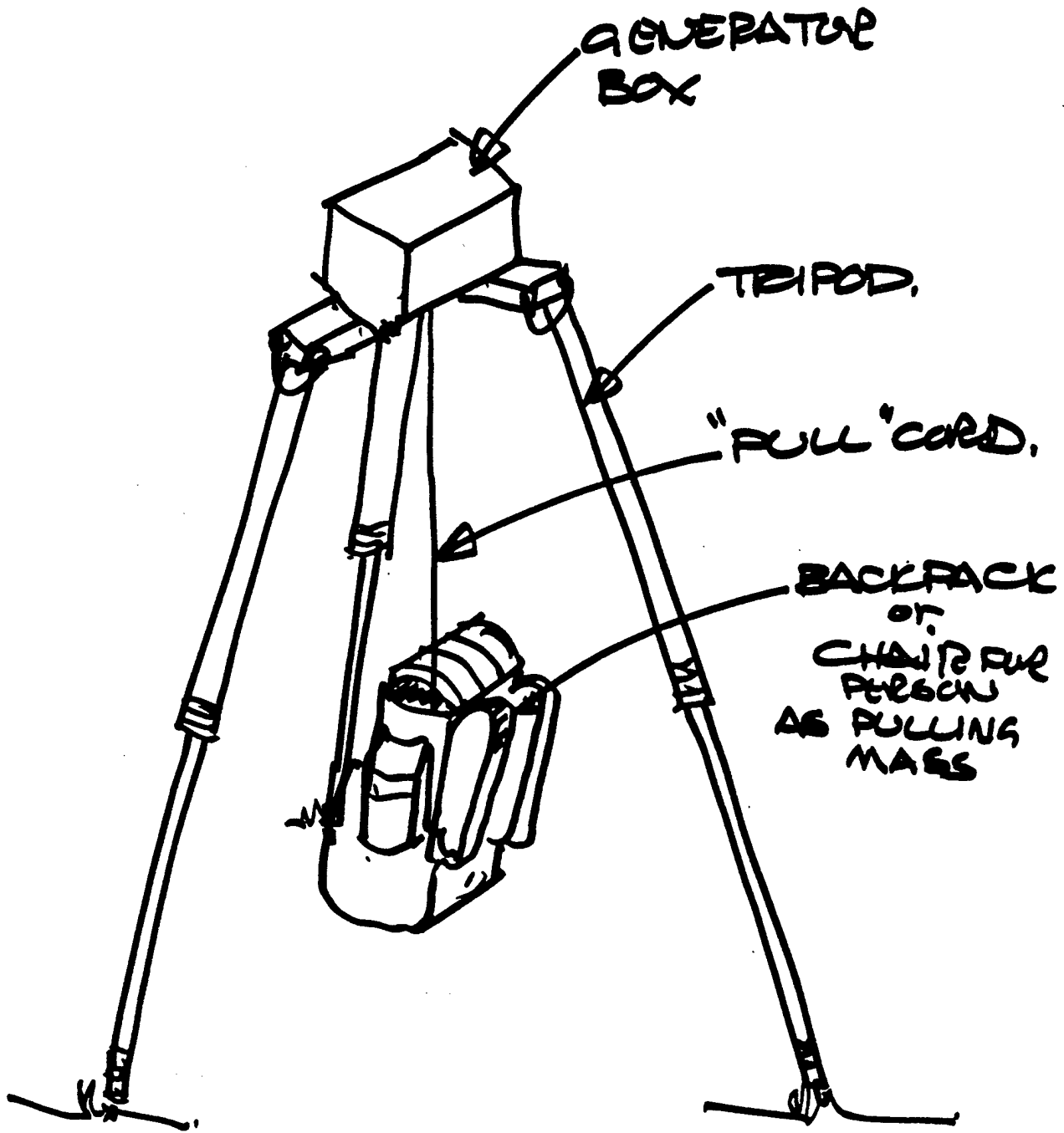

THIS CONCEPT MINIMISES FATIGUE OF CONTINUOUS HAND CRANK OF GENERATOR BOX .

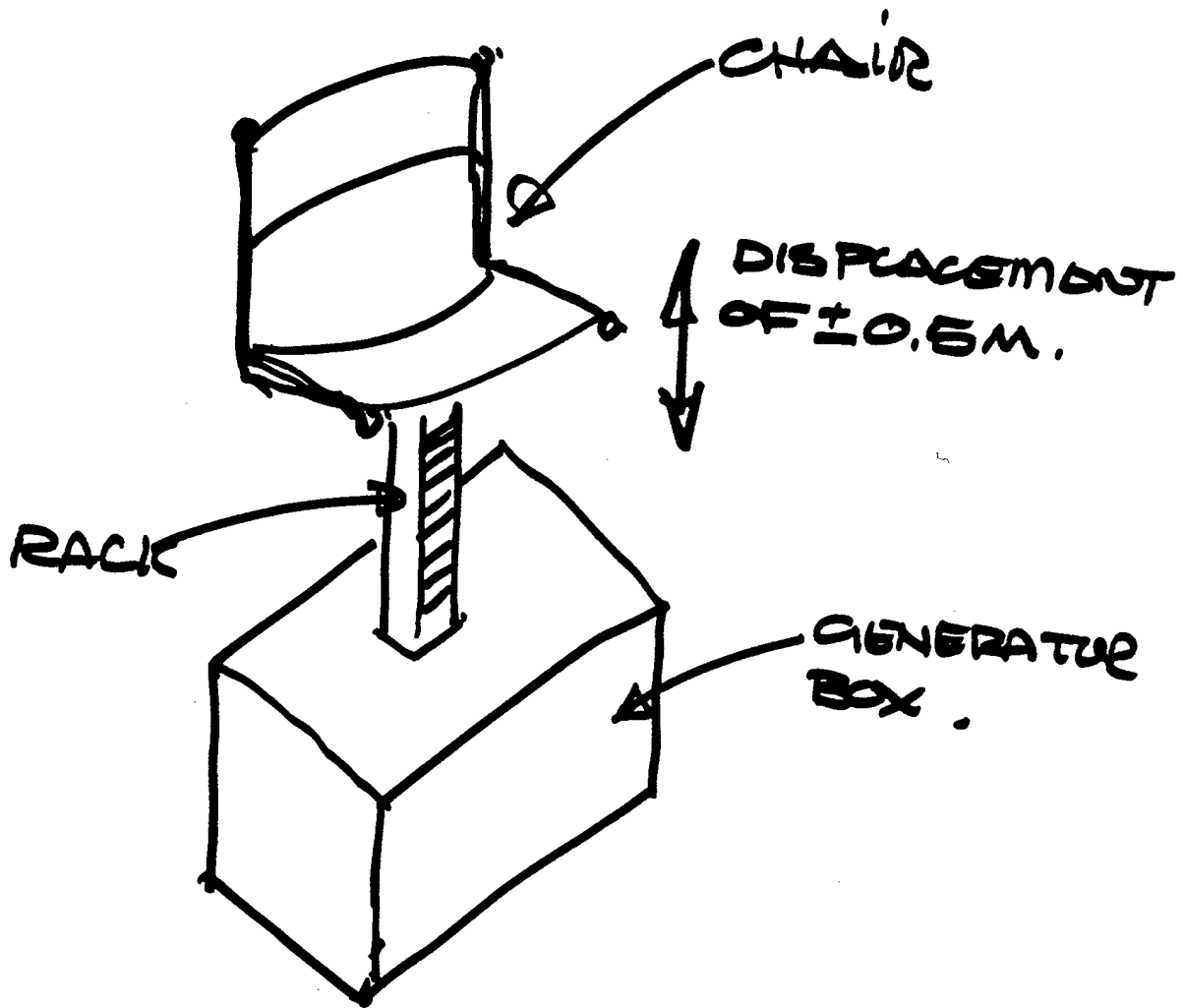

MASS OF PERSON DEPRESSES RACK,  
TURNING PINION. FOR DIRECT GENERATOR  
TURNING.

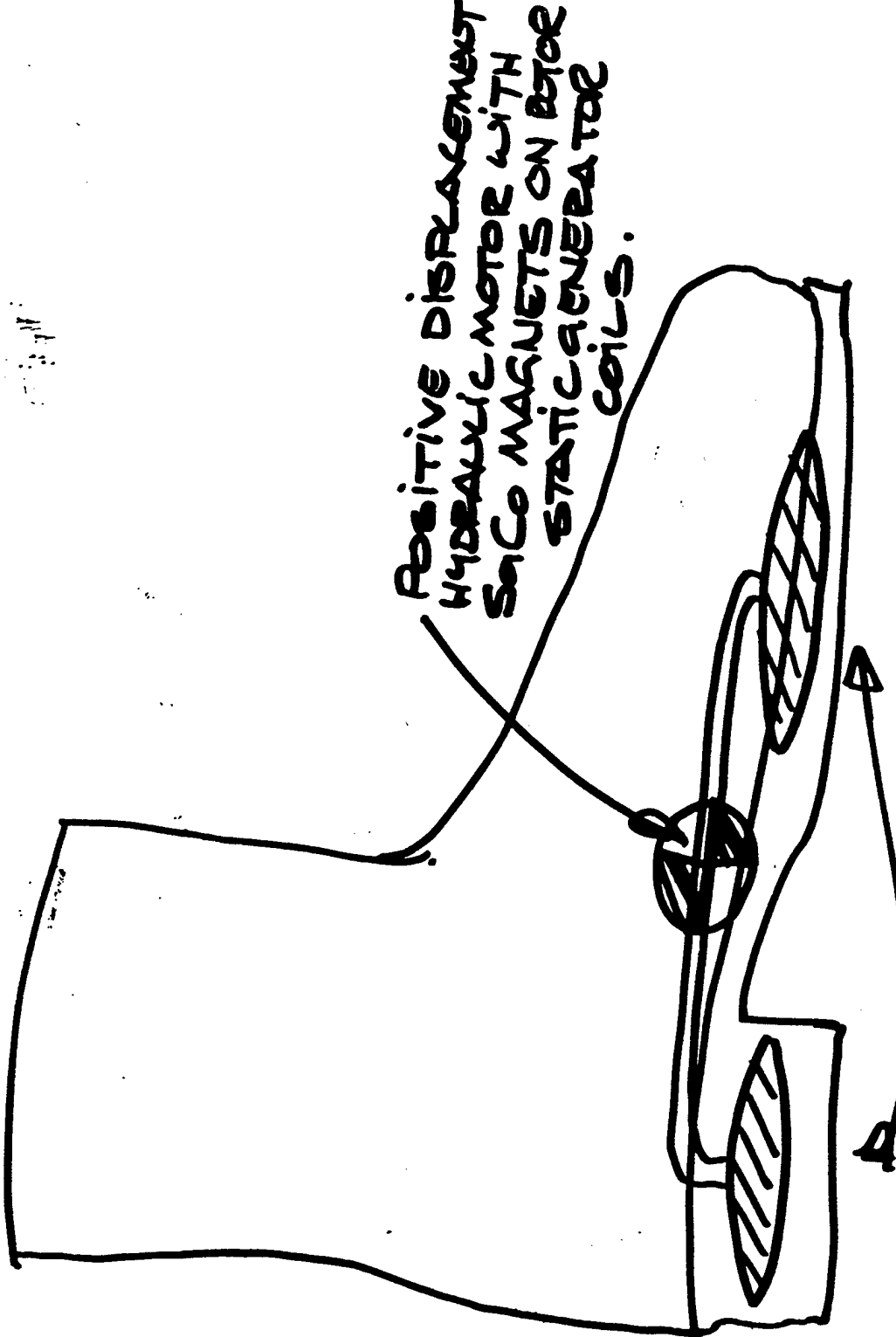

POSITIVE DISPLACEMENT  
HYDRAULIC MOTOR WITH  
SAFCO MAGNETS ON MOTOR  
STATIC GENERATOR  
COILS.

HEEL STRIKE TO THE TRANSFERS  
FLUID THRU' POSITIVE DISPLACEMENT  
MOTOR.

CONCEPT:

ROCKING CHAIR  
ROWING MACHINE  
?

FORWARD/BACKWARD  
OSCILLATION LINKED TO  
● GENERATOR (THEY  
SPRING STORAGE  
DEVICE?).

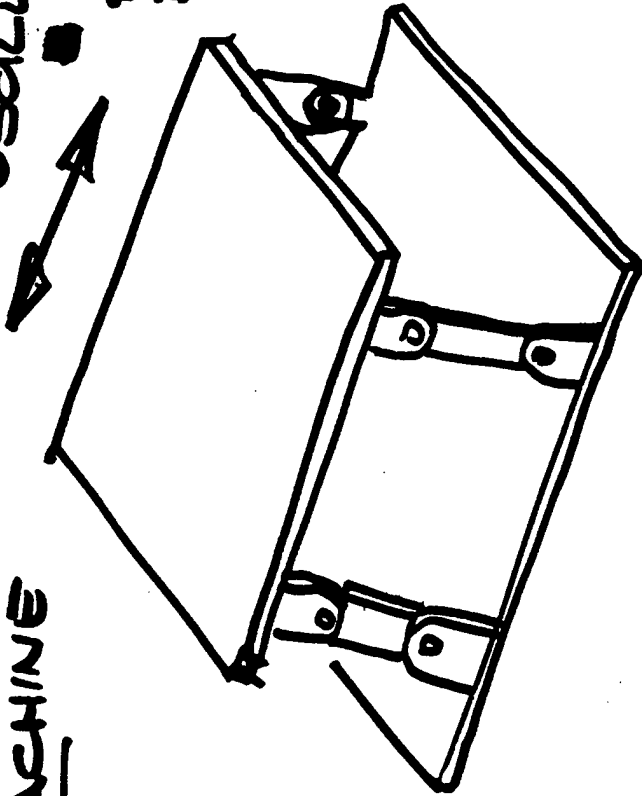

PERSON SITS ON PLATFORM  
TO FACILITATE OSCILLATION.



**WORKING GROUP 3 SUMMARY**

# RESEARCH

Research Area	State-of-Art	Developm't Potential	Risk	Priority
Human Body	Sports medicine Military Charaterization Performance Enhancement	Not done within the context of harvesting energy from the human body  Excellent potential		High

# RESEARCH

Research Area	State-of-Art	Developm't Potential	Risk	Priority
<p>Mechanical to Electrical Electromagnetic (generators)</p>	<p>Well established in small motors which are inefficient when used as a generator.  Few examples of small efficient gen.</p>	<p>Apply design rules for small motors to design generators.  Excellent improvements possible.</p>	<p>Low</p>	<p>High</p>
<p>Mechanical to Electric  Piezo-electro</p>	<p>Predominately used in actuators. New materials are being developed. Special applications where efficiency not an issue.</p>	<p>Research needed for new materials.  Issues of matching/coupling.  Development potential unclear.</p>	<p>High</p>	<p>Medium to High</p>
<p>Mechanical MEMS-Electric</p>	<p>Rapidly evolving in other fields. Mostly mechanical. Has not focussed on conversion to electricity. Major DOD/DARPA programs.</p>	<p>Development potential should be high. MEM fabrication techniques are well developed. Electrostatic generators.</p>	<p>Moderate</p>	<p>Medium</p>

# RESEARCH

Research Area	State-of-Art	Developm't Potential	Risk	Priority
Thermal to Electric Thermoelectrics	SOA well established in high T regime. Major DARPA/Navy Program for new materials operating near room temp.	Inherently low power low efficiency for low $\Delta T$ . Large area needed. (Pay off high)	High	Low
Chemical to Electric from waste	Bio fuel cells emerging. Digesters etc in large sizes mature. Not applied to human waste	High payoff from some military applications. Time constraints. Excellent potential	High	Medium to high

# RESEARCH

Research Area	State-of-Art	Developm't Potential	Risk	Priority
Storage Flywheels	Established over a wide range of sizes Mature	Mature with low potential in general. Development potential for bearings	Low	Low
Springs	Established over a wide range of materials. Approximate 1j/gm storage system 0.5 j/gm	Mature with development for <u>input</u> and <u>output</u> mechanisms	Low/ medium	Low
Batteries	Well established rapidly evolving technology. Focus on high energy density.	Smart batteries. State of health. Temperature and environmental issues. Excellent	Low/ medium	High

# RESEARCH

Research Area	State-of-Art	Developm't Potential	Risk	Priority
Storage Supercaps	Well developed in some devices. New materials are emerging prototypes on order of 20 j/gm 10kw/kg.	Need understanding of leakage mechanisms. Cell aging and balancing. Fabrication technique. Reliability. Excellent potential	Low	High
Distribution	Unclear piece/parts exist	Need architecture global architecture for solder. Excellent	Low/ High	High



**OVERVIEW SESSION 1**

**“SOLDIER SYSTEM IN 20 YEARS”**

**Mr. Robert O'Brien**

**Soldier Systems Command  
Natick, MA 01760**

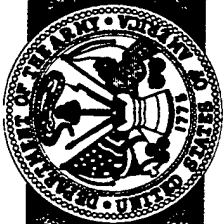

# Soldier Systems The Path to Army After Next



Briefing to  
Prospector IX Workshop:  
*Human Powered Systems*

Mr. Robert O'Brien  
Warrior Systems Group  
Soldier Systems Command

3 Novemebr 1997

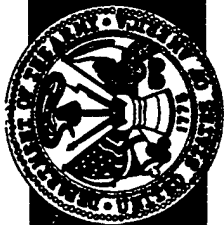

# **Soldier Systems Potential for AAN Land Warrior Consolidated Program**

## **Provides:**

- Digitization for the Dismounted Warrior
- Situational Awareness
- Target Acquisition and Automated Handover
- Improved Protection
- Enhanced Vision Capabilities

## **Subsystems:**

- Computer Radio
- Integrated Helmet Assembly
- Weapon (Includes sight)
- Protective Clothing and Individual Equipment
- Software

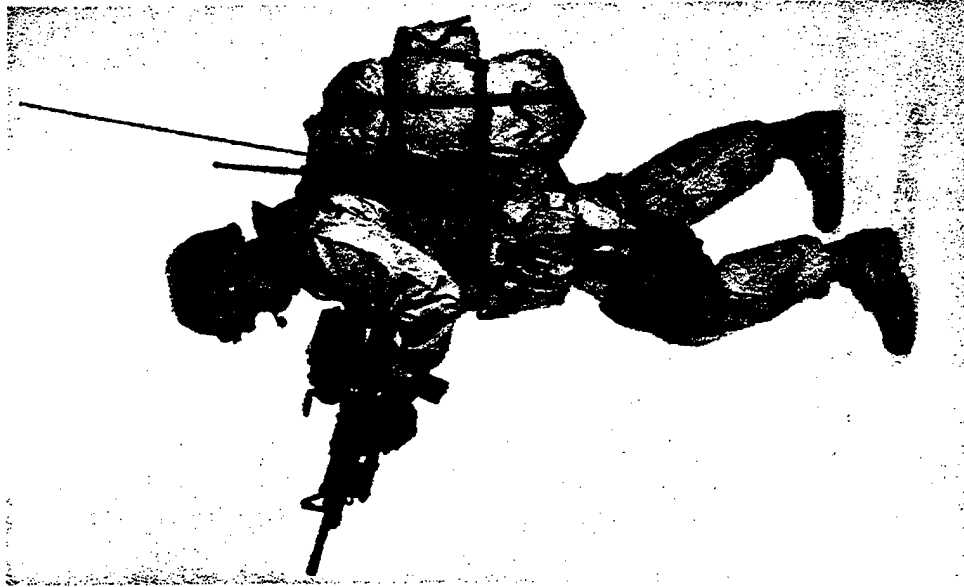

**Modular Integrated Fighting System for the Dismounted Warrior**



# Soldier Systems Potential for AAN Soldier Modernization

Science and Technology

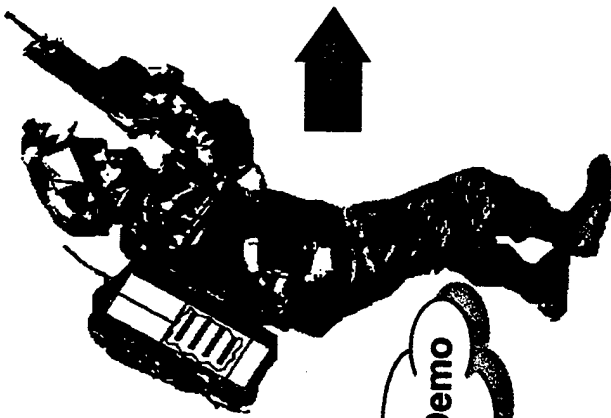

1992 Demo



GEN II ATD

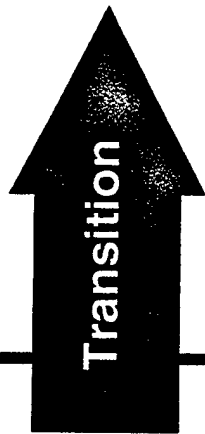

Engineering & Manufacturing Development

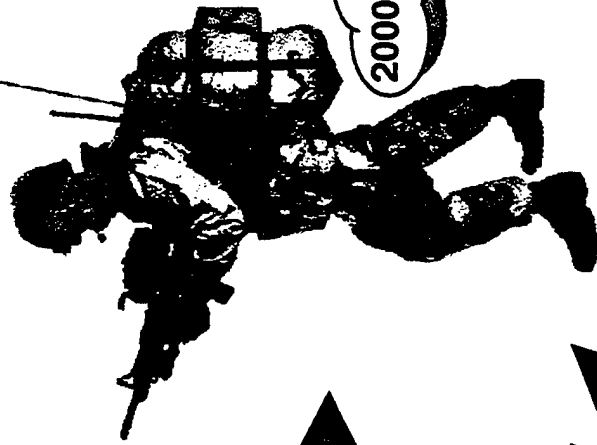

2000 Fielding

Land Warrior

## Force XXI Land Warrior

- Enhanced Range Soldier Radio
- Enhanced Weapon Interface
- Integrated Sight\*
- Integrated Navigation

## Provides Enhanced Capabilities

- System Voice Control
- Interface with Combat ID
- Head Orientation Sensor
- Helmet Mounted Display - Low Power Electronics
- Reduced Helmet Weight - Risk Reduction\*

\* Reduces weight

## S&T Provides the Foundation for Revolutionary Upgrade for the Soldier



# A Soldier System Path to Army After Next

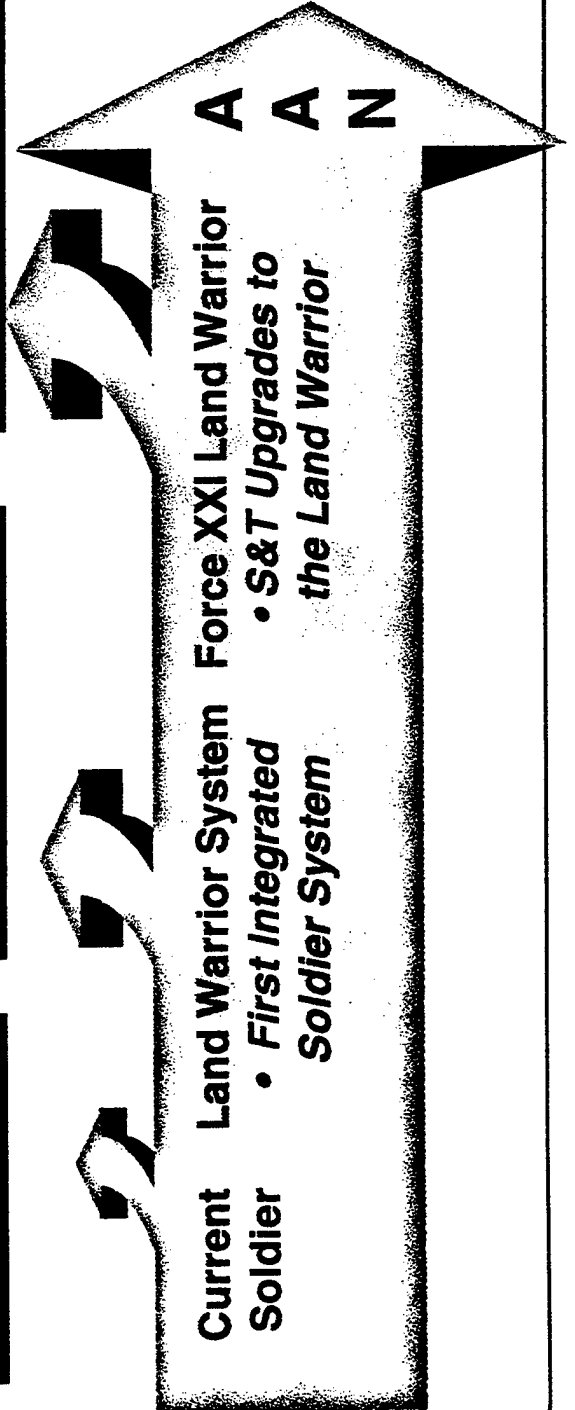



# Target Acquisition

- **Current Capability**
  - M16A2 Rifle
  - Line of sight scopes out to 600 meters



U.S. Army Photo Courtesy: USARPAC

- **Land Warrior Capability**
  - M16A2E4/M4E2 Modular Weapon Systems
  - Allows soldiers to acquire and hand over targets out to 1100 meters

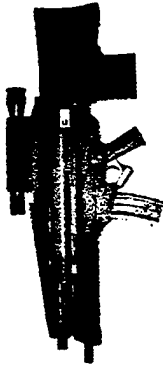

- **Army After Next Capability**
  - Automatically acquires and hands over targets to appropriate supporting weapon in all conditions, day/night, and through obscurants
  - Selectable lethality
  - Self-guided personnel projectiles
  - Hands Free Weapon System
  - Target recognition, tracking



**Future Technologies**

- S&T will add Objective Individual Combat Weapon which will provide 20mm exploding munitions capability to defeat targets in defilade
- S&T capability out to 2500 meters

**Dramatically Increased Soldier Lethality**



# Situational Understanding

## • Current Capability

- Soldier vision, hand signals, word of mouth capabilities



## • Land Warrior Capability

- Linkage to digital battlefield, known enemy, friendly positions available and displayed on digital maps within heads-up display
- Real time data updates available from higher echelons



## • Army After Next Capability

- Complete full time link to all available battlefield assets, automatically selected for unit, position, and mission
- Holographic Imaging/Decoys,
- Complete sensor fusion (thermal, image intensifiers, geolocation, etc.)
- Preposition sensor capabilities
- Wide Band Mobile Internet, Manportable Mini-Base Stations
- Counter Sniper
- CB Sensors





# Maneuver

- **Current Capability**

- 75 pound fighting load, paper maps, compass, stand alone GPS unit (PLGR)



- **Land Warrior Capability**

- 75 pound fighting load with advanced capabilities, digital maps linked to integrated GPS
- Allows soldiers to move more accurately and quickly
- S&T effort will integrate additional positioning capability when GPS not available

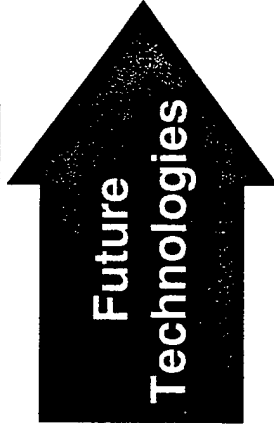

- **Army After Next Capability**

- Dramatically reduce overall system weight with even more capability, ~ 50 lb fighting load
- Automatically selects best route, predicts enemy movements and counter maneuvers
- Dramatically increase movement rates with mechanical assist, or individual/group transporters
- Exact airdrop insertion for troops/units
- In Stride Mine Avoidance

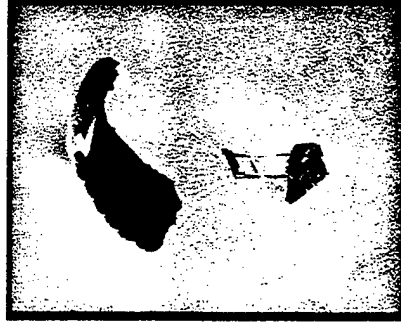



# Warrior Protection

## • Current Capability

- Protection from air burst munitions to head and torso, direct fire munitions to torso
- Multiple layer/component approach to provide environmental/chemical protection



## • Army After Next Capability

- Fully integrated protection to reduce bulk, logistics, and weight, Spray-on Second Skin
- Signature Control (Near/Mid/Far IR, Visual, Acoustic, Radar, Chameleon)
- Protection from direct fire munitions to head and torso at a dramatically reduced weight
- Advanced Physiological Monitoring (e.g., muscle response/fatigue, vital organ functions, etc.)

## • Visual, near IR countersuveillance

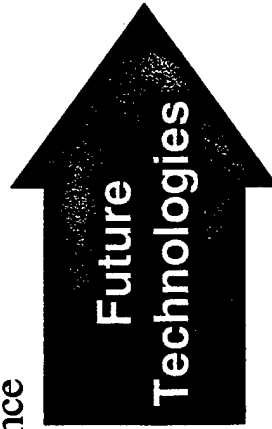

## • Land Warrior Capability

- Same capabilities at a slightly reduced weight
- S&T will provide Combat ID functionality



Identification of friendly, enemy or non-combatants





# Sustained Operations

## Power is Limiting Capability

- Current Capability
  - 12-24 hours of sustained operations without re-supply (METT-T dependent)
- Land Warrior Capability
  - 12 hours of sustained operation without re-supply with four batteries (3 pounds) with enhanced capabilities

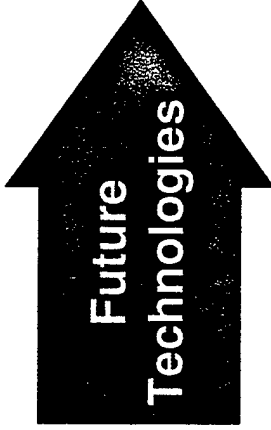

- Army After Next Capability
  - ~7 days of sustained operations without re-supply
  - New power sources (micro-turbines, etc.) provide revolutionary increase in manportable power capability
  - Renewable power sources

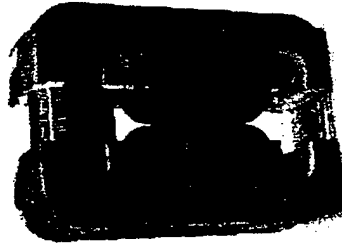

**Compact Power Sources**

The Portable Power Burden for 10 KWhr of Electrical Energy

60 Kg

15 Kg

4 Kg

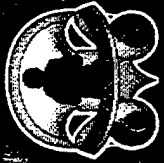

## Dismounted Warrior System Power & Energy



- **Current LW system projections (FY00):**
  - Three BA-5847C/U LiSO2 Primary Batteries Required to operate for 12 hours
    - One on weapon, two man-worn
  - BA-5847C/U Data:
    - Weight = 11 ounces, Volume = 14.62 in<sup>3</sup>
    - Capacity = 38 Watt Hours @ room temp.
    - Fused at 3 Amps
    - Between 12 and 16 Watts available depending on Battery “freshness”
    - Capacity at Low Temps are problem area
      - Losses near 50% at 0 degrees C
- **Typical 72 hour mission requires 18 BA-5847C/U Batteries per soldier**
  - 12.4 pounds & 263.25 in<sup>3</sup> of batteries



# Dismounted Warrior System Power & Energy



- **Largest Life Cycle Cost Driver for the Warrior System is Batteries**
- **What will help in the future?**
- **Technology**
  - Lower Power Electronics & Sensors
  - Improved Power Management Software and Techniques
  - Incremental Improvement in Battery Chemistries & Rechargeable technologies
  - New Power Sources
    - Fuel Cells
    - Human Powered Augmentation
    - Other “sleepers” (e.g., breakthrough in Solar, etc.)



## **Dismounted Warrior System Power & Energy**



- **Adjustments to Tactics, Techniques and Procedures (TTPs)**
  - Task Organize, Trade Offs on Basis of Issue
- **Adding Capability to the Warrior System as Technology Advances makes the challenge more Significant**
- **Beginning in S&T & Continuing to Fielding Future Systems the Army Must Maintain Strong System Engineering and Discipline**
  - Make Trade offs & Technology Improvements needed to bring the warfighter capability that is:
    - Light Weight, Affordable and Fightable

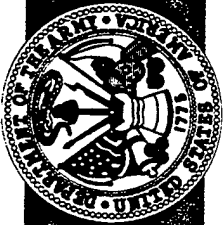

## ***What Questions Need to Be Answered?***

- ***How Will These Revolutionary Changes for the Warfighter Change the Way We Fight?***
- ***What Is the Right Mix of Technology To Maximize the Payoff?***
- ***How Do We Keep From Overwhelming the Dismounted Warfighter?***

**“FUTURE REQUIREMENTS FOR THE DISMOUNTED  
SOLDIER”**

**Mr. Rudolf G. Buser**

**CECOM  
Ft. Monmouth, NJ 07703-5201**

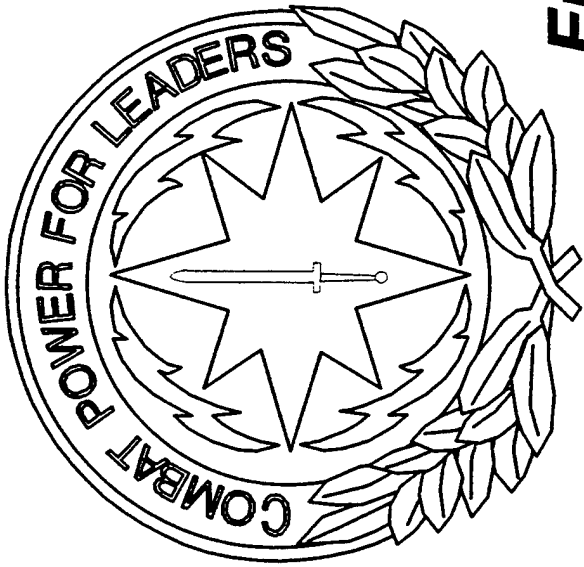

***Future Power Requirements  
for the Dismounted Soldier***

**Dr. Rudolf Buser**

**Communications - Electronics Command  
Research, Development & Engineering Center  
Fort Monmouth, New Jersey**



# FIELD CONCERNS

**Battery  
Costs**

**Improved  
Performance**

**Disposal**

**Recharging**

**Weight**

**Unused  
Capacity**

**Maintenance**

**Proliferation**





# Soldier System Exit Criteria



Program	System Weight	Technical Approach	Energy Req.	Battery	Weight
Land Warrior	20 kg	Modular Weapon System Laser Range Finder Thermal Sight Weapon Combat ID Soldier Computer Soldier Radio GPS HUD	720 WHrs (72 Hrs) 8 W nominal	BB-2847 Li-Ion	24 lbs
SUO	<1 kg	Geolocation/Clocks Situational Awareness Sniper Detection Ground Sensor Tactical Comm.	450 WHrs (72 Hrs) 5 W nominal	BB-2247 Li-Ion  BB-X847 Li-Poly	11 lbs  7 lbs
FXXILW	<20 kg	Enhanced Land Warrior Capabilities Wireless Weapon Interface Integrated Sight Voice Control Enhanced Radio Range Integrated Navigation	<450 WHrs (72 Hrs) 5 W nominal	BB-2847 Li-Ion  BB-X847 Li-Poly	11 lbs  7 lbs



# Soldier System Exit Criteria

**Program**      **System Weight**      **Technical Approach**      **Power Req.**      **Battery**      **Weight**

---

Mounted Warrior	TBD	Leverage Existing Programs CVC Helmet Helmet Display Wireless Comm Uniform Ensemble	TBD	TBD	TBD
Urban Warrior	TBD	Leverage Existing Programs	TBD	TBD	TBD
ELB	TBD	Leverage Existing Programs COTS	TBD	TBD	TBD
MOUT ATCD	TBD	Leverage Existing Programs COTS, GOTS Integrated Protection Laser Protection Signature Control Combat ID Telemedicine	TBD	TBD	TBD



# Current Programs

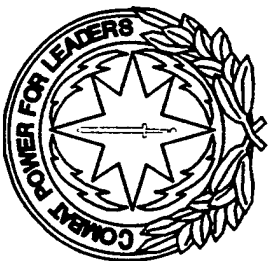
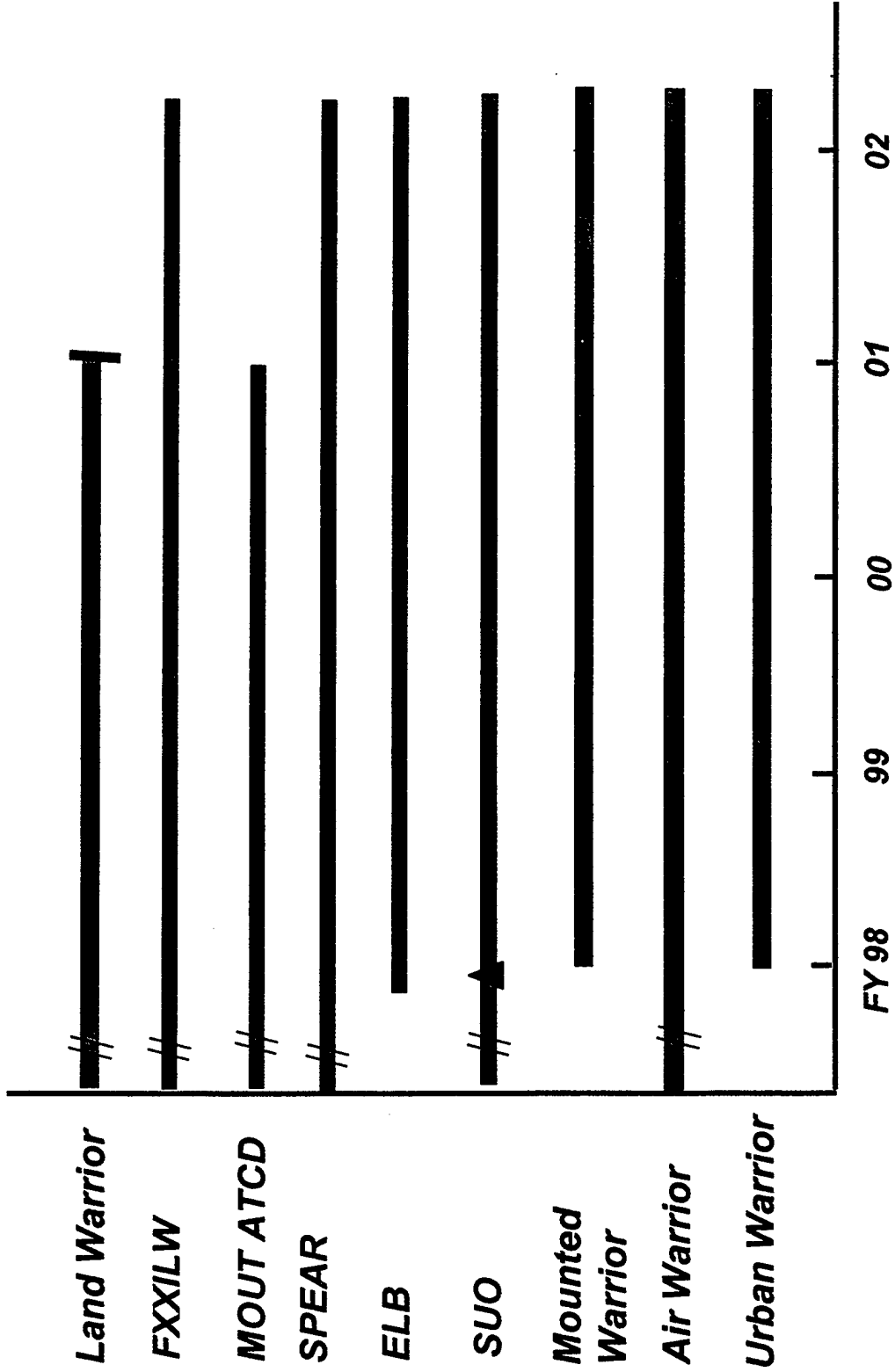

# Present and Planned Battery Charging on the Battlefield

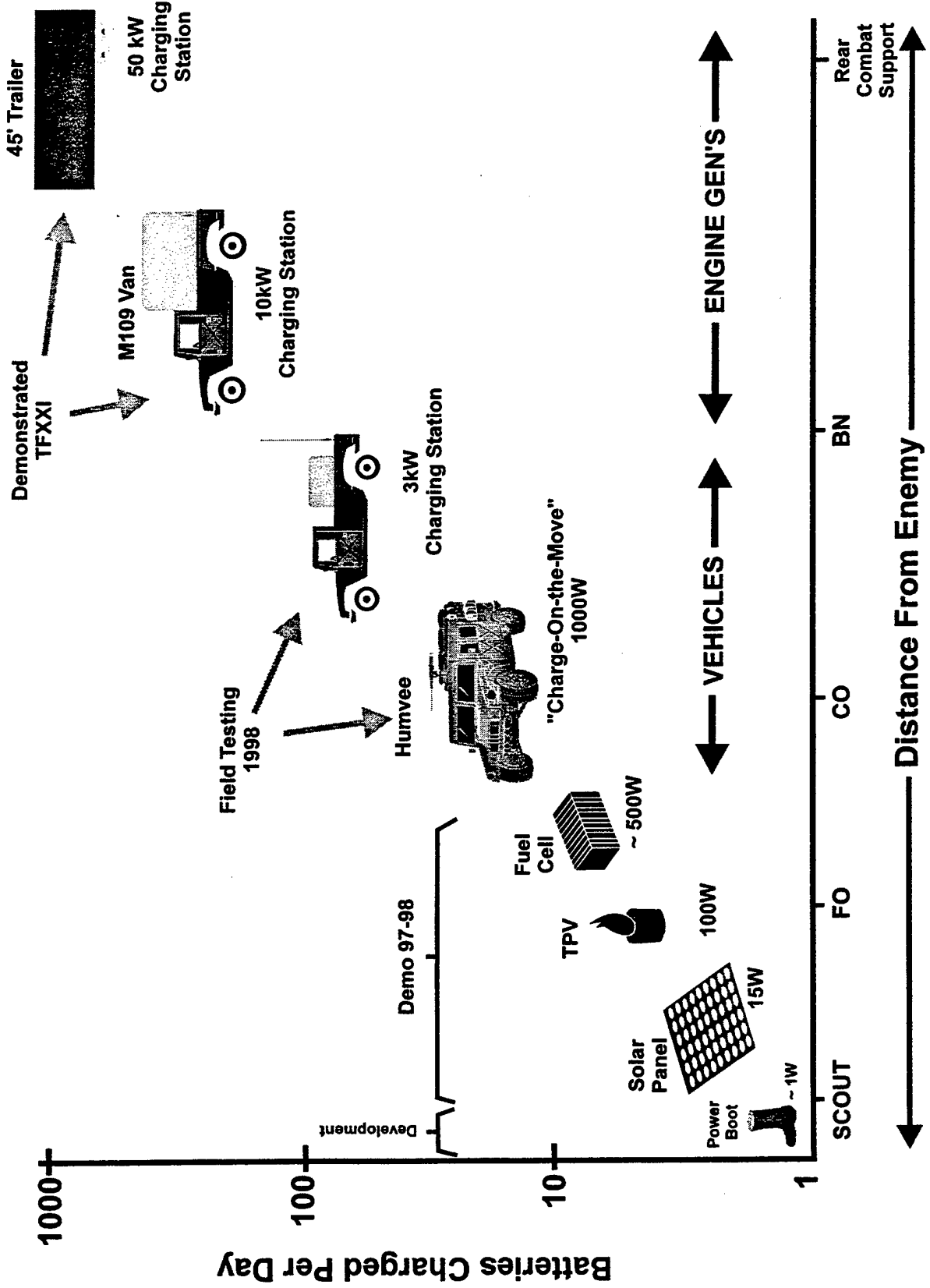



# Power Management

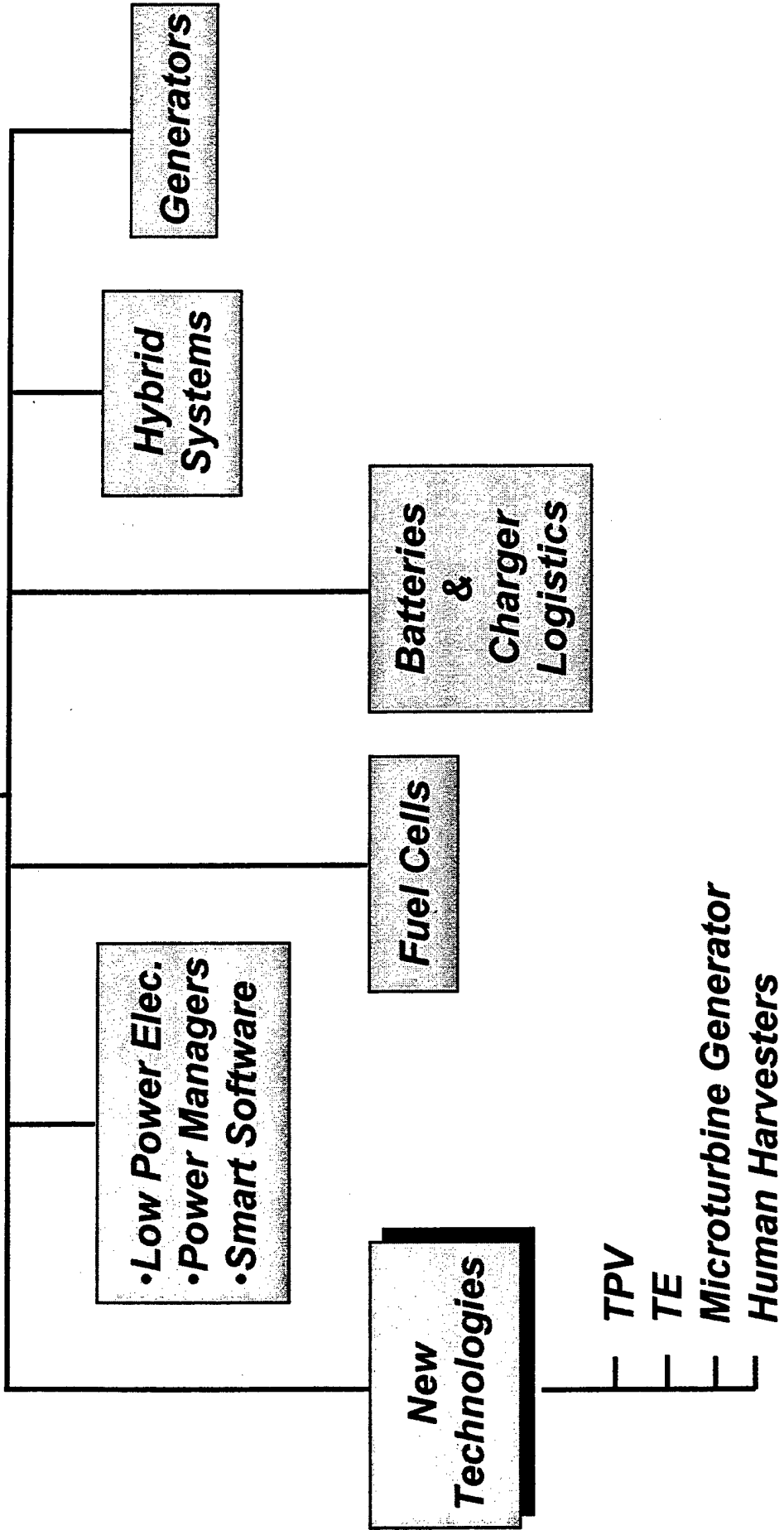



# Power Improvements

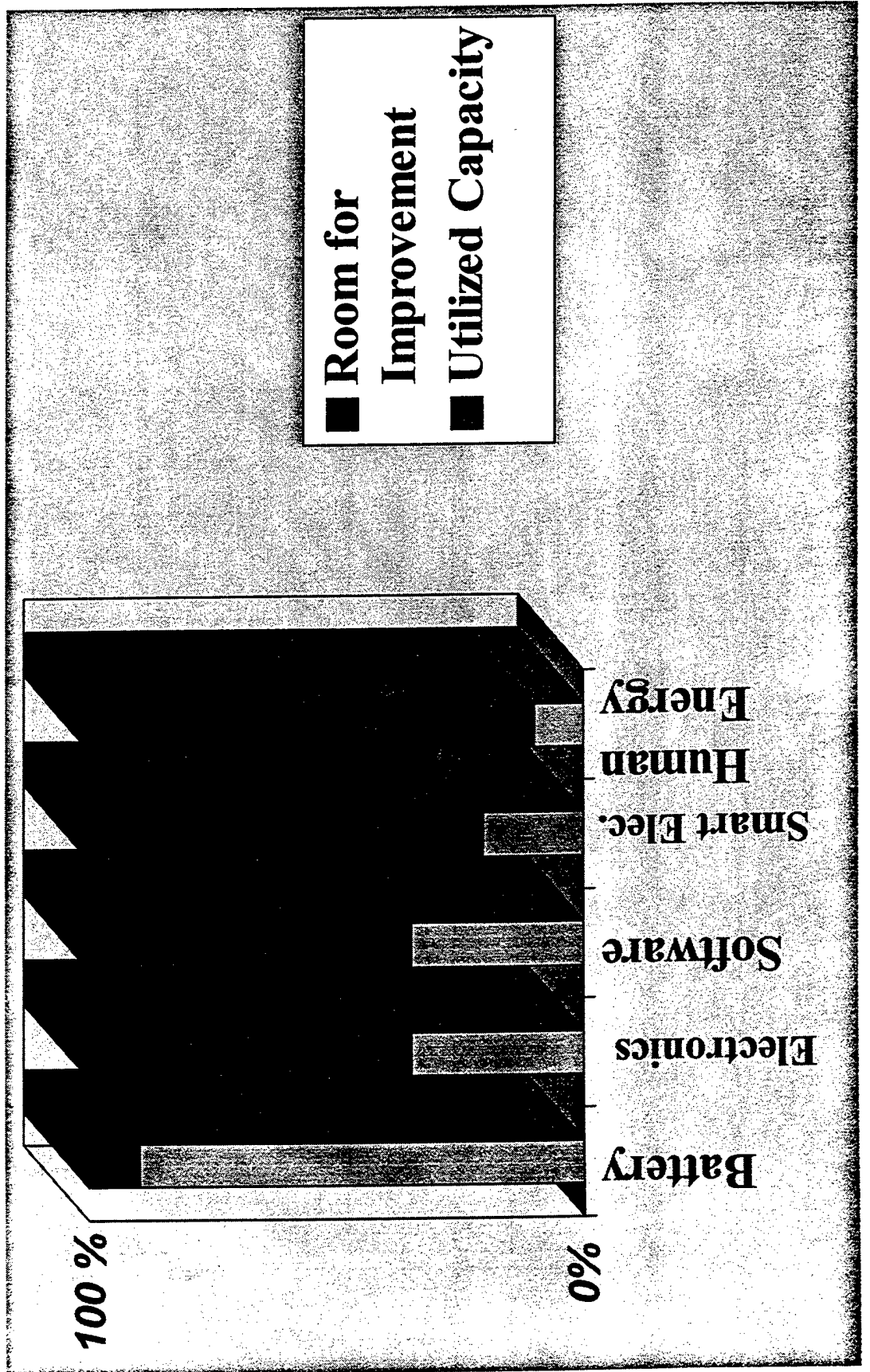

# ADVANCES IN RECHARGEABLE BATTERIES

Goal  
for 1/2 Size SINGGARS

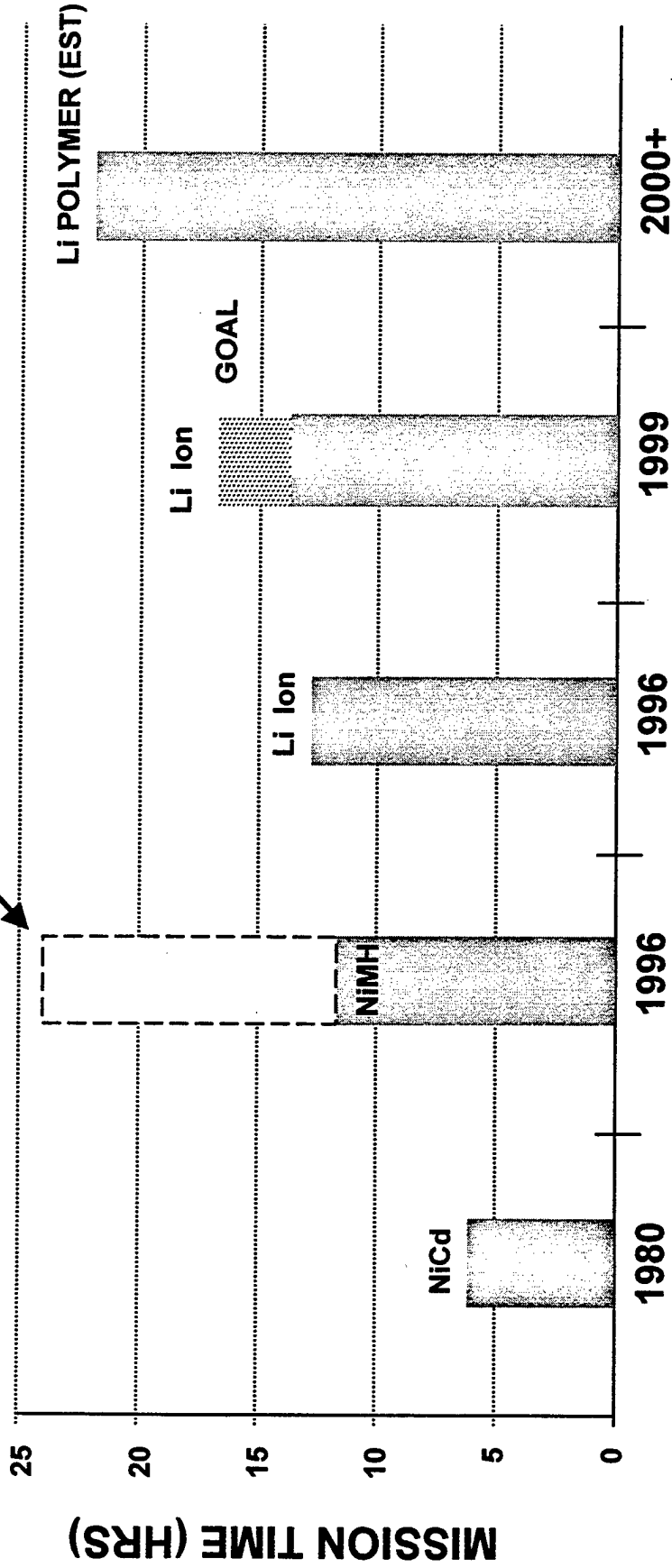

DATA BASED ON USE IN THE CURRENT SINGGARS RADIO



# Meeting the Power Needs

System	Nominal Power	Total Energy	Power Srce	Battery Wt
Land Warrior + TWS	8 Watts for 72 hours 6 Watts for 24 hours	720 Watt-hours	BB-2847/U Li-Ion	24 lbs
SUO + TWS OR FXXILW + TWS	5 Watts for 72 hours 3 Watts for 24 hours	432 Watt-hours	Li-Ion	11 lbs
SUO + TWS OR FXXILW + TWS	5 Watts for 72 hours 3 Watts for 24 hours	432 Watt-hours	Li-Polymer	7.2 lbs
Revolutionary LW + TWS	1 Watts for 72 hours 3 Watts for 24 hours	144 Watt-hours	Li-Polymer	2.4 lbs



# Batteries Only Versus MIPS Approach for Future Power

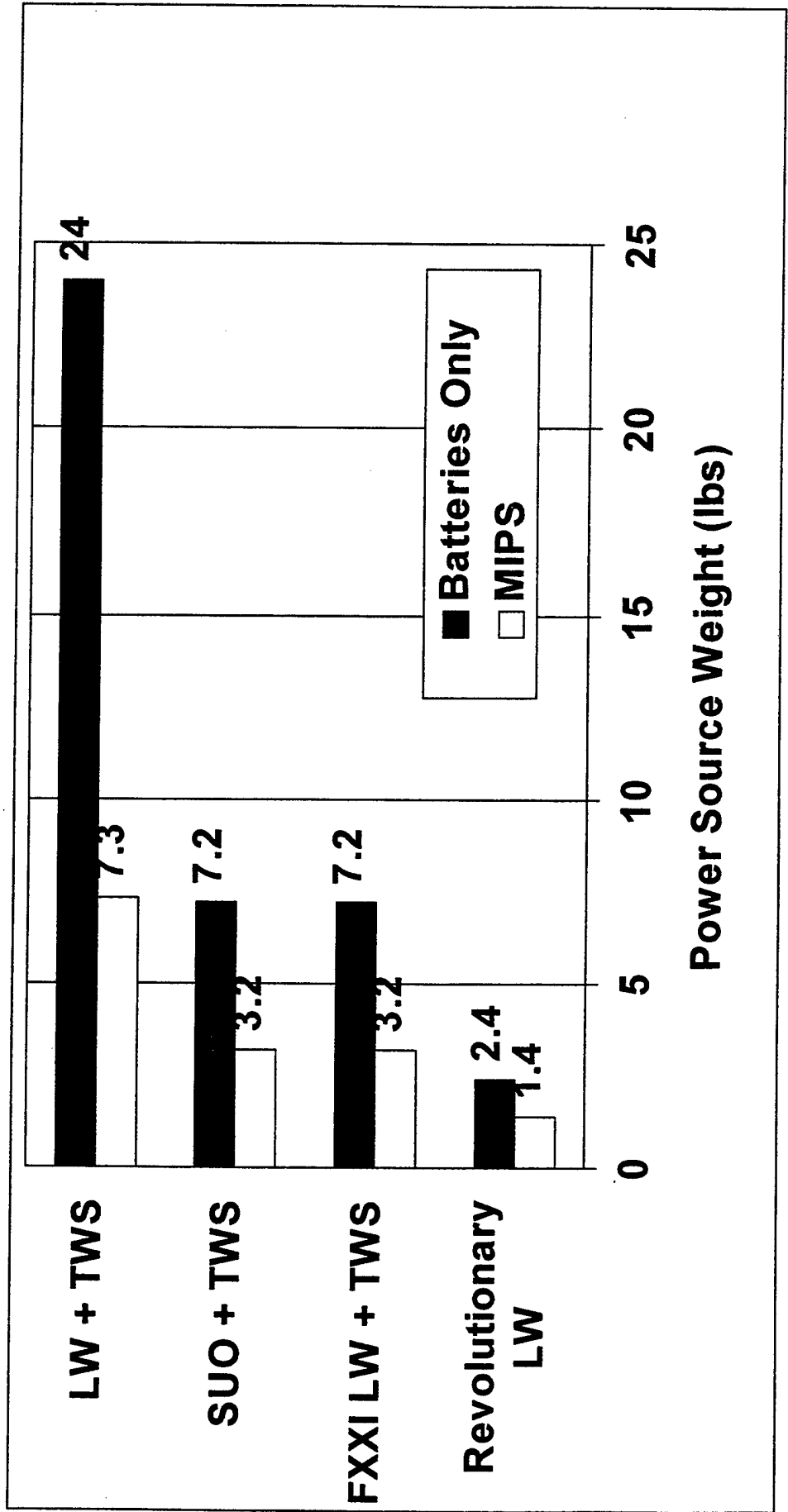

# MODULAR INTEGRATED POWER SYSTEM CONCEPT

- Integrated Manportable Charger/Battery System
- Battery recharged in 2 to 3 hours
- Battery operate equipments for 4 to 5 hours
- Charger refueled every 3 or 7 days
- Power boot and Solar Panel extends life of charger fuel

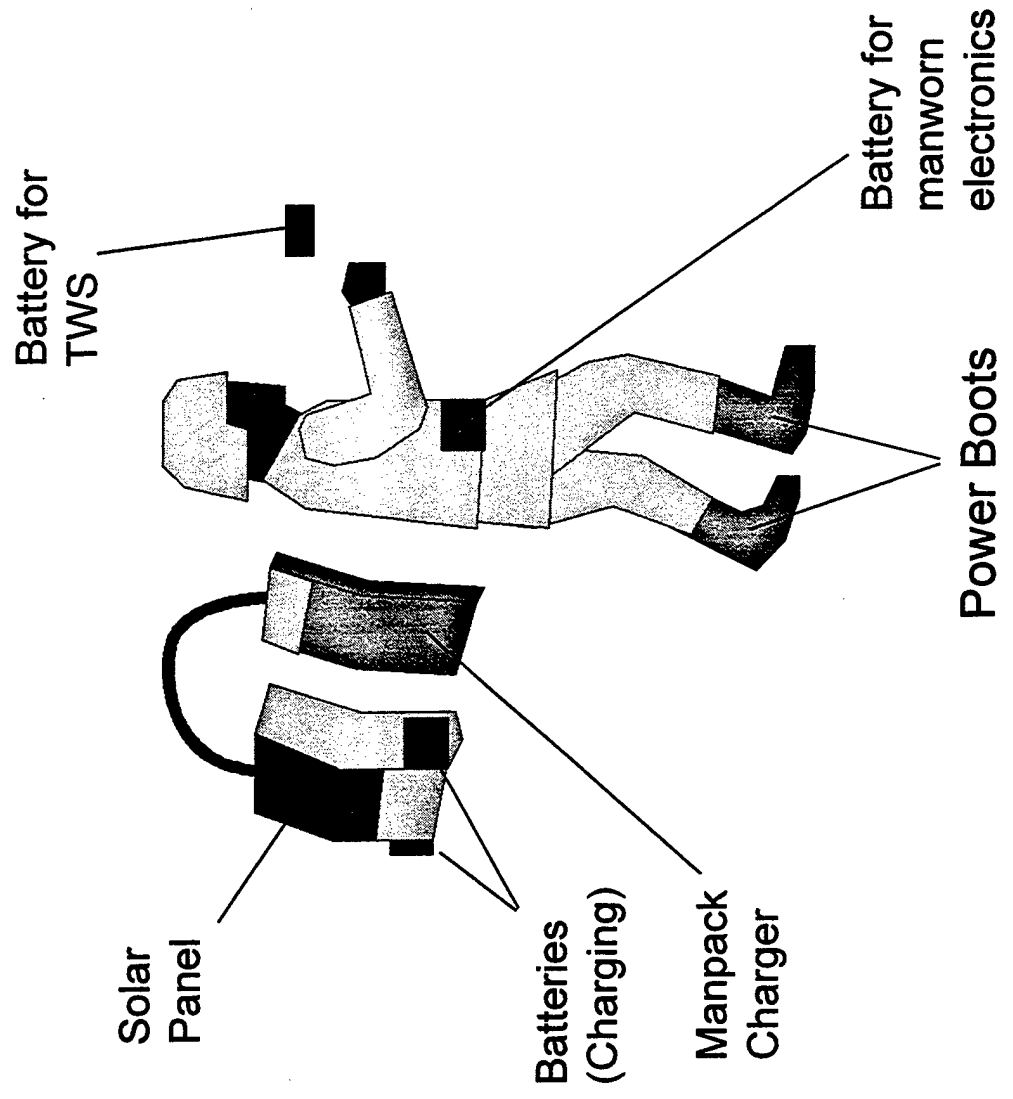



# Conclusions



- \*Effective Power Management Provides Key to Soldier Platform Optimization**
- \*Interim Expectations:**
  - \*Battery Improvements**
  - \*Evolution of Fuel Cell / Battery Hybrids**
  - \*Introduction of Human Energy Harvesting**
  - \*Significant Impact on Power Consumption by Electronics, Smart Electronics, and Smart Software**
- \*Appetite involving increased power consumption must be considered**



**“POWER FOR THE DISMOUNTED SOLDIER - A SUMMARY  
OF THE NRC STUDY”**

**Dr. M. Frank Rose**

**Space Power Institute  
Auburn University, AL 36849**

---

---

# *Prospector IX - Human Powered Systems Workshop*

*"A Brief Summary of the NRC Study of Power for the  
Dismounted Soldier"*

**M. Frank Rose, Director  
Space Power Institute  
231 Leach Science Center  
Auburn University  
Auburn, AL**

## Desert Storm

- Army shipped 2.2 million tons dry
- [REDACTED] total was ammo, mainly arty
- Army returned 1.6 million tons dry
- Not clear what was fired at enemy
- USAF delivered 70,000 tons of ordnance; 40 tons of fuel per ton delivered

## Our Vision: in 20 Years.....

- Early Entry Forces 33% of current manning
- *“Depopulate the zone of vulnerability”*
- Firepower 100% that of present force
- *“Situational understanding, precision fires...”*
- Teeth-to-tail ratio (in-theater) > 1.0
- *“Less vulnerability to asymmetric counters...”*
- Logistics just-in-time vice just-in-case
- *“Total asset visibility, precision delivery...”*
- Maintenance by need vice schedule
- *“Detect, remove, replace, as tele-coached...”*
- Acquisition driven by the engine of commerce
- *“Market oriented—like business...”*

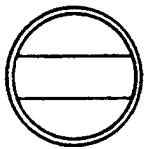

# CHANGES IN THE ART OF WAR FOLLOW TECHNOLOGY DRIVEN CYCLES

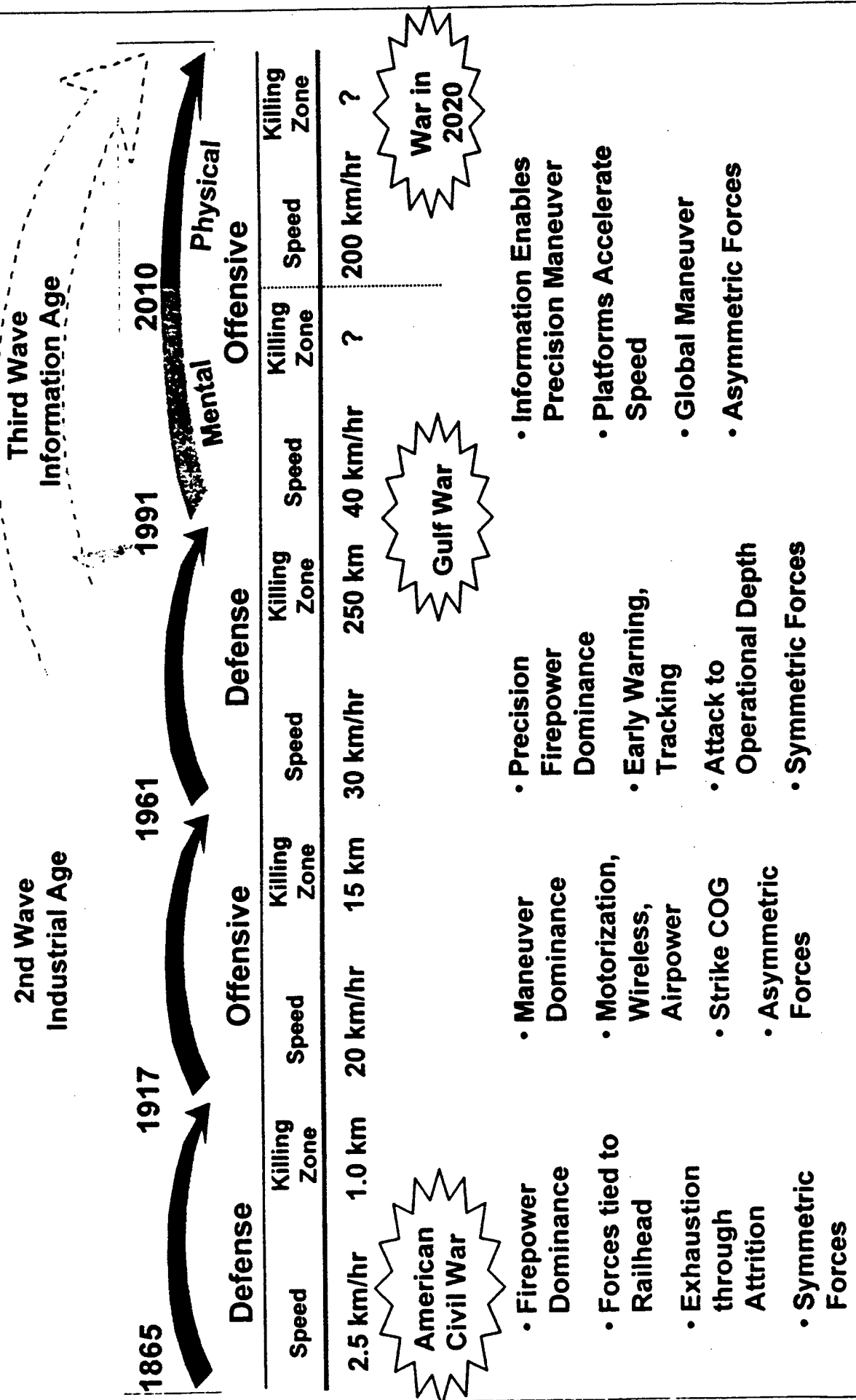

# 21st Century Power Projection

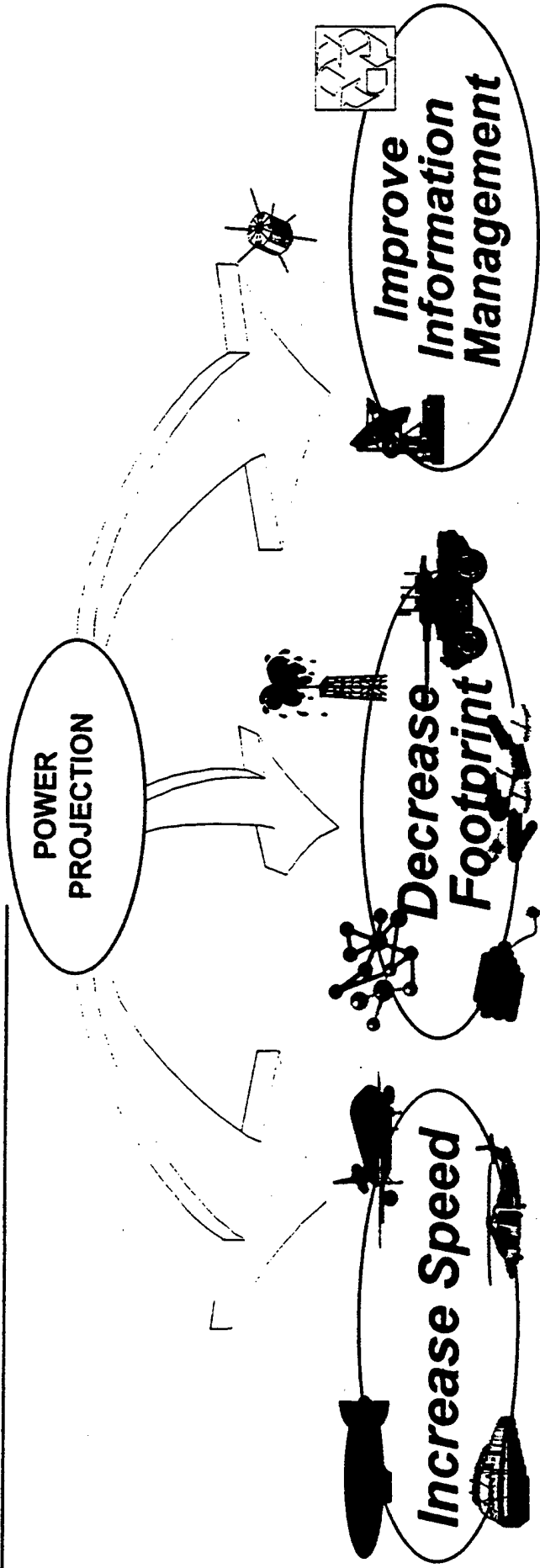

- High Speed Ships
- Next Generation Strategic Airlift
- Self-Deployable Tactical Multi-Role Aircraft
- Super Efficient Intermodalism
- High Speed Land Movement
- Lightweight Composite Materials
- Alternative Munitions
- Condensed Rations
- Alternative Power
- Super Efficient Engines
- Full Dimensional Awareness
- Infosphere Databases
- Total Process Simulations
- Transportation Based Distribution

# Prospector IX - Human Powered Systems

## Workshop

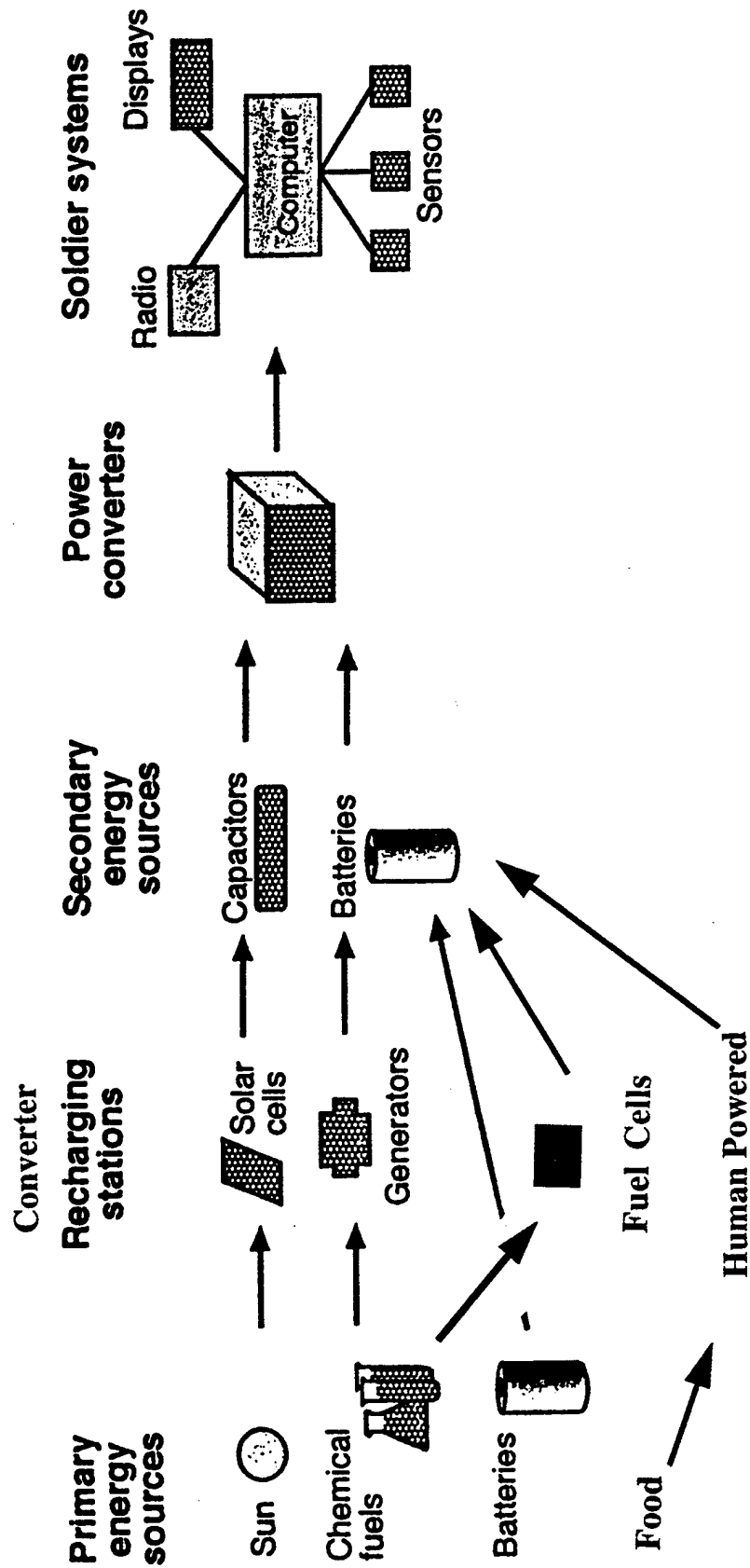

# Prospector IX - Human Powered Systems

## Workshop

Technology Summary of Energy Systems

Power System	State of the Art	Potential for Improvement	Key Issues	Scaling Laws	Impact on Dismount Soldier	Hostile Signature	Suppression Potential	Fuel Required	Autonomy Time
Primary Battery	Mature	Moderate	Energy density Safety Power density Environmental impact	Known	Longer mission Less weight Disposability	Minimal	Excellent	None	Hours/days
Secondary Battery	Mature	Moderate	Energy density Cycle life Power density	Known	New capability Cost savings Less weight	Minimal	Excellent	None	Hours
Thermophotovoltaic	Emerging	Excellent	Requires cooling Efficiency Lifetime Ruggedization	Uncertain	New capability Cost savings Longer mission	Thermal	Moderate	Multifuel	Days/weeks
Fuel Cells (Hydrogen)	Exploratory development	Excellent	Fuel Water management Safety	Known	New capability Less weight Cost savings	Thermal	Excellent	Hydrogen	Days/weeks
Fuel Cells (Methanol)	Emerging	Excellent	Fuel and fuel crossover Catalyst	Uncertain	New capability Cost savings Less weight	Thermal	Excellent	Methanol	Days/weeks
Alkali Metal Thermal to Electrical Converters	Emerging	Excellent	Liquid metal Membranes Pumps/wicks Ruggedization	Uncertain	New capability Less weight Cost Savings	Thermal	Moderate	Multifuel	Days/weeks
Nuclear Isotope	Limited	Excellent	Safety Environmental impact Cost Public acceptance	Known	New capability Autonomy	Thermal Nuclear	Moderate	Special	Month/years
Internal Combustion	Some versions mature	Moderate to excellent	Fuels Vibration Life	Uncertain	Cost savings Less weight	Thermal Acoustic	Moderate	Multifuel (Some special)	Days/weeks
Microturbine	Emerging	Excellent	Safety	Uncertain	New capability	Acoustic	Difficult	Special	Days/weeks
Thermoelectric	Some versions mature	Moderate to excellent	Efficiency Materials Coupling Conversion mechanisms	Known	New capability Less weight	Thermal	Moderate	Multifuel	Days/weeks
Human Powered	Nonexistent	Excellent		Unknown	New capability Cost saving Autonomy	Minimal	Excellent	Food	Weeks

# Prospector IX - Human Powered Systems

## Workshop

Activity	Power (W)
Sleeping	81
Standing at ease	128
Walking	163
Walking briskly	407
Long-distance running	1048
Sprinting	1630

Power Levels associated with Human Activity

Source	Maximum Power Available (W)	Estimated Conversion Efficiency
Body heat	116	~3% (assuming total capture)
Possible Harvestable Breath	1.0	40% (based on turbine efficiency)
Blood pressure	0.9	about 2%
Upper limb motion	24-60	< 3%
Walking (heel strike)	67	piezoelectric converter ~7% generator ~50%

# Prospector IX - Human Powered Systems Workshop

$$P = A \cdot C \cdot f \cdot V^2 + A \cdot I_{sw} \cdot V + A \cdot I_{leak} \cdot V$$

where

$A$  = percentage activity factor

$C$  = total chip capacitance (Farads)

$V$  = total voltage swing, usually near the power supply voltage (Volts)

$f$  = chip clock frequency (Hz)

$I_{sw}$  = short circuit switching current (Amps), current when both PMOS (p-type metal-oxide semiconductor) and NMOS (n-type metal-oxide semiconductor) are on simultaneously during a logic change

$I_{leak}$  = leakage current (Amps) from substrate injection and subthreshold effects

# Prospector IX - Human Powered Systems Workshop

## Silicon Power Reduction Best Known Methods

- Low power design best known methods
  - Circuit, logic, microarchitecture
- Advanced process and voltage scaling
  - 3.3V  $\blacklozenge$  1.8V
  - 0.5 $\mu$ m  $\blacklozenge$  0.25 $\mu$ m

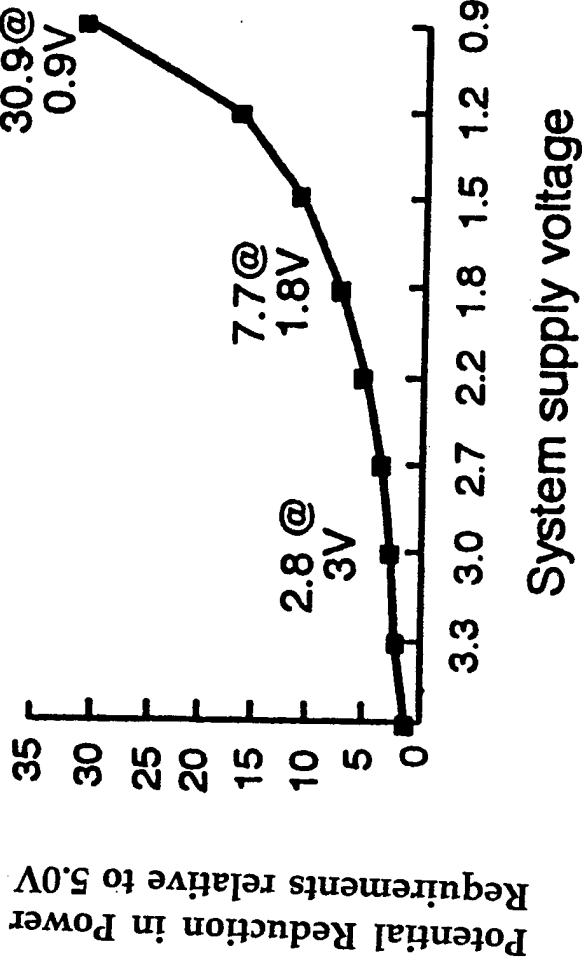

# Prospector IX - Human Powered Systems

## Workshop

Power consumed relative to 1994 technology  
(holding performance ~constant)

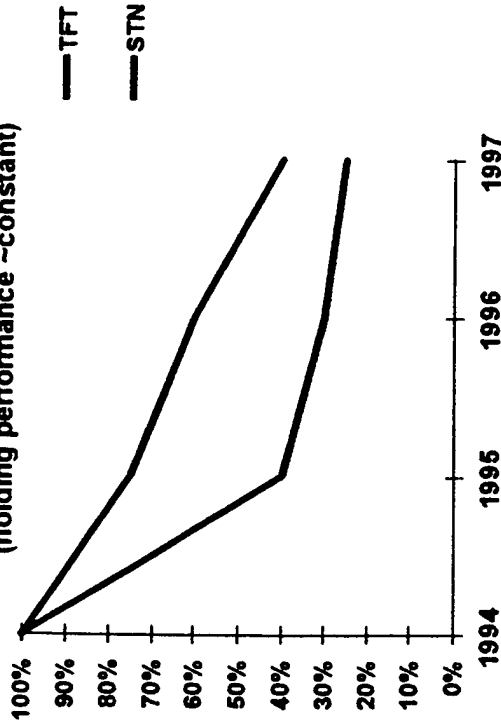

Displays

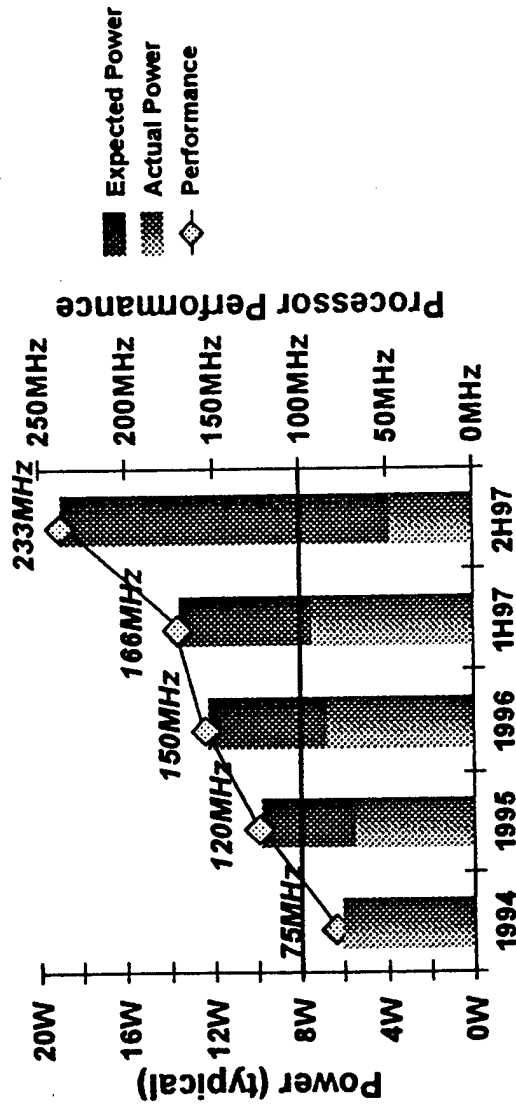

Processors

# Prospector IX - Human Powered Systems Workshop

## SPEED-POWER CHARACTERISTICS OF MICROPROCESSORS VS. TIME

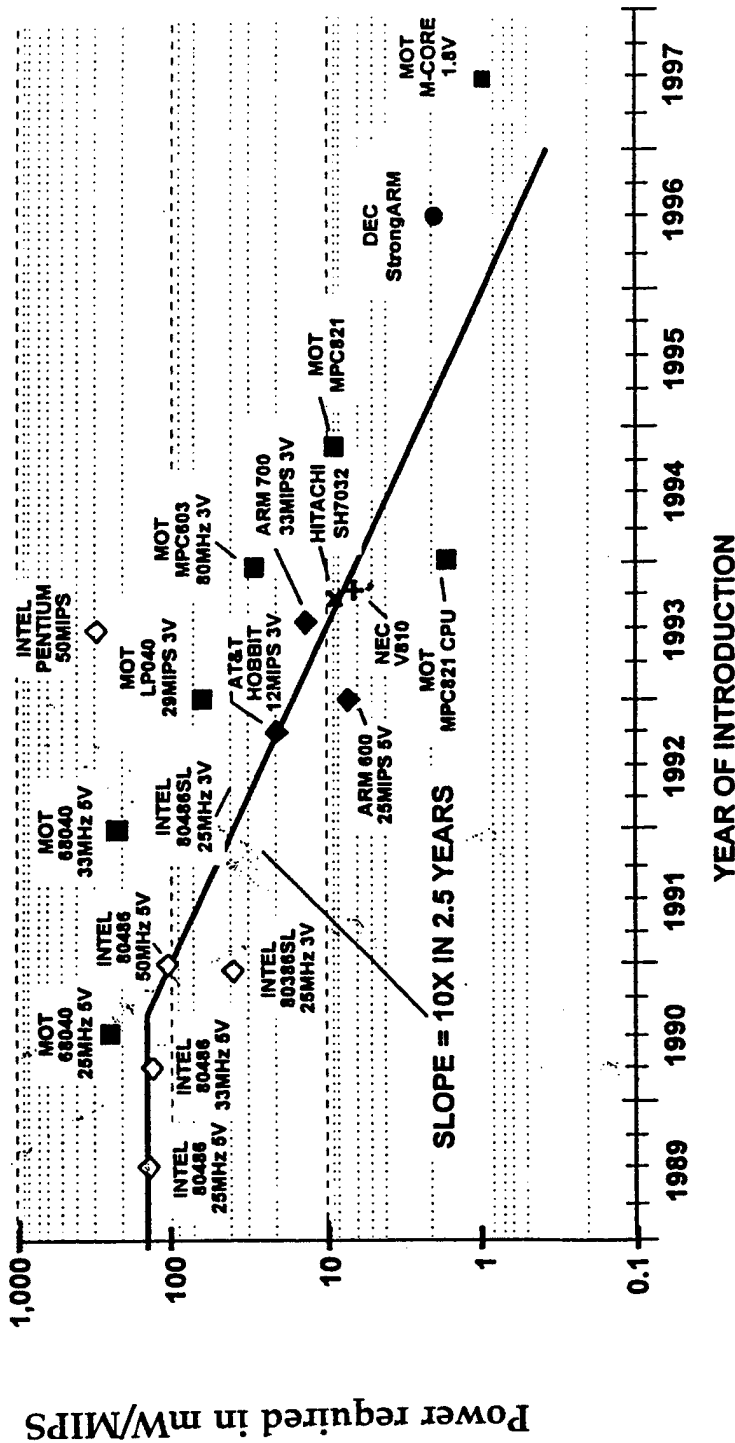

# Prospector IX - Human Powered Systems Workshop

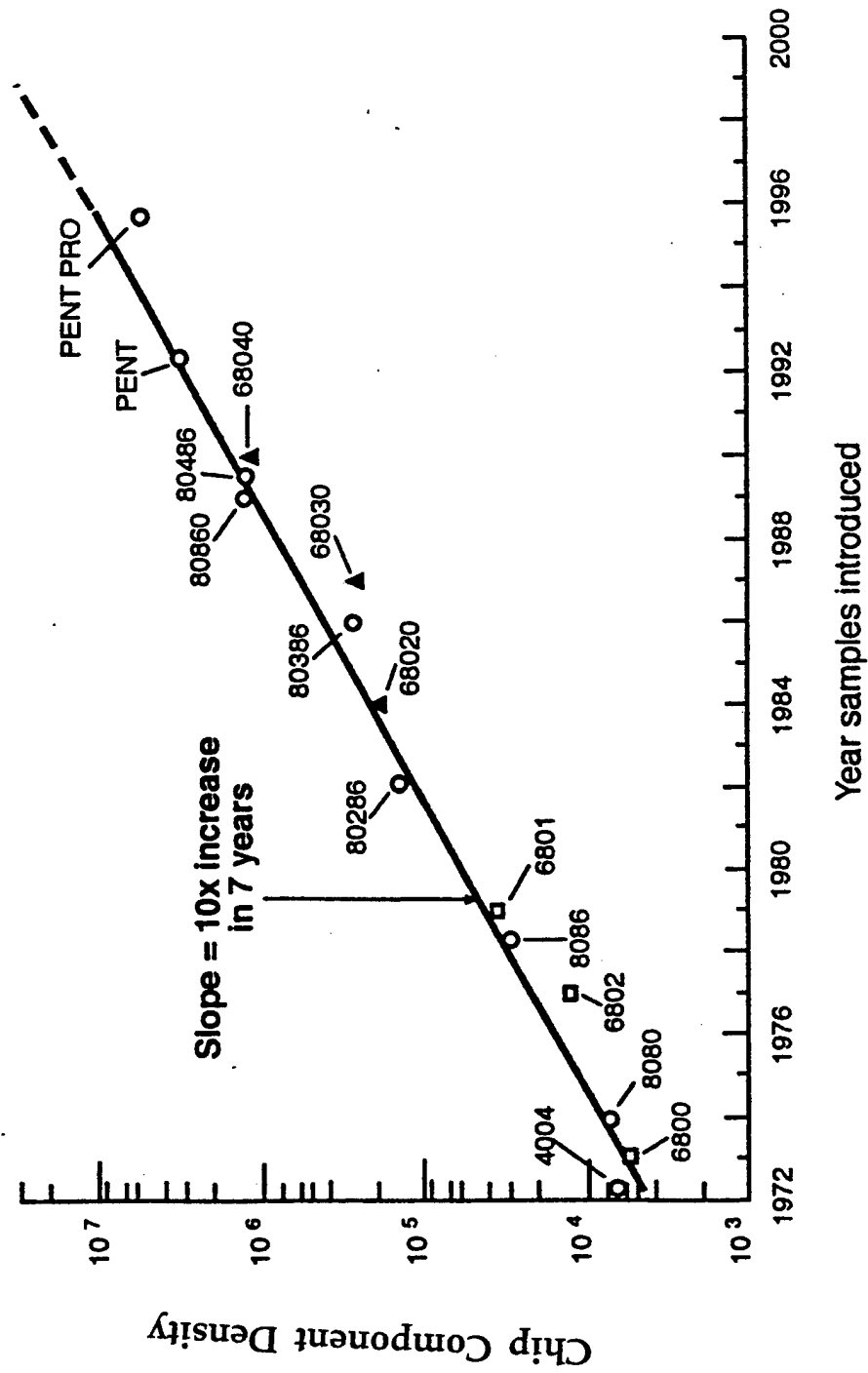

# Prospector IX - Human Powered Systems

## Workshop

### Comparison of Power Requirements for the Land Warrior System and Notional Dismounted Soldier Systems

	Land Warrior in 2001 (Operating Power in Watts)	Commercial Technology in 2001 (Operating Power in Watts)	Commercial Technology in 2015 (Operating Power in Watts)
<u>Computer/Radio Subsystem</u>			
Computer	14.800	0.150	0.010
Hand-Held Flat Panel Display	6.400	0.200	0.007
Soldier Radio			
Receive	1.400	0.100	0.025 <sup>a</sup>
Transmit	6.000	1.600	1.520 <sup>a</sup>
Squad Radio			
Receive	2.000	-- <sup>b</sup>	-- <sup>b</sup>
Transmit	12.000	-- <sup>b</sup>	-- <sup>b</sup>
Global Positioning System	1.500	0.100	0.020
Video Capture	<u>1.000</u>	<u>0.050</u>	<u>0.010</u>
Subtotal	45.100	2.200	1.592
<u>Integrated Helmet Assembly (IHAS Subsystem)</u>			
Laser Detectors	0.600	0.050	0.025
Helmet Mounted Display	4.900	0.220	0.025
Imager	< 0.100	0.050	0.025
Subtotal	5.600	0.320	0.075
<u>Weapon Subsystem</u>			
Laser Rangefinder	0.050	0.050	0.025
Laser Aiming Light	0.075	0.005	0.005
Digital Compass	0.350	0.005	0.002
Thermal Weapon Sight	<u>5.525</u>	<u>1.100</u>	<u>0.160</u>
Subtotal	6.000	1.160	0.192
Wireless Sensor and Display Interconnect	--	0.100	0.050
<b>TOTAL SYSTEM POWER</b>	<b>56.70</b>	<b>3.78</b>	<b>1.91</b>

---

---

# *Prospector IX - Human Powered Systems Workshop*

## Conclusions

Dramatic reductions in power/energy requirements are possible for Soldier

- Clever software
- Higher component density
- Lower voltage
- Clever packaging

Energy/power levels may be reduced to the point where electrical energy may be extracted from human sources for some applications

**“DARPA PERSPECTIVE ON POWER TECHNOLOGY”**

**Dr. Robert J. Nowak**

**DARPA/DSO  
Arlington, VA 22203-1714**



# DARPA PERSPECTIVE ON POWER TECHNOLOGY



Defense Sciences Office

Presented to:

Prospector IX  
Human Powered Systems  
Durham, NC

November 2-5, 1997

Bob Nowak  
DARPA/DSO  
phone: 703-696-7491  
fax: 703-696-9780  
RNOWAK@darpa.mil



# Advanced Energy Technologies



Defense Sciences Office

## Power for the Military

**Mobile Electric Power**  
2 - 100 kW

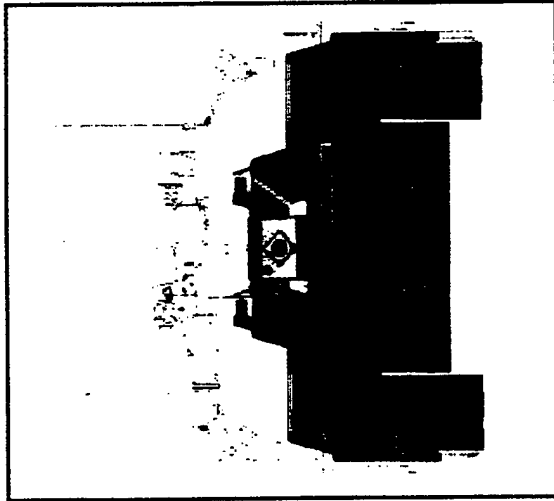

- Silent Watch
- Field Power Stations

**Portable Power**  
50 - 500 W

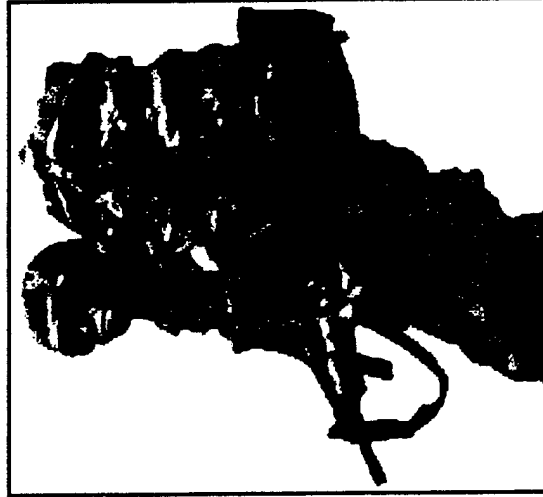

- Battery Replacement
- Micro-Climate Cooling
- Battery Charging

**Energy Harvesting**  
< 5 W

**Micro - Internetted Unattended  
Ground Sensor**



~ 1"

- Ground Sensors
- Micro - Robots



# Mobile Electric Power 2 - 100 kW Fuel Reformer Demonstrations



Defense Sciences Office

100 kW PAFC

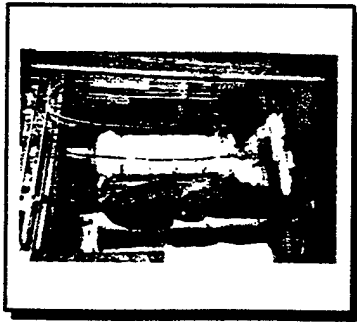

- 14 kW Tested
- 100 kW Fabrication

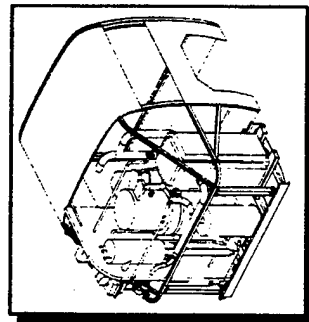

- Georgetown U. Bus

20 kW PEMFC

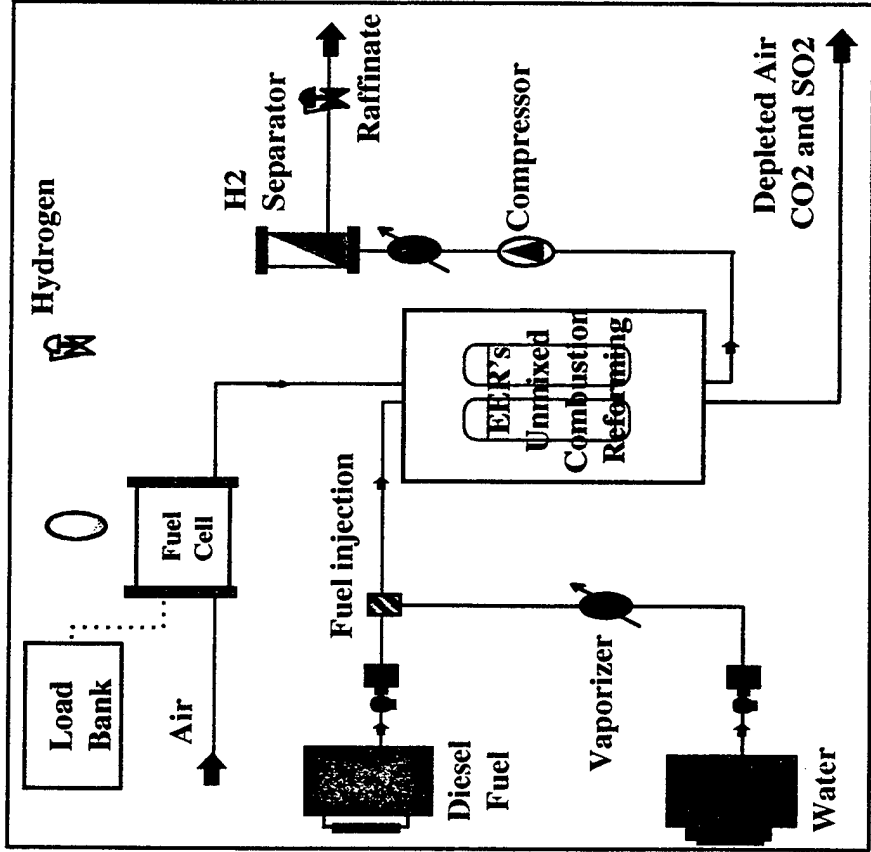

10 kW SOFC

Multipurpose Shelter

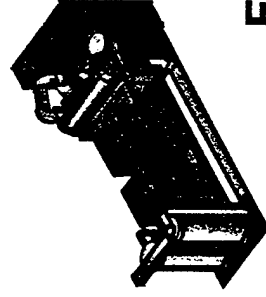
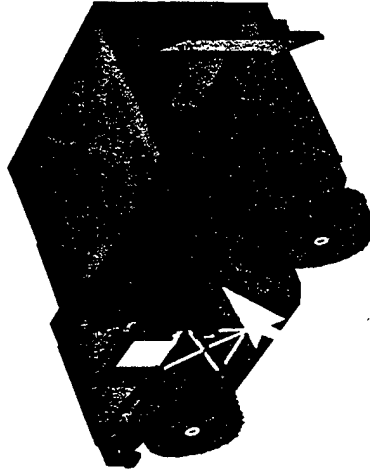

Fuel Cell



# System Mass vs. Mission Duration Mobile Electric Power - 10 kW (Logistics Fuel)



Defense Sciences Office

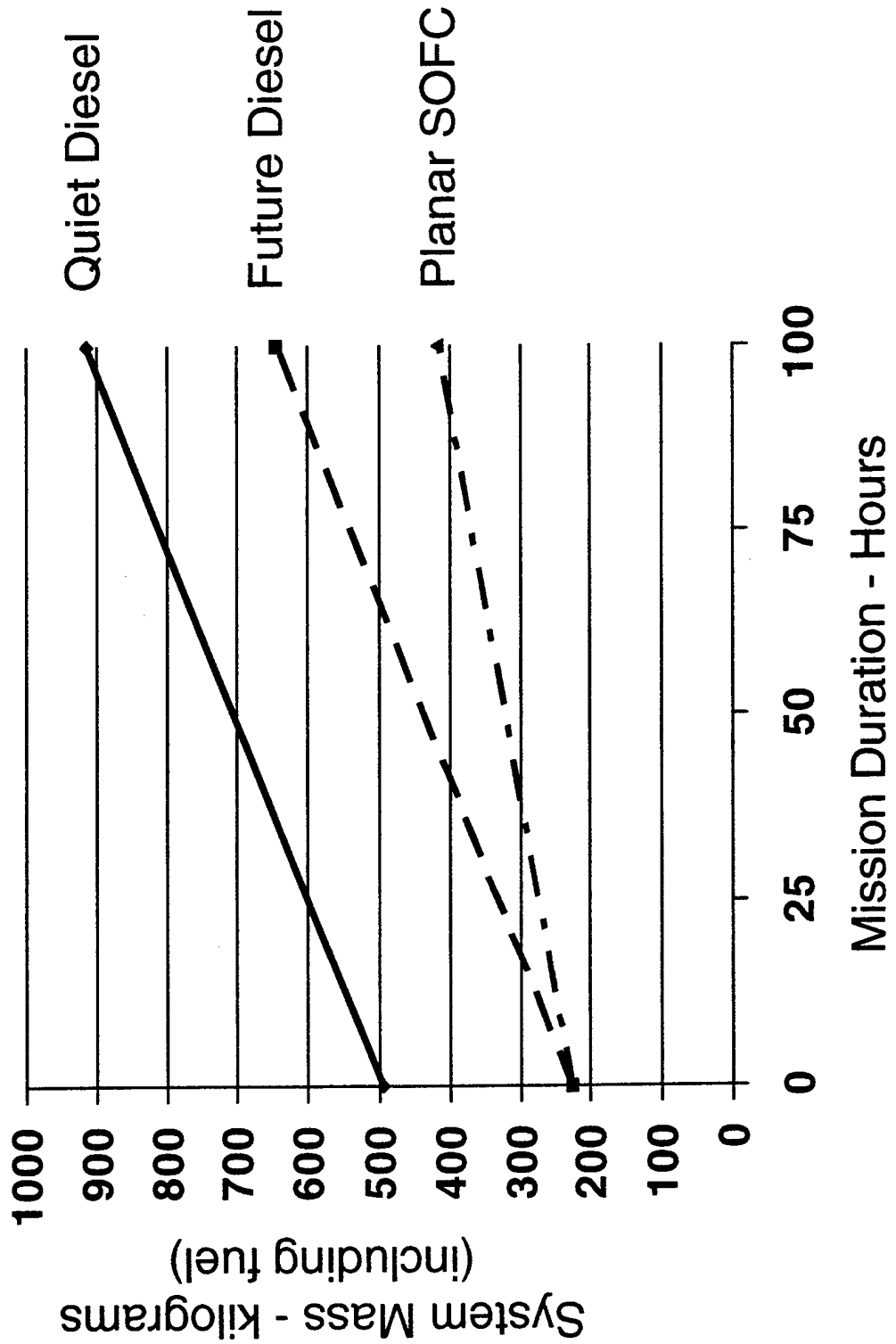



# Energy Conversion vs. Energy Storage



Defense Sciences Office

System Mass (or Volume or Cost)

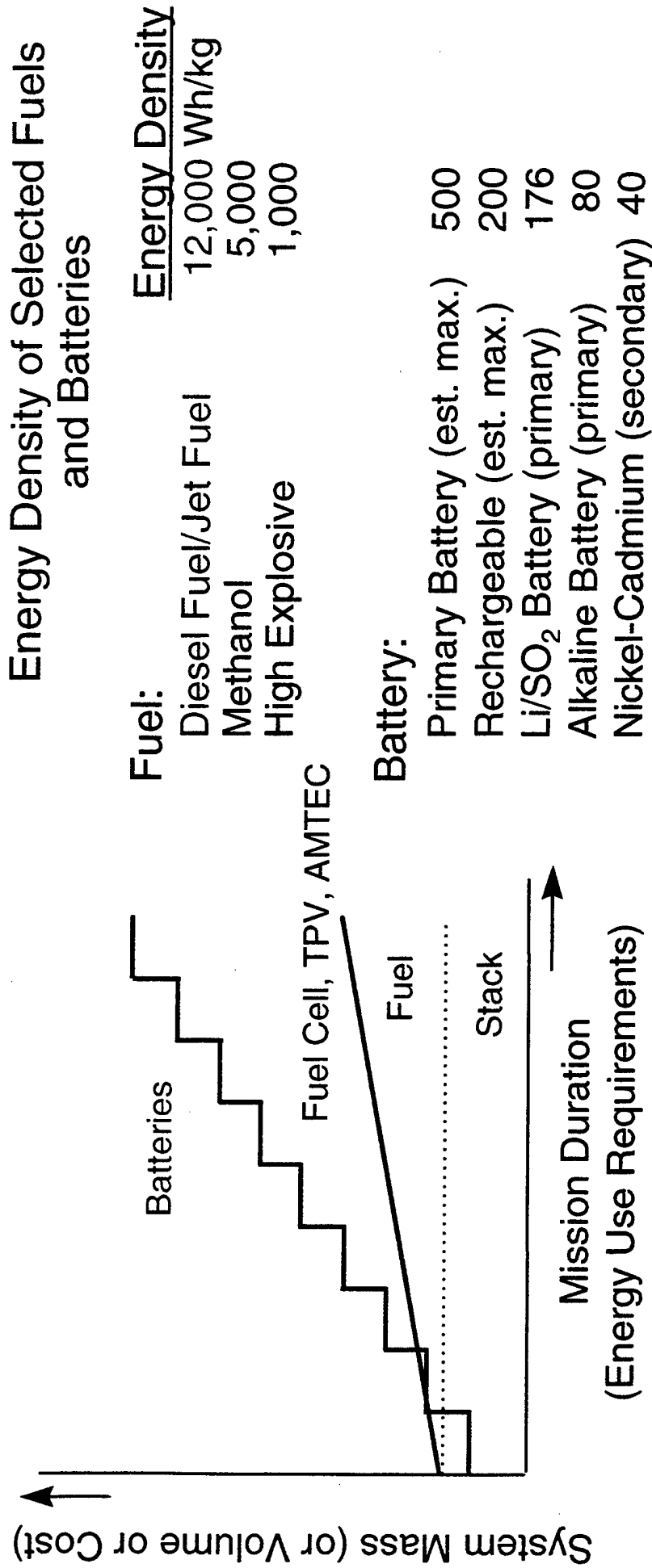

**Driving Force:** Substantially decreased size, weight, and cost with improved safety and environmental compliance → Increased force mobility





# System Mass vs. Mission Duration Portable Power - 500 W



Defense Sciences Office

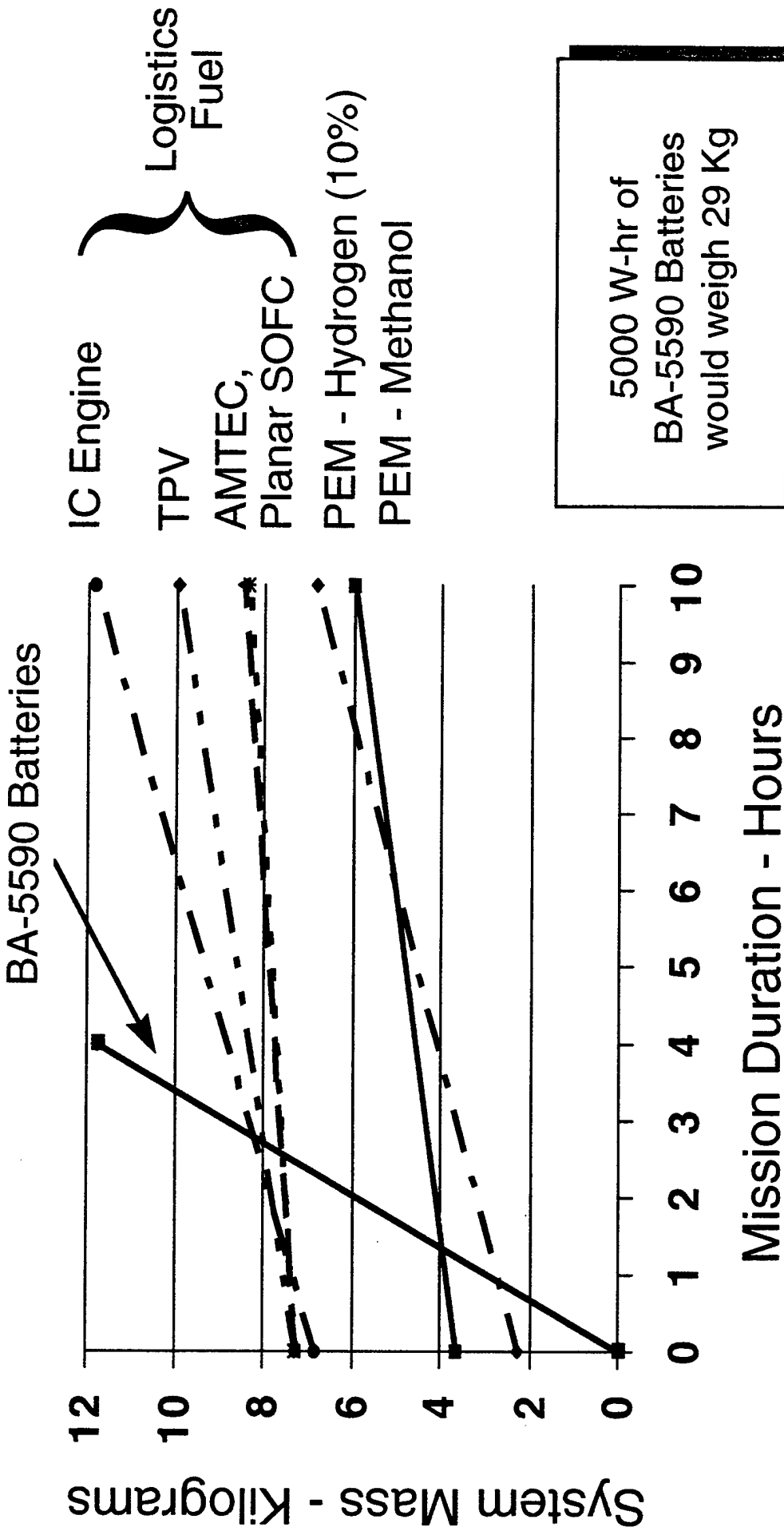



# Energy from the Environment



Defense Sciences Office

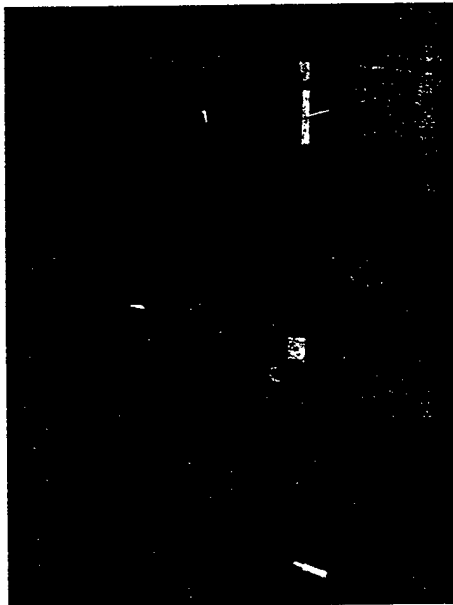

**Marine Corps  
Solar - PV; Wind  
6 kW**



**DARPA CIS  
Flexible PV  
18 W**

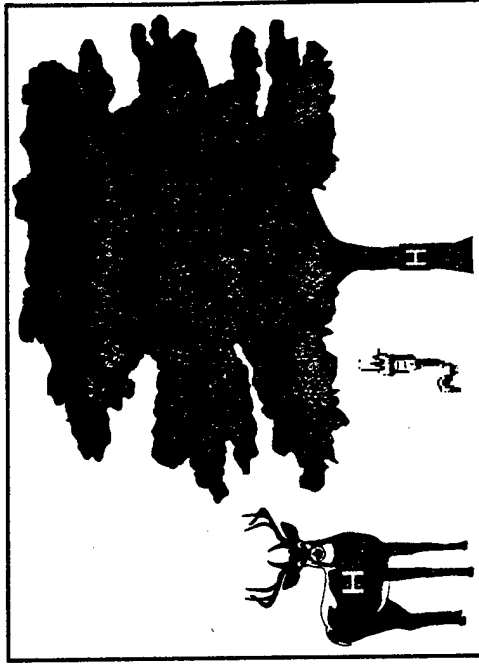

**DARPA Energy Harvesting  
Bio, Mechanical, Solar,  
Gradients, EM, Transmission  
Line, Human Activity, etc.  
< 5 W**



# Energy Harvesting - Possible Sources



Defense Sciences Office



Heel Strike 1 - 5 W

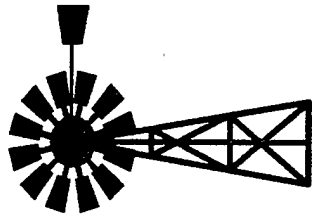

Small Wind Turbines  
18 - 500 W

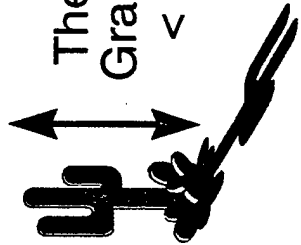

Thermal Gradients  
< 1 W



Transmission Line  
10 W - 3 kW

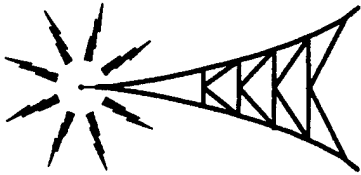

AM, FM  
10 mW/10<sup>4</sup>m<sup>2</sup>

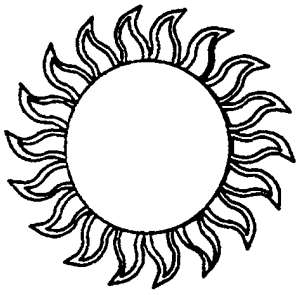

Solar  
1 kW/m<sup>2</sup>



Wave Action, Ocean Currents  
5 - 10 W

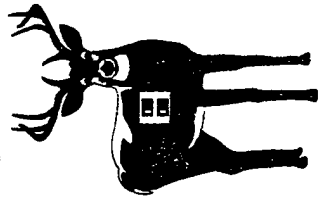

Thermal, Chemical Gradients  
< 1 W

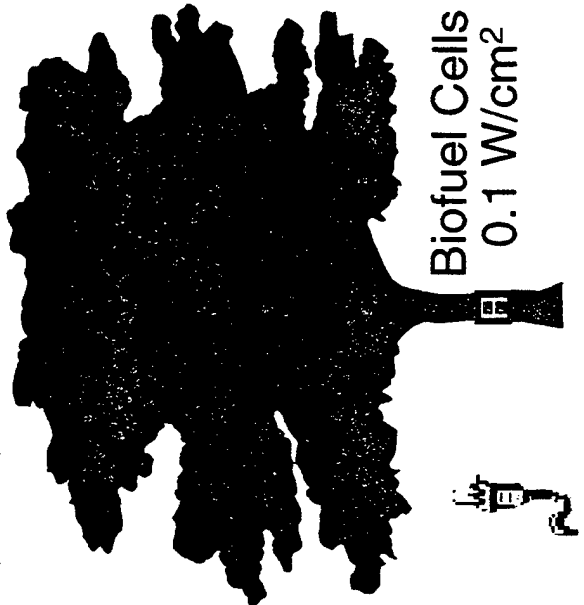

Biofuel Cells  
0.1 W/cm<sup>2</sup>



# Energy Harvesting: A Commercial Example



Defense Sciences Office

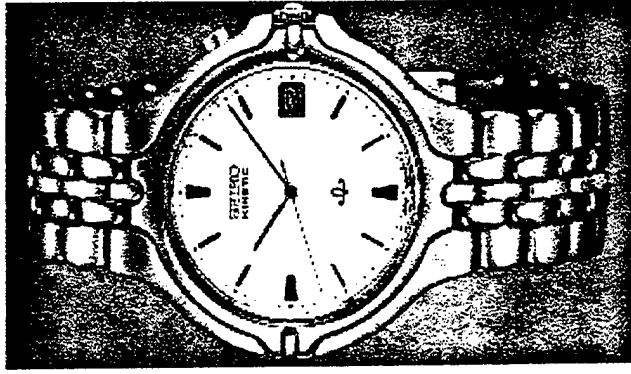
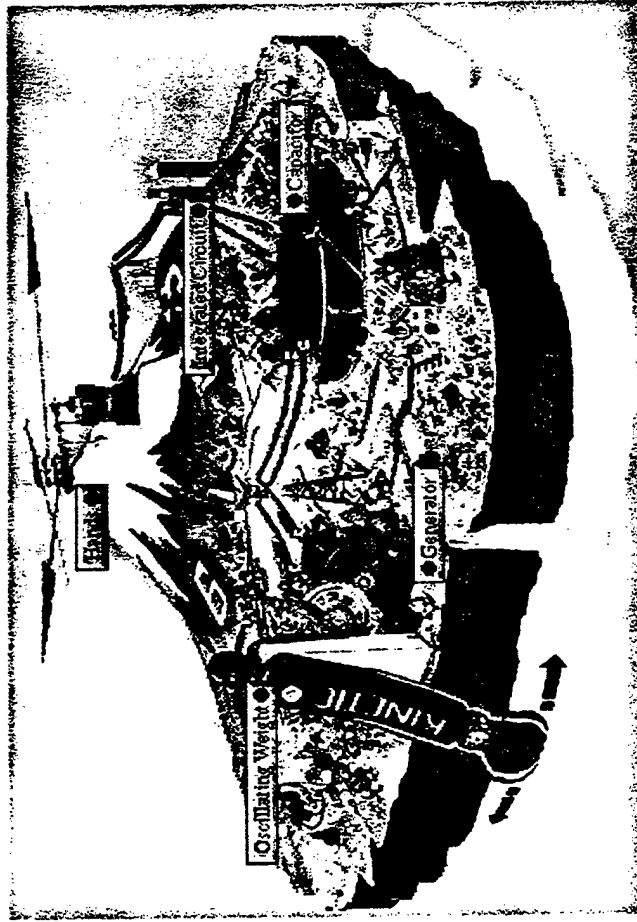

- Keys to success
- Mechanical-to-electrical conversion
  - Efficient energy storage
  - Low power application



# Energy Harvesting - Opportunities



Defense Sciences Office

- Harvesting Concepts - On and Off the Soldier
- Compatible Storage and Conditioning
- Power Management vs. Duty Cycle
- Materials/Fuels Processing
- Size, Weight (Footprint)

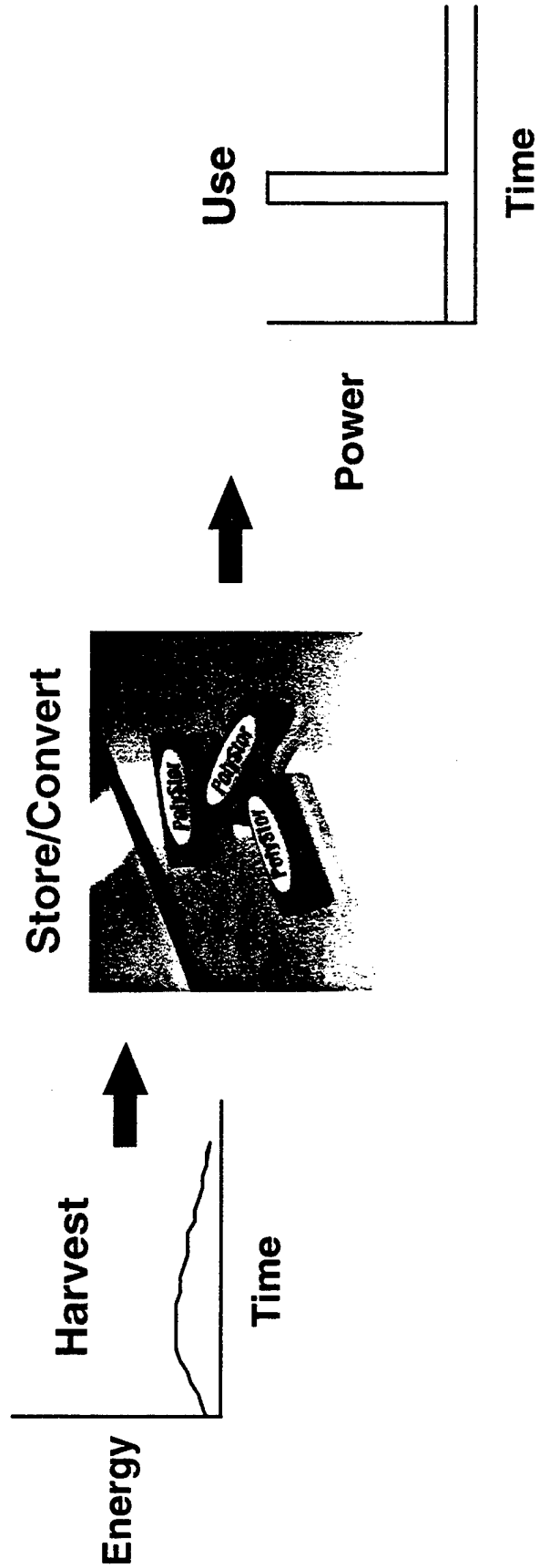

**“SPECIAL OPERATIONS PERSPECTIVE”**

**Mr. Sal C. Raineri  
Ft. Bragg, NC 28307**

**SOF OPERATES AT LONG RANGE FROM FRIENDLYS AND ONCE INSERTED  
DO NOT RECEIVE RESUPPLY.**

**EACH SOF TEAM MEMBER MUST CARRY ALL EQUIPMENT TO INCLUDE FOOD  
FOR THE DURATION OF THE MISSION.**

**[WHATEVER YOU CARRY IN YOU CARRY OUT]**

SOF MISSIONS: RANGE FROM HOURS -- MONTHS

SPECIAL RECONNAISSANCE -- 21 DAYS  
D.A. -- HOURS TO DAYS  
U.W. -- LONG TERM  
OOTW -- LONG TERM  
LIE -- LONG TERM  
URBAN -- TERRAIN DEPENDENT

(IN ALL CLIMATIC & TEMPERATURE ENVIRONMENTS)

METHOD OF INFILTRATION

PARACHUTE -- STATIC / HALO / HAHO  
AIR / LAND (AIRCRAFT)  
SWIM SURFACE / SUB-SURFACE  
WALK (CLIMB)  
WATER DELIVERY  
TAKE THE YELLOW / RED BUS

EQUIPMENT REQUIRING POWER SOURCES

RADIOS -- 2-3 ONE BEING SURVIVAL (EACH)

NVD

GPS

OTPICS -- WPNS / HAND HELD

LASER -- ID AND DESIGNATOR / TGT ACQUISITION

SENSORS: SEISMIC / ACOUSTIC / NEAR-FAR IR (THERMAL)

HAND HELD RADAR LOCATOR AND LASER UTILIZATION

SIGNATURE REDUCTION: \_\_\_\_\_ ★

WEARABLE COMPUTER

• VOICE TRANSLATOR

FLASH & STROBE LIGHTS (WHITE / IR)

UNDER WATER PROPULSION

• ROBOTICS SYSTEMS

**EQUIPMENT LOADS**

**AVERAGE RUCK SACK -- 115-140 LBS**

**VESTS / LBE & WPNS -- 50-65 LBS**

**POWER GENERATION SYSTEMS**

**BATTERIES**

**SOLAR**

**HAND CRANK GENERATOR (FOOT POWERED)**

**(EACH SOF TEAM MEMBER CURRENTLY CARRIES THREE TIMES NEEDED  
SUPPLY OF BATTERIES)**

**(PIEZOELECTRIC FOOT POWERED SYSTEM LOS ALAMOS)**

**SOLVE POWER GENERATION FOR THE MOST DEMANDING AND DIFFICULT**

**S.O.F.**

**YOU SOLVE FOR THE REST OF SERVICES & LAW ENFORCEMENT.**

**OVERVIEW SESSION 2**

**“SUO POWER PROFILES - CECOM PERSPECTIVE”**

**Mr. James E. Stephens**

**CECOM  
Front Royal, VA 22630**

SMALL UNIT OPERATIONS  
POWER PROFILES - CECOM PERSPECTIVE

PRESENTED TO PROSPECTOR IX WORKSHOP

NOVEMBER 2, 1997

JAMES STEPHENS  
US ARMY CECOM

(703) 704-2006

[jstephens@belvoir.army.mil](mailto:jstephens@belvoir.army.mil)

# THE POWER SPECTRUM

PORTABLE

< 500 WATTS

GRAY AREA

MOBILE POWER

> 500 WATTS TO 1.1 MW

- BATTERY DOMAIN
  - TOO HEAVY
  - TOO COSTLY
- EXPLORING ALTERNATE TECHNOLOGY
  - NICHES FIRST
  - GENERAL USE LATER
- HYDROGEN SUPPLY KEY TO FUEL CELL SUCCESS
- MUST COMPETE WELL WITH OR AUGMENT BATT.

- DIESEL / TURBINE POWERED GENERATORS
- COMPETITORS MUST USE DIESEL FUEL

“Power Revolution a Necessity”

“New Sources of Battlefield Energy Would Have Revolutionary Consequences”

Source: ARMY AFTER NEXT “EMERGING STRATEGY”

DEPUTY CHIEF OF STAFF FOR DOCTRINE, TRADOC



# Individual Warfighter System Size, Weight, and Power

- **Soldier Mounted**
- **< 1 kg**
- **< 5 watts**
- **No keyboard**
- **Very user friendly interface**
- **Single battery**
- **Minimal wires**
- **Plug and play for different applications**
- **Physically robust**

**SMALL UNIT OPERATIONS - POWER  
REQUIREMENT SUMMARY**

- **AVERAGE POWER DEMAND - 5 WATTS**
- **PEAK POWER DEMAND - 20 WATTS**
- **MISSION LENGTH - 7 DAYS**
- **MISSION DAY PROFILE**
  - **20 HOURS ON**
  - **4 HOURS OFF**
- **TOTAL ENERGY DEMAND - 700 WHRS**

WHO'S THE ENEMY!!!

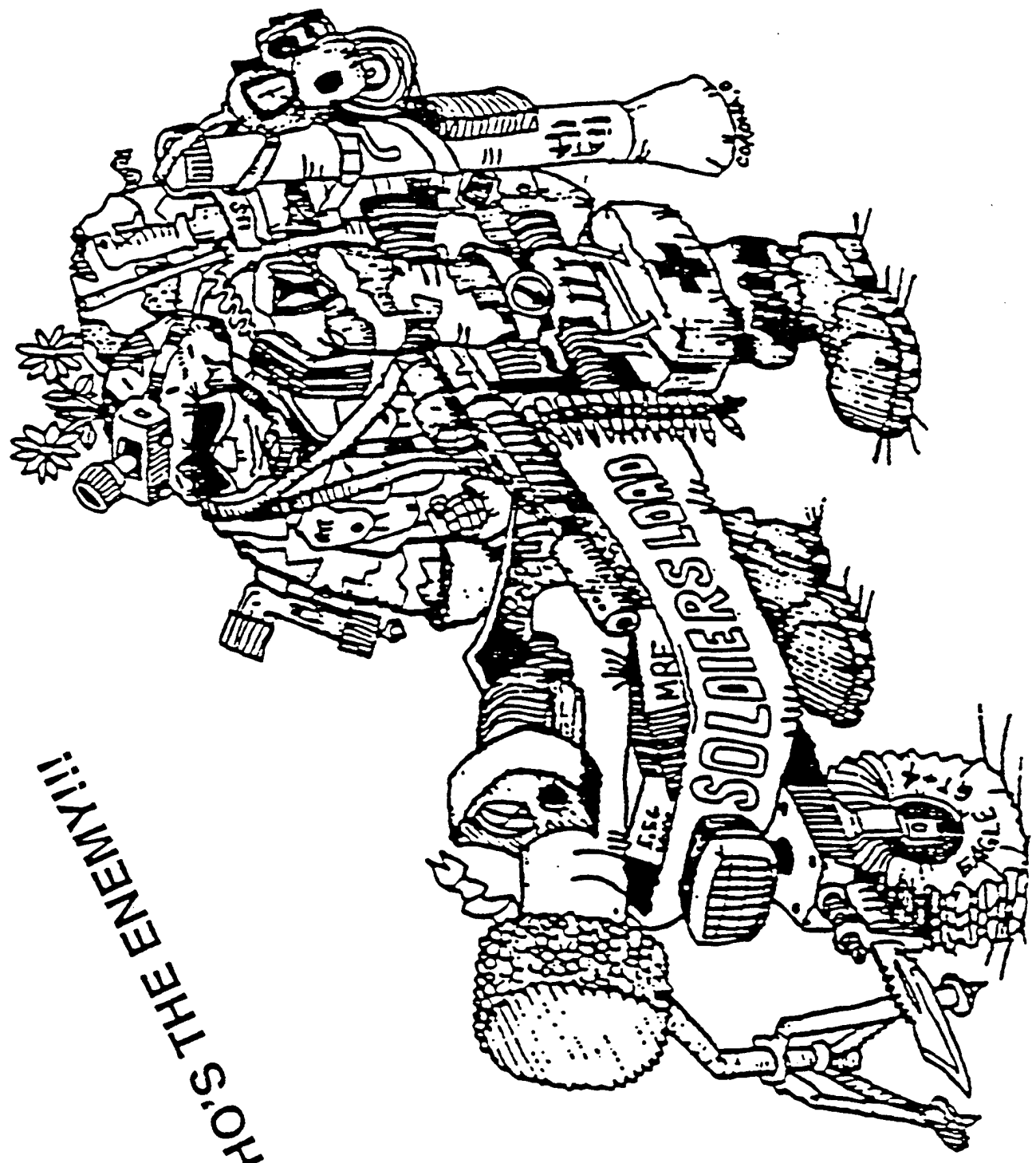



## REQUIREMENTS: SYNOPSIS

- FEATURES CRITICAL TO SO SOLDIERS: SMALL, LIGHT, CHARGE INDICATOR AND RECHARGEABLE
- INCREASE POWER DENSITY/MAINTAIN COST
- EQUIPMENT LIMITATIONS CAN NOT DICTATE MISSION PLANNING/ ACCOMPLISHMENT
- LIGHTWEIGHT POWER IS AN ALL-OPERATIONS PROBLEM: WAR, OOTW/PEACEKEEPING, AND TRAINING
- POWER SOURCES REQUIREMENTS ARE NOT SOF-UNIQUE, THUS LEVERAGING NEEDED
- LIGHTWEIGHT POWER IS 3RD HIGHEST TECHNOLOGY PRIORITY OF CINCSOC

**DISMOUNTED / REMOTE SENSOR SUITES  
POWER REQUIREMENTS SUMMARY**

- **POWER REQUIRED <1 - 100 WATTS**
- **VERY HIGH PEAK POWER TO AVERAGE  
(1500 TO 1)**
- **240 WHRS - 30 KWHRS**
- **MISSION DURATION - 7 TO 90 DAYS**
- **UNATTENDED MISSIONS**
- **SOME MISSIONS ARE EMPLOY AND FORGET**
- **DEPLOYED FROM AIR OR MANUALLY**



## Soldier Power System Requirements

*Small, light weight, soldier portable*  
Continuous power for extended periods  
Necessary power for standard and future equipment  
*Undetectable*: silent, odorless, easily concealed  
*Safe*: stable materials, less hazardous  
Easily supported, maintained  
Durable, rugged, NBC *survivable*  
Modular, interconnective capability  
Operate under all conditions: ECM, smoke, aerosols, fog, rain, haze, dust,  
wind, snow, icing, NBC, heat, cold, etc.....  
Compatible with full protective posture  
Decontaminable w/o efficiency loss



(Source: MNS for Soldier Power System)

**Dismounted Battlespace Battle Lab**

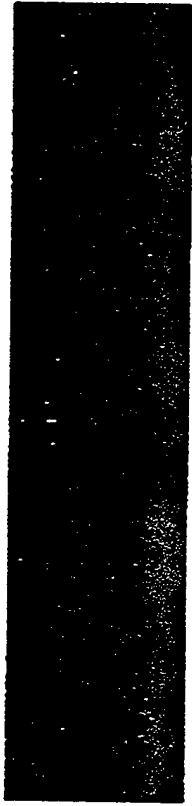

- MISSION CANNOT BE CONSTRAINED BECAUSE OF POWER LIMITATIONS (PERFORMANCE)
- SOLDIER MOBILITY MUST NOT BE HAMPERED (WEIGHT)
- UNITS MUST BE ABLE TO TRAIN AS THEY FIGHT (COST)
- SOLDIERS MUST HAVE SAFE POWER (SAFETY)

122



**POWER...**  
**WHEN WE NEED IT...**  
**WHERE WE NEED IT!!**

SUMMARY OF POWER / ENERGY PROFILES  
FOR VARIOUS INDIVIDUAL SOLDIER MISSIONS

<u>APPLICATION</u>	<u>POWER (WATTS)</u>	<u>ENERGY (WHRS)</u>	<u>COMMENT</u>
SPECIAL OPS	50	2500 - 30,000	SOME SET/FORGET MISSIONS.
SMALL UNIT OPERATIONS	5 / (25 PEAK)	700	LIGHTWEIGHT
SENSOR SUITES	5 / 50 / 100	240 - 30,000	LONG MISSIONS
SOLDIER POWER	50 / 150	1200 - 2,500	MUST AUGMENT BATTERIES

## **POWER MANAGEMENT DEFINITION**

*Improve the warfighter's capabilities by  
lightening his load and lessening the logistics  
burden by:*

- 1) managing power usage on the battlefield*
- 2) using advanced power generation*
- 3) reducing equipment power consumption.*

# INCENTIVES FOR POWER MANAGEMENT



## CONSERVE ENERGY IN MANPORTABLE EQUIPMENT

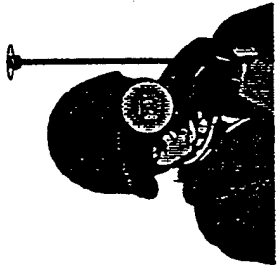

- Lighten soldier load (sustainment)
- Longer mission times
- Enhanced functional capability
- Simplified battery replacement/disposal



## OPTIMIZE VEHICULAR PLATFORMS

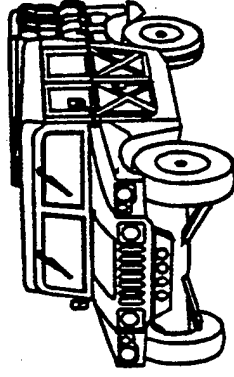

- Electronics require less volume
- Smaller generator required
- Smaller air conditioner
- Greater capability and reliability in smaller system weight/volume
- Silent Operations

**REDUCE O & S COSTS**

# **KEY PATHWAYS FOR POWER REDUCTION**

- **Low Power Electronics (i.e. low operating voltage)**
- **Smart Electronic Sub System Management (i.e: Sleep modes)**
- **System Optimization (i.e: antenna requirements, display requirements)**



# LOW POWER ELECTRONICS

$$P = C V^2 f$$

(Dynamic Power)

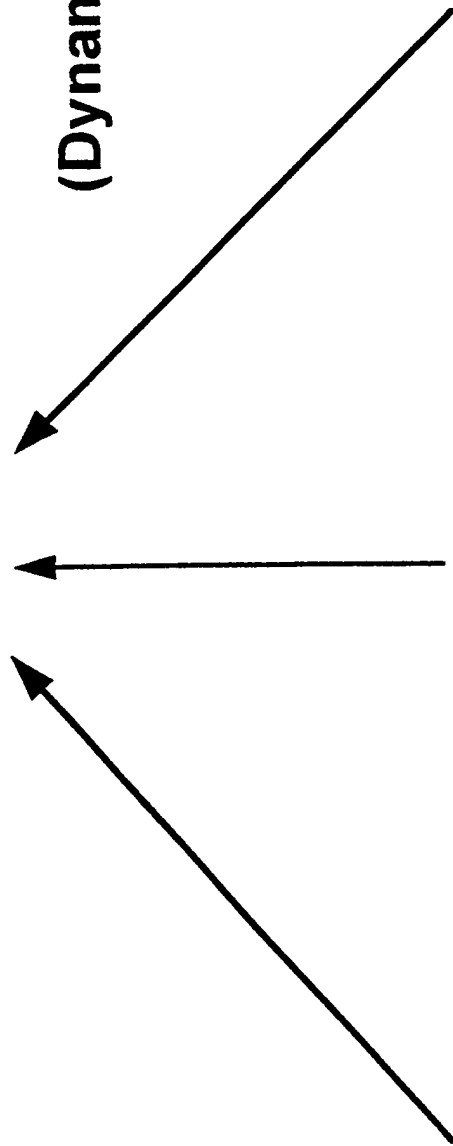

Load  
Capacitance

Supply  
Voltage

Operating  
Frequency

# POWER DEMAND AND POWER SUPPLY

	Army After Next		
Front End Power Analysis of Individual Soldier	Task Force XXI	Landwarrior	Small Unit operations
	1995	2000	2005
<b>Power Demand</b>	50 Watts 1200 Whrs 2-3 Day Missions ( Digital Equip Operates @ 5.0 volts)	25 Watts 1000 Whrs 3 + Day Missions ( Digital Equip Operates @ 3.3 volts)	5 Watts (averg) 25 Watts (peak) 700 Whrs Extended Missions - >7 days ( Digital Equip Operates @ 0.9 volts)
<b>Power Supply</b>	Primary Batteries (170 Whr/Kg)	Primary Batteries & Rechargeable Batteries BB390A/U - 96 Whr, 1.75 Kg BB2847/U - 25 Whs, .38Kg Hybrids	Batteries/ Robust Hybrids
<b>Example</b> .1 m <sup>2</sup> Solar Panel @ 19 Watts	38% of Mission	76% of Mission	380% of Mission

# POWER DEMAND AND POWER SUPPLY (Cont.)

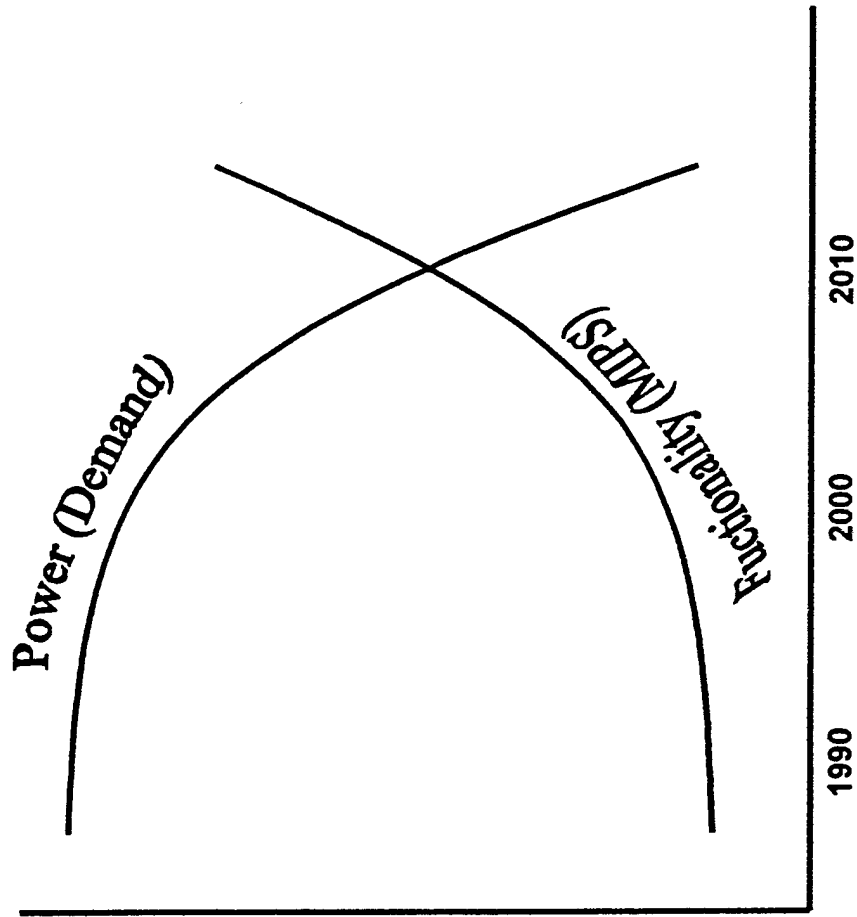

- ★ Mission length will not be constrained by power supply
- ★ Functionality will increase while power demand drops dramatically
- ★ Indigenous / Reliable Power Sources can be tapped to supply much (perhaps all) of power budget.
- ★ Robust Power Supply Hybrids needed to orchestrate:
  - ▣ Battery Charging
  - ▣ Energy Management
  - ▣ Power Distribution



**“NASA INVESTMENT IN SPACECRAFT SYSTEMS  
TECHNOLOGY”**

**Mr. Ronald J. Sovie**

**NASA Lewis Research Center  
Cleveland, OH 44135**

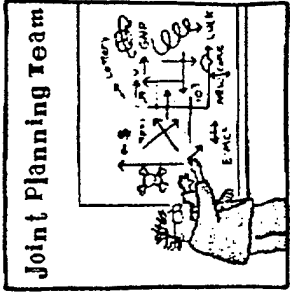

# The NASA Spacecraft Systems Technology Program

R. J. Sovie  
NASA Lewis Research Center

November 3, 1997

RJS98-001.1



## What We Will Discuss

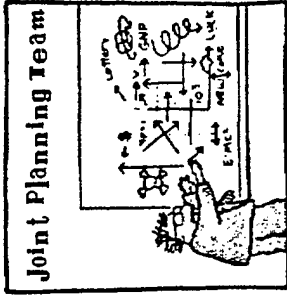

- **Spacecraft Systems Technology Program Elements**
  - Content
  - Milestones
  - Budget
- **Specific Technologies**
  - Relevant
- **Concluding Remarks**



## Spacecraft Systems Technology Program

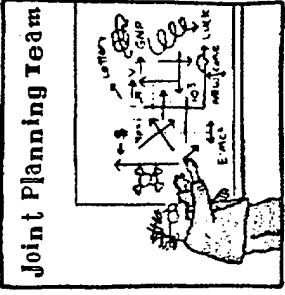

- Broad-based technology program that supports:
  - Planetary Missions
  - Mission to Planet Earth
  - Human Exploration
    - ISS
    - Shuttle
    - Lunar-Mars
    - Suits
  - Aeronautics
  - Commercial Communication
  - DOD
- Cross-Cutting Spacecraft Systems Budget
  - ~ \$40M/year ↓

# Cross-Cutting Technology Areas to Respond to Customer Technology Product Requirements

---

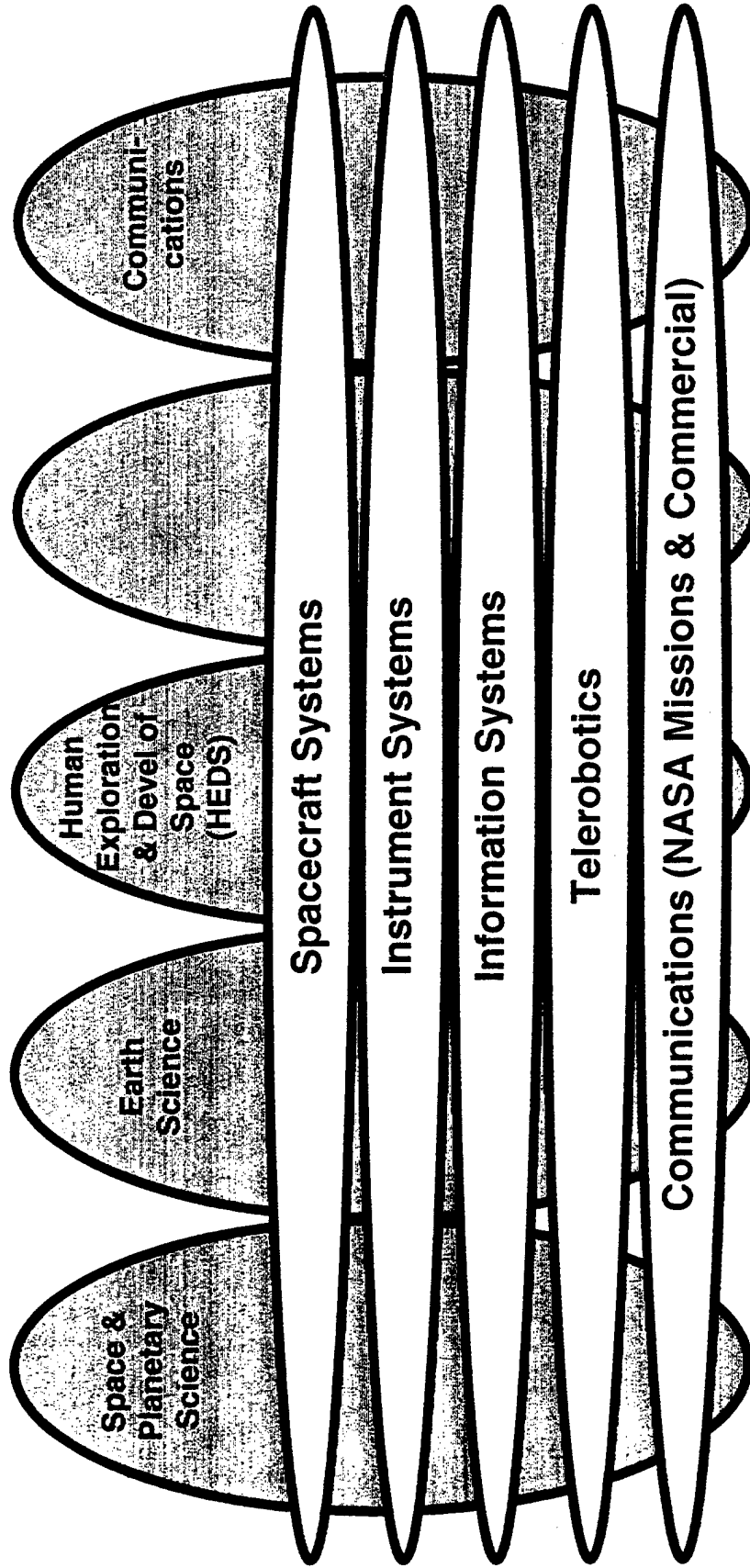

**Note:** Spacecraft Systems includes: Space Environment & Effects; Structures & Materials; Thermal Management; Power & Propulsion; Avionics; Design Tools

# Spacecraft Systems Contains 4 Disciplines & Are Managed Using Integrated Product Development (IPD) Teams

## Spacecraft Systems Joint Planning Team

### IPD Team 1:

- Power Generation, Management, & Distribution
- Power Storage & Reliability
- Thermal Control
- On-Board Propulsion

### IPD Team 3:

- Design & Simulation Tools
- Collaborative Design Infrastructure
- Microspacecraft Testbed

### IPD Team 2:

- Light Weight & Multi-Functional Structural Systems
- Breakthrough Materials
- Deployable & Inflatable Structures
- Structural Dynamics & Geometry Control
- Space Environments & Effects

### IPD Team 4:

- Systems & Advanced Architectures
- Instrument & Flight System Computing
- Guidance, Navigation, & Control
- Data Handling & Storage
- Packaging
- Low Power Electronics

# Technology Readiness Levels for Technology Products

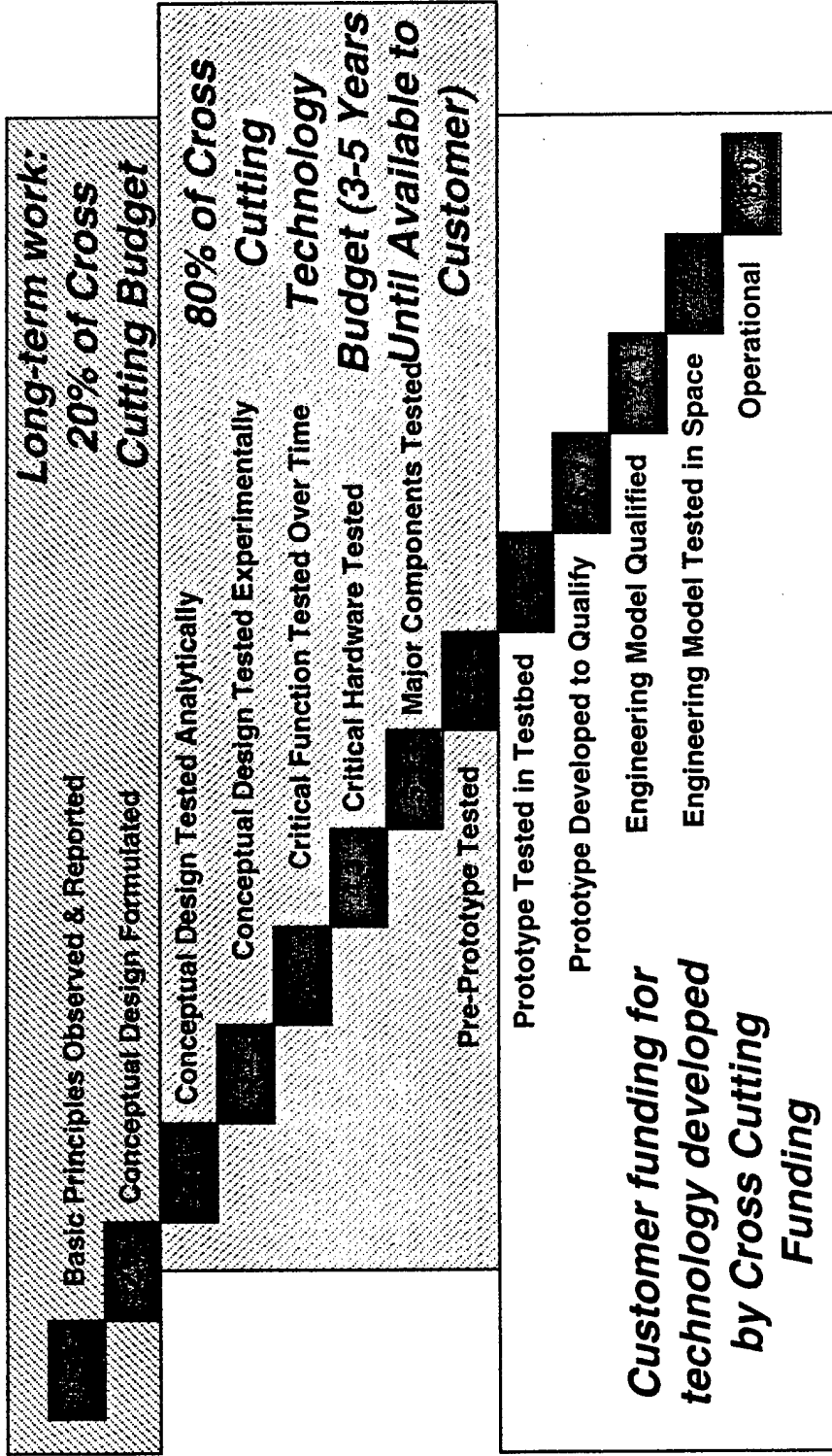

# Spacecraft Systems

95 96 97 98 99 01 05

## Mission

COMMERCIAL (COMMUNICATIONS =>  
 REMOTE SENSING => MARS SURVEYOR => SIRTF ASEP => TOPS  
 SSTI => "DISCOVERY SERIES" =>  
 NEW MILLENNIUM =>

## Power Systems

High Cycle Life Batteries for LEO (2X Whr/kg)  
 Li Batteries (Small S/C Compact Batteries & Planetary Appl) (1/2 Vol)  
 HI-Efficiency, Low Cost PV Arrays (1/2 Area, 1/2 Wt, 1/3 Cost)  
 Wide Temp. Solid State Power Electronic (-10°K to ~500°K)  
 HI-Temp for Compact Power Systems Lo-Temp. for Deep Space Ops (10X Increase in W/cm<sup>2</sup>)  
 Adv. Low Vibration Refrig. Freezer Hi-Efficiency Radioisotope

Integrated Power & Electric Propulsion

1/3 Weight  
 1/3 Size  
 1/3 Cost  
 3X Life

## On-Board Propulsion

Adv. Hi Isp Chemical Prop. for Large Delta V  
 Low Cost, "Clean" Monoprop for Small S/C Orbit Insertion & Control  
 Electric Propulsion for Small Size. LI. WL.  
 Low Power Micro-elec. <.001 lbf for Vernier Control Primary Electric Prop

100X Faster  
 10X Smaller  
 Autonomous Ops.

## Avionics

Fault Tolerant, Self Repairing Architecture Fully Modular "Tailorable" Des  
 On-Board Autonomous Navigation - Rendezvous & Landing  
 On-Board "Health Management"  
 Miniature (MEMS) Components  
 Hi-Speed Lt. Wt. Low Power Flt. Computer (GFlops. TBytes)  
 "Computer on Chip" Multiprocessor Distrib Sys Optical Data System

1/4 Cost Due to Structural Behavior & Space Environment

## Structures, Materials, & Space Environmental Effects

Control Structure Interaction  
 Jitter Suppression Precision Pointing  
 Reliable Inflatable/Deployable Structures/Mechas  
 Integrated Design Methods for Small S/C - Reduced Space Environmental Effects  
 Accelerated Materials/Structures Qualification

# Structural Dynamics & Geometry Control

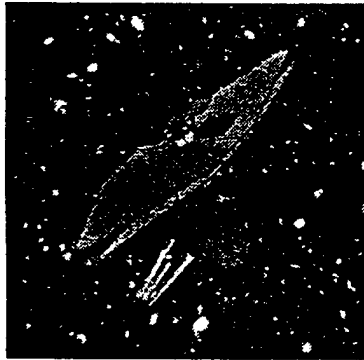

**Next Generation  
Space  
Telescope**

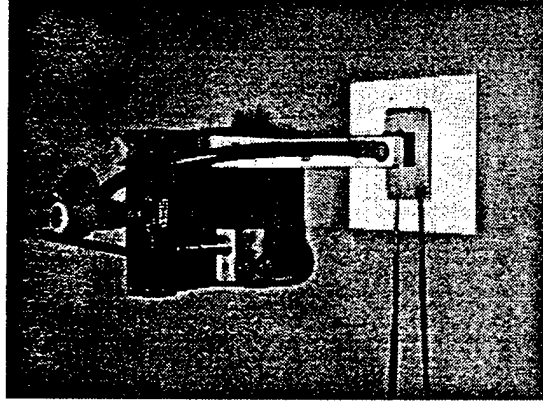

**THUNDER Long-  
Stroke Actuator**

**Objectives:**

- Cryogenic and high temperature actuator capability
- 10x improved dynamic actuator life and efficiency
- Efficient, affordable long-stroke actuators for instrument scanning, optical positioning, interferometer delay lines

**Approach:**

- Develop efficient motorless actuators for positioning and motion suppression in extreme environments
- Develop system level methods for vibration suppression and precision pointing when using flexible components
- Validate on focus testbeds

**Applications for Future Space Missions:**

Low-cost, lightweight structures with integrated efficient actuation and controls for on-orbit correction of geometry errors and changes and suppression of dynamic response

**Applications for Ground:**

Smart structures that adapt to changing environmental conditions for aircraft, buildings, bridges

**Deliverables & Schedule:**

- Complete characterization of THUNDER & Rainbow actuator concepts Q2 98
- Demonstrate cryogenic position-hold actuators Q1 99

# Deployable & Inflatable Structures

## LIDAR Photon Collector

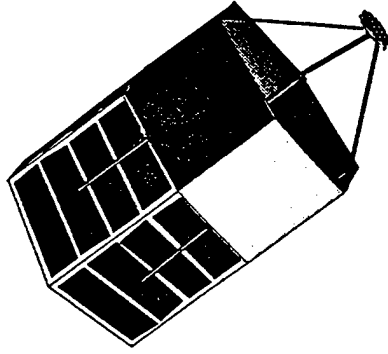

Telescope packaged

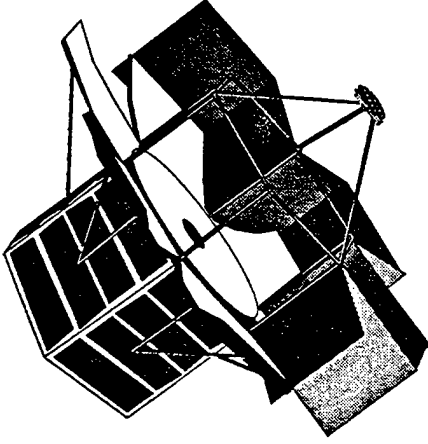

Telescope deployed  
(sun shroud partially removed)

### Objectives:

Precision deployable structures for large apertures to achieve 10X reduction in launch volume, > SOA performance

### Approach:

- Develop deployable 2.5 m photon collector, 50 kg mass, 1.4 m<sup>3</sup> stowed volume (LIDAR focus)
- Develop inflatable electromagnetic wave guide test article for materials and modeling tools evaluation
- Quantify and correct on-orbit dimensional errors through ground and flight experiments

### Deliverables & Schedule:

- Complete low-cost composite curved reflector panels Q1 98
- Complete microdynamic testing of deployable truss Q2 98
- Complete inflatable wave guide proof-of-concept Q3 98
- Verify performance of materials & models on inflatable waveguide POC Q3 99
- Complete proof-of-concept LIDAR photon collector and demonstrate predictable performance Q2 00
- Complete prototype deployable telescope and demonstrate optical performance Q2 02

### Applications for Future Space Missions:

Enables launch in small spacecraft for missions requiring precision large apertures

- Interferometers
- NGST
- LIDAR
- Radiometers

### Applications for Ground:

Field deployable tracking and communications systems

# Breakthrough Materials

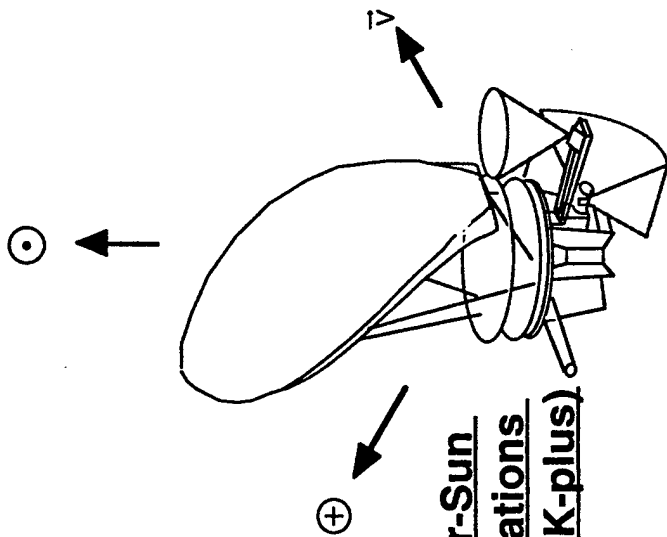

## Near-Sun Operations (2000°K-plus)

### Applications for Future Space Missions:

- Carbon-carbon composites for near-Sun and outer planet missions
- Polymers resistant to space environment for inflatable structures & MLI
- Microcomposite materials for tailored thermal & electrical properties
- Lightweight radiation shielding materials

### Applications for Ground:

High-speed aircraft structures  
Thermal protection for RLV

### Objectives:

- Lightweight materials and affordable fabrication methods to provide multifunctional shields and precision structures for extreme environments
- Tailored material properties for combined functions and efficient operation
- Materials robust to space environment

### Approach:

Develop and test:

- carbon-carbon materials for precision high-temperature structures
- polymers resistant to radiation
- low CTE microcomposite materials for precision mechanisms
- multifunction integrated structural components

### Deliverables & Schedule:

- Transfer soluble imide-based circuits to industry Q2 98
- Low CTE microcomposite for moldable mechanisms Q3 98
- Carbon-carbon-sensorcraft frame Q4 99
- Neutron & conformal radiation shielding materials validated Q4 99

# Lightweight and Multifunctional Structural Systems



**Gas & Aerosol Monitor System (GAMS) Solar Occultation Sensorcraft**  
60Kg, 75W, 0.1m<sup>3</sup>, \$2M  
ea.

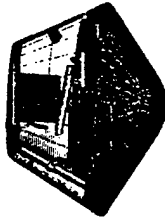

## **Sample Return In-transit Protection**

### **Applications for Future Space Missions:**

Low cost multi-use sensorcraft components and structural hardware integration concepts for extreme environments and distributed networks

### **Applications for Ground:**

Aircraft structures, industrial equipment

### **Objectives:**

Reductions of, relative to the state-of-the-art, 3x system packaging volume, 3x structural mass that is functional during launch only, and 10x cost via fabrication economies and predictable in-space performance/reliability. Sensorcraft structures for extreme thermal and radiation environments.

### **Approach:**

Develop highly integrated subsystem structures that incorporate tailored structural, thermal, electrical, electromagnetic, and radiation-shielding properties in advanced composite and polyimide materials. Validate concepts in focus ground testbeds and flight experiments. In FY 98, increase emphasis on high-temperature and high radiation applications.

### **Deliverables & Schedule:**

- Complete GAMS sensorcraft design Q1 98
- Complete benchless-optics sensorcraft testbed (FTS) Q3 98
- Complete integrated radiation shielding and structure proof-of concept tests Q3 99
- Complete carbon-carbon sensorcraft design for high-temperature focus application

# Structures, Materials, Mechanisms, SEE Technology Roadmap

FY	98	99	00	01	02
Lightweight & Multifunctional Structures & Components	GAMS Sensorcraft Design	Benchless FTS Structure	Validated analysis of Low-cost composites	Extreme Temperature Precision Structures	2X increase post-launch functionality of structural mass (MTPE spacecraft, aeroshells, solar observers, LDAR)
	Low-cost Carbon-carbon Components	Composites with Integrated Thermal & Radiation-Shielding	High Temperature Sensorcraft	Smart Composites	3x decrease in insertion time of space materials
	Materials Assessment for Inflatables	Tailored Microcomposite Mechanisms	Films Tailored for Inflatables	ISSEC Testbed Developed	-3x decrease in package volume; 4x increase in aperture size
Breakthrough Materials	Rigidizable Tubes	3m inflatable reflector ground demo	25m inflatable reflector ground demo		
	Deployable & Inflatable Structures	Deployable Photon Collector	Controlled Flexible Reflector Panel Testbed		
Structural Dynamics & Geometry Control	Advanced Actuation Materials Characterization	Microlaunch Testbed			
	Space Environmental Effects	Space Science NRA	Electrically-conductive Thermal Control Coatings	3X displacement, 5x less power actuation	5x increase in operational-life of space materials
	2nd-Phase SEE NRA	Space Science NRA	Spacecraft Charging Guidelines	EMI Characterization	
	Electronics Test Bed on STRV1 c/d	Electronics Test Bed on STRV1 c/d			

143

# Structural Dynamics & Geometry Control

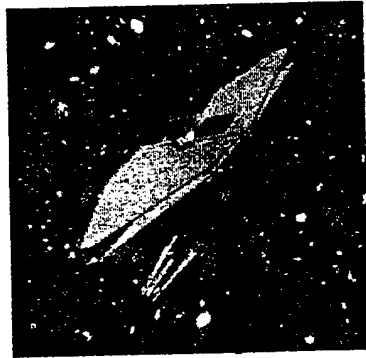

Next Generation  
Space  
Telescope

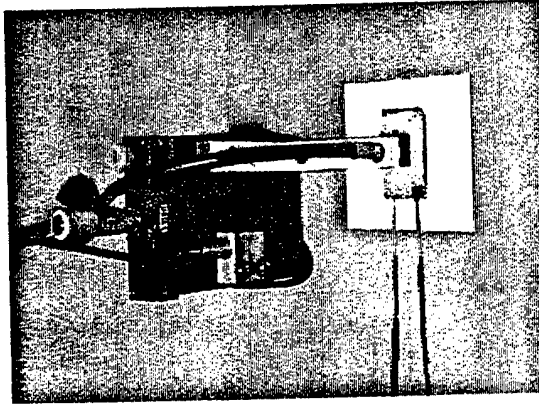

THUNDER Long-  
Stroke Actuator

## Objectives:

- Cryogenic and high temperature actuator capability
- 10x improved dynamic actuator life and efficiency
- Efficient, affordable long-stroke actuators for instrument scanning, optical positioning, interferometer delay lines

## Approach:

- Develop efficient motorless actuators for positioning and motion suppression in extreme environments
- Develop system level methods for vibration suppression and precision pointing when using flexible components
- Validate on focus testbeds

## Deliverables & Schedule:

- Complete characterization of THUNDER & Rainbow actuator concepts Q2 98
- Demonstrate cryogenic position-hold actuators Q1 99

## Applications for Future Space Missions:

Low-cost, lightweight structures with integrated efficient actuation and controls for on-orbit correction of geometry errors and changes and suppression of dynamic response

## Applications for Ground:

Smart structures that adapt to changing environmental conditions for aircraft, buildings, bridges



## Relevant Power Technologies

- Thermophotovoltaics
- Photovoltaics
- Li-ion Batteries
- Fuel Cells
- Free Piston Stirling Engines
- Power Management and Distribution

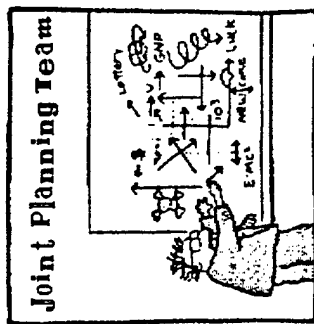

# Spacecraft System Power Technology Program

## Major Milestones

FY	1997	1998	1999	2000	2001	2002	2003
<b>PHOTOVOLTAICS</b>	MBG CONC. NMP HDW. DELIVERED 2.7 KW 80 W/kg	COMM'L >24% MBG CELLS, 3 x 7cm UPDATE RADIATION HANDBOOK	UNIV RAD DAMAGE MDL COMP	30% MBG CELL 300 W/kg ARRAY >500 W/m <sup>2</sup>	\$300W ARRAY DEMO HI-VOLT IMF MODULE		
<b>ENVIRONMENTAL EFFECTS</b>	EWB 5.0 PATHFINDER LANDING	VERIFY HI VOLT DESIGN NASCAP/LEO UPGRADE	ISS PC LAUNCH	NASCAP/GEO UPGRADE	MOON. GEO EWB		
<b>CHEMICAL STORAGE</b>	100 W-hr/kg 10 YEAR LEO BATTERY DESIGN CPV NH <sub>2</sub> LI-ION BATTERY DESIGN FOR TRANSFER TO FLIGHT @ 100 W-hr/kg	LI-ION SOLID POLYMER BATTERY DEMO LOW TEMP LI-ION FOR MARS PROGRAM	BIPOLAR NiMH 100 W-hr/kg 2x SOA 1/2 VOLUME 20 YEAR GEO DESIGN	2X SOA 100 W-hr/kg CPV NH <sub>2</sub> BATTERY 10 YEAR LEO	BIPOLAR NiMH 100 W-hr/kg 2x SOA 1/2 VOLUME 20 YEAR GEO BATTERY		SPACE PROTOTYPE LI-ION, 150 W-hr/kg 2-4x SOA, 250 W-hr/1/2 SOA COST 2000 CYCLE LIFE
<b>MECHANICAL STORAGE FLYWHEELS</b>	ADV TECH COMP. LEO FES LAB SYSTEM (44 W-hr/kg)	PROTOTYPE IPACS (37 W-hr/kg)	10x SOA W/kg SYSTEM - LONG LIFE	GEO BENCH MODEL (88 W-hr/kg)			2 <sup>nd</sup> GEO BENCH MODEL (120 W-hr/kg)
<b>POWER MANAGEMENT, DISTRIBUTION</b>	INITIAL MODULAR TESTBED COMPLETE ISUS PMAD DEMO	HIGH POWER PEBB TEST-BED ADV. PRKE	BRASSBOARD POWER DIST. UNIT HI DENSITY WIDE TEMP 25°C - 300°C NO RHU'S	PEBB BASED PMAD DEMO	AUTONOMOUS MODULAR SYSTEM TEST-BED		
<b>RADIOISOTOPE CONVERSION ADVANCED SYSTEMS</b>	>20% EFF TECH. SELECTION 3-5 x LESS Pu	DEMO POWER DEVICE/DIAMOND/ITE COOLER FOR THERMAL MANAGEMENT	20% EFF. PROTOTYPE OPERATION				
<b>POWER MATERIALS</b>	DEMO LOW TEMP POWER SUPPLY	DEMO DURABIL. OF HST SM3 THERM. CONT. MATL.	DEMO ELECTRO-CHROMIC RADIATOR	DEMO 3X REDUCTION IN SOLAR ARRAY BLANKET MASS			

UNIQUE FACILITIES - ALL REQUIRED FACILITIES EXIST (WILL SUPPLY LIST IF REQUIRED)

\* INDICATES JOINT, CO-OPERATIVE PROGRAM, FUNDING LEVERAGE

RJS97-014.6

# Photovoltaic Conversion Technology

## FY 97 Accomplishments Technology Development of Low Bandgap Solar Cell for Thermophotovoltaic Energy Conversion

- Monolithically Interconnected Module (MIM) InGaAs cell developed.
- Provides 2x increase in deep space power system efficiency.
- Device technology transferred to a small, woman-owned business, who is currently under contract with Bettis Atomic Power Laboratory to develop the MIM device.

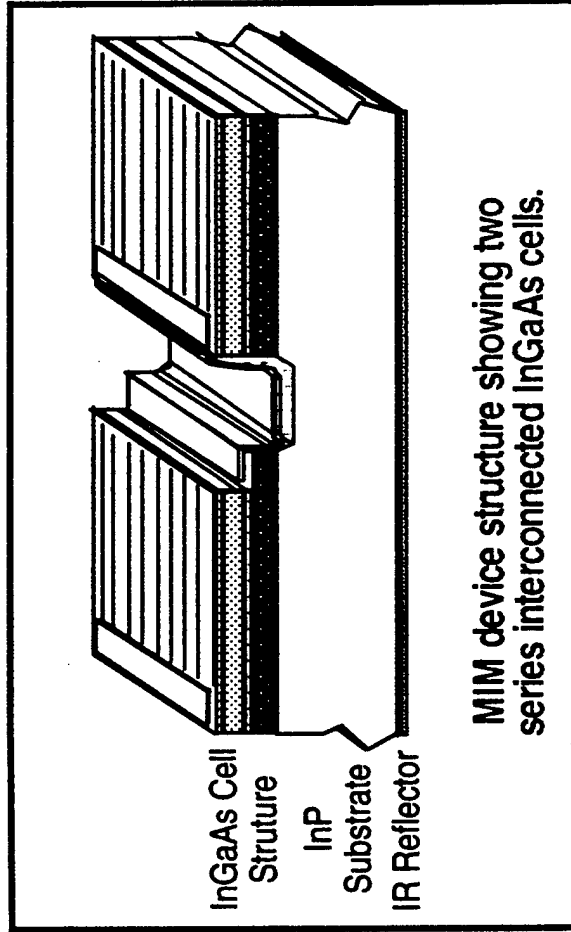

NASA space technology transferred to major aerospace corporation (Westinghouse) for multi-million dollar development effort.

# Spacecraft Systems Power Technology

## Technology Development of Dual Use Rechargeable Lithium-Ion Polymer Batteries

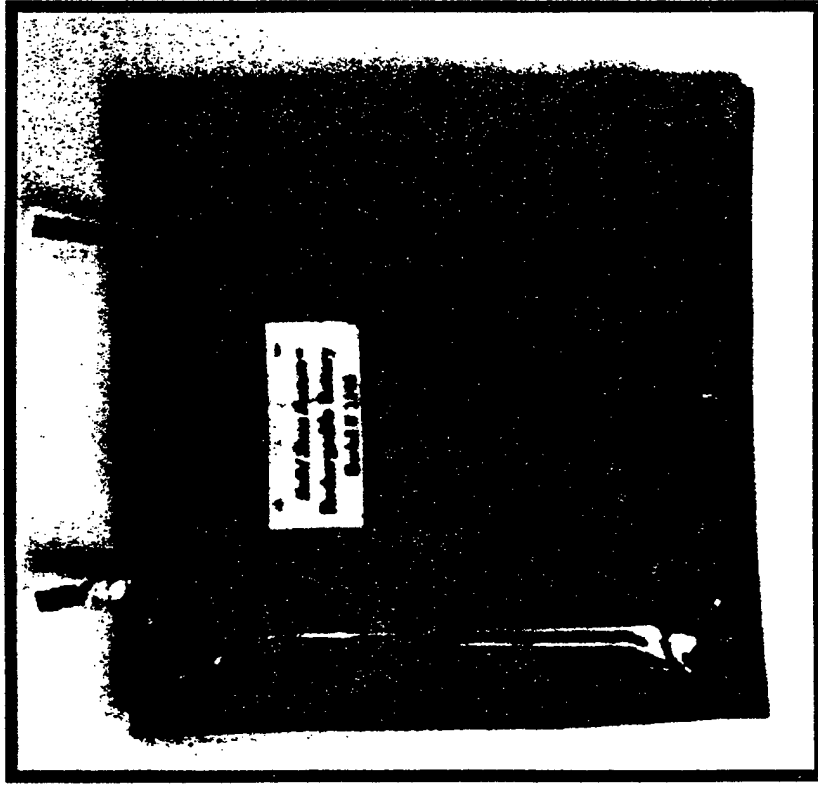

- **Cooperative TRP effort very successful**
  - Progress made toward replacement of NiCd batteries for Military and space users
- **Major performance and manufacturing advances achieved for dual-use applications**
  - Demonstrated 3x specific energy of SOA NiCd toward target of 200 Whr/kg (6x NiCd)
  - Automated production capability and development
- **Penetration of markets for laptop computers, portable military applications and NASA missions is imminent**
- **Combination of in-house, industry, university (CSP) and SBIR efforts being pursued to extend life, increase energy density and power density of lithium-ion solid polymer battery**

**Battery cells and cell packs currently being tested by commercial, military and NASA end users**

# Spacecraft Systems Power Technology Program

## FY'97 ACCOMPLISHMENT

### High Capacity, Light Weight Lithium-Ion Battery

- Developed oxidation-intercalation techniques to produce lithium-ion battery anodes with greater than 6x state-of-the-art lithium to carbon concentrations
- High Li:C ratio means high power density unit mass for the batteries
- Identified high performance carbon precursor materials
- Optimized anode synthesis process to minimize cost and maintain performance

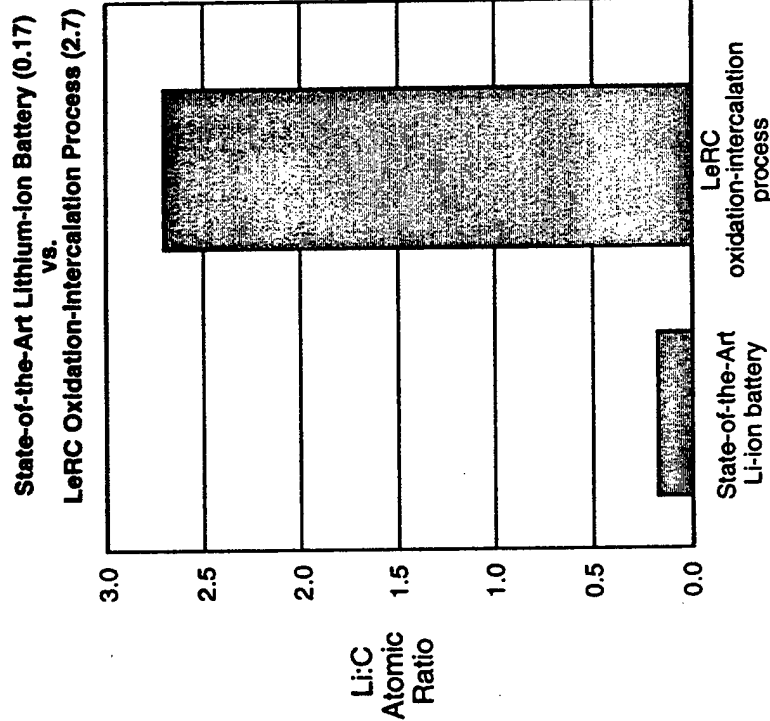

**The demonstrated high Li:C atomic ratio anodes are necessary for high power density lithium-ion batteries**

## FY '97 FUEL CELL ACCOMPLISHMENTS

### Hydrogen / Oxygen Fuel Cell Power System for Scientific Balloons

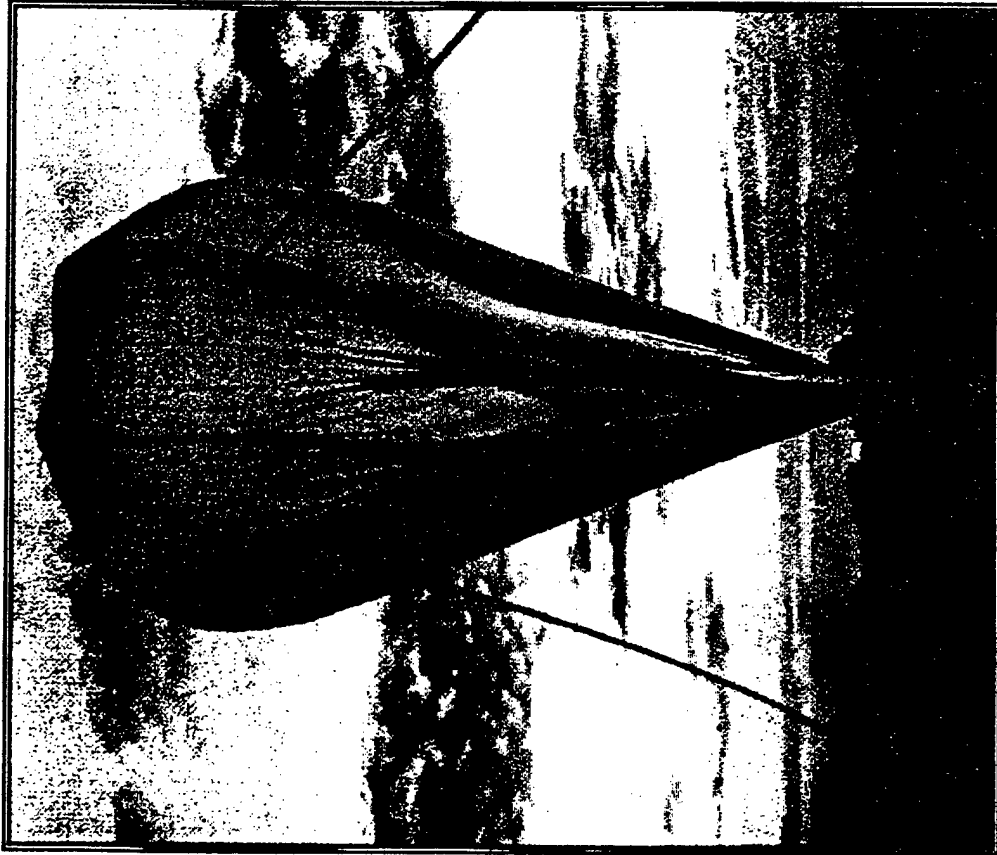

- Will demonstrate operation of a 200 W hydrogen / oxygen PEM fuel cell power system for use on scientific balloons
- Preliminary testing of the fuel cell has verified performance
- Testing of the complete fuel cell power system in the SMIRF facility has been completed successfully
- Flight test of power system scheduled for Spring '98

LeRC

MW97-004.6



# Spacecraft Systems Power Technology Program

## FY97 Accomplishments

### Advanced Radioisotope Power Source

- Stirling chosen as back-up power system to AMTEC
  - DOE Initiating sole source contract w/STC for brassboard
- 36 We RSG Phase 1 SBIR (NASA) awarded STC 3/17/97
  - Design initiated
- Similar 10 We radioisotope Stirling converter (RSG) has operated 32,500 hours (3/19/97) (3.7 years) without maintenance nor failure nor degradation with time
- All power converter component technologies are tested except for hermetic sealing, and the dynamic balancer
  - Flexures tested @ 65% overstroke for 3.7 years **No Failures**
  - Alternators tested for 3.7 years **No Failures**
- 7 of 10 We RSG's ready for field tests (3 electrically heated, 4 to be fueled)
- 350 We RSG's to be tested in '97 to determine vibration control and mitigation
  - 3 on test in Europe
  - 2 STC/LeRC units fab'd/test 5/97

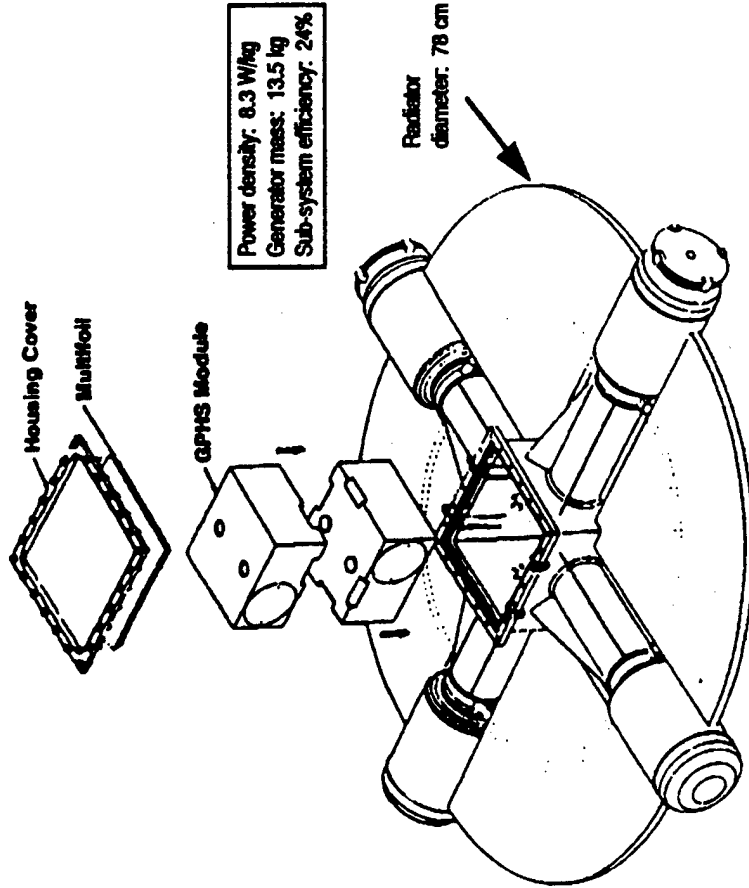

4 of 38 We Stirling Power Converters

- Completed two conceptual flight Stirling generator designs
  - Al Schock (OSC) design above

# Power Management and Distribution

## FY 97 Accomplishments

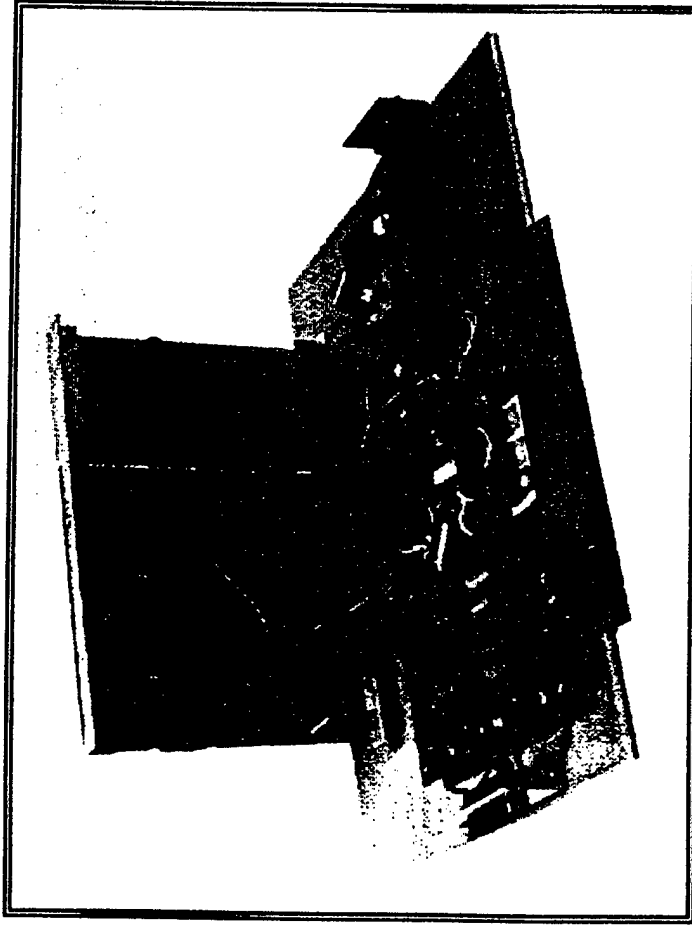

- **Developed a low power test-bed for Power Electronic Building Blocks (PEBB's)**
  - 30 Watts
  - 28 to 3.1 Volt Converter
  - 85% Conversion efficiency
  - SEU tolerant
- **Provides capability for identifying PEBB requirements, modular component requirements, and evaluating controls and redundancy schemes**



## Concluding Remarks

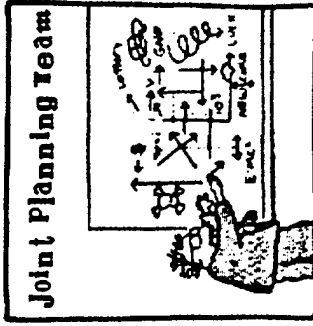

- **NASA has a relatively small but aggressive Spacecraft System Technology Program**
  - Responsive to USER needs
- **Many Joint Programs with DOD**
  - USAF, ARPA, BMDO
- **Key technologies relevant to ARO needs**
  - This meeting
- **Willing to work with you**
  - Help
- **A E Y W T K**



**“RUDIMENTARY PHYSICS OF MAN-POWERED SYSTEMS”**

**Dr. Arthur Ballato**

**CECOM  
Ft. Monmouth, NJ 07703-5201**

# Rudimentary Physics of Man-Powered Systems

Arthur Ballato

US Army Communications-Electronics Command  
Fort Monmouth, NJ 07703

## Synopsis

The most efficient production and transfer of power in systems takes place when the source impedance is matched to the load. For man-powered systems, this match is complicated by a number of factors. Indeed, for the class of problems encountered in man-powered systems, not only should the impedances ( $F/v$ ) be matched, but also the elastances ( $F/x$ ). In general, this is not possible, and compromises must be made. The situation is akin to that of needing to match both Reynolds and Froude numbers in certain fluid mechanics design problems. Part of the matching problem is the fact that humans are 'soft,' while most transducer materials are 'hard.' A rudimentary discussion of the physics/physiology involved is given, and an approach sketched for improvements.

Because of the mismatches in the ratios ( $F/x$ ) and ( $F/v$ ) for the man/machine interface that exist at the macroscopic level (one man and, e.g., one spring), the problem might have a more satisfactory resolution at the microscopic level. At present, the situation is much the same as obtained in 1947 with respect to the transistor. One such device was relatively large, and largely worthless. It was only with the advent of the IC and increasingly greater packing densities that the importance and utility of such devices grew. At present we are at the 'one transistor' level. At the microscopic level, the mechanical impedances and elastances of materials such as film piezoelectrics are more favorable for matching to the human. When coupled with distributed active circuitry for 'piezo-power-pixel' generation, accumulation, and management, the very act of wearing clothing in everyday activities can lead to the production of useful electrical output without the human-factors difficulties associated with wearing constricting apparatus or performing tiresome repetitive motions.

## COMMENTS TO VuGRAPHS

---

01. Title: The title of this talk is "Rudimentary Physics of Man-Powered Systems." We start with an enormously expanded view of things, and then focus down on our subject. This is done to make a point: simple physical considerations, to be touched on later, indicate that the present-day approach to the soldier-power problem operates, in many respects, on the wrong scale. The proper scale for the problem of matching the impedance and elastance of a human to energy production components must be addressed. In the early years of this century, a child prodigy expressed her understanding of the world in the words: "Pipes are steel, but bones are real." In a real sense our job is to elucidate and maximize the coupling between these domains.

02. Limits of distance and mass in the universe [5]. Man's position is seen to be reasonably centrally located between the extremes.

03. Quantum-Gravity (Planck) Units [12]. These units are comprised of combinations of the natural constants  $\hbar$  (Planck's constant),  $c$  (the speed of light), and  $G$  (Newton's gravitational constant). One can also add to this list the Planck force,  $F = G (m_{Pl})^2 / (\ell_{Pl})^2 = c^4 / G = P_{Pl} / c = 1.20 \cdot 10^{44}$  N. All of these values are seen to be wildly disproportionate to the scale of man.

04. Energy / Power Comparisons. Man is located in a central position. The tank entry is for the Abrams (M1A1) 120 mm cannon. Additional entries: Diesel fuel, 38.4 MJ/ℓ and gasoline, 34.9 MJ/ℓ.

05. Limits on the size of terrestrial creatures [3].

06. Creatures large and small [3]. Our hero is seen just below the Baluchitherium (3).

07. Of the four basic forces, the strong and weak are too short range for our considerations. We lump inertia with gravity because of Einstein's Equivalence Postulate; the origin of inertia is unknown at a fundamental level. All other 'forces' are electromagnetic (EM) in origin. Man's everyday world is dominated by EM and gravitational fields. Reynolds number:  $\rho$  is the mass density,  $\eta$  is the viscosity coefficient, and  $\ell$  is a length characteristic of the problem. Froude number:  $g$  is the local acceleration of gravity,  $\sim 9.81$  m/s<sup>2</sup>, and  $\ell$  is a length characteristic of the problem. It is usual that simultaneous constraints on a problem, such as  $Re$  and  $Fr$ , cannot both be completely satisfied, and compromises must be made.

08. Reynolds number domain for certain creatures and man-made structures [8]. For submarines, the Mach number is normalized to the speed of sound in sea water,  $\sim 1,560$  m/s.

09. The Froude number can be thought of as the ratio of centripetal to gravitational forces acting on an inverted pendulum [3]. When  $Fr \sim 1$ , walking breaks into running, when more leg-time is spent in the air.

10. Size-independent dimensionless groups in mammals [3]. Small allometric mass exponent means  $\sim$  independent of mass ( $\alpha\lambda\lambda\omicron\sigma\varsigma =$  unlike).

11. Total weight lifted (press + snatch + clean-and-jerk) vs body weight [3]. This is a measure of maximum exertion; the slope of  $2/3$  is indicative of constancy of bone stress, i.e., is proportional to cross-sectional area.

12. Kleiber's Law [3]. Graphical illustrations are given in VuGraphs 13 and 14.

13. Mass-specific metabolic rate vs body mass [3]. The curve has the form  $(W/kg)_{\text{resting}} \propto (M)^{-1/4}$  as predicted from Kleiber's Law. For a 75 kg man, the curve gives  $\sim 1.4$  W/kg, and 105 W. The conversion from kilocalories to joules is: 1 kilocalorie = 1 kcal = 4, 186.8 J.

14. Heat production vs body mass for mammals [3]. The curve has the form  $(MJ/day) \propto (W)_{\text{resting}} \propto (M)^{3/4}$  as predicted from Kleiber's Law. The metabolic rate has a slope of  $\sim 3/4$ ; by the principle of 'elastic similarity,' this is  $\propto$  muscle cross-section, which is  $\propto$  force. The intercept at 75 kg (man) gives  $\sim 115$  watt.

15. Energy Cost of Lateral Locomotion [2, 3, 15]. VuGraph 16 has a slope of  $\sim -1/3$  for terrestrial animals; this is not for running; for running, the slope is  $\sim 0.40$ .

16. Cost of transport vs body mass [3]. Various modalities have differing slopes. These are not for racing speeds; see VuGraph 15.

17. Where are we now? Having observed some of the physiological characteristics of man (and other creatures), this question points to comparisons of energy sources (including man), and the prospects for transduction from one form to another.

18. Conversion Efficiencies. Adapted from Table V.2, p. V.2 of [7]. We would like soldier-power conversion from mechanical to electrical to be as efficient as possible; the 99% figure listed is for very large commercial stations.

19. Energy storage by batteries and elastic springs compared. Also listed are some SUO requirements. It is interesting to note that if sleep is considered 'recharging one's batteries,' then man as a secondary battery is good for 25k recharges.

20. Rations [4, 13, 14]. The values given represent averages over an entire day (86,400 seconds). A resting man requires  $\sim 1$  kcal/(kg-hour)  $\sim 1.16$  W/kg. The figure can be twenty times this for an athlete in action, or  $\sim 23.3$  W/kg; for a mass of 72.6 kg, this works out to  $\sim 1,700$  W. The caloric demands are stated without regard for nutritional balance. The 'fuel mix' is very important; for example, if simply burned, then the energy

content (kcal/gm) of any fat is  $\sim 9$ ; alcohol is  $\sim 7$ ; any sugar is  $\sim 4$ . It would seem that this should be the order for deriving dietetic energy, but "fat burns in the flame of carbohydrates;" (one needs carbohydrates to metabolize fats). Therefore, one needs carbohydrates to burn fat energy into  $\text{CO}_2$ . Since most people have excess fat on the body, if one was forced to choose a single substance for energy during a mission, sugar would be appropriate; moreover, the brain runs on glucose. Alcohol represents 'false calories' in the sense that the efficiency of its energy transfer to ATP (the energy the body uses) is low, and actually requires some energy to turn into fat. [I am indebted to the following individuals at US Army Natick RDEC; Soldier Systems Command; and Research Institute of Environmental Medicine, Natick, MA for information supporting this VuGraph: Dr. Irwin Taub, Judy Aylward, Dr. Pat Dunn, Reed Hoyt, and Maureen Abbruzzese.]

Nutritional 'calories' are kilocalories; the numerical factor for converting kilocalories to joules is: 1 kilocalorie = 1 kcal = 4,186.8 J. A useful rule-of-thumb for converting kcal/day to watt is: 2,000 kcal/day  $\sim$  100 W. By comparison, the sun radiates  $\sim 3.9 \cdot 10^{26}$  W, so the flux incident on the Earth is  $\sim 1.4 \cdot 10^3$  W/m<sup>2</sup>; at the surface it is  $\sim 1.0 \cdot 10^3$  W/m<sup>2</sup>, or only about 10 times the heat production of a resting human (see the caption to VuGraph 37).

21. Heckmann Diagram [11]. Phenomenological couplings between the intensive and extensive variables of the electrical, mechanical, and thermal fields. The effects noted on the diagram can be used for soldier-powered devices; the piezoelectric effect is particularly apt because of the direct conversion of mechanical to electrical energy.

22. The 32 crystallographic point groups; the acentric groups are piezoelectric, with the exception of group 432.

23. Linear elastopiezodielectric constitutive equations. These are generalized versions of Hooke's Law: stress is proportional to strain; in the piezoelectric case, one adds a term to represent the electric force. This effect is apt for use in soldier-powered systems because of the direct nature of the transduction mechanism.

24. Piezoelectric Coupling Coefficients. These are dimensionless measures of the efficacy of transduction of energy from mechanical to electrical or vice-versa.

25. Comparison of Ceramic Actuator Technologies. For some of the newer materials and configurations (such as functionally gradient materials), piezoelectric strain can be substantial.

26. Electrical & Mechanical Variables. In dealing with soldier-generated power, the quantities V, Q, I, F, x, and v must be dealt with; the familiar products, energy and power, are often quoted as specifications. The quotients, elastance and impedance, have just as often not been adequately dealt with. Just as with Re and Fr (VuGraph 7), it is usually not possible to satisfy both constraints simultaneously, particularly in the time-varying case.

27. Matching. An example of the impedance/elastance matching problem is the fact that it is more tiring to split logs with a small hatchet than with a large ax; the hatchet requires a greater impact speed, and the kinetic energy that must be given to the arms results in a greater rate of fatigue.

28. Man as Seen by .... The big picture, given in earlier VuGraphs, starts with the cosmologist; the physiologist deals with the man as a macroscopic energy producer. The atomic picture of the physicist and chemist is too small. At the level of the biologist ... cells, the impedance and elastance levels are more appropriate to generation of casual soldier power.

29. Man-Sized Units. Compare with VuGraph 3; the corresponding force levels are  $F = P / v = 10^{-1}$  to  $10^2$  N (roughly 10 gram to 10 kg mass equivalent). Impedance and elastance levels should be commensurate when attempting to match between the human and a device, be it piezoelectric or any other type.

30. Volume vs number of cell types; a 75 kg man (with ~ the density of water) has a volume of  $\sim 7.5 \cdot 10^4 \text{ cm}^3$  and  $\sim 10^{13}$  cells.

31. Cells. Cell size is midway between man considered as an individual and as an aggregation of atoms. We are at the analogous stage of development that the transistor was in 1947; single transistors, by themselves, are not very useful; their utility comes from aggregation.

32. Summary. This is actually a summary of what future developments might be like, given proper development of the ideas sketched here. One must differentiate between 'deliberate' power generation, where, e.g., a soldier turns a crank attached to an electric generator, and 'casual' power generation, where, e.g., the clothing, is capable of generating power when subjected to arbitrary movements. These may be walking, gesturing, or any movements. For this to be possible, the material is 'smart,' and can sense the type of movement (how the deformation is occurring), can actively switch the individual pixels in polarity and topology (series/parallel, etc.) to balance dynamically by impedance/elastance changes in order to accommodate the demands for energy/power storage, distribution, and use. 'Active matrix' display panels, with a transistor at each pixel, is indicative of what can be done. With the power requirements of mobile (man-portable) communications systems dropping at the dramatic current rates (reminiscent of Moore's Law), it is projected that the soldier may well have his communications needs met in the future by a steady-state power requirement of 5 watt, or less; this should be well within the capability of a soldier-powered configuration for power harvesting.

33. References.

34. References (continued).

35. References (continued).

36. Appendix 1. Dimensional formulas [3].

37. Appendix 2. Body surface vs body mass [3]. Area is  $\propto (\text{volume})^{2/3} \propto (\text{mass})^{2/3}$ ; the slope of the curve is  $2/3$ . For a man of  $\sim 75$  kg, the area is  $\sim 1.5 \text{ m}^2$ ; if heat production is 150 watt, then the flux is  $100 \text{ W/m}^2$ . This is 10% of the incident heat flux from the sun at the Earth's surface (see the caption to VuGraph 20), and might lead one to conclude that a sizable portion of this heat could be made available for conversion to electric energy. One problem with usage of body heat is its quality, viz., the spectral distribution as a 'blackbody' radiator ( $T = 37^\circ \text{ C}$ , versus  $\sim 5,500^\circ \text{ C}$  for the sun), another is the inefficiency of conversion using transport phenomena (conduction); still another is the threat of departure from homeostasis, quite apart from psychological considerations.

38. Appendix 3. Oxygen consumption vs body mass [3], for guinea pigs. The slope of  $\sim 2/3$  is  $\propto$  lung area.





**Prospector IX Workshop:  
Human Powered Systems and Technologies  
Durham, N.C.  
3 November 1997**

---

# **Rudimentary Physics of Man-Powered Systems**

**Arthur Ballato  
US ARMY CECOM  
FORT MONMOUTH, NEW JERSEY 07703**

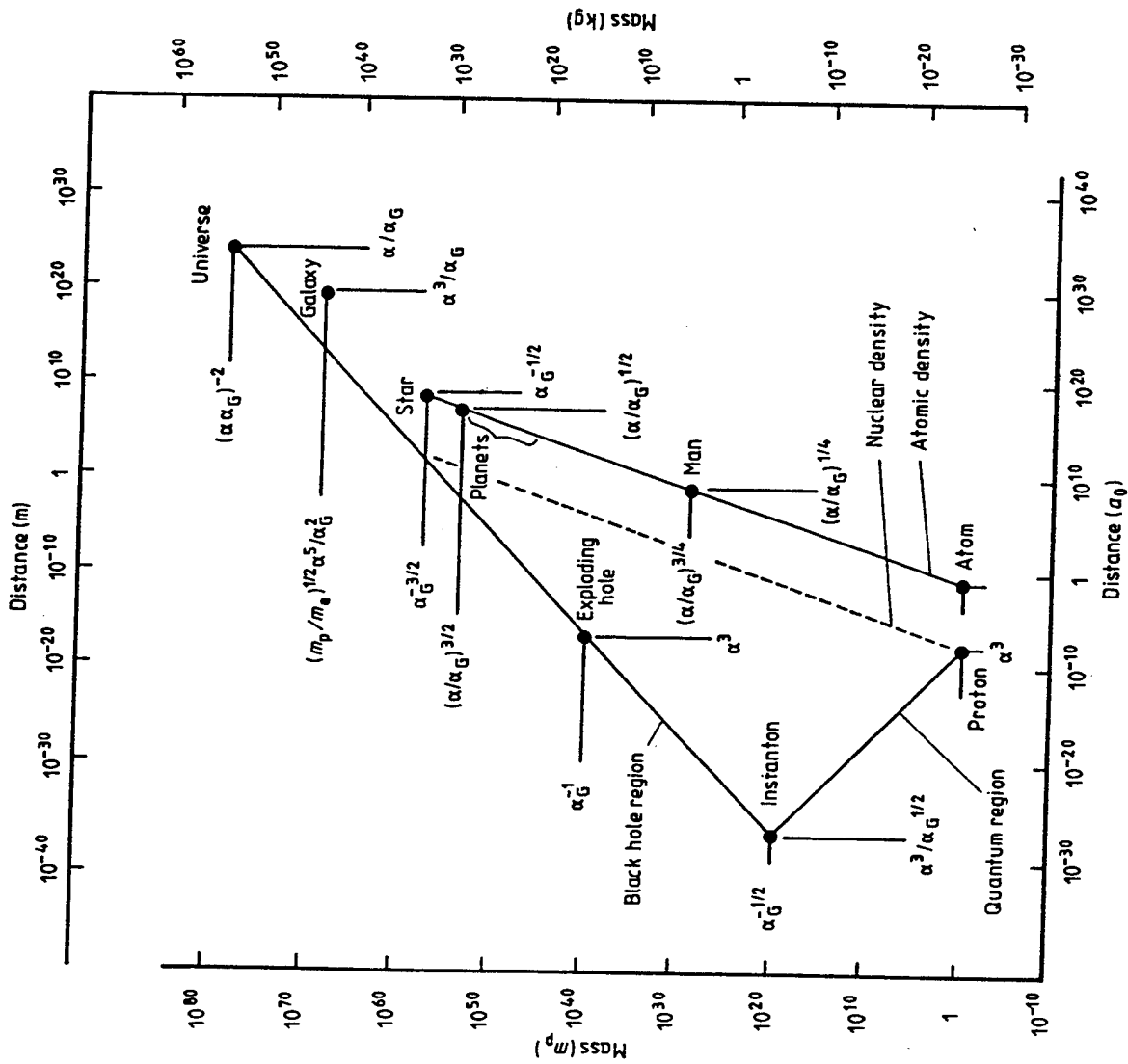

## QUANTUM-GRAVITY (PLANCK) UNITS

MASS       $m_{Pl} = (\hbar c / G)^{1/2}$        $2.177 \cdot 10^{-8}$  kg

LENGTH       $l_{Pl} = (\hbar G / c^3)^{1/2}$        $1.616 \cdot 10^{-35}$  m

TIME       $t_{Pl} = (\hbar G / c^5)^{1/2}$        $5.391 \cdot 10^{-44}$  s

ENERGY       $E_{Pl} = (\hbar c^5 / G)^{1/2}$        $1.956 \cdot 10^9$  J

VELOCITY       $v_{Pl} = c$        $2.998 \cdot 10^8$  m/s

POWER       $P_{Pl} = (c^5 / G)$        $3.628 \cdot 10^{52}$  W

## ENERGY / POWER COMPARISONS

---

- H transition (1420 MHz)     $E = 9.4 \bullet 10^{-25}$  J/photon
- Human                             $P = 10 - 1000$  W
- Automobile engine         $P = 72$  kW input;    9 kW output
- Tank cannon                     $E = 40$  MJ input; 11.4 MJ output
- US Power grid                 $P = 400$  GW @ 60 Hz  
     $E = 6.7$  GJ per cycle
- Pulsars                             $P = 2 \bullet 10^{29}$  to  $5 \bullet 10^{31}$  W @ 200 Hz  
     $E = 2.5 \bullet 10^{29}$  J per cycle ( $10^{20}$  US grids)

(kg)

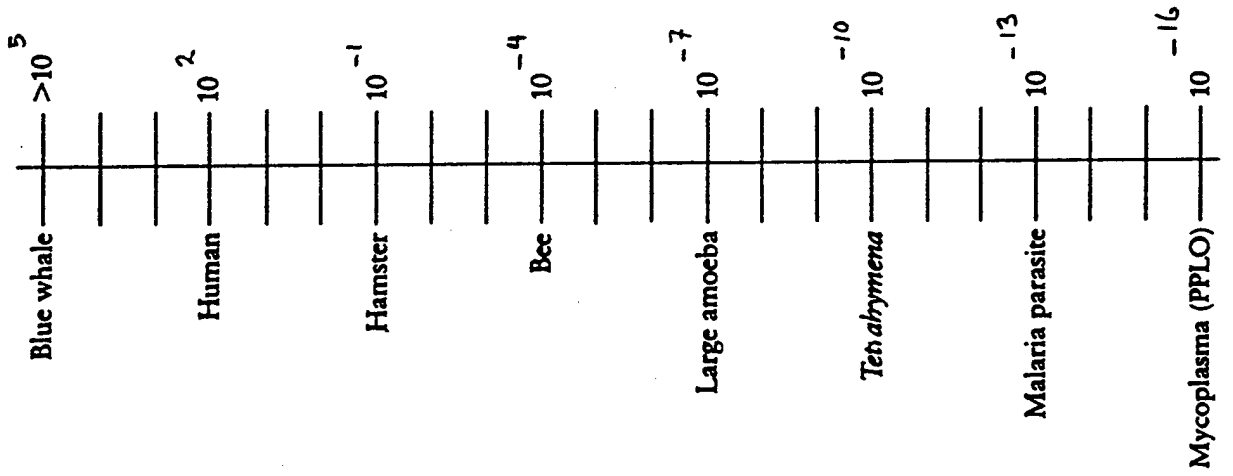

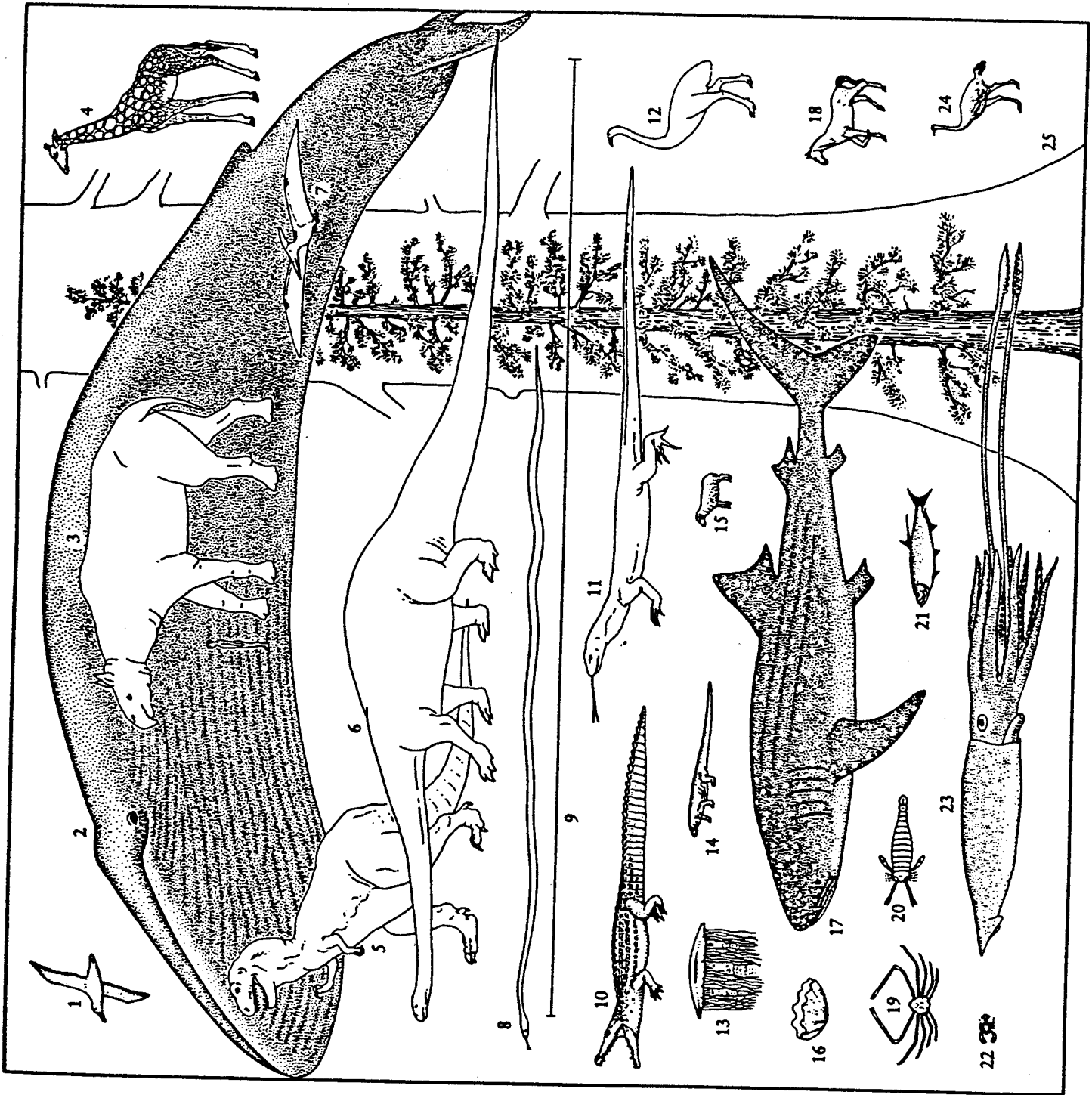

Forces:

[weak, strong]  
gravity/inertia  
electromagnetic: viscosity, friction, cohesion, surface tension, elasticity, etc.

Large creatures: gravity dominates

Small creatures: viscosity, surface tension, ... dominate (EM)

Ant can support many ants; a horse can't support the weight of another horse  
Ants can fall from trees unharmed; men can't

Dimensionless numbers:

$$\text{Reynolds number} = \text{Re} = \rho \cdot \ell \cdot v / \eta$$

Re is the ratio of inertia force to the viscous force on a fluid

Re small: viscous forces dominate; flow smooth, sluggish; drag  $\propto v$  (Stokes)

Re large: inertial forces dominate; flow swift, often turbulent; drag  $\propto v^2$

$$\text{Froude number} = \text{Fr} = v^2 / g \ell$$

Fr is the ratio of inertia force to the gravity force on a fluid

Fr small: gravitational forces dominate

Fr large: inertial forces dominate

Reynolds number = inertial force / viscous force =  $\rho \cdot v \cdot \ell / \eta$

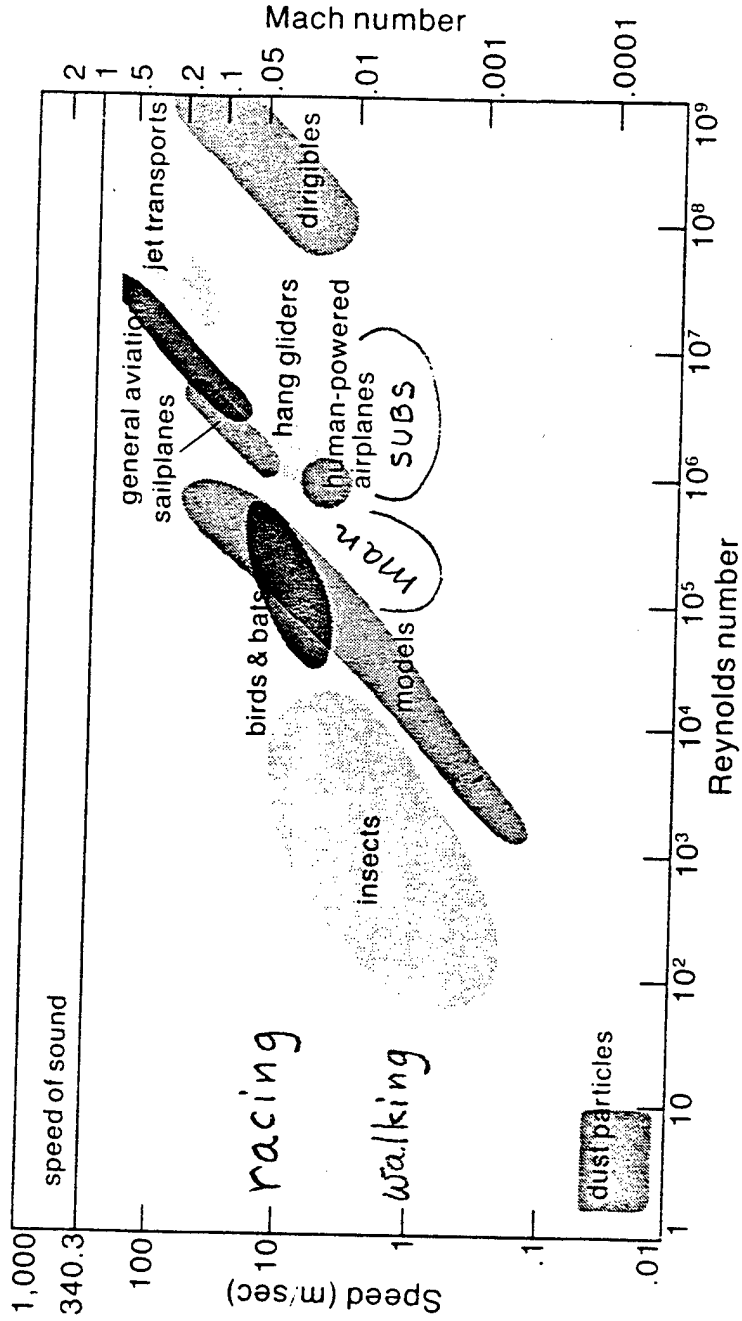

American Scientist, Vol. 77, March-April 1989, p. 167.

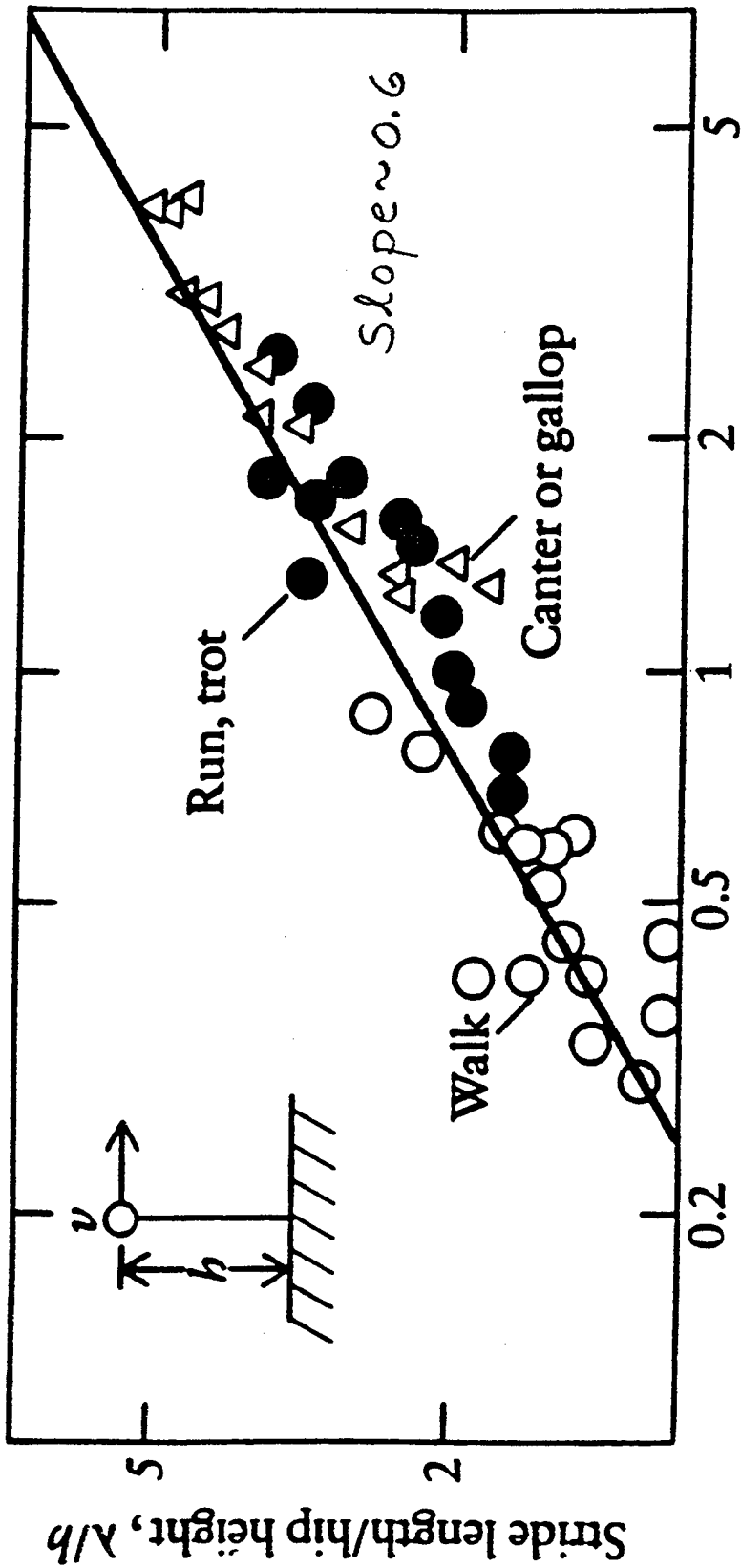

Speed/(gravity x hip height)<sup>1/2</sup>,  $v(gh)^{-1/2}$   
 (Froude number)<sup>1/2</sup>

Centripetal:  $m v^2/h$  } Ratio =  $v^2/gh = \text{Froude}$   
 gravitational:  $mg$

Size-independent dimensionless groups in mammals.

Dimensionless group	Numerical value for an animal weighing 1 kilogram	Allometric mass exponent *
1. $\frac{\text{tidal volume}}{\text{breath time}} / \frac{\text{heart stroke volume}}{\text{pulse time}}$	2.0	0.00
2. $\frac{\text{mass of blood}}{\text{mass of heart}}$	8.3	0.01
3. $\frac{\text{velocity of pulses waves in the aorta}}{\text{velocity of blood in the aorta}}$	26.0	-0.05
4. $\frac{\text{pulse wavelength in the aorta}}{\text{length of the aorta}}$	8.7	-0.05
5. $\frac{\text{time for 50\% of growth}}{\text{lifespan in captivity}}$	0.03	0.05
6. $\frac{\text{gestation period}}{\text{lifespan in captivity}}$	0.015	0.05
7. $\frac{\text{respiratory cycle}}{\text{lifespan in captivity}}$	$3.0 \times 10^{-9}$	0.06
8. $\frac{\text{cardiac cycle}}{\text{lifespan in captivity}}$	$(1.5 \times 10^9)^{-1} = 6.8 \times 10^{-10}$	0.05
9. $\frac{\text{half-life of drug*}}{\text{lifespan in captivity}}$	$0.95 \times 10^{-5}$	0.01

\*Methotrexate. \*  $\approx$  independent of mass

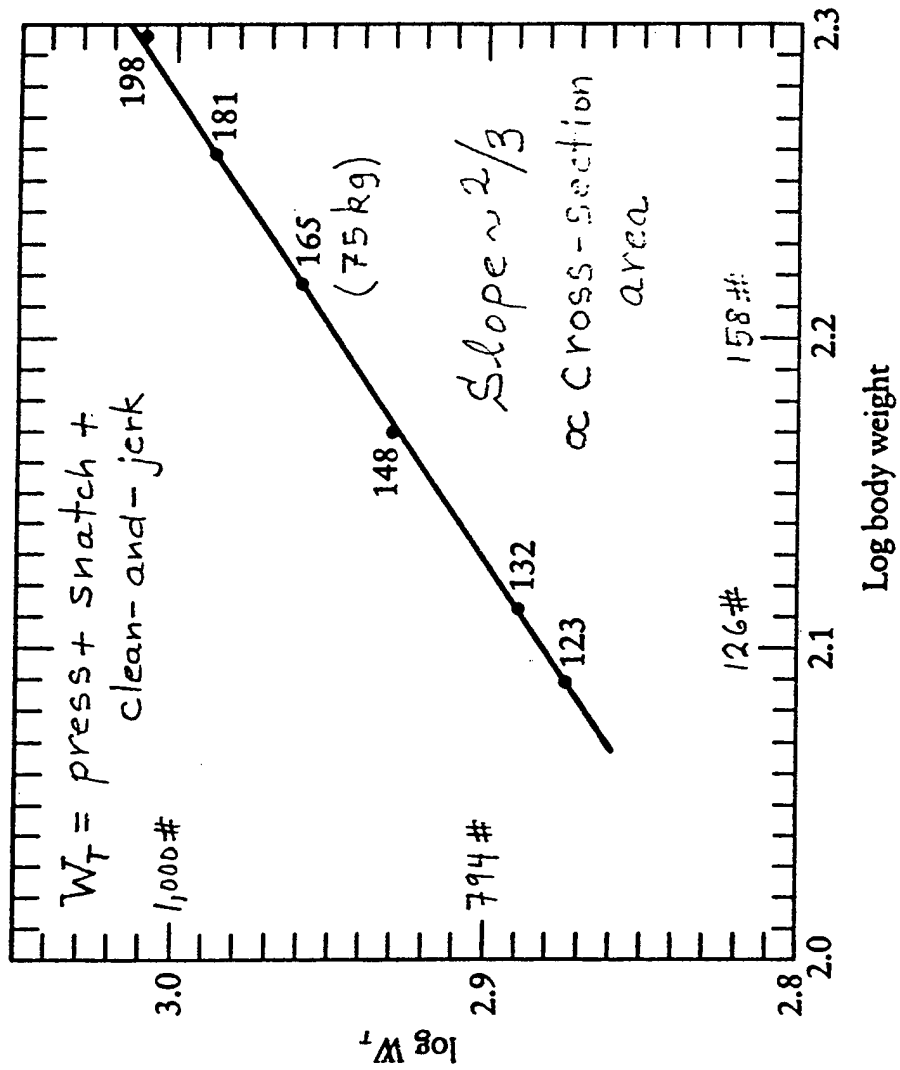

# KLEIBER'S LAW

---

An animal's resting metabolic rate is proportional to (body mass)<sup>3/4</sup>

$$(\text{MJ/day}) \propto (W)_{\text{resting}} \propto (M)^{3/4}$$

Therefore,

$$(W/\text{kg})_{\text{resting}} \propto (M)^{-1/4}$$

Larger animals are metabolically more efficient.



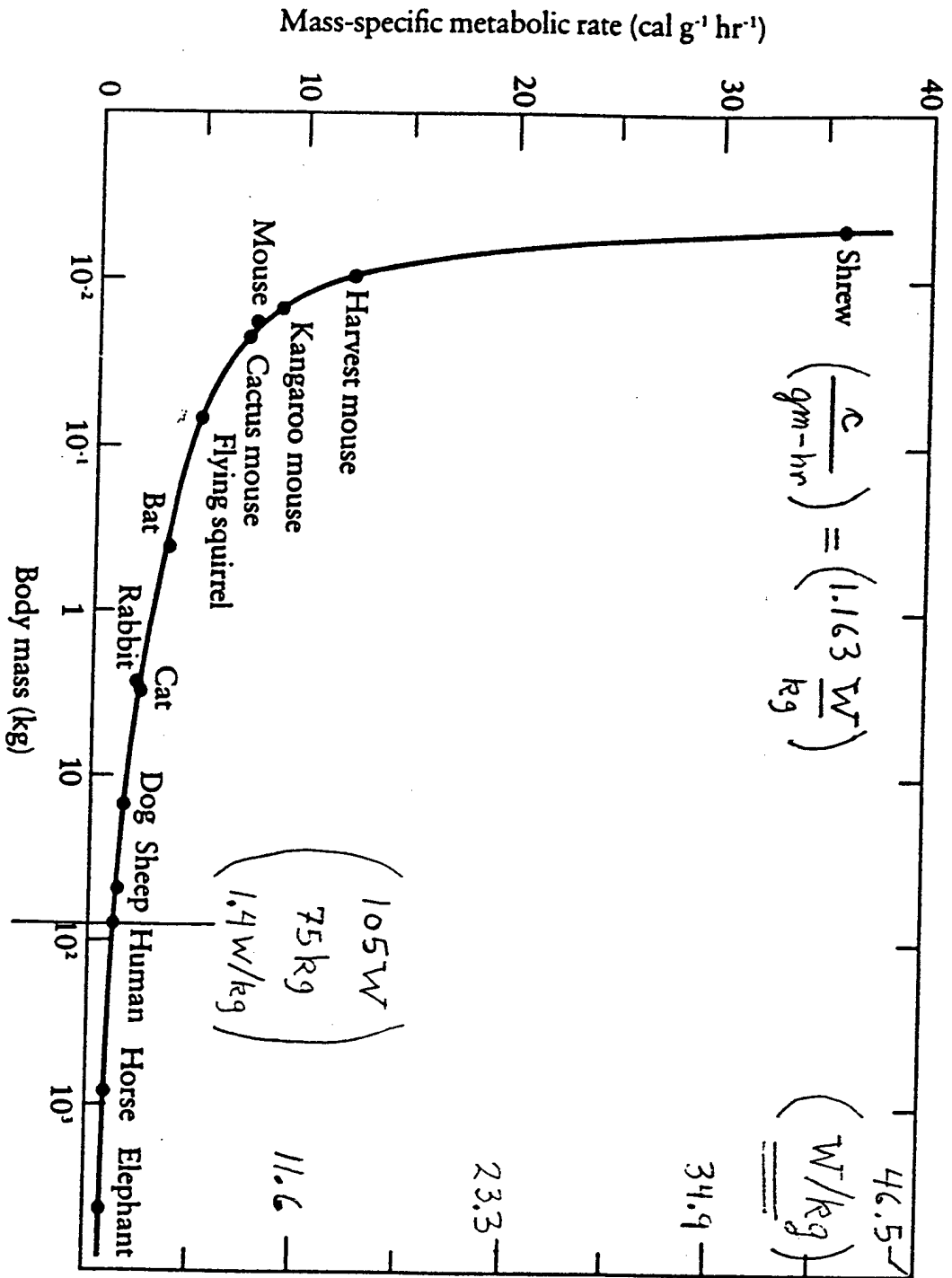

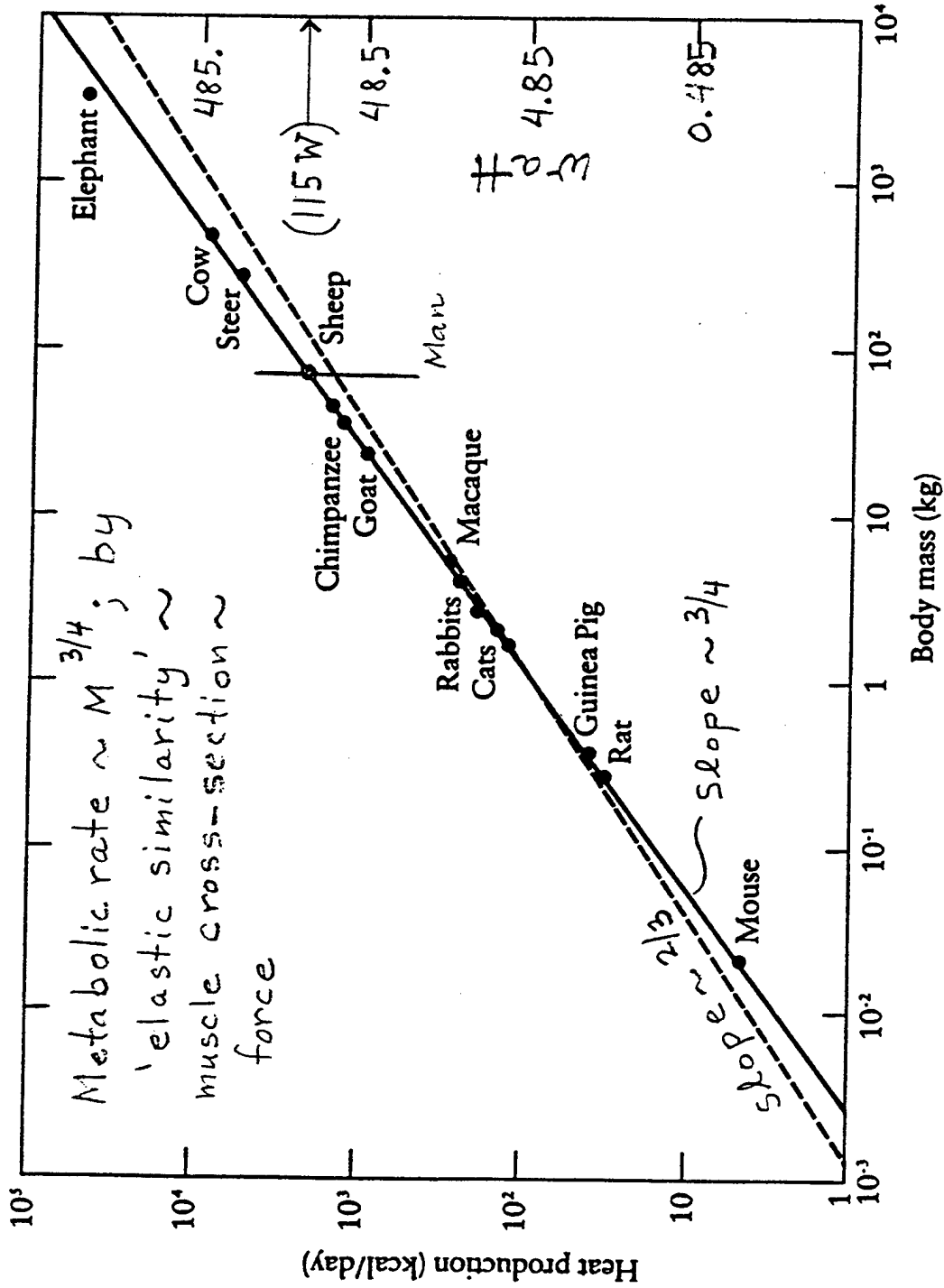

## ENERGY COST OF LATERAL LOCOMOTION

---

Creatures: Energy Cost = Metabolic rate/speed (J/kg-m)

Running mammals:  $E \sim 12.4 \bullet (\text{body mass})^{-0.40}$

Most of the energy goes into moving the limbs back and forth with respect to the body.

---

Helicopter	10 J/kg-m
Automobile	2
Man (72.6 kg)	2.2
Horse, Flyer (72.6 kg), Big jet	1
Swimmer (72.6 kg)	0.4
Long-distance freighter	0.1

---

Vertical (gravity) 9.81

Orbit (36MJ/kg; ht = 200 km) <180>

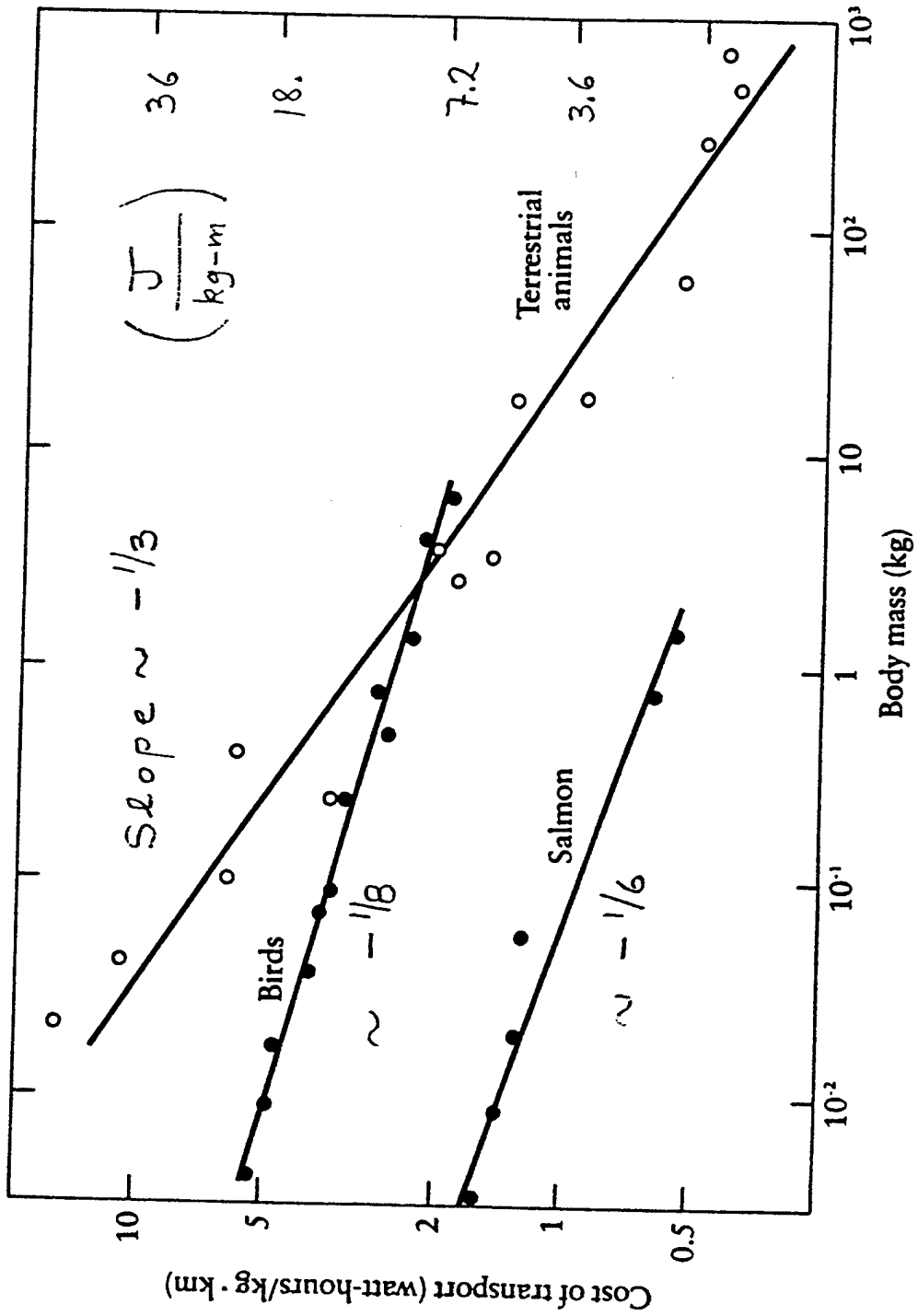

WHERE ARE

WE NOW?

# CONVERSION EFFICIENCIES

FROM ↓	TO →	Mechanical	Electrical	Light	Chemical	Thermal
Mechanical	-	-	99% elec. gen.	-	-	100% brake drum
Electrical	93% elec. motor	-	-	40% gas laser	72% battery	100% heating coil
Light	-	-	27% solar cell	-	0.6% photosyn.	100% solar furnace
Chemical	45% muscle	-	91% dry cell	15% chem. laser	-	88% steam furnace
Thermal	47% steam turbine	-	7% thermocouple	3% light bulb	-	-

# BATTERIES

## MECHANICAL SPRING

	Current SINGARS		Future	
	Primary	Secondary	Primary	Secondary
Energy Density (MJ/kg)	0.57 (LiSO <sub>2</sub> )	0.18 (Ni-metal hydride)	1.3 (Li/SOC1 <sub>2</sub> )	0.4 (Li-ion)
Volumetric Energy Density (MJ/l)	0.65 (LiSO <sub>2</sub> )	0.35 (Ni-metal hydride)	3 (Zn/air)	0.6 (Li-ion)
				0.013
				0.10

Existing SUO requirements

0 to 50 W on demand for 30 days

<5W>

10.8 MJ total

## RATIONS

Conditions	kcal/day	watt
Normal temperatures (T = 20°C to 30°C)		
<ul style="list-style-type: none"> <li>• Operational } Normal</li> <li>• Garrison }     </li> </ul>	3,600	175
• Restricted (≤ 10 days)	2,800	136
• Survival (≤ 4 days)	1,100 to 1,500	53 to 73
Hot environment (T ≥ 30°C) • Normal + 0.7% per kelvin above 30°C	400	19.4
Cold environment (T ≤ 14°C)		
• Normal + 5% + 2 to 5% for extra clothing		
• Arctic	4,500 to 5,000	218 to 242
• Climb Mt. Everest (8,000 kcal/day; alternate climb/rest)	16,000	775
Tour de France	7,000	339
BMR (1.17 W/kg)	1,640	80

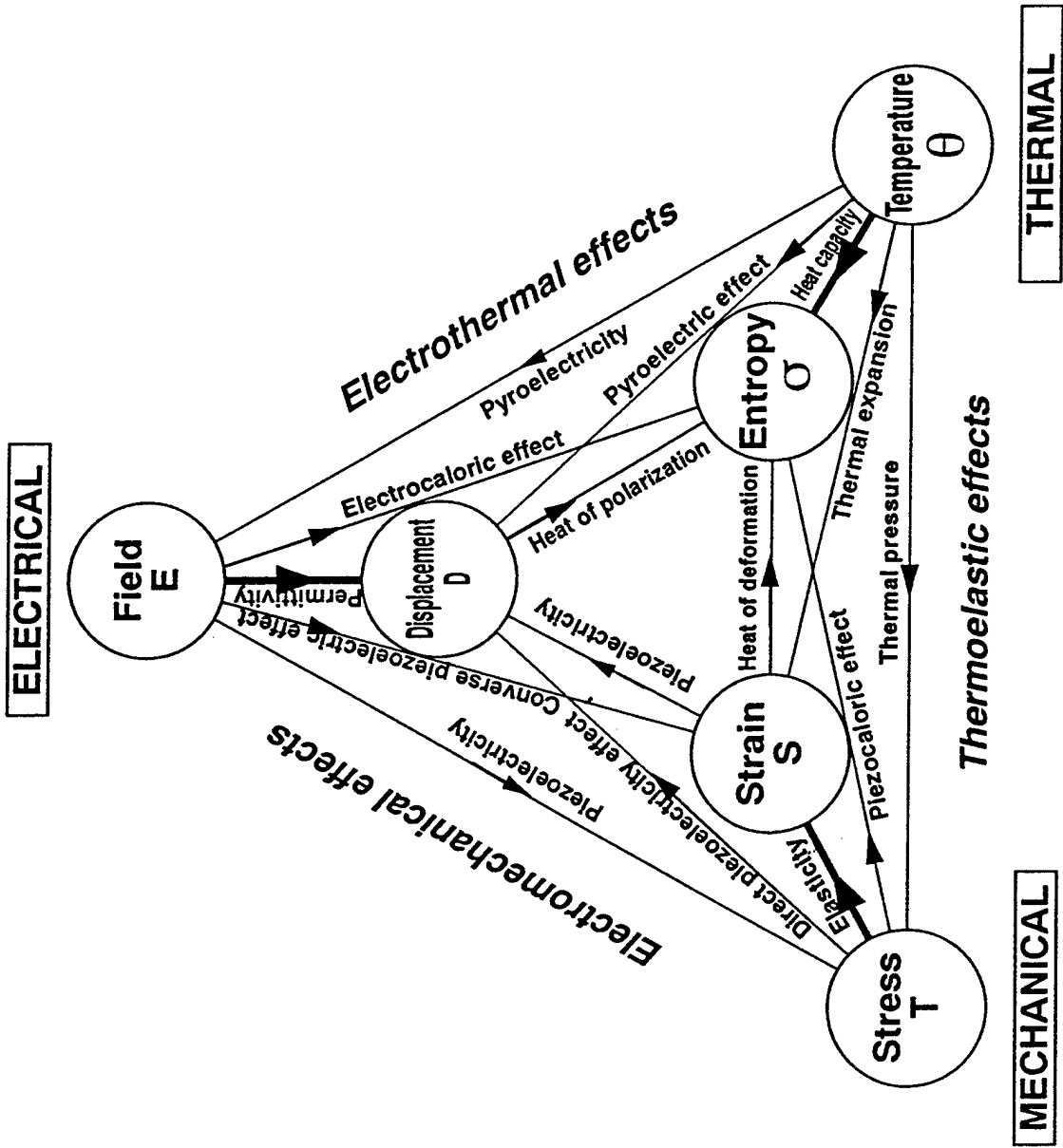

CRYSTAL SYSTEM	CENTRIC POINT GROUPS	ACENTRIC POINT GROUPS		OPTIC AXES		
		POLAR	NONPOLAR			
TRICLINIC	$\bar{1}$	1	NONE	B I A X I A L		
		2	NONE			
MONOCLINIC	$2/m$	m	NONE	B I A X I A L		
		mm2	222			
ORTHORHOMBIC	mmm	mm2	222	B I A X I A L		
		4	$\bar{4}$		$\bar{4}2m$	422
TETRAGONAL	$4/m$	4	4mm	$\bar{4}$	$\bar{4}2m$	422
TRIGONAL	$\bar{3}$	3	3m	32		U N I A X I A L
		6	6mm	$\bar{6}$	$\bar{6}m2$	
HEXAGONAL	$6/m$	6	6mm	$\bar{6}$	$\bar{6}m2$	622
		m3	NONE	23	$\bar{4}3m$	432
CUBIC	m3	NONE	NONE	23	$\bar{4}3m$	432
	11 GROUPS	10 GROUPS	11 GROUPS	11 GROUPS		ISO-TROPIC

GR623A/110593/#11/SP

# LINEAR ELASTOPIEZODIELECTRIC CONSTITUTIVE EQUATIONS

---

$$\mathbf{T} = \mathbf{c}^E \mathbf{S} - \mathbf{e} \mathbf{E}$$

$$\mathbf{D} = \mathbf{e} \mathbf{S} + \boldsymbol{\varepsilon}^S \mathbf{E}$$

$$\mathbf{S} = \mathbf{s}^E \mathbf{T} + \mathbf{d} \mathbf{E}$$

$$\mathbf{D} = \mathbf{d} \mathbf{T} + \boldsymbol{\varepsilon}^T \mathbf{E}$$

$$\mathbf{T} = \mathbf{c}^D \mathbf{S} - \mathbf{h} \mathbf{D}$$

$$\mathbf{E} = -\mathbf{h} \mathbf{S} + \boldsymbol{\beta}^S \mathbf{D}$$

$$\mathbf{S} = \mathbf{s}^D \mathbf{T} + \mathbf{g} \mathbf{D}$$

$$\mathbf{E} = -\mathbf{g} \mathbf{T} + \boldsymbol{\beta}^T \mathbf{D}$$

# PIEZOELECTRIC COUPLING COEFFICIENTS, K

---

Generic forms for  $k^2$ :

$$k^2 = d^2/(\epsilon s) = h^2/(\beta c) = e^2/(\epsilon c) = g^2/(\beta s)$$



# COMPARISON OF CERAMIC ACTUATOR TECHNOLOGIES

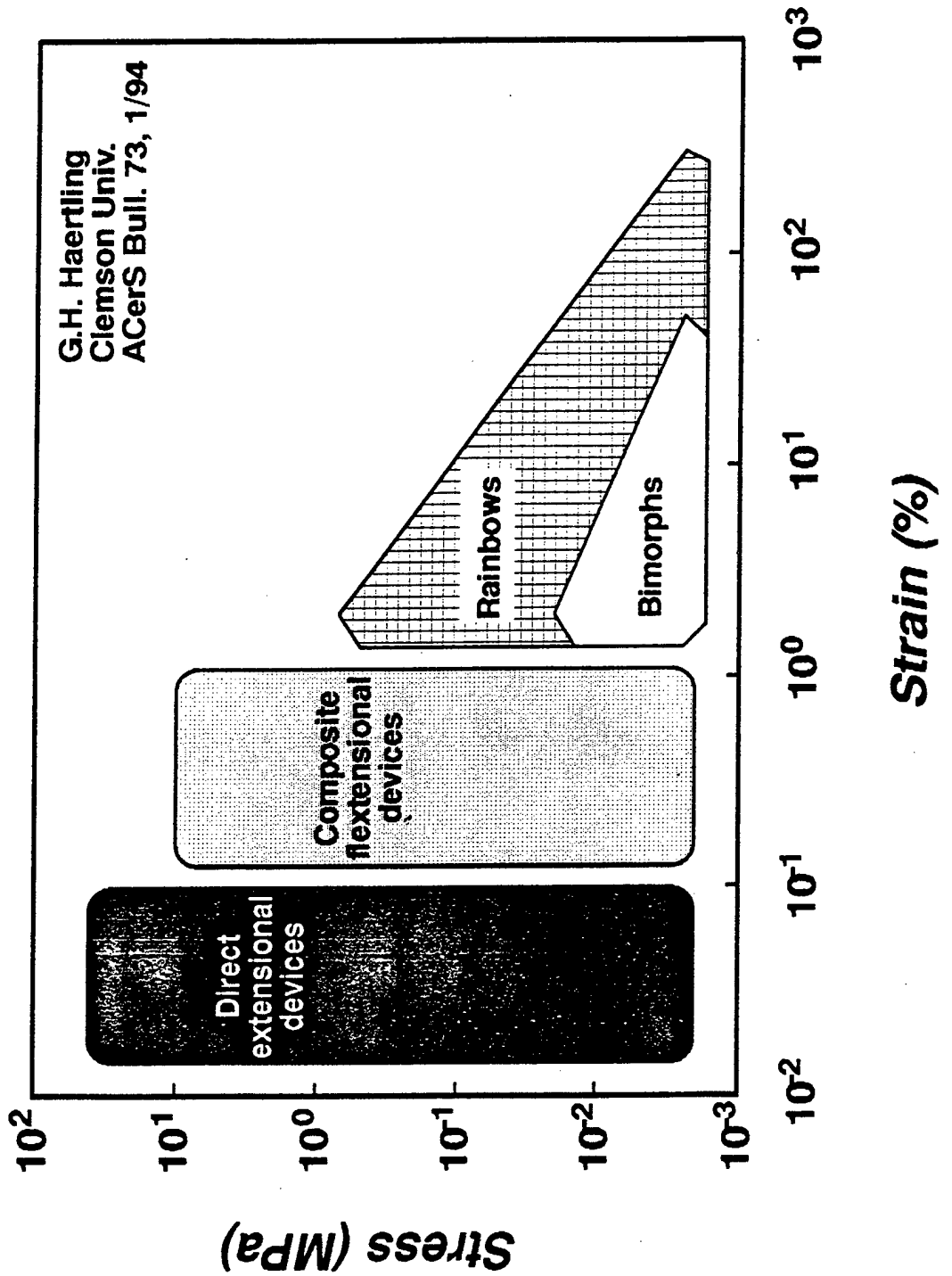

## ELECTRICAL & MECHANICAL VARIABLES

---

### QUANTITIES

voltage,  $V$

force,  $F$

charge,  $Q$

displacement,  $x$

current,  $I = \partial Q / \partial t$

velocity,  $v = \partial x / \partial t$

---

### PRODUCTS

$$\text{Energy} = V \bullet Q = F \bullet x$$

$$\text{Power} = V \bullet I = F \bullet v$$

### QUOTIENTS

$$\text{Elastance} = V / Q = F / x$$

$$\text{Impedance} = V / I = F / v$$



## MATCHING

---

• HUMANS: “soft”

small forces, large distances

• MATERIALS: “hard” (Piezoelectrics; springs, etc.)

large forces, small distances

## MAN AS SEEN BY ●●●

---

Physicist	$10^{23}$ atoms; Å scale
Chemist	electronic bonds (eV)
Biologist	$10^{11}$ - $10^{12}$ cells; $\mu\text{m}$ scale
●	
●	
●	
EE	neural net
Physiologist	walking creature; meter scale
	running creature
	lifting creature
	●●●
Cosmologist	$10^{-23}$ κοσμος; parsec scale
Poet	The Seven Ages of Man
Psalmist	What is Man, that Thou art mindful of him? 8:4

## MAN-SIZED UNITS

---

MASS  $m_m =$  1 - 10 kg (10 - 100 N force)

LENGTH  $l_m =$  0.001 - 1 m

TIME  $t_m =$  0.1 - 10 s

ENERGY  $E_m =$  0.01 - 100 J

VELOCITY  $v_m =$  0.01 - 10 m/s

POWER  $P_m =$  0.001 - 1000 W

Human ( $\rho \sim 1$ )  
 $7.5 \times 10^4 \text{ cm}^3$   
 $\sim 10^{13}$  cells

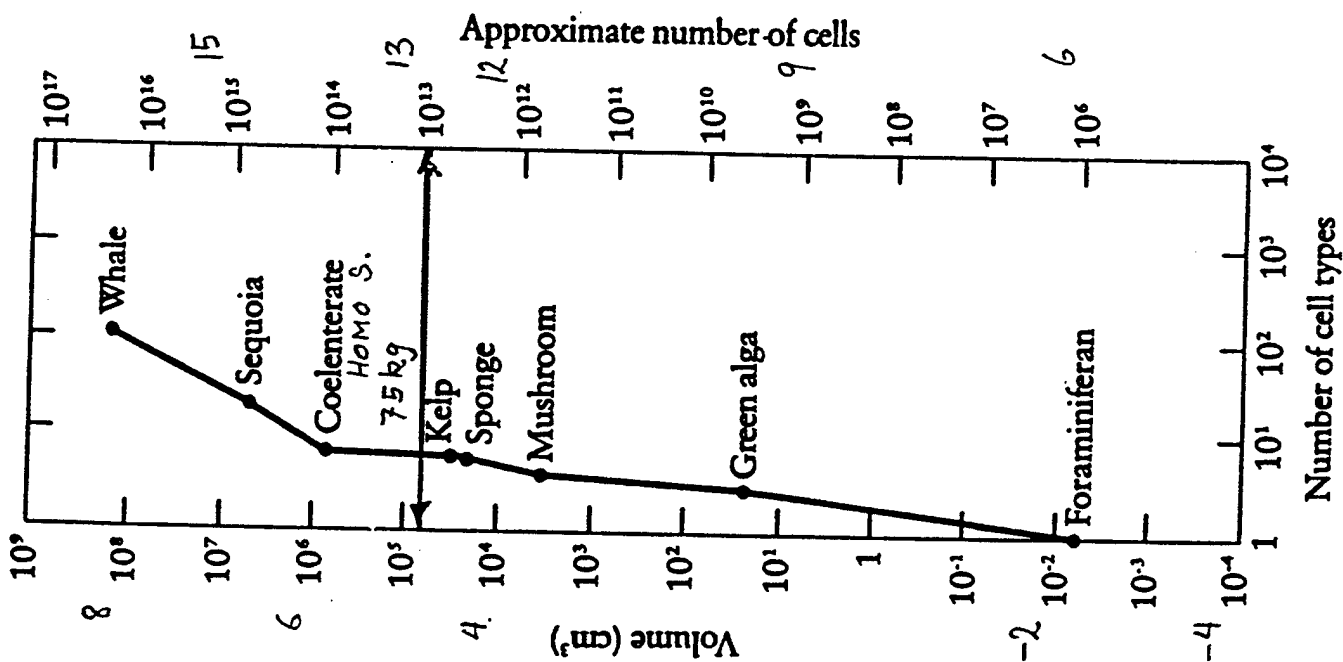

# CELLS

---

DC POWER	0
BIT	1
DATA	$10^3$
INFORMATION	$10^6$
KNOWLEDGE	$10^9$
UNDERSTANDING (?)	$10^{12}$
WISDOM (?)	$10^{15}$

## SUMMARY

---

- Generators/Storage - Hardware
  - Now: "single transistor" stage; poor impedance, elastance matches
  - Future: "IC; VLSI;" impedance, elastance matches
- "Piezo-power-pixels" embedded in micro-scale grid with intelligent accumulation/management
- Unobtrusive, casual generation, with 5 to 10 W output
  - "Fatigues without fatigue"
- Intelligent super-low-level electronics and power conserving software
- Software
  - Now: "ASIC" hardware, application specific
  - Future: "ASIC" software; software specifically crafted to the task

## REFERENCES

---

1. J. E. Allen, Aerodynamics, Harper and Row, New York, 1963.
2. K. Schmidt-Nielson, "Locomotion: energy cost of swimming, flying, and running," Science, Vol. 177, 21 July 1972, pp. 222-228.
3. T. A. McMahon and J. T. Bonner, On Size and Life, Scientific American Books, New York, 1983. [0-7167-5000-7]
4. Army Regulation 40-25, "Nutrition allowances, standards, and education," 15 May 1985.
5. B. W. Petley, The Fundamental Physical Constants and the Frontier of Measurement, Adam Hilger Ltd., Bristol, UK, 1985. [0-85274-427-7]
6. J. D. Barrow and F. J. Tipler, The Anthropic Cosmological Principle, Oxford University Press, New York, 1986. [0-19-851949-4]

## REFERENCES (continued)

---

7. H. C. Ohanian, Physics, 2<sup>nd</sup> ed., expanded. W. W. Norton & Co., New York, 1989. [0-393-95750-0]
8. J. H. McMasters, "The flight of the bumblebee and related myths of entomological engineering," American Scientist, Vol. 77, March-April, 1989, pp. 164-169.
9. J. L. Cook, Conversion Factors, Oxford University Press, Oxford 1991. [0-19-856349-3]
10. J. F. V. Vincent, Ed., Biomechanics - Materials, IRL Press Oxford, 1992. [0-19-963222-7]
11. A. Ballato, "Piezoelectricity: Old effect, new thrusts," IEEE Trans. Ultrasonics, Ferroelectrics, and Frequency Control, Vol. 42, No. 5, September 1995, pp. 916-926.
12. E. R. Cohen, The Physics Quick Reference Guide, AIP, New York, 1996. [1-56396-143-1]

## REFERENCES (continued)

---

13. T. Starner, "Human-powered wearable computing," IBM Systems J., Vol. 35, Nos. 3 & 4, 1996, pp. 618-629.
14. K. A. Hammond and J. Diamond, "Maximal sustained energy budgets in humans and animals," Nature, Vol.386, 3 April 1997, pp. 457-462.
15. M. I. Hoffert and S. D. Potter, "Beam it down. How the new satellites can power the world," Technology Review, Vol. 100, No. 7, October 1997, pp. 30-36.

The dimensional formulas for several physical variables.

	MLT (or MLT $\Theta$ )	FLT (or FLT $\Theta$ )
Length, $l$	[L]	[L]
Time, $t$	[T]	[T]
Force, $F$	[MLT $^{-2}$ ]	[F]
Area, $A$	[L $^2$ ]	[L $^2$ ]
Frequency, $f$	[T $^{-1}$ ]	[T $^{-1}$ ]
Mass, $m$	[M]	[FL $^{-1}$ T $^2$ ]
Velocity, $v$	[LT $^{-1}$ ]	[LT $^{-1}$ ]
Acceleration, $g$	[LT $^{-2}$ ]	[LT $^{-2}$ ]
Pressure, $P$ ; stress, $s$	[ML $^{-1}$ T $^{-2}$ ]	[FL $^{-2}$ ]
Energy (work), $\mathcal{E}$	[ML $^2$ T $^{-2}$ ]	[FL]
Dynamic viscosity, $\mu$	[ML $^{-1}$ T $^{-1}$ ]	[FL $^{-2}$ T]
Surface tension, $\mathcal{J}$	[MT $^{-2}$ ]	[FL $^{-1}$ ]
Mass density, $\rho$	[ML $^{-3}$ ]	[FL $^{-4}$ T $^2$ ]
Modulus of elasticity, $E$	[ML $^{-1}$ T $^{-2}$ ]	[FL $^{-2}$ ]
Specific heat at constant pressure, $C_p$	[L $^2$ T $^{-2}$ \Theta $^{-1}$ ]	[L $^2$ T $^{-2}$ \Theta $^{-1}$ ]
Thermal conductivity, $k$	[MLT $^{-3}$ \Theta $^{-1}$ ]	[FT $^{-1}$ \Theta $^{-1}$ ]

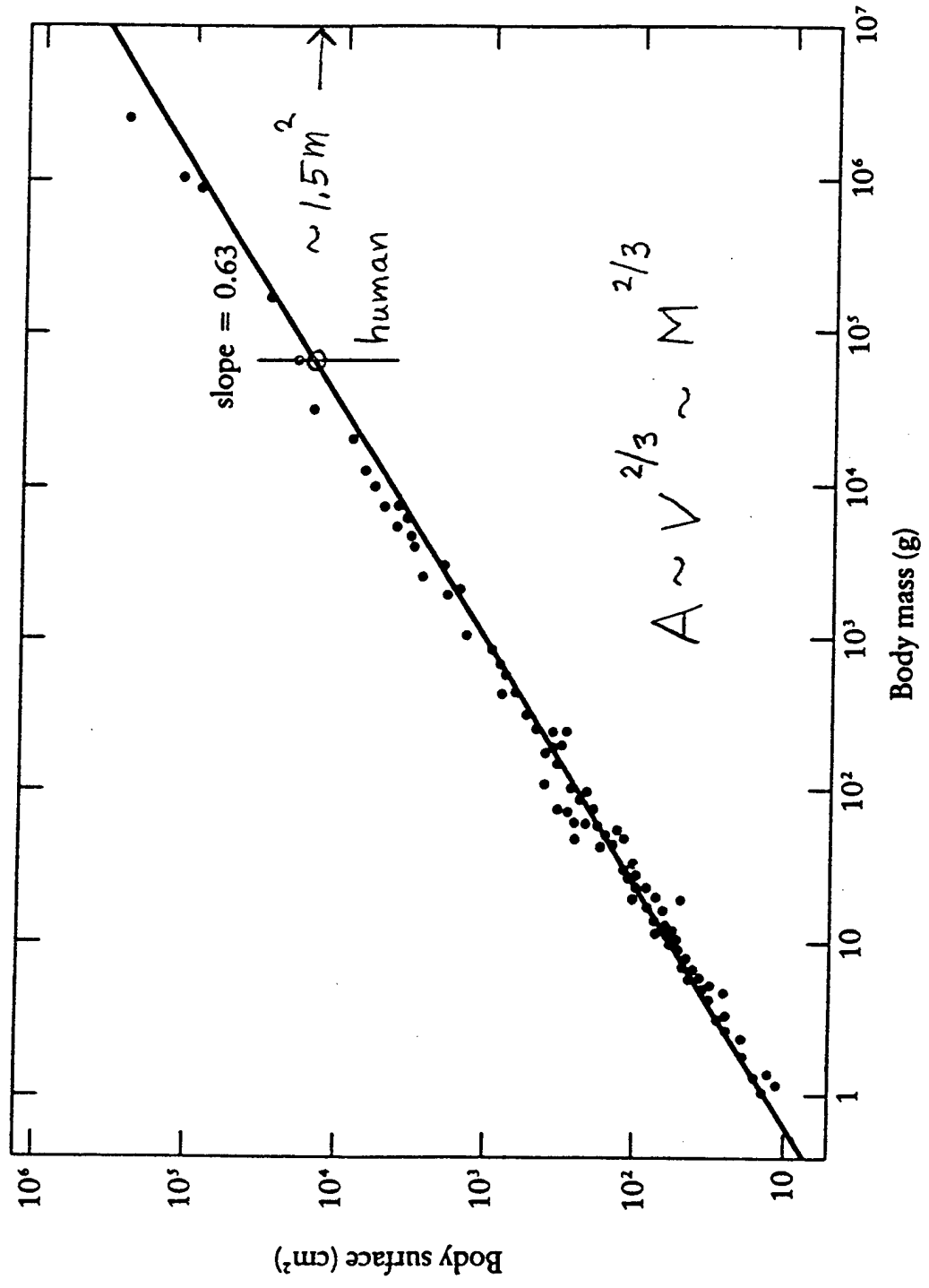

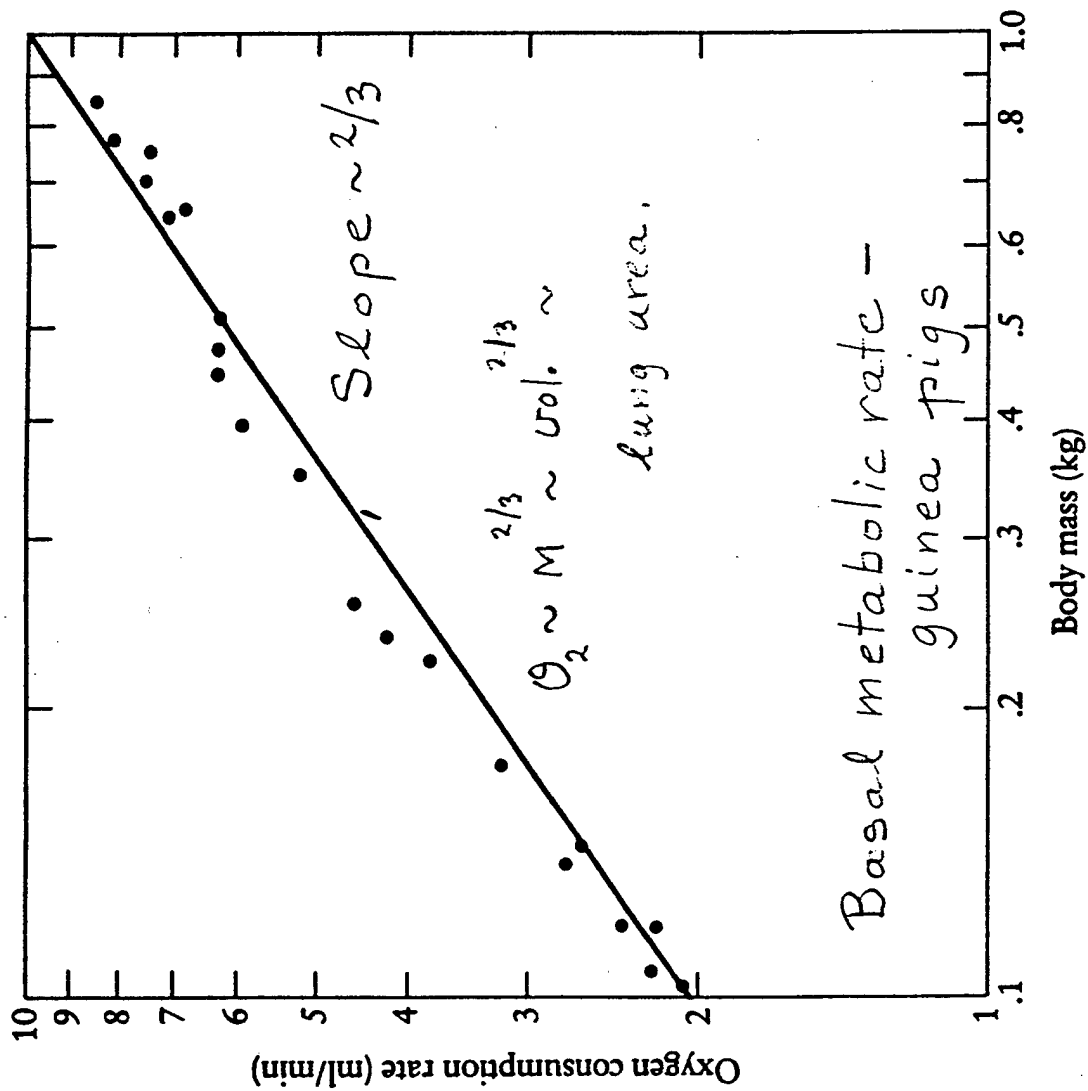

**“HISTORY AND STATUS OF PERSONAL POWER DEVICES  
FOR THE COMMERCIAL MARKET”**

**Mr. John Hutchinson**

**Baygen  
Constanta, South Africa 7800**

## SYNOPSIS : SPRING POWERED DEVICES

The BayGen® Group was established in 1994 to develop and exploit the concept of Personal Power Generation (PPG) and its current products include radios and a flashlight. A PPG system enables human mechanical energy to be stored indefinitely and without decay. It delivers this energy in electrical form, upon demand, and in controllable fashion. PPG units may be integral with the power consuming device, as in the Freeplay® radio and flashlight, or they may be as separate packs designed for emergency or every day power sources for devices like telephones, navigating aids and radio/cassette players. So far BayGen® has confined its efforts to PPG systems where the human input is intentional and not incidental.

Present Baygen® products use strip steel springs as the primary storage device. These springs are configured in a constant force (negator) arrangement. The steel spring is energised by winding it from one spool to another against the pre-form. As the spring returns to its original position it applies a rotational torque to a transmission, whose output drives a direct current generator. This produces between 0.1w and 1.5w of power. Constant force springs offer excellent ergonomic power absorption qualities, they may be wound up slowly or very fast. Because electrical power is generated relatively slowly electromechanical losses are minimized. All-gear transmissions can be noisy in certain applications (e.g. radio), and to alleviate this a flexible drive may be used in the last stage.

Only the amount of work actually exerted by the user, less an allowance for inefficiencies, may be redelivered. PPG systems are therefore more limited by human capacity than by technology. Input mechanisms should provide for the most comfortable and ergonomically efficient acceptance of human mechanical energy. By extending the human fatigue point, larger amounts of energy may be delivered to and stored by the system. A 60-turn spring stores approximately 500 joules of mechanical energy. Current systems have an overall efficiency of approximately 40% and about 200 joules electrical are delivered.

Although negator springs have constant force characteristics they do not provide constant torque. Torque decays to about 75% of initial value during the unwind cycle. In order to produce constant power a regulation device is necessary. BayGen® has developed and uses various designs. These include interim or buffer storage devices using a capacitor or a rechargeable battery. With suitable power regulation, spring based systems are able to power a wide range of electronic products.



**BAYGEN®  
FREEPLAY® RADIO II**

**Introduction**

The Freeplay® Radio utilises personally generated power, and has no need for batteries or an external power source. The energy storage and release mechanism is based upon energising a textured carbon steel spring by winding it from one spool to another. As the spring returns to its original position, it releases it's energy and applies a rotational torque into a transmission. The transmission consists of a three stage gearbox, which speeds up the input rotation by a factor of 1:1000. The transmission output drives a direct current generator which produces up to 100mW of power. This is used as the energy for a radio receiver. The structural components for the Freeplay® Radio consist of injection mouldings made from a number of different materials. Other components include the carbon steel spring, electronics, PC board, switches, fasteners, etc. The injection moulded components require original tooling.

**Specifications**

<i>Power Source: Internal</i>	B-Motor textured carbon steel spring, 10m x 50mm x 0,2mm, driving a DC generator through a transmission. 60 Winds provides full energy storage.
<i>Power Source: External</i>	Optional DC adaptor (centre positive) 3V-12VDC/200mA.
<i>Spring Saver:</i>	This circuit allows playtimes of up to 60 minutes at low volumes. At low power demand, this device stores generated energy not required by the radio in a capacitor. A control circuit regulates the motor/capacitor duty cycle and results in a lower unwind rate.
<i>Frequency Range:</i>	FM 88 – 108MHz AM 500 – 1700KHz
<i>Generator:</i>	Mabuchi RF-500TB D.C. motor "in reverse", producing 35mA, 3V at 1500 r.p.m.
<i>Speaker:</i>	Size 4 inch Impedance 8 ohms Output 5W (Max)
<i>Antenna System:</i>	FM Telescopic Antenna AM Built-in Ferrite Bar Antenna
<i>Dimensions:</i>	Height 200mm Width 200mm Length 290mm Weight 2,4kg

# FREEPLAY™ FLASHLIGHT

The **Freeplay**® flashlight is designed to be the last flashlight a user ever needs to buy. It operates independent of any commercial electricity source yet it has the ability to use such sources if available.

The **Freeplay**® flashlight works by using human energy stored in a spring or by a rechargeable battery.

## SPRING POWER OPERATION

- A winding handle energizes a constant force spring. Sixty turns of the handle, taking 20–30 seconds, fully energizes this spring.
- Spring energy may be used to power the bulb directly, or to charge the battery. When used to charge the battery consecutive spring discharge cycles may be dumped into the battery to increase its charge level.
- One spring discharge provides four minutes of shine time. Multiple spring discharges into the battery allows extended continuous shine times.
- The spring may be stored indefinitely in the wound condition. This allows instantaneous flashlight operation whenever required.
- The flashlight may be operated directly off the spring even when the battery is flat.
- The spring lifetime is 10,000 full wind/discharge cycles, after which its storage capacity degrades gradually.
- The spring is equipped with a mechanical brake. If the flashlight is switched off before the spring is fully discharged any wind still on the spring is preserved.

## BATTERY OPERATION

- The flashlight is equipped with a rechargeable battery.
- The battery is charged either by one or more spring discharges, or by a mains adapter. Each spring discharge provides four minutes of shine time and a full mains charge gives two hours of shine time.
- This high specification battery has a lifetime of 5 - 10 years, which may be exceeded if operating instructions are followed. Should it be necessary to replace the battery the user easily does this.
- The battery is recyclable and carries the RBRC battery recycling licence and seal.

## FEATURES

- 60 Turn spring.
- Hi impact ABS casing and rugged constitution.
- Water resistant sealing.
- Flasher function.
- High efficiency 2,3V 350mA bulb.
- Spare bulb.
- Patented HI GAIN® lens.
- D.C. input socket.
- Mains adaptor (supplied)
- Car adaptor (optional).
- Solar charger (optional).
- Weight 1,8 kg.
- Dimensions 240 x 160 x 120 mm.

## DESIGN CONFIGURATION

### STANDARD VERSION

- First production models feature the flashlight as a single unit.
- The rechargeable battery, PCB and switches are housed in the body of the flashlight, and operation is as per a regular lantern.

### UPGRADED VERSION

- An upgraded version which features a detachable lens assembly is scheduled for later production.
- The rechargeable battery, PCB and switches are housed in a detachable front unit which may be removed from the main body containing the spring engine.
- This unit operates independently as a mini flashlight under battery power.
- The battery compartment pivots to provide a handle.
- To charge the batteries from mains power or by spring discharge the detachable unit is remounted onto the main body.
- When attached, the flashlight operates similarly to the standard version from either spring or battery power.

# Freeplay® Radio Cutaway

ANTENNA

ON/OFF SWITCH

END STOP

TORQUE SPOOL

FOLD AWAY HANDLE

PC BOARD

GENERATOR

DRIVE BELT

SPEAKER

POWER TRANSMISSION

STORAGE SPOOL

SPRING

DRIVE PULLEY

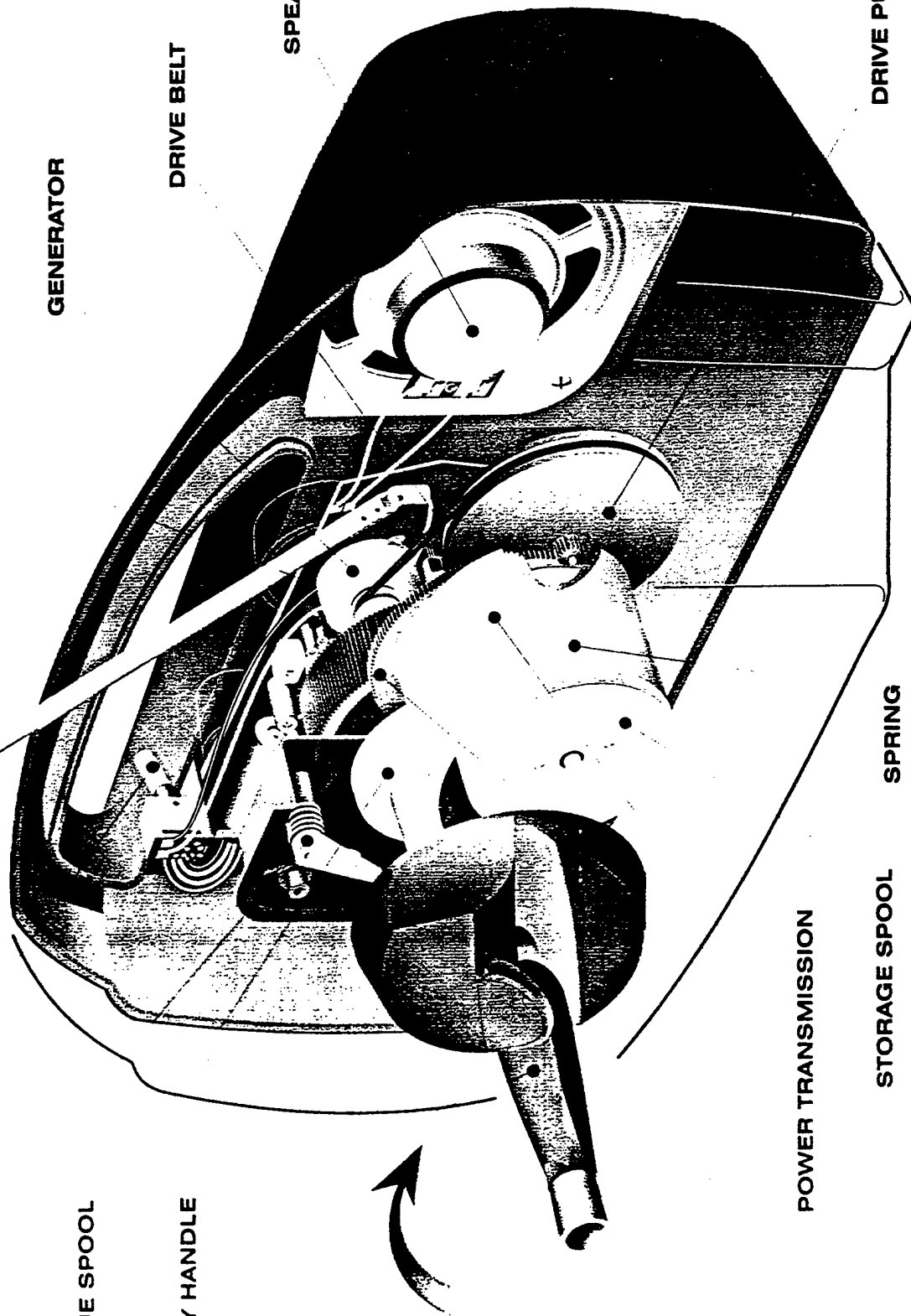

# Freeplay Radio Cutaway

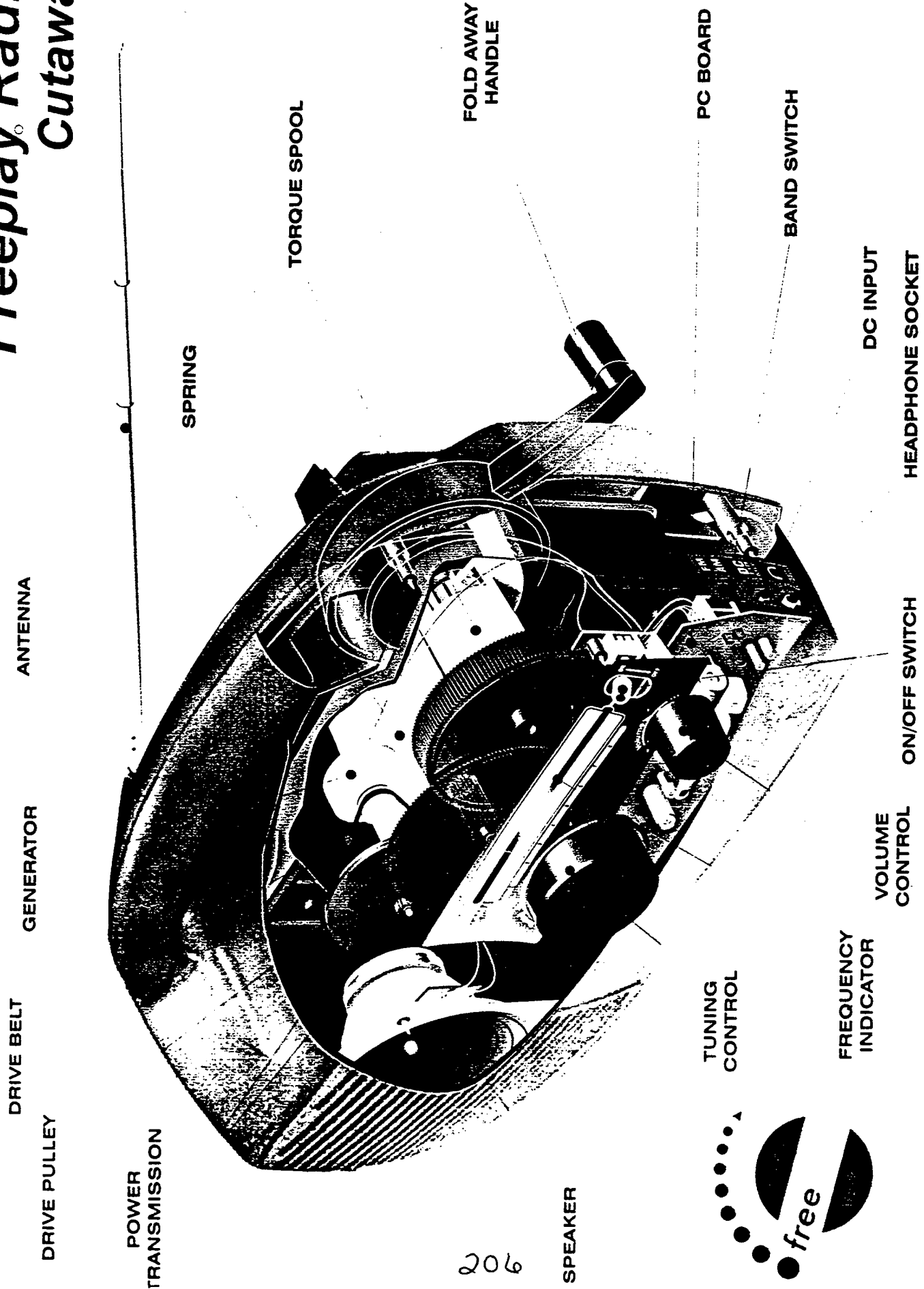

DRIVE BELT

GENERATOR

ANTENNA

SPRING

TORQUE SPOOL

FOLD AWAY HANDLE

PC BOARD

BAND SWITCH

DC INPUT

HEADPHONE SOCKET

ON/OFF SWITCH

VOLUME CONTROL

TUNING CONTROL

FREQUENCY INDICATOR

DRIVE PULLEY

POWER TRANSMISSION

SPEAKER

206



# Freeplay® Flashlight



# Freeplay® Flashlight Cutaway

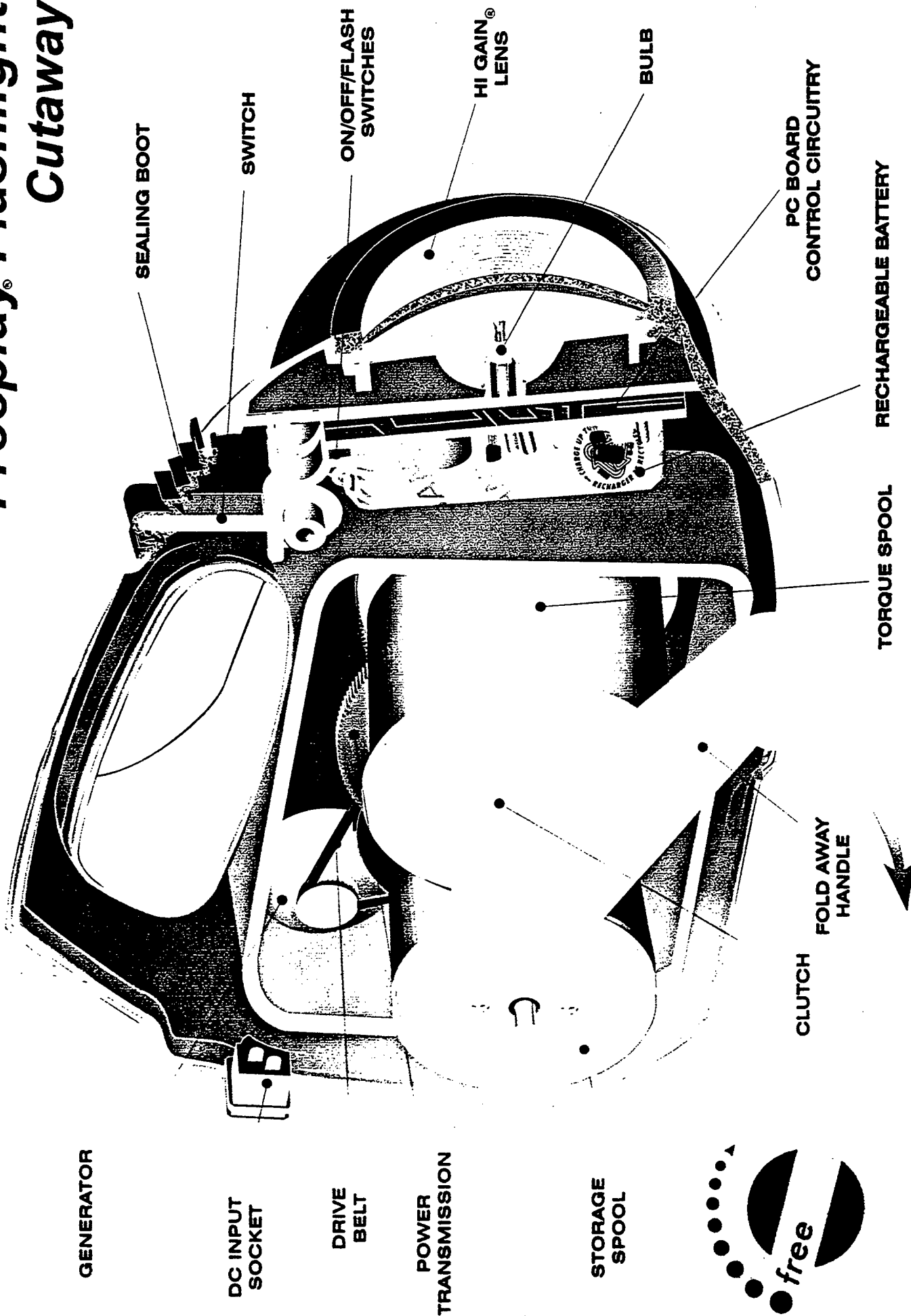

GENERATOR

DC INPUT  
SOCKET

DRIVE  
BELT

POWER  
TRANSMISSION

STORAGE  
SPOOL



CLUTCH

FOLD AWAY  
HANDLE

SEALING BOOT

SWITCH

ON/OFF/FLASH  
SWITCHES

HI GAIN®  
LENS

BULB

PC BOARD  
CONTROL CIRCUITRY

RECHARGEABLE BATTERY

TORQUE SPOOL

**Freeplay Flashlight**  
**Detachable Lens Version**



# Freeplay® Flashlight Detachable Lens Version Detailed Cutaway

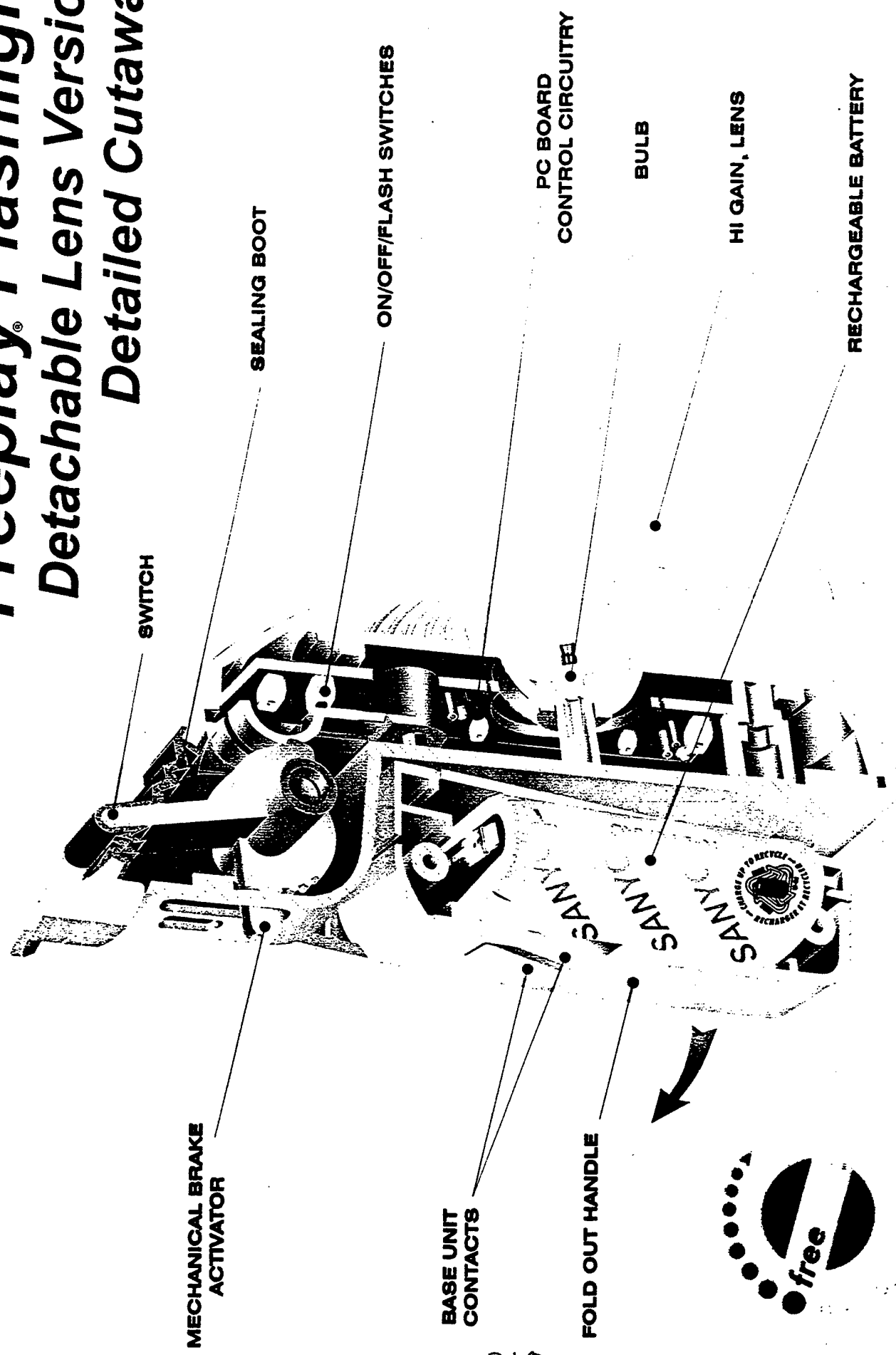

SWITCH

SEALING BOOT

ON/OFF/FLASH SWITCHES

PC BOARD  
CONTROL CIRCUITRY

BULB

HI GAIN, LENS

RECHARGEABLE BATTERY

MECHANICAL BRAKE  
ACTIVATOR

BASE UNIT  
CONTACTS

FOLD OUT HANDLE



**“PHYSIOLOGICAL FACTORS THAT MAY LIMIT AND  
TECHNIQUES THAT MAY ENHANCE HUMAN  
PERFORMANCE”**

**Dr. Ellen L. Glickman-Weiss**

**Kent State University  
Kent, OH 44242**

# **PHYSIOLOGICAL FACTORS THAT MAY LIMIT AND TECHNIQUES THAT MAY ENHANCE HUMAN PERFORMANCE**

**E. Glickman-Weiss PhD, FACSM**

**Exercise Sciences Laboratory  
Kent State University  
Kent, Ohio**



## **VO<sub>2</sub>max (maximum oxygen consumption)**

**“The region where oxygen uptake plateaus and shows no further increase, or increases slightly, with an additional workload”**

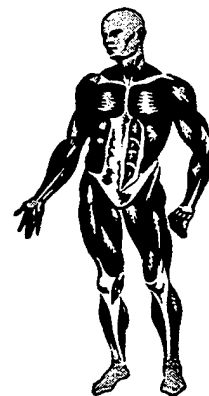

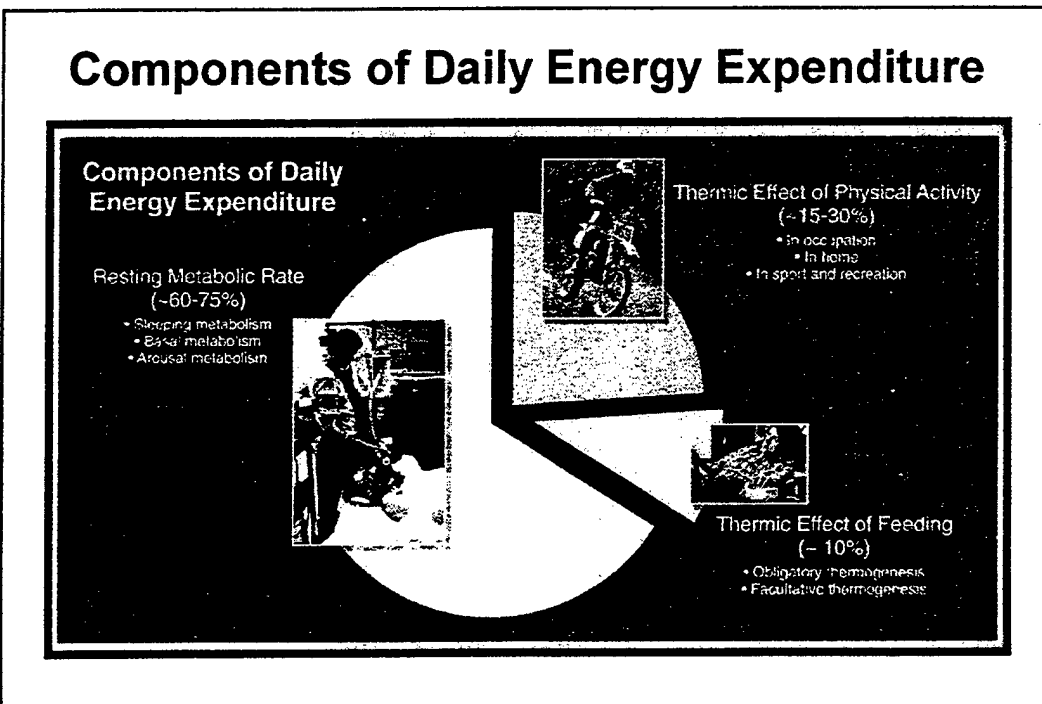
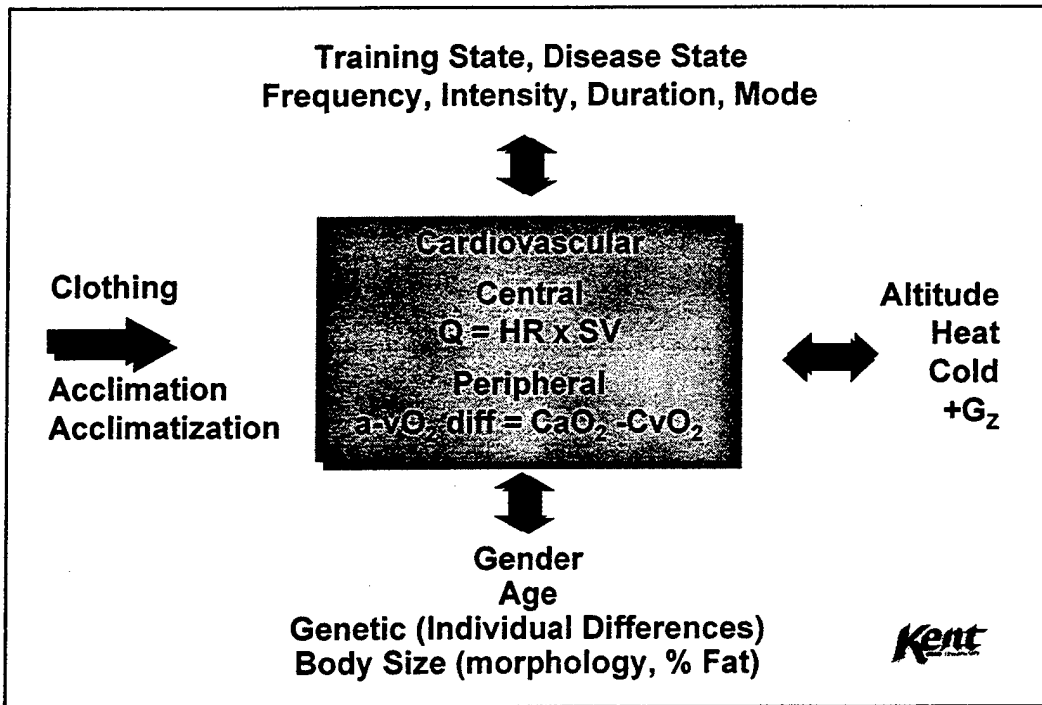

**“Maximum capacity to take in room air and distribute it to the working skeletal muscles”**

**Kent**



## Determining Energy Expenditure of Specific Activities

Portable Spirometry



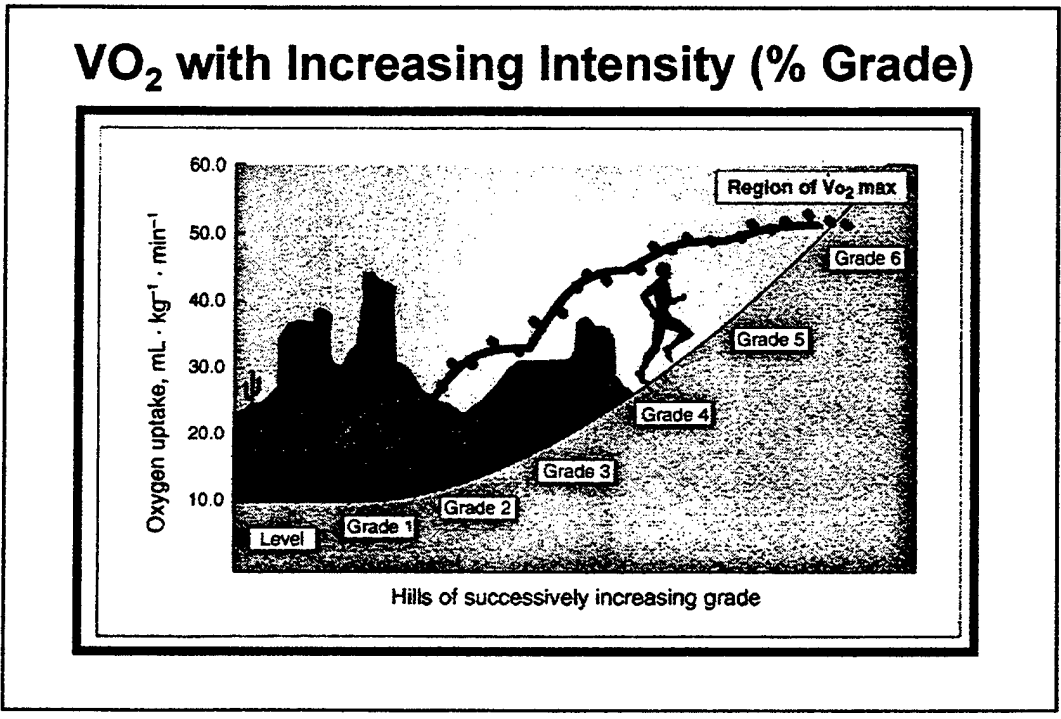



## Treadmill Protocols to Measure VO<sub>2</sub>max

- Naughton Test
- Astrand Test
- Bruce Test
- Balke Test
- Ellestad Test
- Harbor Test

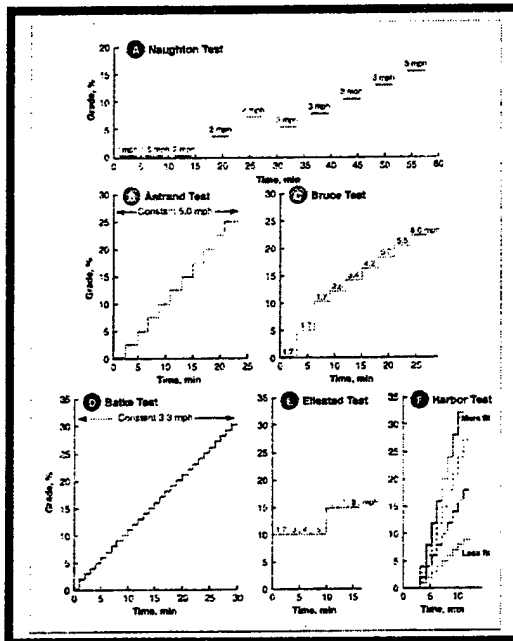
**Kent**



## Fick Principle

Measurement of cardiac output

$$VO_2 = Q \cdot a-vO_2 \text{ diff}$$

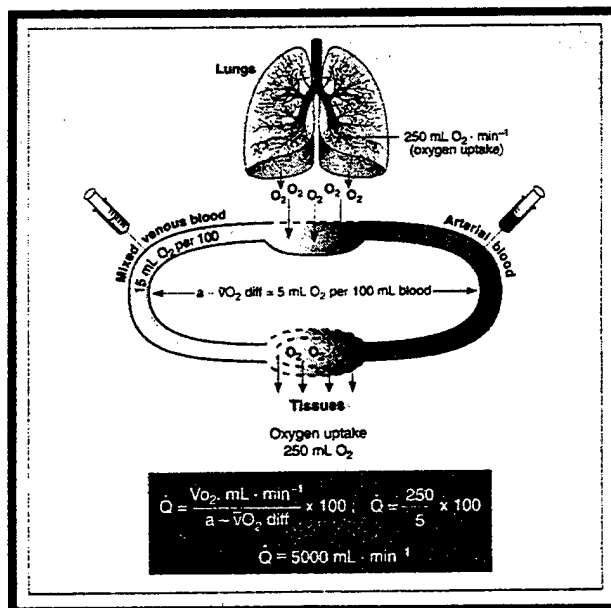

**Kent**

## Cardiovascular Variables

- **Cardiac Output ( $\text{mL}\cdot\text{min}^{-1}$ )**
  - The amount of blood pumped by the heart per minute
- **Stroke Volume (mL)**
  - Quantity of blood ejected from the heart with each stroke
- **Heart Rate ( $\text{beats}\cdot\text{min}^{-1}$ )**
  - Rate of pumping

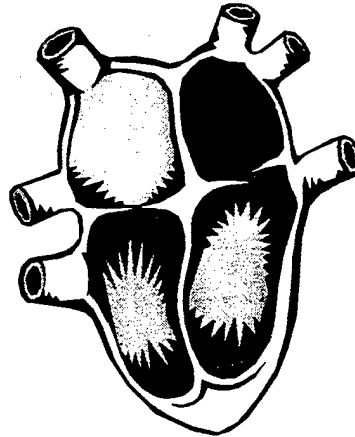

**Kent**

## Cardiac Output Distribution

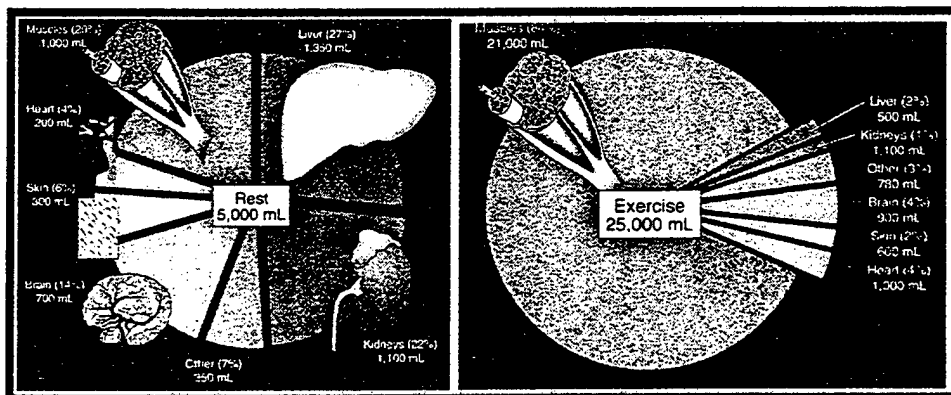

**Kent**

## Cardiovascular Variables and Training

$$\text{Cardiac Output} = \text{HR} \times \text{SV}$$

### Rest

Untrained	5000 mL·min <sup>-1</sup>	70 beats·min <sup>-1</sup>	71 mL
Trained	5000 mL·min <sup>-1</sup>	50 beats·min <sup>-1</sup>	100 mL

### Maximal Exercise

Untrained	22000 mL·min <sup>-1</sup>	195 beats·min <sup>-1</sup>	113 mL
Trained	35000 mL·min <sup>-1</sup>	195 beats·min <sup>-1</sup>	179 mL

**KENT**

## Stroke Volume vs VO<sub>2</sub>

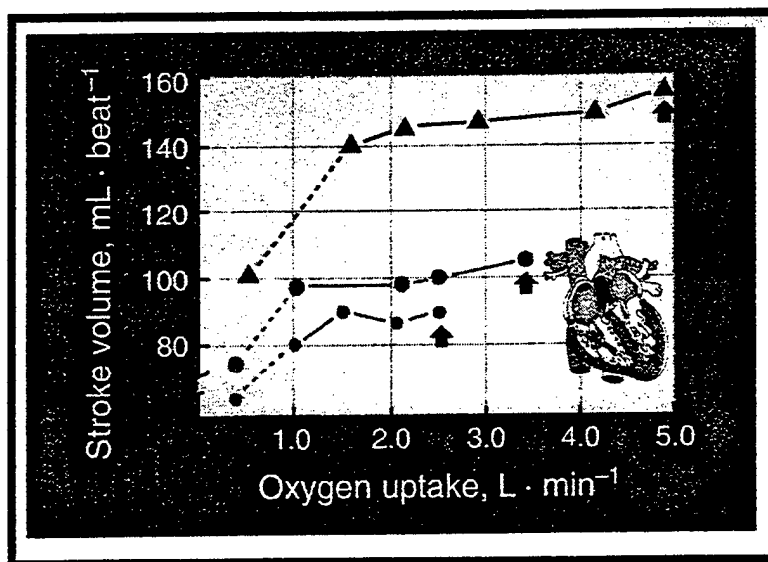

▲  
Endurance  
athletes

●  
College students  
before 55 days  
training

●  
College students  
after 55 days  
training

**KENT**

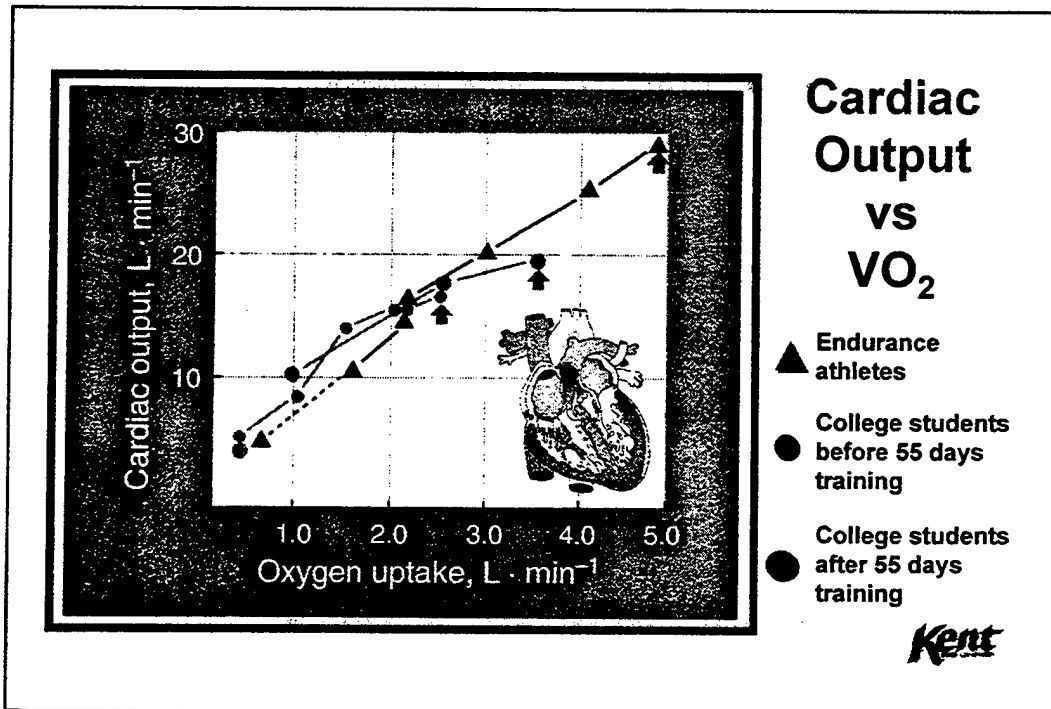
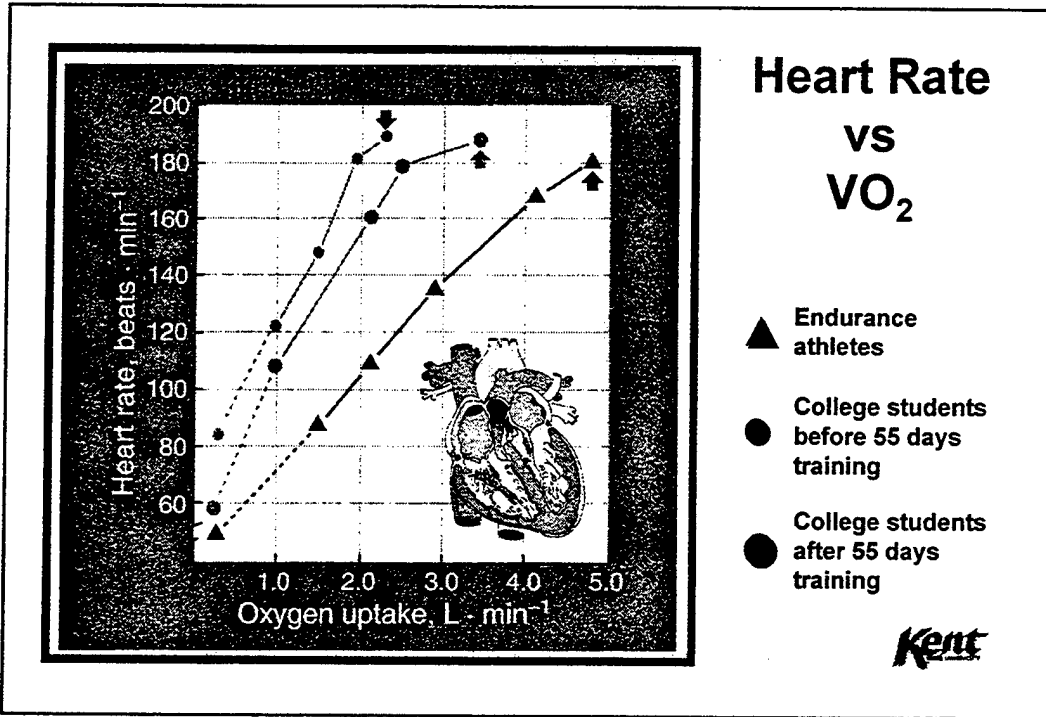

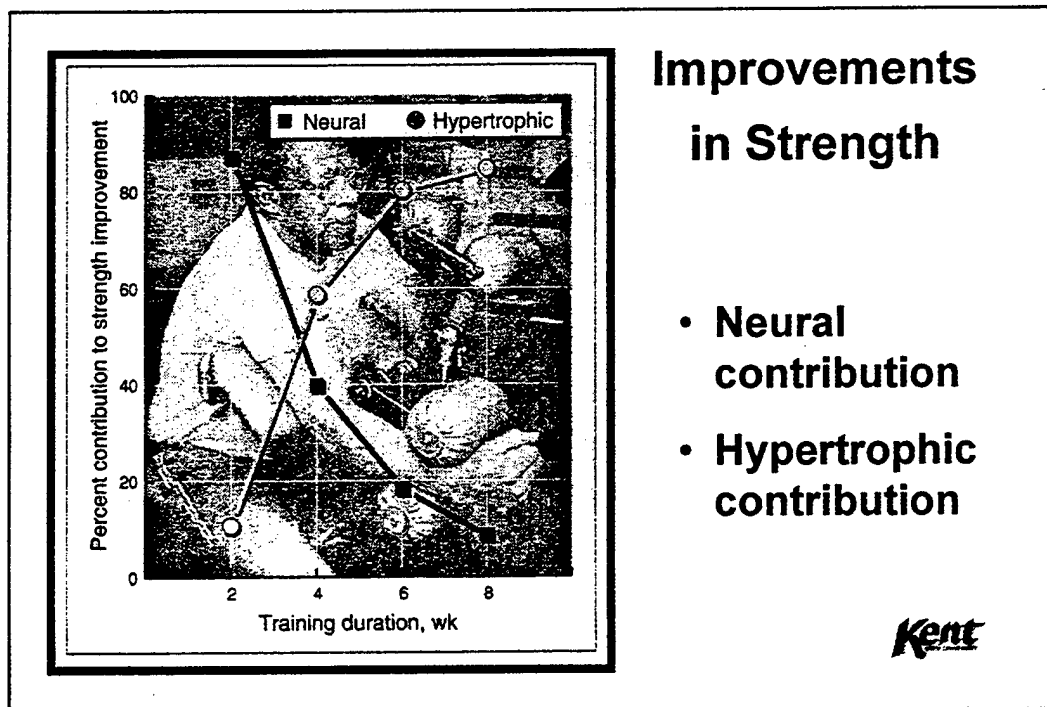
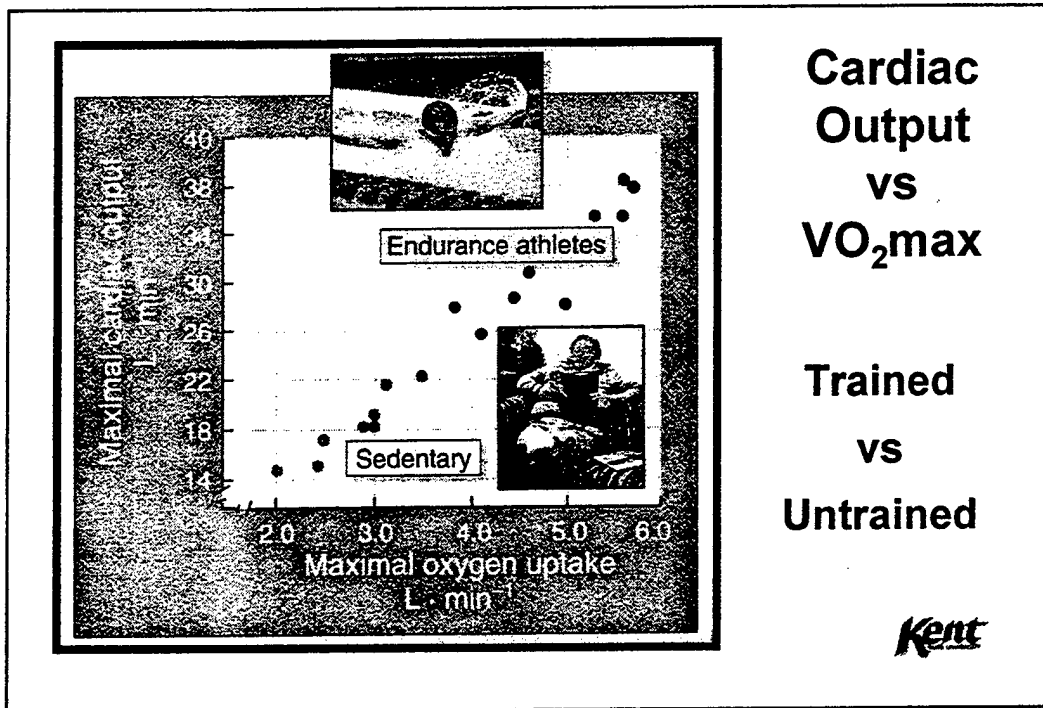

## Factors Determining Muscle Mass

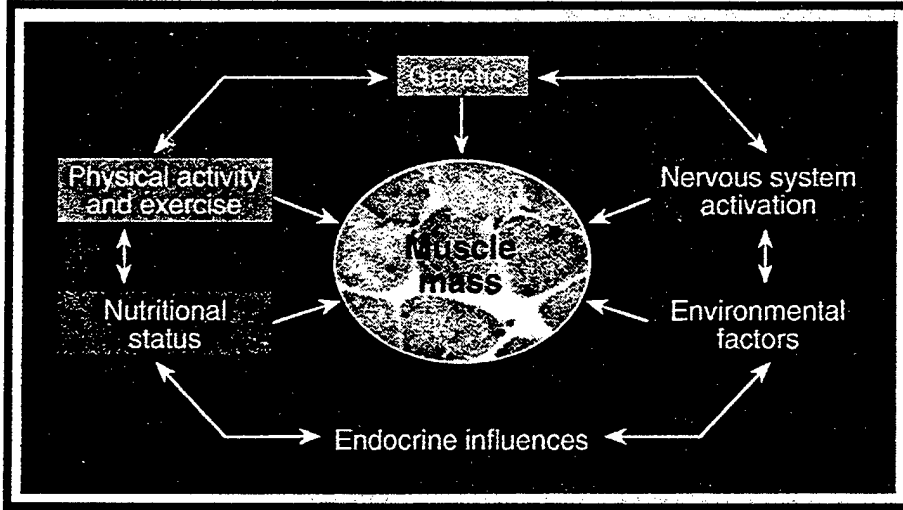

## a-vO<sub>2</sub> difference vs VO<sub>2</sub>

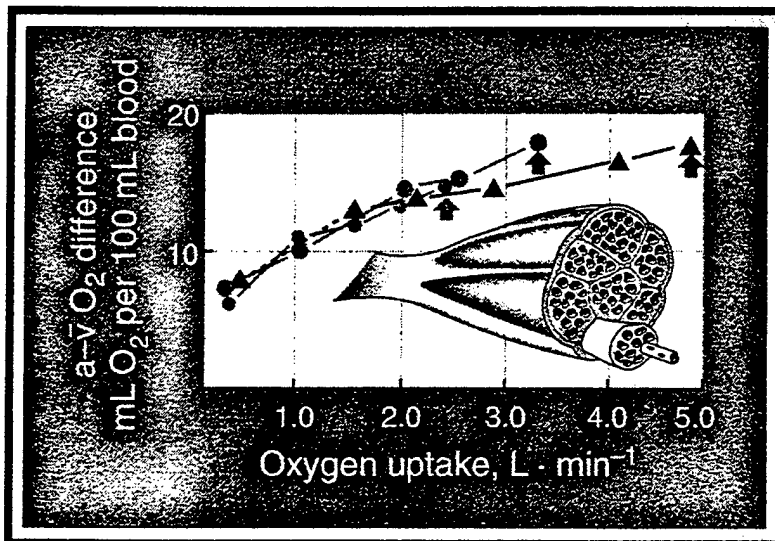

▲  
Endurance athletes

●  
College students before 55 days training

●  
College students after 55 days training

**Kent**

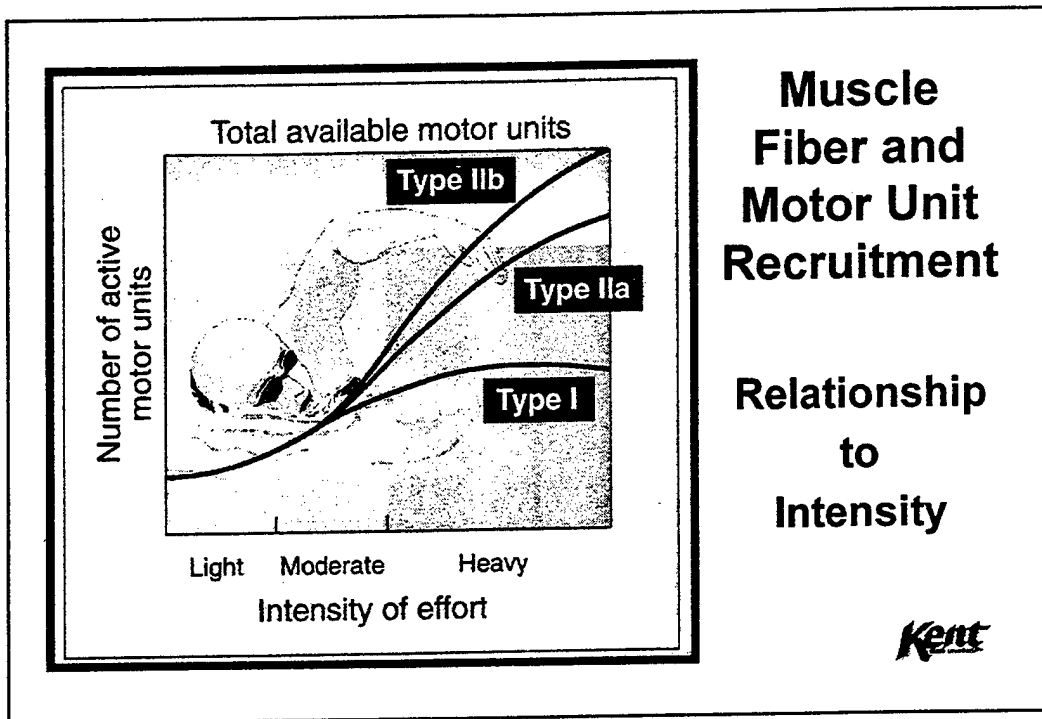

**Specificity**

**“A principle of training that the adaptation of a tissue is dependent on the type of training undertaken”**

*Kent*

The illustrations show a sprinter in a starting crouch on the left and a cyclist in a racing position on the right, representing different types of physical training.

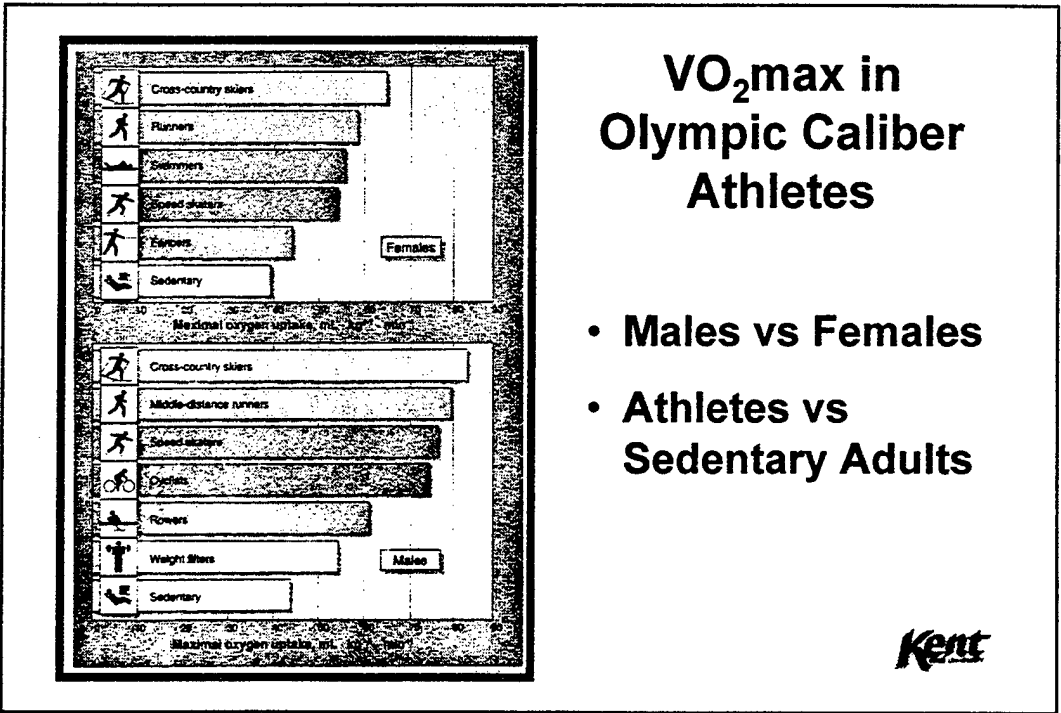
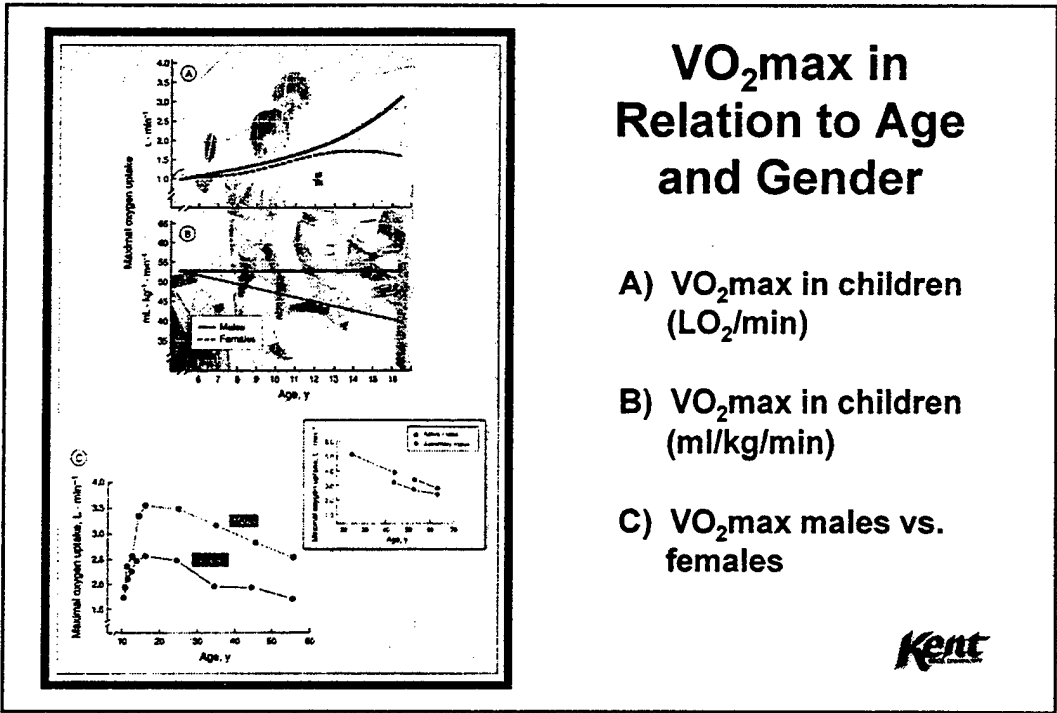

## VO<sub>2</sub>: Arm vs Leg Exercise

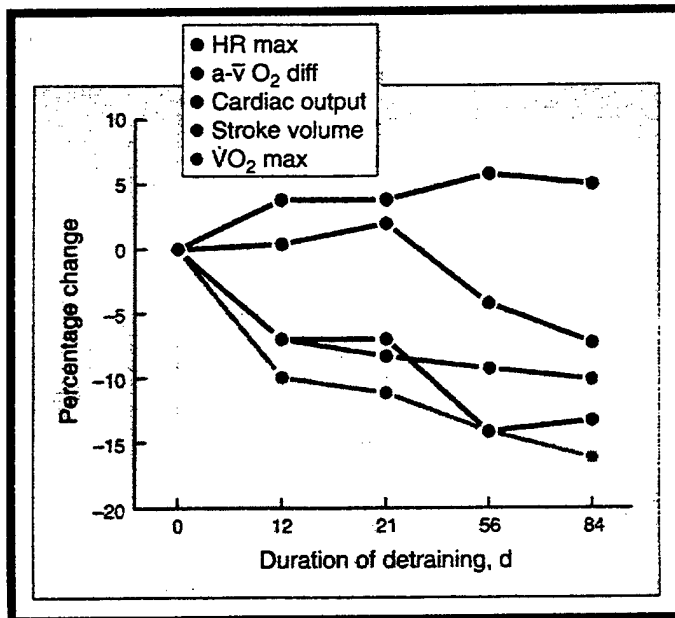
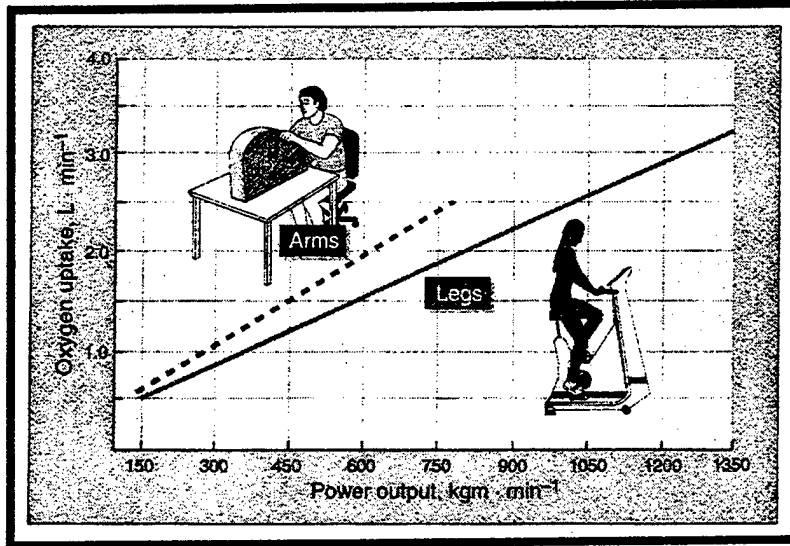

## Effects of Detraining

Cardiovascular Responses

**Kent**

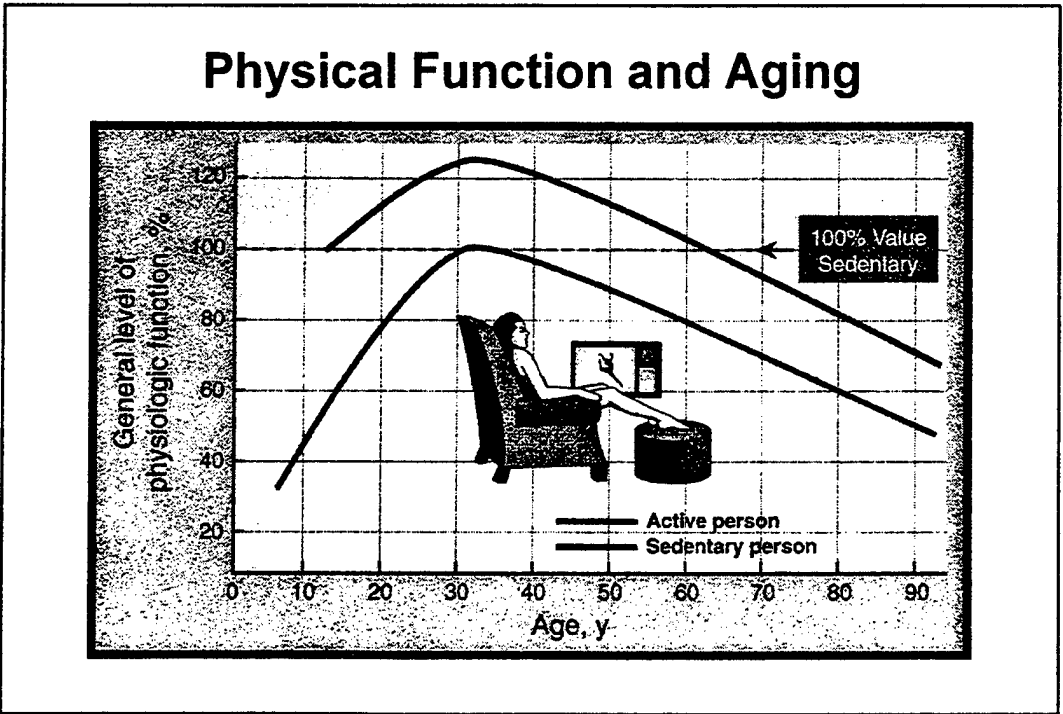
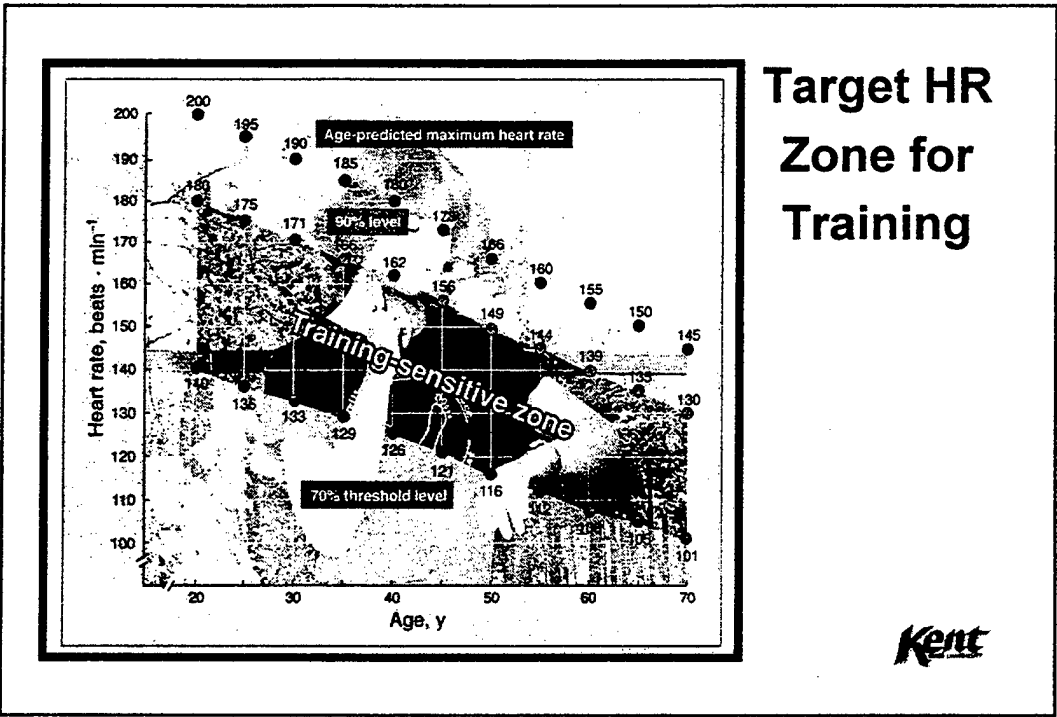

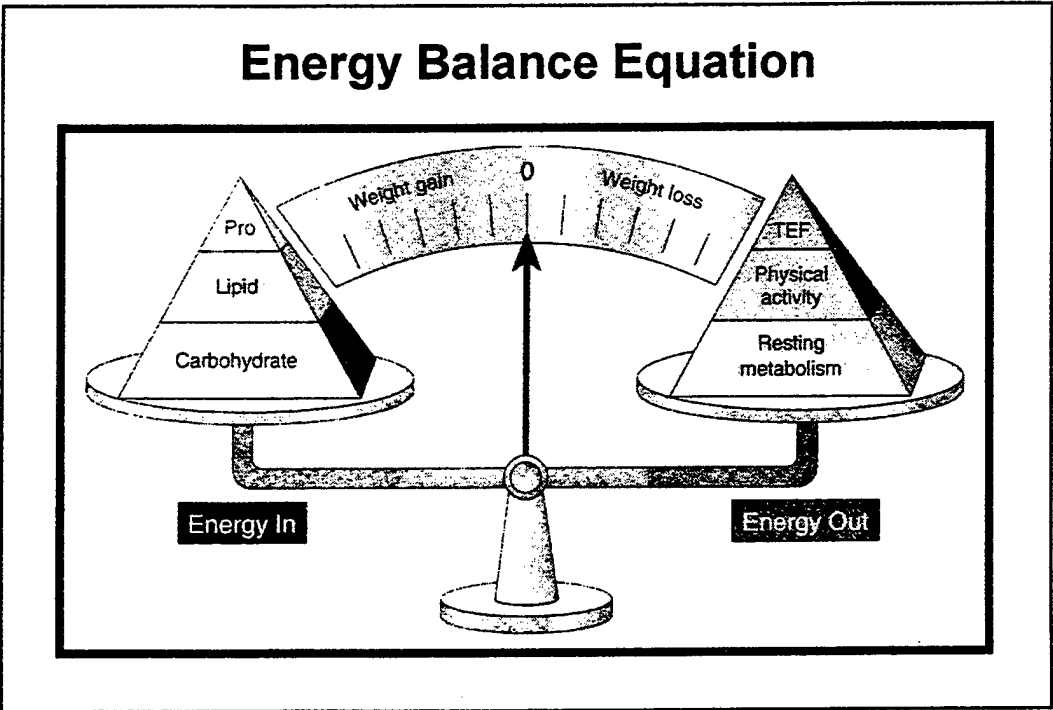
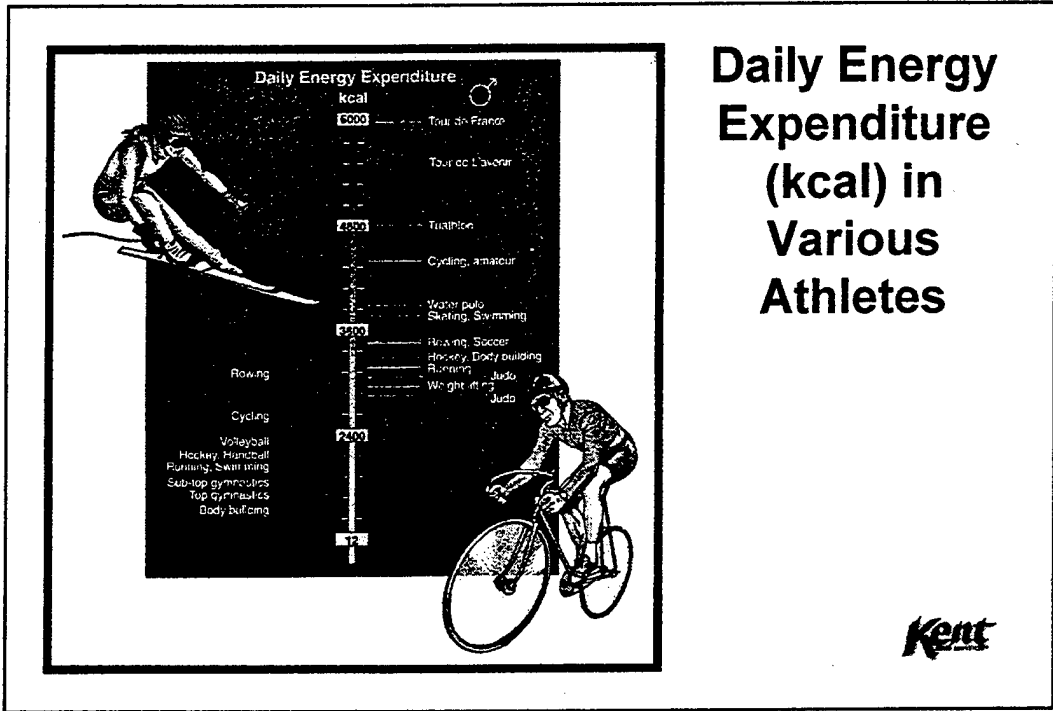

# Body Composition of Various Athletes

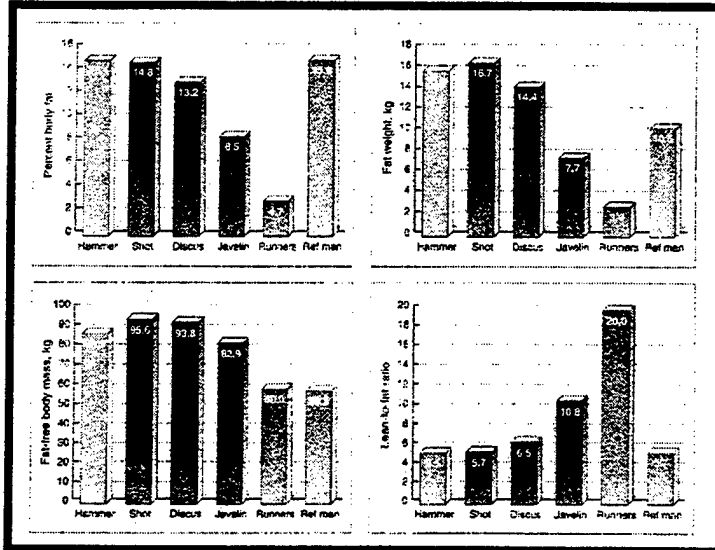

**Kent**

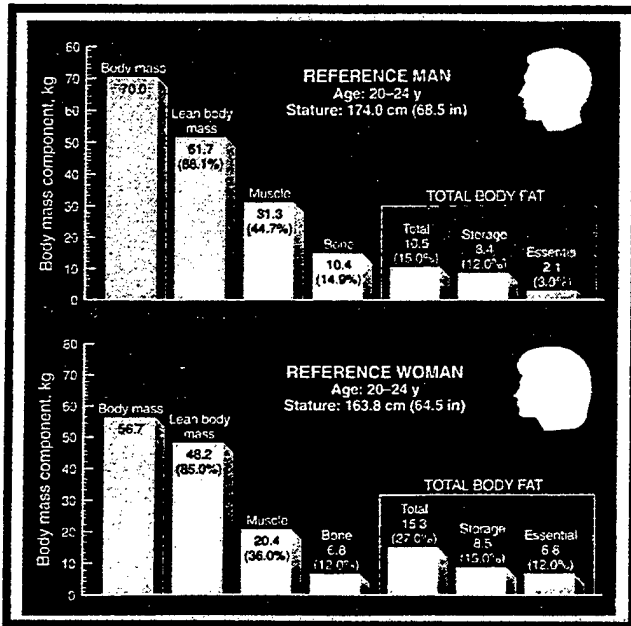

## Reference Man and Woman



**Kent**

## Average % Body Fat

Study	Age Range	Stature, cm	Mass, kg	% Fat
<b>Younger women</b>				
North Carolina, 1962	17-25	165.0	55.5	22.9
New York, 1962	16-30	167.5	59.0	28.7
California, 1968	19-23	165.9	58.4	21.9
California, 1970	17-29	164.9	58.6	25.5
Air Force, 1972	17-22	164.1	55.8	28.7
New York, 1973	17-26	160.4	59.0	26.2
North Carolina, 1975		166.1	57.5	24.6
Army Recruits, 1986	17-25	162.0	58.6	28.4
Massachusetts, 1996	17-30	165.2	57.8	21.8
<b>Younger men</b>				
Minnesota, 1951	17-26	177.5	69.1	11.8
Colorado, 1956	17-25	172.4	68.3	13.5
Indiana, 1966	18-23	180.1	75.5	12.6
California, 1968	16-31	175.7	74.1	15.2
New York, 1973	17-26	176.4	71.4	15.0
Texas, 1977	18-24	179.9	74.6	13.4
Army Recruits, 1986	17-25	174.7	70.5	15.6
Massachusetts, 1996	17-30	178.1	76.4	12.9

## Body Composition of Olympic Athletes

Specialty	Event	Olympics	N	Age (yr)	Stature (cm)	Mass (kg)	LBM* (kg)	Body Fat (%)
Sprint	100-200 m	Tokyo	172	24.9	178.4	72.2	64.0	10.1
	4 x 100 m							
Long distance	110-m hurdles	Mexico City	79	25.9	175.4	68.4	62.5	5.2
	3000, 5000	Tokyo	99	27.3	173.6	62.4	61.5	1.4
Marathon	10,000 m	Mexico City	34	25.3	171.9	59.5	60.1	-0.5
	42.2 km	Tokyo	74	25.3	170.3	60.8	59.2	2.7
Decathlon		Mexico City	20	26.4	168.7	56.6	55.1	2.7
		Tokyo	26	26.3	183.2	83.5	65.5	15.0
Jump	High jump	Mexico City	8	25.1	181.3	77.5	67.1	13.4
	triple jump	Tokyo	59	25.3	181.5	73.2	65.2	5.2
Weight throwing	Shot	Mexico City	14	23.5	182.8	73.2	68.2	6.8
	discus	Tokyo	79	27.6	187.3	101.4	71.6	29.4
Swimming	hammer	Mexico City	9	27.3	185.1	102.3	70.7	30.9
	Free breast back	Tokyo	450	20.4	178.7	74.1	65.1	12.1
	butterfly medley	Mexico City	66	19.2	179.3	72.1	65.6	9.0



**Kent**

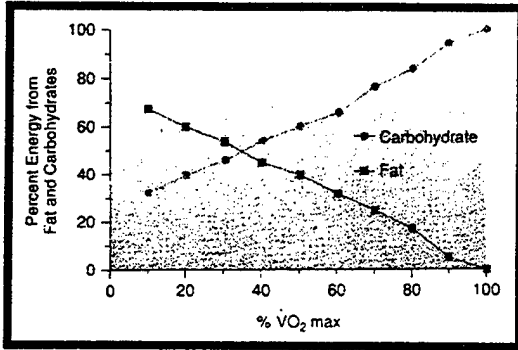

## Crossover Principle Relative to Intensity

## Crossover Principle During Prolonged Exercise

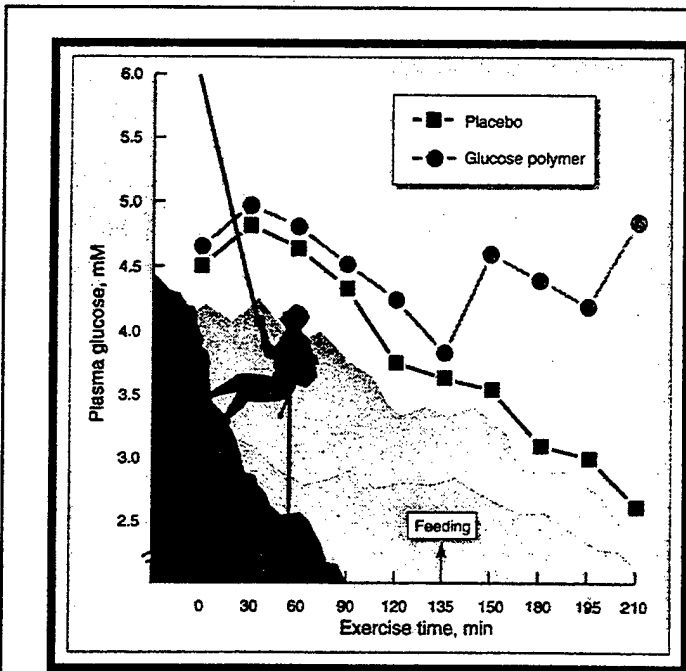
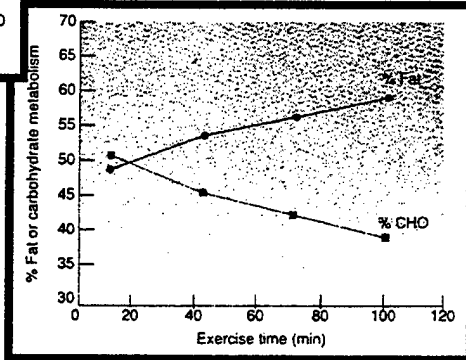

## Glucose Concentration during Exercise

## Placebo vs Glucose

**Kent**

## Glycogen Depletion

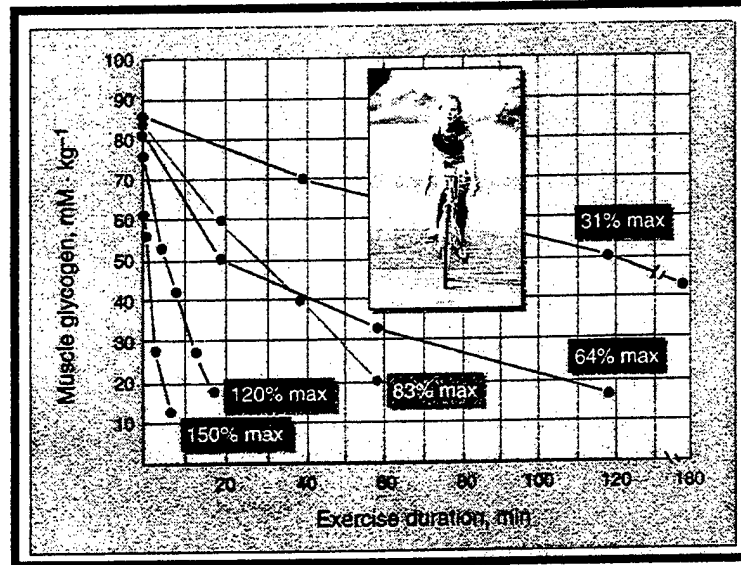

Kent

## Methods of Heat Loss and Gain

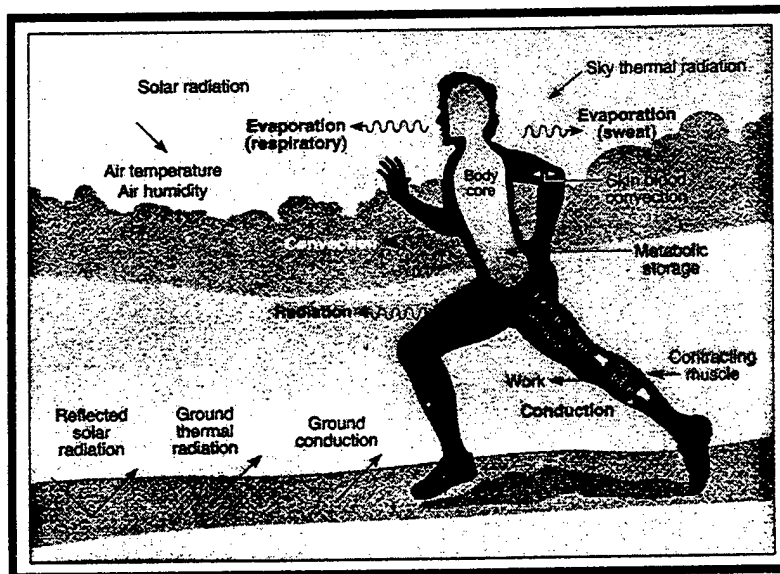

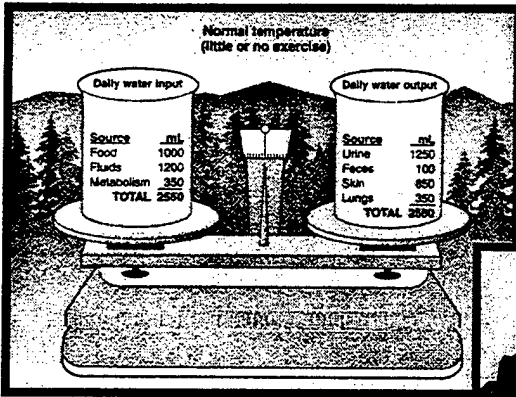

## Water Balance Normal Temp (little or no exercise)

## Water Balance Hot Weather (heavy exercise)

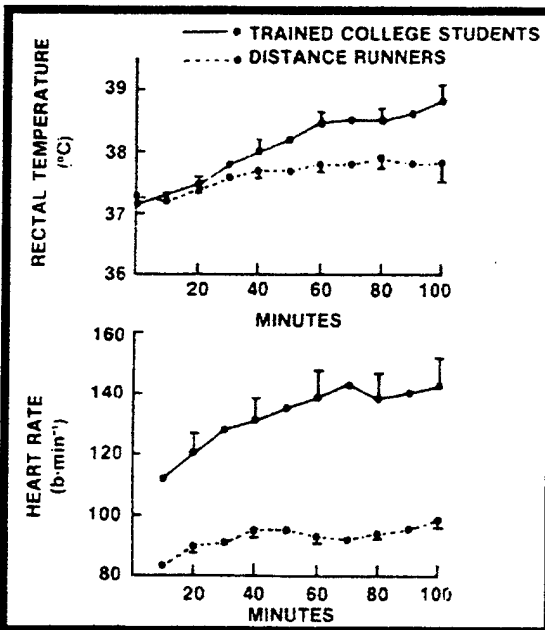
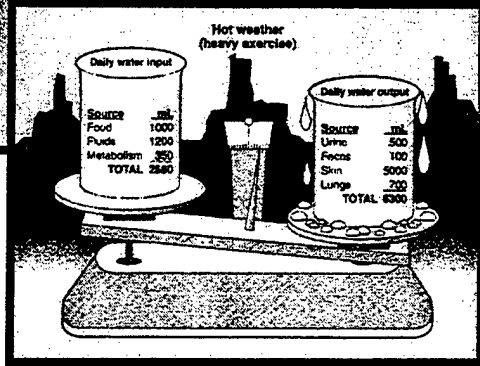

## HR and Tre during Exercise in Dry Heat

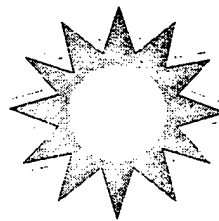

**Kent**

# HR and Tre Effects of Acclimation

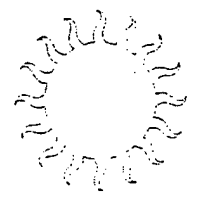
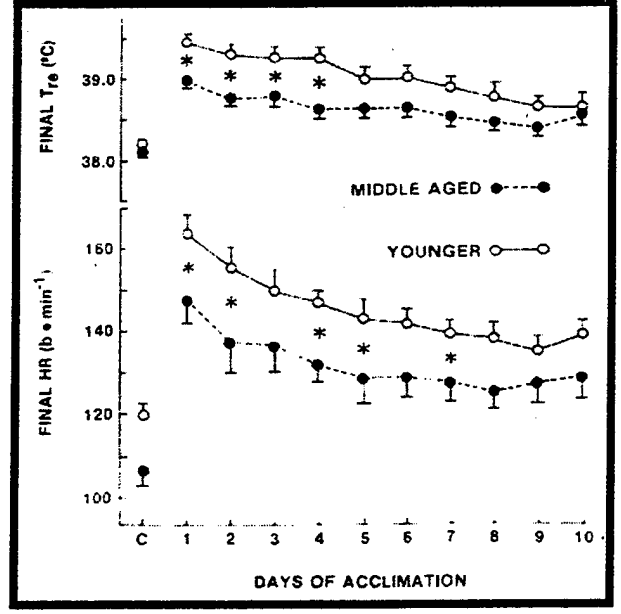

**Kent**

# The Aerobic System

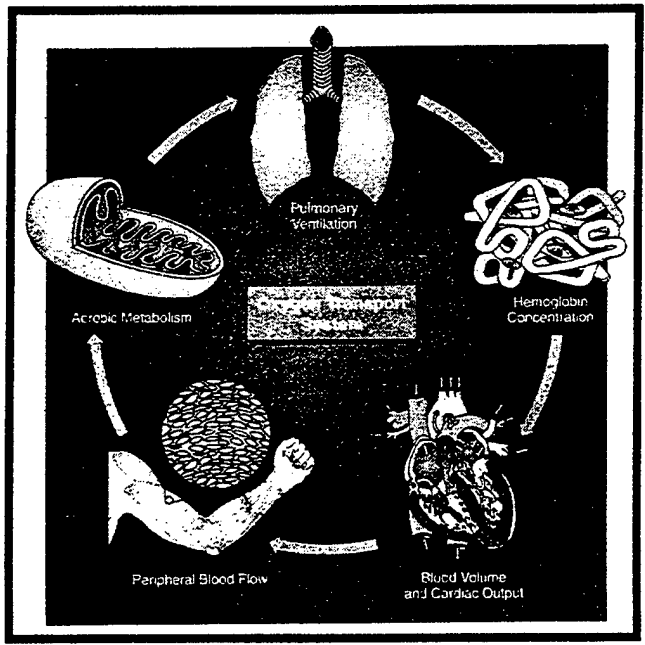

**Kent**

## Goals of Aerobic Training

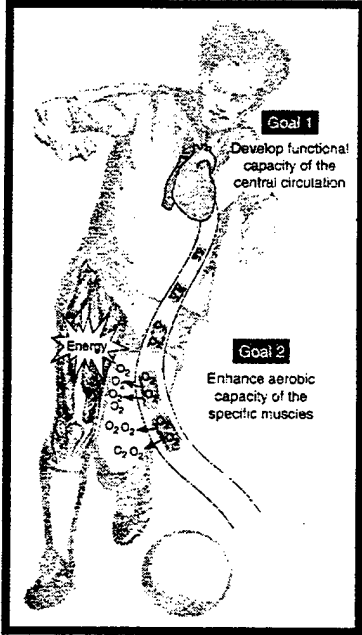

- Delivery of Oxygen
- Utilization of Oxygen

*Kent*

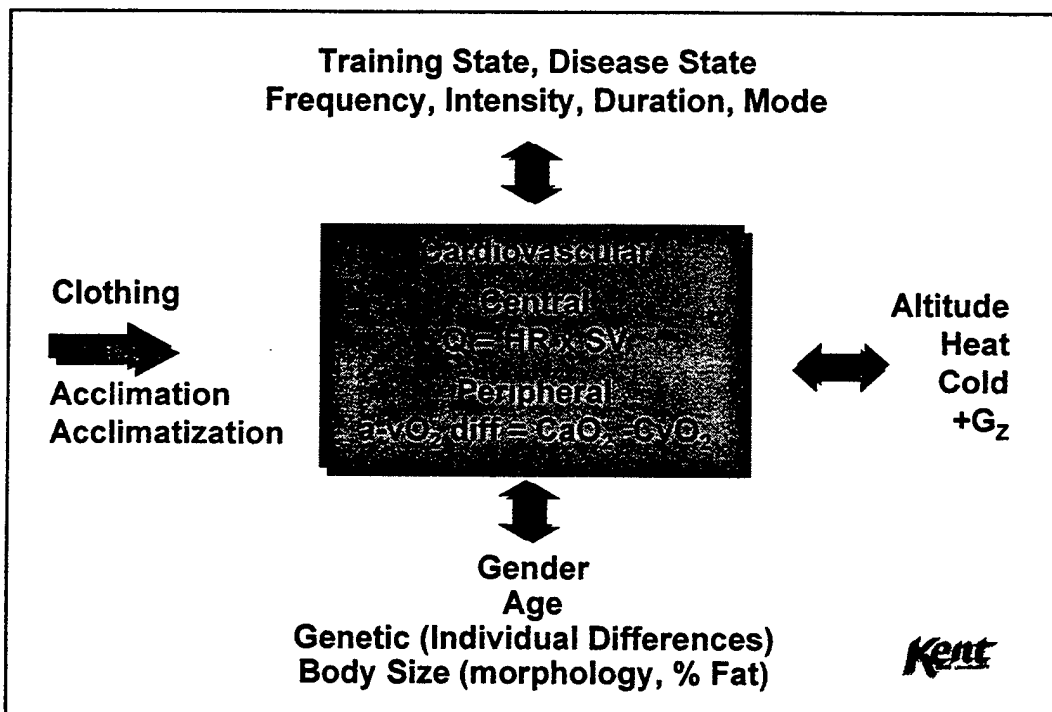

# **FACTORS THAT INFLUENCE PHYSIOLOGICAL AND THERMAL RESPONSES TO RESTING COLD EXPOSURE**

**E. Glickman-Weiss, Ph.D., FACSM**

**Kent State University  
Exercise Science Laboratory  
School of Exercise, Leisure & Sport**

## **Cold Exposure Research**

- **Survivability: Navy dictum "You are not dead until you are warm and dead"**
- **Performance: Substrate utilization, delay onset of fatigue**
- **Insulation: Clothing vs. Body Fat**



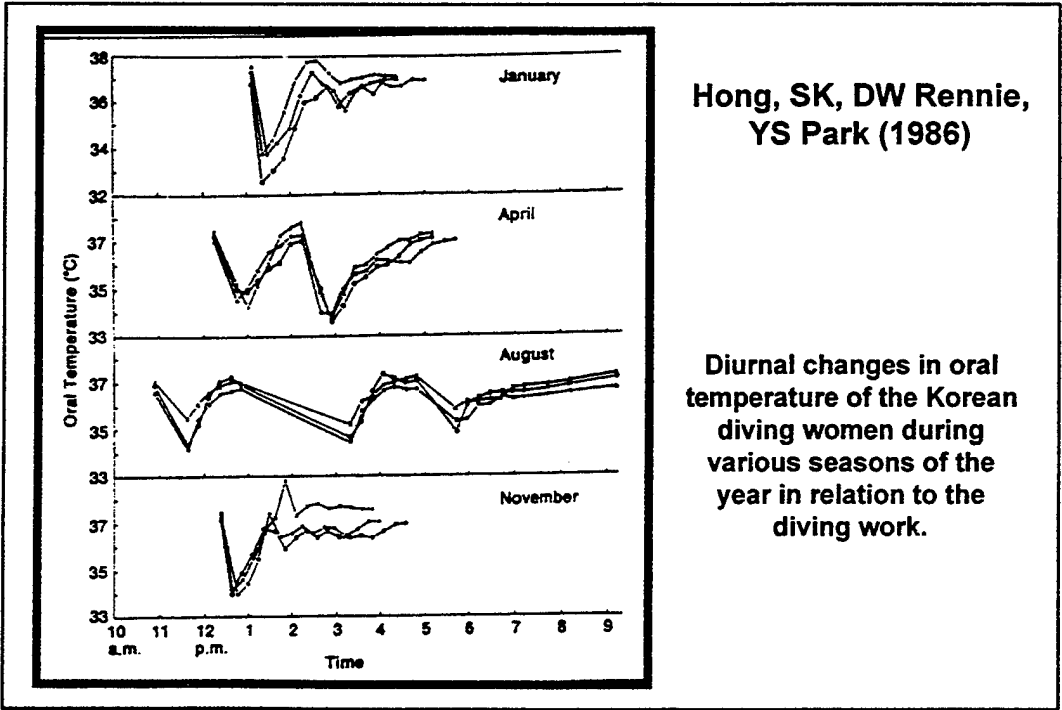
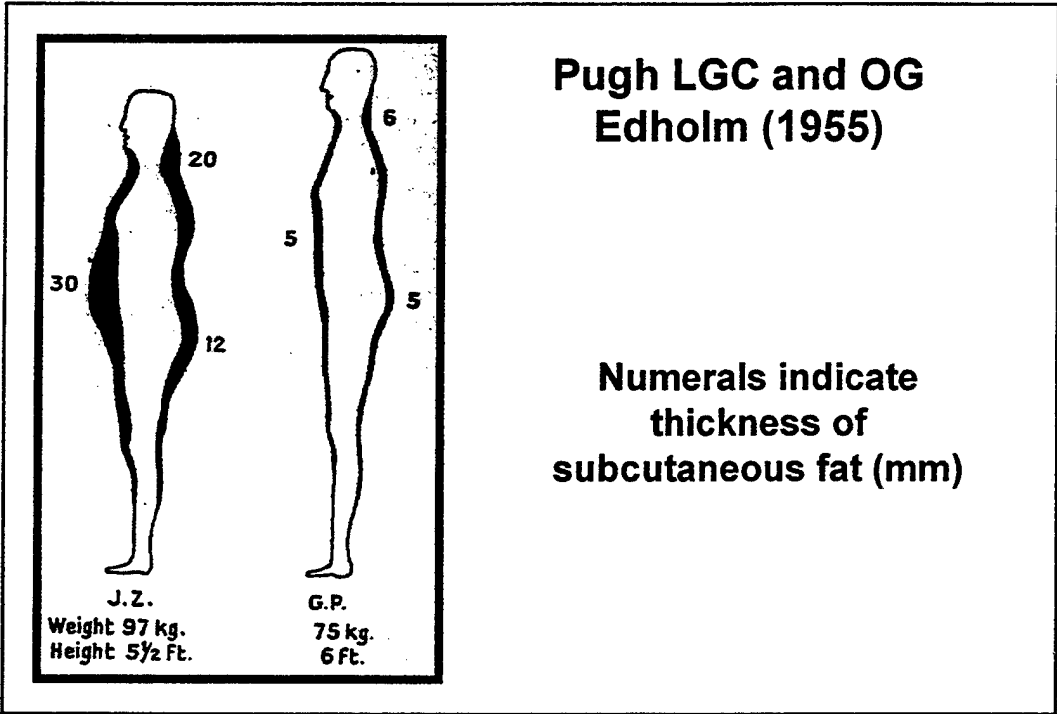

**PHYSIOLOGICAL AND THERMAL  
RESPONSES OF MALES WITH VARYING  
BODY COMPOSITION DURING IMMERSION  
IN MODERATELY COLD WATER**

**E Glickman-Weiss, FL Goss, RJ Robertson,  
KF Metz, DA Cassinelli**

**Aviat Sp Environ Med (1991) 92:1063-7**

**Subject Characteristics**

Variable	Low Fat (n = 12)	High Fat (n = 12)
	$\bar{X} (\pm S.D.)$	$\bar{X} (\pm S.D.)$
Percent Fat	10.29 (1.44)	19.79 (2.14)
Sum of Skinfolts (mm)*	77.24 (20.85)	131.06 (40.23)
Weight (kg)	80.69 (12.04)	84.90 (15.02)
Height (cm)	181.03 (6.85)	177.48 (7.43)
Age (year)	24.75 (4.07)	30.00 (5.22)
Surface Area: Mass Ratio ( $\text{cm}^2 \cdot \text{kg}^{-1} \cdot 100$ )	2.01 (0.17)	2.02 (0.20)

\* Sum of skinfolts include: chin, subscapula, chest, suprailium, tri-  
ceps, thigh, biceps, forearm, knee, side and calf.

TABLE II. BODY COMPOSITION AND DISTRIBUTION ACROSS EXPERIMENTAL CONDITIONS OF SUBJECTS COMPLETING 90 MIN OF COLD WATER IMMERSION.

	Water Temperature		
	18°C	22°C	26°C
Low Fat (n = 12)	$\bar{X} = 11.51$ S.D. = 1.08 n = 4	$\bar{X} = 9.53$ S.D. = 1.25 n = 4	$\bar{X} = 9.83$ S.D. = 1.44 n = 4
High Fat (n = 12)	$\bar{X} = 18.18$ S.D. = 0.69 n = 4	$\bar{X} = 19.72$ S.D. = 2.55 n = 4	$\bar{X} = 21.48$ S.D. = 1.60 n = 4

TABLE III. MEANS AND STANDARD DEVIATIONS FOR RECTAL TEMPERATURE (°C).

Temperature (°C) Immersion time (min)	Low Fat		High Fat	
	Mean	±S.D.	Mean	±S.D.
18°C				
0*	37.2	0.2	37.4	0.2
5	37.1	0.3	37.3	0.2
15	37.0	0.3	37.2	0.2
30	36.8	0.5	37.0	0.2
45	36.6	0.6	36.8	0.4
60	36.4	0.7	36.5	0.5
75	36.1	0.7	36.4	0.4
90	35.9	0.8	36.2	0.4

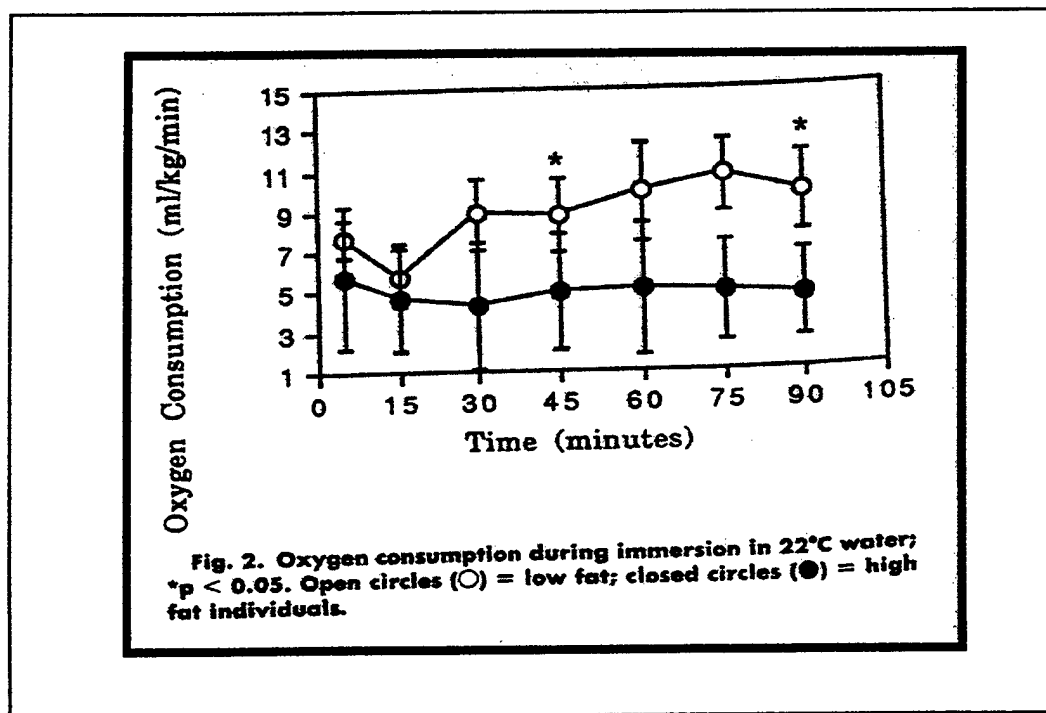
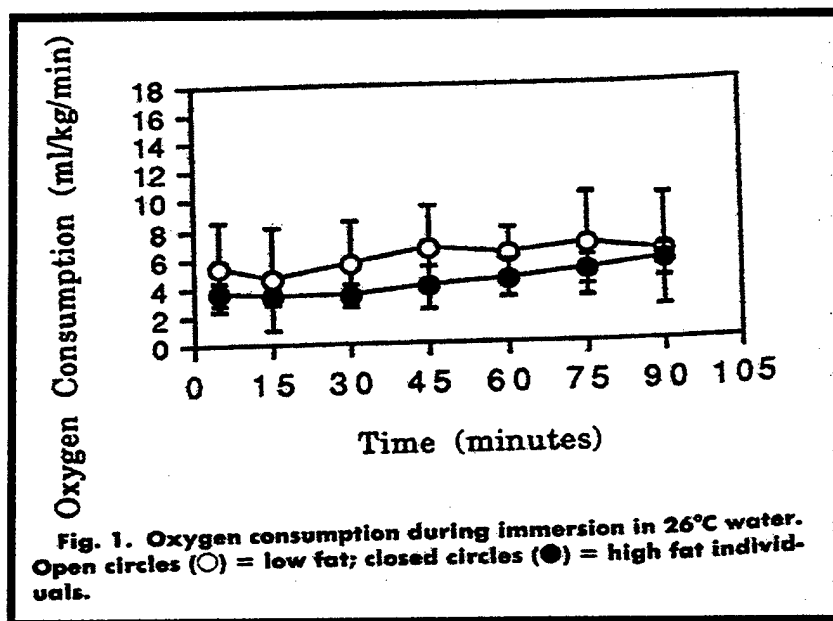

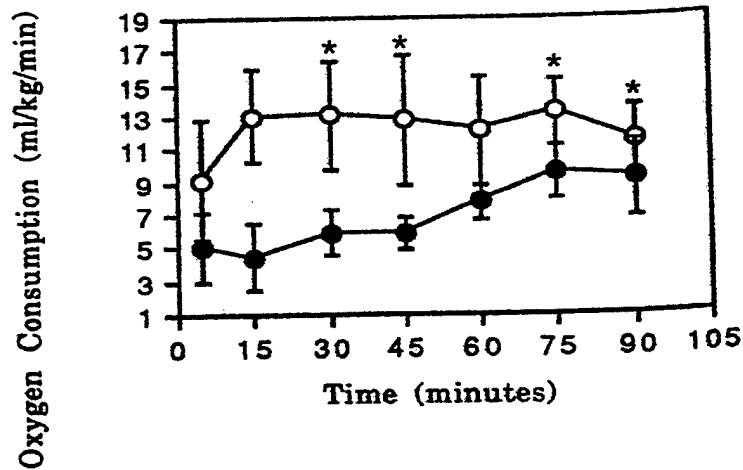

Fig. 3. Oxygen consumption during immersion in 18°C water; \*  $p < 0.05$ . Open circles (○) = low fat; closed circles (●) = high fat individuals.

### Conclusion

- The fixed resistor to heat exchange (i.e., body fat) plays an important role in the thermoregulatory and aerobic metabolic responses to protracted resting cold water immersion.
- Although at a marked disadvantage, given the smaller resistive component to heat exchange, the LF (low fat) group was able to maintain  $T_{re}$  when compared to the HF (high fat) group, due, in part, to a significantly greater aerobic heat production through shivering thermogenesis.

## Human Powered Systems *The Daedalus Project*

*Mythical Greek inventor: constructed wings of wax/feathers,  
flew from imprisonment on Crete 3500 years ago*

Route 119 km

3x human-powered  
flight of 35 km  
(1979 English Channel)

Nadel, ER and Bussolari, SR.  
American Scientist, 1988.

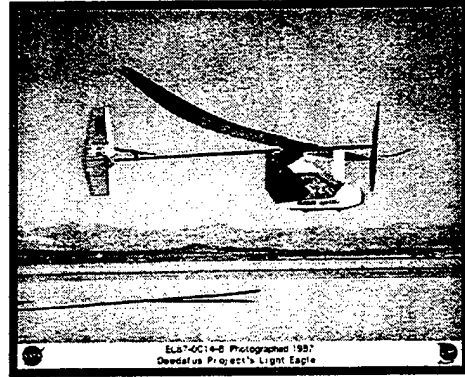

## *The Daedalus Project*

### Question

*VO<sub>2</sub>max requirement to perform 4-6 hours  
of flight?*

*Metabolic cost to the pilot of maintaining  
the constant mechanical power?*

### Answer

69.9 mlO<sub>2</sub>•kg<sup>-1</sup>•min<sup>-1</sup>

**Kent**

## ***The Daedalus Project (Endurance Test)***

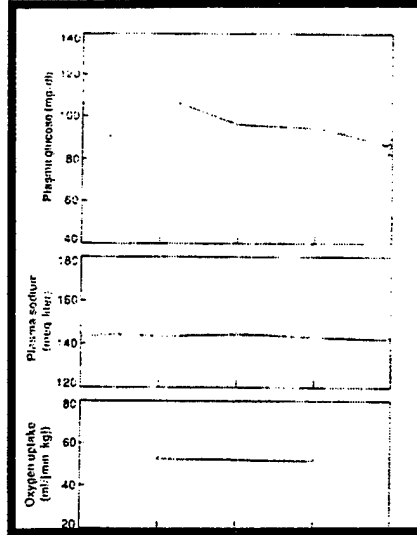
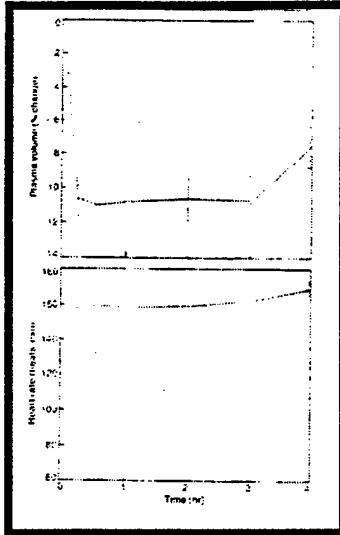

## ***The Daedalus Project (Endurance Test)***

**The results of a 4 hour endurance test indicated that the Daedalus flight was physiologically possible**

**11 Athletes at 70%  $VO_2$ max**

**Kent**

## The Daedalus Project (Daedalus Drink)

(1L / hr)

- **Maintain Tre**
- **Sufficient**
  - carbohydrates
  - electrolytes
  - glucose
  - sodium
- **Total Body Water**



**Kent**

## The Daedalus Project (Effectiveness of Daedalus Drink)

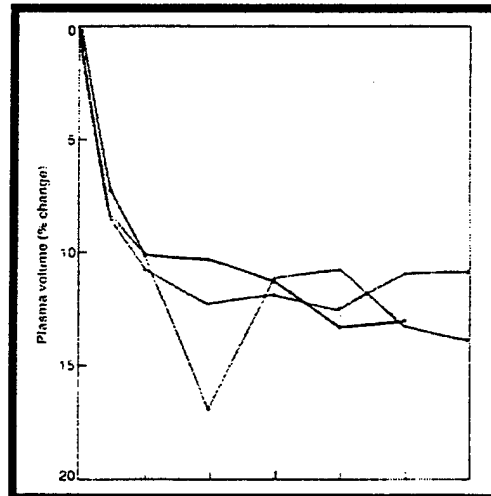
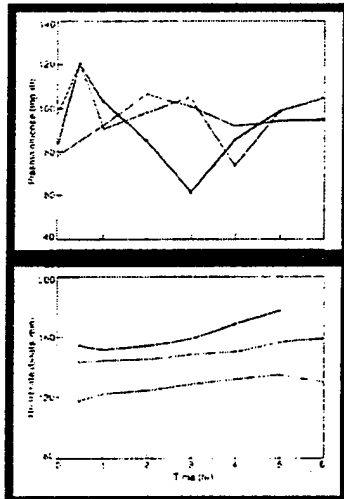

## ***The Daedalus Project Postscript***

- 23 April 1988, the Daedalus lifted off
- 4 hours and 119 km later Daedalus made a water landing into a 12 knot headwind
- Pilot Kanellos Kanellopoulos
  - Consumed 4 L energy electrolyte
  - HR  $\leq$  142 bpm
  - No indication of impending fatigue

**Kent**

## **PHYSIOLOGICAL FACTORS THAT MAY LIMIT AND TECHNIQUES THAT MAY ENHANCE HUMAN PERFORMANCE**

**E. Glickman-Weiss, PhD, FACSM**



**Exercise Sciences  
Laboratory**

**Kent State University**

November 2, 1997

**TECHNOLOGY SESSION 1**

**“ELECTROSTATIC INTEGRATED FORCE ARRAYS”**

**Dr. Scott H. Goodwin-Johansson**

**MCNC  
Research Triangle Park, NC 27709**

INTEGRATED FORCE ARRAYS

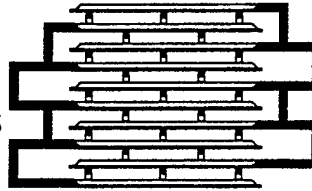

# Integrated Force Arrays

Scott Goodwin-Johansson



ELECTRONIC TECHNOLOGIES DIVISION

INTEGRATED FORCE ARRAYS

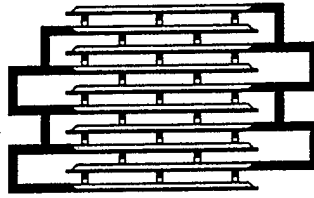

# IFA Operation

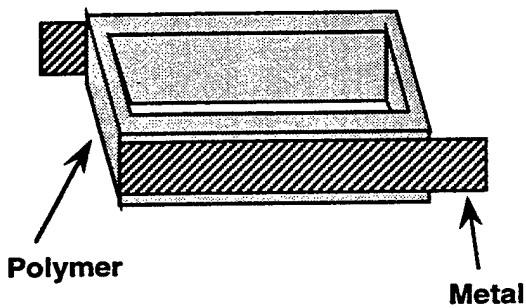

Force Cell

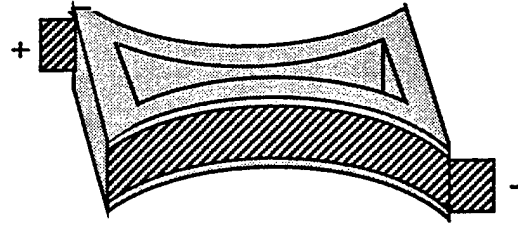

Voltage Applied

**Electrostatic Attractive Force**



ELECTRONIC TECHNOLOGIES DIVISION

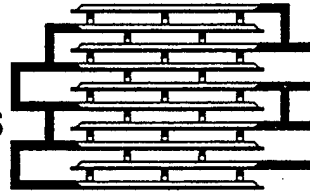

# IFA Operation

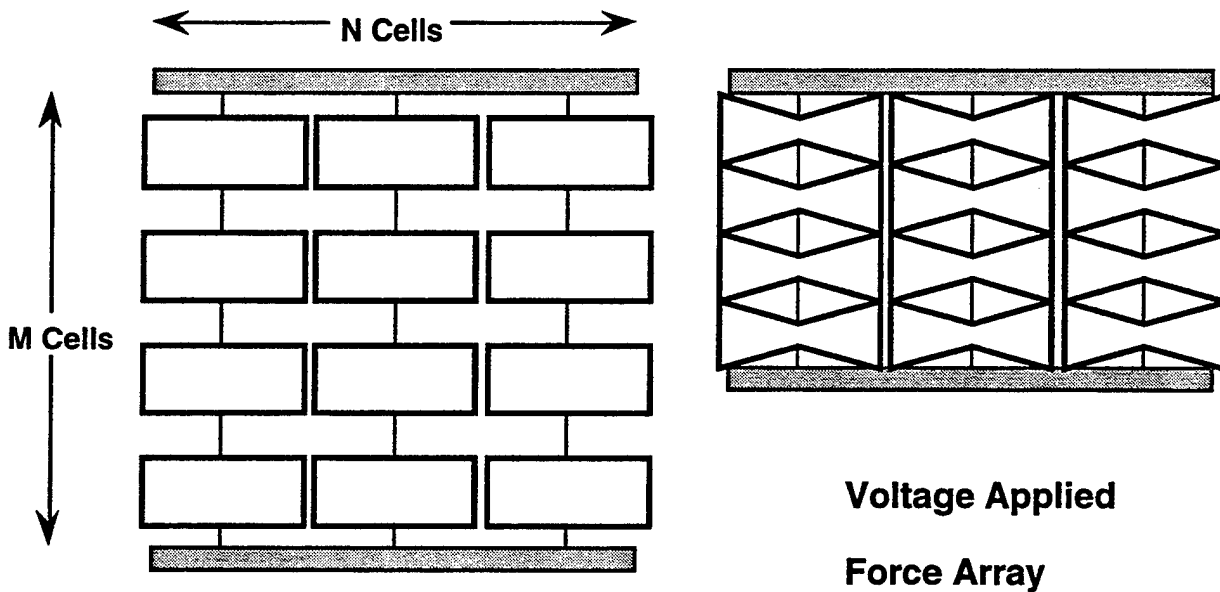

**Total Force = N X Cell Force**

**Total Displacement = M X Cell Displacement**

**Force of Individual Cell is Independent  
of Size**



ELECTRONIC TECHNOLOGIES DIVISION

INTEGRATED FORCE ARRAYS

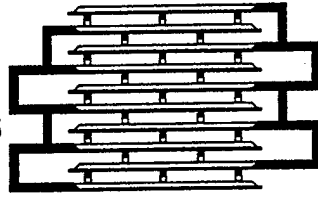

# IFA Structure

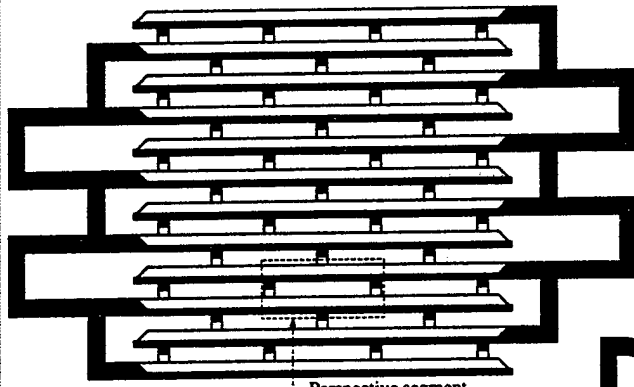

Perspective segment

Relaxed

Compressed

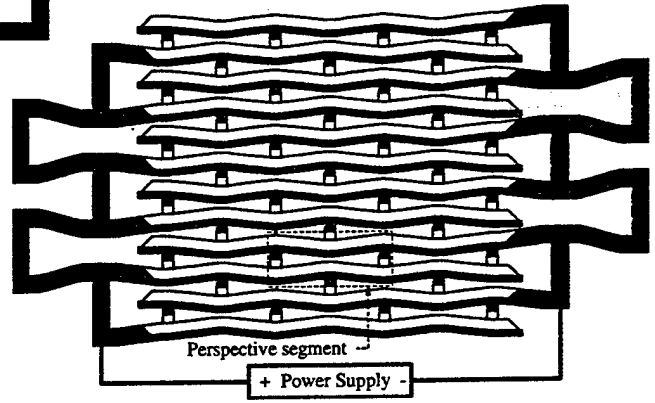

Perspective segment

+ Power Supply -

Unit cell

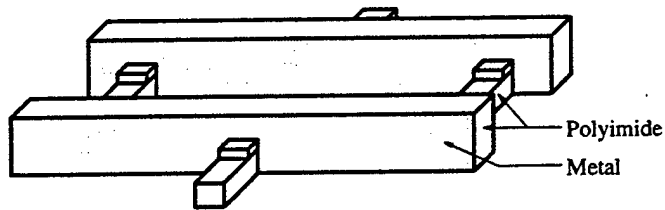

Polyimide

Metal

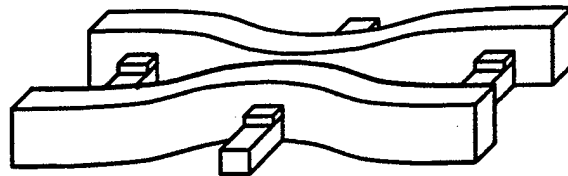

ELECTRONIC TECHNOLOGIES DIVISION

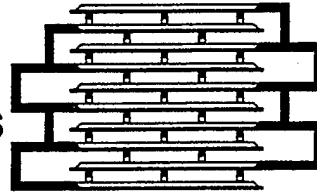

# IFA Fabrication

## Embedded Hard Mask

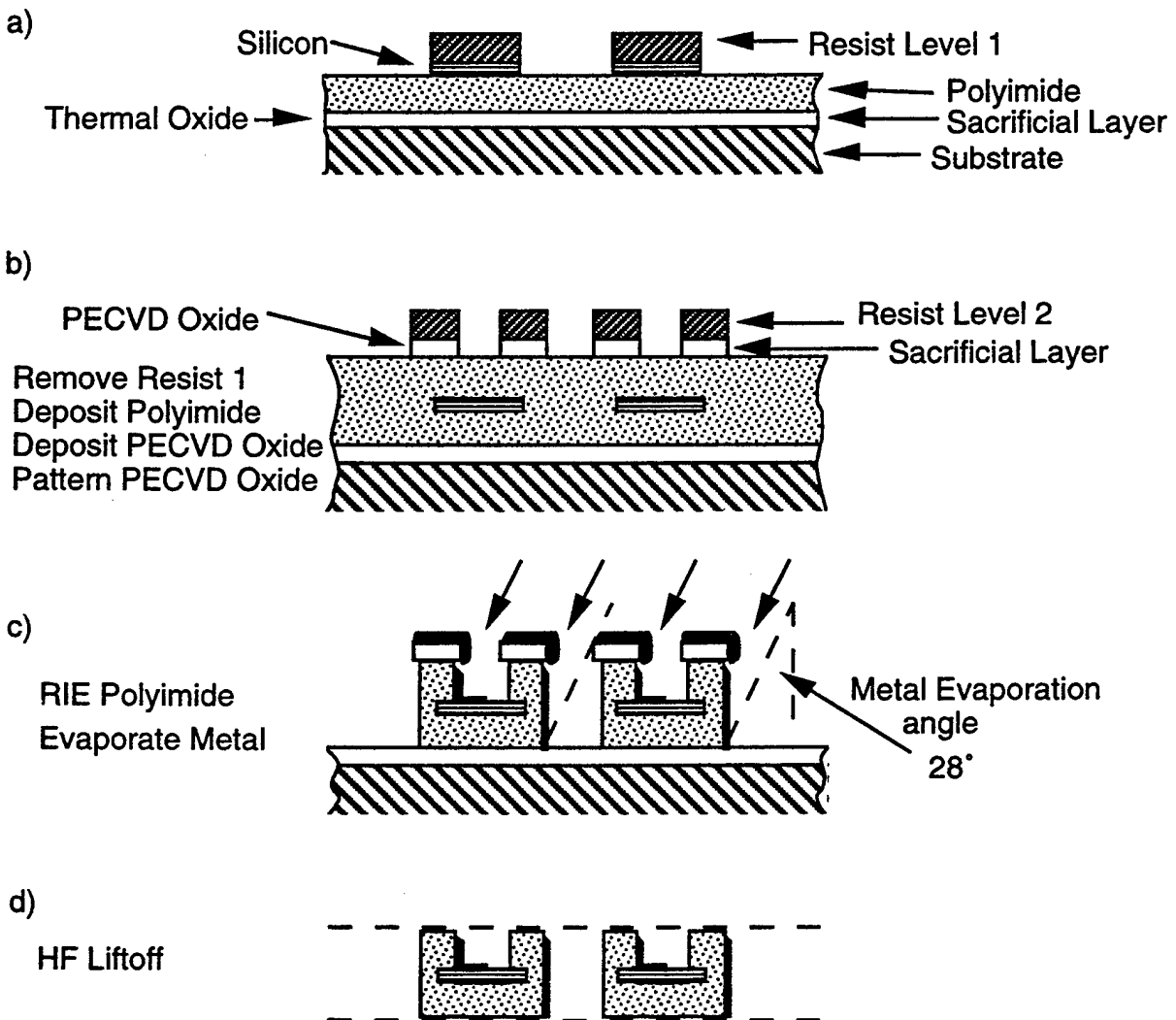

INTEGRATED FORCE ARRAYS

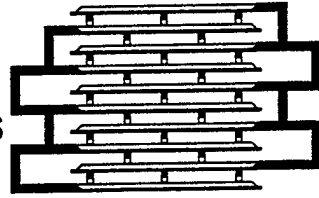

# IFA Structure

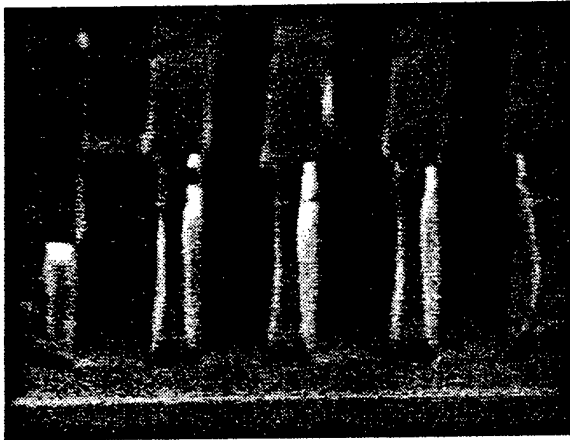

**Dual Surface  
Hard Mask**

**Embedded  
Hard Mask**

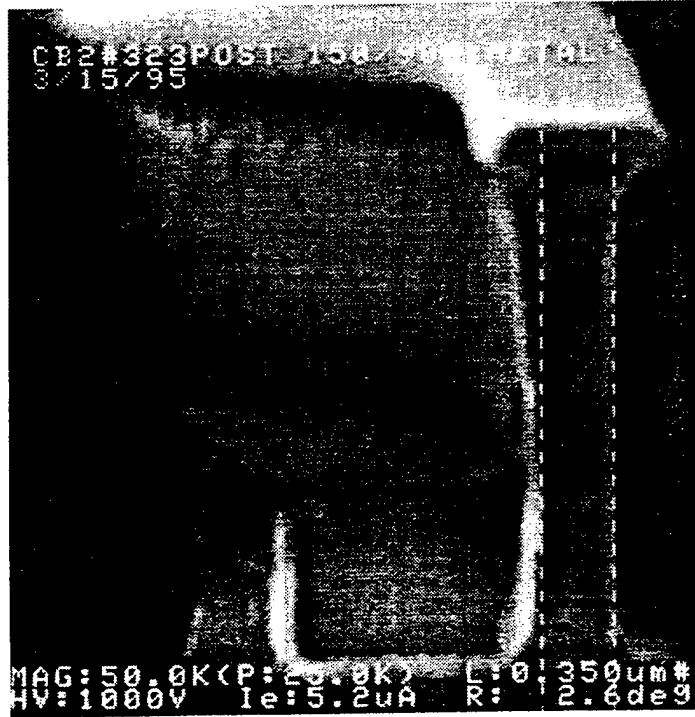

ELECTRONIC TECHNOLOGIES DIVISION

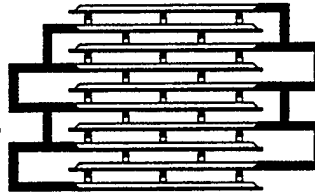

## IFA Characteristics

- **Artificial muscle**
- **Light-weight, flexible, electrostatic actuator**
- **Low Power**
- **Large displacements**
  - 20% contraction of actuator length
- **Large forces**
  - Measured work/volume  $> 15 \text{ ergs/mm}^3$
- **High speed**
  - $>20,000$  contractions per second
- **Reliable**
  - Measured lifetimes  $>10^8$  contractions



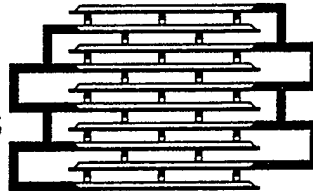

# Measured Force

Theoretical curves and measured data points as a function of the applied voltage

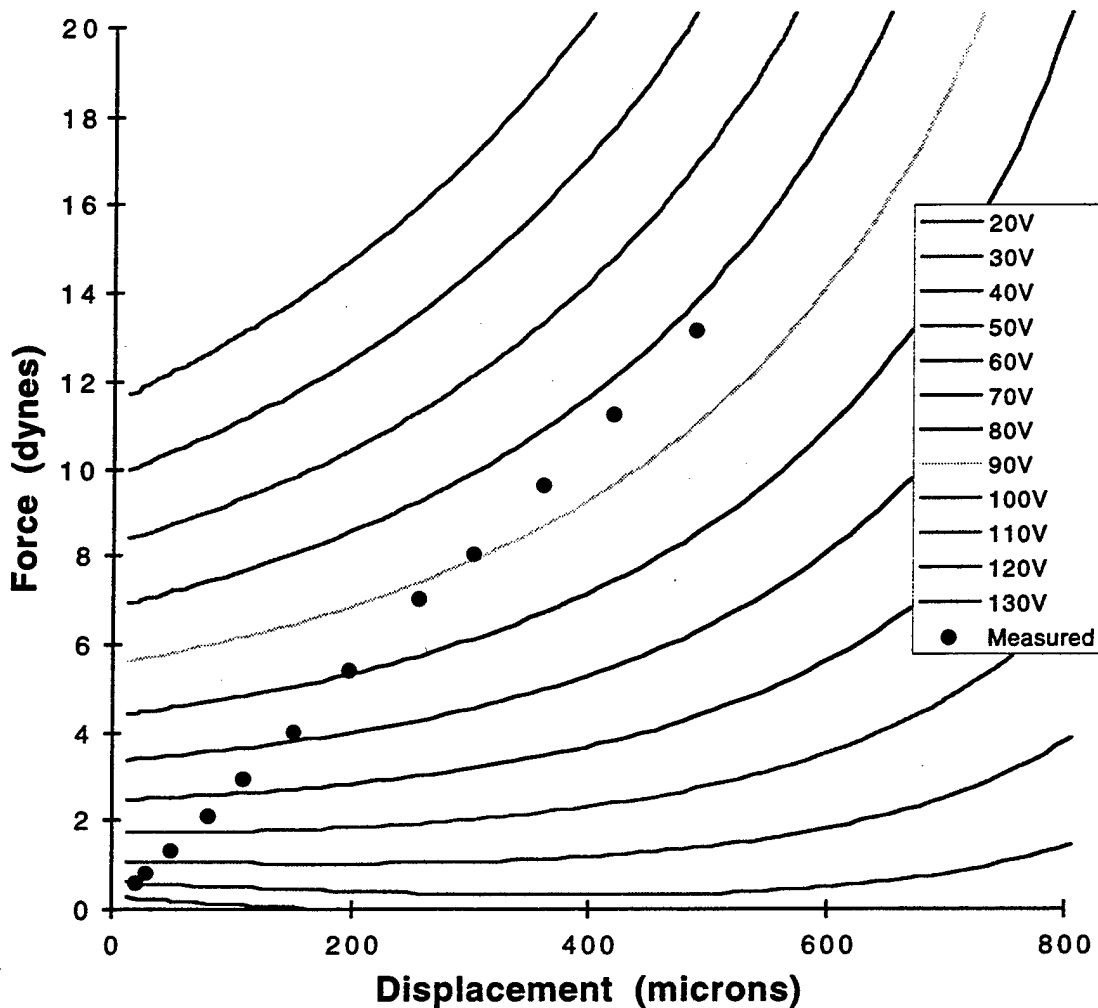

Measured data in 10V increments beginning at 20V



ELECTRONIC TECHNOLOGIES DIVISION

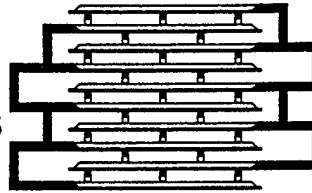

# IFA Applications

- **Small, fast actuators**
  - Positioning of magnetic disk drive read heads
  - Optical shutters
- **Mechanical actuation**
  - Replace electromagnetic solenoids with 5% the volume and 0.6% the mass
  - Robotics
- **Biomechanics and biomedical devices**
  - Prosthetic devices
  - Catheter steering
- **Sensors**
- **Power generation**



INTEGRATED FORCE ARRAYS

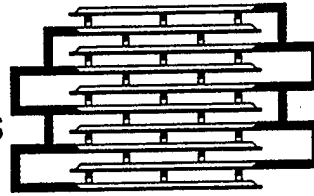

## IFA Power Generation

- **Convert mechanical work into electrical energy**
- **Operate in an energy cycle**
- **218cm<sup>3</sup> IFA generates 1W**
  - 1Hz cycle
  - Maximum voltage 100V
  - 1.7 $\mu$ m plate pitch
  - 50% efficiency



ELECTRONIC TECHNOLOGIES DIVISION

INTEGRATED FORCE ARRAYS

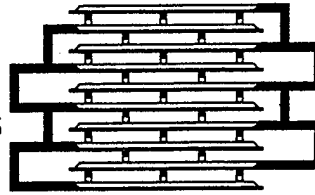

# IFA Power Cycle

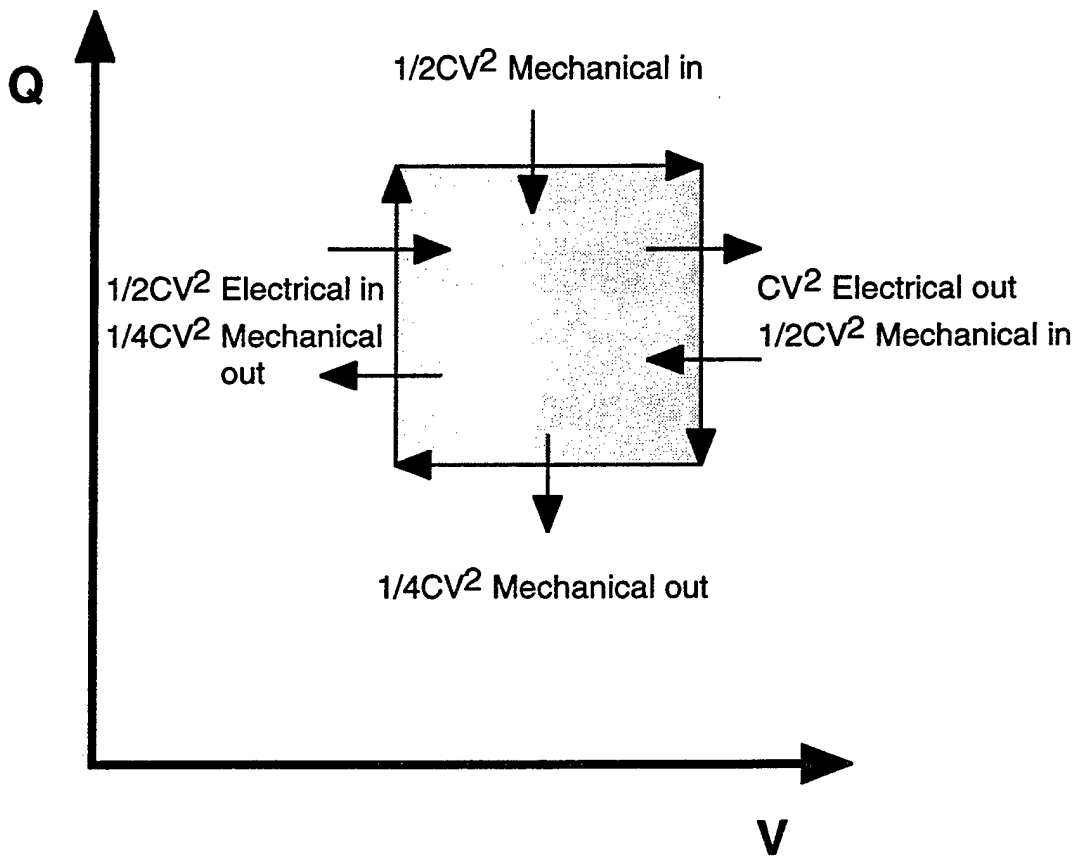

ELECTRONIC TECHNOLOGIES DIVISION

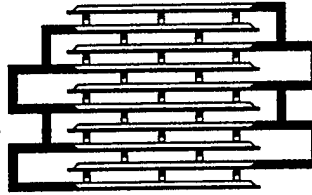

# Outstanding Issues

- **Verify operation**
- **Optimize structure**
- **Fabrication of larger structures**
- **Low cost fabrication methods**



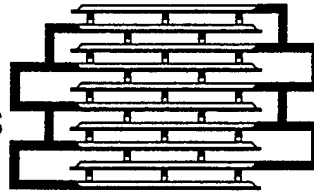

## Conclusions

- **The concept of the IFA has been experimentally verified**
- **IFAs are low power, low weight, flexible actuators**
- **Good measured actuator performance characteristics**
- **IFA can be operated to convert mechanical work into electrical energy**



**“ENERGY CONSERVATION AND ALTERNATIVE ENERGY  
SOURCES FOR WEARABLE ELECTRONICS”**

**Dr. Daniel P. Siewiorek**

**Carnegie Mellon University  
Pittsburgh, PA 15213-3890**

# Energy Conservation and Alternative Energy Sources for Wearable Electronics

November 3, 1997

by  
Daniel P. Siewiorek

© 1997, Daniel P. Siewiorek

DARPA

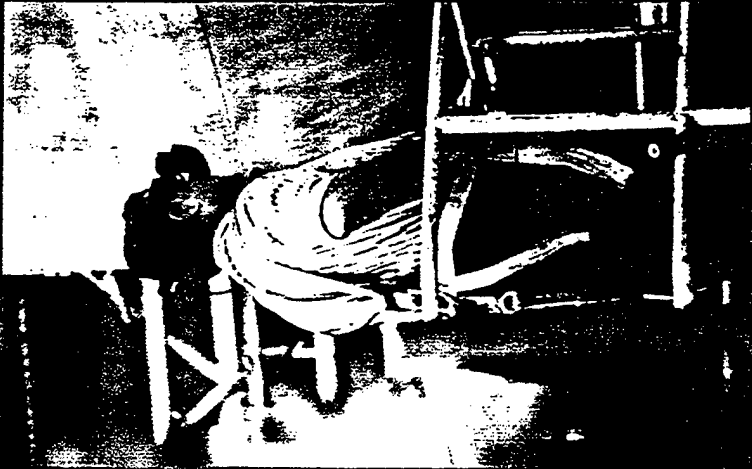



# *Conservation vs Generation*

- Reduce consumption by adapting design to application
- On demand or continuous



# Time Rate of Change of Energy Consumption

Fraction of System Power	1993	1995	2001
Computer	63%	29%	10%
Display	19%	29%	10%
Radio	18%	43%	80%
Total	33W	9W	2W





## *Conservation Techniques*

- Operating System. “Idle” loop. Unused functionality
- Disk Drive. Load and execute. Modify usage pattern to take advantage of technology differences (i.e. magnetic spinning disk vs solid state)



# Conservation Techniques (continued)

- Hardware. Remove unused components. Adjust clock frequency to demands of application. Sensors to enable circuits on demand (e.g. display, “onset of speech”)



# Impact of Power Management on Wearable Computers

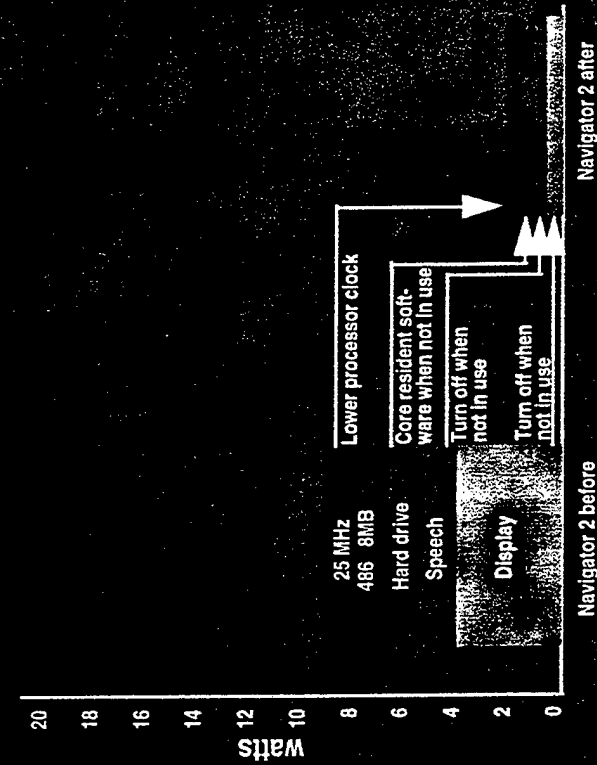

Navigator 2 power consumption

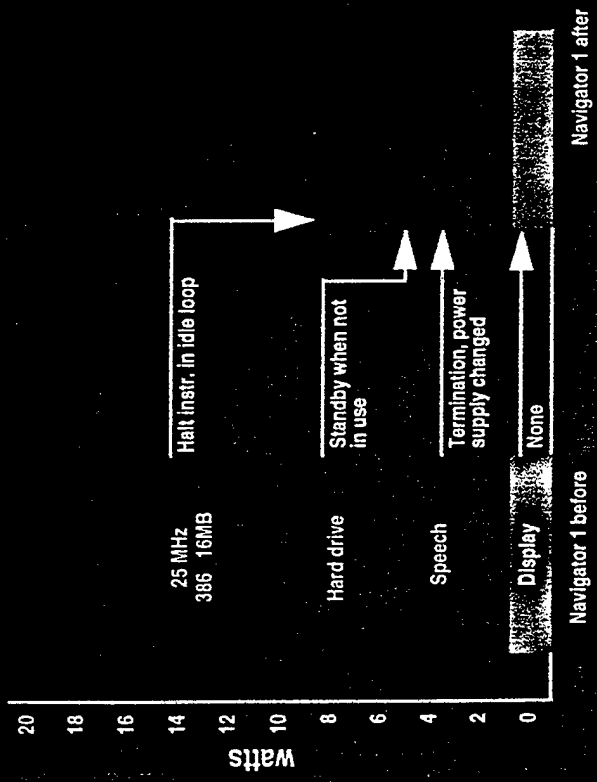

Navigator 1 power consumption

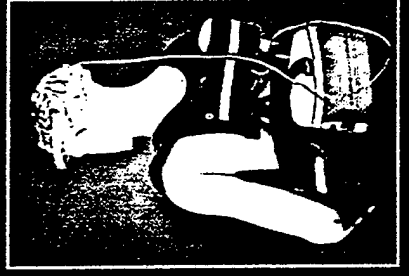

# Power Consumption in a Dedicated Wearable Computers

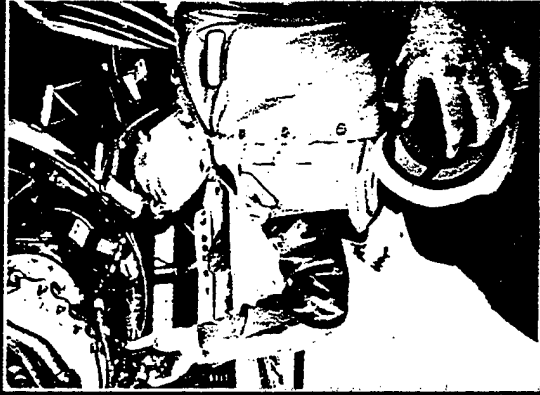
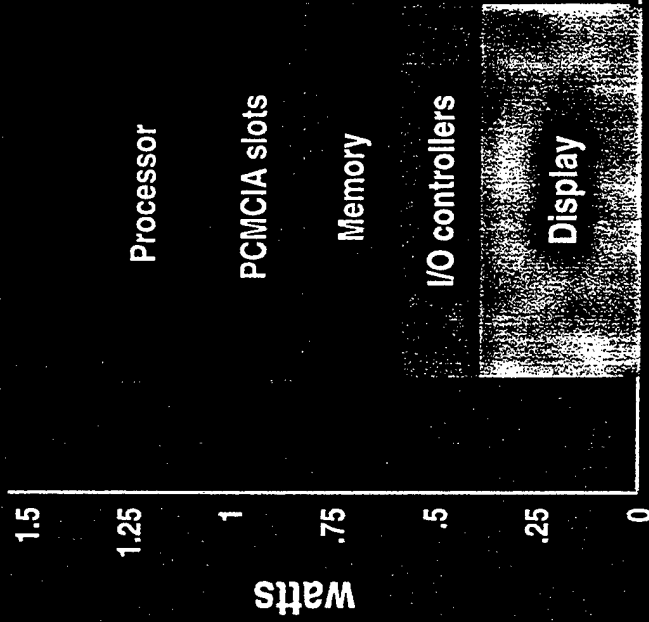

Vu Man 3 power consumption

DARPA

# Power Consumption Profile for VuMan2

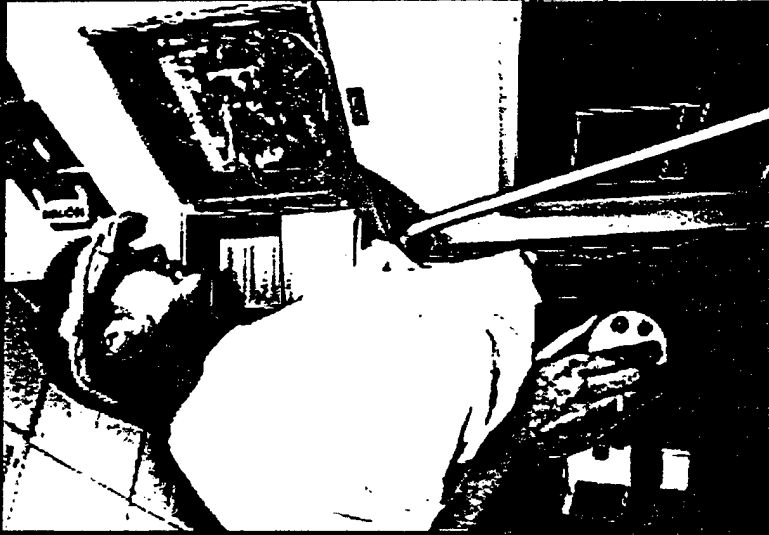
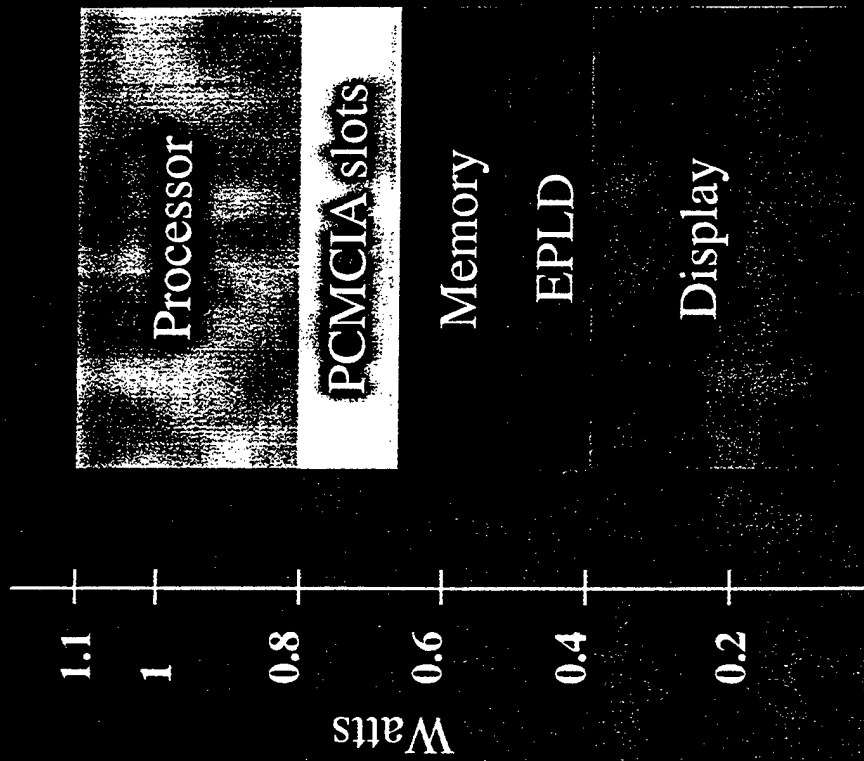

Vu Man 2 Power Consumption



# *Generation*

## *On Demand*

- Fly wheel/ generator
- Chemical
  - gas generation
  - electrochemical reaction
- Kinetic
  - electrical induction

## *Continuous*

- Piezoelectric
- electromechanical couplers



# On Demand Electro/Mechanical Energy Generator

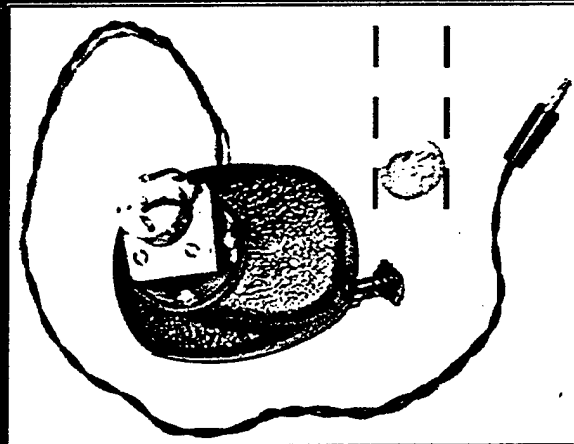
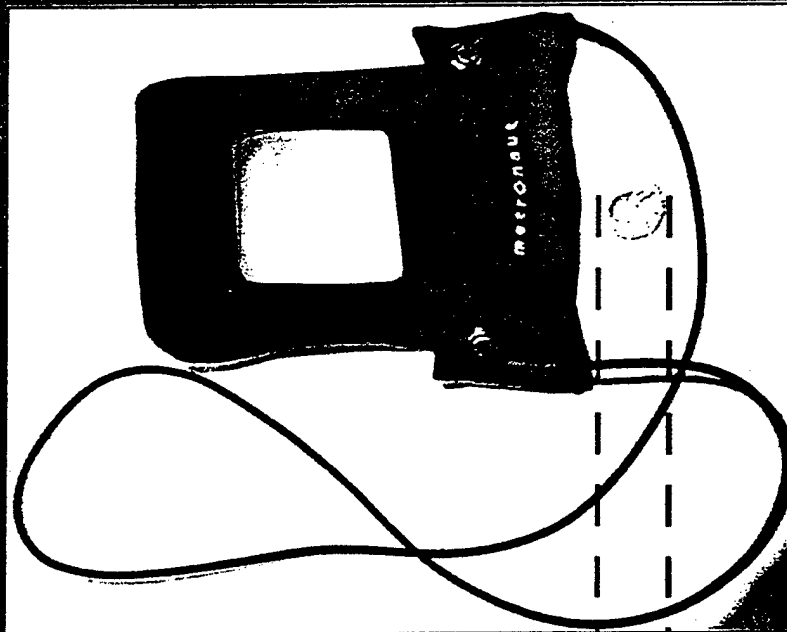

DARPA



**“ENERGY STORAGE/CONVERSION MATERIALS”**

**Dr. Ralph Zee**

**Materials Research and Education Center  
Auburn University, AL 36849**

## Power Generation based on Piezoelectricity

Ralph Zee

Materials Research and Education Center

Auburn University, AL 36840

(334)844-3320, Fax: (334)844-3400, Email: rzee@eng.auburn.edu

### Summary

There are different means to conversion mechanical energy from human motion into electrical energy. A significant amount of energy is dissipated by the walking (and running) motion of a person. Early development of this type of materials concentrated on ceramic materials such as PZT (lead zirconate titanate) and  $\text{BaTiO}_3$ . The use of piezoelectric materials has significantly increased in the advent of piezoelectric polymers, such as polyvinylidene fluoride (PVDF) in 1969. The flexibility, ductility, low cost and high conversion efficiency of these polymers compared to traditional piezoelectric ceramics have greatly enhanced the commercial applications of this class of materials. Numerous companies have been formed dedicated to the promotion, development and sales of these materials (such as AMP Inc.). Much of the effort has been devoted to the use of piezoelectric materials as sensors and transducers and even actuators. For example, devices based on PVDF have been developed as frequency counter, impact monitor, contactless keyboards, echo pulse sensors, sheet speakers, wear indicators, just to name a few.

The area of piezoelectric materials that has not been extensively explored is the generation of electrical energy from mechanical deformation of the piezoelectric process. In recent years, athletic shoe companies have incorporated piezoelectric films in the sole to convert mechanical energy into electricity to activate warning lights for night joggers. Medical researchers have attempted to use PVDF to generate power inside the body. PVDF has also been used as actuator switches using electricity generated by mechanical motion.

Content of the presentation will concentrate on the following topics:

- (1) History and basic concept of the piezoelectric effect and piezoelectric materials,
- (2) the governing equations for power generation using such a material,
- (3) Feasibility, limitation of this conversion process and issues to be addressed.

**Energy Conversion Using Piezoelectric Materials -  
*Fantasy or Reality?***

Ralph Zee  
Auburn University  
(334)844-3320, rzee@eng.auburn.edu

Presented at the Prospector IX Workshop, Durham, NC  
November 3, 1997

# Background

What is piezoelectricity?

Mechanical deformation  $\leftrightarrow$  Electricity

Requires ferroelectric materials.

Some history: Discovered 100 years ago by the Curie brothers

Piezo: Greek for “pressure, press”.

What are some of the piezoelectric materials?

Ceramics: PZT (lead zirconate titanate)

Polymer: PVDF, Polyvinylidene fluoride, polarized fluoropolymer discovered in 1969 by Kawai.

What are piezoelectric materials commonly used for?

Sensors!!!



# Pros and Cons of Polymeric Piezoelectric Films

Pros	Cons
<ul style="list-style-type: none"> <li>(1) Ease of fabrication.</li> <li>(2) Low costs.</li> <li>(3) Wide frequency response range: milliHz to GHz.</li> <li>(4) Large dynamic response range: <math>10^{-8}</math> to <math>10^6</math> psi.</li> <li>(5) High voltage output.</li> <li>(6) High mechanical strength and ductility.</li> <li>(7) Impact resistance.</li> <li>(8) High dielectric strength.</li> <li>(9) High electrical resistivity.</li> </ul>	<ul style="list-style-type: none"> <li>(1) Low temperature operation (100°C max)</li> <li>(2) Sensitive to electromagnetic radiation.</li> <li>(3) Relatively low dielectric constant (&lt;100).</li> <li>(4) Relatively low capacitance.</li> <li>(5) Low electromechanical transmission.</li> <li>(6) High electrical resistivity.</li> </ul>

## Physical parameters of PVDF and PZT

Physical Properties	PVDF	PZT
Density (gm/cc)	1.78	7.5
Dielectric Constant	12	1,200
Max operating field (kV/mm)	10	0.3
Piezoelectric strain constant, $d_{31}$ ( $10^{-12}$ C/N)	23	110
Piezoelectric strain constant, $d_{33}$ ( $10^{-12}$ C/N)	36	250
Piezoelectric voltage constant, $g_{31}$ ( $10^{-3}$ V-m/N)	216	10
Piezoelectric voltage constant, $g_{33}$ ( $10^{-3}$ V-m/N)	339	25
Yield Stress ( $N/m^2$ )	$4 \times 10^8$	$5 \times 10^7$
Elongation at Yield (%)	3	0.08
Young's Modulus ( $N/m^2$ )	$2.5 \times 10^9$	$8 \times 10^{10}$
Tensile Strength at Break ( $N/m^2$ )	$2 \times 10^8$	$5 \times 10^7$
Elongation at Break (%)	27	0.08
Max operating temperature ( $^{\circ}C$ )	100	150

## **Attempts to produce electricity from this stuff?**

**Sneakers?**

**Breathing action of human?**

**Heart motion?**

**Compression from bone joint? ( $17\mu\text{W}/\text{joint}$  obtained, estimated  $10\text{mW}/\text{gm}$  possible)**

**What are the limits of this concept?**

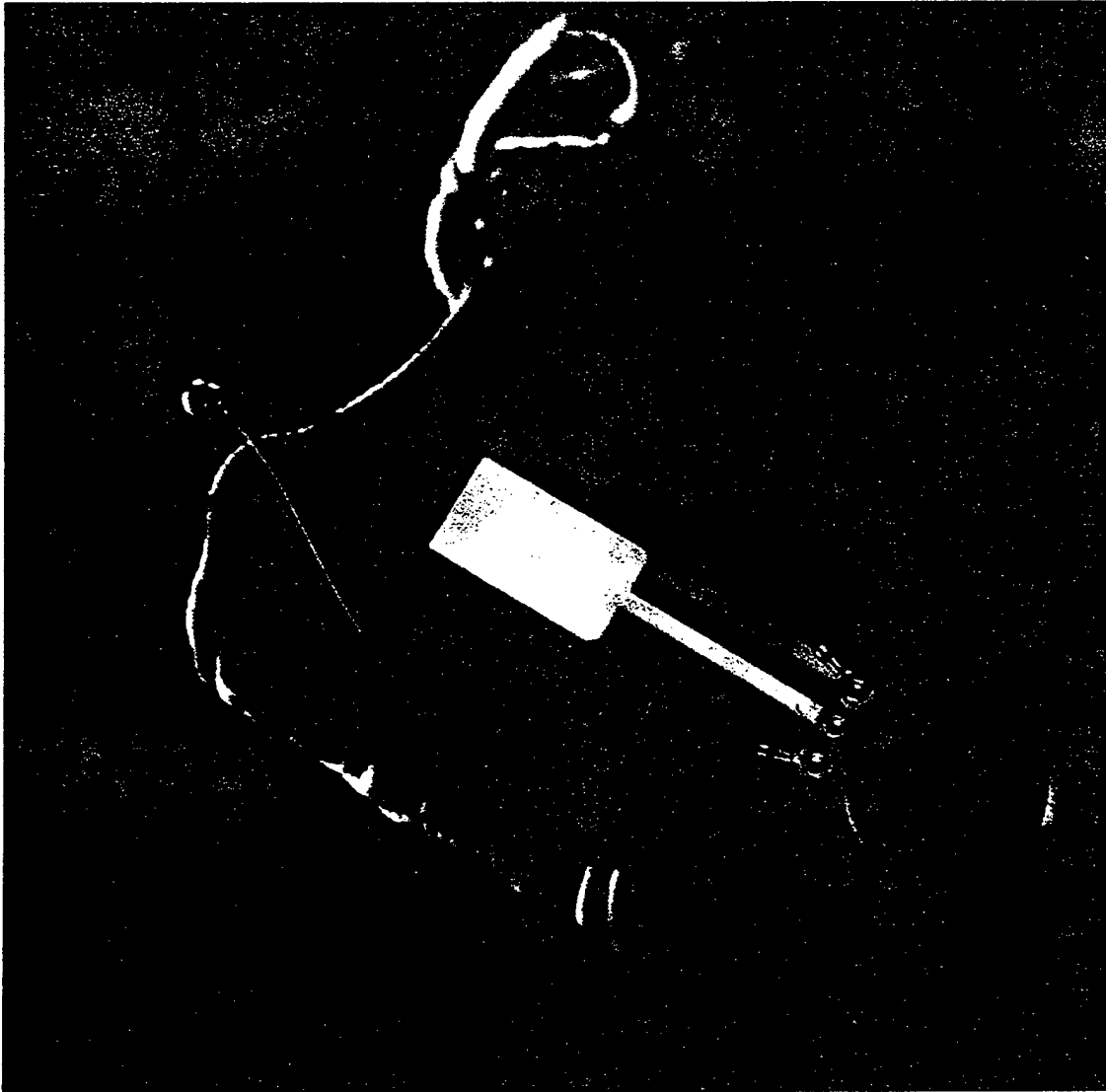

**Two modes of operation for power conversion:** Power generated in the thickness direction with stress applied in the same direction or along the length.

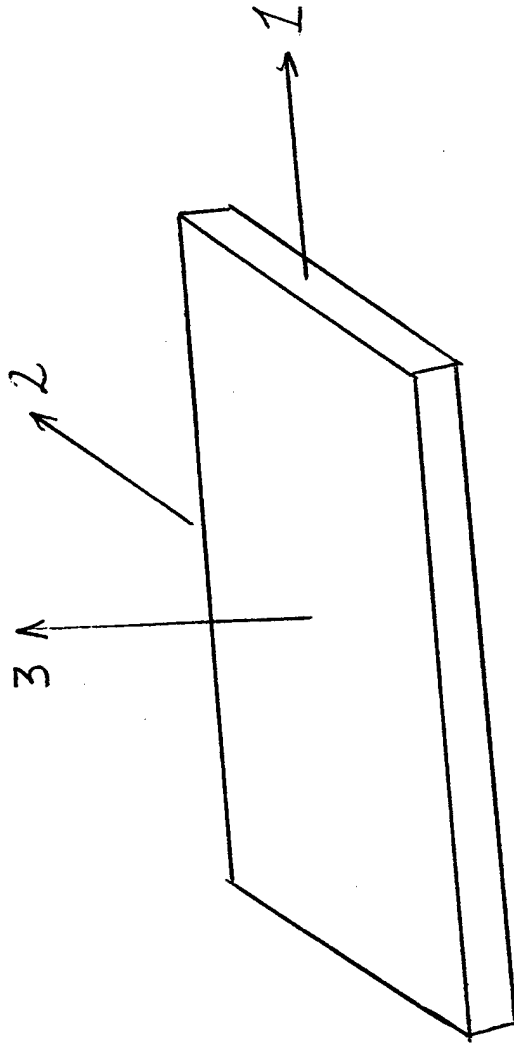

## First Mode of Operation: 33 mode

$$Q = d_{33}A\sigma$$
$$V = g_{33}t\sigma$$

$Q$  is the charge produced,  
 $V$  is the voltage generated,  
 $t$  and  $A$  are the thickness and the surface area of the film,  
 $\sigma$  is the applied stress

$$E = \frac{1}{2} d_{33} g_{33} A t \sigma^2$$

Using  $A = 10\text{cm}^2$  and  $t = 0.5\text{cm}$  (multilayer stacked together)  
a walking rate of 1 step per second  
force from a 180lb body giving a normal stress of  $8 \times 10^5 \text{ N/m}^2$ :

$$P = 0.02\text{mW}$$

## Second Mode of Operation: 31 mode

$$Q = d_{31} A \sigma$$
$$V = g_{31} t \sigma$$

$$E = \frac{1}{2} d_{31} g_{31} A t \sigma^2$$

Using  $A = 1.58 \text{ cm}^2$  and  $t = 3.16 \text{ cm}$  (multilayer stacked together) a walking rate of 1 step per second and force from a 180lb body giving a normal stress of  $5 \times 10^6 \text{ N/m}^2$ :

$$P = 0.3 \text{ mW}$$

## Theoretical Limit of Power Production

Yield stress is  $5 \times 10^8 \text{ N/m}^2$ , Yield strain is 3%

Assume applied stress is 40% of yield =  $2 \times 10^8 \text{ N/m}^2$  or 200 MPa

Mechanical Energy Available =  $\frac{1}{2} \sigma \epsilon = 1000 \text{ kJ/m}^3$

Energy per activation (step) =  $\frac{1}{2} d_{33} g_{33} A \sigma^2$  for the 33 mode  
=  $240 \text{ kJ/m}^3$  or  $0.24 \text{ J/cm}^3$  or  $0.13 \text{ J/gm}$

Conversion Efficiency = 24% for the 33 mode

Energy per activation (step) =  $\frac{1}{2} d_{31} g_{31} A \sigma^2$  for the 31 mode  
=  $100 \text{ kJ/m}^3$  or  $0.1 \text{ J/cm}^3$  or  $0.056 \text{ J/gm}$

Conversion Efficiency = 10% for the 31 mode

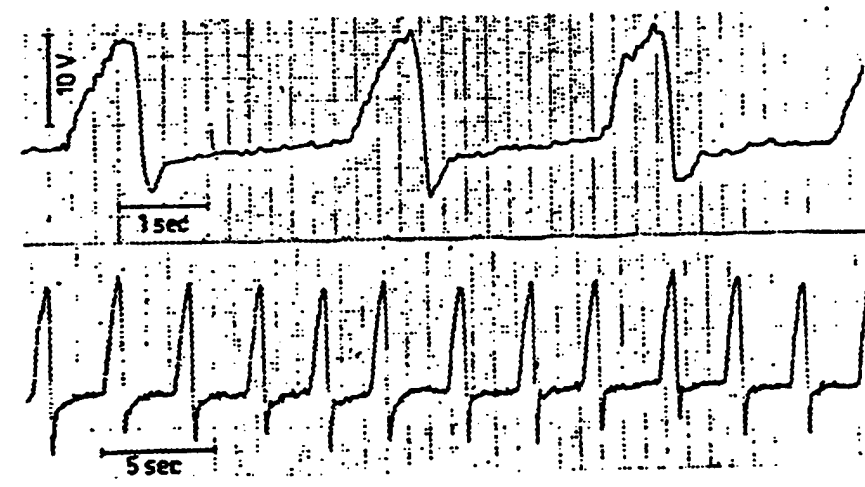
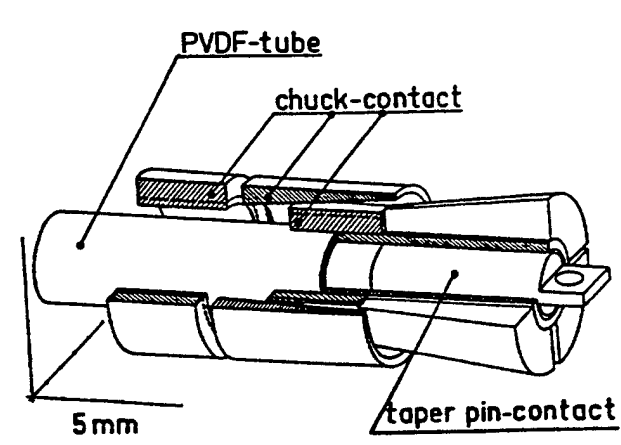
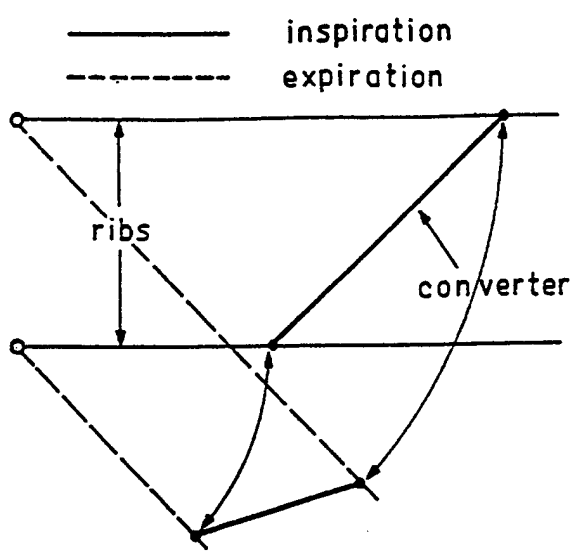

## **Issues to be addressed**

- (1) Efficiency is high.
- (2) How does one generate the high stress needed?
- (3) Work with the geometry due to the stress square dependence.
- (4) Incorporation into human systems.
- (5) Circuit design and power conditioning.



**“ELECTROCHEMICAL CAPACITORS”**

**Dr. Stephen A. Merryman**

**Space Power Institute  
Auburn University, AL 36849**



---

# Electrochemical Capacitors

Stephen A. Merryman  
Auburn University

Presented at Prospector IX Workshop on  
Human Powered Systems and Technologies  
November 2-5, 1997  
Durham, NC

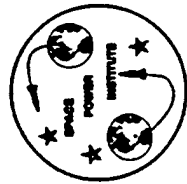

# Classification of Electrochemical Capacitors



- ★ By Electrode Type
  - » Activated Carbon Powder
  - » Carbon/Metal Fiber
  - » Activated Synthetic Carbon
  - » Doped Conducting Polymer Films on Carbon Cloth
  - » Mixed Metal Oxides Deposited on Metal Foils
- ★ By Electrolyte Type
  - » Aqueous
  - » Organic
  - » Solid
- ★ By Energy Storage Mechanism
  - » Double Layer Capacitance
  - » Pseudocapacitance

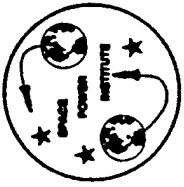

# Key Capacitor Characteristics



- ★ Energy Density
  - » Gravimetric
  - » Volumetric
- ★ Capacitance Density
  - » Gravimetric
  - » Volumetric
- ★ Equivalent Series Resistance (ESR)
- ★ Equivalent Parallel Resistance (EPR)

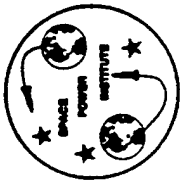

## Internal Resistance



- ★ Equivalent Series Resistance (ESR) determines the internal losses of the capacitor during cycling.
  - » Want ESR minimized
- ★ Equivalent Parallel Resistance (EPR) determines the leakage current or self-discharge of the capacitor.
  - » Want EPR to be large

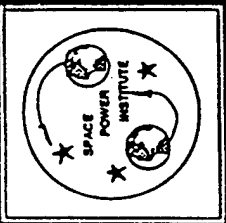

### Approximate Electrolyte Conductivities

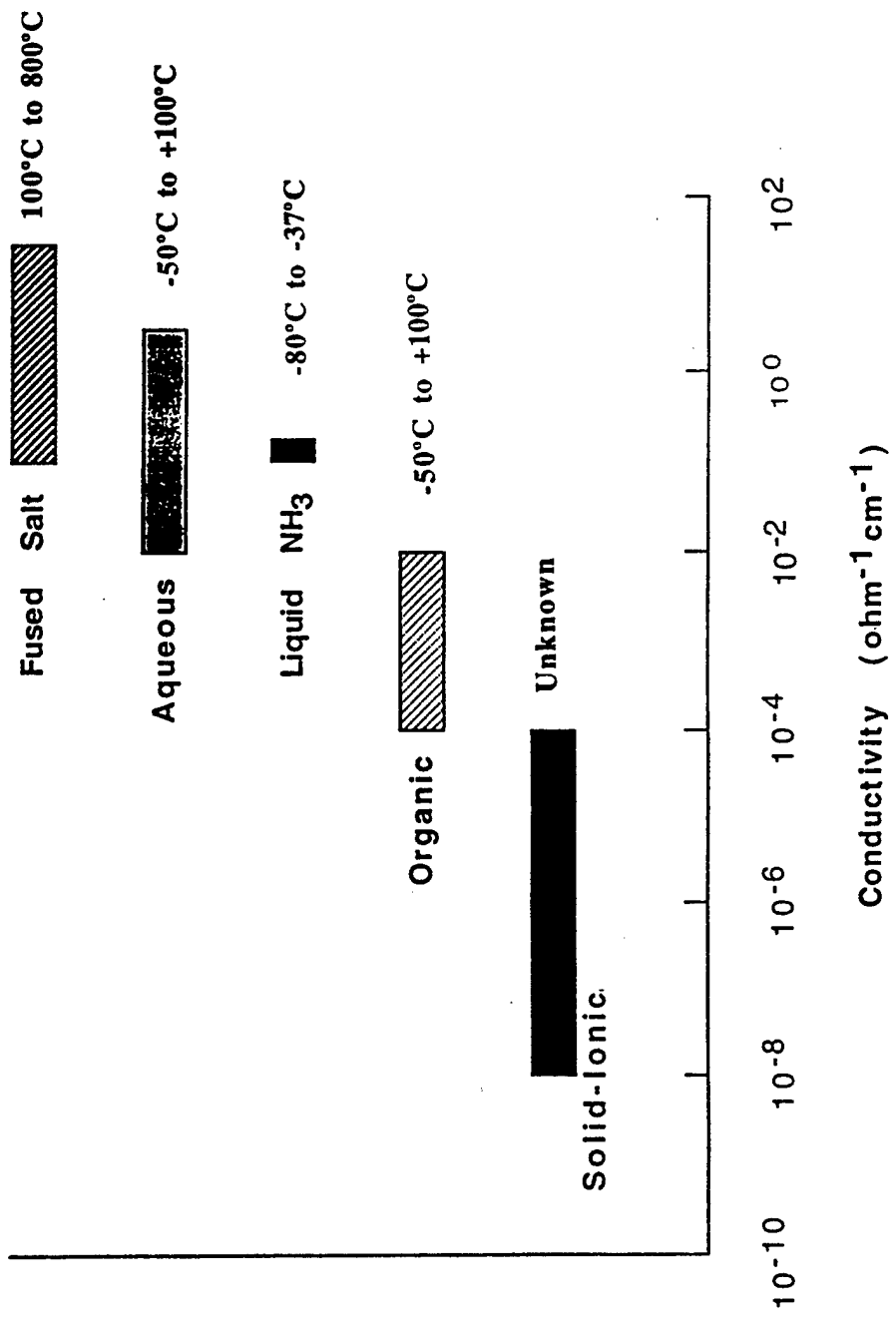

# Electrochemical Capacitors

- ★ Highest demonstrated energy storage density for capacitive storage.
- ★ Demonstrated power densities much greater than battery technologies.
- ★ Greater than 1,000,000 charge/discharge cycles have been demonstrated.
- ★ Exhibit non-explosive failure modes.
- ★ Can be customized for a particular application.

# Rechargeable Power Sources

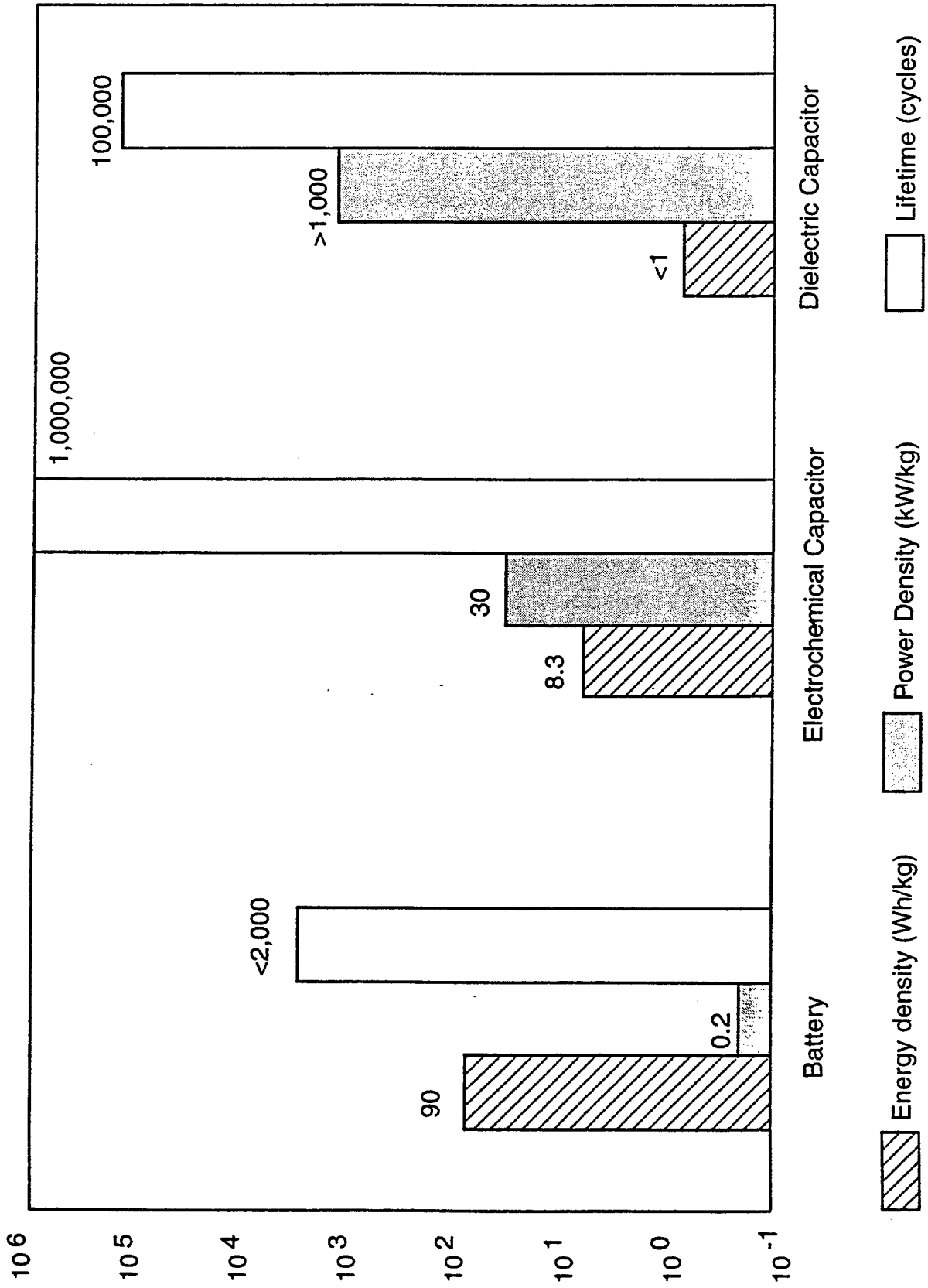

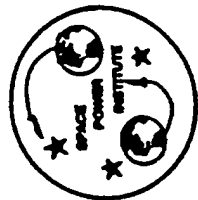

# State-of-the-Art in Electrochemical Capacitors

## STATE-OF-THE-ART ELECTROCHEMICAL CAPACITORS

	Capacitance <sup>(1)</sup> density (F/g)	Energy <sup>(2)</sup> density (Wh/kg)	Power <sup>(2)</sup> density (kW/kg)	Problems
DOE goal		>5	>1	
Carbon/aqueous	42	2.66	: 2.4	the operating voltage is low (0.6-0.8 V)
Carbon/organic	21	5.1	1.6	the ionic conductivity is low (< 30 mS/cm)
RuO <sub>2</sub> film	95	4.7	7	low package efficiency, high cost
RuO <sub>2</sub> .xH <sub>2</sub> O	192	8.3	> 30	high cost

- (1) only electrode material was counted.
- (2) electrode and electrolyte were counted.

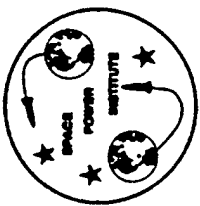

# Double Layer Capacitance



- ★ Helmholtz discovered that the interface between a conductor and electrolyte was capable of storing charge.
- ★ Layer is estimated to be approximately  $10\text{\AA}$  thick.
- ★ Use of large surface area materials ( $1500\text{ m}^2/\text{g}$ ) enables multi-farad capacitors to be constructed.



# CHEMICAL DOUBLE LAYER CAPACITOR CARBON-AQUEOUS

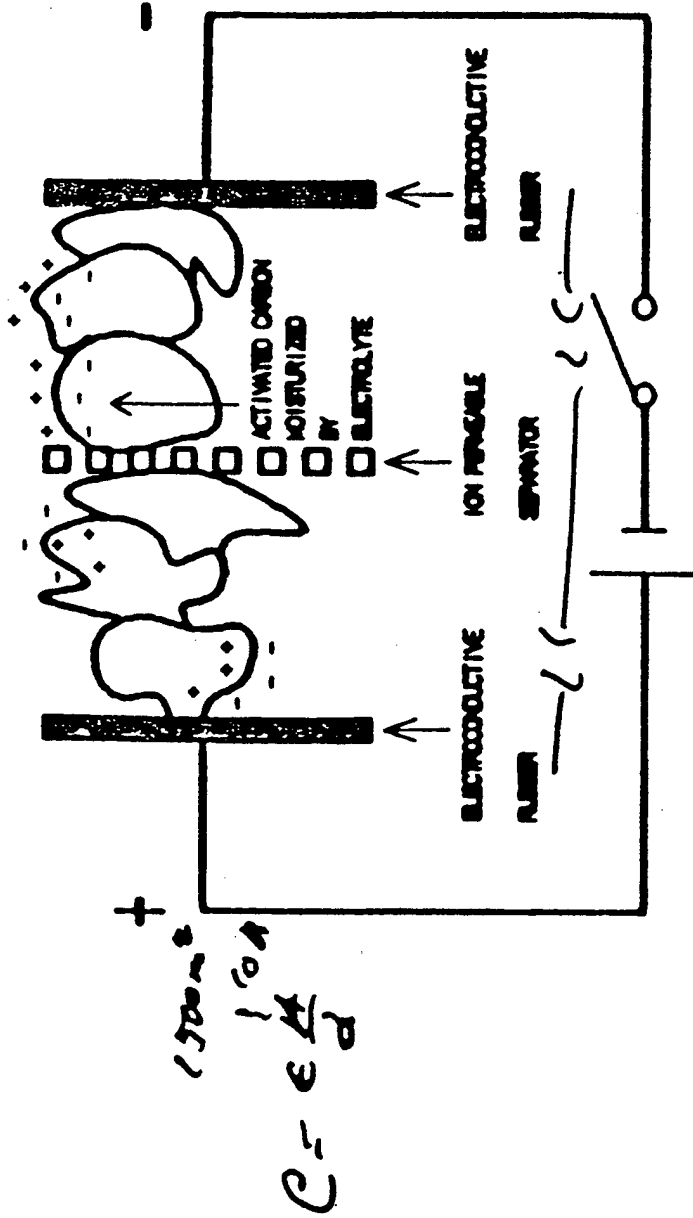

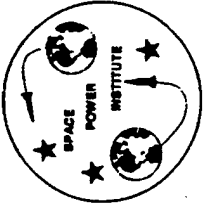

# Composite Electrode Structure



- ★ Eliminate the need for pressure to obtain low values for the equivalent series resistance (ESR).
- ★ Uniform electrode structure using standard paper-making techniques with metal and carbon fibers with a cellulose binder.
- ★ Reaction sequence removes the binder while bonding the metal fibers and foil.

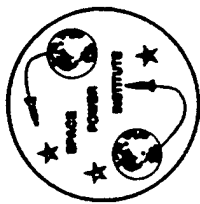

# Composite Electrode Structure

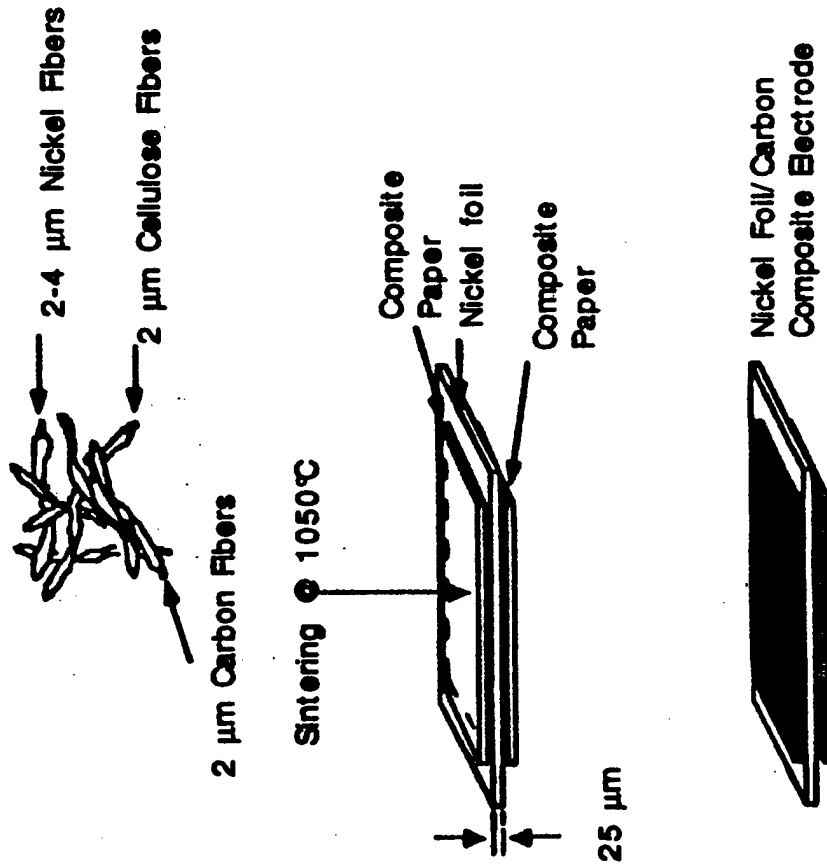



# Composite Fiber Structure

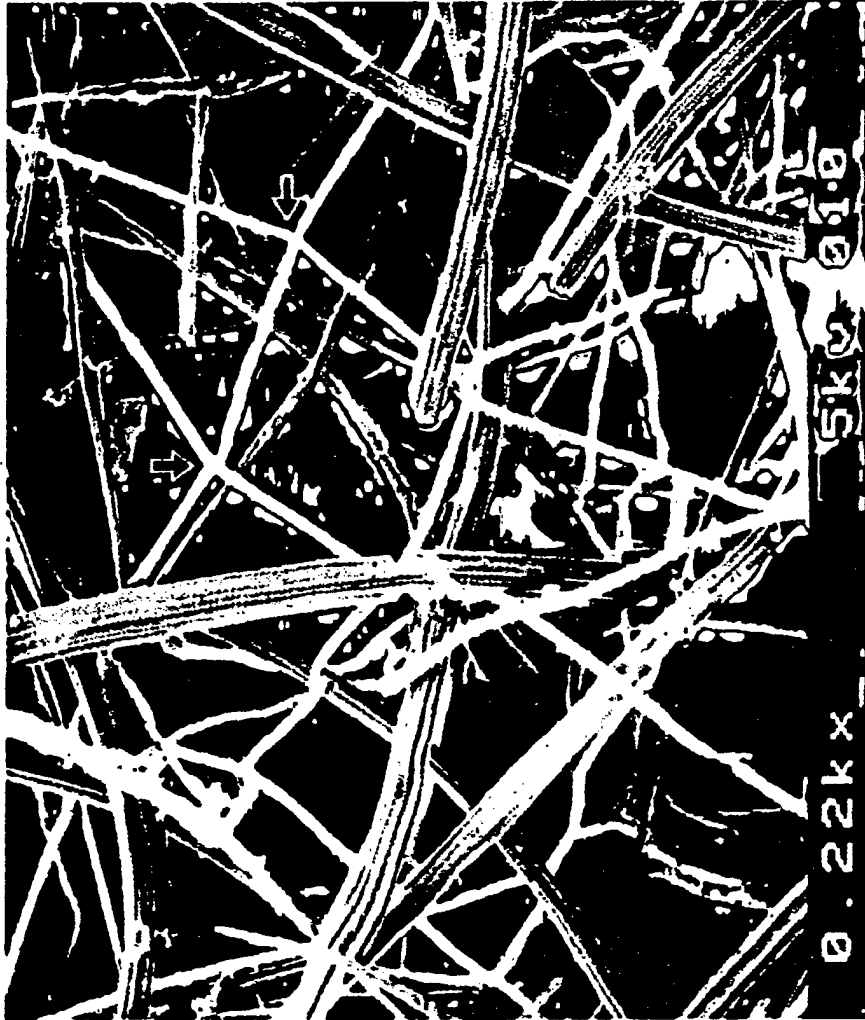
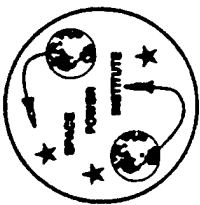

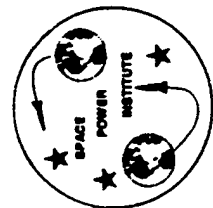

# ESR Pressure Dependence

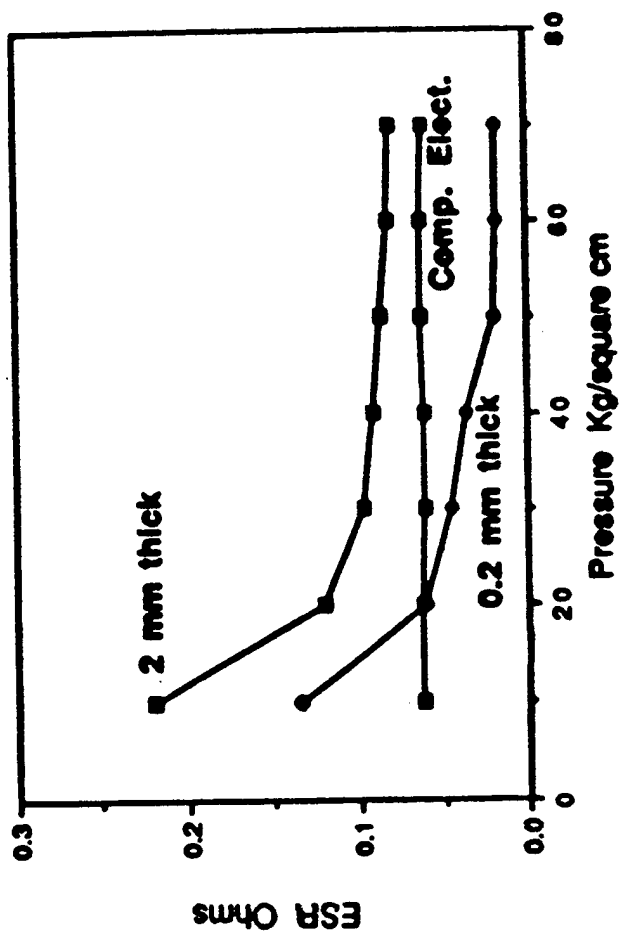

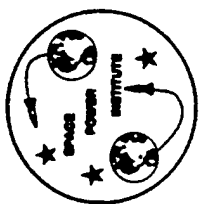

# 270-V, 0.8 F Capacitor Bank

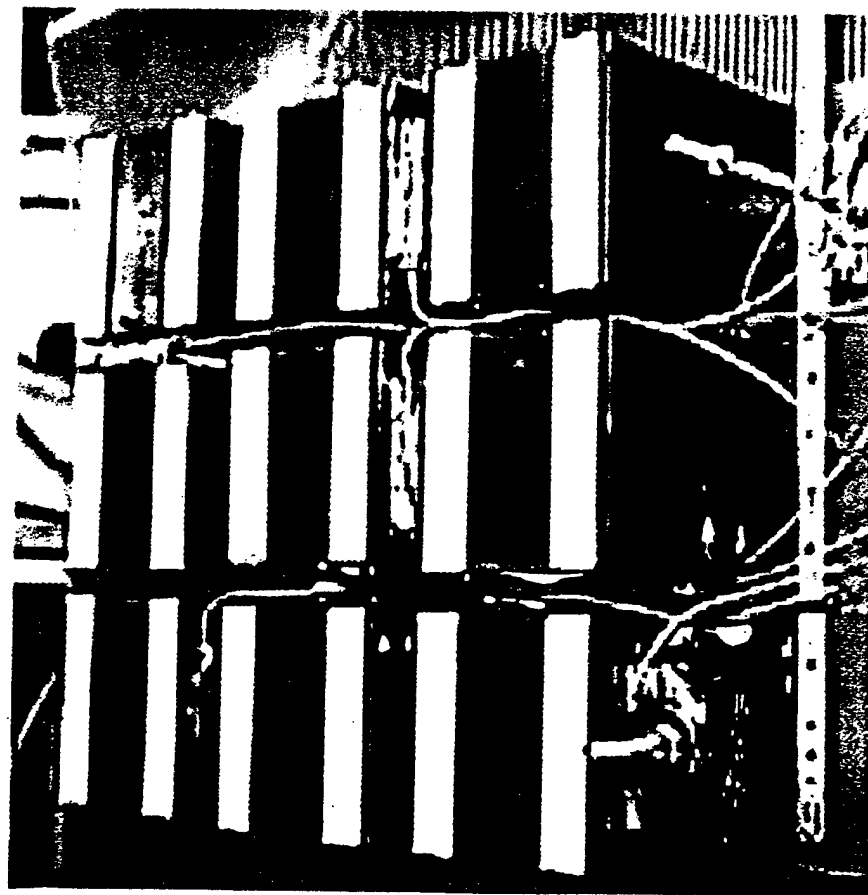

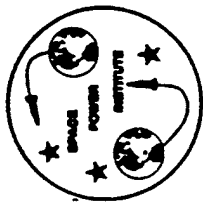

# Temperature Dependence

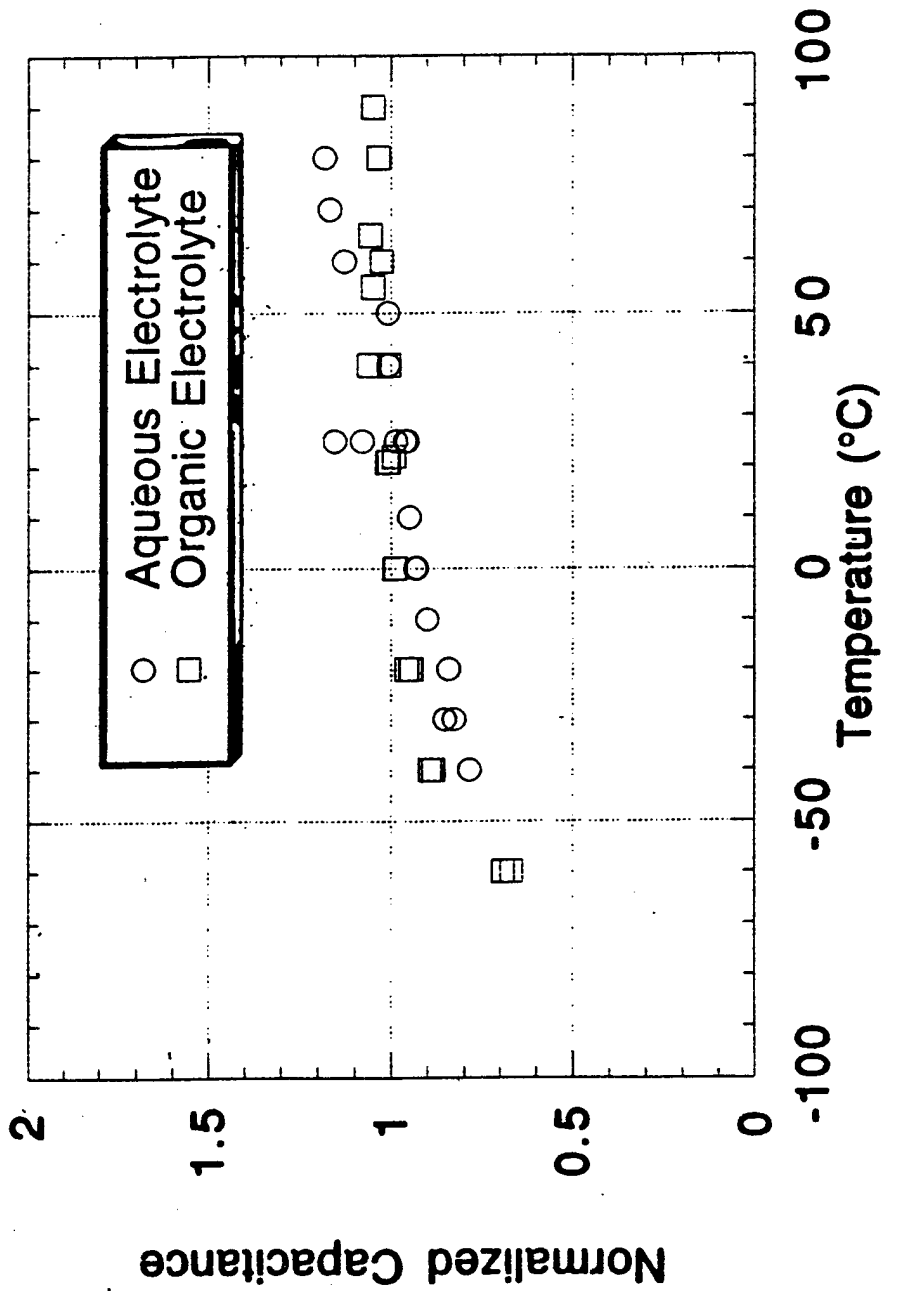

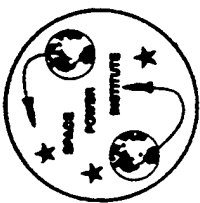

# Temperature Dependence

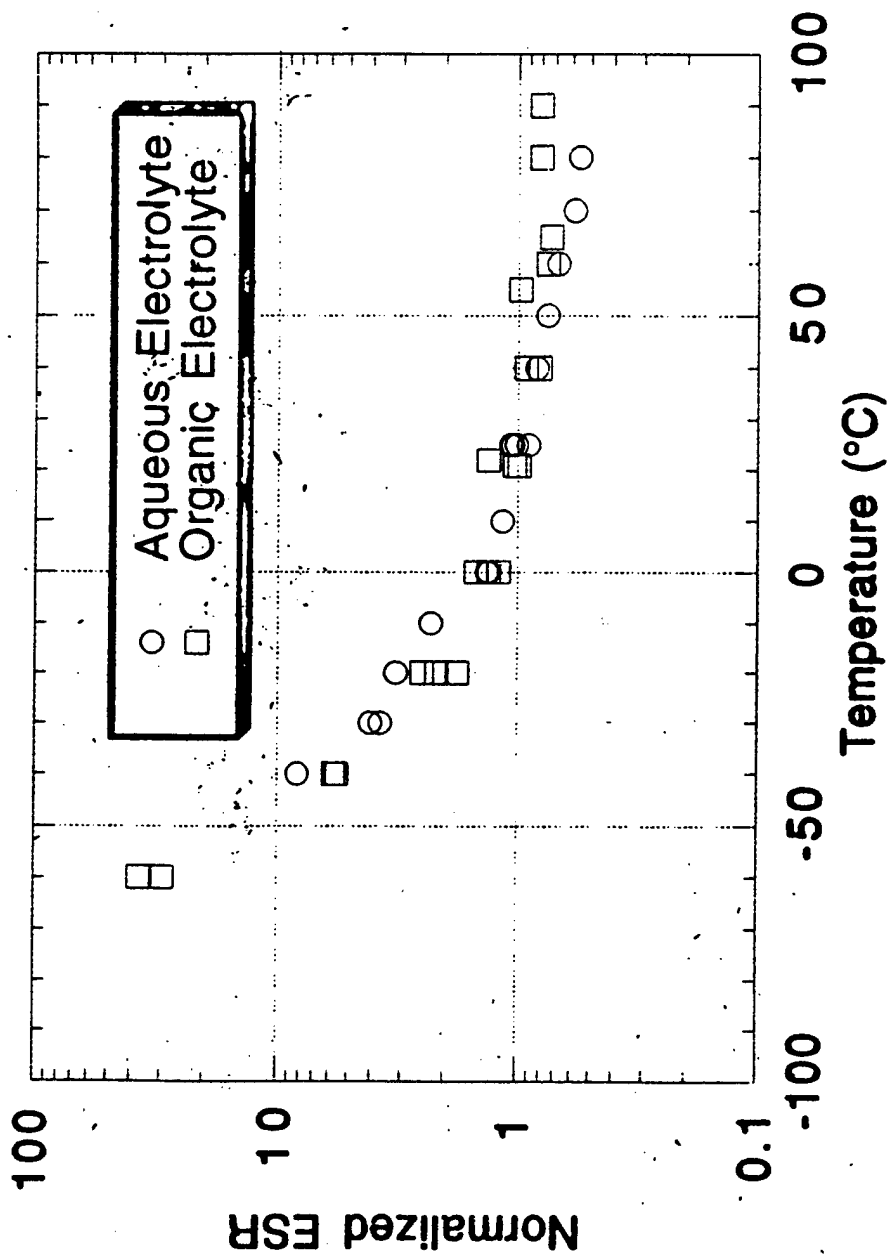
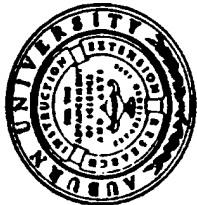

# Pseudocapacitance

- ★ Energy is stored electrochemically rather than electrostatically.
- ★ Involves surface reactions with hydrogen ions and is essentially due to proton intercalation into the surface of the active material.
- ★ Redox Reaction
  - $\text{RuO}(\text{OH}) \leftrightarrow \text{RuO}_2 + \text{H}^+ + \text{e}^-$
- ★ Much higher charge density than double layer capacitor.

# Mechanism of Redox Capacitance of $\text{RuO}_2 \cdot \text{H}_2\text{O}$

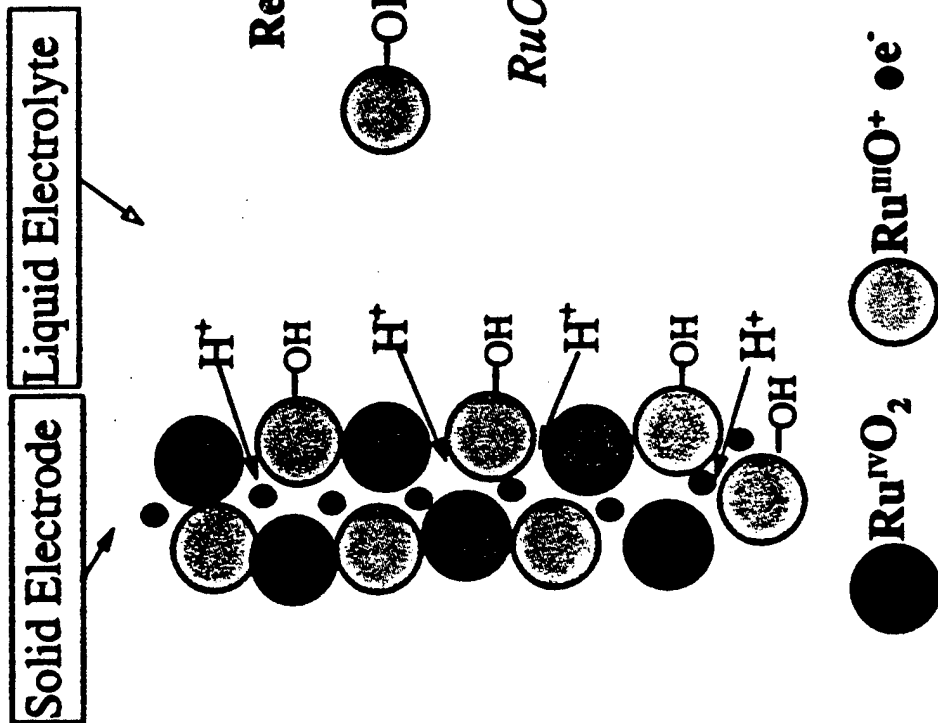

## Benefits:

- \* Volumetric redox
- \* Surface redox
- \* Surface double-layer

## Key factors:

- \* Amorphous hydrated structure
- \* Sufficient protons
- \* Mixed ionic states, e.g.  $\text{Ru}^{\text{III}}$ ,  $\text{Ru}^{\text{IV}}$ , etc.

## Result:

Redox capacitor has 10 time higher storable charge-density than double-layer capacitor

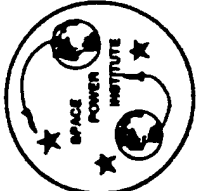

# PSEUDOCAPACITOR

## METAL OXIDE WITH SOLID OR LIQUID ELECTROLYTE

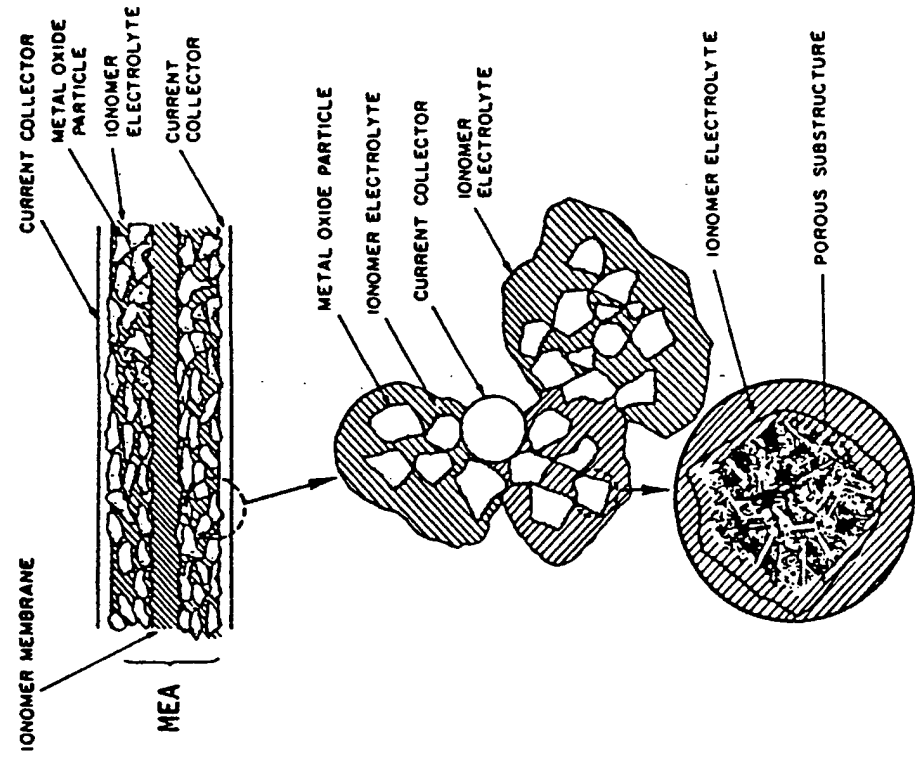

# UNIQUE HYDRO-RUTHENIUM OXIDE CAPACITOR AND ITS COMPARISON

## THE UNIQUENESS

- \* The Highest Specific Energy, 100 J/g
- \* The Highest Specific Power, >30 kW/kg
- \* Inexpensive Material Processing Technology
- \* Using Well Established CDL Fabrication Technology
- \* Long Lifetime
- \* Improved Frequency Dependence

## COMPARISON

Capacitor	Electrolyte	Capacitance Density* F/g	Specific Capacitance F/g	Specific Energy** Wh/kg(J/g)	Specific Power** kW/kg
Activated Carbon	Organic	21	50	5.1(18.4)	1.6
Activated Carbon	Aqueous	42		2.7(9.7)	0.24
Crystal RuO <sub>2</sub>	Aqueous	95	380	4.7(16.9)	
Amorphous RuO <sub>2</sub>	Aqueous	195	1000	8.3(29.9)	>30

\* Only electrode material was counted.

\*\* Electrode and electrolyte were counted.

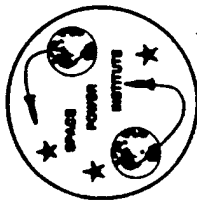

# RuO<sub>2</sub> Supercapacitor Technology



- ★ **Hydrous RuO<sub>2</sub> chemistry**
  - » With industrial partner
  - » Aqueous electrolyte
  - » Requires amorphous RuO<sub>2</sub>
  - » Redox capacitance mechanism
- ★ **Comparisons**
  - » Specific capacitance: 1 F/mg (20x organic carbon)
  - » 30 j/g specific energy (3x aqueous carbon)
  - » >30 kW/kg specific power (100x aqueous carbon)
- ★ **Processing**
  - » Uses inexpensive CDL fabrication process

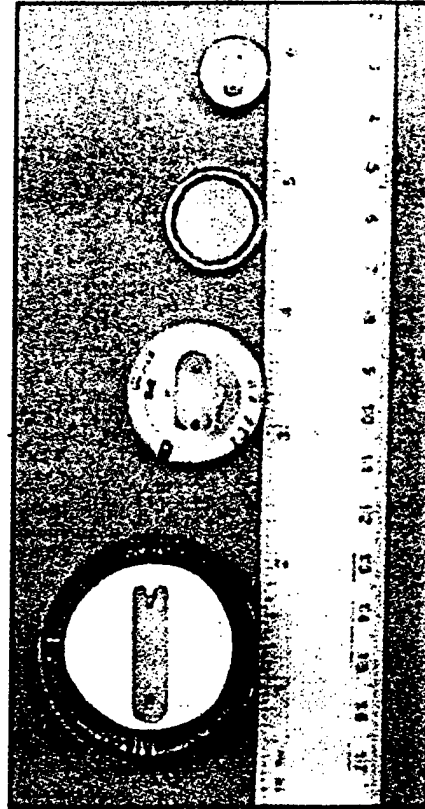

12.6 V	6.0 V	1.8 V	3.3 V
1.3 F	1.3 F	1.0 F	0.1 F

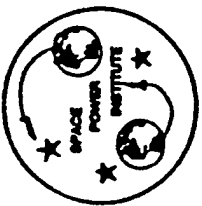

# Capacitance (•) and ESR (◦) as Function of Temperature

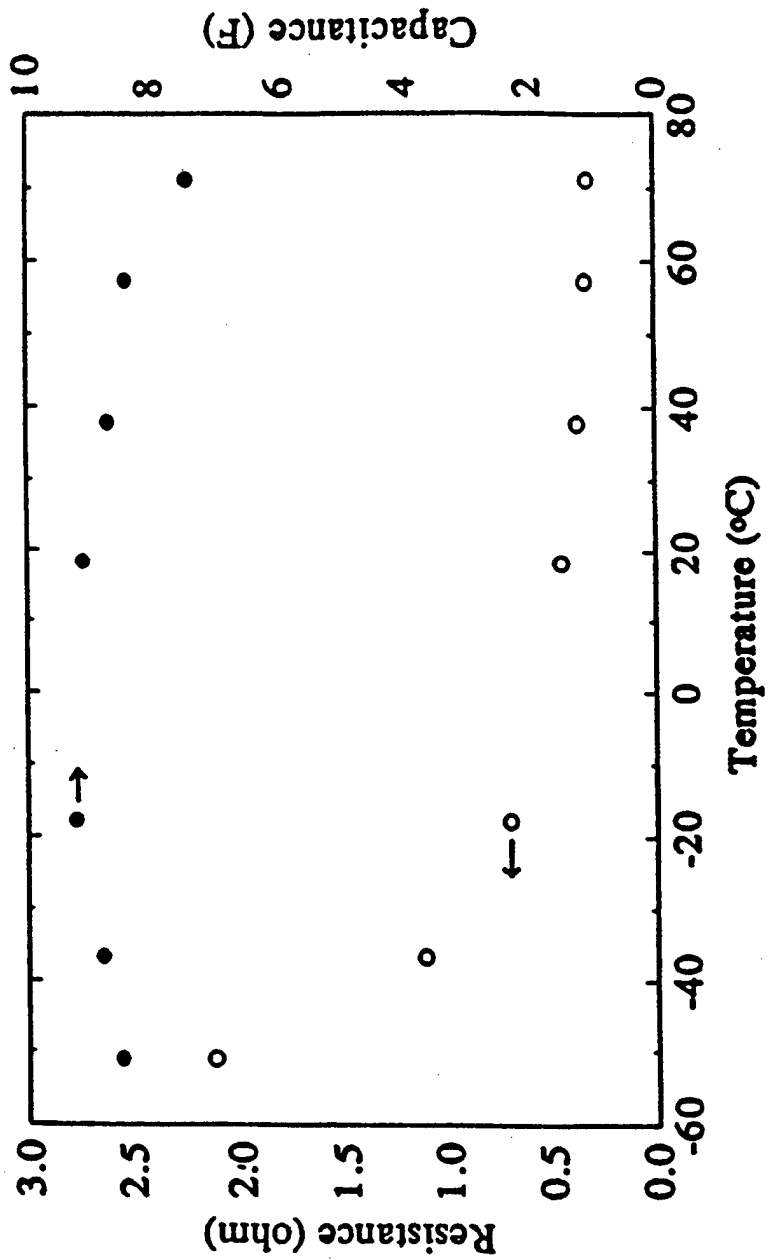

SPACE POWER INSTITUTE

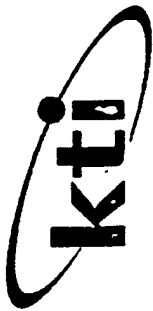

# KTI Cap Cycle Testing

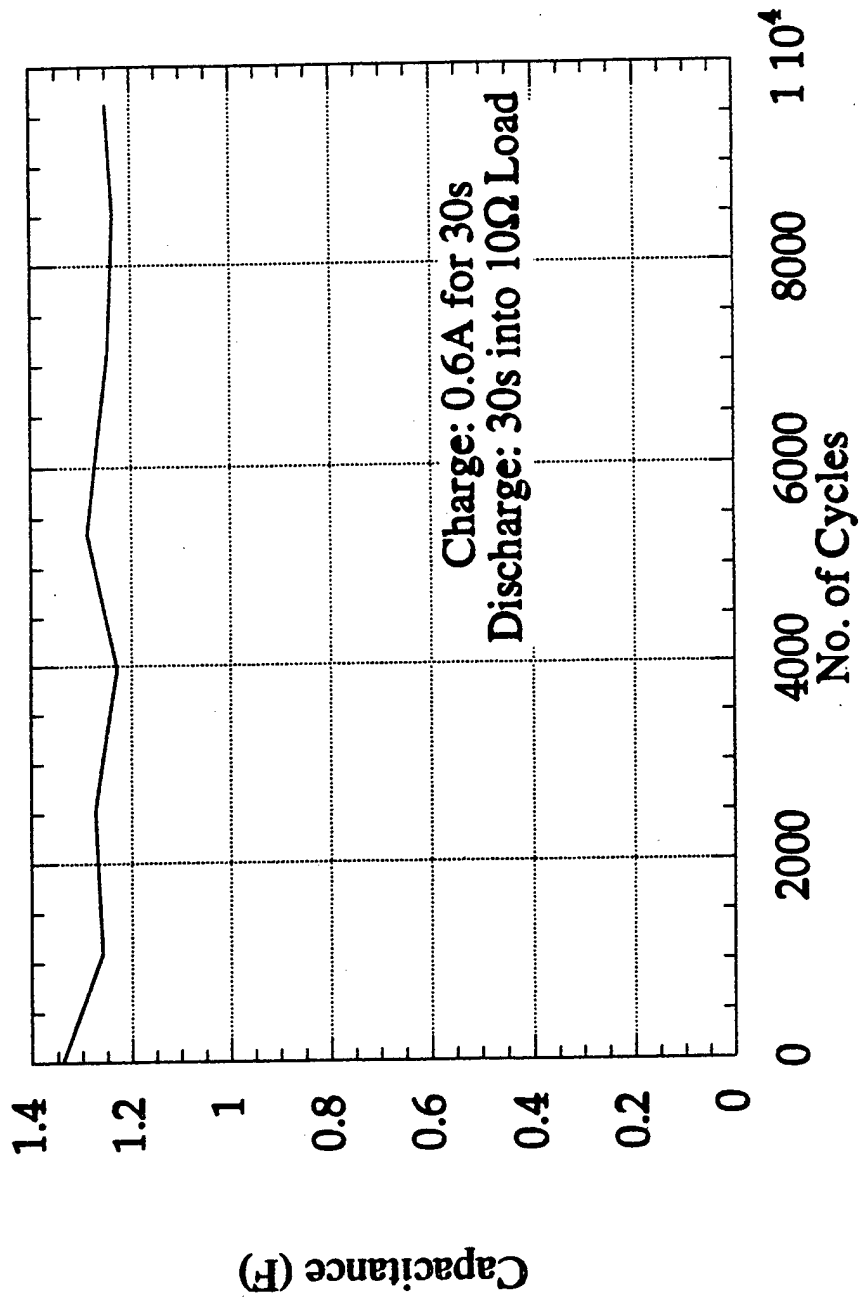

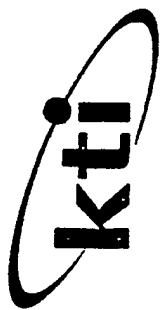

# KTICap Cycle Testing

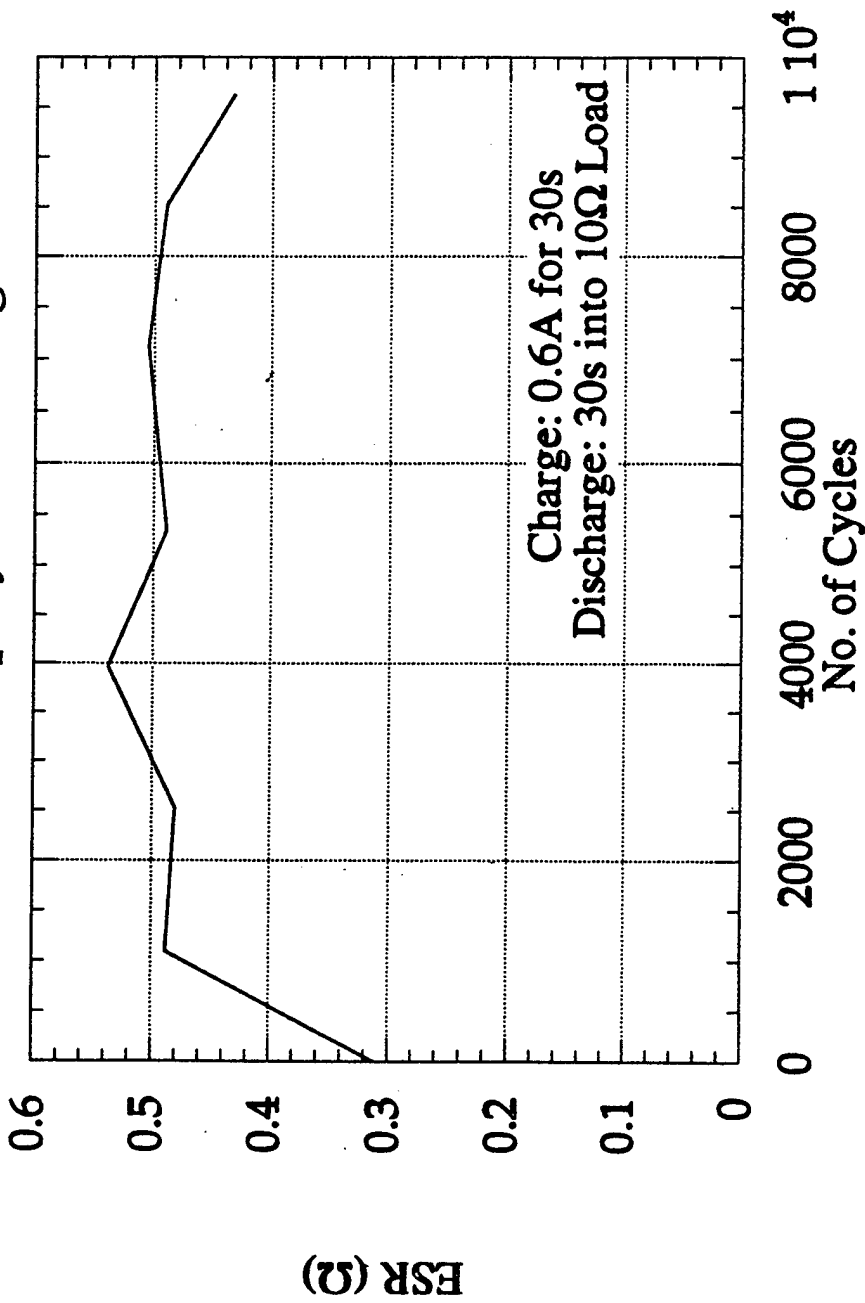

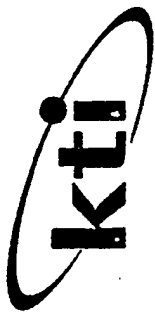

Lifetime as Function of Power Density

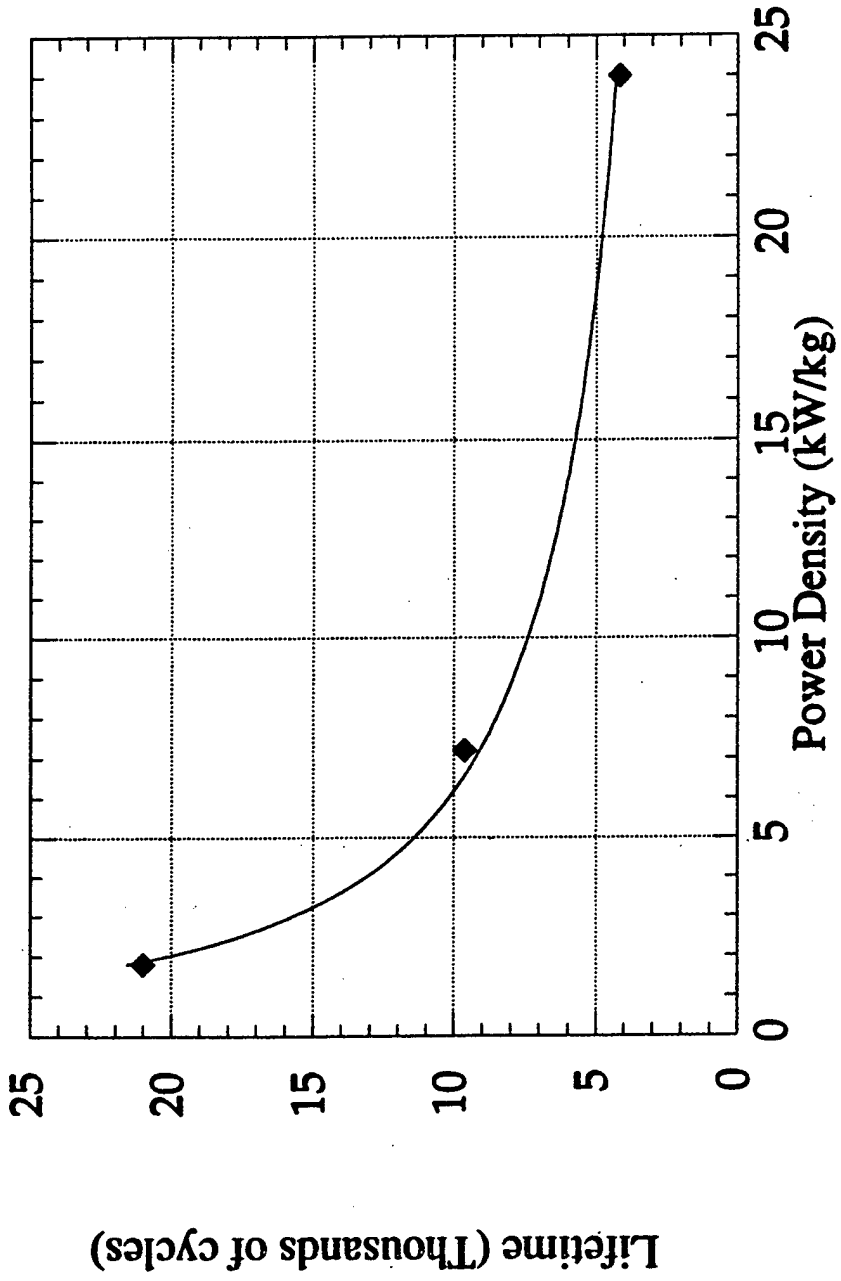



# Energy Density vs. Power Density for Electrochemical Capacitors Made with Different Materials

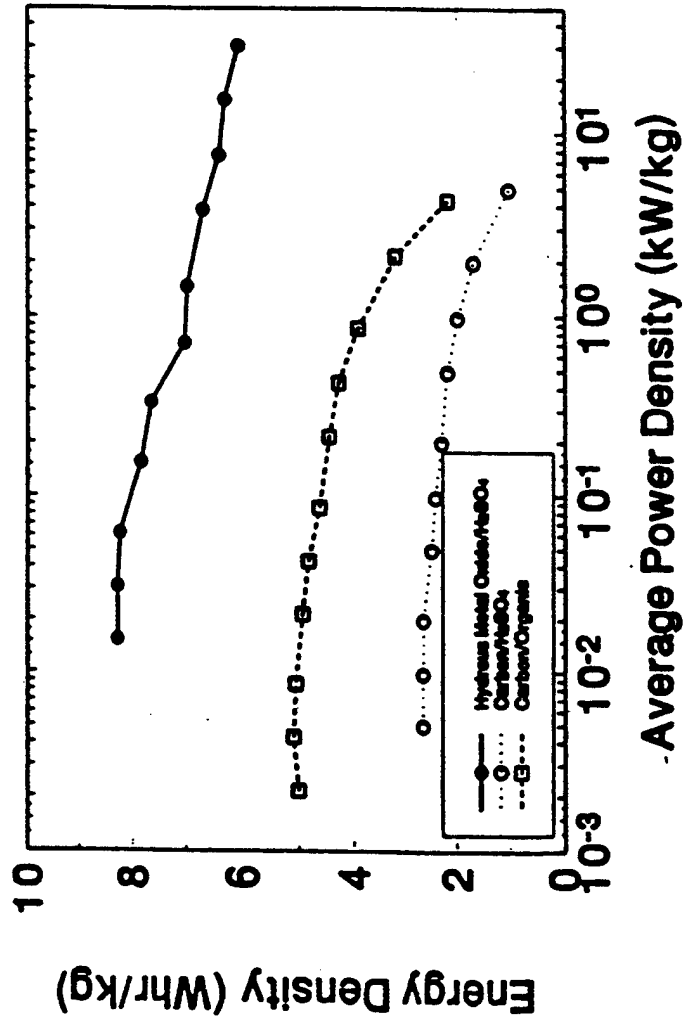

ANL Document SPACE POWER INSTITUTE

Summary of Capacitor Technology

Name	Construction			Performance						Status		
	Electrode Configuration	Electrolyte	Energy (kJ/kg)	Density (kJ/l)	Resistance ( $\Omega\text{-cm}^2$ )	Max. Power	Cost	Voltage	Typical Capacitance (F)	Largest Unit	Basis for Projection	NASA Readiness Level
NEC Supercap	bipolar carbon/carbon composite	sulfuric acid	4.7	6.8	.16	4 kW/kg	low	15	470	55 kJ	Manufacturer's spec sheet	6
NEC FY	bipolar carbon	sulfuric acid	1.2	1.98	45	—	low	5	2.2	—	Manufacturer's spec sheet	6
NEC FE	bipolar carbon	sulfuric acid	0.036	0.65	1.9	—	low	5	1.5	—	Manufacturer's spec sheet	6
Panasonic	spiral wound, single cell carbon	organic	7.9	10.4	7	2.7 kW/kg	low	3	470, 1500	6.7 kJ	Commercial device	6
Evans	prismatic carbon	sulfuric acid	0.72	1.8	1	—	low	11	—	40 kJ	Manufacturer's spec sheet	5
Seiko Instruments	polyacene polymer, button cell	organic	6.84	17.6	12	—	—	5	2.5	—	Manufacturer's spec sheet	6
Pinnacle Research Institute	bipolar pseudocap using mixed oxides (Ru, Ta)	sulfuric acid	18	50.4	<10 <sup>-2</sup>	2 kW/kg	high	100	0.01	15 kJ	Manufacturer's testing	5/6
Maxwell/Auburn	bipolar carbon/metal composite	KOH	4.32	7.2	0.1 - 0.2	1.7 kW/kg	med	28	12	6 kJ	Engineering prototypes	5/6
SAFT	bipolar carbon	organic	22	32.4	1.5	3 kW/kg	med	3	2700	12.5 kJ	Engineering prototype	5/6
ARL/Army	Bipolar hydrous RuO <sub>2</sub>	sulfuric acid	10.4	15.8	15	1.2 kW/kg	low	3	175	—	Lab cell	4
<b>KTI</b>			96	187	—	10 kW/kg	high	5	2.72	34 J		
Livermore	bipolar aerogel carbon particulate	KOH	3.6	5.4	—	—	med	1	35	—	Lab cells	4
National Lab	bipolar synthetic, activated carbon	aqueous	5.0	6.1	0.35	1 kW/kg	med	1	3.5	—	Lab cells	4
Sandia	bipolar conducting polymer on carbon	solid organic	36-72	—	—	—	low	—	—	—	Projections	—
Los Alamos	bipolar pseudocap, Ag-anode, C-cathode	solid RbAg <sub>4</sub> I <sub>5</sub>	1.98	12.6	ohms	—	—	0.6	—	—	Manufacturer's testing	6

# Summary/Conclusions

---

---

- ★ Electrochemical capacitors are high specific power and energy devices.
- ★ Electrochemical capacitors are capable of hundreds of thousands of charge/discharge cycles.
- ★ Electrochemical capacitors can be configured to meet the needs/requirements of human powered systems.

**“COMPACT AND LIGHTWEIGHT ENERGY CONVERSION  
USING ELECTROSTRICTIVE POLYMERS”**

**Mr. Roy D. Kornbluh**

**SRI International  
Menlo Park, CA 94025**

---

# ***Compact and Lightweight Energy Conversion using Electrostrictive Polymers***

Presentation to  
Prospector IX Human Power Systems Workshop  
Roy Kornbluh  
Ron Pelrine  
SRI International  
November 1997

---

SRI International



# ***Problem Statement***

---

- Develop a device that can efficiently convert human motion into useful amounts of electrical power with minimal mass, volume, and discomfort to the wearer.

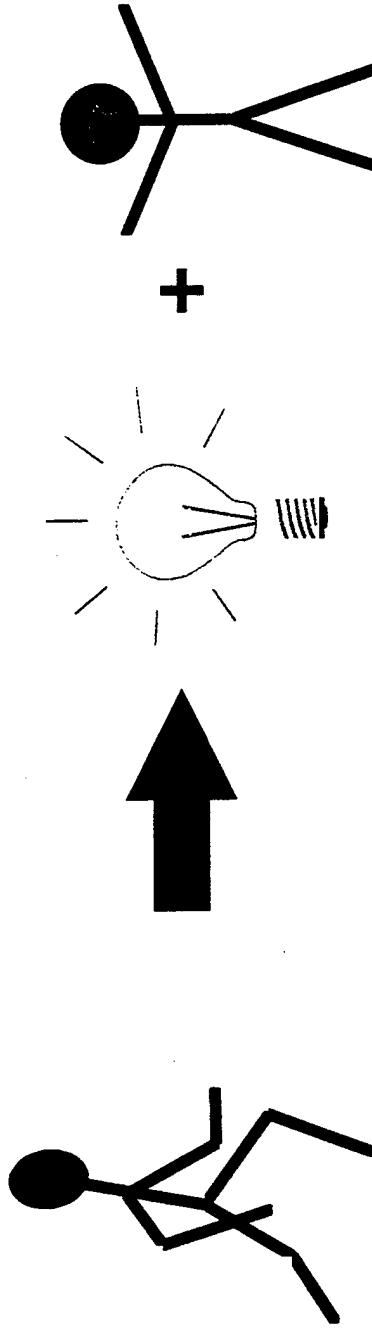

# ***Technical Challenges***

---

- Determine how human motion can be harvested without placing excessive burden on the wearer
- Develop an energy conversion technology that:
  - is efficient
  - has high energy density (to minimize volume)
  - has high specific energy (to minimize mass)
  - is impedance matched to human movement
    - large stroke
    - moderate forces
  - is rugged and reliable
  - can function over a range of environmental conditions
- Store and manage the generated power

# Harvesting Human Movement

---

- Several possibilities that do not excessively burden the wearer

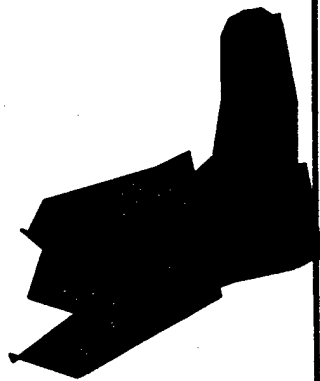

HEEL STRIKE AND SHOE FLEXURE  
2 - 20W

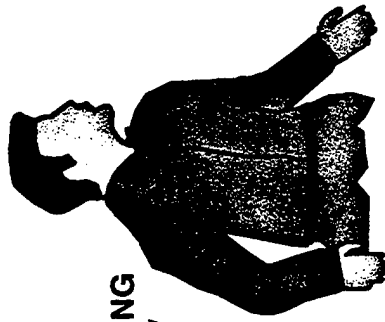

LIMB SWING  
0.2-3W

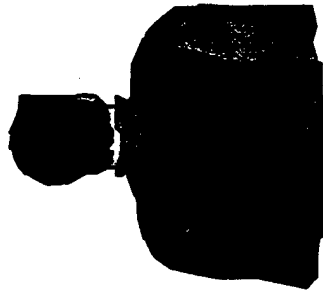

BACKPACK SUSPENSION AND PADDING  
0.5 - 5W



CHEST OR TORSO EXPANSION FROM  
BREATHING OR ROUTINE MOVEMENT  
0.1-1W

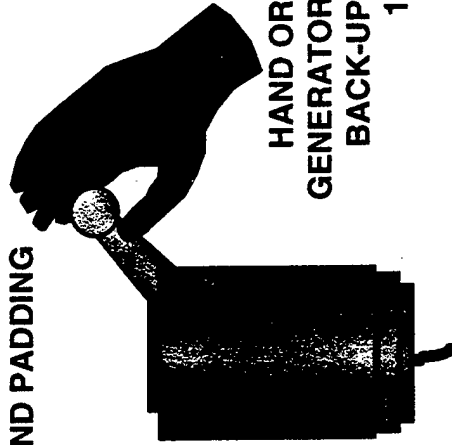

HAND OR LEG CRANKED  
GENERATOR FOR EMERGENCY  
BACK-UP (SHORT-TERM)  
10-100W

# Principal of Operation

---

- Energy is generated due to a change in the capacitance as the film is stretched
  - $E = \frac{1}{2} Q_0^2 (1/C_f - 1/C_i)$
  - $C = \epsilon_r \epsilon_0 \times \text{film area/film thickness}$
  - nearly incompressible polymers increase in area and decrease in thickness when stretched

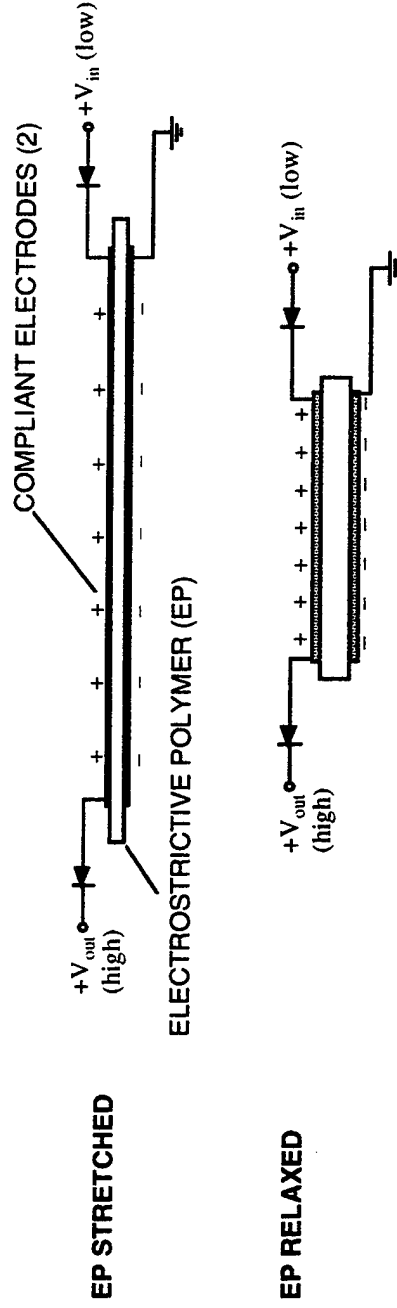

# ***Motivation for Electrostrictive Polymer Energy Conversion***

---

- High energy output per stroke - volumetric and per unit mass
- High energy conversion efficiency - up to 90%
- Materials are soft - allow for large strains typical of human movement
- Flexible design options
  - direct drive - few moving parts, little wear
  - can be configured in almost any shape - easy to incorporate into clothing
  - performance is scale invariant - microscopic to macroscopic sizes
- Rapid response - DC to ultrasonic
- Rugged and reliable - already demonstrated >5 million cycles (and still counting) as an actuator
- Good environmental tolerance - silicone and polyurethane materials already in widespread usage in clothing and footwear
- low cost - inexpensive materials and simple manufacturing techniques
- Smart materials - transducer material can be incorporated into a structural or protective component and can also be used as capacitive or resistive strain sensor for personal monitoring

# Possible Transducer Configurations

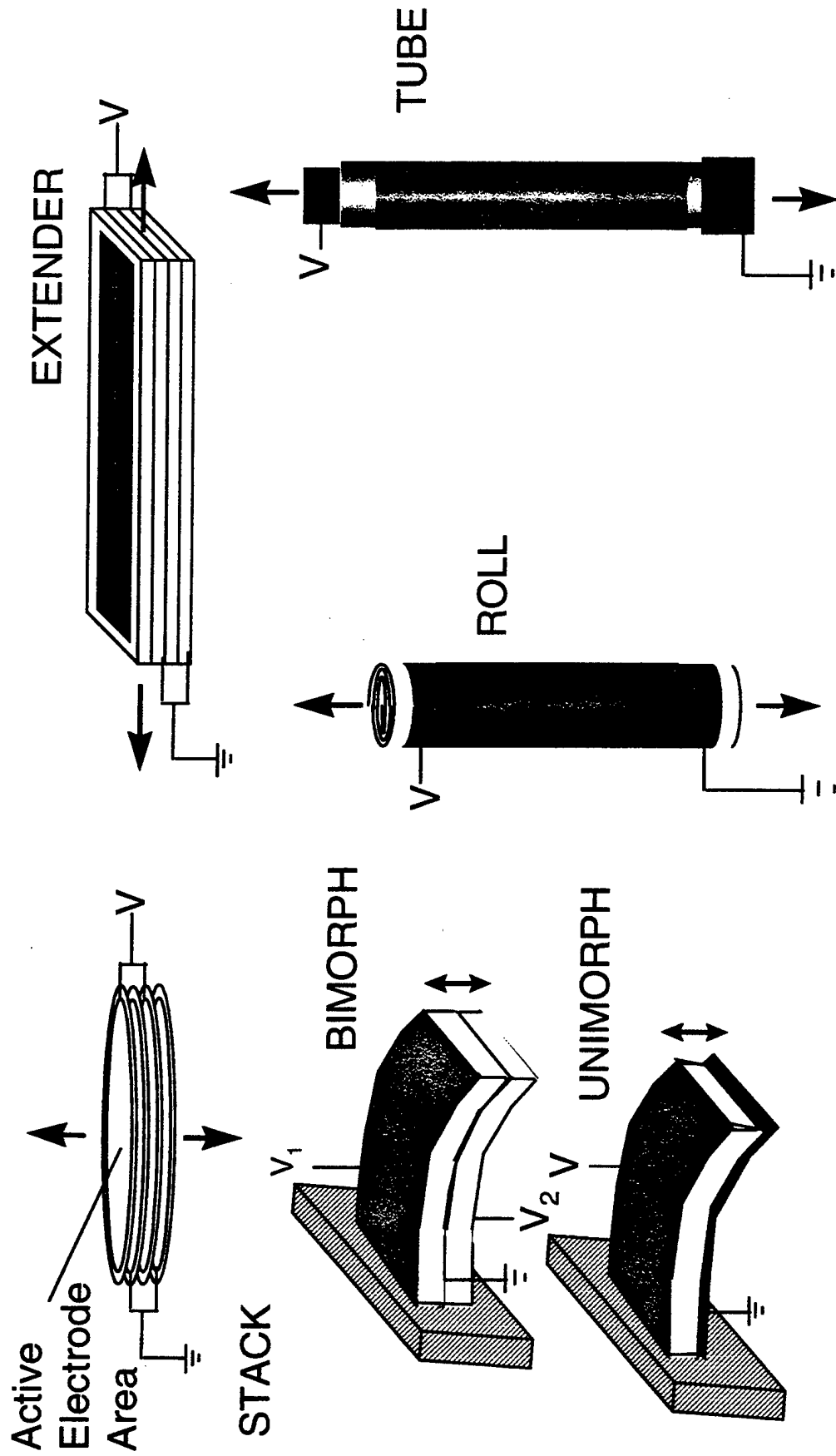

SRI International

# Transducer Technology Comparison

Transducer Type (Specific Example)	Max Strain (%)	Max Energy Density (J/cm <sup>3</sup> )	Specific Density	Max Coupling efficiency k <sup>2</sup> (%)	Conversion Efficiency (%)
Electrostrictive Polymer Artificial Muscle (Silicone) (Polyurethane)	>100 >50	0.7 1.1	1 1.1	90 40	90 80
Electrostatic devices (Integrated Force Array, MCNC)	>100	0.005	~0.7	>90	>90
Electromagnetic (voice coil)	100	0.025	8	>90	>90
Piezoelectric Ceramic (PZT) Polymer (PVDF)	0.2 4	0.035 0.21	7.5 1.8	50 1.4	>90 90

\* Based on an array of 0.01 m thick voice coils, 50% conductor, 50% permanent magnet, 1 T magnetic field, resistivity of 2 ohm-cm, 40,000 W/m<sup>2</sup> power dissipation

# Measured Performance of Various Polymers as Actuators

POLYMER (Specific type)	Energy Density (J/cm <sup>3</sup> )	Strain (%)	Pressure (MPa)	Young's Modulus (MPa)
POLYURETHANE Deerfield PT6100S	0.10	11	1.9	17
SILICONE Dow Corning Sylgard 182	0.034	32	0.21	0.7
FLUOROSILICONE Dow Corning 730	0.019	28	0.070	0.5
FLUOROELASTOMER Lauren L143HC	0.0080	8	0.20	2.5
POLYBUTADIENE Aldrich PBD	0.011	12	0.19	1.7
ISOPRENE Natural Rubber Latex	0.0052	11	0.094	0.85

- Even greater strains and energy density are possible with these elastomers operated as generators

# Specific Example: Heel-strike Generator

---

- Energy from the heel strike is “free” - it would otherwise be dissipated as heat
- Assume
  - the dynamic footfall force of a 70 kg person is 100 kg (~1000 N)
  - the force is decelerated through a distance of 1 cm
  - the energy conversion efficiency is 50%
  - two steps/sec (both feet)
- Energy converted per step is  $0.5 \times 1000\text{N} \times 0.01 \text{ m} = 5 \text{ J}$
- Power generated (both feet) is 10 W
- Assuming a conservative energy density of 0.2 J/cc, the amount of electrostrictive polymers needed to convert 10 J is about 50 g or 50 cc.
- Electromagnetic or piezoelectric devices would weigh more than 10 times this weight

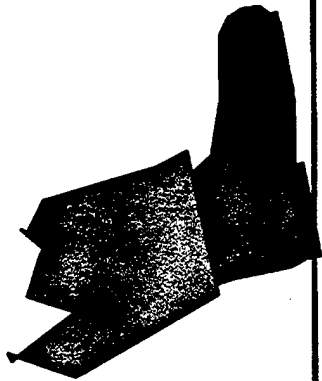

3  
2  
3

# Human-powered Generators

- Large deformation capability of electrostrictive polymers allows for simple and efficient integration into generators  
    efficiency is not speed dependent  
    device can weigh 10x less than an electromagnetic generator  
    with the same output rating
- Novel generator designs with few moving parts are possible
- Similar devices can also be couple to non-human power sources (e.g. engines, wind turbines)

324

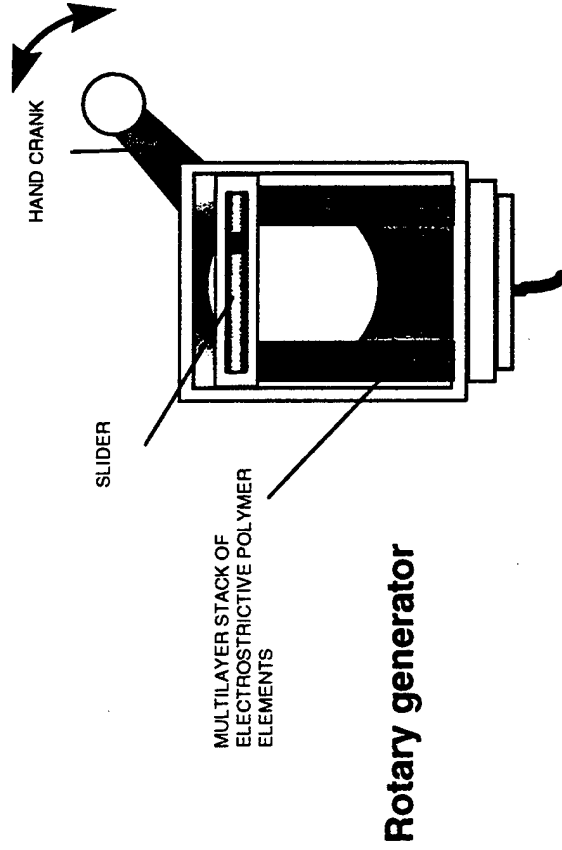

**Rotary generator**

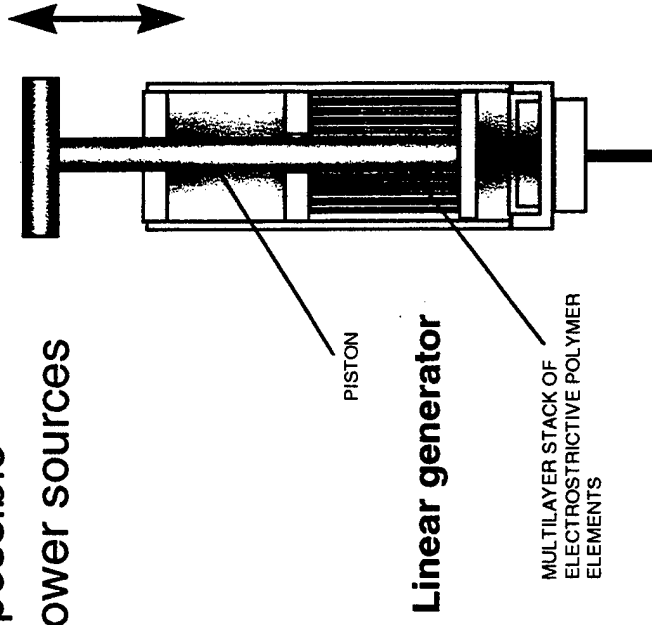

**Linear generator**

# Power Storage and Management

---

- Voltage output will be high voltage time varying
- Short-term and long-term energy storage needed
  - short-term can be high-voltage capacitors
  - long-term will likely require voltage converters to standard batteries
- Circuitry should be “tuned” to the transducer for optimum efficiency
  - highly capacitive load
  - relatively low frequency operation

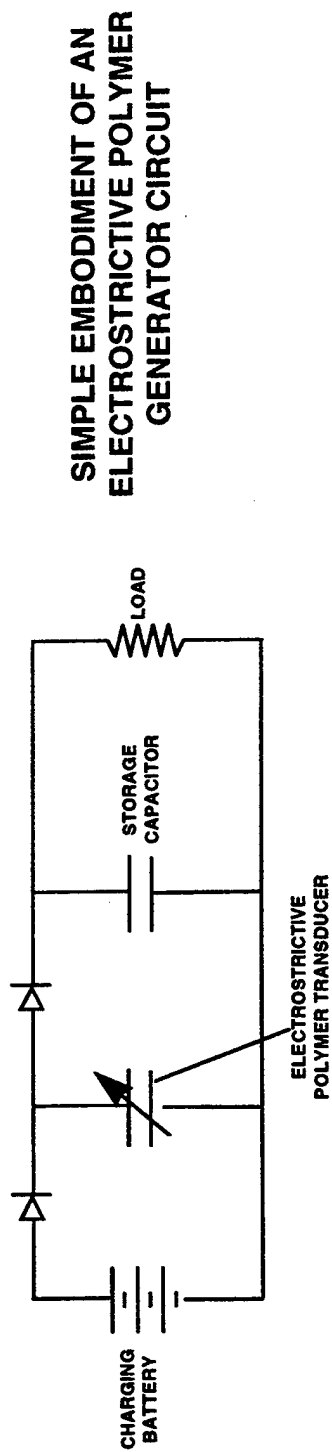

# **Related Power Generator Applications of Electrostrictive Polymers**

- Combustion engines
- Energy scavenging or harvesting from the environment, e.g.:
  - waves
  - wind
  - passing vehicles or foot traffic
  - opening/closing doors

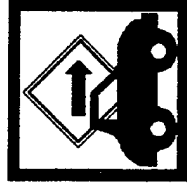
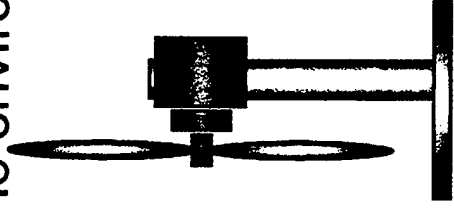
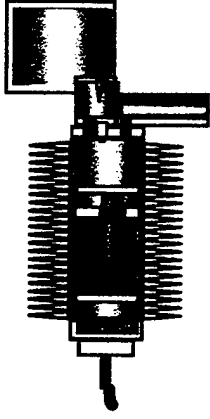

# ***Conclusions and Directions for Research***

---

- Electrostrictive Polymers have unique properties that make them well-suited for devices that convert human motion into electric power, e.g.:
  - high energy density
  - high efficiency
  - good impedance match - large strain capability with low to moderate forces
  - can be fabricated into a variety of configurations
- Electrostrictive polymers have already been used in actuators for a variety of applications
- Application of electrostrictive polymer technology to power generation requires
  - fabrication and testing of rugged and reliable transducer elements
  - design of devices to efficiently utilize human motion (e.g. heel-strike generator)
  - development of circuitry to efficiently utilize generated power

# Electrostrictive Polymer Artificial Muscle

## Applications: Projects and Potential

---



DARPA project investigating electrostrictive polymers for sonar actuators



MITI (Japan) Micromachine Center project is investigating electrostrictive polymer artificial muscle for small robots for pipe inspection



Many other applications and devices being investigated including:  
pumps and valves  
flapping wings and airflow control



ONR sponsored development of improved actuators for robotics



DARPA sponsored development of a MEMS noise suppressor using an electrostrictive polymer loudspeaker

---

SPI International

# ***Applications of Electrostrictive Polymer Artificial Muscle Actuators to Robots***

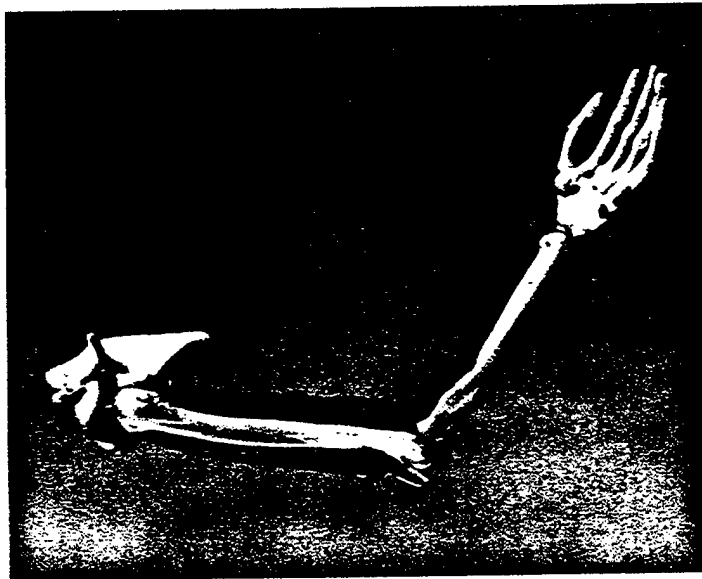

**ROLLED ACTUATORS ACT  
ANTAGONISTICALLY TO MOVE A  
SCALE MODEL OF A HUMAN ARM**



**BIMORPH ACTUATOR  
CAN FUNCTION AS AN  
INSECT-LIKE LEG OR  
WING**



**"LUNAR/MARS SPACE SUIT REQUIREMENTS"**

**Mr. Anthony P. Wagner**

**NASA Johnson Space Center  
Houston, TX 77058**



<b>Lunar / Martian Spacesuit Requirements</b>	<b>CREW AND THERMAL SYSTEMS DIVISION</b>	
	<b>Anthony P. Wagner</b>	<b>Nov. 3, 1997</b>

# Lunar / Martian Spacesuit Requirements

**Anthony P. Wagner**  
**NASA Johnson Space Center**  
**Status as of 11/3/97**





<b>Lunar / Martian Spacesuit Requirements</b>	<b>CREW AND THERMAL SYSTEMS DIVISION</b>
Anthony P. Wagner	Nov. 3, 1997

## Mars EVA Design Reference Mission

- **Driven by Science Exploration**
  - Geology (most mobility demanding)
  - Core Sample Drilling
  - Instrumentation Set-up
- **Physical Infrastructure Interactions as needed beyond robot capability**
  - Construction
  - Repairs
  - ISRU Plant / Drill operation
- **Human Health**
  - Exercise
  - Mental Hygiene



# EVA Advanced Research and Development Road Map



## EARTH

Gravity 1 g

Temperature -50° C to 85° C  
with seasonal variation

Atmospheric Pressure O<sub>2</sub> / N<sub>2</sub> at 1.0 ATM

Day Length 24 hr.

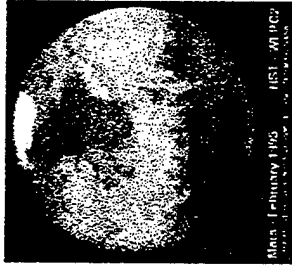

## MARS

0.379 g

-143° C to 17° C  
with seasonal variation

CO<sub>2</sub> at 0.006 ATM

24.6 hr

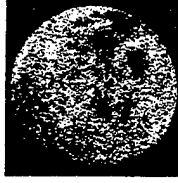

## MOON

0.167 g

-178° C to 127° C

Vacuum

672 hr (28 day)



<b>Lunar / Martian Spacesuit Requirements</b>	<b>CREW AND THERMAL SYSTEMS DIVISION</b>
	<b>Anthony P. Wagner</b>
	<b>Nov. 3, 1997</b>

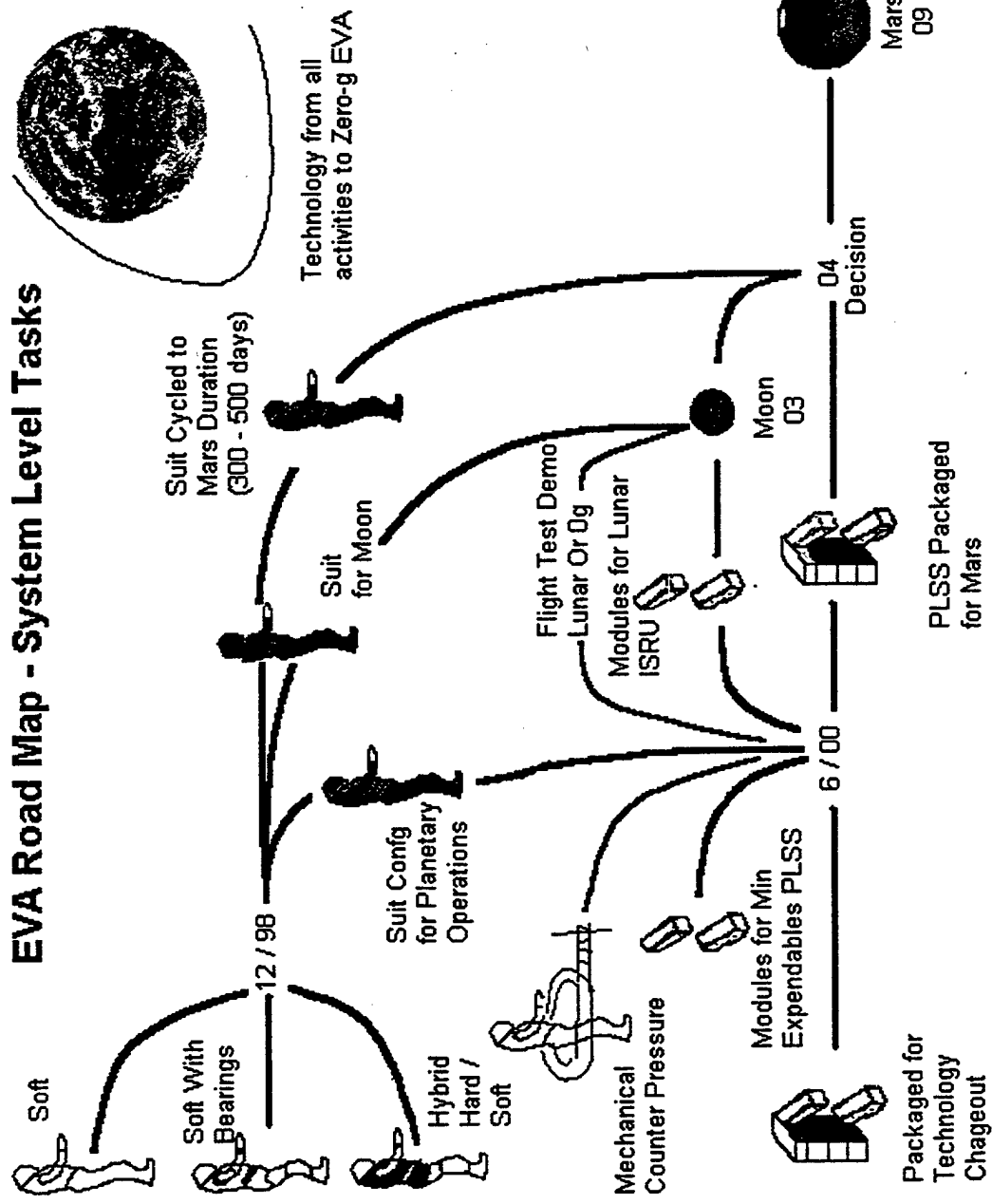



<b>Lunar / Martian Spacesuit Requirements</b>	<b>CREW AND THERMAL SYSTEMS DIVISION</b> <b>Anthony P. Wagner</b> <b>Nov. 3, 1997</b>
---	--

## Mars EVA Design Reference Mission

- **Operational Environment**
  - Six person crew with normal day consisting of two (2 person) teams EVA
  - 3 or 4 persons in rover for up to 10 days at a time
  - Light work and health EVA's by single persons are planned with biomed and location feedback constantly to base
  - Radiation storm protection provided by the Base or Pressurized Rover
  - Protection from large predictable storms (Macro Storms) provided by Base or Pressurized Rover
  - Protection from small unpredictable micro storms provided by suit





<b>Lunar / Martian Spacesuit Requirements</b>	<b>CREW AND THERMAL SYSTEMS DIVISION</b> <b>Anthony P. Wagner</b> <b>Nov. 3, 1997</b>
---	--

- **Space Suit System**
  - Design for Mars, Accommodate Moon, Technology Transfer for Zero g
  - Optimized for Surface Operations but Capable of
    - Zero g for transit contingencies
    - Mars Launch and Earth Entry Cabin Backup
  - Geology as Design Reference for Mobility
  - Reconfigurable Gloves (Mittens) to Meet Dexterity Needs
  - Removable, Cleanable Outer Garments for Dust / Thermal Protection
  - One Size Fits All Sizing with Minimum Overhead to Expand Commonality
  - Integral Emergency Backup System
  - Use the Natural Environment As Much As Possible
    - No Venting Constraints
    - Radiate / Conject for Heat Rejection





<b>Lunar / Martian Spacesuit Requirements</b>	<b>CREW AND THERMAL SYSTEMS DIVISION</b>
Anthony P. Wagner	Nov. 3, 1997

- **Space Suit System**
  - 3.7 psi Suit - No prebreathe impact
  - Flexible EVA time (4 or 8 hours) by modular expendables
  - Biomedical Instrumentation Communicated to Base and Self
  - Rich information available to EVA crewperson
    - Database from Base
    - Sensors (low light; binoculars; IR)
    - Continuous Navigation Aides
  - Rich Communications available between crew and to base
    - Voice & TV
  - First aid/evacuation provisions included "on back"
  - Allows "Overnight Camping" in Contingency Situations
  - Launch/Entry in EVA suit





<b>Lunar / Martian Spacesuit Requirements</b>	<b>CREW AND THERMAL SYSTEMS DIVISION</b>
	Anthony P. Wagner Nov. 3, 1997

- **Space Suit System**
  - Lightweight
    - PLSS < 40 Kg (85 lbm)
    - Suit < 30 Kg (60 lbm)
  - Low Volume
    - 8-hour PLSS volume 70% of STS EMU PLSS
  - Robust
    - Allow Fall on Sharp Rocks Without Danger Induced By Suit
    - Operation Unaffected by Dust and Dirt
  - Suit Comfortable Enough for Contingency Camp Out
    - Sleeping
    - Eating
    - Liquid and solid waste collection
  - Display and Controls to
    - Biomedical Display to Crewperson in Suit
    - Automatic Thermal Control with Manual Set Point Adjust
    - Integrated IR & UV visual view reproduction for day/night





<b>Lunar / Martian Spacesuit Requirements</b>	<b>CREW AND THERMAL SYSTEMS DIVISION</b>
Anthony P. Wagner	Nov. 3, 1997



- **Space Suit System**
  - PLSS with
  - PPCO2 less than or equal to Mars atmosphere
    - 6mmHg (Mars Atmosphere) for nominal exercise
    - 10 mmHg for exercise peak
  - Thermal control w/o launch mass expendables
  - Humidity - Never saturated, no fogging, sufficient to prevent sparking
  - Sensor & Communications Minimum Volume and Integrated
    - Voice recognition > 98% with < 1% missed recognition
  - Communications - Suit Range at the Mars Horizon
  - Minimize Loss of Hydrogen Resource





<b>Lunar / Martian Spacesuit Requirements</b>	<b>CREW AND THERMAL SYSTEMS DIVISION</b>	
	Anthony P. Wagner	Nov. 3, 1997

**Goal is to eliminate majority or all of the mass, volume, and power of cooling loop by using an alternative such as thermoelectrics :**

- Carnot maximum efficiency of cooling loop  $= (90F - -300F) / 90F = 71\%$   
(90F = skin temperature, -300F = Cryogenic oxygen temperature)
- Minimum metabolic rate = 400 BTU/hr = 117 Watts
- Maximum metabolic rate = 2000 BTU/hr = 585 Watts
- Efficiency of thermoelectrics and heat pipe determine output  
(Heat pipe needed to draw heat outside of 100% oxygen environment)
- Could also use substantial spacesuit boot surface for piezoelectric power  
(1/3 g will reduce output power capability)





<b>Lunar / Martian Spacesuit Requirements</b>	<b>CREW AND THERMAL SYSTEMS DIVISION</b>	
	Anthony P. Wagner	Nov. 3, 1997

**Savings through potential elimination of cooling loop :**

- No need for LCVG, comfort heater, pump, accumulator, radiator, plumbing, solenoids, 21 sensors (T, P, I, C, S), water, filters, QD's
- Reduce mass 18 Kg (38 lbm) out of 68 Kg (145 lbm) - goal is 40Kg (85 lbm)
- Reduce volume by 19 %
- Reduce power demand 25 out of 62 Watts - plus generate power during cooling phase if replaced with thermoelectrics



# ADVANCED SUIT PROJECT: PLS ITEM LIST

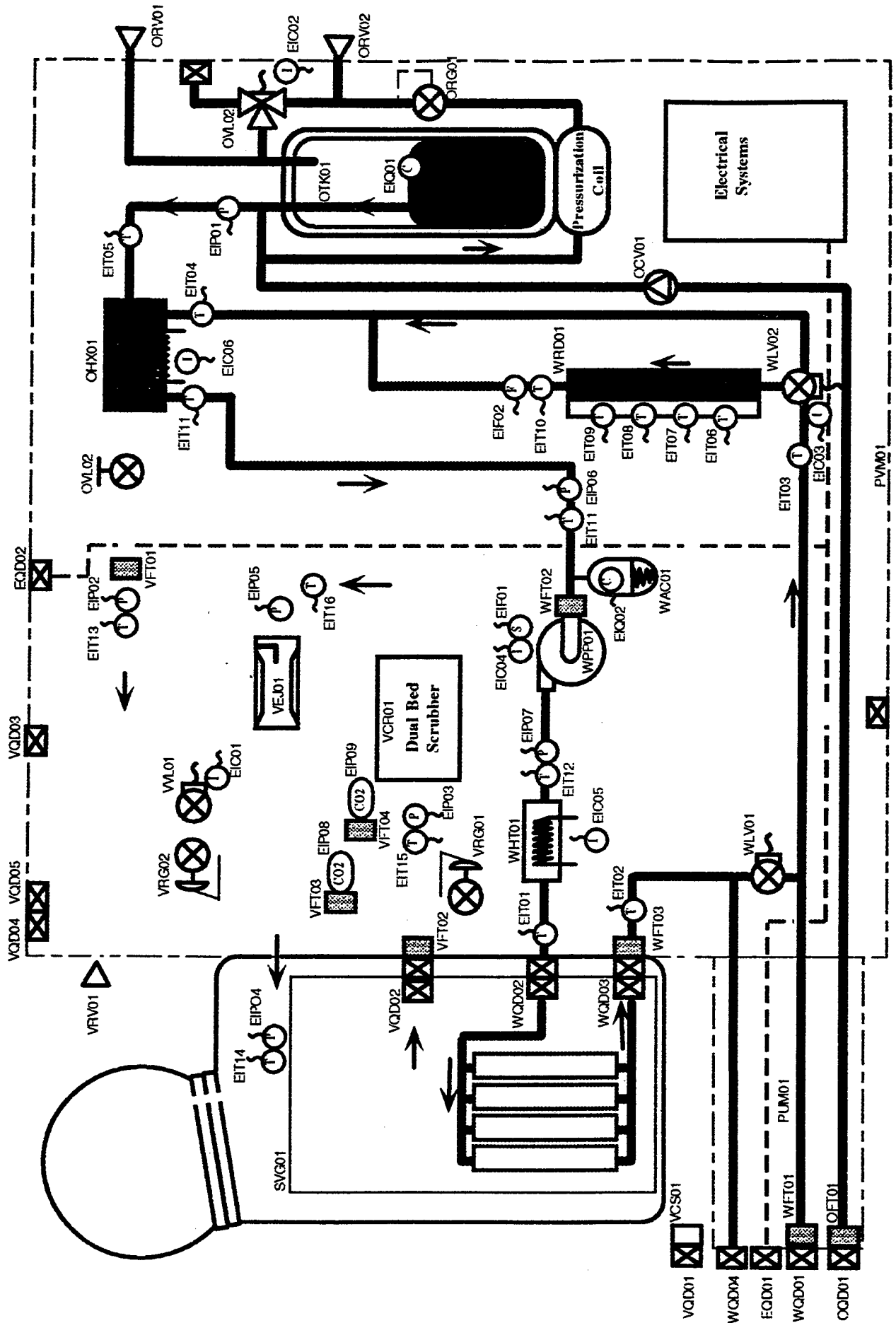

# ADVANCED SUIT PROJECT CPLSS

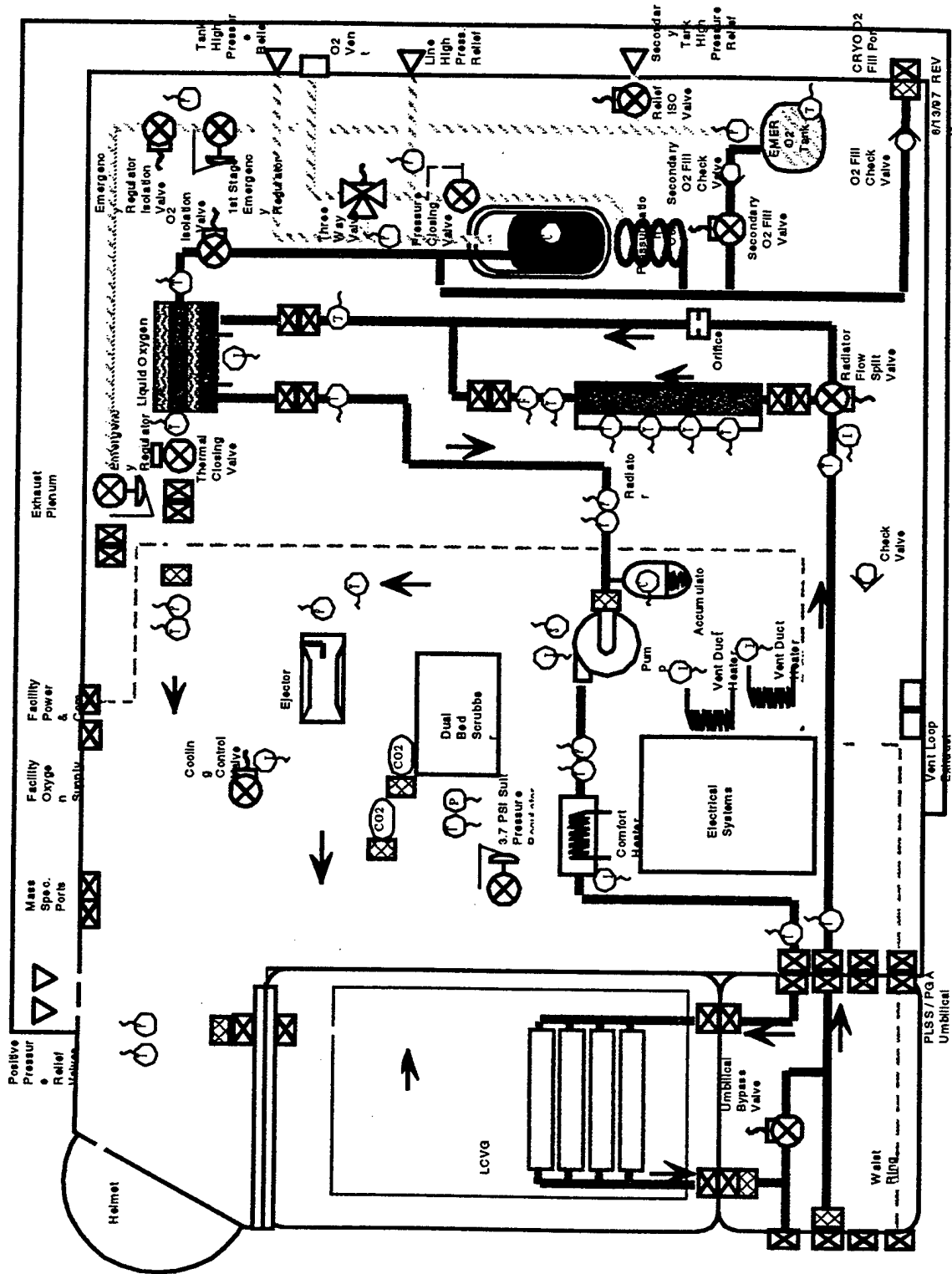

# Advanced Spacesuit Electrical Schematic

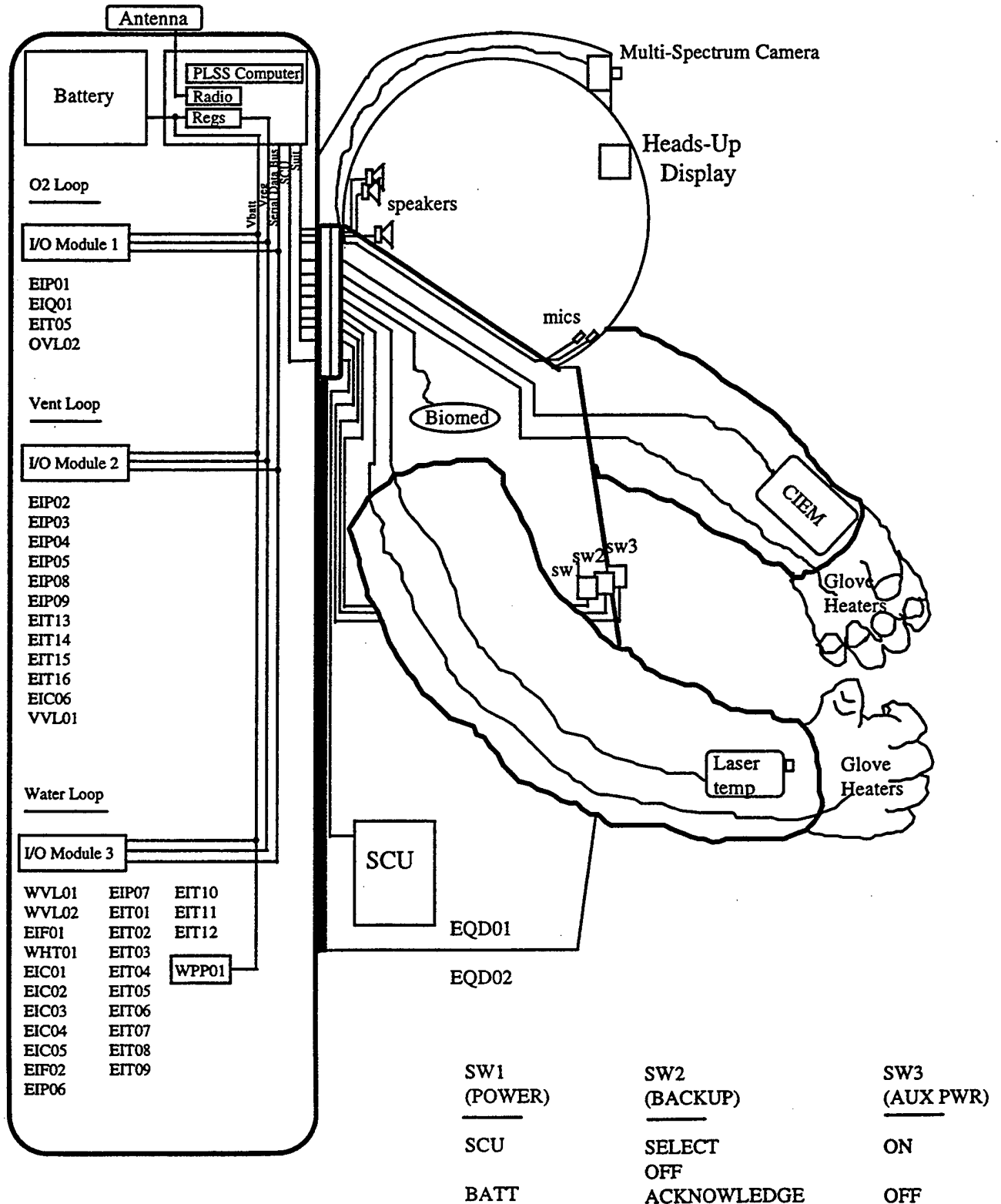



**TECHNOLOGY SESSION 2**

**“INTEGRATED POWER MANAGEMENT FOR  
MICROSYSTEMS”**

**Mr. Dwayne N. Fry**

**Oak Ridge National Laboratory  
Oak Ridge, TN 37831-6009**

## **Integrated Power Management for Microsystems**

Presented at the Prospector IX Workshop  
November 3-5, 1997

Dwayne N. Fry  
Alan L. Wintenberg  
Bill L. Bryan

Instrumentation & Controls Division  
Oak Ridge National Laboratory  
P. O. Box 2008  
Oak Ridge, TN 37831-6009  
Telephone: (423) 574-5565  
e-mail: frydn@ornl.gov

There is a need for a universal power module for microsystems. This module should provide power conditioning, energy storage, and load matching for a variety of energy sources and loads such as microelectromechanical systems (MEMS) and wireless sensors and micro-robots. There are a variety of potential ambient and human powered energy sources, which can supply some of the power needs of the military. The challenge is to capture these available sources of electrical energy and condition them to meet the voltage, current, and overall power demands of field-deployable microelectronics and MEMS-based devices such as wireless sensors and micro-robots. Most natural and man-made energy sources found in the environment have a low specific power and are not generally available on a continuous basis. Likewise, human-based energy sources must be optimally managed to meet the power needs in the field. Therefore, a power supply must have the ability to capture the available energy and store it in such a manner to be useful to meet the mission requirements of the device that is connected to the source. It must continuously monitor the status of energy stored and determine the expected demands of the device. A microelectronics-based power management chip can be developed to meet these objectives.

The major challenge in realizing this concept will be the design of an intelligent power-conditioning chip that consumes a minimum of power to perform the functions of power conditioning, storage, load matching, and status monitoring.

For a versatile chip design that can use a variety of energy sources, it is important to not constrain the energy source characteristics unduly. One suggested approach assumes only that the source is capable of delivering charge to a small capacitive load. This would be true for photovoltaic, piezoelectric, rotary or linear electric generators, thermoelectric and many other sources. As shown in Fig. 1, the resulting source voltages are monitored, and when a sufficient value is present, the power converter will multiply the voltage up to the storage supply voltage

and transfer it to storage. The storage element may be an ultracapacitor or rechargeable battery. Power would be delivered to the load through another switched capacitor circuit. This would allow metering of the power delivered to the load and, if needed, a voltage transformation. The metering function could also be used to help keep track of the amount of energy remaining in the storage element. A reserve energy storage element would be used to maintain power for the intelligent power controller, which is responsible for administering power transfers and for monitoring the demand signal from the load. It is anticipated that the load may require some very low level of power continuously (for a wake-up circuit, for preventing loss of memory, etc.), so an unswitched low-power output is provided. When the demand signal from the load signals a request for significant power, the intelligent power controller replies using the power status signal. If sufficient power is available in the storage element, then the power status signal is true and power is transferred to the load until the demand ceases. Another function of the intelligent power controller is to recharge the reserve energy storage element periodically.

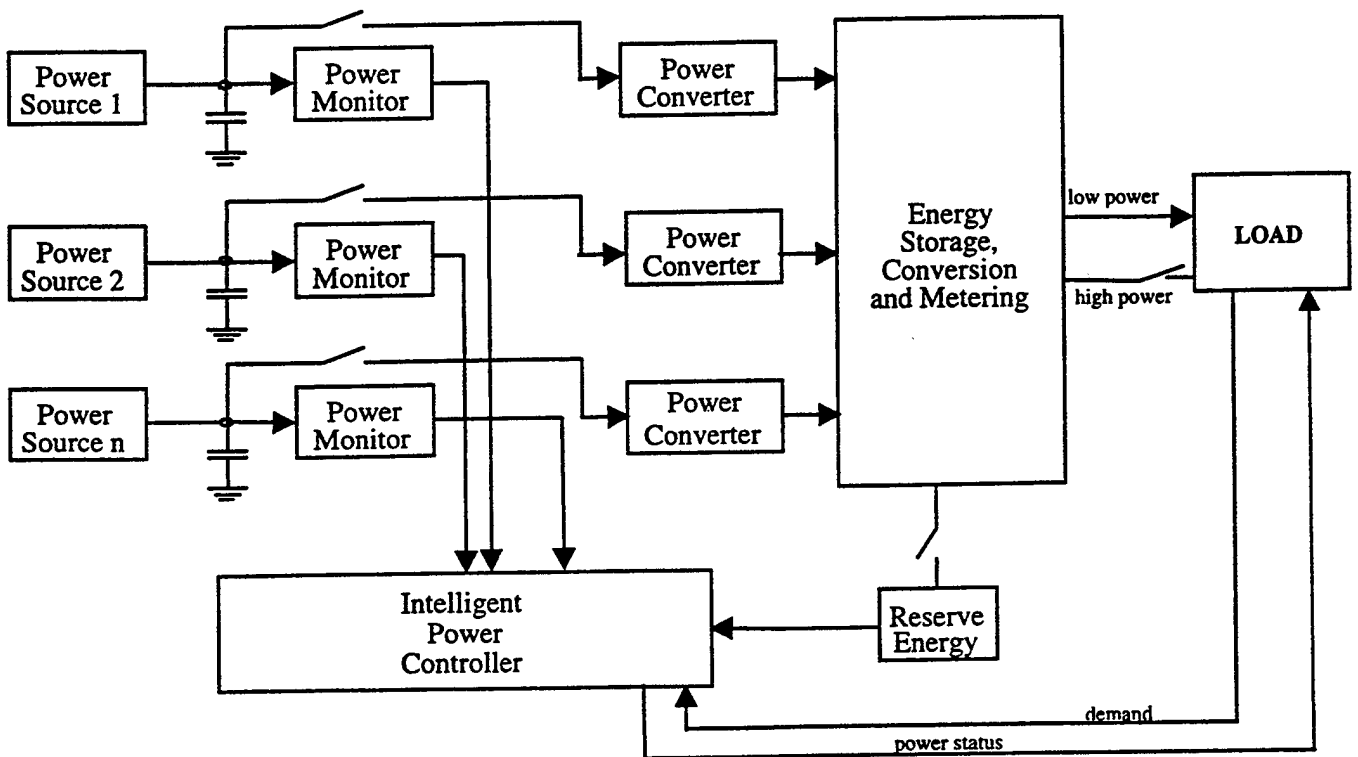

Fig. 1. Concept of power conditioning chip

The power conditioning integrated circuit (IC) would be implemented using CMOS technology. Integrated circuits fabricated using standard CMOS processes offer a number of features well suited to this application: digital circuits that require essentially no static power, low-power analog circuits, and good switches that are necessary for switched capacitor circuits. It should be possible to implement the entire circuit using a single IC with a very limited number of external components (such as capacitors too large to implement on the IC, i.e., those greater than a few tens of pF.) A prototype device would be made using a 1.2 or 0.8 micron process that would allow 5-V operation. This choice should not be restrictive as the same circuit could be converted to other CMOS processes. Processes of 0.5 micron or smaller would allow a greater density of logic for a given die size, but would be limited to 3.3-V operation. To deliver greater voltages to the load, a 3-micron process could be used which would allow approximately 20-V operation, or external components could be added to implement a boost dc-dc converter.

The prototype power conditioning IC would be capable of delivering a peak power of 100 mW at 5 V. The nominal operating condition would be a very low duty cycle for a relatively high power load, and a low-power source available for long periods of time, or a moderate-power source available intermittently. An example would be a wireless sensor and transmitter requiring 100 mW for 10 ms every 10 minutes and a source delivering perhaps five microwatts continuously. However, the device should also be capable of delivering approximately 100 mW continuously if sufficient power is available from the sources. Scaling for higher power outputs would be addressed by including features that would allow using multiple devices in parallel, or by resizing power sections of the IC to allow greater power input and output levels.

---

---

# Integrated Power Management for Microsystems

**Dwayne N. Fry**

**Alan L. Wintenberg**

**Bill L. Bryan**

Instrumentation & Controls Division

Oak Ridge National Laboratory

423-574-5565

e-mail: [frydn@ornl.gov](mailto:frydn@ornl.gov)

Presented at the Prospector IX Workshop

November 3-5, 1997

**I&C**

**ornl**

# Universal Power Module Will Condition a Variety of Energy Sources and Match to a Variety of Loads

---

---

- Most energy sources do not naturally produce suitable power for the load, i.e.. proper voltage level
- Most human powered energy sources are intermittent and have a low specific power
- A number of loads such as wireless sensors and transmitters require power on an intermittent basis
- Intelligent power module will capture energy, store, condition the energy to proper voltage, and deliver to load on demand



# Concept of An Integrated Intelligent Micropower Supply

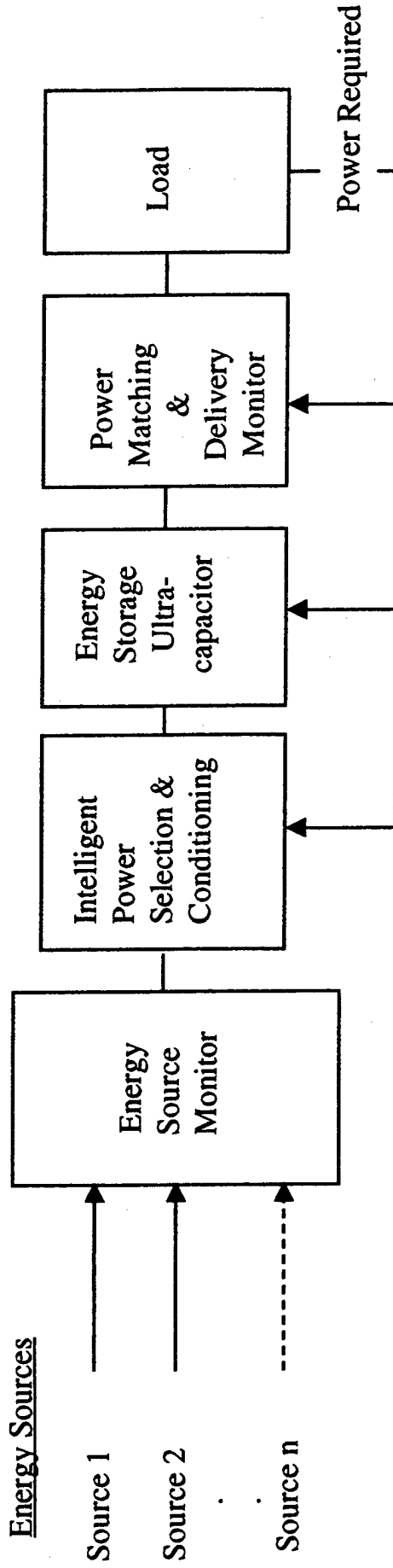

# Concept of Power Conditioning Chip

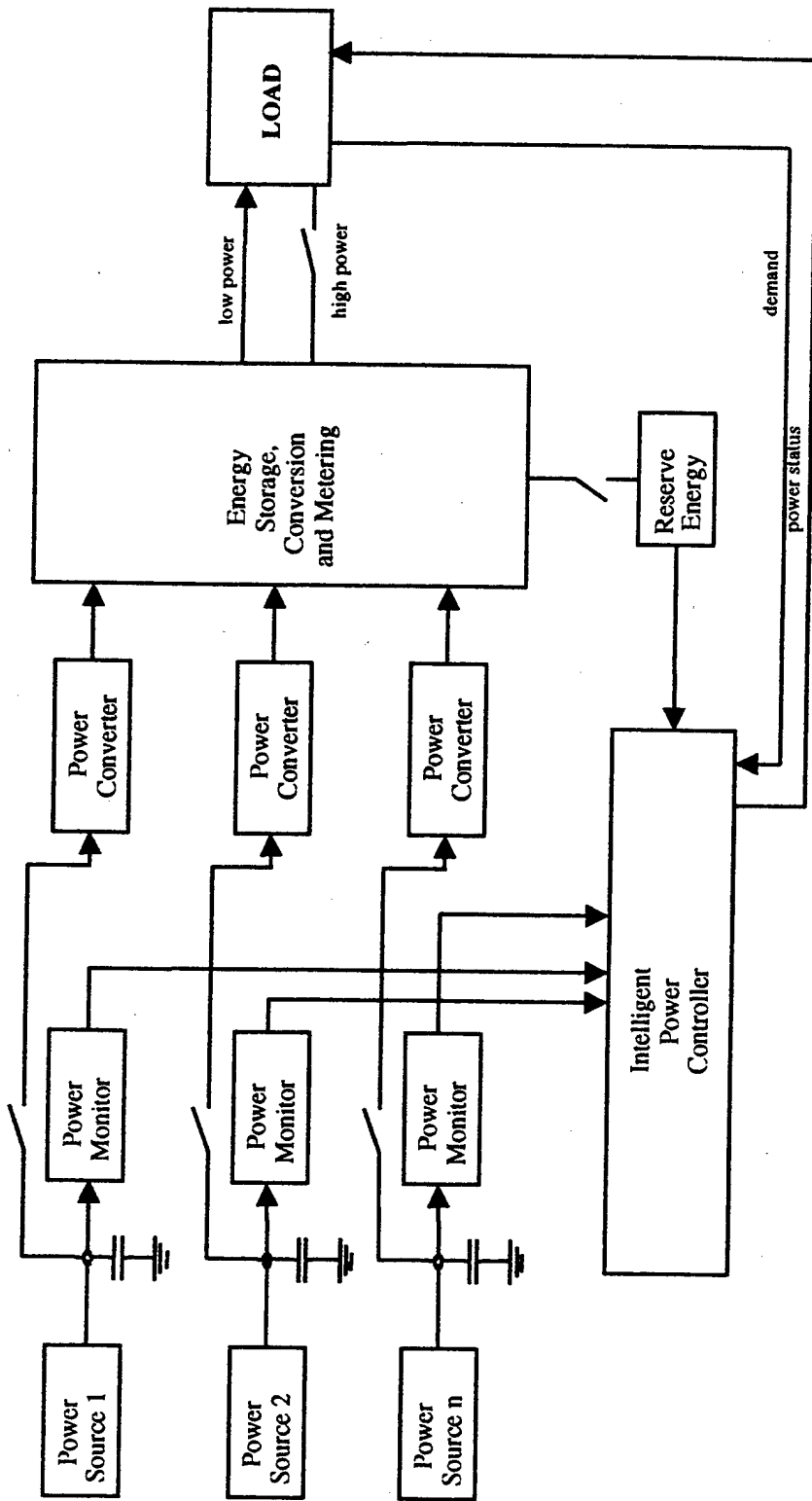

# The Universal Module Performs Several Functions

---

---

- Power monitor determines status of charge collected from energy source
- Power converter converts charge to voltage for storage
- Storage medium also matches to load requirements and keeps track of available stored energy
- Intelligent controller administers power transfer to load and monitors demand signal from load
- Reserve energy supplies power to intelligent controller

# The Power Module Could be Implemented on a Chip Using CMOS Technology

---

---

- CMOS digital logic circuit requires essentially no static power
- Capability of low-power analog circuits
- Provides good switches
- Five volt operation possible with 1.2 or 0.8 micron process
- Twenty volts with 3 micron process
- Peak power delivery approximately 100mW at 5 V
- The concept should be scaleable depending on load power requirements

I&C

**ornl**





# Our First Fully Integrated Wireless Data-Acquisition Chip

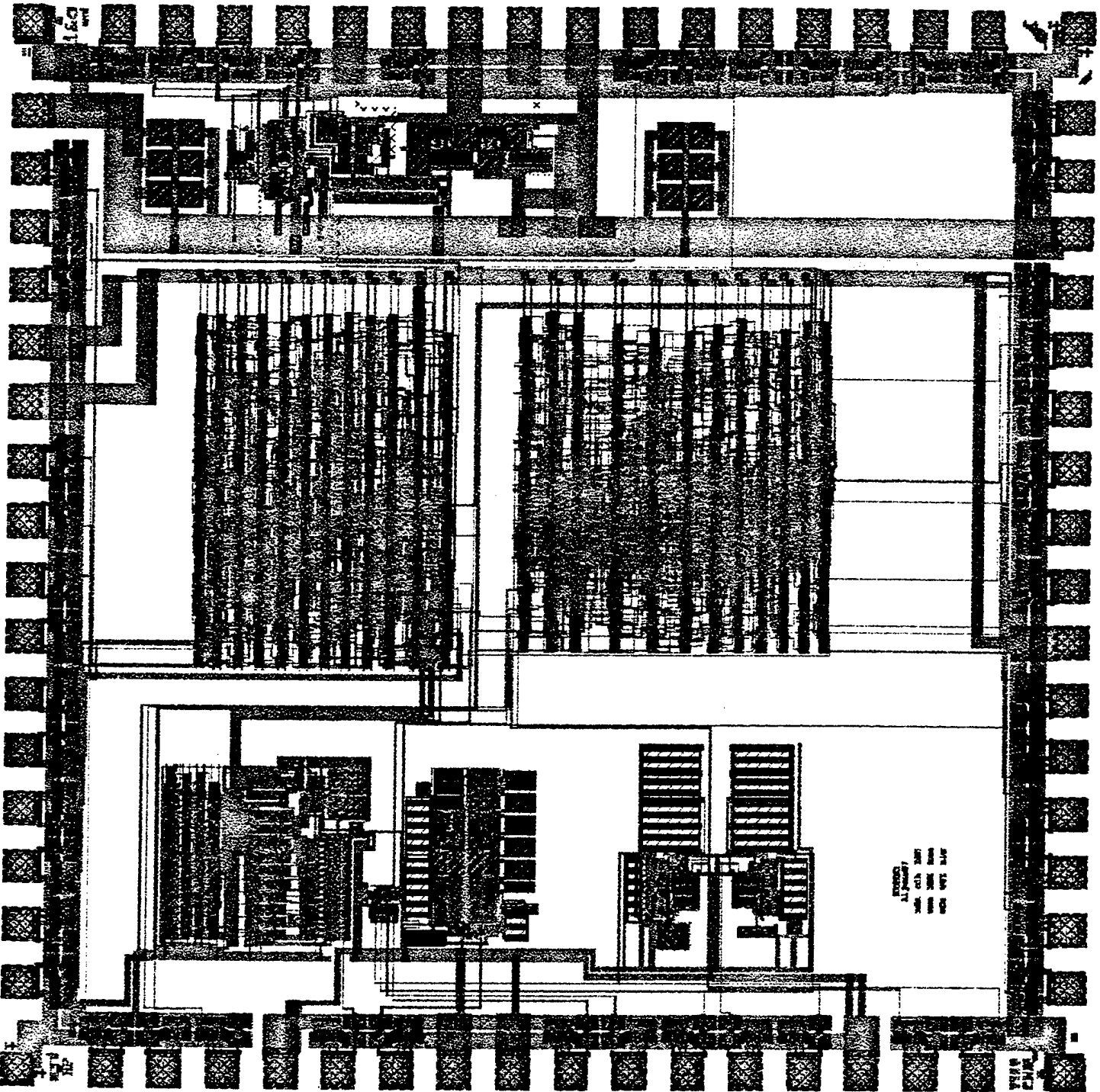

- Two Thermometers
- Two Uncommitted Inputs
- 10-bit ADC
- Control Logic
- Spread-spectrum Radio-frequency Transmitter

# **“SEIKO HUMAN POWERED QUARTZ WATCH”**

## **OVERVIEW**

**Mr. Masakatsu Saka**

**Epson Research and Development Inc.  
San Jose, CA 95134**

## **DETAILS OF THE DEVICE**

**Mr. Kinya Matsuzawa**

**Seiko Epson Corporation  
Nagano-ken, 392 Japan**

## **APPLICATIONS OF AGS**

**Mr. Kinya Matsuzawa**

**Seiko Epson Corporation  
Nagano-ken, 392 Japan**

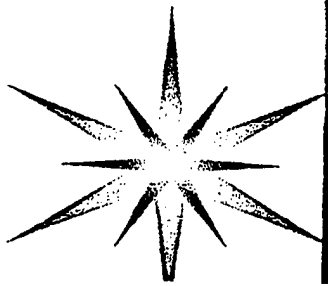

# **Kinetic Generator System**



**Epson Research & Development Inc.**

**Masakatsu Saka**

**Seiko-Epson Corp.**

**Kinya Matsuzawa**



Auto generating system

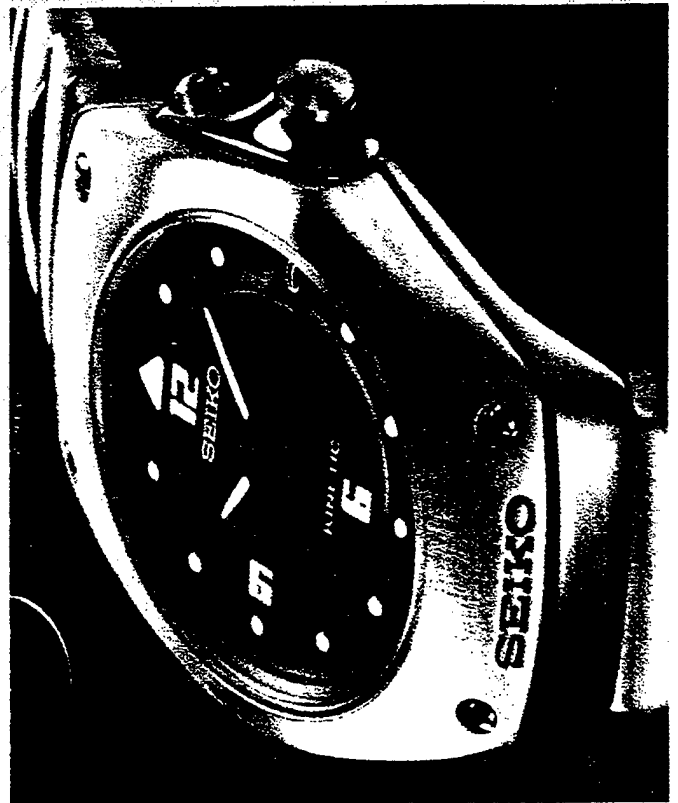
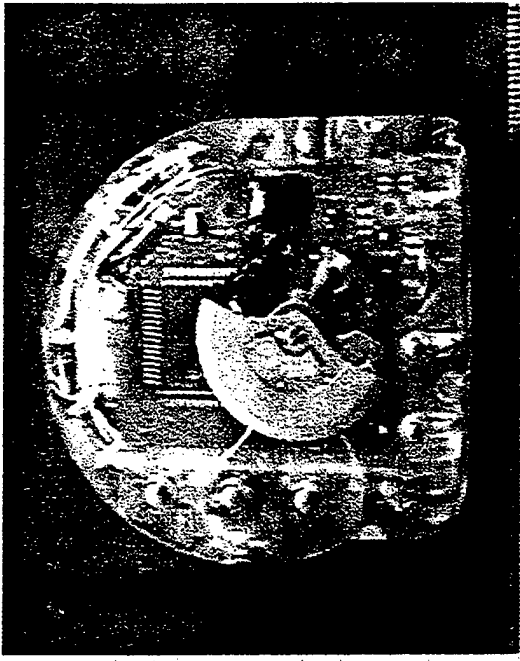

KINETIC

SEIKO EPSON CORPORATION

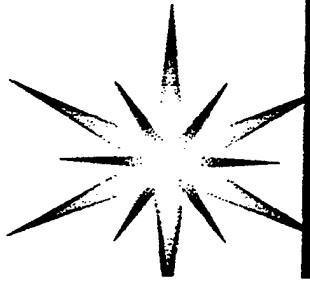

# **Seiko's Automatic Generating System (AGS)**

---

---

- **Background of Seiko watch**
- **Concept of Automatic Generating System**
- **Details of mechanical feature**
- **Details of electrical circuitry**
- **Further application of AGS**



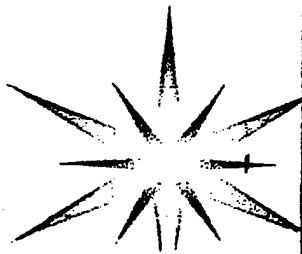

# Background of Seiko watch

---

---

- > 1969 The first quartz watch in the world
- > 1972 Mass production of quartz watch
- > 1974 The first liquid crystal digital watch in the world
- > 1981 The first liquid crystal TV in the world  
(watch type)
- > 1985 The first liquid crystal color TV in the world  
(palm top type)
- > 1988 The first kinetic energy watch in the world  
(AGS)

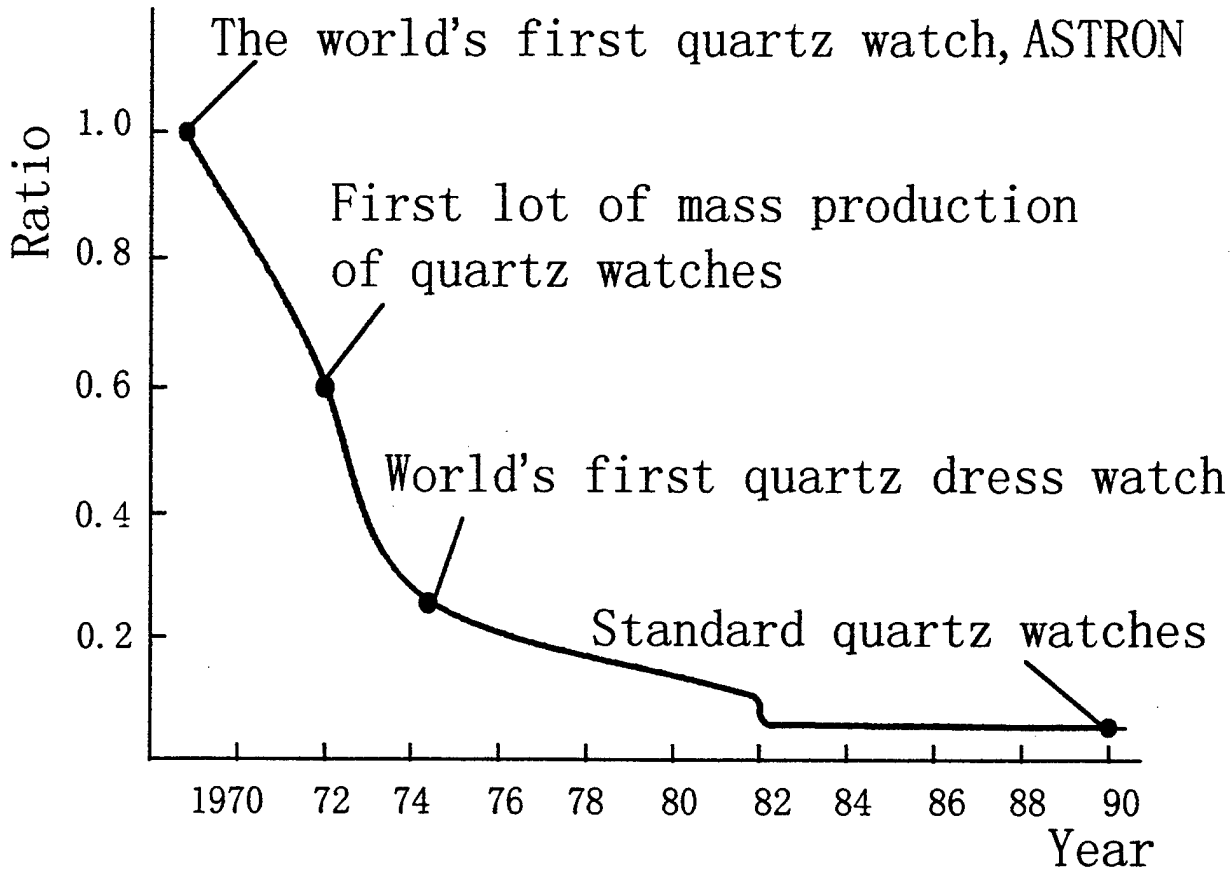

## Trend in electrical current consumption (Seiko Epson data)

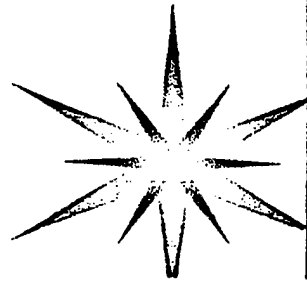

## Concept of AGS

---

---

- > Rotating an oscillating weight through moving an arm
- > Accelerating rotation by gear train and transferred to a magnetic rotor
- > Generating induced voltage in a coil by high speed rotation of a rotor through a stator
- > Rectifying induced current and Storing it in a source

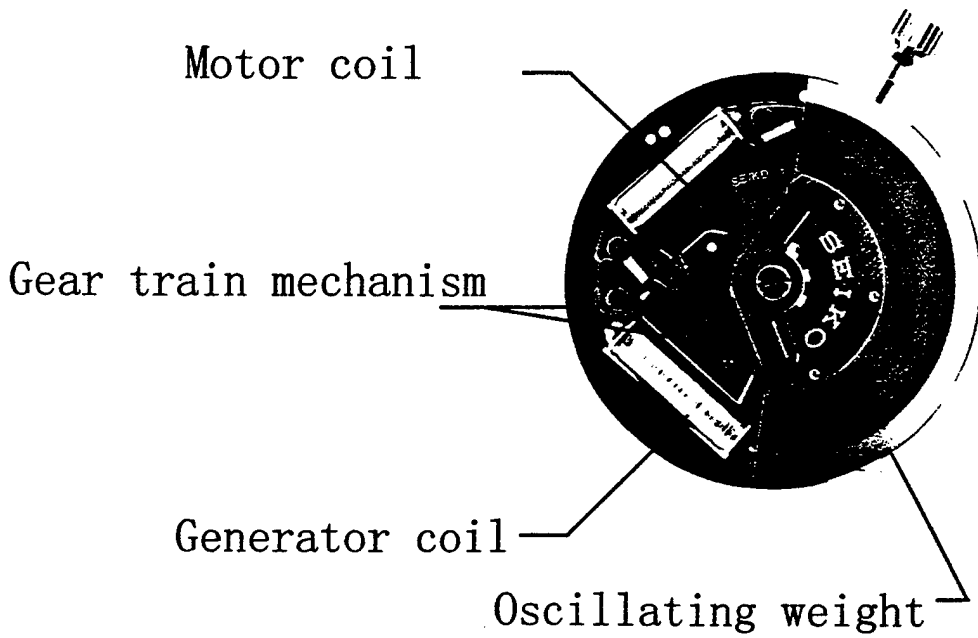
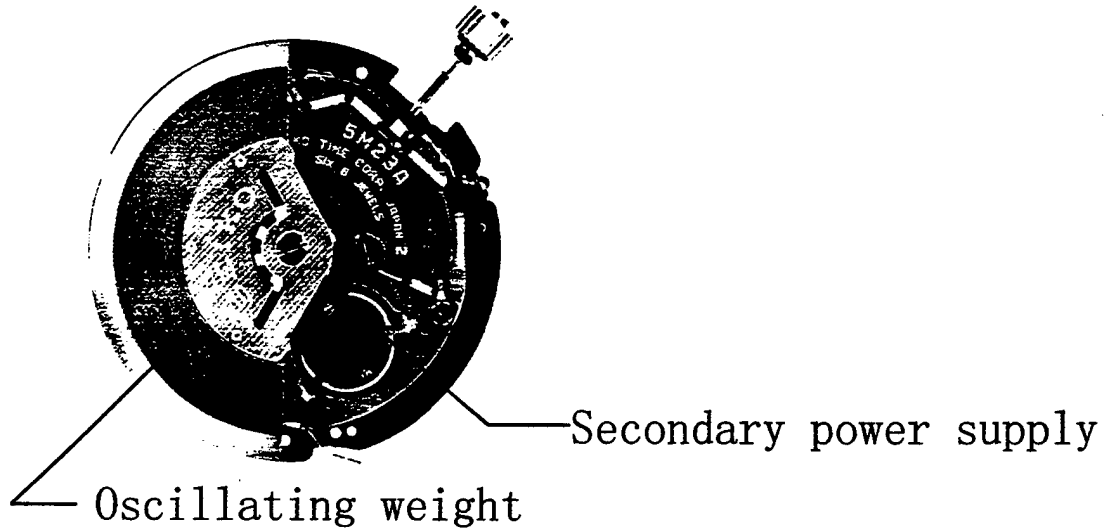

## AGS appearance

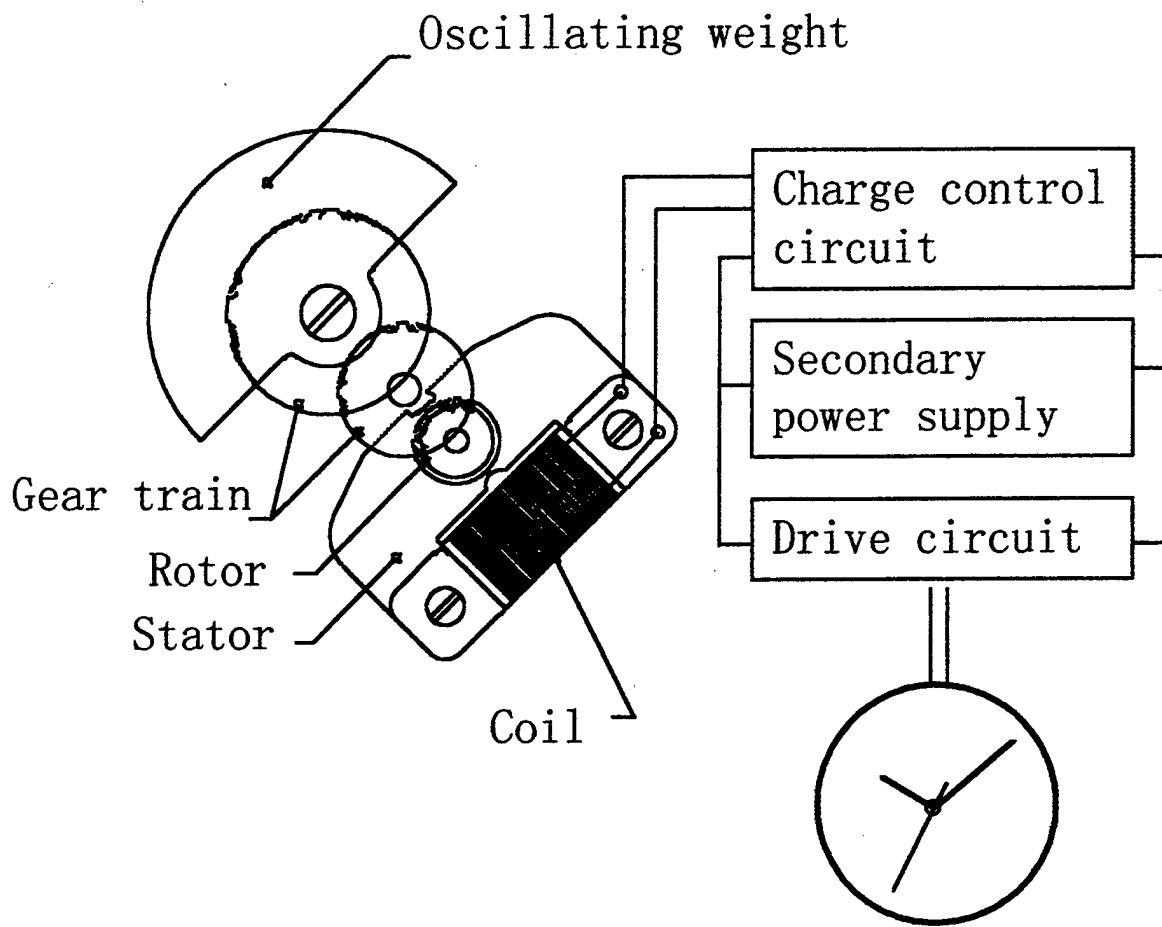

**AGS outline diagram**

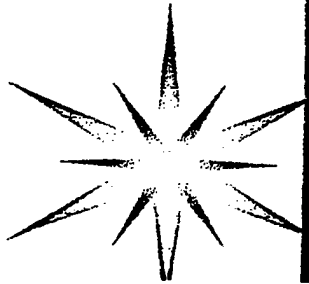

# The feature of Seiko's AGS

---

---

- Consistency and stability of generation power from random movement of an oscillating weight ( Frequent change of very slow motion and high speed motion)
- Very slow motion-100 times accelerated rotation through gear trains
  - High speed motion-Shock absorption mechanism
- Constant power supply even if induced voltage lowered
  - a second power supply circuitry for raising induced voltage

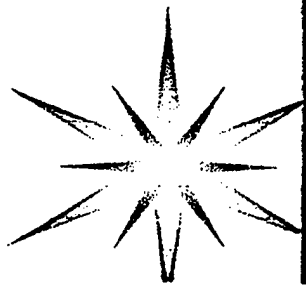

## Further application of AGS

---

---

- **Ecological research**
  - A transmitter for tracking behavior of migratory animals (a whale, a dolphin, a migratory bird) and sending data of them to a station via satellite.
  - Need of constant power generation for a transmitter during long time(1-2yrs)

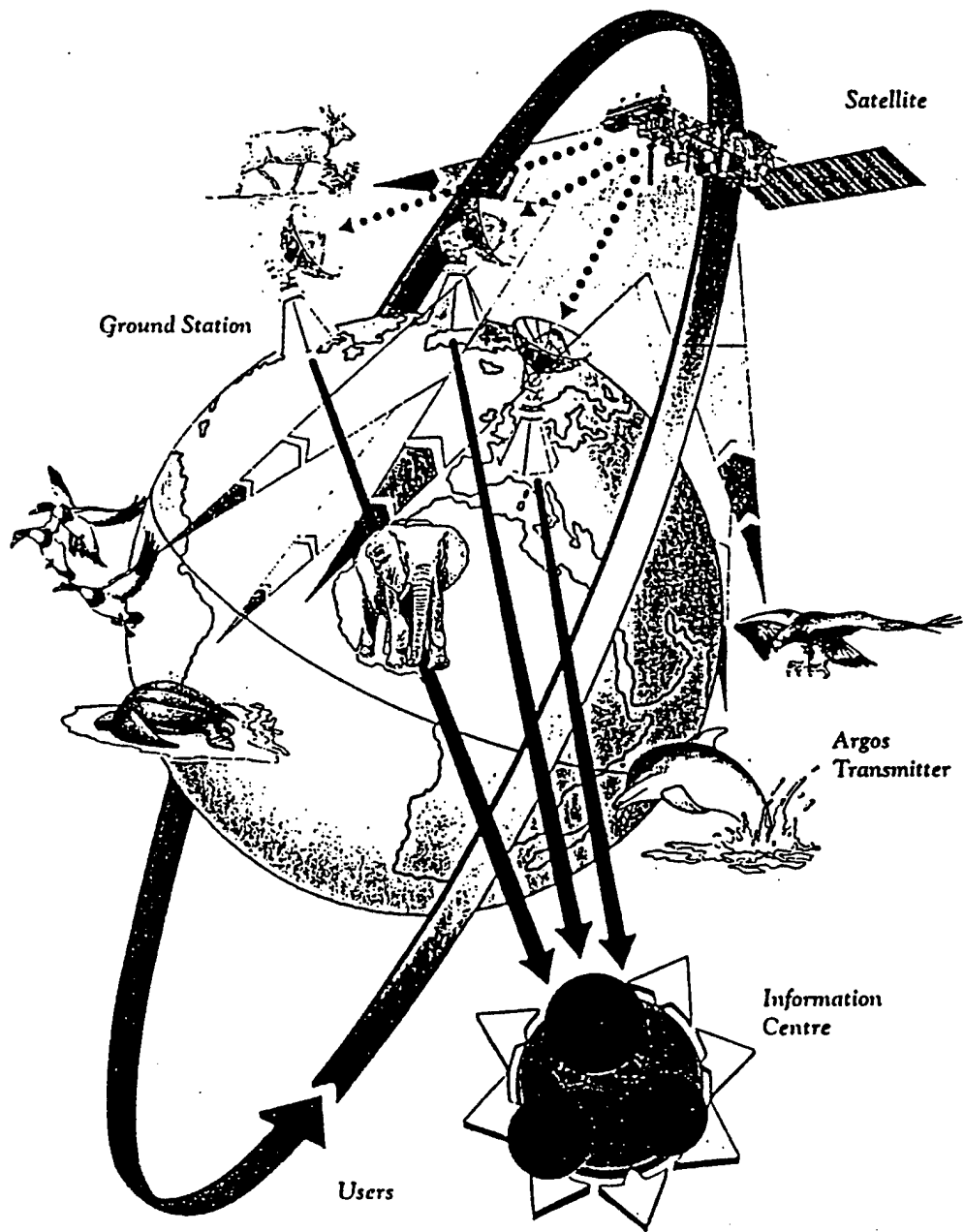

# Auto generating system

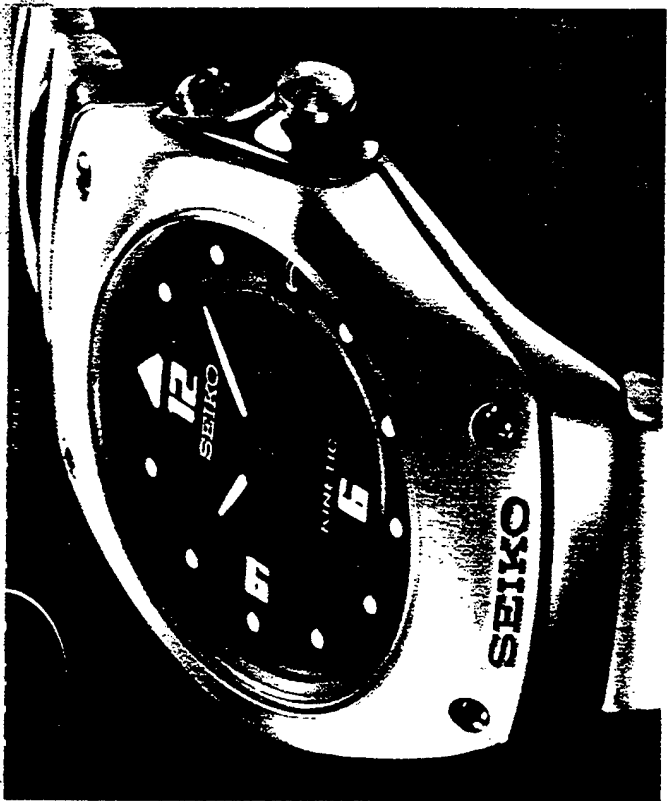
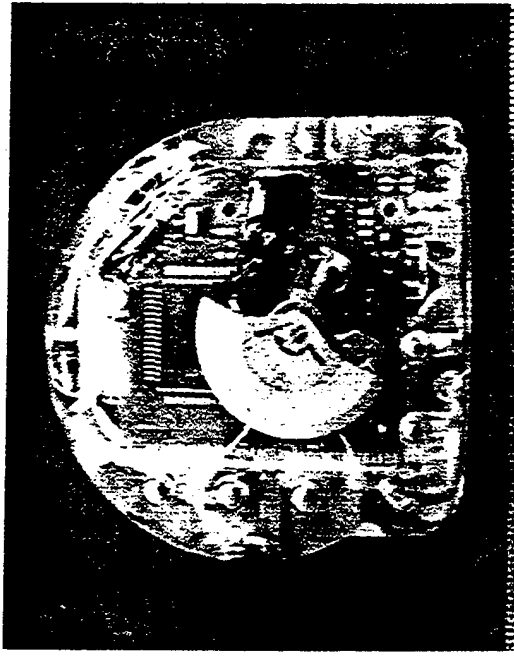

**KINETIC**

SEIKO CORPORATION

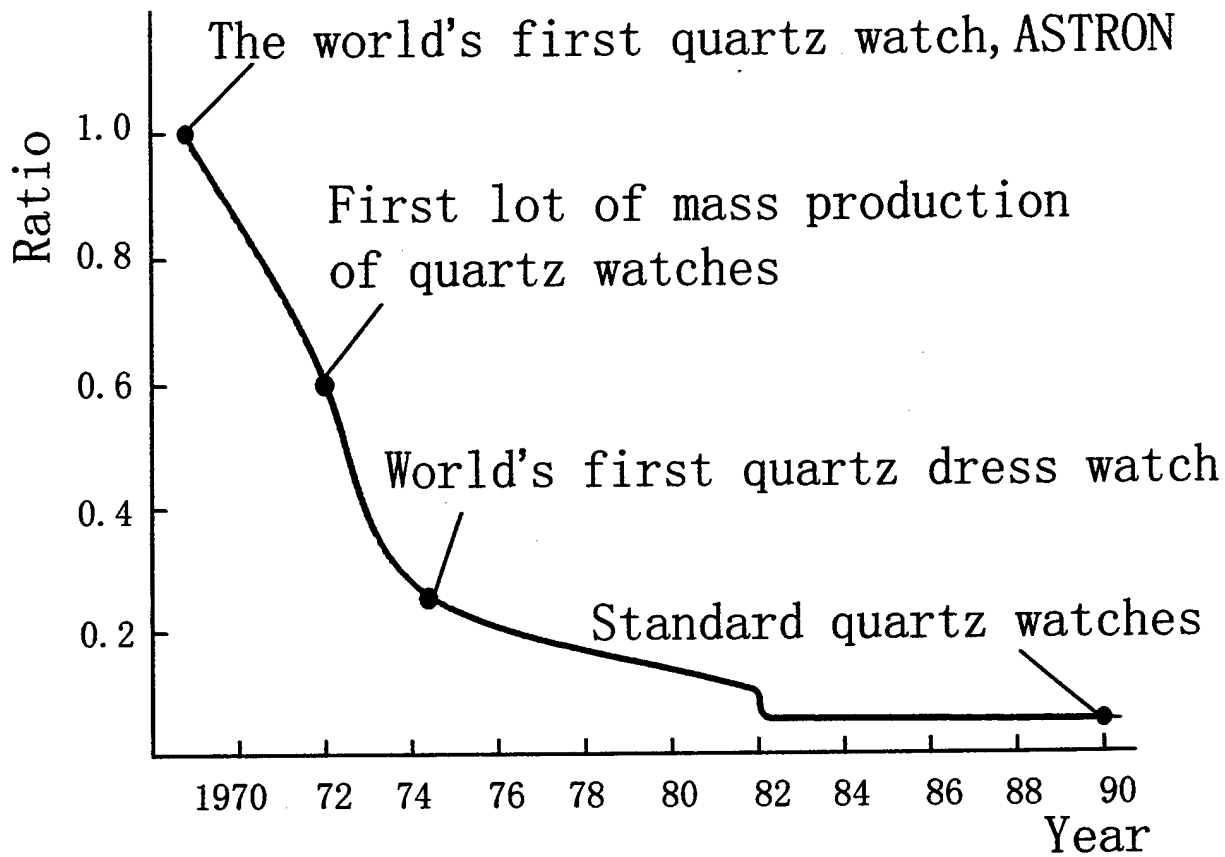

## Trend in electrical current consumption ( Seiko Epson data)

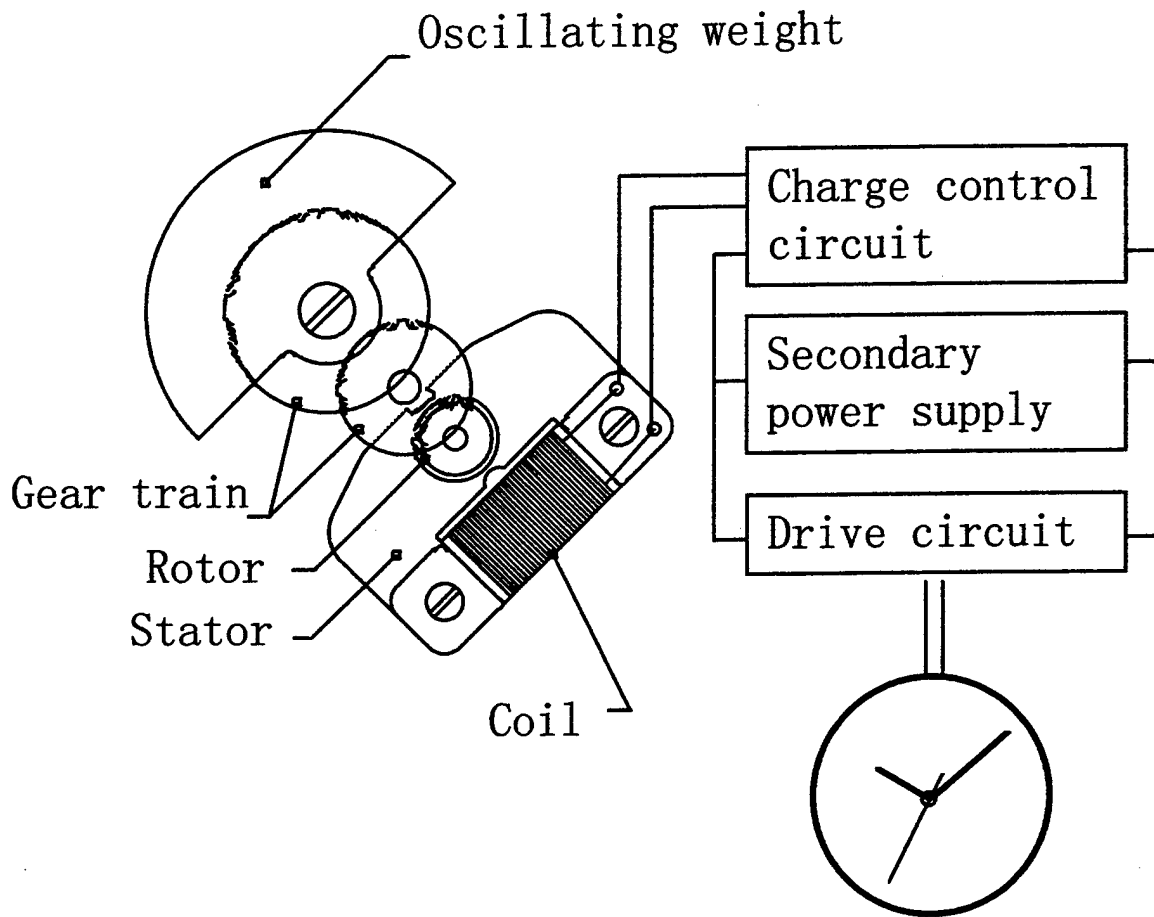

**AGS outline diagram**

## Movement Specifications

Type	5M	3M	4M
Outer diameter (mm)	$\phi$ 27.0	$\phi$ 23.3	$\phi$ 25.6
Thickness (mm)	4.3	4.2	2.7
Volume (mm <sup>3</sup> )	$2.57 \times 10^3$	$1.90 \times 10^3$	$1.48 \times 10^3$
Rotor magnet	Sm2Co17	←	←
Oscillating weight	Heavy metal (tungsten)	←	←
The number of coil turns	3700	3900	3600
Accelerating ratio	94.6	93.9	95.2

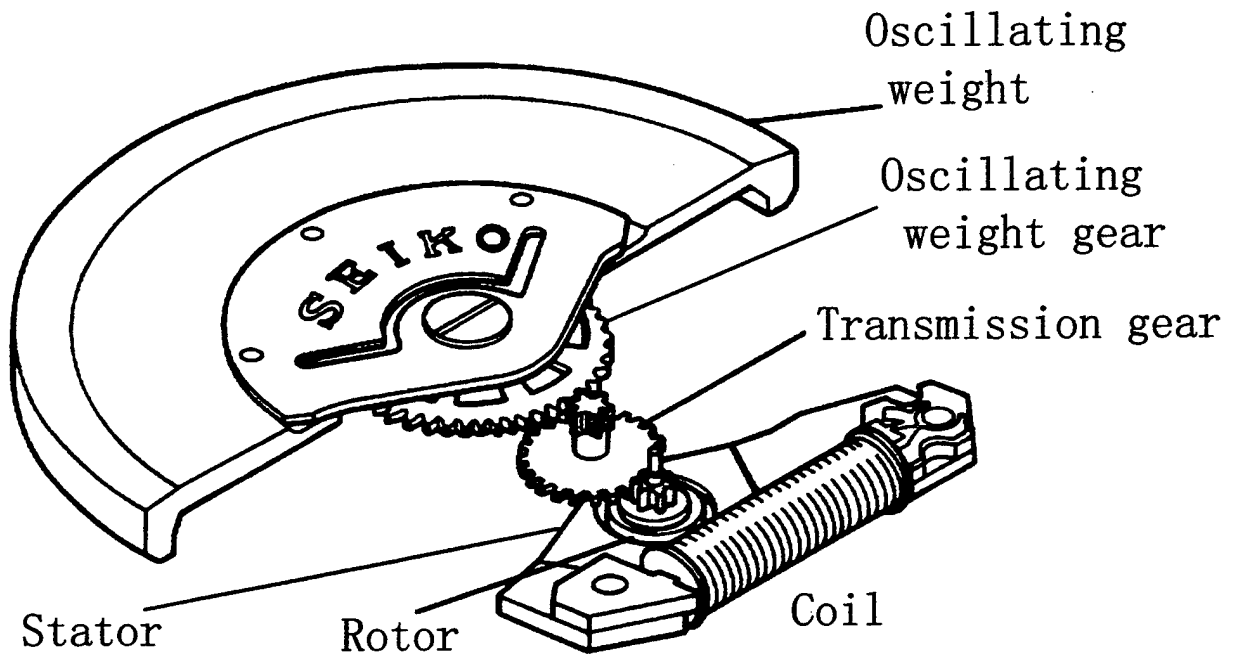

**Oblique view**

$$e = - N \frac{d \phi}{d t}$$

$e$  : Inductive-emf

$N$  : The number of coil turns

$\phi$  : Flux

$t$  : Time



$N$  : 3500~4000 Turns

$\phi$  : Rare earth magnet ( $\text{Sm}_2\text{Co}_{17}$ )

Accelerating ratio : 90~100 Times

**Inductive-emf**

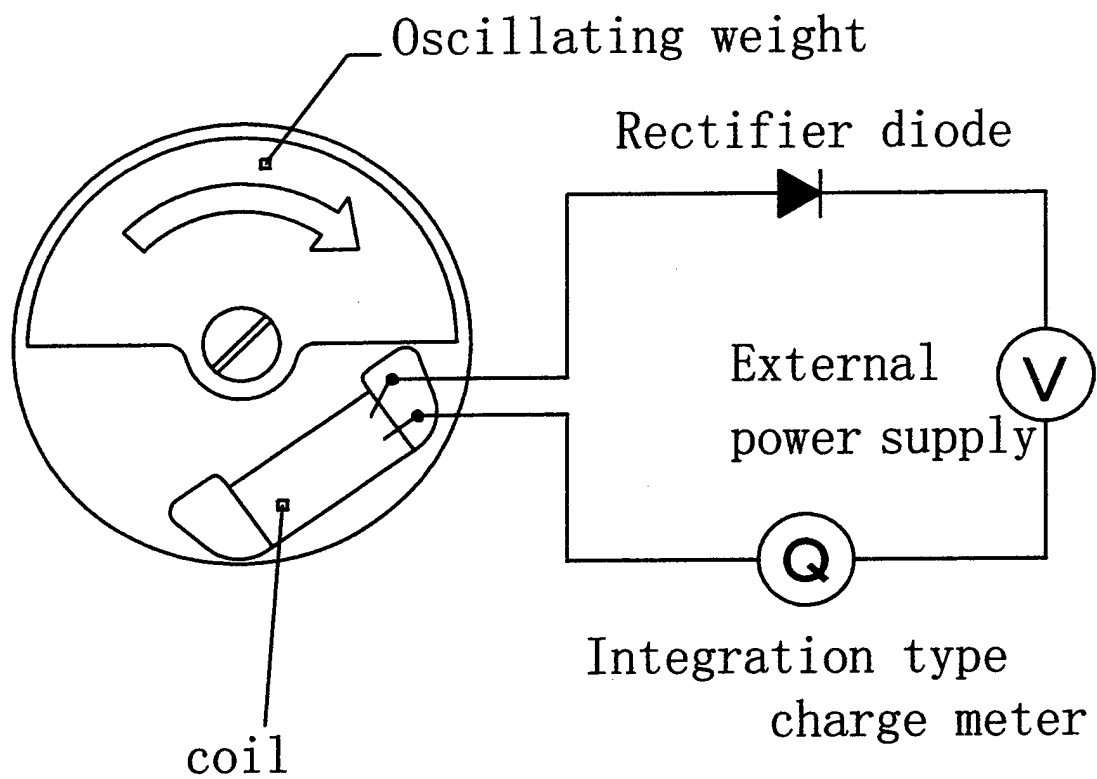

## Generated charge measurement

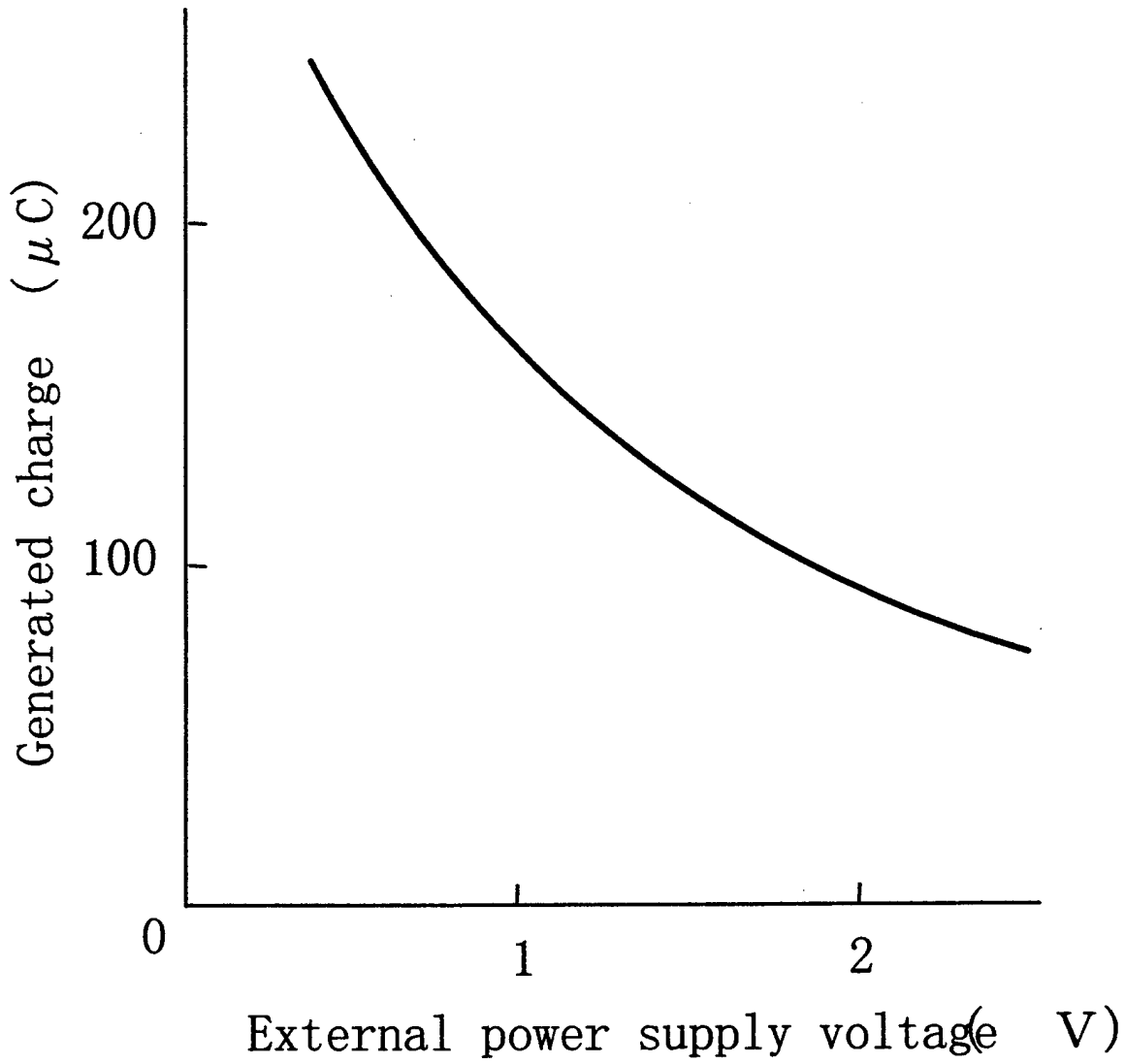

**Generated charge**

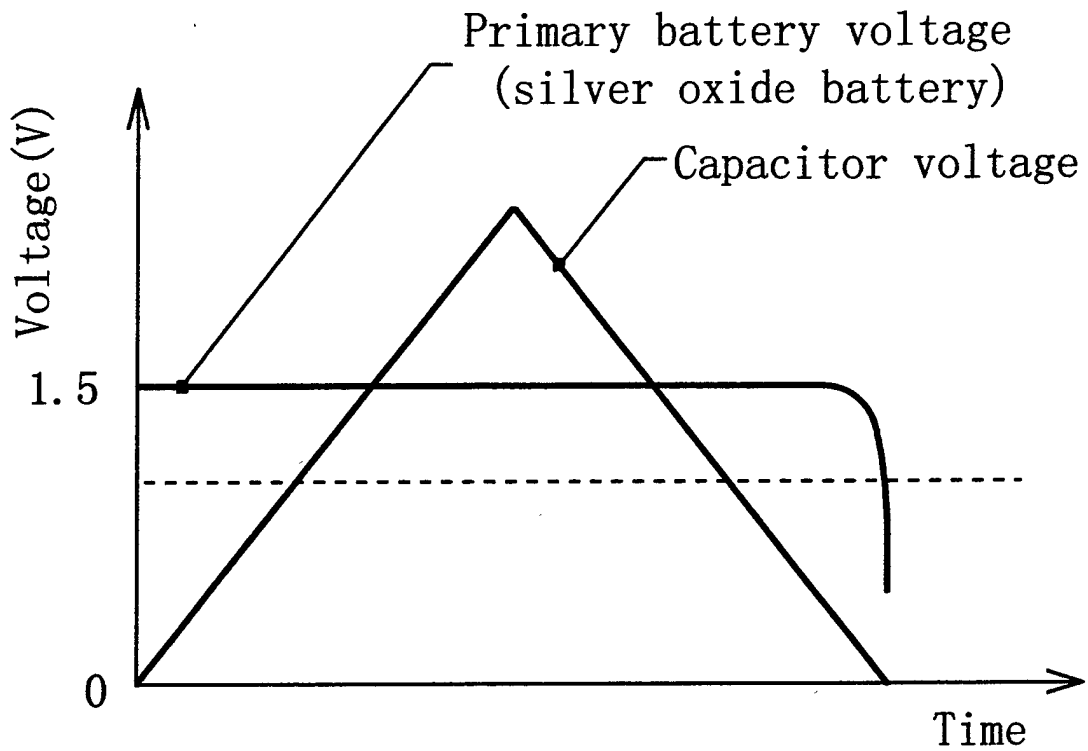

**Comparison of power supply voltage**

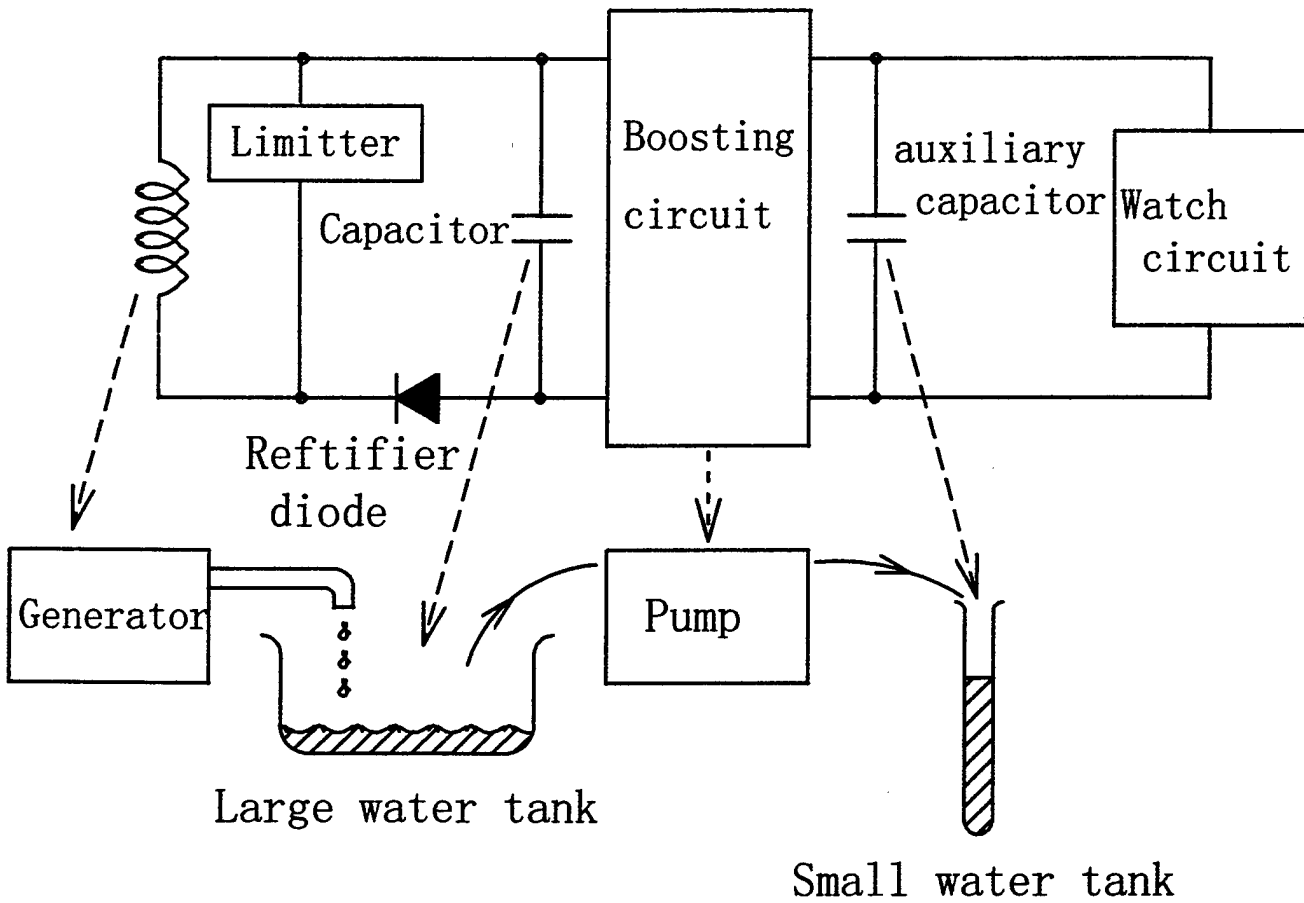

**Boosting drive system  
outline diagram**

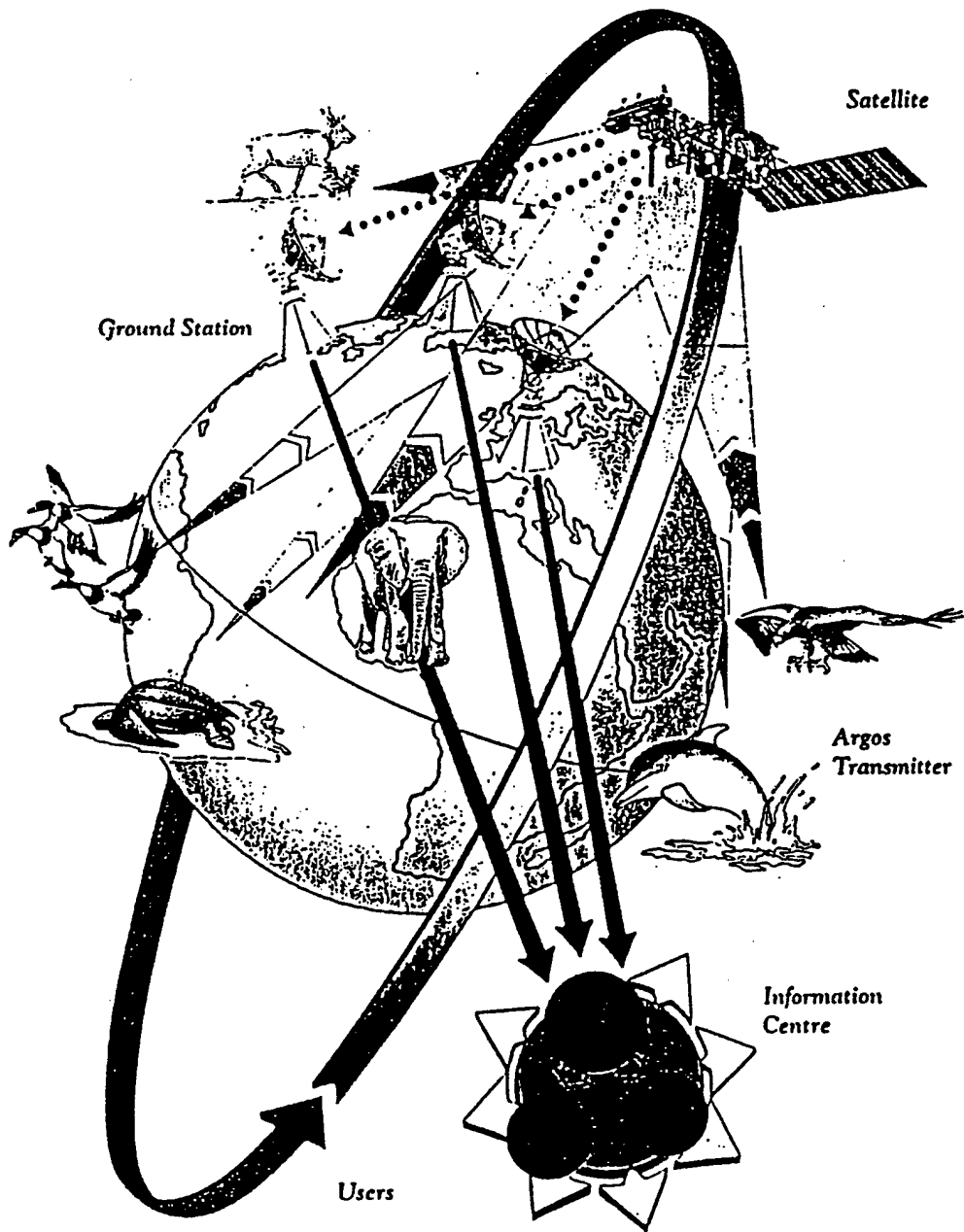

## Major characteristics of probe

<b>Mechanical Characteristics</b>	
Shape;	Football shape
Dimension;	Long axis...30 cm Short axis...15 cm
Weight;	10 kg
<b>Power system</b>	
Generating power;	2 W
Power generator;	Kinetic power generator
<b>Telemetry system</b>	
Uplink frequency;	UHF
Uplink modulation;	1200 bps Manchester-code/PM
<b>Sensor system</b>	
GPS receiver;	
Geomagnetic field sensor(Flux gate type),	
Water pressure sensor;	
Thermometer;	
Acoustic sensor;	

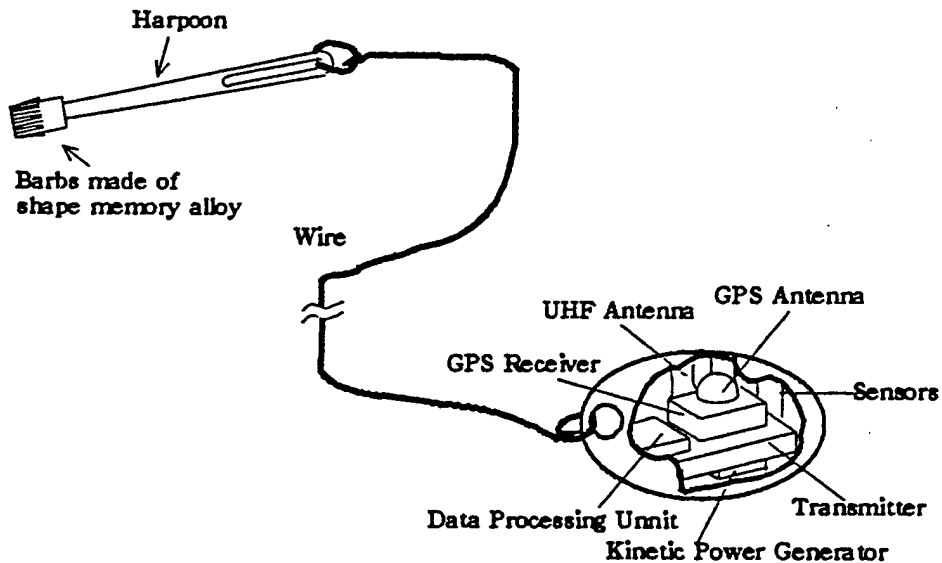

External View of Probe

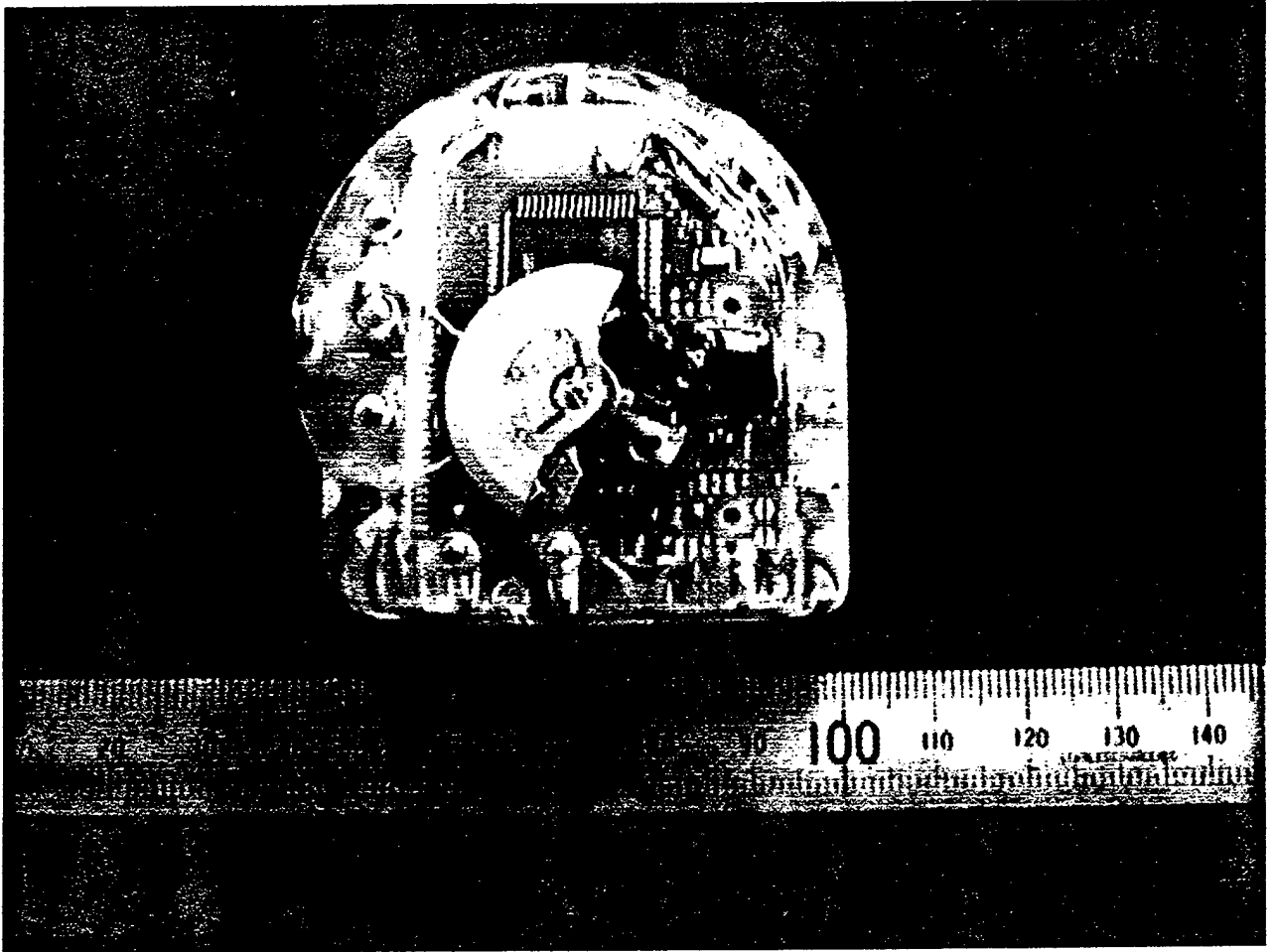

AGS application

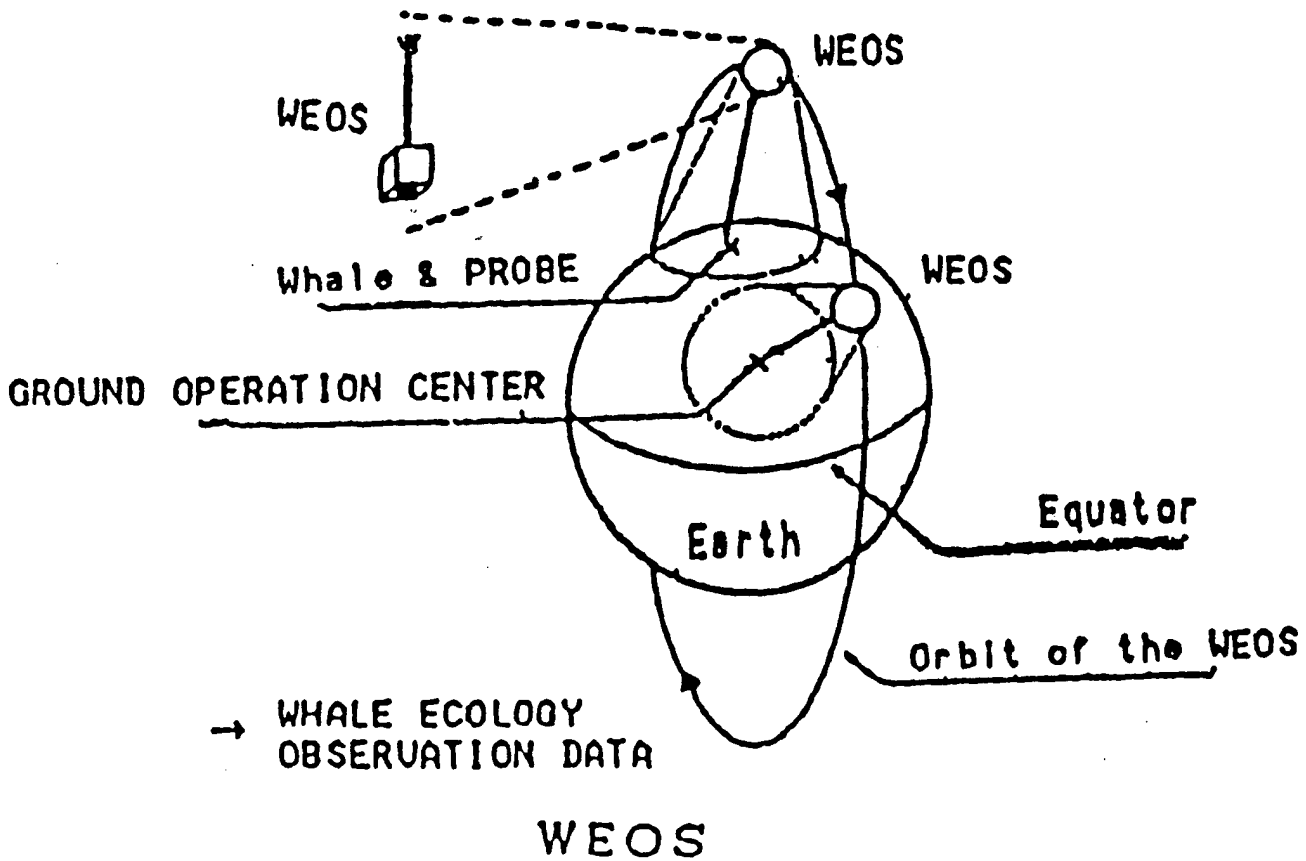
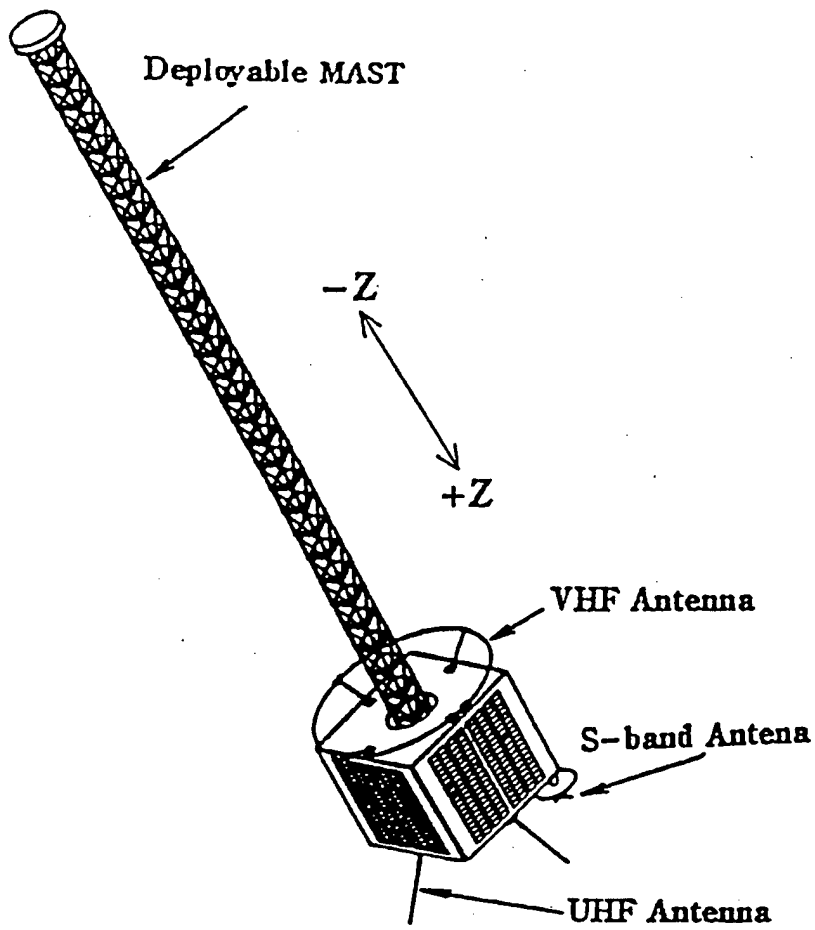

**“OVERVIEW OF DEVELOPMENTS IN SOUTH AFRICA”**

**(UNAVAILABLE)**

**Mr. Etienne Rijkheer**

**SYZYG  
Capetown, South Africa**



**“TECHNOLOGICAL CHALLENGES FOR HUMAN  
POWERED SYSTEMS”**

**Mr. J. Eric Tkaczyk**

**General Electric Corporate Research and Development  
Schenectady, New York**



GE Research  
& Development Center

# Technological Challenges for Human Powered Systems

presented at the  
Prospector IX

by

J. Eric Tkaczyk

*General Electric Corporate Research and Development*



# Outline

Strategy for an adaptable power system

Technologies:

- mechanical to electrical conversion
- energy storage tradeoffs
- voltage conversion benefits
- packaging to minimize perceived effort

Advancing the state of the art

## Human Powered Systems:

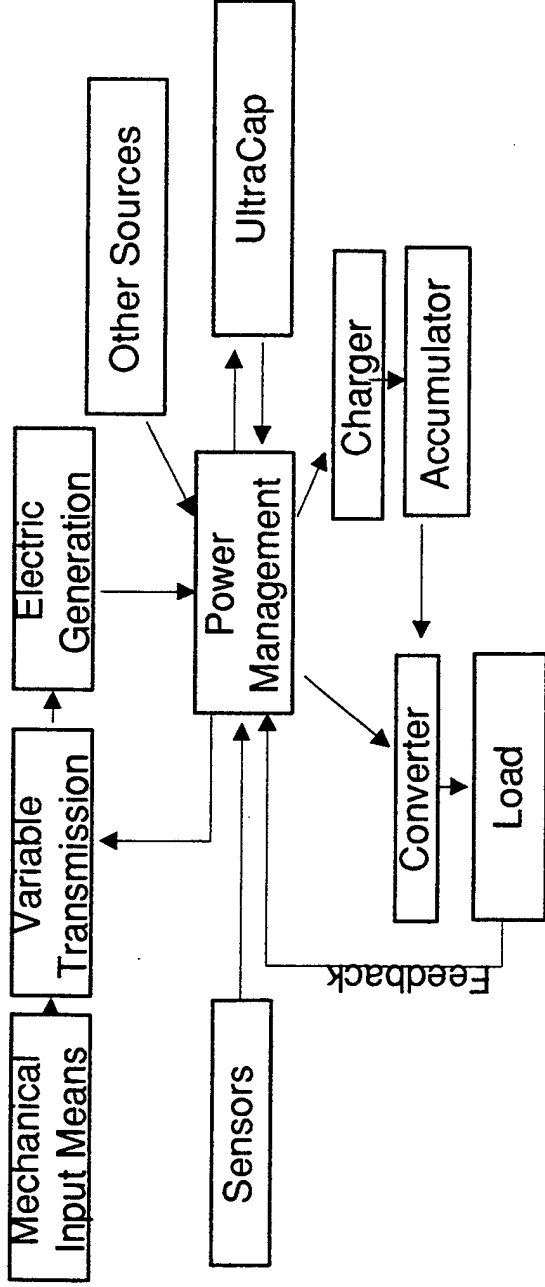

- efficient, reliable, adaptable
- minimum perceived effort
- variable frequency and duty cycle
- diverse load requirements
- adverse environmental conditions

# Mechanical to Electrical Conversion

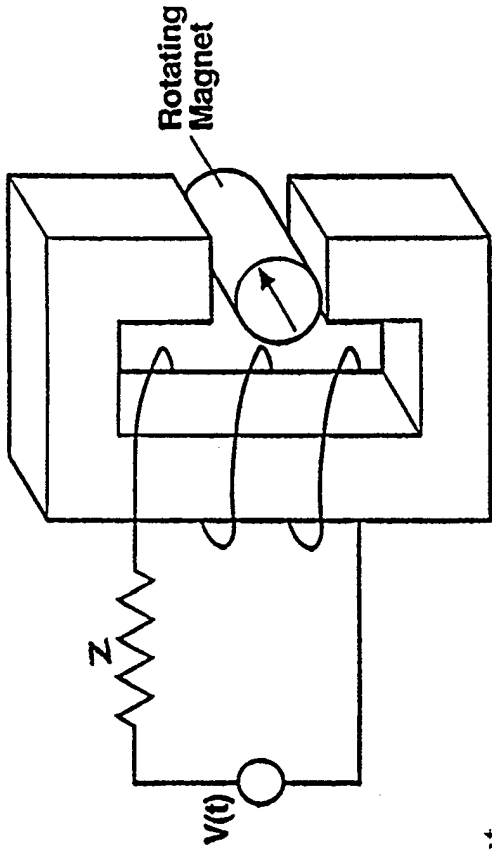

$$V = Iz + n \frac{d\Phi}{dt}$$

Input Power  $\rightarrow \tau_s \omega = \tau_0 \omega + \rho \omega^2 + k_B I \omega = \tau_0 \omega + \rho \omega^2 + M + I^2 Z$  Output Power

torque constant  $\rightarrow$  linear  $\rightarrow$  quadratic  $\rightarrow$  ohmic

losses

$$\eta = \frac{IV}{\tau_s \omega} = \frac{1 - \tau_0 / \tau_s}{1 + Z/R}$$

efficiency

# Generator Construction Tradeoffs

$$V = k\omega = (pn\Phi)\omega$$

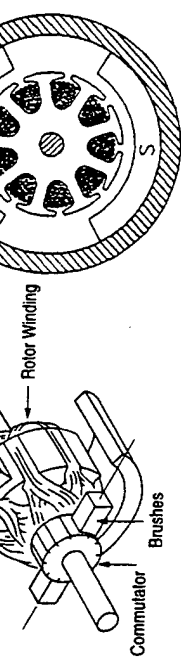

# poles   # turns   flux   frequency

$n \rightarrow$  resistive losses

$\Phi \rightarrow$  hysteresis losses  $\sim B^2$

$\omega \rightarrow$  frictional losses

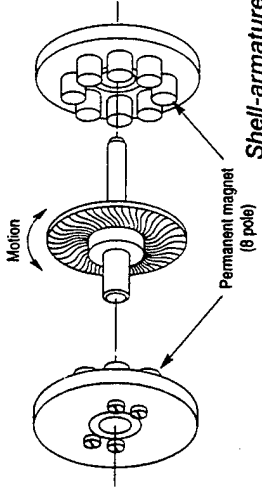

Shell-armature motor

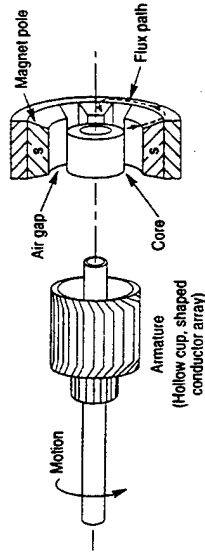

Brushless Motors

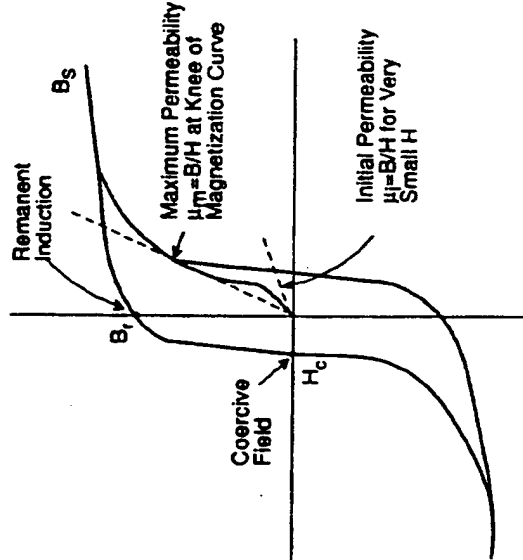
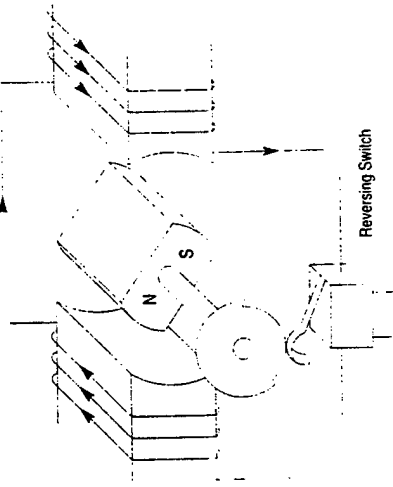

# TYPICAL MAGNETIC PROPERTIES OF COMMON PM MATERIALS

Br (kGauss)

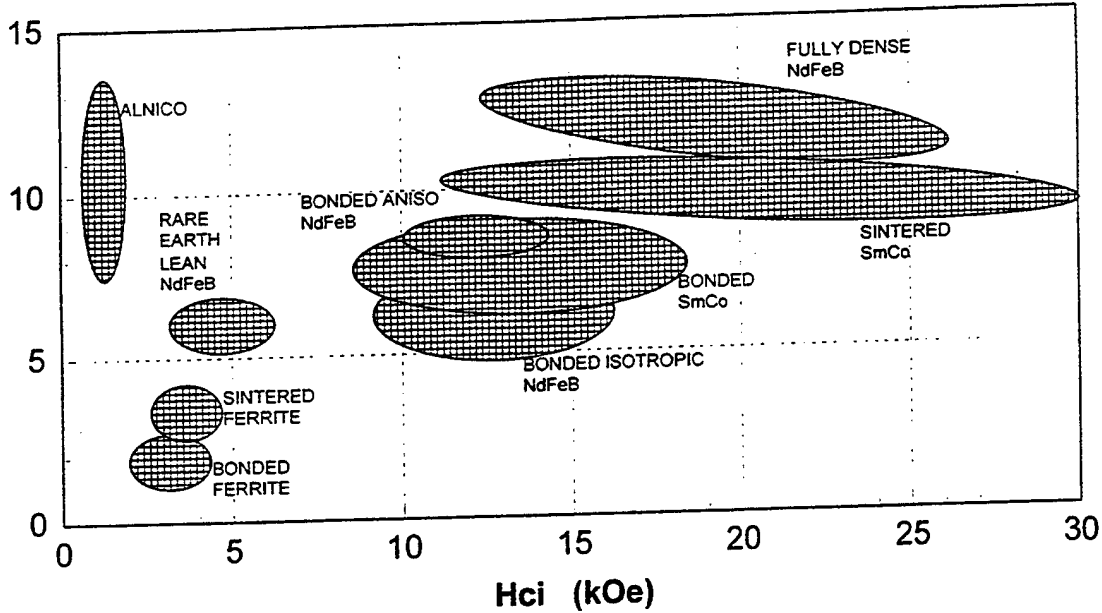

**ARNOLD**<sup>TM</sup>  
THE ARNOLD ENGINEERING COMPANY

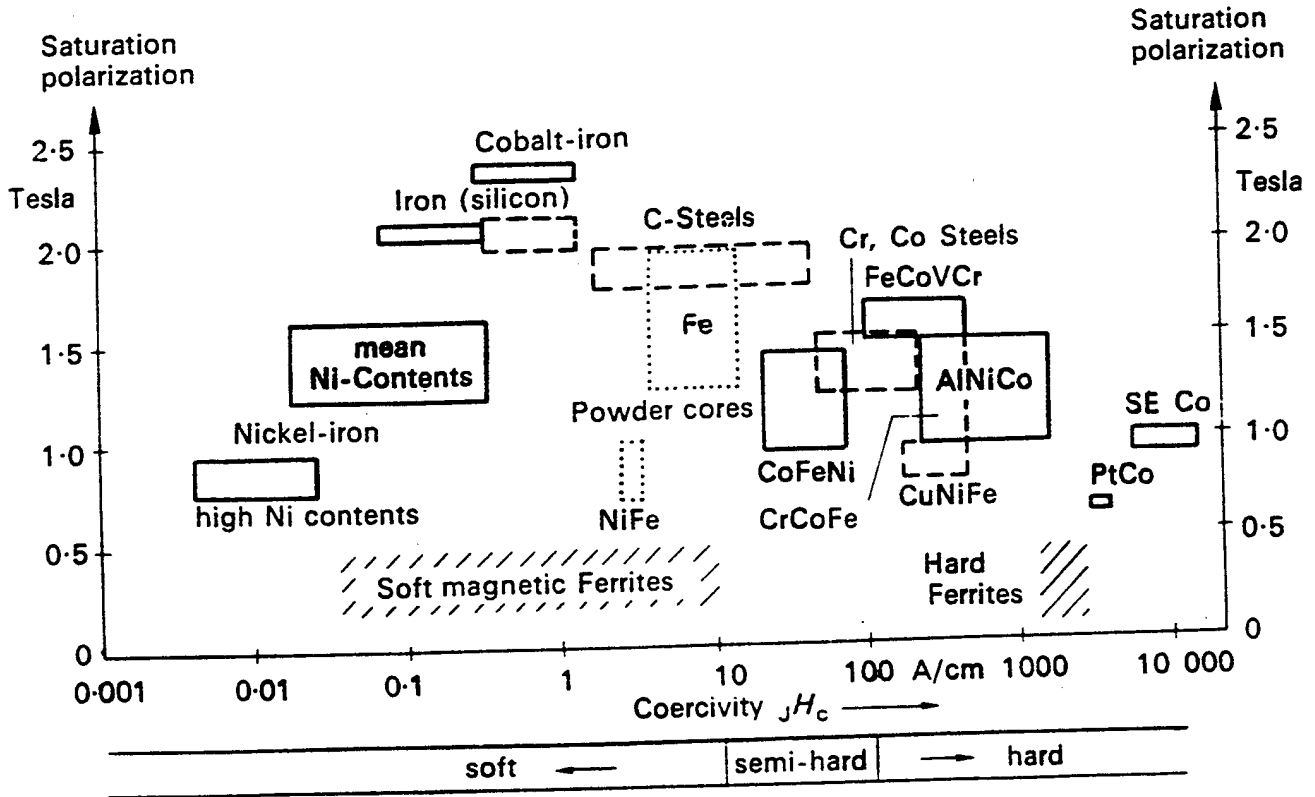

**Bonded Magnet Technology:  
Integration of Magnet and Gear Elements**

---

**WIDIA**

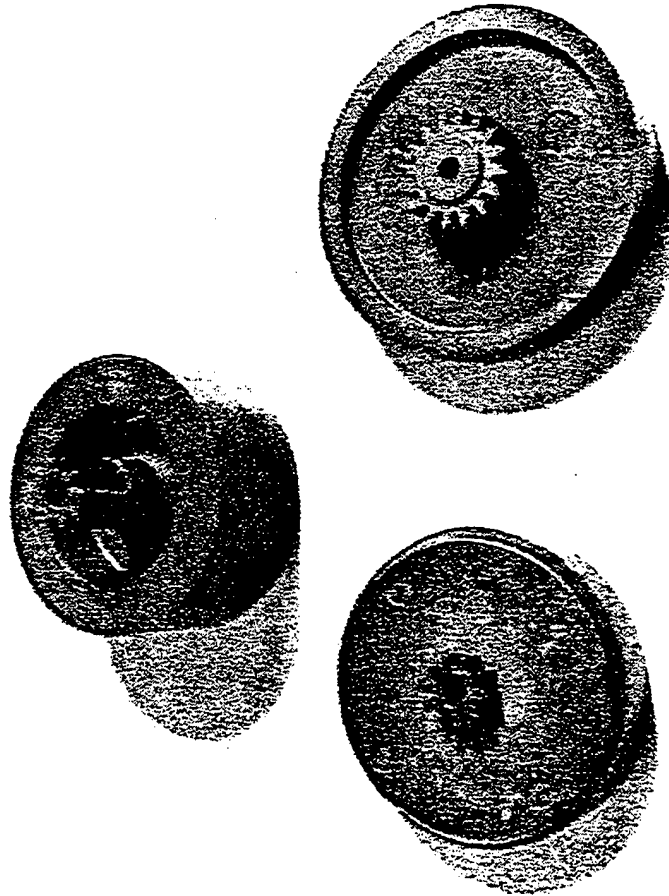

## High Speed Rotor:

optimized for both magnetic and mechanical performance  
high-strength conductor (Glidcop: Cu+Al<sub>2</sub>O<sub>3</sub>)  
special heat treatment for Si-Fe lamination strength

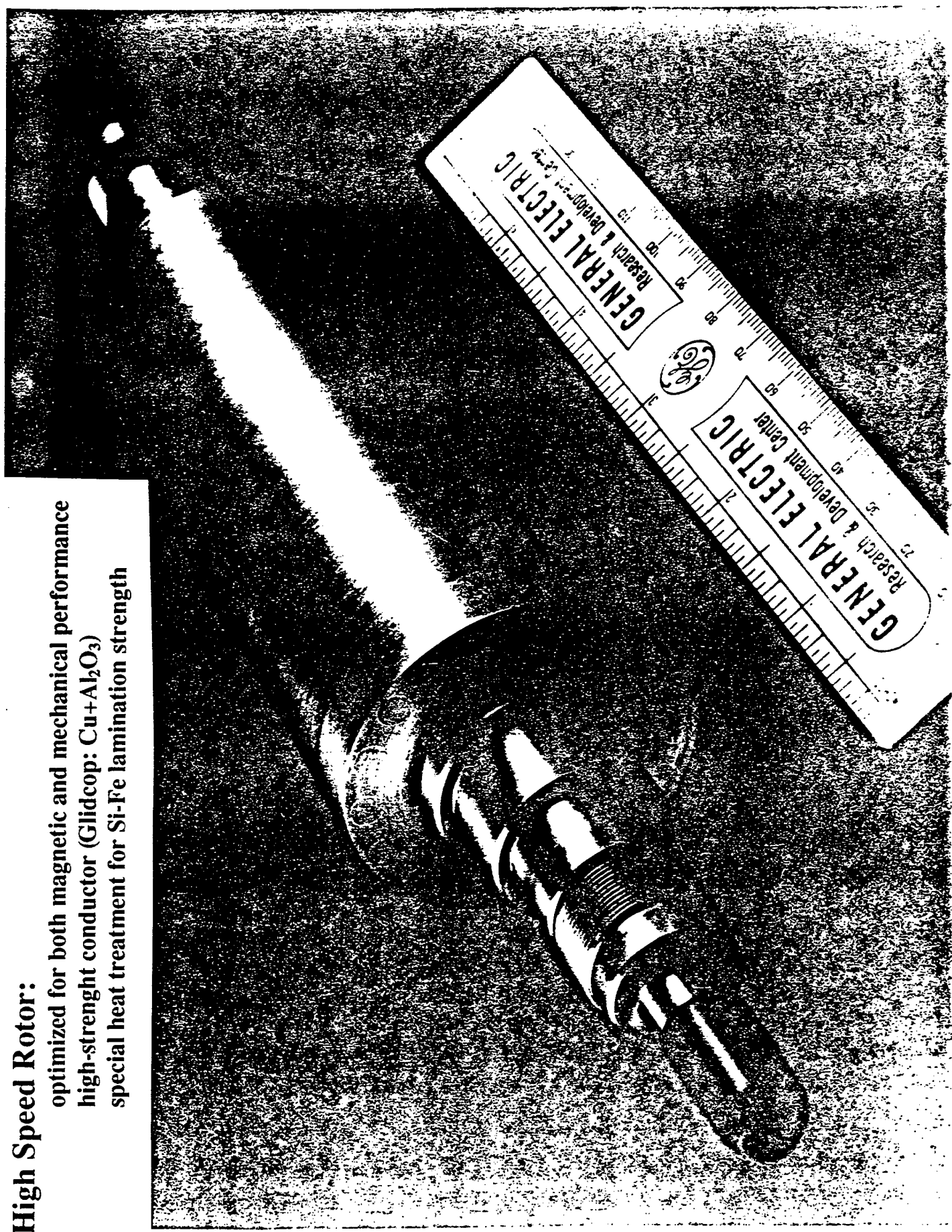

# Case Study - Micro-Generator for 'Smart Diskette'

A permanent magnet generator had to be designed to fit within an overall space envelope of 70mmx34mmx3.3mm and be capable of supplying a min. current of 20mA at 5Vdc.

## Generator Topology

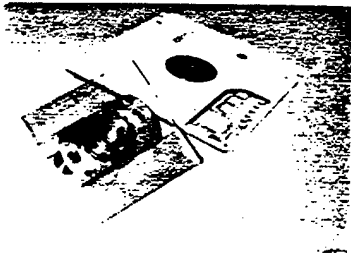

- The preferred topology is a 2-phase machine with a 32-pole axially magnetised sintered NdFeB magnet and cobalt steel laminations

- The magnet flux is focused to two concentrated coils.

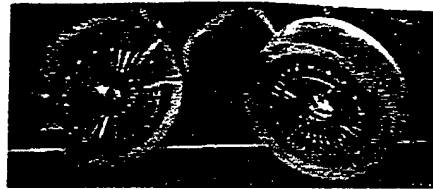
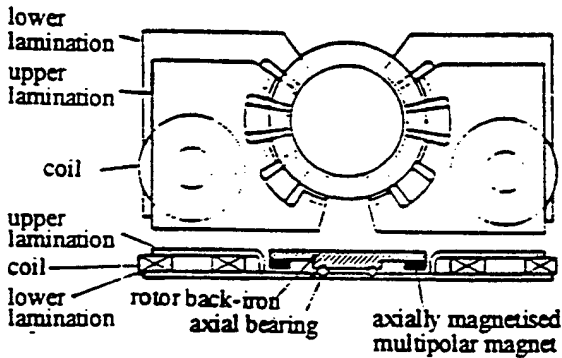

## Rectification/Smoothing Circuit

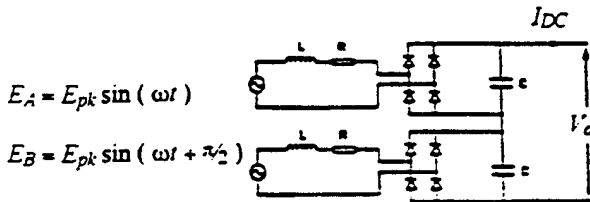

- Of the various possibilities a series connection of the rectified and smoothed outputs is the most efficient.

## Design Optimisation

- Coil flux =  $1.7e-05$  Wb
- Coil permeance =  $4e-07$  Wb A
- Coil OD = 0.019 m
- Coil ID = 0.006 m
- Coil thickness = 0.0022 m

- An optimum combination of number of turns/coil and smoothing capacitance enables max. current to be drawn before output voltage falls below 5Vdc.

Number of turns  $\leftrightarrow$

	620	650	700	750	800	850	900	950	1000
2p-0.6	2.20	3.00	3.50	4.00	4.50	5.00	5.50	6.00	6.50
2p-0.6	3.00	7.00	12.00	14.00	16.00	17.00	17.00	18.00	18.00
2p-0.6	6.30	22.00	16.00	18.00	18.00	19.00	19.00	19.00	19.00
3p-0.6	21.00	25.00	28.00	29.00	29.00	29.00	29.00	29.00	29.00
3p-0.6	23.00	26.00	28.00	29.00	29.00	29.00	29.00	29.00	29.00
4p-0.6	23.00	26.00	27.00	28.00	28.00	27.00	27.00	27.00	26.00
7p-0.6	23.00	23.00	24.00	27.00	27.00	27.00	26.00	26.00	26.00
8p-2.6	22.00	24.00	25.00	26.00	26.00	26.00	26.00	26.00	25.00

Maximum load current for 5V output (mA)

- Optimum values are established by system simulation and determining max. current capability for different combinations of number of turns and capacitance.

# Computer-Aided Design

Electrical drive systems are a multi-disciplinary technology, with each of the component disciplines developing rapidly. These are creating significant opportunities for meeting the market demand for drive systems with higher performance, improved energy efficiency and better reliability. CAD is also playing a vital role since it allows the merits of alternative drive formats to be assessed on an application-by-application basis, and maximum leverage to be extracted from any grade of permanent magnet. It also permits an integrated design approach, and optimisation at the system level.

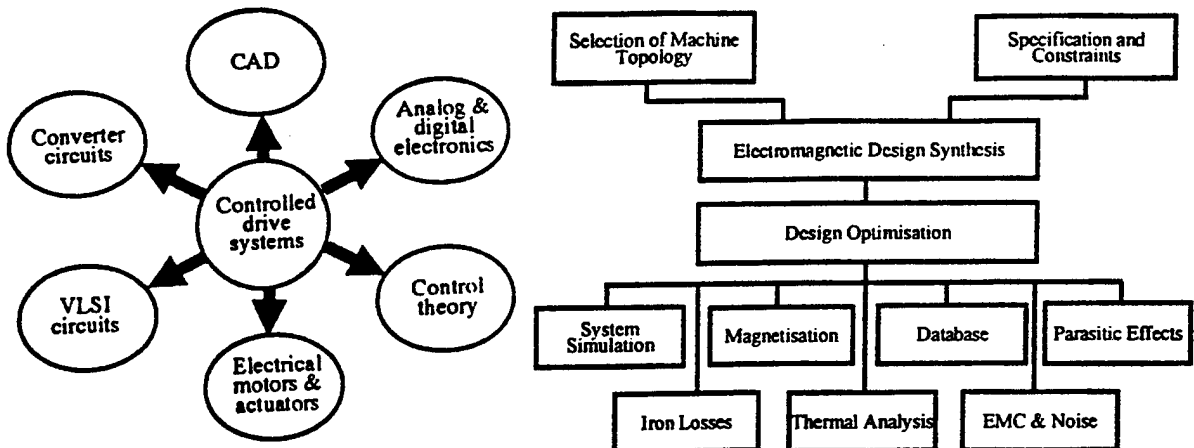

CAD can cater for a wide variety of motor/actuator configurations as well as the systems by which they are controlled.

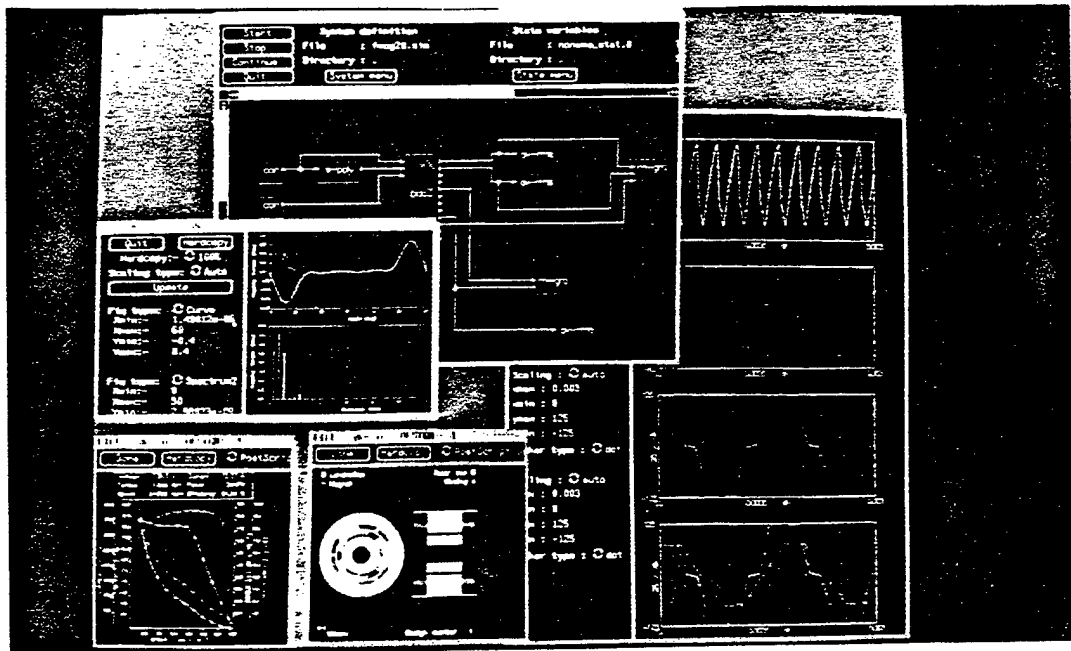

Advanced CAD facilities enable the feasibility of new product concepts to be assessed with confidence.

# SAE Technical Paper Series

## Elastomeric Regenerative Braking Systems

L. O. Hoppie

Corporate Research Dept.  
Eaton Engineering and Research Center  
Southfield, MI

### ABSTRACT

A theoretical and experimental investigation into the use of elastomers as the energy storage element of a regenerative braking system for urban vehicles is being carried out. This work has included the design and fabrication of full-scale elastomeric energy storage units which were tested to investigate energy density, efficiency and stress-relaxation. A complete small-scale system which simulates a vehicle was tested during transient speed conditions, and a complete full-scale system to be laboratory tested is under construction.

THE PRICE INCREASE OF PETROLEUM-BASED fuel in the past few years has given rise to various research and development efforts for energy conservation. An example of such efforts is aimed at regenerative braking systems for land vehicles. With such a system, kinetic energy is converted to stored as the vehicle energy is subsequently kinetic energy when the Because a part of the eipated as heat in the br accelerate the vehicle, energy required to pr reduced.

The prime energy c system depends on the d efficiency of the system a highway truck typical hundred miles between : little savings even if a braking system were avai hand, studies of typica Federal Urban Driving C

\*Numbers in parentheses c at end of paper.

that more than one-third of the energy supplied to the driveline is ultimately dissipated in the brakes. If an ideal regenerative braking system were available, the range per unit of energy measured at the driveline could thus be increased by about 50 percent for this cycle.

Obviously, if there are more stops per mile in a driving cycle, even higher improvements are possible. Consequently, applications such as city buses, delivery vans and subways are particularly attractive for regenerative braking systems.

In order for a regenerative braking system to be cost-effective, the prime energy saved over a specified lifetime must offset the initial cost, size and weight penalties of the system. Consequently, the energy storage unit must be compact, durable and capable of handling high power levels efficiently, and any auxiliary energy transfer or energy conversion equipment must be efficient, compact, and of reasonable cost.

A regenerative braking system based on

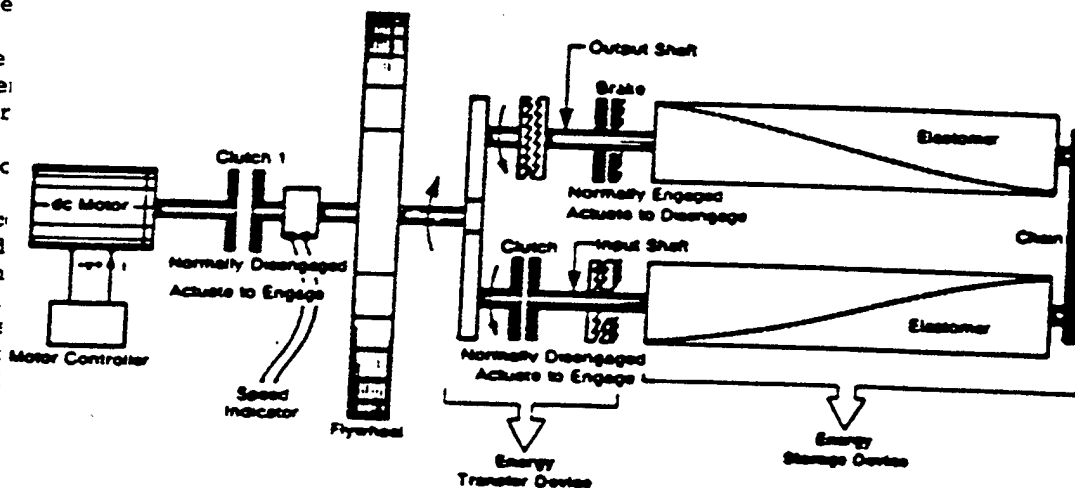

0148-7191/83/0228-0112\$02.50

Copyright 1983 Society of Automotive Engineers, Inc.

## Secondary Battery Comparisons:

### RECHARGEABLE ALKALINE

- Best: Not clear
- Worst: Limited cycle life

### SILVER ZINC

- Best: High reliability
- Worst: High cost

### LEAD ACID

- Best: Mature, Long storage life, Low cost
- Worst: Heaviest

### NICKEL CADMIUM

- Best: Mature, High peak current, Large cycle life
- Worst: Heavy, Memory effect

### NICKEL METAL HYDRIDE

- Best: Lighter, Environment safe
- Worst: Cost, Self discharge, Complicated charging

### LITHIUM

- Best: Light weight, High voltage
- Worst: Critical charging, Cost

### ZINC AIR

- Best: Lightest weight
- Worst: Not in production

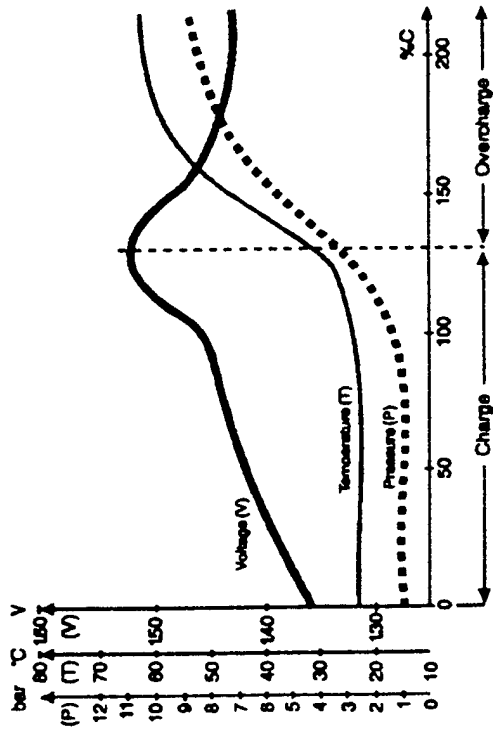

NiCd Charge Characteristics

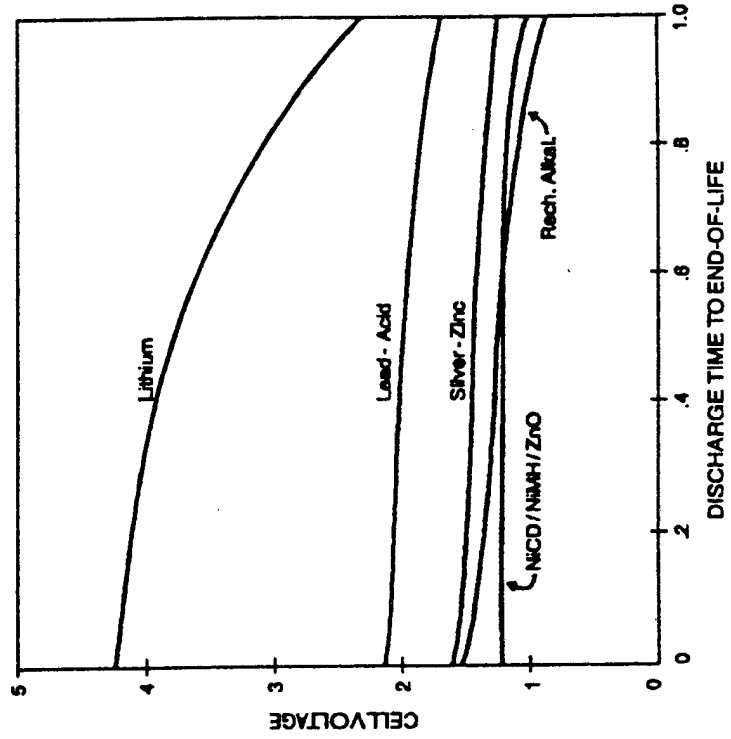

Normalized Cell Discharge Voltages

# AN OVERVIEW OF BATTERY TECHNOLOGIES

## RECHARGEABLE BATTERY DATA SHEET

ELECTROCHEMISTRY	UNITS	RECHARGEABLE BATTERY DATA SHEET						
		SEALED LEAD-ACID	PEP-SLA THINLINE	NICKEL-CADMIUM	NICKEL-M/HYDRIDE	RECH. ALKAL.	ZINC-AIR	LITHIUM ION
NOMINAL CELL VOLTAGE	vpc	2	2	1.2	1.2	1.5	1.2	3.7
ENERGY DENSITY GRAVIMETRIC (SPECIFIC ENERGY) VOLUMETRIC (ENERGY DENSITY)	Wh/kg	35	46	50	64	76	150	125
	Wh/l	80	110	120	180	219	160	250
CHARGE ACCEPTANCE IN-RUSH CURRENT TIME TO FULL CHARGE	C amps	7	7	2	1	1	0.04	POOR
	hours	<4	<4	<1	>1	>3	>24	POOR
OVERCHARGE RESISTANCE FLOAT LIFE @ 20°C	years	5-20	8	N/A	N/A	0.5	N/A	POOR
OVERDISCHARGE RECOVERY CAPACITY ON RECHARGE	%	0-90	>90	>90	>90	>80	0	POOR
SELF-DISCHARGE RATE % RATED CAPACITY LOST/MONTH @ 20°C % RATED CAPACITY LOST/MONTH @ 40°C	%	2-4	3	15	30	0.5	5	5-8
	%	8-16	12	60	70	2	20	POOR
CYCLE LIFE (to 90% of rated capacity) 25% DOD @ C/5 - 2 CYCLES/DAY 50% DOD @ C/5 - 2 CYCLES/DAY 100% DOD @ C/5 - 2 CYCLES/DAY	cycles	1200	2200	2000	500	100	100	NA
	cycles	600	1000	1000	500	50	50	1000
	cycles	300	500	500	500	25	25	NA
COST PER WATT-HOUR	\$/Wh	\$0.10-0.60	\$0.50-1.00	>\$1.00	>\$1.50	\$0.33	\$1.25	>\$5.00

\*(after discharge to 0 volts and 28 day stand)

# Recharge 2-way radio batteries on *YOUR* coffee break!



Two-way radio batteries used to take 16 hours to recharge. And they burned out before the warranty expired. No more. ACT's Ultra-Rapid™ two-way radio battery charger delivers the fastest charge anywhere—*down to an incredible 20 minutes*. And it pumps up battery usable capacity. *Plus, ACT's charger conditions batteries while charging and delivers full capacity with every charge.*

Get ultra performance for your two-way radio batteries. Call 770.582.0001 today.

**ACT**  
**ACT**

The blue box that makes batteries better.

*“We got vast improvement in battery life and increased usable capacity... It also shortened full charges from 16 hours to just under 20 minutes.”*

— Mike A. Valencia  
DOD  
(using Motorola Radius)

# SETTING THE GLOBAL STANDARD FOR BATTERY CHARGING

*The Advanced Charger Technology (ACT) process works with the natural chemical processes within the battery to allow the battery to be charged at a maximum efficiency. This charging technology is universally effective on batteries of every major chemistry in wide use today.*

## Delivery Platforms Available

- Hardware Design, Mfg. and Delivery
- Circuit Board Level Components
- Pre-Programmed Chips
- Software

## Products Available

- Ultra-Rapid™ Two-Way Radio Charger

## Technology Features

- High Efficiency Charge
- Minimum Battery Heating
- Small Electrode Crystal Structure
- Minimum Battery Gassing
- Advanced, Precise Termination

## Technology Benefits

- Prolongs Battery Life
- Ultra-Rapid™ Charge
- Less Energy Usage
- Eliminates Memory Effect
- Higher Asset Utilization
- Environmentally Friendly

*The ACT Operating System will provide battery dependent industries with a competitive advantage which will enable their battery powered devices to charge faster, last longer, and perform in a consistent and reliable fashion.*

*Three Patents Granted*

*Six Patents Filed*



01971M/PM/MGK  
Order Number: CGB02/R1

THE CHARGING STANDARD

# Ultracapacitor Technology

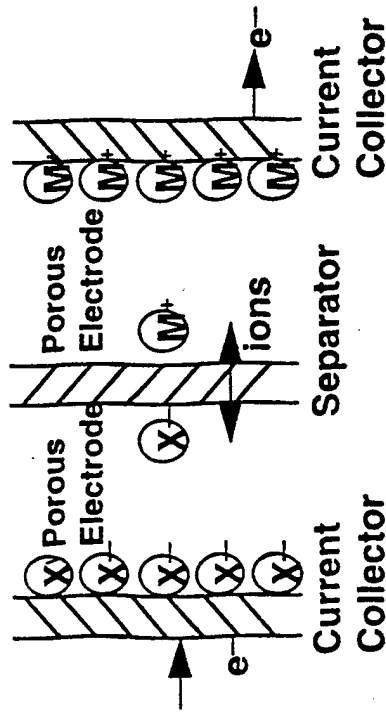

$$E = 1/2 CV^2$$

	Energy	Power	Time
Electrolytic	V.Low	V. Hi	uS-mS
Ultracap	Lo-Med	Hi	<S->Min
Battery	Hi	Lo-Med	Min-days

## Inherent Advantages

- No Mass transport or chemical changes occur
- Cycle life 100'sK cycles w/o change; only ions move
- Non-polarized - Only magnitude of voltage is limitation
- Environmentally benign while can be low cost

**Ultracapacitors: A High Power Source of Energy**

## Inherent Advantages of Ultracapacitors

- No change-of-state or mass transport phenomena
- Lifetime not limited by cycling regime
- No low voltage limit
- State of charge accurately found from open-circuit voltage
- Can be charged at same high rate as discharge: recharge time fast
- No maintenance required
- No moving parts
- Little or no ancillary plant
- Modular design is easy and advantageous
- Easily adapted to available space
- Environmentally benign compared to other chemical system
- Low cost materials can be used
- Sealing and packaging less complicated than with other chemical systems



*Ultracapacitor Program*

# Assembly—First 1000 Watt Stack

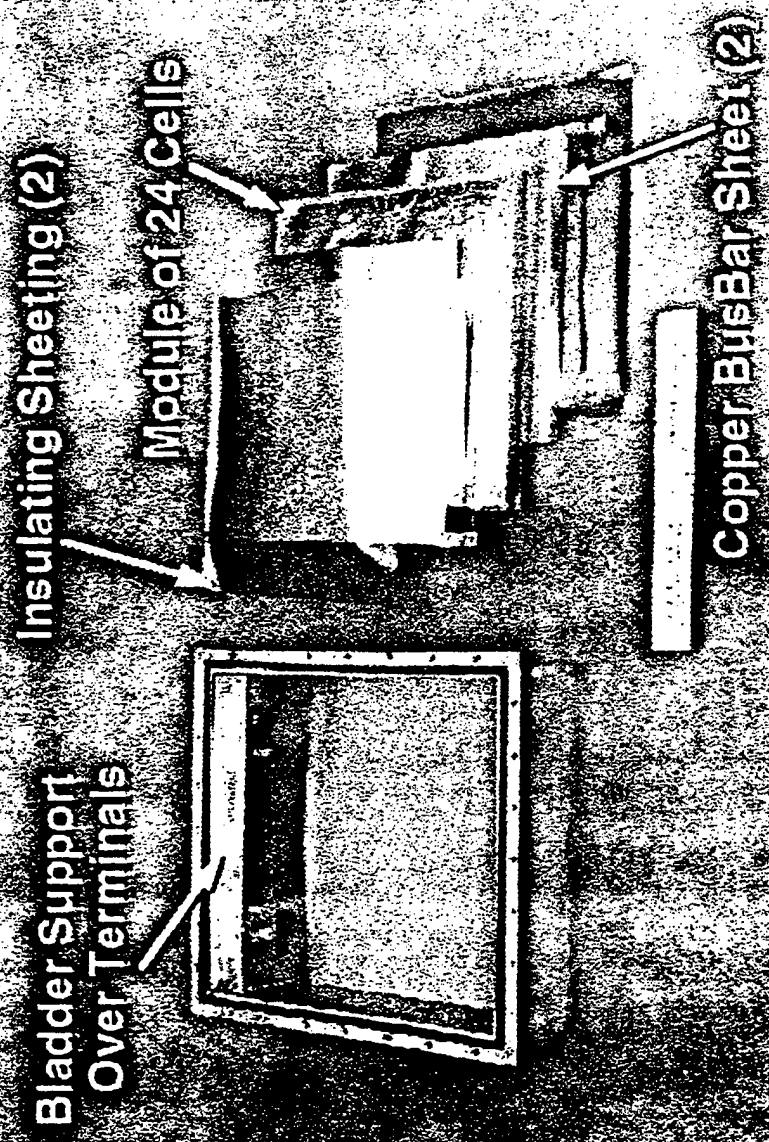

This document and its contents are the property of General Electric Company. All rights are reserved. Reproduction or transmission in any form or by any means without written authorization is prohibited. The Government shall have unlimited right in this data. This legend shall be marked on any reproduction of this data, in whole or in part.

# Voltage Conversion

- high efficiency
- power management through control circuitry
- design issues: EMI, spikes, ripple content
- short circuit protection
- component tolerances

406

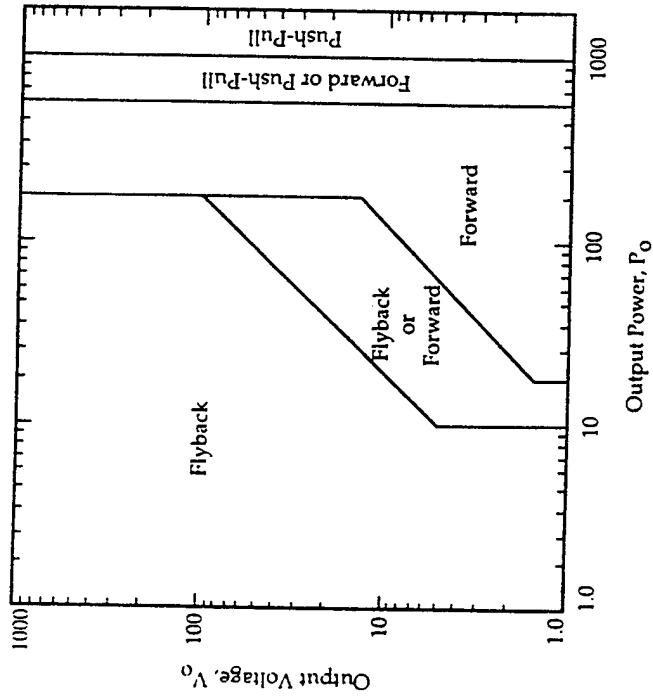

Converter choice as a function of SMPS output voltage,  $V_o$ , and output power  $P_o$ .

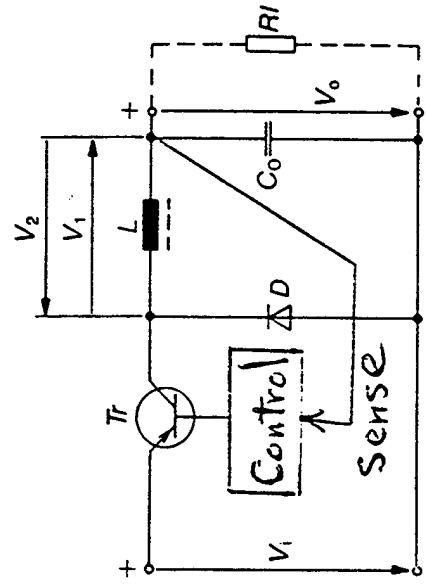

Fig. 1.2 Inductor-coupled step-down converter

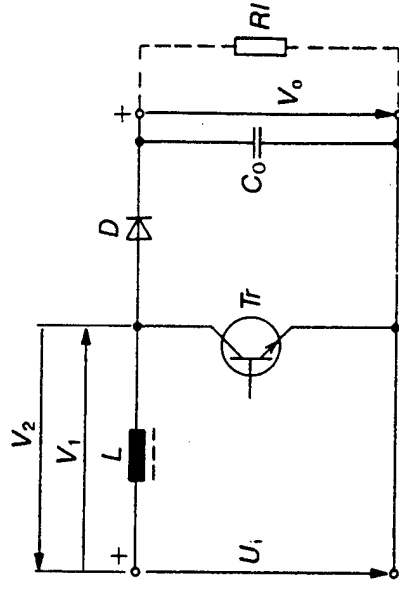

Fig. 1.3 Inductor-coupled step-up converter

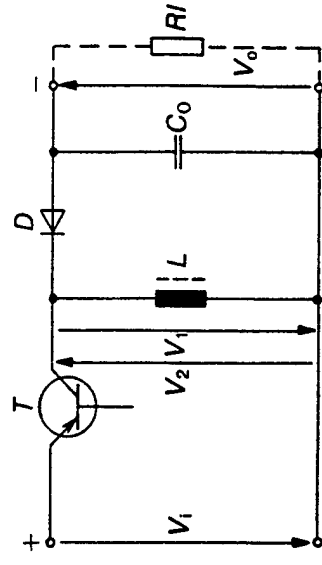
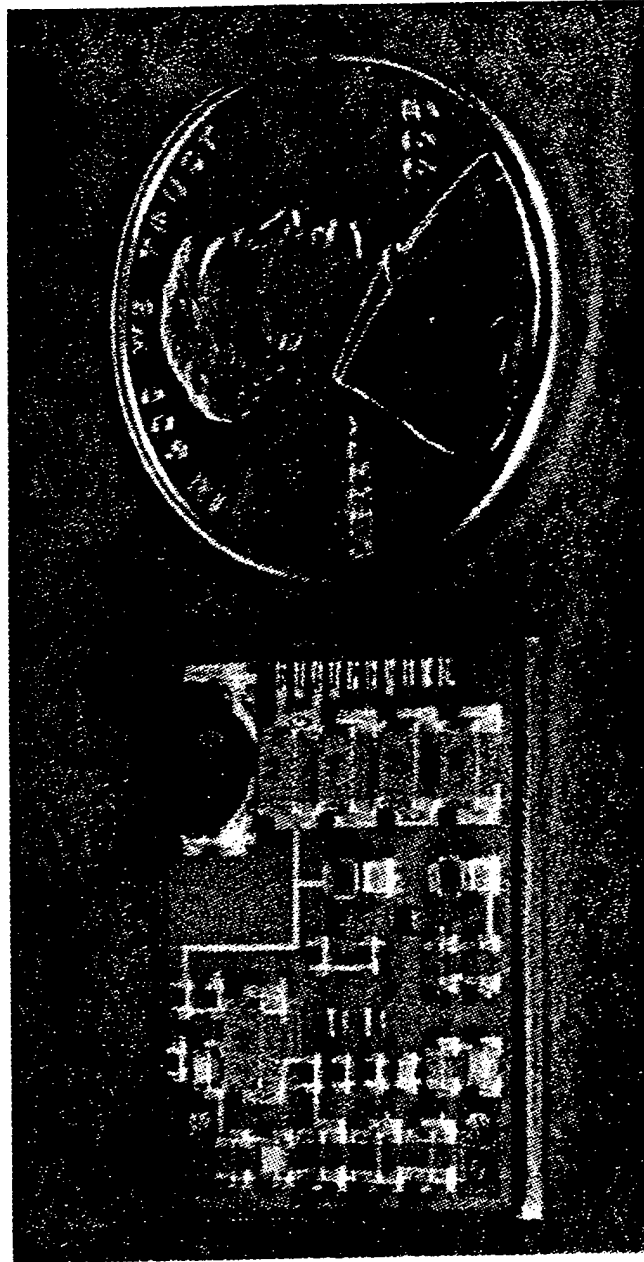
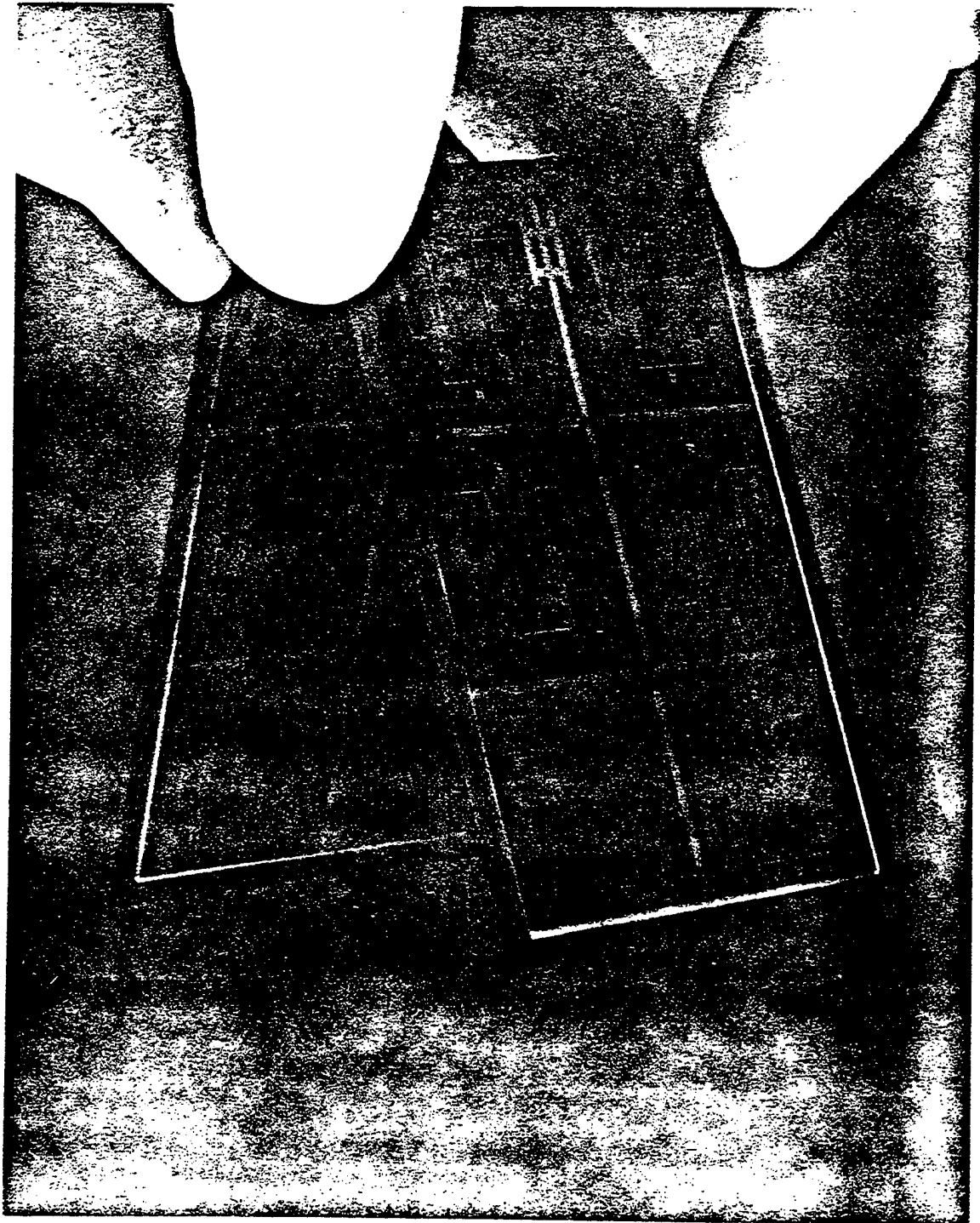

Fig. 1.4 Inductor-coupled flyback converter





## COF Advantages

- **Chip on Flex:**
  - die are fully encapsulated, protected.
  - fully testable while on flex or singulated.
- **Fully compatible with standard SMT:**
  - pick & place and handling equipment.
  - batch reflow solder processes, chemicals, temperature.
- **Can use die from any source:**
  - perimeter or area array.
  - Al or Au or any pad metal system.
- **Standard I/O array configurations:**
  - not effected by die shrinks.
  - not effected by switching vendors.
- **Applicable to wide range of chip complexities:**
  - from three terminal transistors to more than 400 I/O chips.
  - for RF, logic, power, analog and electro/optical.
- **Low cost, simple, robust process.**

Passivation

I/O Pad

Lead  
Frame

Cap

IC

IC

Encapsulation

Chip-on-Flex Multichip Module Cross-Section  
With Top Mounted Lead Frame



Corporate Research & Development

# HPSC DRAM Module

- Module Features:
- Memory Configuration: 8 Mbyte x 32
- Parity Error Detection
- Typical Power: 10W @ 5V
- Low Cost Chip on Flex Technology
- Module Size: 2.496" x 1.796"
- I/O - 157

Parts:

Qty	Type	Function
18	DRAM	Memory
3	ISPLSI1032	DRAM Controller
1	PAL22V10	DRAM Controller
9	180 nf	Capacitors

Total: 31

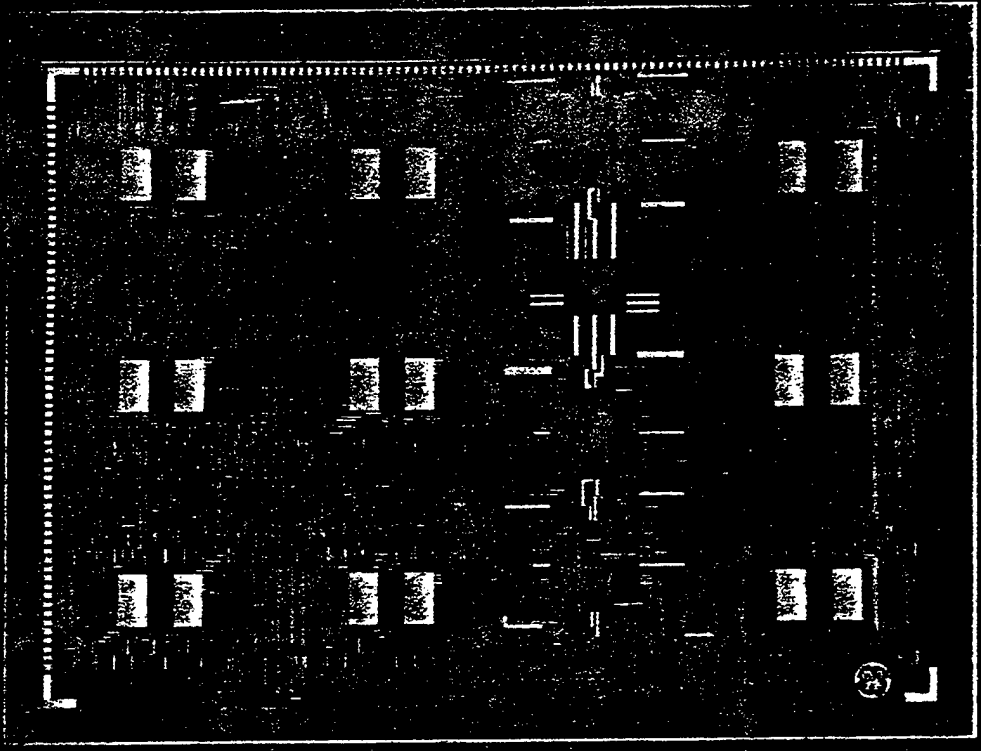

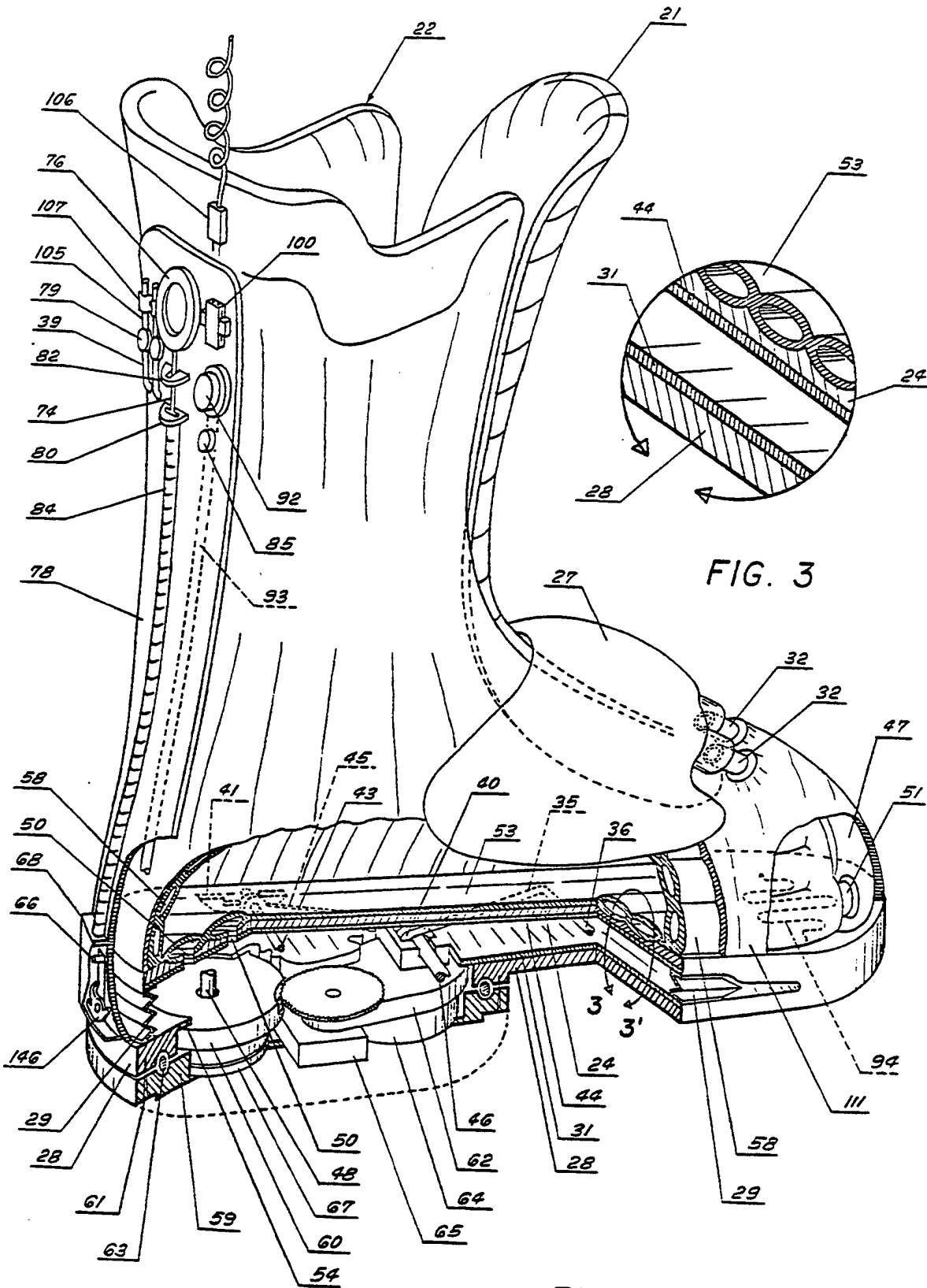

FIG. 2

FIG. 3

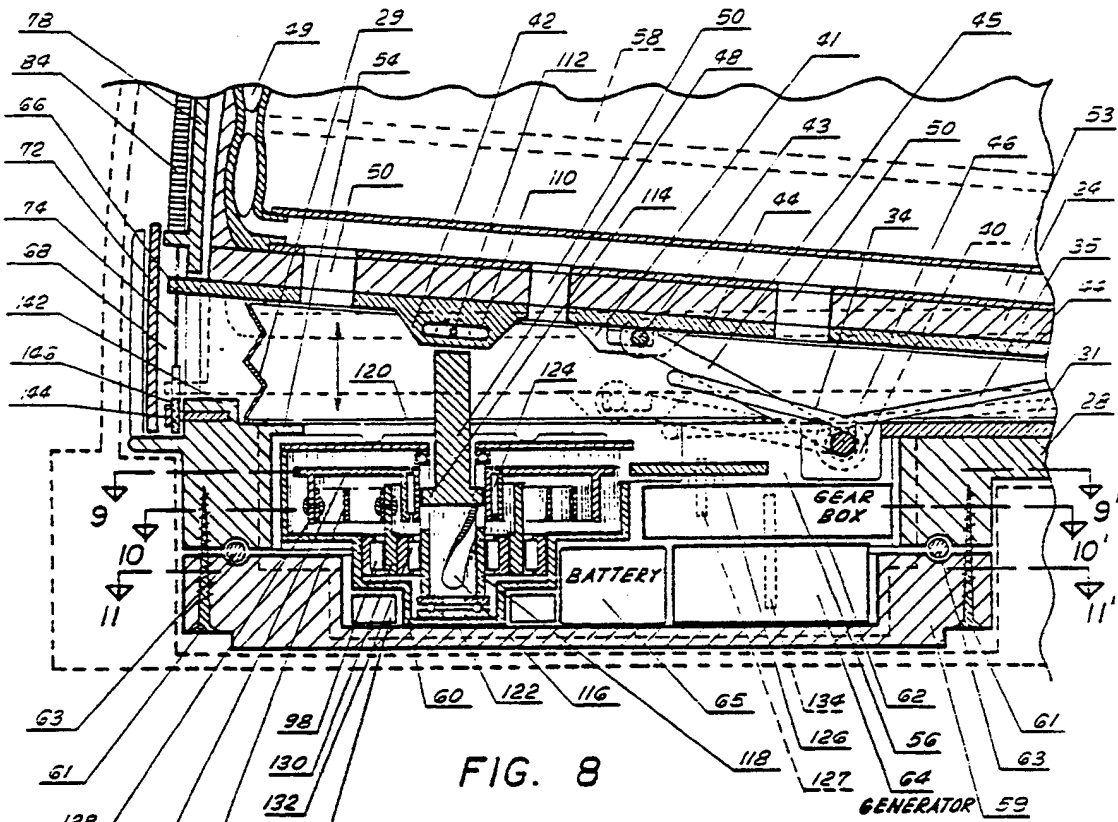

FIG. 8

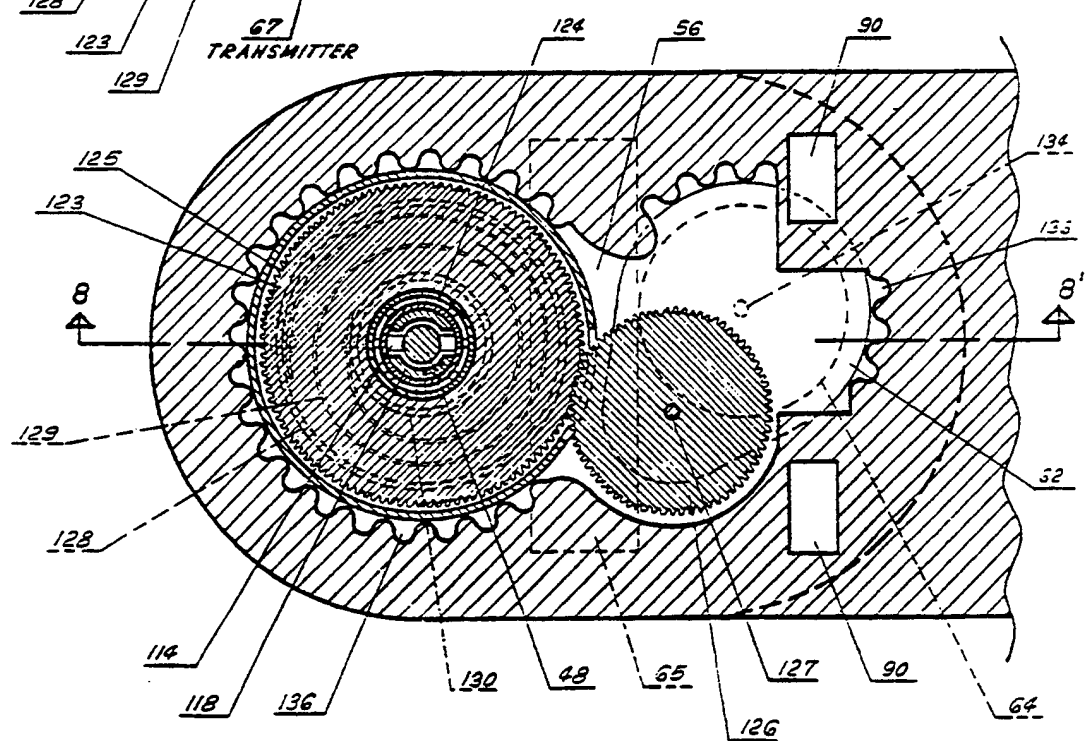

FIG. 9

# Advancing the State of the Art

- efficient, reliable, adaptable
- minimum perceived effort
- variable frequency and duty cycle
- diverse load requirements
- adverse environmental conditions

- targeted material selection
- design optimization through computer aided engineering
- microprocessor-based power management
- novel packaging and miniaturization technology
- compatiblize electronic and ergonomic constraints

A challenging synthesis of technologies and organizations against the backdrop of a microelectronics revolution



**“OVERVIEW OF DEVELOPMENTS IN SOUTH AFRICA”**

**(UNAVAILABLE)**

**Mr. Etienne Rijkheer**

**SYZYG  
Capetown, South Africa**



**LIST OF ATTENDEES**

## PROSPECTOR IX WORKSHOP ATTENDEES

BALLATO, Dr. Arthur  
Commander US Army, CECOM  
ATTN: AMSEL-RD/Art Ballato  
Ft. Monmouth, NJ 07703-5201  
Phone: 908-427-4308  
Fax: 732-427-3733

BENSEL, Dr. Caroline  
Science and Technology Directorate  
US Army Natick Research, Development  
and Engineering Center  
Natick, MA 01760-5020  
Phone: 508-233-4780  
Fax: 508-233-5104

BRANDHORST, Dr. Henry  
Space Power Institute  
231 Leach Science Center  
Auburn University, AL 36849  
Phone: 334-844-5899  
Fax: 334-844-5900

email: brandhh@mail.auburn.edu

BUEHLER, Mr. Martin  
Jet Propulsion Lab  
M/S 302/231  
4800 Oak Grove Drive  
Pasadena, CA 91109  
Phone: 818-354-4368  
Fax: 818-393-4663

BUSER, Mr. Rudolf G.  
Commander US Army, CECOM  
ATTN: AMSEL-RD/Rudy Buser  
Ft. Monmouth, NJ 07703-5201  
Phone: 908-427-4465  
Fax: 732-532-0749

CHASON, Mr. Marc K.  
Director, Motorola Energy Systems  
Automotive Energy And Components Sector  
4000 Commercial Avenue,  
Northbrook, IL 60062-1840  
Phone: 847-714-7406  
Fax: 847-714-7419

email: AMC002@email.mot.com

COOKMEYER, Dr. Donna  
U. S. Army Research Office  
PO Box 12211  
4300 S. Miami Blvd.  
Research Triangle Park, NC 27709-2211  
Phone: 919-549-4343  
Fax: 919-549-4310

email: Cookmeyer@aro-emhl.army.mil

DAVIES, Mr. Thomas L.  
NASA/JSC  
Mail Code EP5  
2101 NASA Road One  
Houston, TX 77058  
Phone: 281-483-9040  
Fax: 281-483-3096

DOLIGASKEI, Mr. Tom  
U. S. Army Research Office  
PO Box 12211  
4300 S. Miami Blvd.  
Research Triangle Park, NC 27709-2211  
Phone: 919-549-4251  
Fax: 919-549-4310

DOUGHTY, Dr. Daniel H.  
Sandia National Labs  
P.O. Box 5800, MS 0614  
Albuquerque, NM 87185  
Phone: 505-845-8105  
Fax: 505-844-6972

email: dhough@sandia.gov

FEDKIW, Mr. Peter S.  
U. S. Army Research Office  
PO Box 12211  
4300 S. Miami Blvd.  
Research Triangle Park, NC 27709-2211  
Phone: 919-515-3572  
Fax: 919-515-3465

FRY, Mr. Dwayne N.  
Oak Ridge National Laboratory  
P.O. Box 2008  
Oak Ridge, TN 37831-6009  
Phone: 423-574-5565  
Fax: 423-576-8380

GLICKMAN-WEISS, Dr. Ellen L.  
Kent State University  
SELS  
Room 163 MACCA  
Kent, OH 44242  
Phone: 330-672-2857  
Fax: 330-672-4106

email: wglickma@kentvm-kent.edu

GOODWIN-JOHANSSON, Dr. Scott H.  
MCNC  
PO Box 12889  
Research Triangle Park, NC 27709  
Phone: 919-248-1964  
Fax: 919-248-1455

email: goodwin@mcnc.org

GAUTAM, Mr. Gauba  
Arthur D. Little  
20/405, Acorn Park  
Cambridge, MA 02140  
Phone: 617-498-6639  
Fax: 617-498-7054

email: gauba.gautam@adlittle.com

HENDRICKSON, Ms. Mary A.  
Commander US Army, CECOM  
ATTN: AMSRL-EP-E  
Ft. Monmouth, NJ 07703  
Phone: 732-427-4978  
Fax: 732-427-3665

HUTCHINSON, Mr. John  
Baygen Power  
Ground Floor, Alphen Park  
Constanta Main Road  
Constanta, South Africa 7800  
Phone: 27-21-794-4888  
Fax: 27-21-794-4848

KORNBLUH, Mr. Roy D.  
SRI International  
333 Ravenswood Avenue  
Menlo Park, CA 94025  
Phone: 650-859-2527  
Fax: 650-859-5510

KRUGER, Dr. Jack  
U. S. Army Research Office  
PO Box 12211  
4300 S. Miami Blvd.  
Research Triangle Park, NC 27709-2211  
Phone: 919-549-4323  
Fax: 919-549-4248

LEBAU, Mr. Gerald M.  
TMC Inc/Baygen Power  
108 Westlake Drive  
Valhalla, NY 10595  
Phone: 914-328-5745  
Fax: 914-949-3909

LEVINSON, Dr. Lionel M.  
General Electric Corporate R&D  
One Research Circle  
Schenectady, NY 12309  
Phone: 518-387-6332  
Fax: 518-387-6204

LIN, Dr. Stephen F.  
Office of Research & Development  
3116 Annandale Road  
Durham, NC 27705  
Phone: 919-560-6463  
Fax: 919-560-5135

MARTIN, Mr. John H.  
ATTN: AMSRL-HR-ML, CECOM Field Element  
US Army Research Laboratory  
Human Research and Engineering Directorate  
Ft. Monmouth, NJ 07703  
Phone: 732-427-4866  
Fax: 732-427-3184

MATSUZAWA, Mr. Kinya  
Seiko Epson Corporation  
3-3-5 Owa Suwa-shi  
Nagano-ken, 392, JAPAN  
Phone: 81-266-52-3642  
Fax: 81-266-52-8065

MAYER, Dr. George  
US Army Research Office Ballston  
4015 Wilson Boulevard, Suite 216  
Arlington, VA 22203-1939  
Phone: 703-696-2529  
Fax: 703-696-2535

MERRYMAN, Dr. Steve  
Space Power Institute  
231 Leach Science Center  
Auburn University, AL 36849  
Phone: 334-844-5998  
Fax: 334-844-5900

email: [merryman@eng.auburn.edu](mailto:merryman@eng.auburn.edu)

MILLER, Mr. Michael R.  
U.S. Special Operations Command  
7701 Tampa Point Boulevard  
MacDill AFB, FL 33706  
Phone: 813-828-9635  
Fax: 813-828-9382

NEELY, Dr. William C.  
Space Power Institute  
231 Leach Center  
Auburn University, AL 36849  
Phone: 334-844-5905  
Fax: 334-844-5900

email: neelywc@mail.auburn.edu

NOWAK, Dr. Robert J.  
DARPA/DSO  
3701 North Fairfax Drive  
Arlington, VA 22203-1714  
Phone: 703-696-7491  
Fax: 703-696-9780

email: rnowak@darpa.mil

O'BRIEN, Robert  
US Army Soldier Systems Command  
Kansas Street, Code SSCNC-IW  
Natick, MA 01760  
Phone: 508-233-5813

PARADISO, Dr. Joseph A.  
MIT Media Lab  
20 Ames Street, Els-410  
Cambridge, MA 02139  
Phone: 617-253-8988  
Fax: 617-258-7168

PAUR, Dr. Richard  
U. S. Army Research Office  
PO Box 12211  
4300 S. Miami Blvd.  
Research Triangle Park, NC 27709-2211  
Phone: 919-549-4208  
Fax: 919-549-4310

RAINERI, Mr. Sal C.  
U.S. Army Special Operations Command  
Ft. Bragg, NC 28307  
Phone:  
Fax: 910-432-7964

RIJKHEER, Mr. Etienne  
SYZYAY  
P.O. Box 414, Eppindust  
Capetown, South Africa  
Phone: 27-21-531-3230  
Fax: 27-21-531-7079

ROSE, Dr. M. Frank  
Space Power Institute  
231 Leach Science Center  
Auburn University, AL 36849  
Phone: 334-844-5894  
Fax: 334-844-5900

email: rosemil@mail.auburn.edu

SAKA, Mr. Masakatsu  
Epson Research & Development Inc.  
225 Baypointe Parkway  
San Jose, CA 95134  
Phone: 408-952-6013  
Fax: 408-952-6147

email: saka@smos.com

SIEWIOREK, Dr. Daniel P., Director  
Carnegie Mellon University - ICES  
Hamburg Hall Rm 1201  
Carnegie Mellon University  
Pittsburgh, PA 15213-3890  
Phone: 412-268-5228  
Fax: 412-268-5229

SOVIE, Mr. Ronald J.  
NASA Lewis Research Center  
MS 301-3  
21000 Brookpark Road  
Cleveland, OH 44135  
Phone: 216-433-6129  
Fax: 216-433-2306

STEDMAN, Mr. Jay  
IDA Consultant  
10 Harvest Lane  
Glatsonbury, CT 06033  
Phone: 860-657-9134  
Fax: same

STEPHANS, Mr. James E.  
CECOM Environmental Systems Br.  
404 Fairground Road  
Front Royal, VA 22630  
Phone: 703-704-2006  
Fax: 703-704-2005

SURAMPUDI, Dr. Rao  
Jet Propulsion Laboratory  
MS 277-207  
4800 Oak Grove Drive  
Pasadena, CA 91109  
Phone: 818-354-0352  
Fax: 818-393-6951

TIEMANN, Dr. Jerome J.  
General Electric Corporation R/D Center  
P.O. Box 8  
Schenectady, NY 12301  
Phone: 518-387-7523  
Fax: 518-387-5299

TKACZYK, Dr. J. Eric  
General Electric CRD  
P.O. Box 8 Bldg KWC-1432  
Schenectady, NY 12301  
Phone: 518-387-5004  
Fax: 518-387-6030

TOOMEY, Mr. Kevin P.  
Charles Stark Draper Laboratory  
555 Technology Square  
Cambridge, MA 02139  
Phone: 617-258-2965  
Fax: 617-258-2942

WAGNER, Mr. Anthony P.  
NASA JSC, MC EC5  
2101 NASA Road One  
Houston, TX 77058  
Phone: 281-483-3485  
Fax: 281-483-9167

WYATT, Mr. Randall D.  
GE - Corporate Research  
1 Research Circle  
Niskayuna, NY 12309  
Phone: 518-387-5281  
Fax: 518-387-5449

ZEE, Dr. Ralph  
Materials Research and Education Center  
202 Ross Hall  
Auburn University, AL 36849  
Phone: 334-844-3320  
Fax: 334-844-3400