

141072

JPRS-CEN-88-003

25 APRIL 1988



**FOREIGN
BROADCAST
INFORMATION
SERVICE**

JPRS Report

DTIC QUALITY INSPECTED 6
Approved for public release;
Distribution Unlimited

Science & Technology

China: Energy

19980610 010

REPRODUCED BY
U.S. DEPARTMENT OF COMMERCE
NATIONAL TECHNICAL
INFORMATION SERVICE
SPRINGFIELD, VA 22161

DTIC QUALITY INSPECTED 6

10
69
A04

25 APRIL 1988

SCIENCE & TECHNOLOGY

CHINA: ENERGY

CONTENTS

NATIONAL DEVELOPMENTS

State Council Approves New Power Construction Funding
(YUNNAN RIBAO, 31 Dec 87).....1

HYDROPOWER

Development of Huang He Crucial to Growth of Northwest
(Yang Xinhe; LIAOWANG, 21 Dec 87).....3

Briefs
Work Proceeds on Geheyan 8

COAL

Tiefu: China's Newest Coal Base
(Yu Libo; SHIJIE MEITAN JISHU, Nov 87).....9

Nation Aims at Higher Coal Exports
(XINHUA, 27 Feb 88).....13

Briefs
Coal Output Up in Jan, Feb 15

OIL, GAS

Reorganization Urged To Achieve Breakthroughs in Oil, Gas
Exploration
(Xia Guozhi; ZHONGGUO DIZHI, 13 Jan 88).....16

Big Breakthrough in Offshore Oil Prospecting Reported
(Fu Pingping; RENMIN RIBAO, 1 Feb 88).....23

Nansha Islands Said Rich in Oil, Gas Reserves
(Yang Chunnan; RENMIN RIBAO, 18 Nov 87).....25

Jiangsu Field Now Producing More Than Yumen
(Gu Longyou; WEN HUI BAO, 30 Oct 87).....26

Biggest Offshore Oil Field To Date Reported
(Man Xuejie; RENMIN RIBAO, 9 Dec 87).....28

Aeromagnetic Anomalies, Paleozoic Hydrocarbon Potential of Lower
Yangzi
(Li Zhankui, Li Jianguo; SHIYOU YU TIANRANQI DIZHI, Sep 87..30

Water Injection at Daqing Proves Costly
(XINHUA, 21 Feb 88).....41

NUCLEAR POWER

Design of Nuclear Heat, Power Co-Generation Plant Detailed
(Liu Jukui; HE DONGLI GONGCHENG, Dec 87).....42

Daya Bay Said on Schedule for Completion in 1992
(Zhao Yuanguang; ZHONGGUO TONGXUN SHE, 9 Mar 88).....62

Preparations Underway To Install Equipment at Qinshan
(XINHUA, 26 Feb 88).....64

State Council Approves New Power Construction Funding

40130048 Kunming YUNNAN RIBAO in Chinese 31 Dec 87 p 1

[Article by Xinhua News Agency: "State Council Approves Levying Temporary Power Construction Fund"]

[Text] The State Council has approved a regulation submitted by the State Planning Commission entitled "Provisional Regulations on the Collection of Power Construction Funds." Every level of government is required to grasp the details as they are implemented. The collection work must be done seriously and the power construction fund must be well controlled and managed.

In order to solve the problem of serious shortage of electric power and lack of power construction capital, the State Council has approved the collection of a power construction fund which will be used as the working capital for power construction at the local level. The power construction fund will be collected in all provinces, autonomous regions, and municipalities under the direct jurisdiction of the central government. A power construction fund will be levied on all industrial power users (including foreign-owned and joint-venture businesses). The rate is 0.02 yuan per kilowatt and it is to be paid along with the electric bill. The fund will be collected by provinces, autonomous regions, and municipalities under direct jurisdiction of the central government. It will not be collected again by lower levels of government.

The regulation requires that the fund be deposited in a special account for specific uses. The power construction plan will be handled by the Ministry of Water Resources and Electric Power. In the last 3 years of the "Seventh 5-Year Plan," the power construction fund must be spent on major power construction projects listed in the national plan to supplement the capital shortfall.

Ownership of projects constructed with this fund (including associated distribution networks) must be given to the local government proportionally. Both power and profits must be distributed accordingly. Power distributed to the local government will be consumed by local

regulation published by the government. The principal, interest, and profit should be reinvested in power construction.

Every business is required to lower costs to absorb the power construction fund. Local governments may submit a proposal to the MWREP to request a reduction or waiver for the power construction fund for industries producing energy-intensive products, for businesses that lose money due to government policy, and in areas where electric power is abundant based on regional power balance, power demand, and ability of the industry to afford it. It is to be approved by the State Planning Commission and the Ministry of Finance. Electricity supplied by power plants owned by the business itself is exempt from this fund. The power construction fund is not taxable.

This regulation will be in effect from 1 January 1988 until 31 December 1995.

12553/9365

Development of Huang He Crucial to Growth of Northwest

40130035 Beijing LIAOWANG [OUTLOOK WEEKLY] in Chinese No 51, 21 Dec 87
pp 13-14

[Article by Yang Xinhe [2876 2450 3109]: "Huang He Water Brings Life to Northwest Economy"]

[Excerpts] On 5 October 1987, the Longyangxia Power Station, located on the Huang He below Chana Shan on the Qinghai Plateau, went on-line and began generating power. From that moment, the Huang He was captured by the 60-story high dam at the Longyangxia Gorge reservoir and the massive turbines in the generating units began converting Huang He hydropower into electricity fed into the 11,000-km-long ultrahigh voltage lines of the Northwest Power Grid and on to distant regions, the 1,000-li-long Hexi Corridor, and 800-li-long Qin Chuan in Ningxia and Shaanxi.

I. Several New Industrial Base Areas Arise

Today, development of Huang He hydropower has turned the northwest into China's only power-rich region. When all of the Longyangxia Hydropower Station project is completed, the amount of power generated in 1 year will be 1.7 billion kWh--more than all the power generated in China before 1949.

With cheap and abundant electric power, the textile, electronics, petrochemical, and other industries in the northwest will develop rapidly. A 5-kilometer-long "textile city" has appeared in the northwestern city of Xi'an. With five large modern textile enterprises here as a backbone, Xi'an now has 72 large and medium-sized textile mills and two large printing and dyeing mills. They form the largest textile industry system in northwest China and the gross value of output in the textile industry now accounts for 25 percent of the value of industrial output in Xi'an. In the western suburbs of Xi'an there is a new type of plant and scientific research unit producing high voltage and ultrahigh voltage power transmission and transforming equipment. China's huge transformer, with a maximum capacity of 360,000 kV, was developed here. China's largest civilian aircraft manufacturing company is located in the northern suburbs of Xi'an, and the first supersonic passenger jet and large cargo plane built by the Chinese people took off from here in the 1980's.

Lanzhou City in Gansu Province is a key northwest city. In 1949, it had only a few handicraft workshops making soap. Today, Lanzhou has become the northwest's chemical industry city, particularly in the petrochemical industry. The Lanzhou Chemical Industry Company, one of China's largest integrated petrochemical enterprises, was built here.

The first machine industry in Gansu Province, today's Lanzhou Universal Machine Works, originally was a "Foreign Artillery Bureau" run by the Qing government in Lanzhou. It now has grown into a large machinery plant capable of producing a variety of petroleum machinery, and it works in conjunction with the newly built Lanzhou Petrochemical machinery plant to produce petroleum drilling rigs and oil refining equipment as well as various types of oil extraction equipment for well cementation, well repair, fracturing, lifting oil, and so on, and their products are being sold worldwide.

Electric power has enabled Qinghai and Ningxia to build several large wool spinning enterprises. The Qinghai Wool Spinning Company makes woolen blankets, plush, wool-nylon blends and other products using the famous "Xining wool" as a raw material, and they are hot items on Chinese and foreign markets.

II. Large Energy-Consuming Enterprises Moving West

On the day of the hookup of the Longyangxia Power Station to the grid and power generation, Deputy Minister Lu Youmei [7120 0147 4168] of the Ministry of Water Resources and Electric Power told reporters that, before the 1970's, China's big energy-consuming enterprises were concentrated in north and northeast China. In recent years, north and northeast China have experienced power shortages while development of cascade power stations on the upper reaches of the Huang He has led to substantial growth in the power industry in northwest China. Moreover, hydropower is inexpensive, so major power-consuming enterprises are moving west one after another.

Statistics indicate that more than 80 large and medium-sized high energy-consuming enterprises in the nonferrous metals refining and processing, ferrous metals, chemical industrial construction materials, and other industries have been built in northwest China. These enterprises consume more than 15 billion kWh of electric power each year, which is equivalent to the power generated in more than 2 years' time by the Liujiaxia Power Station.

China's biggest electrolytic aluminum plant is being built in the northwest in Tiantong County, Qinghai Province. The civil engineering for the 1-kilometer-long electrolysis shop has been completed and equipment installation is being speeded up. When the second generator at the Longyangxia Power Station joins the grid before the end of 1987, 60 electrolysis troughs at this enterprise will be placed into operation. The design scale of this plant is for annual production of 200,000 tons of

aluminum nails; the annual power use load will be 400,000 kW. Its construction is being synchronized with Longyangxia Power Station which will have an installed capacity of 1.28 million kW.

The China Nonferrous Metals Industry Corporation plans to increase electrolytic aluminum production in China from its present base to 1.2 million tons a year by 1990. This newly added production capacity will be concentrated primarily in northwest China, which has abundant hydropower resources. The state also made plans recently to build a large aluminum mill in Weinan County, Shaanxi Province which will produce 100,000 tons of electrolytic aluminum annually. Preparations to begin construction are underway.

Northwest China is famous for its rich mineral resources. The Jinchuan mineral zone in Gansu Province's Hexi Corridor, one of China's three largest paragenetic mines, is an example. The variety of useful rare metals is seldom seen in the world. Other examples include the Changba Lead and Zinc Mine at the western tip of Qinling, the Xitie Shan mineral zone in Qinghai Province's Qaidam Basin, the iron ore at Helan Shan in Ningxia, and so on. All of them have extremely important status throughout China. The extraction and refining of these minerals must await increased power supplies.

Huang He hydropower utilization has accelerated mineral development in the northwest and aided its industrial economy. The resource advantages of Gansu Province, which historically has been rather impoverished, will be converted quickly into economic advantages when the three big Huang He hydropower stations at Liujiaxia, Yanguoxia, and Bapanxia are completed. Gansu Province now has over 30 nonferrous mineral refining enterprises and mines with over 200,000 employees. Income from high power-consuming enterprises in the nonferrous metals and other industries is important to national economic income in Gansu Province. Gansu Province now has five big high energy-consuming production systems for refining electrolytic copper, electrolytic nickel, electrolytic aluminum, rare earths, and lead and zinc, and they hold first place in China in output.

The Jinchuan Nonferrous Metals Company and Baiyin Nonferrous Metals Company are being built in synchronization with the Longyangxia Power Station, which has become an important electrolytic nickel and electrolytic copper producing area. Jinchang city, located in the Hexi Corridor, is known now as China's "Nickel Capital." Its mineral reserves and grades are second among world minerals of equivalent rank. The area produces electrolytic nickel and over ten additional product systems like gold, silver, platinum, rhodium, and so on. The state is investing 1.3 billion yuan to expand this enterprise.

The Qingtongxia Aluminum Mill being built in conjunction with the Qingtongxia Hydropower Station on the trunk of the Huang He also is undergoing large-scale expansion. Each year, the enterprise produces 32,000 tons of aluminum nails and uses 500 million kWh of electric power,

which still is less than half the power generated by the Qingtongxia Hydropower Station each year. To make full use of the cheap power from Qingtongxia, the state will invest 240 million yuan to import equipment from Japan to expand this enterprise. When it is finished, the annual production capacity of the electrolytic aluminum plant will increase to 80,000 tons.

III. Deserts Become "Jiangnans"*

The northwest now has more than 620 large-scale electrically powered lifting and irrigation stations capable of irrigating more than 10,000 mu each, and they are complemented by over 3,000 small lifting and irrigation stations. They bring water from the deep gorges of the Huang He to the high arid plains at elevations of several tens to more than 100 m to irrigate over 50 million mu of dry land.

Jingtai Chuan, located on the edge of Tenger Shamo, is a region of flat terrain and rich soil, but the extremely sparse precipitation and arid climate have prohibited cropping on more than 1 million mu of flat land. With electric power, Jingtai Chuan built an electric powered lifting and irrigation project with a lift of 446 m and a flow rate of 10 m³/sec. Water is lifted through 13 stages by 14 electric pumps to bring Huang He water to the ancient barren plain. Now, the water flows freely on Jingtai Chuan and there are rows of fields. The barren, frozen, and desolate vista of the past is no longer visible, and Jingtai Chuan has become a rich rice producing area.

Xihaigu region in Ningxia, one of the poorest areas of China, used Huang He hydropower to build the Guhai Electric-Powered Water Lifting Project a few years ago. People who have lived for generations on the arid loess now are planting crops on irrigated land and using running water for the first time in history.

While visiting the northwest, this reporter visited the eastern part of the Guangzhong region of Shaanxi Province on the trunk of the Huang He, where another large electric-powered water lifting and irrigation project is being built. This project will lift water from the Huang He and has a design flow rate of 120 m³/sec. The main canal will run for more than 90 km from Longmen southward along the west bank of the Huang He. Seven water drawing regions have been established along the canal which will use 70 electric-powered water lifting machines to send water to the 360 m high Weibei Plateau. When all of the project is completed, the area covered by electric-powered lifting and irrigation could reach 3.2 million mu.

*["South of the River," refers to the lush and prosperous region south of the Chang Jiang.]

IV. Huang He Hydropower Awaits Development

Starting in the 1950's, China has spent more than 30 years in arduous struggle and has invested more than 3 billion yuan to build six large key water conservancy projects on the upper reaches of the trunk of the Huang He at Longyangxia, Liujiaxia, and other sites. Now, the amount of power generated by hydropower stations on the upper reaches of the Huang He accounts for over one-half of yearly power output in the Northwest China Grid.

This is just the beginning of the prosperity which the Huang He will bring to the people of northwest China. According to surveys by the Ministry of Water Resources and Electric Power, 15 cascade power stations with an installed generating capacity of more than 13 million kW can be built on the upper reaches of the Huang He. Construction now is underway on another large power station below Longyangxia--the Liujiaxia Power Station--and the remaining stations will be completed before the end of this century. At that time, the Huang He will provide many times more power for the people of northwest China than it does now, and the pace of construction of modern civilization in the northwest will be speeded up greatly.

12539/9365

BRIEFS

WORK PROCEEDS ON GEHEYAN--Wuhan, 15 Dec--Full-scale construction work has now begun on the Geheyang key water conservancy project located on the Qing Jiang in the western mountains of Hubei Province. Using the latest in science and technology and the best of foreign experience, the core of the project--the Geheyang Hydroelectric Power Station--will be a showcase effort for the rest of the country. The Geheyang power station is the first major key water conservancy project to be attempted on the mainstream of the Qing Jiang. Of major importance on the State's construction agenda, the project is scheduled for completion in 1993. [Summary] [40130058 Shanghai WEN HUI BAO in Chinese 16 Dec 87 p 1] /9365

Tiefa: China's Newest Coal Base

40130032 Beijing SHIJIE MEITAN JISHU [WORLD COAL TECHNOLOGY] in Chinese
No 11, Nov 87 pp 3-5

[Article by Yu Libo [0060 4539 3134] of the Tiefa Mining Bureau: "Tiefa Mining Area: China's Newest Coal Base"]

[Excerpts] I. The Mining Area

Tiefa Mining Bureau is a large joint enterprise for coal production run by the Ministry of Coal Industry and the Northeast China-Nei Monggol Joint Coal Industry Company. Its coal reserves account for one-third of all reserves in Liaoning Province, and it has the largest reserves of any mining area in the province. The bureau produced 4.93 million tons of coal, had 98 million yuan in gross value of industrial output, and completed 133 million yuan of capital construction investments in 19867.

The Tiefa mining area is located in northern Liaoning Province between Tieling City, Tieling County, Faku County, Kangping county, and Tiefa City. The mining bureau offices are at Tiaobing Shan in Tiefa City. The bureau has 19 county-level units. It has under its jurisdiction six producing mines (Daming No 1, Daming No 2, Xiaoming, Dalong, Xiaonan, and Xiaoqing Mines), four engineering offices (two mine construction engineering offices and two civil engineering offices), three auxiliary production plants (central electrical equipment plant, water heating plant, and rock extraction plant), two departments (transportation department and power supply department), two offices (forestry office and education office), two schools (employee education school and technical school), a bureau Comprehensive Development Corporation, a central bureau hospital, and the Tiefa Mine Workers Press Agency, which basically form a rather complete large-scale coal industry enterprise.

The mining area as a whole includes the Tiefa, Kangping, and Kangbei Coal Fields which have a total coal-bearing area of 618.43 km². The mining area does not just have large coal reserves. In addition, its reserves are concentrated, mineshafts are concentrated, and subsidiary enterprises also are quite near the mine, which make development and management easier. The coal quality trademarks are mainly long-flame coal and secondarily gas

coal. Its coal has moderate ash, low sulfur, and low phosphorus contents, and the caloric value of the long-flame coal is 5,469 kilocalories/kg. The mining area is located near Shenyang, Anshan, Fushun, and other large industrial cities. Its main coal consumer, the Qinghe Power Plant, is 55 km away and it is only 8 km from the Qinghe No 2 Power Plant slated for construction. Coal marketing and out-shipment, as well as raw materials in-shipment, are very convenient.

II. The Course of Development

After the Third Plenum of the 11th CPC Central Committee, the Xiaonan and Xiaoqing Mines went into operation with substantial aid and assistance from the Ministry of Coal Industry, the Liaoning Provincial CPC Committee, the Liaoning Provincial Government, the Liaoning Coal Industry Management Bureau, and the Northeast China-Nei Monggol Joint Coal Industry Company. To speed up expansion of production capacity in the mining area and adapt to the needs of the national economy, the Tiefu Mining Bureau formulated a plan in early 1982 for increasing yearly output in five existing producing mines by 500,000 tons a year over 4 years. All bureau employees worked together to exploit potential, focus on transformation of mining technologies, greatly expand mechanization, and achieve a preliminary transformation of the passive production situation. From a base output level of 2 million tons/year in the mining area, it grew by 600,000 tons/year. It reached 4,554,500 tons in 1985, completing predicted increased output goals ahead of schedule. Output doubled in just 4 years and the situation of fluctuating coal output ended.

In early 1986, Comrade Yu Hong'en [0060 3163 1869], minister of the Ministry of Coal Industry, inspected the Tiefu mining area and fully confirmed that the Tiefu mining area had actually doubled coal output. He also issued even higher demands to accelerate development during the Seventh 5-Year Plan.

III. The Equipment Situation

Extraction involves comprehensive mechanization. The degree of mechanization in coal extraction was 53.27 percent in 1986, including 52 percent via comprehensive extraction. The use of Chinese-made coal extractors and hydraulic supports was combined with importation of coal extractors and hydraulic supports from the Soviet Union and Poland which were used for coal seams of medium thickness and some thin coal seams. To assure smooth progress in comprehensive extraction mechanization, tunnelers were imported from Japan and Australia. This led to stable and rapid growth in coal output.

A pillarless method of coal extraction which involved following cavities and leaving tunnels was adopted for high-gas coal seams of medium thickness prone to spontaneous combustion. This new technology was included among major industrial trial projects by the State Planning Commission. After testing and implementation at the Xiaonan Mine, these preliminary achievements were

made: 1) Recovery rates were improved, which permitted the recovery of an additional 200,000 tons of coal from just eight belts in a single mining area, which raised the recovery rate by 9.8 percent. 2) The amount of tunneling was reduced, and following cavities and leaving tunnels permitted dual use of tunnels. Dual use of a single tunnel can reduce recovery tunneling rates by 25 percent. This means that 700 m less of tunneling was required, so six fewer tunnels totalling 4,200 m long were needed in the mining area as a whole. 3) Following cavities and leaving tunnels changed the traditional relationship between extraction and leveling when tunneling two passageways. This permitted realization of continuous penetration shuttle recovery, facilitated centralization of production, reduced the time required to move working faces, raised the comprehensive material utilization rate, and improved economic performance in the mine as a whole. In 1986, the Ministry of Coal Industry, the Academy of Coal Science Research, Chongqing University, and other [units] convened a technical examination and acceptance conference at Xiaonan Mine in the Tiefu mining area and fully confirmed the technical accomplishment of pillarless cavity-following tunnel retention.

The "KJ-4 Microcomputer Mining Safety Production Monitoring System" was adopted. This system was based on some improvements in the FEMCO Coal Mine Safety Monitoring System imported from the NMS Company in the United States after it was digested, and it meets advanced international standards of the 1980's. This system handles real-time monitoring and processing of the underground environment, fires, ventilation facilities, transport safety conditions, and other information in coal mines. It is capable of emitting sound and light alarms and power cutoff control signals, and it provides forecasts and required handling of disastrous accidents. The Ministry of Coal Industry, Ministry of Aeronautics, and other relevant departments convened a technical examination and approval conference at Tiefu and affirmed this important technical achievement.

Rational centralization of production was achieved through reforms in the deployment of mineshaft openings and tunnel layout. To adapt to the needs of modernized production, conscientious analysis of the current situation in each of the bureau's mines led them to eliminate artificial boundaries contained in the original designs and re-draw mining areas. They increased the size of the mining areas and combined 84 mining areas in the original designs for six producing mines into 60, and they will combine 20 currently producing extraction areas into 16. After combination, the strike of the extraction areas will be increased from their original length of 400 to 600 m to 800 to 2,000 m. In addition, they deployed fewer rock tunnels and increased the deployment of coal tunnels, with extremely obvious economic results. One was a substantial reduction in the degree of tunneling; another was increased service lives of the extraction areas; a third was better adaptation to the needs of mechanized production. In addition, to improved unit output, they widely employed "counter-pull faces" and made full use of the advantages of "counter-pull faces," including long faces, high recovery rates, substantial dynamism, ease of centralization for production organization, and so on.

IV. Plans for the Seventh 5-Year Plan

Based on the demands made by the Ministry of Coal Industry, the bureau as a whole will depend mainly on exploitation of potential in old shafts during the Seventh 5-Year Plan to complete the overall plan for contractual responsibility during the Seventh 5-Year Plan. Coal output will exceed 8 million tons in 1990, and they will strive to put Daxing Mine into operation, which will increase annual coal output in the bureau to 10 million tons after it goes into normal production.

12539/9365

Nation Aims at Higher Coal Exports

40100012 Beijing XINHUA in English 1622 GMT 27 Feb 88

[Text] Beijing, February 27 (XINHUA)--China is aiming to increase its coal exports by 30 percent this year to 17 million tons, the general manager of the China National Coal Development Corporation said today.

Wei Guofu, speaking at the Third Pacific Rim Conference which ended today, said that last year China exported 13.13 million tons. While the exports only accounted for 1.5 percent of the country's total coal production of 920 million tons, they still earned \$464 million. The exports accounted for three to four percent of the world's total trade in coal.

Wei said that construction is being speeded up on railways and ports in order to boost coal exports.

The coal transport capacity of Shanxi Province, the major coal producer in the country, is expected to increase 25 percent by 1990.

The 200 foreign representatives attending the conference agreed that China's future in coal has never looked brighter. Dr Guy Doyle, a specialist on international coal/energy markets, said the export potential is bright because obstacles in transportation and port facilities are being removed. "China doesn't have strikes or other forms of labor unrest and its labor costs are low," he said, adding, "other coal exporters, like Australia and South Africa are shrinking away, leaving more opportunities for the Chinese."

Herman Van Ass, president of SSM Coal BV, Europe's biggest local trading company, said that China is "on its way to becoming a larger contributor to the international coal trade."

The three-day conference was sponsored by the China National Coal Import and Export Corporation, Double Resources Limited, Hong Kong and AER Enterprises of the United States.

Conference President Arnold H. Pelofsky, president of the AER Enterprises, said that by the year 2000, China and Colombia will control the coal markets in their respective hemispheres.

Some of the representatives at the conference, however, urged caution, saying that China should not expand its coal exports until it can satisfy its domestic coal demands.

/9365

BRIEFS

COAL OUTPUT UP IN JAN, FEB--Beijing, March 4 (XINHUA)--Chinese miners cut more than 133 million tons of coal in the first 2 months of this year, or an increase of 8.2 percent over the same period in 1987. Coal output for February alone was 59.14 million tons. According to an announcement from the Coal Industry Ministry, washed coal output during the past 2 months was 10.16 million tons, with total tunneling footage completed in the same period at 113,204 meters. [Text] [40100012 Beijing XINHUA in English 1112 GMT 4 Mar 88] /9365

Reorganization Urged To Achieve Breakthroughs in Oil, Gas Exploration

40130055 Beijing ZHONGGUO DIZHI [CHINA GEOLOGY], in Chinese No 1, 13 Jan 88
pp 3-6, 2

[Article by Xia Guozhi [1115 0948 3112]: "Realizing Major Breakthroughs in Oil and Gas Exploration"]

[Excerpts] After liberation, under the leadership of the party and through the combined efforts of concerned areas nationwide, China made great strides in petroleum and natural gas exploration, ensuring the rapid development of the petroleum industry. Today the situation in oil and gas exploration is good; however, it must be noted that reserves and reserve bases are inadequate and are still a key factor restricting a further development of the petroleum industry. To double petroleum production by the year 2000, petroleum reserves must grow at a great rate in the next 10 years; to improve the very low level of China's natural gas petroleum, natural gas exploration should advance even faster. To implement the strategic demand of accelerating the development of the energy industry and the great target of the initial stage of China's socialism proposed by the 13th Congress, a new situation must be created and great breakthroughs achieved in petroleum and natural gas geological work.

In the past few years, "second round" surveys have made encouraging progress. Important preliminary breakthroughs have been realized in the Tarim and the East China Sea, forming two key exploration areas, one in the west and one in the east. There have also been discoveries in such exploration regions as Sichuan, Song-Liao, Ordos, and the southern part of North China. During the Sixth 5-Year Plan, industrial oil and gas flows were obtained in dozens of wells. At the same time the principle of comprehensive search for deposits was carried out thoroughly and carbon dioxide deposits and salt mines with economic value were discovered. There have been general improvements in the degree of regional geological research. Important results have been achieved in methodological and technological attacks on southern carbonate rock regions and coal-forming geological research. There have been considerable improvements in technical equipment, some successful measures have been adopted in organization and management, there have been improvements in the quality of the ranks and reforms have been started. However, development is uneven,

some regions have not yet made breakthroughs; there have been "high yields without high income," and although there have been indications in the drilling process, oil and gas has not been obtained. Many difficulties and problems exist: funds are in short supply, the ranks are overstaffed, many links in equipment, and technology, and management are not suited to the demands of growth, economic benefits are not high and comprehensive research is weak. Although the leadership of some units has not yet been able to concentrate primary energies on geological exploration, after the Ministry convened a conference of bureau heads last year there have been improvements.

The oil and gas geology mission of mining departments in the Seventh 5-Year Plan is enormous. On the basis of regional survey evaluations, we should select favorable sections, carefully design and begin construction, and produce a group of discovered wells and controlled reserves; at the same time evaluation should continue to lay a further foundation for future work, and gradually realize the goal of the strategic mission of the "second round" surveys. Sedimentary rock is widely distributed in China and, based on scientific predictions, petroleum and natural gas resources are abundant, but proven reserves account for only a very small part of them. The degree of exploration in many regions is low or work is only just beginning. The key problem now is that thinking should be unified, understanding improved, confidence strengthened, main targets clearly identified, careful deployment arranged, reform intensified, management strengthened, level of technology improved, funds used sensibly, joint and cooperative work expanded, the glorious tradition of dedicated struggle developed, and major breakthroughs effectively organized. If we can achieve this, then the mission of the Seventh 5-Year Plan can be completed.

I. Redeploy, Pinpoint Breakthrough Directions and Goals

On the basis of results of the past few years, a redeployment based on seeking truth from facts is the foundation for realizing important breakthroughs. A major distinction between the mission of the Seventh 5-Year Plan and the Sixth 5-Year Plan lies in the need to discover new wells and reserves. Under conditions where money is tight, even more attention should be paid to economic benefits.

Apart from continuing to stress the two key areas east and west, natural gas exploration of southern Song-Liao, Sichuan, Ordos, and North China regions should be intensified, oil and gas exploration in northern Jiangsu should be further developed, the comprehensive research and methods attack on off-shore carbonate rock regions should be intensified, and drilling discovery wells should be secured.

Natural gas exploration should be given special consideration. Here the problem of accelerating development of coal-formed gas work is discussed in particular. During the Sixth 5-Year Plan, results of scientific research on evaluation of coal-formed gas resources affirmed that China's resources are very rich and this is an area which must be stressed. Comprehensive

exploration should be conducted, primarily for coal-formed gas but also for coal, oil, and other types of natural gas. The emphasis should be on finding large-scale gas deposits, but medium- and small-scale deposits, especially in economically developed regions or near cities should not be ignored. Developing these medium- and small-scale gas fields can secure large economic benefits. During the Seventh 5-Year Plan, evaluation and region selection should improve. The focus will be on clearly effective regions, prior exploratory work in promising areas and key regional development exploration, and testing and research to lay a solid foundation for the Eighth 5-Year Plan.

II. Relying on Scientific and Technological Progress, Improving Technology Levels

"Modern science and technology and modernized management are decisive factors in improving economic results and the mainstay for China's economy to move towards a new mature stage." The exploratory nature of oil and gas prospecting is intense and investment is large, and the regional conditions to be faced in the future become more complex daily, thus new major breakthroughs must rely on scientific and technological progress and strict observance of scientific oil and gas exploration work procedures. Geological theory, exploratory methods, and technological research should be strengthened promptly. We must correctly absorb, digest, and comprehensively apply domestic and foreign new theories, new thinking, new technologies, new methods, and new techniques in geological prospecting and constantly summarize our own experience to overcome difficulties in exploratory work and improve ability to resolve geological problems. Scientific research work should be effectively organized in accordance with key science and technology planning of the Seventh 5-Year Plan. The following key aspects should also be stressed:

1. Strengthen comprehensive research in exploration, promote close integration of science and technology with production

Oil and gas exploration is a process of searching for and ascertaining oil and gas fields on the basis of scientific theory in line with definite prospecting thinking and conceptions by staged and comprehensive application of various means and methods and is a process of constant practice and learning. Oil and gas prospecting is more expensive than exploration and development. Breakthroughs in knowledge and breakthroughs in results are closely linked and stressing research can guide work initiative. The current problem is that comprehensive research in surveying is weak and the gap between certain key science and technology research projects and actual work is large. In terms of one region, there is the problem that technological forces are inadequate or not used properly; in terms of the overall situation, it is mainly that overall advantages are not fully exploited. To improve this situation, the following work should be stressed now: 1) Identify the primary mission of each exploration unit's geological team as pursuing geological observation and research work in the survey process, and if forces are not organized

rationally they should be resolutely reorganized; 2) replenishing key region comprehensive research forces; 3) fully exploiting the initiative of existing talent; 4) fully exploiting the role of existing computers and improving data processing capability; 5) intensifying geological supervisory functions and improving management system for existing well-drilling geology teams so that well-drilling geology personnel can participate in comprehensive research activity; 6) chief engineers are responsible overall for professional technical leadership of exploration and scientific research; 7) develop the role of comprehensive research centers; 8) improve leadership of key scientific research work. Key topic groups should provide results by stages and promptly submit them to exploration units for use.

2. Maintain geophysical prospecting progress, fully and effectively develop the function of geophysical prospecting

In each stage of oil and gas exploration, geophysical prospecting methods should be appropriately used, the quality and results of geophysical prospecting work should be improved, the advance function of geophysical prospecting should be fully developed and the practice of not operating according to prospecting procedure and drilling recklessly should be resolutely stopped. The basic mission of geophysical prospecting is to research and evaluate comprehensively the structures, lithic nature and oil and gas of a basin in close combination with geology to identify prospective regions and rich regions and to provide a scientific basis for rational assignment of drilling. During the Seventh 5-Year Plan the topographical geological conditions of many prospecting areas are complex, the target strata very deep and due to gaps in technology, equipment, and management, the ability of geophysical prospecting to resolve problems is limited. In this regard we should stress improving seismic exploration technology as well as other geophysical prospecting methods and the comprehensive application of petrochemical prospecting to prevent concentrating on one thing only.

On the basis of past advances, seismic exploration should focus on the new situation and missions facing it and put its emphasis on the issue of improving the ability to solve geological problems under complex conditions, the issue of methods appropriate to calculating reserves, the issue of developing the specialized technology required by natural gas exploration, the issue of special handling of resources and the issue of comprehensive interpretation of geophysical prospecting results. Obtaining breakthroughs in these issues will greatly spur on major breakthroughs in oil and gas results. Scientific research planning should be conscientiously carried out, leadership should be strengthened, inspection should be supervised, organization should be coordinated, and results should be promoted.

Technical management of seismic prospecting should be done solidly, comprehensive quality control should be carried out on each project in accordance with the standard set forth by the ministry. Seismic personnel

whose work quality fails to meet stipulated demands will not be able to participate in mission contracts, and those whose quality is seriously substandard will suffer economic sanctions. The two key links of work planning and result reporting should be stressed thoroughly. Materials processing and interpretation should be organized thoroughly, and the cycle shortened and quality improved. In planning terms, materials processing expenses as a proportion of overall seismic work costs should be increased and method of materials processing fee recovery should be improved. All seismic cross-sections must be fully processed in line with norms and planning demands, otherwise the results report cannot be accepted. To insure quality, technical training should be improved, equipment should be improved, and adaptability should be strengthened.

By applying comprehensive geophysical and chemical prospecting methods, region evaluation and selection can be carried out faster and economically and can supplement the inadequacies of seismic methods in regions where seismic work conditions are poor, and new clues for oil and gas predictions and direct oil finds can be provided. Effective methods should be organized into packages and made a part of scientific exploration procedure. The prospecting unit of each region should formulate current and long-range comprehensive geophysical and chemical prospecting development plans. Before new projects are decided on, previous comprehensive geophysical and chemical prospecting materials should be systematically researched and a work plan presented. Relevant scientific research, training and nonseismic geophysical prospecting and petrochemical prospecting materials and interpretation should be improved.

Geophysical well-logging is an indispensable technique in exploring and developing oil and gas fields. In recent years, there have been advances in well-logging technology and equipment. However, well-logging is still a weak link and its ability to distinguish oil and gas-bearing strata of complex lithic nature, especially fracture-type oil and gas bearing strata, is still very poor and methods must be adopted to change this backward situation as quickly as possible.

3. Carrying out scientific well drilling, and develop sets of technology

Carrying out scientific well drilling, improving well-drilling success rate and shortening the well building cycle are important measures for realizing major breakthroughs in oil and gas exploration. Its primary goal of well drilling is to verify geophysical prospecting materials, establish a lithic cross-section, discover oil and gas deposits, and provide materials on the physical nature and oil production of oil and gas strata. Prospecting drilling is an important part of each geological construction project: it makes up the greatest proportion of investment and determines whether or not oil and gas exploration costs can be lowered. Thus we demand that drilling use the most advanced design and technology possible, carry out scientific organization and management, guarantee quality and safety and achieve the design norms of each project at the lowest cost. Since "second round" surveying, there have been improvements in well drilling, a group

of qualified wells have been drilled, important geological findings have been obtained, and some advanced units have emerged, but problems of "design backwardness, out-dated equipment, crude technology, and lax management" still exist to varying degrees in prospecting regions and this is not suited to the demands of obtaining major breakthroughs in oil and gas exploration where investment is rather tight. Accidents and problems with quality have appeared in many instances in well cementation, well-logging, and oil (gas) sampling and have become an important reason for "high yields without high income." To improve this situation rapidly, we should further promote scientific well drilling, develop processing technology packages, demand ensuring every well drilled, and while guaranteeing quality and safety, greatly improve efficiency, lower costs and obtain safe and accurate geological materials. At present, the following measures should be stressed: 1) summarize and promote the experience of advanced rigs and study the experience of fraternal departments; 2) promote the experience of cooperative drilling and prospecting work in the Ordos and Sichuan regions; 3) digest and absorb imported equipment better, accelerate the pace of improving old facilities and equipment and increase the utilization rate of equipment; 4) continue to stress such techniques as strata pressure prediction measurement, drilling mud, jet well drilling, and well control and, taking aim on advanced international levels, continue to develop new technologies; 5) improve technical training; 6) create standardized drilling crews; 7) establish solid norms and systems and carry them out strictly; 8) promote project contracts; and 9) uphold safe work.

Such weak links as well cementation, well logging and oil sampling should be thoroughly improved, the problems of equipment and technology resolved, and forces suitably concentrated.

III. Deepen Reform, Spur on Work

The 13th Congress stated that realization of economic development strategy should depend on reform, and reform is a driving force that spurs on all work. Development of geological work similarly relies on reform. To resolve problems of technological progress and improve the level of management, comprehensive reform of the existing system must be carried out.

Project management should be further intensified. Engineering professional contracts should be promoted and improved, and tenders should be invited when conditions permit developing in the direction of project contracts. Project contracting units should have full autonomy and responsibility, and rights, and benefits should be unified.

The geology market is an avenue and window for invigorating the economy, accumulating capital, exchange technology and broadening vistas. Through contract tasks abroad not only can economic benefits be obtained, but ranks can be trained and administrative ability improved. We should continue to exploit the advantages of oil and gas exploration ranks, do a good job of

market forecasting, formulate development plans, use talent sensibly, broaden the administrative realm, provide high quality service and consolidate and open up the geology market.

Developing diversified administration is a strategic task for readjusting industrial structure and rank structure, forming a crack geology corps, and spurring on development of geology work, and it must be given serious consideration. On the basis of the general strategic targets, we should carefully carry out project feasibility verification, select or invite administrative and management talent to set up an entity which manages on its own and is responsible for its own profit and loss. Promote contract administration and lease systems.

Consolidate and further develop small-scale oil and gas development bases. At the same time, stress reform of such items as planning, goods and materials, labor, personnel, and science and technology. Study how better to use economic leverage for regulation and control.

Continue to develop alliances and domestic and foreign cooperation.

Further expand opening up abroad, develop exchange and cooperation with foreign science and technology, import talent, technology and equipment, develop economic cooperation abroad, and open up the international market.

Leadership at all levels should encourage initiative and creativity and in the process of studying and implementing the documents of the 13th Congress summarize and thoroughly implement the spirit of the Ministry of Mining's work conference, guide the employees to overcome the influence of out-of-date, rigid thinking and old models, fully recognize the urgency and importance of reform, and fully recognize that realizing major breakthroughs is the basic mission of exploration ranks to reform the overall situation.

8226/9365

Big Breakthrough in Offshore Oil Prospecting Reported

40130048a Beijing RENMIN RIBAO (OVERSEAS EDITION) in Chinese 1 Feb 88 p 3

[Article by Fu Pingping [1381 5493 5493] released by Xinhua News Agency: "Major Breakthroughs in Offshore Oil Prospecting"]

[Text] Offshore oil prospecting reached a new plateau with three major breakthroughs in 1987, according to China Offshore Petroleum Corporation.

These major breakthroughs are the Liuhau 11-1 oil field at the mouth of the Pearl River in the South China Sea which is a joint venture, and the Suizhong 36-1 oil field in the Liaodong Bay of the Bohai Sea and the Wei 6-1 natural gas structure in the Beibu Bay.

Thick oil layers were found in all three wells drilled in the Liuhua 11-1 field. It was confirmed that it is of commercial value. Preliminary estimates indicate that the reserve may be more than 100 million tons. Geologists believe that this may become a "hot spot" in the South China Sea.

Seven wells in the Suizhong 36-1 field have produced in high capacity. A 22-km² area has been controlled. The geological reserve is over 100 million tons. It is reported that oil is abundant in the general surrounding area. More prospecting around the field is expected.

In the Wei 6-1 natural gas structure, high-capacity gas production was found in the first exploratory well. The gas layer is more than 100 m thick. Test results showed that it is possible to produce 940,000 m³ of natural gas, 211 m³ (150 tons) of condensate, and 236 m³ (195 tons) of crude oil daily.

In addition, three more oil-bearing structures were discovered in the South China Sea and the Bohai Sea.

Due to the progress made in oil and gas exploration, the offshore oil industry in China ended the era of prospecting alone. Since last year, prospecting and exploiting are done simultaneously. To date, seven oil fields are being constructed and four are in the feasibility study stage.

In 1987, China produced 710,000 tons of oil offshore and exported 500,000 tons of crude oil. Last year, China implemented some flexible measures, such as reducing the mining fee and improving investment return, to attract foreign capitals. Five prospecting agreements were signed with foreign corporations. In addition, the government also increased its investment in physical survey. More than 27,000 km of seismic survey was done last year. It was estimated that offshore oil production may reach 3 million tons in China by 1990.

12553/9365

Nansha Islands Said Rich in Oil, Gas Reserves

40130028a Beijing RENMIN RIBAO (OVERSEAS EDITION) in Chinese 18 Nov 87 p 1

[Article by Reporter Yang Chunnan [2799 2504 0589]: "A 40-Day Survey by 'Haiyang No 4' Shows Nansha Islands Rich in Oil and Gas Resources"]

[Text] The Ministry of Geology and Mineral Resources vessel "Haiyang 4" returned to Guangzhou on 16 November 1987 following a comprehensive offshore geophysical survey in the Nansha Islands.

The results of the survey indicate rich oil and gas resources in the waters around the Nansha Islands.

The survey took 40 days and traversed the South China Sea Basin. Scientific surveys of seismology, marine gravity, marine magnetism, depth soundings, and other aspects were carried out in the region over measurement lines more than 6,000 km long. A comprehensive and systematic survey also was made of Zengmu Ansha Basin, China's southernmost point.

According to the experts, there are relatively thick Mesozoic sediments which contain rich oil and gas resources over a large area of the continental shelf and continental slope around the islands. Preliminary outlines have been determined for eight large and medium-sized sedimentary basins covering a total of 350,000 km².

They discovered through a comprehensive and systematic measurement grid survey over an area of 180,000 km² of the Zengmu Ansha Basin that sedimentary strata in the basin average 4,700 m in thickness and may have a maximum thickness exceeding 8,500 m, which indicates that the region contains extremely rich prospective oil and gas resources.

12539/9365

Jiangsu Field Now Producing More Than Yumen

40130028b Shanghai WEN HUI BAO in Chinese 30 Oct 87 p 1

[Article by Reporter Gu Longyou [7357 7893 0645]: "Yearly Output at Jiangsu Oil Field Surpasses Yumen--Oil and Gas Reserves More Than Quadruple Those When First Built"]

[Text] Current oil and gas reserves in the Jiangsu Oil Field are more than quadruple the reserves when it was first built and yearly petroleum output there now exceeds output at the Yumen Oil Field.

The Jiangsu Oil Field lies within the Subei [Northern Jiangsu] Basin between a line from Jiangdu to Rugao on the south, Lianyungang on the north, a line from Sihong and Xuyi on the west, and up to the Yellow Sea on the east. On the basis of work done by geological departments during the 1950's and 1960's, the Ministry of Petroleum Industry transferred forces from each large oil field in China in 1975 to begin large-scale exploration and development of the Jiangsu Oil Field.

The Jiangsu Petroleum Prospecting Bureau began evaluating oil and gas prospects in each Lower Tertiary depression in Subei Basin in 1981, and they calculated the amount of oil generated and accumulated in each of the depressions. In addition, they also undertook a series of studies of each depression's strata, structures, oil generating rock, lithofacies and paleogeography, oil and gas pool formation conditions, geophysical methods, and other topics. Moreover, they made substantial efforts to popularize the use of new prospecting and development technologies and drilled large-displacement inclined wells and clustered test wells at advanced standards within China. After oil plays in the Fuminzhuang and Lianmengzhuang areas, they immediately went into development and continued to expand the oil-bearing area. As a result, reserves at this small oil field have increased by more than 10 million tons.

A preliminary scale has been attained now at the Jiangsu Oil Field. More than 400 wells have been drilled in the field and drilling exceeds 1 million m. There are almost 200 oil and gas wells of all types. From Shaobo to Zhenwu, and from Zhenwu to Fumin, tall buildings one after

another rise from the level ground and row upon row of drilling rigs stand like a forest in the countryside. It was learned that the Jiangsu Oil Field may have a yearly production capacity of 1 million tons by 1990.

12539/9365

Biggest Offshore Oil Field To Date Reported

40130028c Beijing RENMIN RIBAO (OVERSEAS EDITION) in Chinese 9 Dec 87 p 1

[Article by ZHONGGUO SHIYOU BAO [CHINA PETROLEUM REPORT] Reporter Man Xuejie [3341 1331 0267]: "China's Largest Oil Field to Date Discovered in Liaodong Bay--Suizhong No 36-1 Oil Field Controls Geological Petroleum Reserves Exceeding 100 Million Tons, Chinese-Run Offshore Oil Field With Yearly Output Over 1 Million Tons To Be Finished by 1990"]

[Text] Offshore petroleum experts in the China Bohai Sea Petroleum Company recently made the following evaluation: The Suizhong No 36-1 Oil Field discovered in Liaodong Bay in 1987 controls geological petroleum reserves of 140 million tons, making it the largest offshore oil field discovered in China to date.

After the discovery of a 100 m thick oil-bearing stratum in the Suizhong No 36-1 formation in June 1987, the Bohai Sea Petroleum Company dispatched a seismic vessel and drilling vessel for offshore work. In the past 6 months, they made seismic sample surveys and precise observations, and they drilled four evaluation wells and two exploratory wells, obtaining high output industrial oil flows in each of them.

After careful deliberations, the experts feel that this formation's petroliferous area may cover 22.5 km² and that the reserves it controls may exceed total reserves obtained during petroleum prospecting in the Bohai Sea over the past 20 years.

Bohai Sea Petroleum Company general manager Zeng De'an [2582 1795 1344] said that this major discovery not only eliminates the past situation in which only medium and small oil fields were discovered in the search for oil in Bohai Sea, but moreover that it increases the depth of and enriches our understanding of the laws of petroleum exploration and raises our confidence in continued discovery of large oil and gas fields in the Bohai Sea. He indicated that China is capable of independently exploring and developing offshore petroleum.

The China Offshore Petroleum Corporation sent a congratulatory telegram on 7 December 1987 which stated that this important discovery is another

indication of the bright prospects for petroleum development in the Bohai Sea.

The Bohai Sea Petroleum Company now is speeding up work in preparation for development of the Suizhong No 36-1 Oil Field. A Chinese-run offshore oil field producing more than 1 million tons of crude oil annually will be completed here by 1990.

12539/9365

Aeromagnetic Anomalies, Paleozoic Hydrocarbon Potential of Lower Yangzi

40130022 Jiangling SHIYOU YU TIANRANQI DIZHI [OIL AND GAS GEOLOGY] in Chinese Vol 8 No 3, Sep 87 pp 325-332

[Article by Li Zhankui [2621 0594 1145] and Li Jianguo [2621 1696 0948] of the Aerogeophysical Prospecting Headquarters, Ministry of Geology and Mineral Resources: "Aeromagnetic Anomalies and Paleozoic Oil and Gas Prospects in the Lower Yangzi Region"]

[Excerpts] [Abstract]

The results of a high-accuracy aeromagnetic survey indicate that the Lower Yangzi Paraplatform can be divided into three regions on the basis of magnetic field differences. From north to south, there are indications of Proterozoic Haizhou Group, Banxi Group, and Lengjiayi Group basements. In addition, it was determined that there are two fractures, the Tianchang-Dongtai and the Anqing-North Hangzhou Fractures, which have east-west strikes. They controlled basement properties, development of capping strata, magmatic activity, and the distribution of minerals. The oil and gas prospects of the Lower Paleozoic are best in the Nanjing-Nantong area, and second best in the Subei [northern Jiangsu] region. [End abstract]

In structural terms, the Lower Yangzi region is known as the "Lower Yangzi Paraplatform." It has capping strata sediments and thick and widespread strata conducive to oil and gas content. The oil and gas prospects of Mesozoic, Cenozoic, and Paleozoic carbonate rock have received attention from geologists over the years. To clarify basement undulations and geostructural features in the region, the Aerogeophysical Prospecting Headquarters did a high-accuracy (0.1 nT) aeromagnetic survey (in 1984) and obtained abundant geological information. This article will attempt to synthesize a large amount of geophysical achievements as a basis for suggesting some views on basement structures, structural features, and capping strata development conditions in the Lower Yangzi region, and for a preliminary analysis of Paleozoic oil and gas prospects.

I. Magnetic Field Characteristics

The aeromagnetic survey showed that the Lower Yangzi region has three different magnetic field situations. It showed that each of the partial magnetic fields have basement structure and capping strata development conditions which correspond to these main features:

(1) To the north of a line from Tianchang to Dongtai, there is a flat, low and gently-varying positive-negative magnetic field with an intensity of ± 50 nT. No local anomalies have developed. The basement encountered in outcrops and drilling in the region is mainly weakly-magnetic Haizhou Group (Jinping Group, Yuntai Group) schist and leptynite systems, so the negative magnetic field is interpreted as a basement structure region formed by the Proterozoic Haizhou Group. However, comparison of the rising positive magnetic field in the Sheyang-Yangcheng region with the magnetic field characteristics of outcrops of the Jiaodong Group (Qushan System) in the Ganyu, Donghai, Guanyun and other areas convinced us that this positive magnetic field region is an indication of the Lower Proterozoic Jiaodong Group basement. It and the Southern Yellow Sea Block form the core of the Subei-South Yellow Sea Basement Abyssal Basement, and they are important component parts of the South Yellow Sea Block.

(2) The magnetic field in the area south of a line from Tianchang to Dongtai and north of a line from Anqing to Hangzhou is a series of northeast-striking positive anomaly bands on a low and gentle negative background. Wells at Zhoupu, Songjiang, Jinshan, and other locations found the Middle Proterozoic crystallized basement at a depth of 300 m. Its lithography is similar to the Banxi Group. This suite of strata was measured as weakly magnetic. Thus, this low and gentle magnetic field background is an indication of a Middle Proterozoic basement structure region. The positive anomalies with a northeast strike indicate the presence of intense folding and magmatic activity within the basement.

(3) The region south of a line from Anqing to Hangzhou is a block-shaped and belt-shaped normal magnetic field region with broad and gentle rising variations. The intensity is 100 to 300 nT. The Banxi Group, which forms the Jiangnan Old Land, outcrops over a large area. It is weakly magnetic and incapable of generating such a strong magnetic field intensity. What sort of rock system, therefore, is indicated by these magnetic strata? We know that a "Jiangnan-type" basement has a dual-layer structure. The upper stratum is the Banxi Group and the lower stratum is the Lengjiaxii Group or Fanjingshan Group. These magnetic field features may be an indication of eugeosynclinal Lengjiaxii Group or Fanjingshan Group sediments similar to an early geosyncline. This would mean that it is a basement complex composed of volcanic-sedimentary formations, slow-source intrusive rock, rift-type migmatite and other things. The reasoning is that the Jiangnan Old Land, the Qiantang Fold Belt, and western regions all have dual-layer basement structure features.

This analysis indicates that there were two stages in the formation of the Lower Yangzi Paraplatform basement. Initially, during the Lengjiaxii and Fanjingshan periods, it was an eugeosyncline. Afterwards, it went through the first instance of folding during the Wulig (Dong'an) Movement, after which it was converted into a platform during the Xuefeng Movement.¹ Analysis of magnetic field features indicates that the Lengjiaxii Group and Fanjingshan Group stop at a line from Anqing to Ningguo to Nangzhou and do not extend further east.

(4) In the central and northern parts of the Lower Yangzi region, a series of northeast-striking linear anomaly bands were found in the magnetic field. Those with large peaks, steep gradient and obvious associated negative values (or superimposed on background field anomalies) generally are caused by Mesozoic basic, semi-basic, and semi-acidic rock bodies. On the other hand, magnetic anomalies with steep gradients and abrupt variations are indications of semi-basic and basic volcanic rock. The gentle short-axis magnetic anomalies have amplitudes from 10-plus to several 10 nT. Comparisons with surface geophysical prospecting data provide a preliminary confirmation that they are indications of basement uplifts (Figure 2).

(5) According to aeromagnetic features, the Lower Yangzi region contains a group of east-west striking fractures. This group of fractures has failed to attract attention. They have very obvious control over basement properties, capping strata accumulations, magmatic activity, and the distribution of minerals. They were formed later than fractures with a northeast strike. The two main ones are the Tianchang-Dongtai and the Anqing-North Hangzhou Fractures. Their primary commonalities are: 1) They form boundaries between different magnetic field regions (Figure 1). The two fractures divide the Lower Yangzi Paraplatform into three blocks with individual magnetic field characteristics. Magnetic field values in the southern and northern parts are higher and gentler, and no local anomalies developed. Magnetic field values in the central part obviously are lower, and northeast striking anomalies and anomaly belts developed. This indicates that there are differences in basement properties and magmatic activity among the three regions. 2) On gravity maps, the former appears as an anomaly zone with an east-west strike and the latter is a gravitational gradient zone with an east-west strike. Its gravitational field also shows three parts. The gravitational field in the northern part mainly has a northeast striking distribution, the central part has rather cluttered anomaly indications, and the southern part has low gravity and an east-west strike. 3) They have obvious translation properties which caused the northeast striking fractures to extend for more than 10 km. 4) After computer processing and analysis, they still appear clearly in the magnetic field extending upward 30 and 40 km as a linear gradient belt with an east-west strike. This characteristic indicates that the zone appears on the plane as well as that it extends downward to great depths and has at least penetrated the basement. Thus, it is a very important basement fracture.

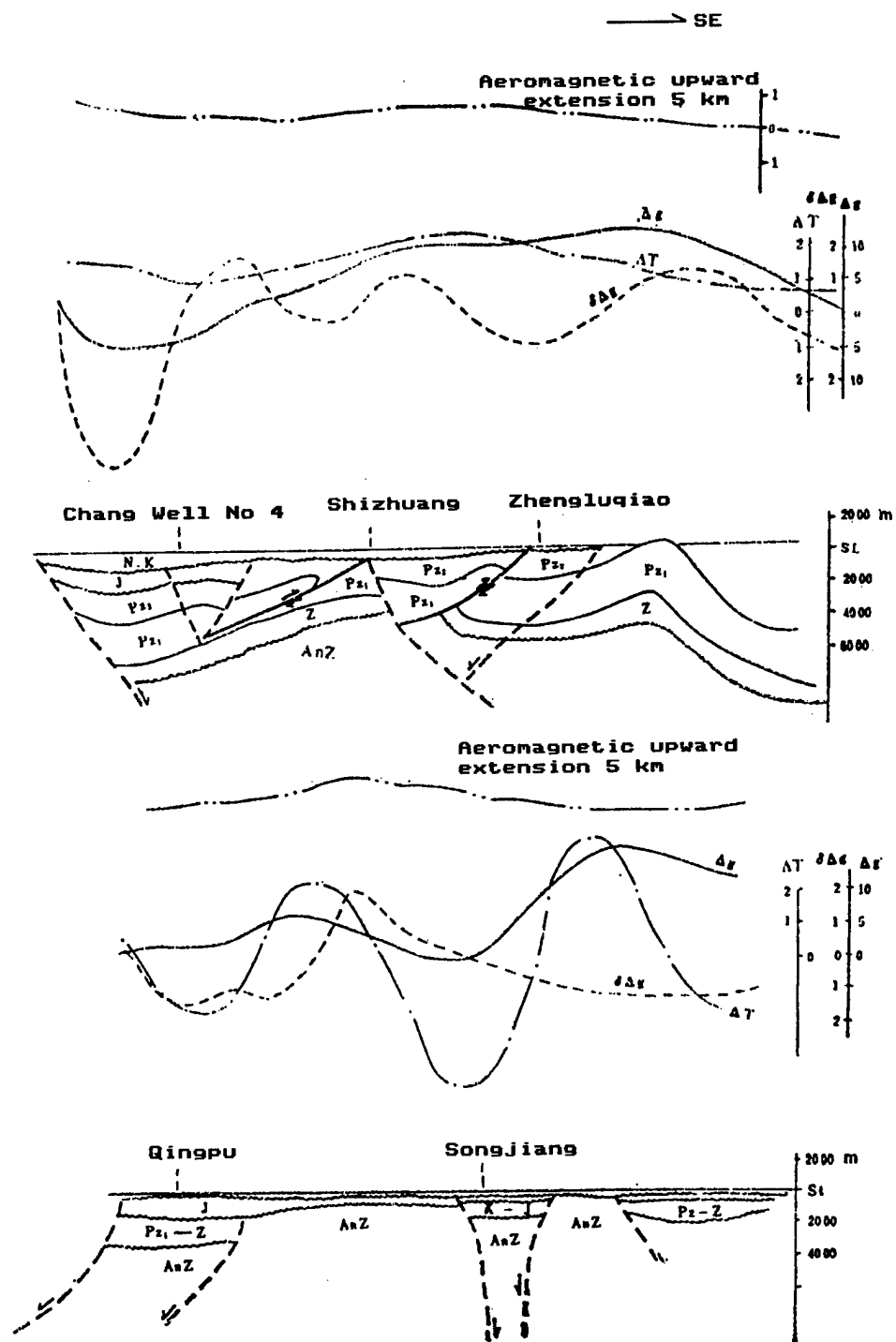

Figure 2. Chart of Basement Uplifts and Corresponding Gravitational and Magnetic Fields (HQ-13 Line)

(6) In the central zone, an enormous positive-negative anomaly belt with an almost east-west strike developed along the Chang Jiang River Basin. It is mainly negative and has values as high as -100 to -300 nT. The magnetic field on the southern part has a rather large gradient with a maximum intensity of several 100 nT. It was discovered during comparison of geological maps that it is an indication of magmatic rock distributed along the fracture which corresponds very well to Ningzheng Ridge.

How was this enormous anomaly belt formed? We know that the Chang Jiang Deep Fracture is located here. If one side of the fracture is treated as a slab-shaped body, the positive and negative values of its magnetic field can be derived using the characteristic angle ϵ ($\epsilon = 90^\circ + \alpha - 2i$, in which α is the dip angle of the slab-shaped body and i is the dip angle of effective magnetization). When $90^\circ < \epsilon < 270^\circ$, the negative value of a magnetic field exceeds the positive value. On this basis, using a slab-shaped body of infinite depth as a model for direct fit (Figure 3), the resulting theoretical curve would be basically identical to the measured curve. For this reason, it is felt that this enormous positive-negative anomaly zone is an indication of a southward-dipping deep fracture (the dip angle is 55°). It remains quite clear when the magnetic field is extended upward 40 km, which indicates that it reaches to a considerable depth.

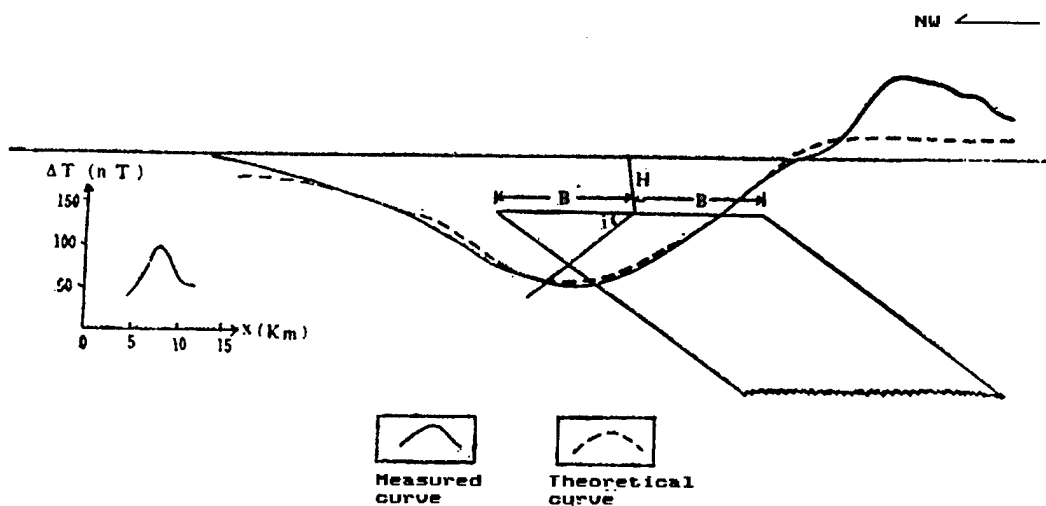

Figure 3. Diagram Comparing Measured Curves of the 6331 Line Chang Jiang Fracture and Direct Fit Results
 $(K = 1,300 \times 4 \pi \times 10^{-6} \text{ SI}, i = 49^\circ, \alpha = 145^\circ, H = 6 \text{ km}, 2B = 30 \text{ km})$

It was discovered for an aeromagnetic map of China that this zone extends westward beyond the Tanlu Fracture through Huo Shan and Que Shan to Baoji and up to the fracture zone at the northern margin of the Qaidam Basin (this zone also shows up as a positive-negative anomaly zone), cutting

across central China. It is of extremely great geological significance and should receive a high degree of attention in the future.

II. Depth of Burial of the Crystallized Basement and Development of Capping Strata

To clarify basement undulations in the Lower Yangzi region, the authors combined aeromagnetic and seismic data to compile a map of the crystallized basement in the Lower Yangzi region (Figure 4).

The first problem in compiling this map was to analyze the distribution of vertical magnetic boundaries and determine the depth of the top of the crystallized basement. The main magnetic boundaries in the Lower Yangzi region are: 1) The top of the Proterozoic metamorphic rock system. This rock system forms the weakly magnetic basement of the Lower Yangzi Paraplatform. The magnetic field displays low, gentle, low frequency regional features. 2) Various types of intrusive and volcanic rock were indicated as a high frequency, cluttered magnetic field which became an interfering factor while studying the shape of the basement. As a result, every effort was made to analyze the shape of anomalies during the mapping process and make upward extensions (5 to 20 km) to filter out interfering bodies in shallow strata while retaining the regional magnetic field. Large section equi-spaced geophysical prospecting surveys have been made of the Lower Yangzi region, and they provided an adequate foundation for compilation of this map. Thus, aeromagnetic and seismic data were combined during the mapping process to determine depths. It was discovered through comparison that the basement depth indicated by aeromagnetic data was basically the same as the depth determined seismically, and the fit was very good in some regions. During the mapping process, we also referred to the Map of Upward Extensions of the Depth of Dual-Layer Bedrock in the Subei [Northern Jiangsu] Region² and the Map of Depth of Metamorphic Bedrock Burial in Jiangsu and Neighboring Regions.³ In brief, these maps provided objective indications of basement undulations in the Lower Yangzi Paraplatform.

Macroanalysis of the map of the depth of crystallized bedrock indicates that the basement of the Lower Yangzi Paraplatform has an extremely complex shape. There are lithologic differences, differences in shape, and differences in the distribution and strike of uplifts and depressions. These point to differences in basement formation and evolution, the effects of structural activity during later periods, and other aspects.

Based on aeromagnetic features and seismic indications of capping strata development conditions, the basement generally subsides in a terraced fashion from southeast to northwest. Fractures with east-west and northeast strikes often are zones of abrupt changes in basement undulations. The basement is buried at considerable depths throughout the region. With the exception of the Jiangnan Old Land, it received very thick Paleozoic sediments. By the Mesozoic, however, there was intense

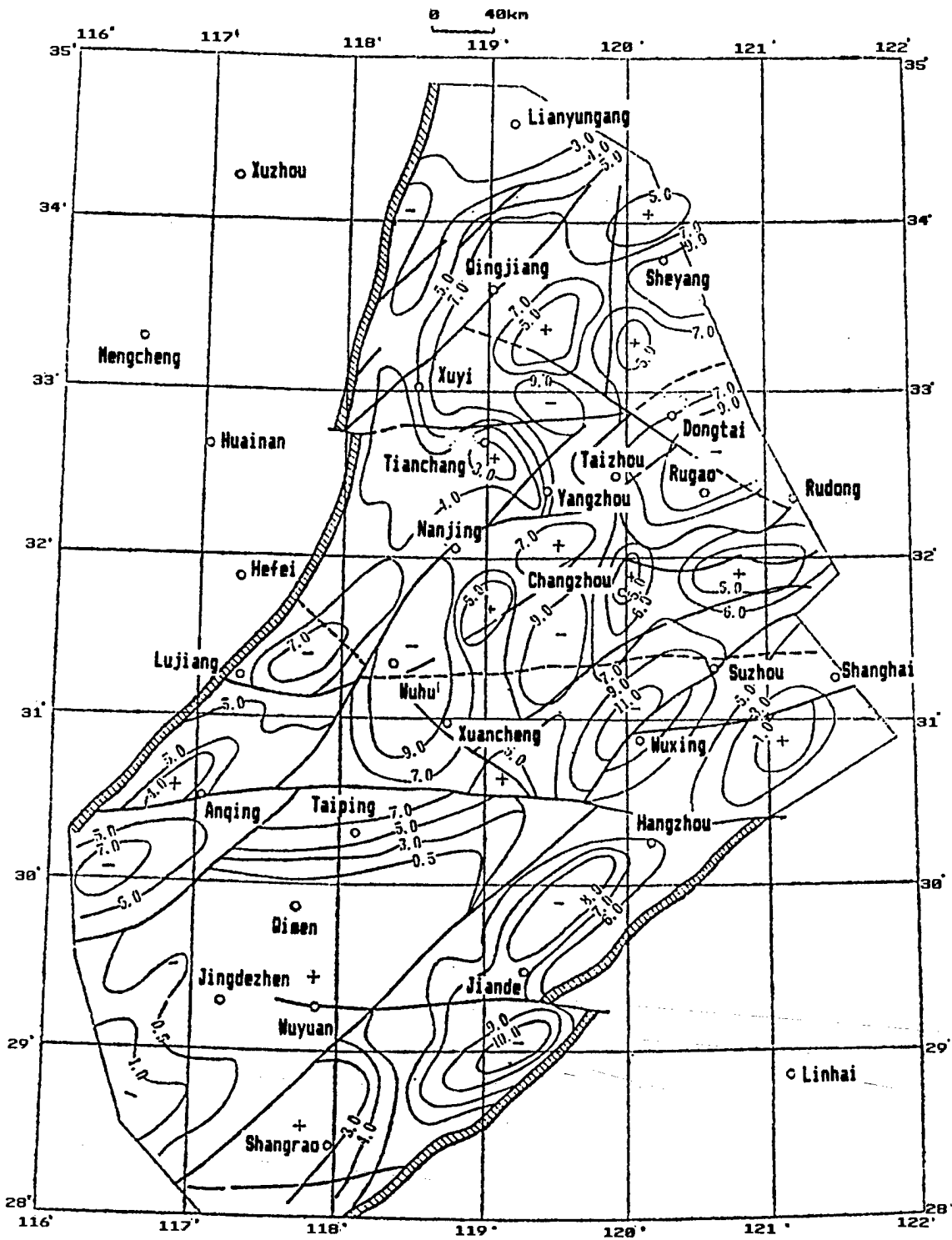

Figure 4. Depth of Crystallized Basement in Lower Yangtze Region (in km)

differential uplifting of the crust, so the distribution and thickness of the Mesozoic vary.

North of the east-west striking Tianchang-Dongtai Fracture, the magnetic field has low and gentle features. The basement is mainly a depression. With the exception of local uplifts at Baoying, Yancheng, and Binhai, the depth of burial is about 7 km. North of the Qingjiang-Xiangshui Fracture, the basement rises and tilts gradually. It eventually crops out over a large area north of Lianyungang. Capping strata sediments developed in this region. According to seismic (HQ-13 and 15 lines) and logging confirmations, the Paleozoic is about 2,000 to 4,000 m thick and the Mesozoic is about 1,000 to 4,000 m thick. This shows that the region's basement underwent continued subsidence after its formation and received very thick capping strata sediments.

The basement is buried at very shallow depths in the region south of the Tianchang-Dongtai Fracture and north of the Anqing-North Hangzhou Fracture, generally at 7 to 9 km. The large fractures which developed in this region increased the complexity of basement shape. In a long and narrow band from Jiujiang to Tianchang, the basement was affected by the Tanlu Fracture and was obviously uplifted. The surface is uneven, with uplifts and depressions. It is buried at 3 to 7 km. In the eastern region, the basement also has an uplifted and subsided shape, but depressions dominate. It is buried at 7 to 9 km. The area to the east of Suzhou and Wuxing was affected by the Zhe-Wan-Gan [Zhejiang-Anhui-Jiangxi] Fracture and the basement has been uplifted to 3 to 5 km. According to seismic (HQ-11 and 13 lines) confirmations, capping strata in this region are primarily Paleozoic and about 5,000 to 7,000 m thick. Their maximum thickness is 9,000 m. The Mesozoic and Cenozoic are underdeveloped and only a few hundred meters to 1,000-plus m thick. This shows that after the Paleozoic, the region subsided gradually and only received sediments in local areas.

The basement crops out over a large area in the Jiangnan Old Land region on the southern side. Capping strata sediments are most developed around Taiping at the northern margin of the Jiangnan Old Land and are mainly Lower Paleozoic. They are 3,000 to 7,000 m thick. It deserves mentioning that this region was affected by the Zhe-Wan-Gan Fracture. Aeromagnetically, the Hangzhou and Jiande regions show up as an enormous band of basement depressions with capping strata sediments about 6,000 to 8,000 m thick. Their maximum thickness is 10,000 m (HQ-5 line).

Aeromagnetic anomaly features in conjunction with comprehensive large-section geophysical prospecting data indicate that during its later evolution the Lower Yangzi Paraplatform was affected by the two east-west striking Tianchang-Dongtai and Anqing-North Hangzhou Fractures, which caused obvious variations in the basement and capping strata. It is possible that the Paleozoic may have developed completely and is most completely preserved in the northern part. It crops out locally in the central part and was eroded. Because it crops out over a large area in the southern part, it has been partially destroyed by erosion and the Upper

Paleozoic is nearly absent. Moreover, the Mesozoic and Cenozoic are most developed in the northern part, and the sediments are thickest there (generally 1,000 to 4,000 m, and as thick as 6,000 m). They are only a few hundred or 1,000-plus meters thick in the central part, and are completely absent in the southern part. This shows that capping strata sediments in the Lower Yangzi region were controlled structurally by the two east-west striking fractures. They assumed a terraced distribution similar to the features shown in the regional magnetic field.

To determine the thickness of Paleozoic carbonate rock accumulations and facilitate early breakthroughs in prospecting for Paleozoic oil and gas in the Lower Yangzi region, the authors used aeromagnetic, seismic, gravitational, and logging data for comprehensive analysis to compile an isopach map for Paleozoic and Triassic strata in the region (Figure 5).

III. Paleozoic Oil and Gas Prospects

The Lower Yangzi region has very good oil and gas prospects. With the exception of the Cenozoic, the Paleozoic carbonate rock has very good oil reservoiring properties. It is an important target for future oil and gas prospecting. Below, we will further analyze Paleozoic oil and gas prospects.

1. A favorable region: the Nanjing-Nantong region

This is known as the "Nan-Nan" region. It is bordered on the north by the Tianchang-Dongtai Fracture, on the south by the Anqing-North Hangzhou Fracture, on the west by the Tanlu fracture and on the East by the Zhe-Wan-Gan Fracture. Horizontally, it has a terraced shape and covers an area of about 80,000 km².

Structurally, this region is rather stable. Although fractures have developed and may have damaged oil and gas and pools, it also is possible that they may have played a constructive role. The carbonate rock sediments may be as much as 5,000 to 7,000 m thick and the maximum thickness may be 11,000 m (Figure 5). This suite of strata is distributed over a wide area and the preservation conditions are good. The Upper and Lower Paleozoic are very developed and there also are specific generation, reservoiring and capping conditions.

Basement uplifts are very developed in this region. There are conventional bedrock uplifts as well as uplifts caused by intrusive rock (penetrating structures). According to high-accuracy aeromagnetic surveys and other geophysical data, this region contains a total of 28 Paleozoic uplifts. This was especially conducive to early migration and accumulation. Moreover, there are extremely active indications of oil and gas. The degree of heat metamorphism and the temperature gradient both are rather low (according to Wang Jun [3769 6874], 1985). Regional capping strata (Mesozoic and Cenozoic) also are developed and are distributed over a wide area. They are not very thick (generally less than 2,000 m), however, so

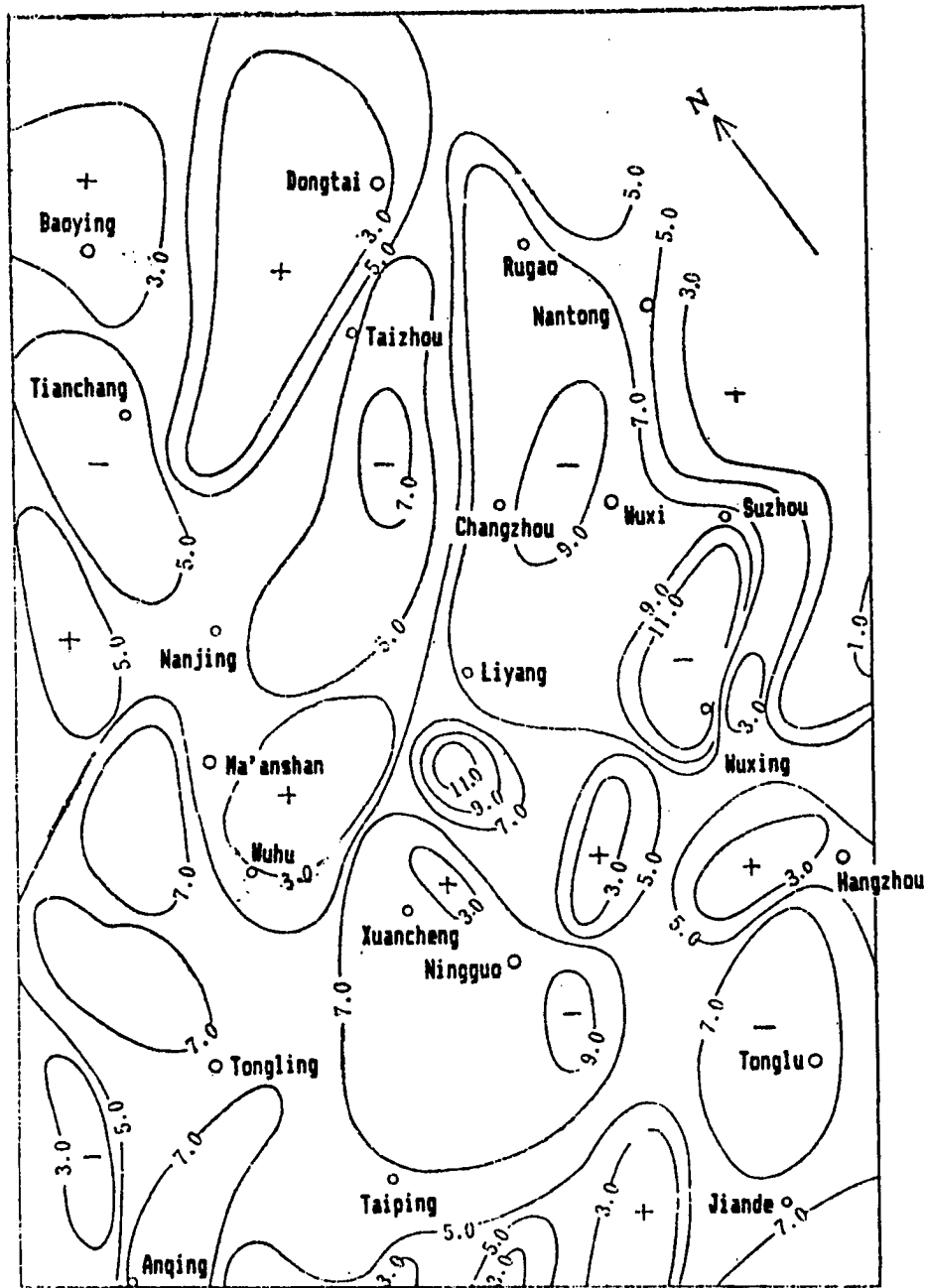

Figure 5. Sinian-Triassic System Isopach Map of Lower Yangzi Region (km)

exploratory drilling is easy. In addition, a considerable amount of work has been done here, and communications, economic, geographical, and technical conditions also are good.

2. A relatively favorable region: the Subei region

This area is located south of the Xiangshui-Qingjiang Fracture and north of the Tianchang-Dongtai Fracture. Horizontally, it has a deltaic shape and covers an area of about 18,000 km².

Structurally, this is the most stable region. Paleozoic carbonate rock developed and is 3,000 to 5,000 m thick. Magmatic rock is not developed, and indications of oil and gas to varying degrees have been seen. The Mesozoic and Cenozoic capping systems are extremely developed, however, being 1,000 to 4,000 m thick and as much as 6,000 m thick. This would make prospecting very difficult given existing technical conditions, so for the time being it should be treated as a rather favorable region.

3. A rather poor region: the northern margin of the Jiangnan Old Land

Located south of the Anqing-North Hangzhou Fracture, this is the Taiping region. It was discovered through aeromagnetic surveys and geological observations that magmatic rock has developed and that the entire Paleozoic outcrops at the surface and has been severely eroded. The Upper Paleozoic basically is absent and the Lower Paleozoic is incompletely preserved. Some areas also have Sinian and Cambrian system outcrops, which is extremely unfavorable for oil and gas preservation. Although the bituminous coal proves that oil and gas were produced and accumulated there, the intense magmatic activity and the high degree of thermal evolution mean that oil and gas prospects are not very good. Of course, it still is possible that some local areas may have condensate and natural gas pools.

Footnotes

1. Ren Jishun [0117 4764 5293], et al., ZHONGGUO DADI GOUZAO JI QI YANHUA [CHINESE TECTONICS AND THEIR EVOLUTION], Dizhi Chubanshe, 1983.
2. Map compiled by the Petroleum Group in the Central Office of the Aerogeophysical Prospecting Brigade, State Geology Bureau, 1977.
3. Map compiled by the Petroleum Geophysical Prospecting Research Brigade, Ministry of Geology and Mineral Resources, 1982.

12539/9365

Water Injection at Daqing Proves Costly

40100014 Beijing XINHUA in English 1151 GMT 21 Feb 88

[Text] Harbin, 21 Feb (XINHUA)--Application of modern technology will make Daqing, the largest oil producer in China, keep its present annual output of 350 million bbl for another 8 years, according to an official from the Heilongjiang Province oil field.

More than 20 institutes are engaging in research on exploration of new oil reserves and oil well drilling.

After 27 years of exploitation, most of the easily accessible oil at Daqing now contains water which was injected into the ground during the early stages of the oil field's development in order to maintain pressure.

Now, each barrel of oil pumped out from the thick strata contains more than 70 percent water. This has led to an output reduction at an annual rate of 28 million bbl of oil. Dehydrating the oil and treating the waste water consumes a lot of energy and funds.

To tackle this problem, local scientists turned their attention to thin oil seams. They developed new prospecting devices which can monitor oil-bearing strata that are just 0.2 meters thick.

The oil field has invested 100 million yuan annually to put these research results into production and imported some advanced equipment.

It has also sent over 1,000 oil technicians to study up-to-date oil technology in other countries.

/9365

Design of Nuclear Heat, Power Co-Generation Plant Detailed

40080042a Chengdu HE DONGLI GONGCHENG [NUCLEAR POWER ENGINEERING] in Chinese Vol 8 No 6, Dec 87 pp 1-13

[Article by Liu Jukui [0491 5112 1145], manuscript received 10 November 1986: "Selection of Reactor for Small Nuclear Power and Heat Co-Generation Plant and Its Design Characteristics"]

[Text] I. Introduction

As society grows, the demand for heat also increases. More than 70 percent of primary energy resources is consumed to generate heat. Power generation, however, only consumes approximately 20 percent. Over 400 billion tons of coal are used for heating each year. In addition, a great deal of oil is also consumed. This stresses the transportation system, pollutes the environment, and wastes resources. In the future, a nuclear power and heat co-generation plant will be built near a town or city where the demand for steam and heat is centralized. This is a novel way to conserve energy, relieve transportation load, and reduce environmental pollution.

Although constructing a nuclear power and heat co-generation plant is a promising way to conserve energy, designers must first consider factors which make such a plant truly clean, safe, and cost effective. A summary of past experience tells us that the design objectives of a small nuclear power and heat co-generation plant are as follows:

- (1) low capital requirement, in the range of 2,500-2,800 yuan/kW;
- (2) construction time--4 years with one reactor and 5 years with two reactors;
- (3) reliability--usable rate 85-90 percent, load factor over 80 percent;
- (4) no major incident involving the fracture of a large-diameter pipe (more than 100) and loss of water. Core meltdown probability is less than 10^{-6} reactor/yr. In the absence of normal internal and external power, the

device itself and battery power can cool the reactor. Due to its high safety and reliability, it may be used in populated areas;

(5) simplicity, compactness, and small scale construction;

(6) eliminating the need for a huge reactor building to reduce the load on the foundation. Hence, the nuclear power and heat co-generation plant may be built on a beach, on soft soil, and in earthquake areas. The degree of freedom in site selection is similar to that for a train station;

(7) no radioactivity in heat and hot water supplied, based on natural background level;

(8) double layer structured reactor building that can withstand pressure and can be sealed. In the event of leakage, the surrounding environment will not be contaminated by radiation.

II. Selection of Reactor Type

The bases for the selection of the reactor are that the eight designed objectives discussed above are met, it is technically feasible and it satisfies the demand for steam.

A pressurized-water reactor, boiling water reactor, or high-temperature gas-cooled reactor may be chosen for the small nuclear power and heat co-generation plant. We are more experienced in the experimental research, design, manufacture, installation, and operation of pressurized-water reactors. Based on practicality, we should choose a pressurized-water reactor.

The demand for steam is the basis for the selection of the type of reactor to use. Table 1 shows the demand parameters of several major steam users.

Based on the steam consumption parameters shown in Table 1, the majority is low and medium pressure steam. Therefore, either a pressurized-water reactor or a boiling water reactor can meet the steam requirements. However, the pressure of a boiling water reactor is generally 6.86 MPa and the core outlet temperature is 285°C. Hence, the steam temperature in the tertiary loop is less than 225°C. The core outlet temperature of a pressurized-water reactor is 310-325°C. As it is capable of generating medium pressure steam in the tertiary loop, it has a wider range of applications.

In summary, our first choice should be to use pressurized-water reactors for the heat and power co-generation nuclear plants. In addition, because the steam requirement is usually less than 100 t/h, reactor power should be under 600 MW. It is more appropriate to build two reactors in the same plant to supply both heat and power.

Table 1. Steam Consumption by Chemical Plants

Plant	Pressure 10 ⁵ Pa	Temperature °C	Amount t/h	Percentage
Shanghai Jinshan Petrochemical Plant	10-16 35-40	270-285 320	700-1,000 285	77.8 22.2
Liaoyang Chemical Fiber Company	8-13 39 100	260 450 540	665-865 417 5	67.2 31.6 0.40
Jilin Chemical Company	8-13 20 30 70	280 320 260 360	1,121 61 104 16	86.1 4.7 8.0 1.23
Dalian Ganjingzi Area	1.2-1.5 8-13 16 32		65 839.7 12 86	6.50 84 1.20 8.60

The following discussion is based on a 450 MW reactor.

There are many types of pressurized-water reactors, including the classical circulation design, compact design (NP-300, CAS-3G), integrated layout, and pool layout (PIUS, ISER). The circulation design is a large, complicated system which takes a long time to build and costs more. It is not suited for a small plant.

III. Design of Small Nuclear Plant for Heat and Power

1. Principal Parameters and Primary Process Flowchart

The key issue in the design of a heat and power co-generation nuclear plant is the selection of the principal parameters and primary process flow. Based on the classical way of thinking, a water-steam-steam process is chosen for the plant to be constructed at Shanghai Jinshan Chemical Plant (Figure 2). The operating pressure of the reactor and the primary loop is 15 MPa. The steam pressure in the secondary loop is 5 MPa. The tertiary loop generates 75 t/h of saturated steam at 4 MPa, 320 t/h of saturated steam at 1.6 MPa and 52,000 kW of electricity (per reactor). The disadvantages of this flow process are: 1) leakage of the heat exchanger may bring radioactivity into the steam in the tertiary loop. Therefore, it is necessary to install detectors and the associated emergency equipment. 2) The thermal efficiency of the steam-steam heat exchanger is poor. It requires several heat exchangers (nine units per reactor) and takes a lot of space. 3) It requires too many water pre-heaters in the tertiary loop. The system is complex and the construction cost is high.

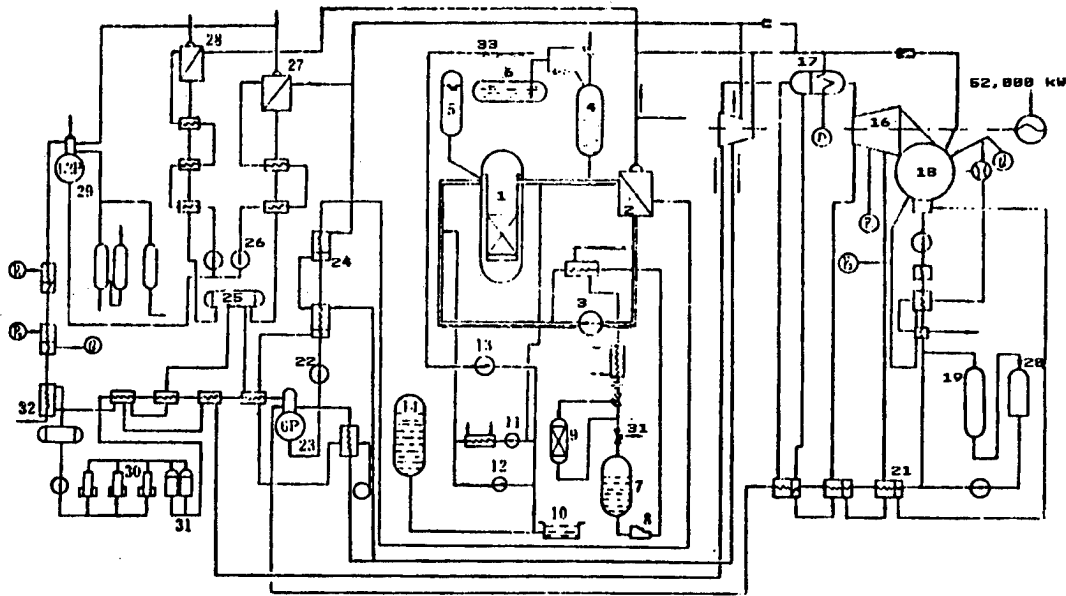

Figure 2. Flowchart of Nuclear Power Plant for Heat and Power*
 * P = 98066.5 Pa

Key:

- | | |
|--------------------------------------|-------------------------------------|
| 1. Reactor | 18. Condenser |
| 2. Steam generator | 19. Hydrogen ion exchanger |
| 3. Main Pump | 20. Mixer |
| 4. Pressure stabilizer | 21. Low pressure heater |
| 5. Safety tank | 22. Main water pump |
| 6. Pressure release box | 23. High-pressure gas removing pump |
| 7. Volume control box | 24. High-pressure heater |
| 8. Filling pump | 25. Water tank |
| 9. Resin bed | 26. Relay pump |
| 10. Safety shield pit | 27. Low-pressure evaporator |
| 11. Reactor shutdown cooling pump | 28. Medium-pressure evaporator |
| 12. Safety pump | 29. Low-pressure de-oxygenator |
| 13. Sprinkle pump | 30. Electromagnetic filter |
| 14. Water exchange tank | 31. Mixer |
| 15. High pressure turbine | 32. Tertiary loop water supply |
| 16. Low pressure turbine | 33. Safety shield sprinkle |
| 17. Steam-water separation re-heater | 34. To boron recovery system |

Based on the experience in the water-steam-steam process, in order to ensure that there is no radiation in the steam, the plant still uses three loops. To simplify the system, downsize the equipment, and improve reliability and safety, we choose to use the water-water-steam process. Figure 3 shows the major parameters and the flowchart.

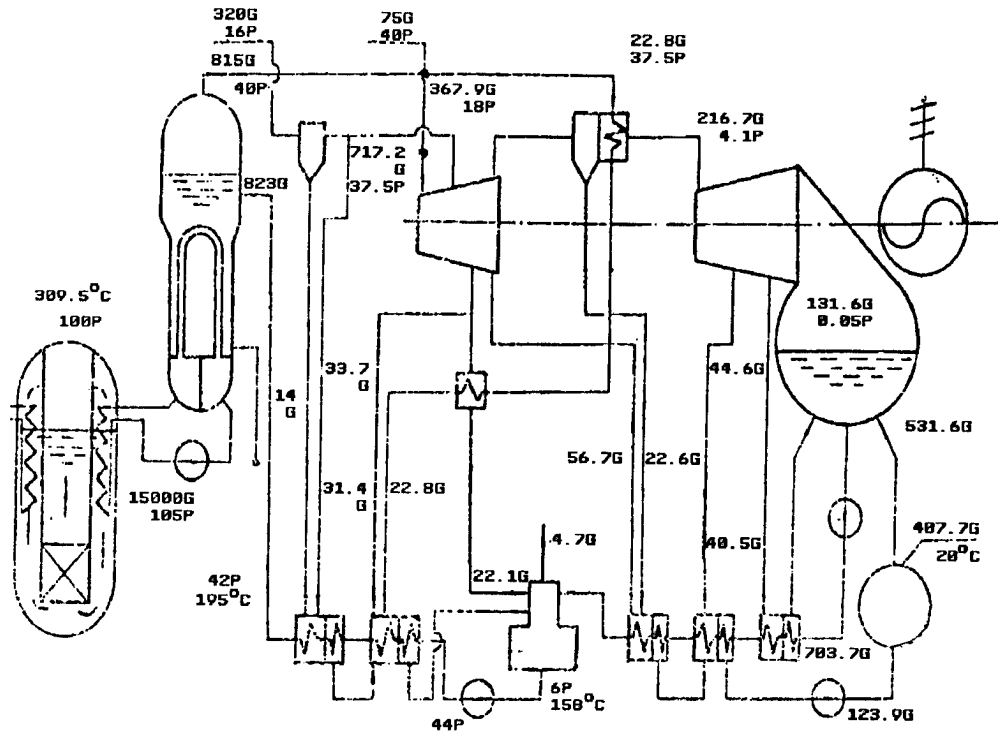

Figure 3. Flowchart for Thermal System of a Small Nuclear Power and Heat Co-Generation Plant*
 * G = 1 t/h

The operating pressure and temperature in loops 1, 2, and 3 are selected based on the premise that the tertiary loop must supply saturated steam at 3.92 MPa and by judging the relative size of the heat exchangers in loops 1 and 2 to ascertain that the pressure in loop 1 is 10 MPa. Because the reactor operates at a stable pressure, the average core outlet pressure is 309.5°C, the coolant flow rate is 14,000 t/h, and the core inlet temperature is 289.5°C.

The intermediate loop is a high pressure water loop which operates at 10.5 MPa. This makes it difficult for radiation to leak into the tertiary loop. The intermediate circuit may be a two, three, or four turn loop. In this case, it is temporarily designed as a two turn loop.

The flow is 15,000 t/h. The main pump is a wet spindle pump. The hot end temperature is 280°C and the cold end 258.5°C.

The tertiary loop steam pressure is 4 MPa. There are two U-shaped steam generators. The heat exchange area is 2,666.5 m² per unit. The design area is 3,066.5 m² with 15 percent excess.

The pipes, valves, and equipment in loops 2 and 3 are made of low alloy steel or carbon steel.

Table 2 shows the effect of the water-water-steam process and the water-steam-steam process on heat exchange. It is not difficult to see that the advantage of the design is that the pressure in the primary loop is significantly reduced while the steam temperature in the tertiary loop remains the same. Furthermore, the temperature difference between loops 2 and 3 is larger, which reduces the size and volume of the major equipment. Consequently, the scale of the plant can be reduced and the construction cost can be lowered.

Table 2. Comparison of the Two Processes

Item		Water-water- steam process	Water-steam- steam process
Reactor power	MW	450	450
Primary loop pressure	MPa	10	15
Primary loop flow	t/h	14,000	12,000
Core outlet temperature	°C	309.5	307.5
Core inlet temperature	°C	289.5	282.5
Loop 3 steam pressure	MPa	4	4
Loop 3 steam temperature	°C	250	250
Temperature difference between loops 1 and 2	°C	30.3	30.6
Temperature difference between loops 2 and 3	°C	22.4	16.2 (Low pressure evaporator) 17.5 (Medium pressure evaporator)
Heat exchanger area in loops 1 and 2	m ²	2,832	3,000
Heat exchanger area in loops 2 and 3	m ²	6,133	12,674

Under the same demand for steam, the water-water-steam process can generate 5,000 kW of power per reactor.

In summary, the water-water-steam process can better insure that the steam in the tertiary loop is radiation free. The heat exchanger is smaller and it operates reliably. The construction cost is low and the thermal

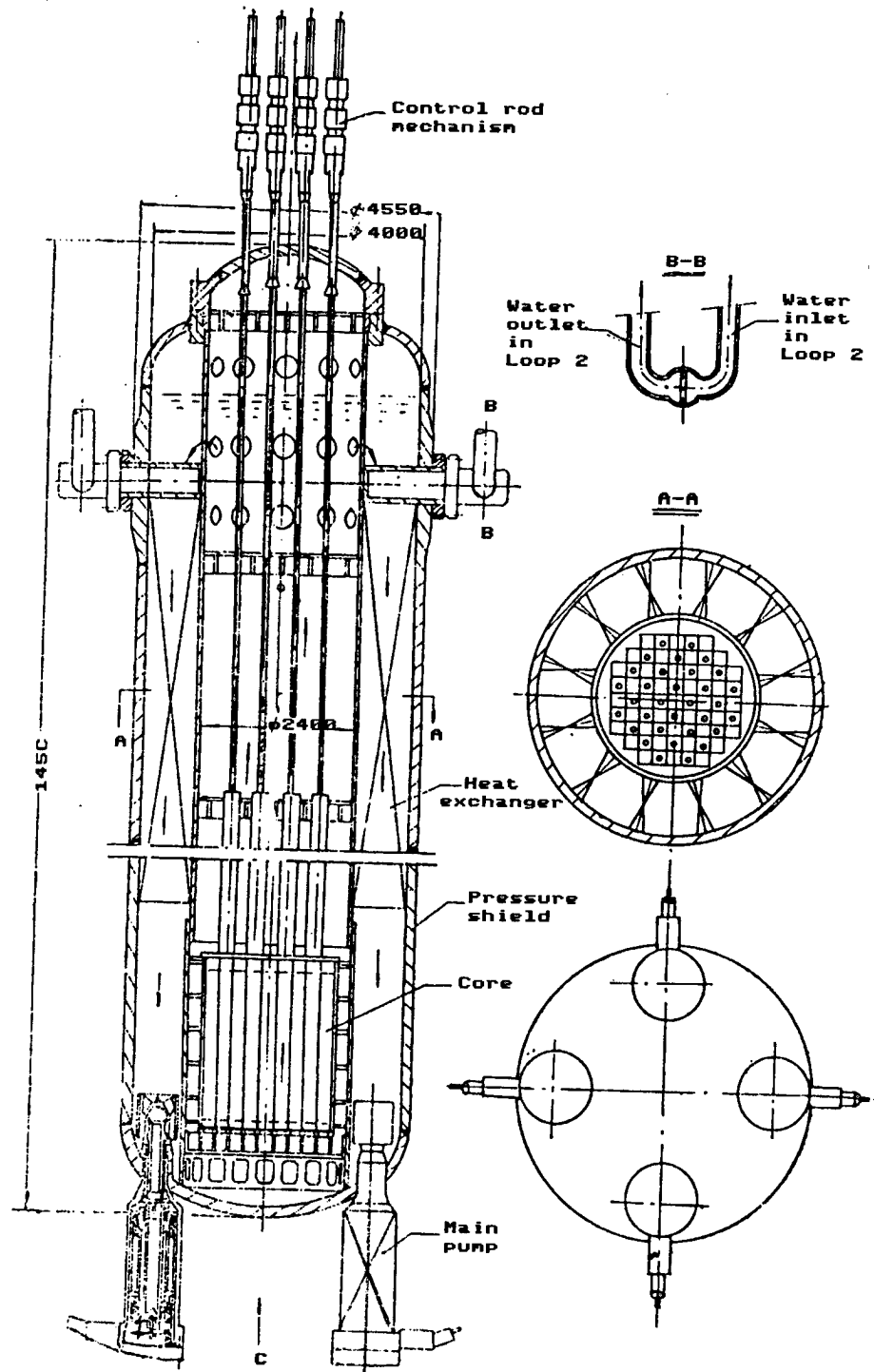

Figure 4. Integrated Pressurized-Water Reactor

efficiency is improved. Therefore, it is appropriate to choose the water-water-steam process for a small heat and power co-generation nuclear plant.

2. Reactor Design

Figure 4 shows an integrated reactor. It consists of a core, 12 U-shaped heat exchanger tubes, 4 main pumps, 32 sets of control rod driving mechanisms, a pressure shield, and other reactor components. The reactor pressure is self-stabilizing. On the average, the core contains 0.1 percent of steam. The steam space at the top of the pressure shield is 12.5 m^3 , which is 60 percent larger than that in the pressure stabilizer of an ordinary reactor (of the same power) with a scattered layout.

Figure 5 shows the core layout and the fuel component cross-section. The core consists of 69 fuel components. The diameter of the fuel rod is 8 mm. The average heat flux is $0.27 \times 10^6 \text{ kcal/m}^2 \text{ h}$ and the mean thermal output is 7.9 kW/m . The volumetric power density is 64 kW/l and the mean coolant flow rate is 3.53 m/s . The temperature at the center of UO_2 is 485°C and the maximum temperature is $1,500^\circ\text{C}$. UO_2 is doped with Gd_2O_3 which is toxic and combustible. Boric acid is not used to control reactivity.

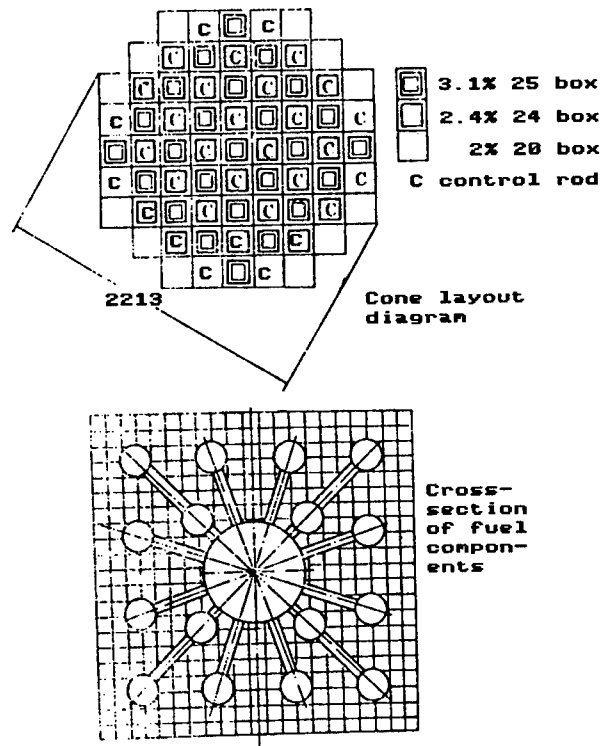

Figure 5. Reactor Core Layout and Fuel Component Cross-Section

Figure 6 shows the structure of the heat exchanger inside the core. Twelve water-water heat exchangers are placed at the upper part of the core. The area of each exchanger is 236 m^2 and the tube is made of $0\text{Cr}18\text{Ni}9\text{Ti}$. The U-shaped tube is connected to the tank through an in-welded hole inside.

D-direction view

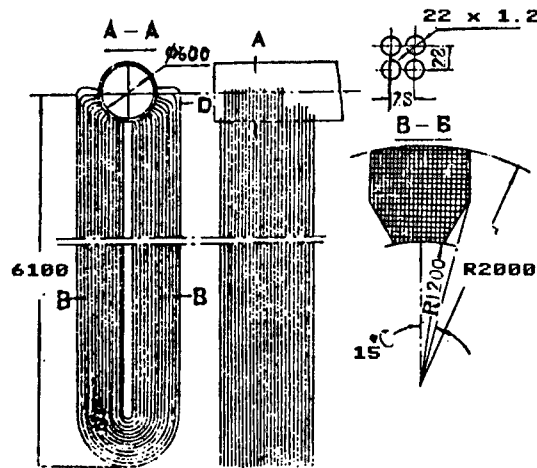

Figure 6. Heat Exchangers Inside Reactor

The vertical distance between the bottom of the heat exchanger tube and the top of the core is 1 m to prevent the secondary loop from becoming seriously radioactive.

The four main pumps are located at the bottom of the pressure shield. It is similar in structure as the main pumps in a boiling water reactor. They are reverse wet spindle pumps. The head pressure of the main pump is 0.13 MPa and the flow rate is 3,500 t/h. The hot pump power is 210 kW. The electrical power for the main pump is rated at 300 kW. Since natural circulation of the coolant in the primary loop is good, the main pump will not be equipped with an idle flywheel.

The largest pipe connecting the reactor to the outside is the drain pipe of the purifying system with an inner diameter of 50 mm. Thus, only small water leak incidents must be considered. The outgoing pipe of the purifying system extends from the upper part of the pressure shield through the heat exchangers in the reactor to the lower part of the shield. Other outlets in the primary loop are higher than the common tank for the heat exchangers. In case there is a small water leak, steam escapes first. In addition, the core is buried under 8 m of water, corresponding to 100 m^3 of water. Therefore, it is highly impossible to expose the core.

3. Primary Loop Auxiliary System

Figure 7 shows the reactor and the primary loop auxiliary system. It mainly consists of a safety injection and sprinkle system, purification system, gas removal system, equipment cooling water system, water and chemical additive makeup system, pressure suppressing system for the

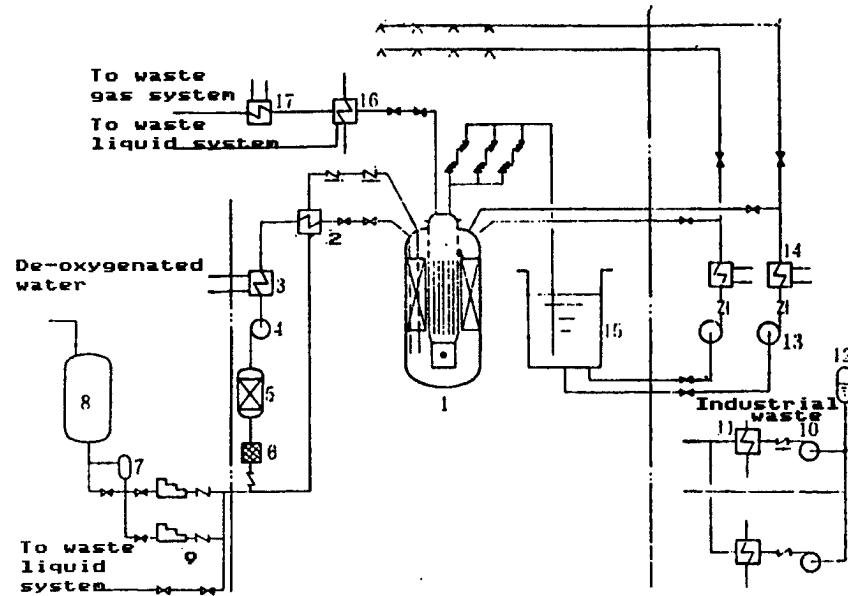

Figure 7. Flowchart of Primary Loop Auxiliary System

Key:

- | | |
|-----------------------------------|--|
| 1. Reactor | 10. Equipment cooling water pump |
| 2. Regenerative heat exchanger | 11. Equipment cooling heat exchanger |
| 3. Nonregenerative heat exchanger | 12. Wave box |
| 4. Purifying pump | 13. Low-pressure injection and sprinkling pump |
| 5. Purification bed | 14. Recirculating condenser |
| 6. Filter | 15. Pressure suppressing pool |
| 7. Chemical container | 16. Condenser |
| 8. Makeup water tank | 17. Gas condenser |
| 9. Makeup water pump | |

reactor, and its pressure shield, pressure safety system, and sampling and decontamination system.

4. Intermediate Loop and Its Auxiliary System

The system in the secondary loop (Figure 8) is as follows:

(1) The Primary System

The operating pressure in the intermediate loop is 10.5 MPa. It consists of two circuits. Each circuit has a main pump and a steam generator. The main pipe is made of No 20 carbon steel. The outer diameter is 600 mm and the wall thickness is 25 mm. The circulation flow rate is 7,500 t/h and the flow speed is 11.20 m/s. The main pump is a wet spindle pump with a lift of 80 m. Its hot power is 2,040 kW and its cold power is 2,800 kW. Each circuit is equipped with a steam generator. Its heat exchange area

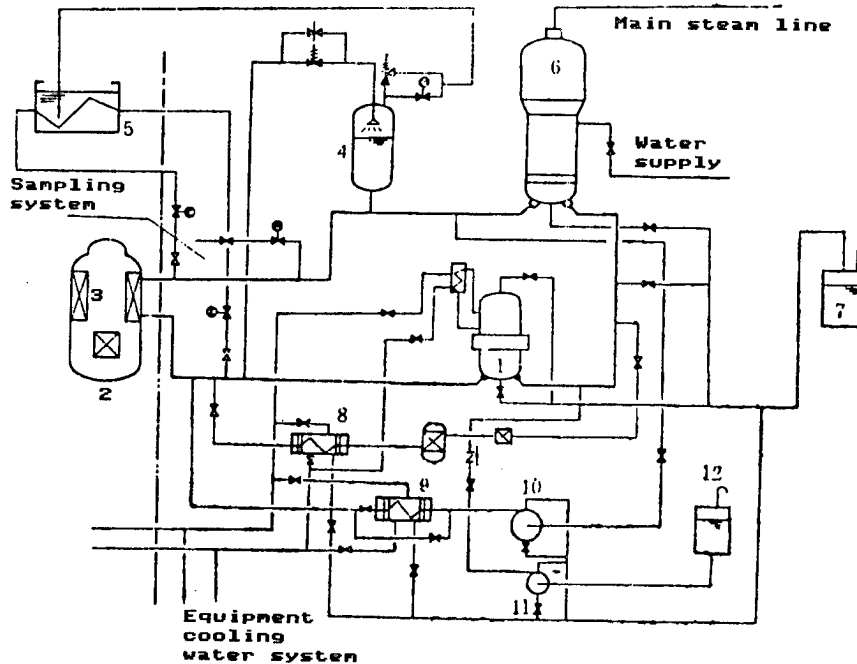

Figure 8. Flowchart of Secondary Loop

Key:

- | | |
|----------------------------|------------------------------|
| 1. Circulating pump | 7. Water tank |
| 2. Reactor | 8. Purifying condenser |
| 3. Main heat exchanger | 9. Shutdown condenser |
| 4. Pressure stabilizer | 10. Shutdown cooling pump |
| 5. Pressure relieving pool | 11. Water makeup pump |
| 6. Steam generator | 12. De-oxygenated water tank |

is 3,066.5 m², maximum outer diameter is 3.8 m, total height is 17 m and total weight is 180 t. The steam generator is made of 16 MnR steel and the pipes are made of No 20 steel. The construction cost is low (approximately 3 million yuan each). Its structure and parameters are shown in Figure 9.

The heat exchanger in the reactor and the intermediate loop are connected by a tank. Each tank is connected to six heat exchangers. Furthermore, an isolating valve is installed to isolate the heat exchanger from the outside environment in the event of a leak to prevent the escape of radiation.

(2) Pressure Safety System

The pressure safety system consists of a pressure stabilizer and its associated valves and pipes. Because the water in the intermediate loop is radiation free, it may be discharged into the pool.

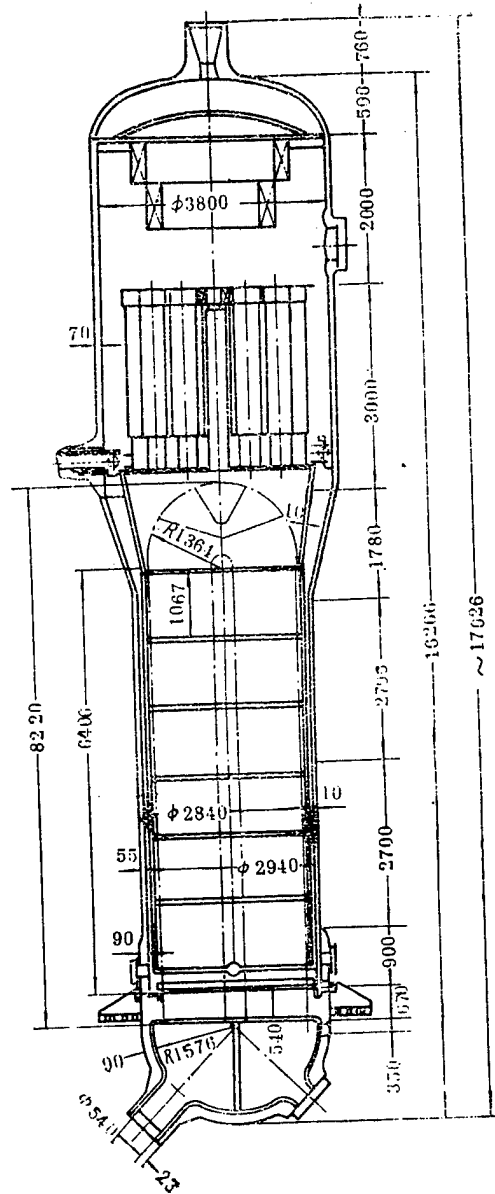

Figure 9. Steam Generator in Loops 2 and 3

(3) Purification System

Each loop is equipped with a purification system. The system is very simple. A continuous flow is established by the head pressure of the pump. The downward flow decreases the temperature, but not the pressure. The flow in the loop is 2-3 percent of the total flow. It is primarily composed of regenerative and nonregenerative heat exchangers, electromagnetic filters, and ion exchangers.

(4) Shutdown Cooling System

Heat is transferred from the primary loop to the water in the heat exchanger in the reactor by natural circulation. The water in the intermediate loop is circulated by the shutdown cooling pump and the heat is transferred through the shutdown condenser.

The equipment cooling water system is shared by the primary loop equipment cooling water system. In addition, it includes a sampling system, a water make-up system, and a drain system.

IV. Reactor Building and Nuclear Annex

Because of the integrated layout of the reactor building, no major pipe fracture incident is possible. Also because the pressure in the primary loop is only 10 MPa, it only requires a pressure suppressing system and a concrete safety shell. The shell is 16 m in inner diameter and 2 m in wall thickness. It is lined with stainless plate. The pressure suppressing pool has 5.2 m of water and each reactor pool has a capacity of 750 m³. The space on top of the fluid surface is approximately 420 m³. In addition, the dry part of the safety shell has approximately 1,750 m³ in volume. Other than tanks and valves connected to the heat exchangers in the reactor, there is major equipment there. The height of the safety shell is approximately 23.2 m. A small room is built at the bottom of the reactor with a passageway to enter the plant for the installation, replacement, and maintenance of the main pump. The passageway has a sealed gate to prevent the escape of radiation. This small room is ventilated.

Both reactors share a piece of fuel replacement equipment. The fuel storage pool and fuel replacement pool are located in between the two safety shells. A 50-ton bridge-type crane is installed at the upper part of the fuel replacement pool to lift up the pressure cap or the core basket.

The reactor building and the fuel plant in combination are 22 m in width and 40 m in length, and they occupy 880 m² in area.

The reactor building is equipped with an entrance to lift equipment in and out of the place.

The nuclear annex is equipped with systems for low pressure injection, sprinkling, equipment cooling, water drainage, purification, water make-up, waste resin processing, decontamination, waste gas processing, sampling, and isolation. It also has a physicochemical laboratory, an electrical shop, a mechanical shop, and a room for personnel on duty. The upper part is the ventilation system which occupies approximately 1,638 m² of space. The nuclear island covers 2,518 m² of area and has 20,000 m² of building space. In summary, the scale of the construction of the plant is approximately 33 percent of that of a scattered layout.

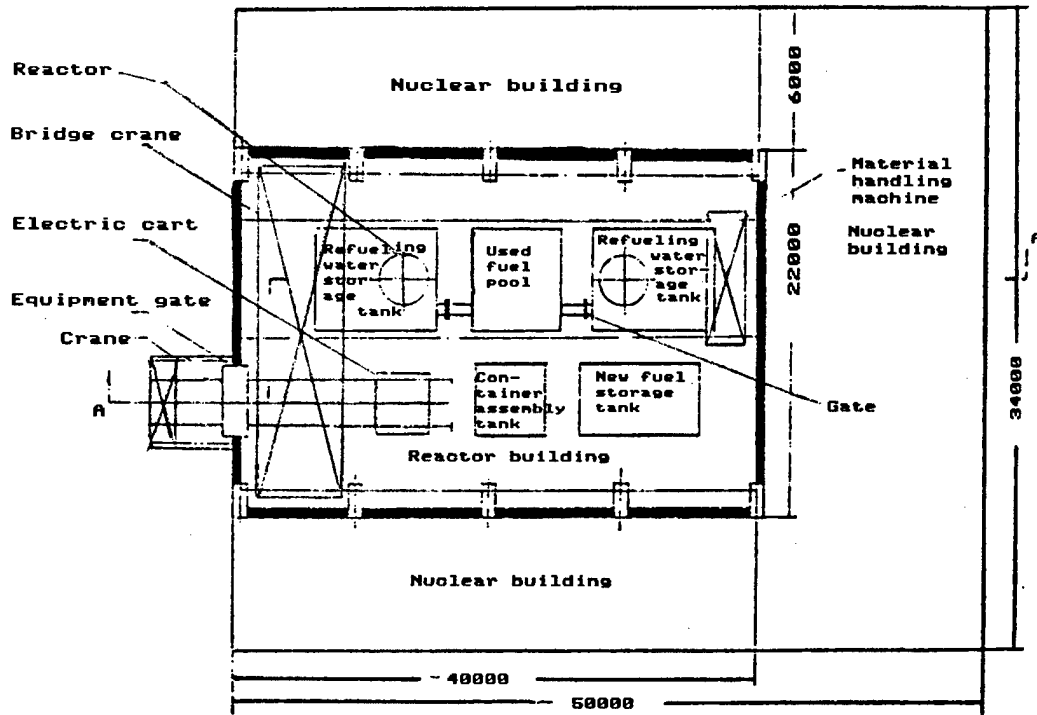

Figure 11. Layout of Nuclear Building

V. Preliminary Analysis of Total Investment, Replacement of Oil Consumption and Economic Benefit

The initial investment is approximately 680 million yuan, 30 percent lower than the original plan. Compared to the original plan, this is a conservative estimate.

The load factor of the heat and power co-generation nuclear plant is estimated to be 80 percent (as compared to 70 percent in the original plan). The major reason is the simplicity of the system. In valves alone we can reduce the number by one-third (nuclear island portion). The pressure in the primary loop is reduced from 15 MPa to 10 MPa. The reliability of the equipment can be significantly improved. Water-water heat exchangers are used between the primary and secondary loops which are far more reliable than water-steam heat exchange type of steam generators. Thus, the calculation of replacement of oil consumption is made based on 7,008 hours of continuous operation per year.

The water pumps in the primary loop consume relatively little power. In hot working conditions, the eight pumps for both reactors use 1,600 kW of electricity. The power consumed by the water pumps in the tertiary loop can be saved by 20 percent. However, the main pumps in the secondary loop consume more power. They more or less cancel each other. Nevertheless,

some power can be saved in the pressure stabilizer, waste treatment and boron recovery systems, as well as by the high-pressure safety injection pump. Therefore, the power requirement for a two-reactor plant is estimated to be 16.5 MW. Other factors to be taken into account are based on the parameters in the feasibility study report on the heat and power co-generation nuclear plant at Shanghai Petrochemical General Plant (September 1985). The calculation is as follows:

The amount of oil replaced by the power generated is Q_1 .

$$Q_1 = (E_1 - E_2) T_e \times q_1 = 1.45 \times 10^5 \text{ t/a}$$

The amount of oil replaced by the low-pressure steam generated is Q_2 .

$$Q_2 = [(W_1 \times T_e) - W_3] \times (1,000\Delta h_1/1000000) \times q_2 = 2.99 \times 10^5 \text{ t/a}$$

The amount of oil saved by the medium-pressure steam generated is Q_3 .

$$Q_3 = W_2 T_2 (\Delta h_2/1000) q_2 = 7.10 \times 10^4 \text{ t/a}$$

The total amount of oil replaced per year is $Q = Q_1 + Q_2 + Q_3 = 5.15 \times 10^5$ t/a. E_1 is the power generating capacity of the nuclear plant in kW. E_2 is the power consumed by the plant in kW. $W_1 = 640$ t/h is the amount of low-pressure steam supplied to the outside. $W_2 = 150$ t/h is the amount of medium-pressure steam supplied externally. $W_3 = 44,000$ t/a is the amount of steam used by the plant itself. $q_1 = 0.212$ kg/kW·h is the oil consumed to generate power. $q_2 = 104.8$ kg/Mcal is the oil consumed for heating. $\Delta h_1 = 642.1$ kcal/kg is the enthalpy rise in the low-pressure steam and $\Delta h_2 = 645.1$ kcal/kg is the enthalpy rise in the medium pressure steam.

Since q_1 and q_2 are fairly advanced in China, the oil replacement figure is very conservative.

The economics of the small heat and power co-generation nuclear plant is briefly described in the following:

(1) Heat and Power Costs

Based on the facts that the cost is 70 to 50 yuan per ton, the thermal value is 4,800 kcal/kg, the price of oil is 150 yuan per ton, and the fuel cost is estimated by assuming one-third of the total nuclear fuel loaded can operate at full capacity for 7,008 hours (load factor at 80 percent), the total costs and power generating costs of heat and power co-generation nuclear plants at various capacities are shown in Table 3. We can see that only when the price of high grade is reduced to 50 yuan per ton that it is equivalent to nuclear power. Considering the fact that the price of uranium is falling and the cost of coal is rising, it is more economical to run a nuclear plant.

Table 3. Comparison of Costs of Three Types of Heat and Power Co-Generation Plants (at 450 x 2 MW Thermal Power)

Item	Nuclear plant	Coal plant		Oil plant
		70 yuan/t	50 yuan/t	
Total cost, 10 ⁴ yuan/a	7,978	10,309	7,976.4	9,583
Fuel, 10 ⁴ yuan/a	3,610	6,064	4,331.4	7,674
Basic depreciation, 10 ⁴ yuan/a	2,563	1,955	1,955	794
Maintenance, 10 ⁴ yuan/a	905	690	690	395
Other expenses, 10 ⁴ yuan/a	900	1,000	1,000	720
Heat cost, yuan/10 ⁶ kcal	17	17	17	17
Power cost, cents/kWh	2.42 (gross) 2.83 (net)	5.34 6.24	2.416 2.83	4.43 5.20

(2) Return of Capital

Production cost per year is 7.98×10^7 yuan. It replaces 5.15×10^5 tons of oil. Based on the price of high grade oil, it corresponds to 2.37×10^8 yuan. The difference is 1.57×10^8 yuan.

(3) Thermal Efficiency

The thermal efficiency of a large nuclear plant is approximately 33 percent. The thermal efficiency of this plant is 80 percent.

In conclusion, the small heat and power co-generation nuclear plant is economically viable.

VI. Characteristic and Prospect of the Plan

(1) The reactor is a self-stabilizing integrated pressurized-water reactor.

(2) The reactor operates at low pressure, low core power density and low fuel temperature. The primary loop operates at a high mean temperature. Thus, it is possible to ensure safety and economical steam parameters. Under the condition that the pressure in the primary loop is 10 MPa, the steam in the tertiary loop can reach 4 MPa. The thermal efficiency is approximately 80 percent.

(3) A water-water-steam process is employed to improve the reliability of the heat exchangers in the reactor. In addition, the pressure in the secondary loop is higher than that in the primary loop to prevent radioactivity in the primary loop from leaking into the tertiary loop. The heat exchange for a water-water-steam system is better than that for a water-steam-steam system. It also reduces the size of the evaporators and the associated plant building.

(4) The reactor and the primary loop are integrated. The inner diameter of the safety containment is only 16 m. Thus, the reactor building is reduced to a minimum. The nuclear island is only 2,518 m² in area, which is 33 percent of that in a scattered design.

(5) Because of the small building size, the amount of cement and steel required is greatly reduced. Consequently, the construction cost is reduced by 200 million yuan. It replaces over 500,000 tons of oil per year. It is expected that the capital can be returned in approximately 6 years.

(6) The system is inherently safe and reliable. Because approximately 15 percent of the heat can be carried out by the natural circulation of the coolant after the main pumps are shut off, core melt-down will not occur due to loss of power. The intermediate loop is a high pressure water loop which makes it difficult for radiation to leak into the tertiary loop. The system is simple and the number of valves and pumps is significantly reduced. Therefore, it is less probable to have an incident. It uses water-water heat exchangers in the reactor which are more reliable than steam generators. All these factors can decrease the number of unplanned shutdowns.

(7) Due to its inherent high safety, it is possible to build it near a city or a large industrial site with a double layer safety shell.

(8) The reactor and the primary loop can be manufactured and assembled at the factory. The amount of work involved in on-site installation, welding, and testing is less. The scale of the construction of the safety shell and the nuclear and non-nuclear islands is relatively small. It only takes 5 years to complete a twin reactor plant.

(9) The shape of the plant buildings is simple and easy to build. The construction cycle is reduced.

Table 4 compares the major specification of an integrated reactor to those of a circulation type pressurized water reactor. The data in the table demonstrate that the design can meet the basic requirements of the nuclear plant.

In conclusion, a small heat and power co-generation nuclear plant is economically competitive. Based on the requirements of more than 20 potential steam users, it is more appropriate to build 400-600 MW reactors.

Table 4. Comparison of Major Performance Characteristics

No	Item		Integrated design	Scattered layout
1	Reactor power	MW	450 x 2	450 x 2
2	Steam generated	t/h	75 x 2 (medium pressure) 320 x 2 (low pressure)	75 x 2 (medium pressure) 320 x 2 (low pressure)
3	Power generated	kW	56947 x 2	52000 x 2
4	Thermal efficiency	%	- 80	79.15
5	Load factor	%	80	70
6	Oil replacement	10 ⁴ yuan/a	51.455	43.6
7	Primary loop operating pressure	MPa	10	15
8	Safety shell id/od	m/m	16/20	29/33.30
9	Nuclear island area	m ²	2,518	7,884
10	Nuclear island construction area/volume	m ² /m ³	20,000/140,000	23,320/353,185
11	Regular island area	m ²	6,000	8,522.7
12	Regular island construction area/volume	m ² /m ³	22,800/190,000	31,728/229,808
13	Total investment	10 ⁸ yuan	6.80	8.80
14	Construction cycle	a	5	6-7
15	Worst incident		drain pipe (ϕ 50) fracture	main pipe (ϕ 510) fracture

A heat and power co-generation nuclear plant should focus on heat. The amount of power generated is determined by the heat requirement. Power generation should not be very high in proportion to avoid the high cost of steam turbines. If heat is primary and power is secondary, it is more appropriate to adopt a water-water steam flow process. In the choice of reactor, either pressurized and boiling water reactors may be used. However, a pressurized water reactor should be preferred in order to raise

the temperature to produce steam in the tertiary loop for heating. An integrated layout and forced circulation should be adopted for the reactor and the primary loop. This is more compact than a natural circulation boiling water reactor. Figure 12 shows a 640 MW self-stabilizing pressurized reactor. The inner diameter of the pressure shell is 4.5 m, the total height is 16 m and the total weight is approximately 320 tons. A natural circulation boiling water reactor (with heat exchangers inside the reactor) with a comparable pressure shell is only around 450 MW. Based on the steam requirements of the chemical industries in China, the operating pressure of the reactor should be 10 MPa. Therefore, the following conclusions are derived.

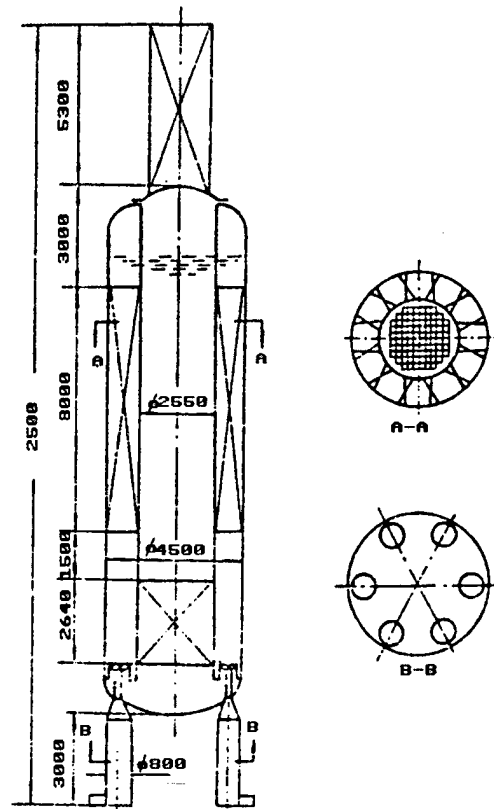

Figure 12. 640 MW Integrated Self-Stabilizing Pressurized-Water Reactor

An integrated, self-stabilizing, forced circulation pressurized-water reactor should be chosen for a small heat and power co-generation nuclear plant. The reactor operating pressure is 10 MPa. The power per reactor is 400-600 MW and the maximum power is 1,000 MW. The primary process is water-water-steam and the amount of power is determined by the steam demand. Boric acid is eliminated to simplify the system. This plan is also applicable to a small nuclear power plant. However, the heat exchangers in the reactor would be replaced by steam generators. If the steam-water separator is placed outside the reactor, then the schematic

diagram of the system becomes Figure 13. Under the condition that the structural dimensions and parameters remain unchanged, the secondary loop produces saturated steam at 44-60 atmospheric pressure.

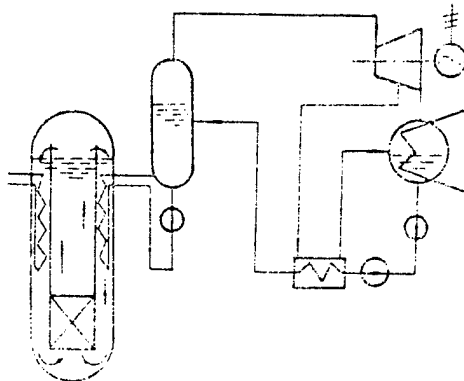

Figure 13. Schematic Diagram for a Nuclear Power Plant

This plan may also be applied to supply heat to cities and towns. With the same reactor and auxiliary system, it becomes a nuclear heat generating plant by reducing the operating pressure and the temperature and by replacing the steam generator with a heat exchanger in the tertiary loop. It does not require any additional study and experimentation.

Of course, this plan can also be used for seawater desalination and power generation. It only requires a modification of the flow process.

The advantages and disadvantages of natural and forced circulation will be investigated further. The driving mechanism of the control rods will be modified. The use of a high conversion ratio reactor in a small plant will also be investigated.

The basic investment for a small 200 MW nuclear plant can be controlled within 400 million yuan. It can be completed in 4 years. The majority of the equipment can be manufactured in China. Moreover, it can meet the basic requirements of heat and power co-generation and urban heating.

In summary, this type of a small heat and power co-generation nuclear plant can become an economical, safe, and clean energy source for cities and large industries in the future. Its initial investment is low, the constructing period is short, the range of applications is wide, and the prospect is bright. It should have a role in the development of energy resources in China.

12553/9365

Daya Bay Said on Schedule for Completion in 1992

40130062 Hong Kong ZHONGGUO TONGXUN SHE in Chinese 1404 GMT 9 Mar 88

[Report by Zhao Yuanguang [6392 6678 0342]: "Guangdong Nuclear Power Corporation Reiterates That the 'Daya Bay Power Plant' Will be Completed on Schedule"]

[Text] Shenzhen, 9 Mar (ZHONGGUO TONGXUN SHE)--The spokesman for the Guangdong Nuclear Power Joint Venture Corporation today reiterated that the first phase of the construction of the Daya Bay Nuclear Power Plant will be completed and put into operation in October 1992, as scheduled. He stated that all speculation concerning a delay in the project is groundless.

The spokesman told reporters that the initial stage of the foundation work on the Daya Bay Nuclear Power Plant was completed ahead of schedule. Therefore, he added, the incident of forgetting to embed some steel bars in the raft foundation of the reactor has not affected the original project schedule very much. We can gradually make up for the lost time. The original schedule for the Daya Bay Nuclear Power Plant project included much leeway, and the project can be completed as scheduled. The spokesman also pointed out that at present, all construction work is progressing and no problems have been encountered. The rumor that some technological problems remain unsolved in the Daya Bay Nuclear Power Plant project is sheer groundless conjecture.

Regarding the rumor that a delay in the completion of the project may increase the investment cost, the spokesman said that according to the contract, if the contractor causes any delays, he has to bear all expenses incurred and will be fined. Therefore, even if the Daya Bay Nuclear Power Plant project is not completed as scheduled, the burden on the investors would not be increased.

The spokesman said that last year, 60,000 m³ of concrete were poured in the Daya Bay Nuclear Power Plant project and that the No 1 Nuclear Island raft foundation, where the above mentioned incident occurred, is rising layer after layer. He said that to ensure the quality of the project, strict control is exercised over each process, from tying steel bars to inspecting them, and from quarrying to fitting, transportation, and concrete pouring.

The spokesman added that this year, the design, equipment installation, and civil engineering work of the Daya Bay Nuclear Power Plant project will enter a peak period. He said that a large quantity of civil engineering work, installation work, and preparation of relevant data and documents for the nuclear island, conventional island, and accessory equipment has to be completed. He also said that the nuclear island schedule shell and components of the nuclear reactor, the evaporator, the main pump, the manostat, and the major equipment for the convention island have to be manufactured.

This year, some 200,000 m³ of concrete are to be poured at the worksite; the steel lining and the concrete outer wall of the 57-m high No 1 Nuclear Island safety shell have to rise to a certain height above the ground; and corresponding progress is to be made in constructing the concrete structure of the turbine plant.

A number of operators will be sent to be trained in France at the beginning of next year after they have learned French and passed tests given by the French Electric Power Company this year.

/9365

Preparations Underway To Install Equipment at Qinshan

40100013 Beijing XINHUA in English 1145 GMT 26 Feb 88

[Excerpts] Beijing, 26 Feb (XINHUA)--The installation of equipment in China's first nuclear project plant at Qinshan in Zhejiang Province will start soon following the completion of the reactor schedule vessel in early March.

Nuclear Industry Minister Jiang Xinxiong told a meeting which opened here Thursday that his ministry has given priority to the development of nuclear energy and construction of nuclear project stations in its shift from military to civilian use.

He said that scientists, after re-examination, have confirmed that the welding and concrete work of the vessel are up to the design standards. Also, the manufacture of fuel components and equipment, as well as the operation preparations are now underway.

It is expected that the Qinshan Nuclear Power Plant will go into operation in 1990.

The civil engineering work of the Guangdong Nuclear Power Plant at Daya Bay, a joint venture, began last August and the construction of the nuclear and conventional islands there will be in full swing later this year, the minister said.

In addition, the government has approved the second-stage project for two 600,000 kW reactors added to the Qinshan plant, and the preconstruction work is now also underway.

He said nuclear technology is playing an important role in the oil and mining industries.

Efforts will be devoted to raising the quality of civil engineering work and safety control at the two nuclear power plants now under construction, the minister added.

The ministry will carry out the primary design for the second-stage project of the Qinshan Nuclear Power Plant and complete a feasibility study this year, the minister said.

/9365

END

10

This is a U.S. Government publication. Its contents in no way represent the policies, views, or attitudes of the U.S. Government. Users of this publication may cite FBIS or JPRS provided they do so in a manner clearly identifying them as the secondary source.

Foreign Broadcast Information Service (FBIS) and Joint Publications Research Service (JPRS) publications contain political, economic, military, and sociological news, commentary, and other information, as well as scientific and technical data and reports. All information has been obtained from foreign radio and television broadcasts, news agency transmissions, newspapers, books, and periodicals. Items generally are processed from the first or best available source; it should not be inferred that they have been disseminated only in the medium, in the language, or to the area indicated. Items from foreign language sources are translated. Those from English-language sources are transcribed, with the original phrasing and other characteristics retained.

Headlines, editorial reports, and material enclosed in brackets [] are supplied by FBIS/JPRS. Processing indicators such as [Text] or [Excerpts] in the first line of each item indicate how the information was processed from the original. Unfamiliar names which are rendered phonetically or transliterated by FBIS/JPRS are enclosed in parentheses. Words or names preceded by a question mark and enclosed in parentheses were not clear from the original source but have been supplied as appropriate to the context. Other unattributed parenthetical notes within the body of an item originate with the source. Times within items are as given by the source.

SUBSCRIPTION/PROCUREMENT INFORMATION

The FBIS DAILY REPORT contains current news and information and is published Monday through Friday in 8 volumes: China, East Europe, Soviet Union, East Asia, Near East & South Asia, Africa (Sub-Sahara), Latin America, and West Europe. Supplements to the DAILY REPORTs may also be available periodically and will be distributed to regular DAILY REPORT subscribers. JPRS publications generally contain less time-sensitive information and are published periodically. Current JPRS publications are listed in *Government Reports Announcements* issued semi-monthly by the National Technical Information Service (NTIS), 5285 Port Royal Road, Springfield, Virginia 22161 and the *Monthly Catalog of U.S. Government Publications* issued by the Superintendent of Documents, U.S. Government Printing Office, Washington, D.C. 20402.

U.S. Government offices may obtain subscriptions to the DAILY REPORTs or JPRS publications (hardcovers or microfiche) at no charge through their sponsoring organizations. DOD consumers are required to submit requests through appropriate

command validation channels to DIA, RTS-2C, Washington, D.C. 20301. (Telephone: (202) 373-3771, Autovon: 243-3771.) For additional information or assistance, call FBIS, (703) 527-2368, or write to P.O. Box 2604, Washington, D.C. 20013.

The public may subscribe to either hardcover or microfiche versions of the DAILY REPORTs and JPRS publications through NTIS at the above address or by calling (703) 487-4630. Subscription rates will be provided by NTIS upon request. Subscriptions are available outside the United States from NTIS or appointed foreign dealers. Back issues or single copies of the DAILY REPORTs and JPRS publications are not available. New subscribers should expect a 30-day delay in receipt of the first issue.

Both the DAILY REPORTs and the JPRS publications are on file for public reference at the Library of Congress and at many Federal Depository Libraries. Reference copies may also be seen at many public and university libraries throughout the United States.