

224063

JPRS-JST-88-012

12 JULY 1988

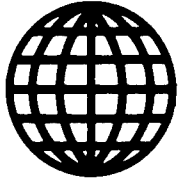

**FOREIGN
BROADCAST
INFORMATION
SERVICE**

JPRS Report

DISTRIBUTION STATEMENT A
Approved for public release;
Distribution Unlimited

Science & Technology

Japan

MANNED SPACEFLIGHT TECHNOLOGY
SYMPOSIUM

19980612 044

REPRODUCED BY
U.S. DEPARTMENT OF COMMERCE
National Technical Information Service
SPRINGFIELD, VA. 22161

DTIC QUALITY INSPECTED 6

10
44
A03

JPRS-JST-88-012

12 JULY 1988

SCIENCE & TECHNOLOGY

JAPAN

MANNED SPACEFLIGHT TECHNOLOGY SYMPOSIUM

Tokyo DAI SANKAI YUJIN UCHU HIKO GIJUTSU Symposium KOENSHU in Japanese
21-22 Jan 88

CONTENTS

OXYGEN ATOMS, SPACE DEBRIS REPORTED.....	1
SPACE, SOLAR HEAT RADIATION DISCUSSED.....	7
LIFE SUPPORT, ENVIRONMENTAL CONTROL SYSTEMS DESCRIBED.....	15
SPACE WATER PROCESSING, GAS REPROCESSING TECHNOLOGY DISCUSSED.....	23
MAN/MACHINE WORKLOAD SHARING IN JEM DESCRIBED.....	30
RADIATION EFFECTS DISCUSSED.....	35

Oxygen Atoms, Space Debris Reported

43062567a Tokyo DAI SANKAI YUJIN UCHU HIKO GIJUTSU Symposium KOENSHU in Japanese 21-22 Jan 88 pp 2-5

[Article by Yoshinori Fujimori, et al.]

[Text] 1. Introduction

The effects of oxygen atoms on materials at the altitude of the space shuttle and space station orbits and the danger of collision of space meteorites and artificial debris with a spaceship and space station are not interrelated at all in terms of a scientific area, so it is naturally impossible to discuss these subjects together in this paper. These issues have been brought to the fore by the flight experience of the space shuttle and the imminent long stay by a space station and, although researchers and engineers have been aware of these issues, no full-fledged technology worthy of attention has been developed in the design. These problems have been tackled as research themes in the United States, but remain unexplored areas in Japan, and most of the relevant information comes in the form of literature. It is not that relevant research papers do not currently exist at all in Japan. However, since it was considered important, the author, who has made no close inquiries into these problems, is taking it upon himself to comment on them.

The effects of atomic oxygen are thought to range from changes and deterioration in materials' surface properties and degradation of the surface, i.e., declines in structural functions caused by erosion, to rupture, with long-range effects still a matter of conjecture. Therefore, we are not in a position to assure the quality of space structures against these effects. Although Japan is going to participate in the space station project as part of international cooperation, it is not yet prepared to cope with this on its own.

Concerning the breakage of space structures due to collisions with meteorites and debris, no standards whatsoever exist in regard to the premises for estimation, i.e. how to estimate the probability of collision and how to estimate the probability of breakage due to collision. With respect to the structural resistance against these, we cannot but analogize from the results of experiments conducted so far in the United States, and are far from guaranteeing the quality.

Since the design capabilities of Japan are not sufficient in respect to this group of problems, the United States, with the heavier responsibility involving the entire system, is expected to indicate unified views and technical guidelines in regard to the project facing us, e.g., those involving the space station, as part of international cooperation. However, since long-term "reliance upon others" is detrimental to the independence of Japan in regard to technical foundations, it goes without saying that Japan must conduct fundamental research. In view of their nature, the theory and principle of these problems are self-explanatory. However, even if they are incorporated in design, there is no way of putting them to practical use, since we lack the experimental methods and equipment for verification; and, since we also lack the software for prediction, there is no way of assuring quality. Therefore, even if these problems have not been completely solved, we shall have to design, manufacture, and operate a space system, although we are aware of some risks of contingency. Nevertheless, it is a matter of course that we make efforts to make a safer system feasible under the present human and material environmental conditions and, in this context, we ask for the understanding and concern of the populace at large.

2. Effect of Atomic Oxygen (1)

The composition of the atmosphere is shown in Figure 1. At the altitude of STS flight, the atomic oxygen concentration is the highest. At an altitude of about 500 km during the orbit of a space station, the concentration of atomic oxygen is also at its height. At an altitude of about 200 km in the thermosphere, the concentration of nitrous molecules becomes lower than that of atomic oxygen. It was observed in the STS-1-4 that this relatively high concentration of oxygen atoms was a cause of problems--the discoloration of blankets, a rapid change in paints with the passage of time, the degradation of blanket surfaces and changes in the electric resistance of surfaces were reported. It was also reported that some things became fluorescent during the flight. It is generally known that exposure tests (40 hours) were conducted for a week on samples of various materials in the STS-5,8 to examine these problems closely. In space, effects of high vacuum, ultraviolet rays, radiation rays and thermal cycles, in addition to those of oxygen atoms, are observed, but their combined effects with oxygen atoms are unknown. It is "assumed" that the effects of atomic oxygen on material deterioration are probably quite substantial. The primary parameter in the assessment of these effects is the concentration or the amount of atomic oxygen, and the number of atoms flowing into the unit surface area is defined as the total quantity of flow by integration within the exposure time. In this case, the total flow is calculated on the assumption that the orbital speed is constant if the orbit is the same, and the orbit would be changed if the speed should fluctuate. Although the concentration of atomic oxygen changes with sunshine/shade, season and changes in solar activities, etc., the effects of changes in solar activities are great. The direction of a part of a structure toward a velocity vector is important, and a "ram" direction surface is the greatest. The thickness of the degraded surface is obtained by multiplying this total flow by the reaction efficiency inherent in the

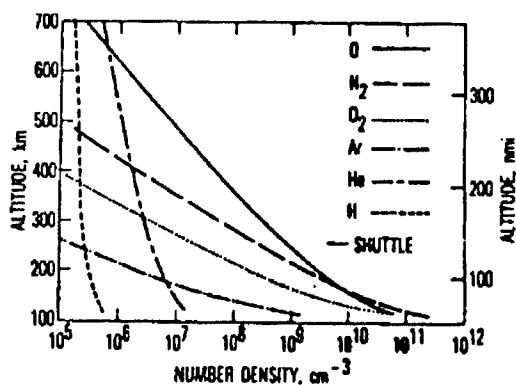

Figure 1. Composition of the Atmosphere in Low Earth Orbit (the thermosphere)

materials. This reaction efficiency has been calculated for the main organic materials from flight experiments by the STS-8. The reaction efficiency of kapton and polyethylene is high, but that of teflon is low. The level of epoxy is about two-thirds that of kapton.² See Table 1.

Table 1. Reaction Efficiency

Material	Reaction efficiency cm ³ /atom x 10 ⁻³⁴
Kapton	3.0
Mylar	3.4
Tedlar	3.2
Polyethylene	3.7
PMMA*	3.1
Polyimide	3.3
Polysulfone	2.4
1034C epoxy	2.1
5208/T300 epoxy	2.6
Teflon, TFE	<0.05
Teflon, FEP	<0.05

*PMMA is polymethylmethacrylate.

In this regard, an important task involves the equipment and facilities for assessment on the ground. Since we cannot rely on flight tests by STS alone, simulators and space chambers on the ground are indispensable in order to conduct experimental research on the durability of structural materials and their surfaces and develop new materials.

In order to obtain oxygen atoms, it is just necessary to dissociate oxygen molecules in some way and put them in a vacuum chamber, but this is a fairly difficult job technically speaking. The method now under consideration is to employ: 1) heat and electric discharge; 2) lasers; and 3) microwaves or 4) the acceleration and neutralization of oxygen

ions. In addition, there are many other problems awaiting solution such as the measurement of the ratios of oxygen molecules and oxygen atoms obtained in the atmosphere, the formation of beams, and the control of energy levels.

We have heard that there is an enterprise in the United States offering, on a commercial basis, the ground equipment needed for experiments as well as the experimental experience gained by using it. However, unless an independent research system is set up in Japan and the necessary experimental facilities installed, we shall be dealing with a "black box" in terms of technology.

3. Space Meteorites and Artificial Debris^{7,8}

A meteorite consists of natural rock or frozen earth and sand. Its weight ranges from 0.1 g, for a granular material, to more than several thousand tons. It is presumed from surveys that small meteorites are dominant in number while big ones are few, and the distribution of standard ones is shown as data.⁹

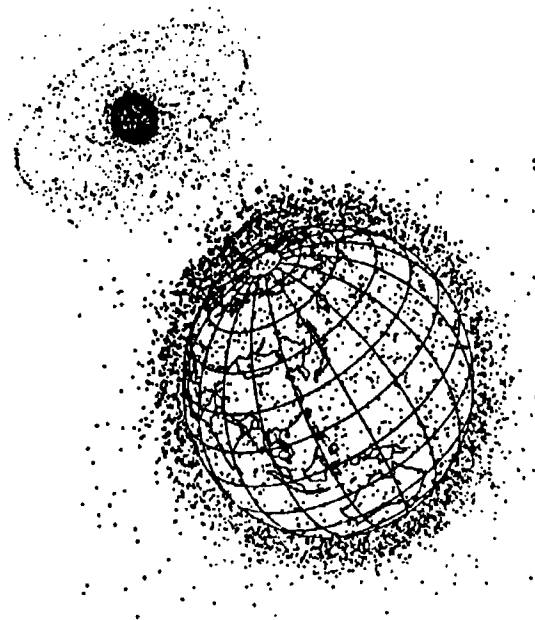

Figure 2. Bird's-Eye View of Debris Distribution
View of the earth and vicinity from a distance
(upper photo)
"Lost articles" in space being traced by the
United States number about 7,000 (sketch drawn
using a computer by Teledyne Brown Engineering
for the ASAHI SHIMBUN) (lower photo)

Man-made debris includes the products from human space activities and, so to speak, parting presents left behind on orbits, and is increasing year by year. It is assumed that large ones are upper parts of rockets and

artificial satellites which either failed to go into orbit or completed their spans, while small ones include clamp bands, bolts, nuts, cables, etc. In addition, there may be fragments created by intentional or accidental explosions and collisions. The debris which can be traced from the ground is plotted in Figure 2. This is from an article published in the ASAHI SHIMBUN, which qualitatively shows the crowding of debris around the earth. From a distance, debris near stationary orbits can be seen clearly and, if the present rate of increase continues, the earth may soon become a planet with a circular ring similar to Saturn.

Important matters include to what extent the amount of debris will increase and how to handle such small objects as cannot be identified by the present detection devices. There is currently no answer for these matters, so we have to proceed on the basis of assumption. The detection of objects smaller than 1 cm is predicted to take a long time.

Mass, diameter (distance across), and velocity are used as the parameters of destructive power for both meteorites and man-made debris. While for the former the distribution of velocity and its average represents 20 km/sec, the low orbit velocity of the latter is 7-8 km/sec. If the latitude increases, this velocity decreases a little. A particle with a mass of 0.1-0.2 g has extremely destructive power in this velocity and the normal construction of aircraft and rockets will never be able to protect against them. According to past experiments in the United States, it is good to at least double the wall. If concern still exists, the wall strength may be trebled or quadrupled. Although increasing a parameter results in increasing the work when designing a shielding structure, the safety of the system comes first. Even if tests are conducted, a group of interrelated questions will arise involving what structural parameters should be set up and how to determine the probability of particles dashing this way and what parameters (including the mass and velocity of a particle) should be used for verifying tests, etc.

In order to study structural resistance to these various flying objects, it is indispensable that simulators be installed on the ground. Among other things, a particle launcher is the key. In Japan, research is being conducted on a launcher capable of generating a speed of 10 km/sec,^{10,11,12} and it should satisfy many requirements enabling it to be used for verifying structural tests. For instance, it can: 1) control the velocity of particles; 2) repeat launching; 3) at an interval of 2-3 hours; 4) change the weight of particles up to a maximum of 1 gram; and 5) generate a maximum launching speed of 30 km/sec and, on the whole, ensure the safety of a system.

4. Conclusion

A voluntary study meeting is being held in Kogiken to deal with the problems involving atomic oxygen, meteorites, and man-made debris, and to scrutinize the relevant technologies. Tasks taken up there are quite informal and the study is not expected to bear fruit in the short run. Therefore, long-term research strategies are required. Since it is too late to tackle problems after they came to the fore, we would like to make

some proposals regarding the simulators necessary for ground research and a simulator system to certify the tests, and approach the particles concerned to encourage them to have them approved.

I thank the National Space Development Agency of Japan, Mitsubishi Electric Corp., Mitsubishi Heavy Industries, Ltd., Nissho Iwai Corp., and Marubeni Corp. for their cooperation in providing information and data.

References

1. Ishikawa, "Survey of the Effects of Atomic Oxygen," draft report (under preparation) on NAL/HASDA joint research results, June 1987.
2. L.J. Leger and J.T. Visentine, "Protecting Spacecraft From Atomic Oxygen," A/A July 1986.
3. NASA CP-2340, 13th Space Simulation Conference.
4. AIAA J. Vol 24, No 4, 1986.
5. AIAA J. Vol 25, No 11, 1987.
6. J. OF AIRCRAFT, Vol 24 No 5, 1986
7. NAL TM-572.
8. Survey of Collision and Fall of Flying Objects in Space, Miraiken, 1985.
9. SS Program Dev. & Req. JSC 30000 Section 3,^{10,11,12} refer to research being conducted at Tokyo Institute of Technology, Agency of Industrial Science and Technology, National Aerospace Lab., and "Hazard Technology Symposium Data (1)."

20110/9365

Space, Solar Heat Radiation Discussed

43062567b Tokyo DAI SANKAI YUJIN UCHU HIKO GIJUTSU Symposium KOENSHU in Japanese 21-22 Jan 88 pp 6-9

[Article by Katsuhisa Furuura and Tamiko Iwasaki]

[Text] Space Radiation

Space radiation is roughly classified into galaxy radiation constantly emitted from the Milky Way, solar radiation accompanying solar flares, and trapped radiation in the geomagnetic fields. The radiation mostly consists of high energy (\geq MeV) protons and electrons, but baryons, such as α and HZE particles, cannot be neglected. Research has been conducted, mainly in the United States and the Soviet Union which have experience with manned space flight, on observed data, including corpuscular flux and the energy spectrum, environmental models, and the analysis of radiation through their use, and the effects of radiation on living bodies and electronic equipment, including related protective measures.

The main space radiation differs with flight missions and, since we are concerned at the moment with circumterrestrial orbits, trapped and solar radiation are important. The flux of trapped electrons and protons (0.5 MeV) is more than $10^8/\text{cm}^2 \text{ sec}$. While galaxy radiation has high energy particles of 10^{11} GeV, the corpuscular flux ($\sim 5/\text{cm}^2$) is small. Although the available environmental models are in good agreement with measured data at the points of observation, the data observed fluctuate hourly and locally due to magnetic storms and solar flares, showing particularly great fluctuations at high altitudes. The radiation belt is changing on a broad front, so continued correction of environmental models is necessary. Since a solar flare is a probable phenomenon and the fluctuations of solar radiation accompanying it and trapped radiation affected by it in terms of time and space are great, solar radiation is analyzed on the basis of probability. The proton flux and energy spectrum (an overall proton flux of more than 30 MeV reaches $10^{10}/\text{cm}^2$) of the large-scale solar flares which occurred in November 1960 and August 1972 are often used for the solar radiation model.

Radiation Dose

The corpuscular flux dose and radiation dose along a mission orbit can be estimated by using the environmental models of the corpuscular flux and energy spectrum. In calculating the radiation dose, the effects of energy loss (electrolytic dissociation and excitation) and scattering inside the shield substances of incident high energy particles are estimated (the Monte Carlo method is effective for complex shapes). The corpuscular flux and energy spectrum in every part of a spacecraft (human body) are converted into a radiation dose. The rad is generally used as the unit of the radiation dose. When an irradiated substance of 1 g absorbs an energy of 100 erg from radiation, the quantity of rays it has received (quantity of rays absorbed) equals 1 rad. For protection against radiation, a dose equivalent is used in studying the effects of radiation on living bodies. The value of the dose equivalent (rem) can be obtained by multiplying the value of the dose (rad) absorbed by the organ in question by the quality factor of radiation (Table 1).

Table 1. Quality Factor

Primary radiation	Quality factor
X-ray, γ -ray, β -ray, electron beam	1
Neutron (10^{-2} - 10^3 MeV)	2 - 11
Proton (2×10^0 - 3×10^3 MeV)	1.4 - 2
Neutron with unknown energy, proton and particle of 1 electric charge larger than 1 u in resting mass	10
α particle with unknown energy, particle with multiple electric charge, particle with unknown electric charge	20

Nomographs of dose rates for trapped protons and electrons at the center of a spherical aluminum shield in a circular orbit (inclination angle of 30°) are cited respectively in Figures 1 and 2. Standard values for an aluminum shield for the case of emphasis being placed on a space suit, normal flying body or shield would be 0.5 g/cm^2 , $1-2 \text{ g/cm}^2$, and 4 g/cm^2 , respectively. Figure 3 compares doses confronted by human eyes in a six-passenger space station model (altitude of 200 nmi, inclination angle of 90°). Assuming the one-time occurrence of a solar flare, the solar radiation model of November 1960 is used. The main radiation differs with the shield thickness.

Radiation Injuries

The effects of radiation can be divided into bodily harm to the man exposed and the genetic damage affecting his descendants. The physical harm appears several weeks after exposure or shows its symptoms several years or several decades later (see Table 2). Physical symptoms and doses

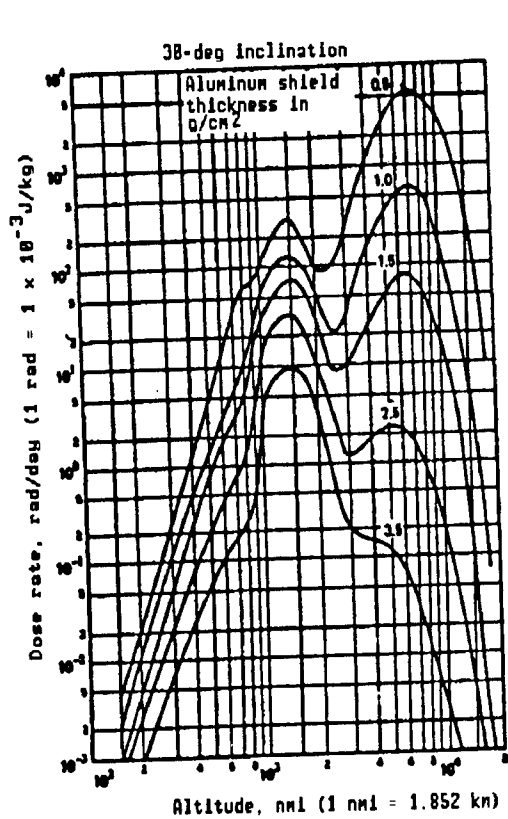

Figure 1. Trapped Proton Dose

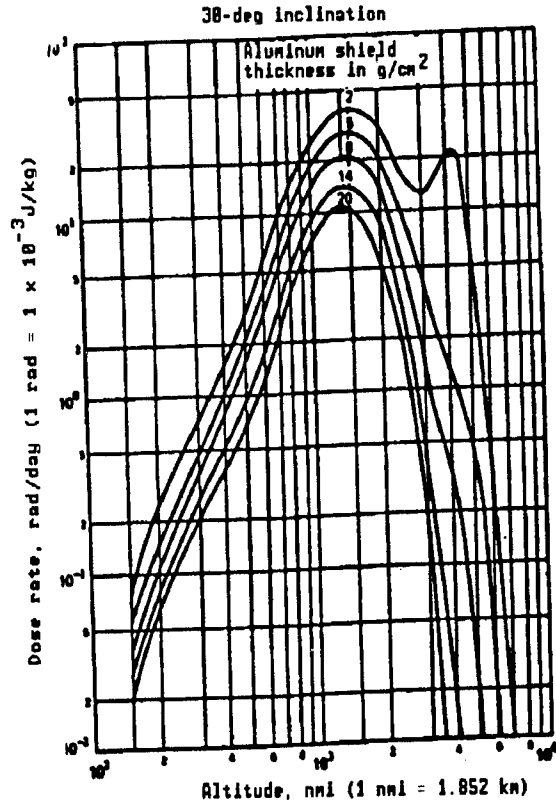

Figure 2. Trapped Electron Dose

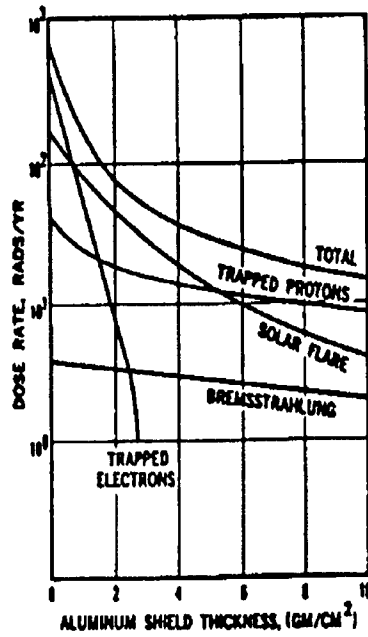
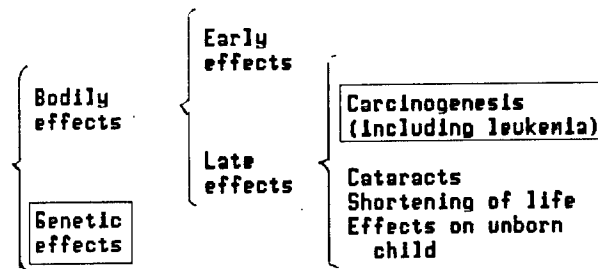

Figure 3. Comparison of Doses Inflicted on Eyes

Table 2. Classification of Radiation Injuries



sufficient to cause them are roughly indicated in Table 3. While a large dose is necessary to cause the early outbreak of injuries, a small dose (lower than 25-50 rad) is questionable in its connection to injuries occurring later, such as carcinogenesis and genetic damage, as seen from the table. From the standpoint of radiation protection, the International Commission on Radiological Protection (ICPR) classifies these injuries into improbable effects with threshold value and probable effects with no threshold value, with probable effects enclosed in brackets in Table 2.

Table 3. Relationship Between Systemic Exposure Dose and Physical Symptoms (effects)

Dose (rem)	Effect
5-25	Minimum dosage allowing a change to be detected through chromosomal analysis (or another specialized test) (no change in hemogram)
50-75	Minimum dosage permitting change to be detected in individual
75-125	Minimum dosage possibly causing nausea in about 10 percent of people exposed
150	Decline in procreative power for very short period
150-200	Causes hair to fall out. Dosage that may cause most people exposed to experience a primary feeling of powerlessness and an apparent change in hemogram (acute exposure)
250	Temporary sterility for 1-2 years
300	50-percent fatal dose (acute exposure for short period)
500	Permanent sterility
700	100-percent fatal dose

Radiological Protective Standards

The object of radiation protection is to prevent the occurrence of unlikely harmful effects and to limit the probability of probable effects to a permissible level. This basic stance should be maintained for radiation protection in space flights. Radiation protection standards in most countries are based on ICRP recommendations, but their application differs from country to country. Most countries are presently working on legislation in accordance with the ICRP recommendations issued in 1977, and a new dosage restriction system is expected to be enacted in Japan this year or next. For purposes of comparison, the current permissible exposure doses in Japan and the ICRP recommendations of 1977 are shown, respectively, in Tables 4 and 5.

Table 4. Permissible Exposure Dosage Based on Injury Prevention Law (Current)

	Person handling radiation	Occasional visitors and workers entering controlled area
Maximum permissible exposure dosage	(1) 3 rem per 3 months (except for those listed in Items (2) and (3))	1.5 rem/year
	Whole body (2) Woman of child-bearing age: 1.3 rem/3 months	
	(3) Pregnant woman: 1 rem during period from day pregnancy confirmed to delivery	
	Skin only 3 rem/3 months	3 rem/year
	Hand, arm, and foot or leg joint only 20 rem/3 months	--
Maximum permissible cumulative dosage (D)	$D = 5 (N - 18) \text{ rem}$ N: age	--
Permissible exposure dosage during emergency operation	12 rem (male only)	

Table 5. Dosage Limits for Individuals According to 1977 ICRP Recommendations

	Portion	Operator	General public
Probable effects	Whole body (main parts of system)	5 rem/year	0.5 rem/year
Improbable effects	Crystalline lens	15 rem/year	--
	Anatomy other than crystalline lens	50 rem/year	5 rem/year

Note: 0.1 rem/year was recommended in ICRP statement in Paris (1985)

ICRP estimates the mortal probability of cancer caused by systemic exposure of 1 rem to be 1.25×10^{-4} with, for example, the occupational risks of a man handling radiation for 40 years being $1.25 \times 10^{-4} \times 5 \text{ rem} \times 40 \text{ years} = 2.5 \times 10^{-2}$, that is, 2.5 percent (it is known, however, that 1/10 of the annual dose limit is not exceeded). The probable effects (the occupational risks of mortal cancer are assumed at 3 percent) proposed by the United States in space flights and the recommended values of improbable effects are shown in Tables 6 and 7, but these values must be examined further.

Table 6. Occupational Limits (rem) (Probable effects)*

Excessive occupational risks of mortal cancer	Age	25	35	45	55
	3×10^{-2}	Male	150	250	325
3×10^{-2}	Female	100	175	250	300

*Exposure for 10 years

Table 7. Recommended Values of Dose Equivalent Limits (rem) (Improbable effects)

	Blood-producing organ	Eye	Skin	Gonad
Career	100-400	400	600	150
Annual	50	200	300	50
30 days	25	100	150	25

How much these risks increase during actual space flights and to what extent they are permissible for astronauts to be exposed to are controversial questions.

Space Radiation Protection

In the case of orbiting at a low altitude (200 nmi) for half a year, corresponding to Figure 3, if the dosage limit for eyes is specified as

100 rem (Table 7) and 50 rad against protons, for example, since this dosage represents 100 rad a year, an aluminum shield of 2 g/cm² is required. As shown in Figures 1 and 2, trapped radiation suddenly increases as altitude increases (20,000 km). Since heavy ionic particles, known as HZE particles (high-z-energy particles), release large amounts of energy along a track, their quality factors are high and the possibility exists of causing substantial local (retina and cell) injuries. Therefore, space radiation becomes a serious problem in lengthy manned flights at high altitudes. It is believed urgent to develop not only a passive shield, e.g., a multilayer shield [polyethylene (CH₂) is effective against protons and lead against bremsstrahlung (soft X-rays)], but also a positive shield, e.g., a magnetic field shield using high temperature superconductivity, which has recently drawn public attention, or a plasma shield.

Solar Heat Radiation

The sun radiates electromagnetic waves constantly, including electric wave bands, ultrared rays, visible rays, ultraviolet rays, and X-γ rays, with most of the solar radiation energy contained in the field of visible rays equivalent to a blackbody radiation of 5,760 K. Although less dangerous than space radiation, solar radiation is important due to its effect on the deterioration of materials following irradiation from long periods, human bodies during activities inside and outside a spacecraft and the adjustment of temperature of equipment and appliances. It is also necessary to take into consideration direct solar heat radiation (solar constant: 1,353 W/m²), the reflection (albedo: 0-600 W/m²) earth, which decreases according to an increase in altitude, and earth heat radiation (9-400 W/m²).

Conclusion

Injuries to human bodies caused by space radiation during manned space flights in EVA in particular are a serious problem, so it is imperative that Japan begin work immediately on methods to estimate and protect against radiation doses for every flight mission. Items believed to be short-range tasks are given below (in the long run it may be necessary for Japan to implement her own basic research and develop new technology):

- (1) The collection and examination (the establishment of an information center) of observed data (data base), such as corpuscular flux, energy spectrum, etc.
- (2) The examination and verification (experiment) of a method to analyze space radiation doses.
- (3) The examination and verification (experiment) of a method to protect against space radiation.
- (4) The examination and verification (observation) of methods to measure space radiation and to observe and predict solar flares.

(5) Survey and research the effects of space radiation on living bodies and establish standards for permissible doses.

Acknowledgement

We would like to express sincere thanks, by noting here that we are indebted to members of the Ultrahigh Flight Suit Research Society for many useful pieces of information involving EVA.

20110/9365

Life Support, Environmental Control Systems Described

43062568a Tokyo DAI SANKAI YUJIN UCHU HIKO GIJUTSU Symposium KOENSHU in Japanese 21-22 Jan 88 pp 10-13

[Article by Kuniaki Shiraki and Takashi Manabe]

[Text] 1. Introduction

Manned space systems, such as the space shuttle and space station, are aimed at expanding manned space activities and diversifying and upgrading space environment utilization. An important system indispensable for the development of the manned space system is the life support system for the crew. Under the present manned space system, the environment control/life system (ECLSS), designed mainly to control the pressurized air environment in which the crew stays, supports manned space activities.

This article will describe the role of ECLSS in a manned space system and outline the most advanced ECLSS of the American space station (SS) project. Additionally, the present status of the ECLSS design of the Japanese experimental module (JEM) to be mounted on the SS now under study in Japan and relevant technological tasks will be reported.

2. Environment Control/Life Support System (ECLSS)

The ECLSS of a manned space system provides a comfortable pressurized environment for the crew, who consequently need no special suits, and ensures the crew's safety.

The ECLSS, therefore, is required to possess the basic functions shown in Table 1 to control the air environment, such as the air composition (pressure, O₂ partial pressure, CO₂ partial pressure), the concentration of harmful gases, temperature, humidity and air velocity/flow, and to manage water and food.

How these functions were achieved, by what performance, on what scale, and by what system construction is determined by the following:

- o The number of crew members, the scale of the pressurized environment (cubage) and resources (electric power)

Table 1. Basic Life Support System Functions

Basic function	Object for application	Control/management
O ₂ supply	Crew's metabolism, structural leakage, use of air lock	O ₂ partial pressure
N ₂ supply	Structural leakage, use of air lock, machine driving	Total pressure (N ₂ /O ₂ ratio)
Elimination of CO ₂	Crew's metabolism	CO ₂ partial pressure
Elimination of hazardous gas and offensive smells	Crew's metabolism, machinery/material off-gas	Concentration of hazardous gas
Elimination of fine particles/micro-organisms	Crew, machinery, materials, waste, draining	Number of fine particles/micro-organisms
Elimination of moisture	Crew's metabolism, evaporation of water used	Dew point (humidity)
Elimination of heat	Crew's metabolic heat, heat generated by machines, structural heat	Temperature
Air circulation	Cooling of crew and machinery, early environment measurement, fire detection	Air velocity/flow
Water supply	Drinking, food preparation, bath, dish washing, hand-washing, other washing	Quality and temperature of water
Food supply	Consumption by crew	--
Crew support	Dwelling, life, health control, experimental work, emergency	--

- o Supply capability/duration, operation costs
- o The object of the manned space mission (place, term, scope of crew's activities, etc.)
- o Safety and reliability

3. Environment Control/Life Support System of American Manned Space Station (SS/ECLSS)

The SS/ECLSS provides a pressurized air environment controlled to the environmental control levels shown in Table 2 for an eight-man crew in the pressurized module component of the SS. In constructing the system it is necessary to adopt air and water recycling systems aimed at maximizing the supply volume by developing the nonrecovery, nonreprocessing, recovery, and nonrecycling systems of the skylab, spacelab, and space shuttle. As a result, only N₂ gas has to be supplied constantly to ECLSS.

Table 2. Environmental Control Level

Environmental factor	Unit	Under normal conditions	In case of machine problems ¹	In emergency ²
CO ₂ partial pressure	atm	max 0.004	max 0.01	max 0.0158
Temperature	°C	18.3-26.7 ³	18.3-26.7	15.6-29.4
Dew point ⁴	°C	4.4-15.6	1.7-21.1	1.7-21.1
Air velocity	m/min	4.6-12.2	3.0-30.5	3.0-61.0
O ₂ partial pressure ⁵	atm	0.193-0.227	0.164-0.234	0.157-0.234
Partial pressure	atm	0.987-1.013	0.987-1.013	0.987-1.013
Concentration of hazardous gas ⁶	ppm	TBD	TBD	TBD
Microorganism	CFU/m ³	<1,000	<1,000	<1,000
Fine particle (>0.15 μm)	piece/m ³	<3.53 million	<3.53 million	<3.53 million
(150 μm)	piece/m ³	<TBD	<TBD	<TBD

- Notes: 1. Machine problems refers to the period from the occurrence of the problem to restoration (maximum 90 days).
 2. Emergency refers to a short period spent on rescue (maximum 12 hours).
 3. Under normal conditions, temperature is in the range of ±1.1°C and can be set to within this range.
 4. The relative humidity should not exceed 70 percent normally, and 75 percent during machine problems and emergencies, but should not fall below 25 percent.
 5. The O₂ partial pressure should not fall below 0.157 atm, and the O₂ concentration should not exceed 23.8 percent.
 6. This should comply with MHB 8060.18 (J8400003).

Table 3. Distribution of Space Station's Environment Control Functions

Module component to SS Functions of ECLSS	SS proper					JEM		ESA	Remarks
	HAB	LAB	LOG	AL	NODE	PM	ELM	COL	
Pressure/O ₂ partial pressure control • N ₂ /O ₂ storage/distribution • Pressure/O ₂ partial pressure control • Vent/relief • Repressurizing	*	*	(a)	(a)	(a)	(b)	(a)	(a)	(a) Distribution only (b) Rescue, storage + distribution
Air conditioning • Temperature control • Humidity control • Air circulation	*	*	*	*	*	*	*	*	
Air recycling • Removal of CO ₂ • Reduction of CO ₂ • Production of O ₂ • Treatment removal of harmful gas • Removal of fine particles/microorganisms	*	*	*	*	*	*	(c) (c)	*	(c) Maintain during development period
Monitoring of environment • Monitoring of air composition (P, PO ₂ , pCO ₂) • Monitoring of temperature/humidity • Monitoring of concentration of harmful gas	*	*	*	*	*	*	*	*	
Water reprocessing • Treatment of drinking water • Treatment of waste water • Treatment of urine • Subsistence water storage/supply/distribution • Drinking water storage/supply/distribution • Water temperature adjustment/water quality monitoring	*	*	*	*	(a) (a)	(a) (a)		(a) (a)	(a) Distribution only
Waste treatment • Recovery and storage of urine and waste water • Recovery/treatment/storage of feces • " " of waste	*	*	*	*					
Detection/extinguishing of fires • Fire extinguisher • Extinguisher (fixed type/portable type)	*	*	*	*	*	*	*	*	
Support of outboard activities • Air lock support • EMU/MNU service				*	*				

(NASA) HAB: dwelling module, LAB: dwelling, LOG: supply module
AL: air lock, NODE: node
(NASDA) JEM/PM: pressurized section, JEM/ELM: supply section
(ESA) COL: Columbus module

In order to achieve the basic functions mentioned above, SS/ECLSS offers pressure/O₂ partial pressure control, air conditioning, air recycling, environment monitoring, water reprocessing, waste disposal, fire detection/extinguishing and outboard activity support (food supply and crew support are included in the dwelling and man systems) as shown in Table 3, and these functions are distributed to every module. This function

distribution is based on the concept of centralized function control aimed at economizing necessary resources through the centralized control of air recycling by ventilation between modules and of water reprocessing by water supply/recovery through piping between modules. Centralized control functions are connected to the housing module (HAB) of the SS main body and experimental module (LAB) in anticipation of zonal damage to modules and seeking refuge, and provide prolix construction.

The standard functional SS/ECLSS system is shown in Figure 1. Air recycling constitutes a complete O_2 gas recycling closed loop by the removal, reduction, and manufacturing of CO_2 . Water reprocessing constitutes a water recycling loop, which recovers drinking and subsistence water from a loop treating three quality levels of water: condensed water, subsistent waste water, and urine.

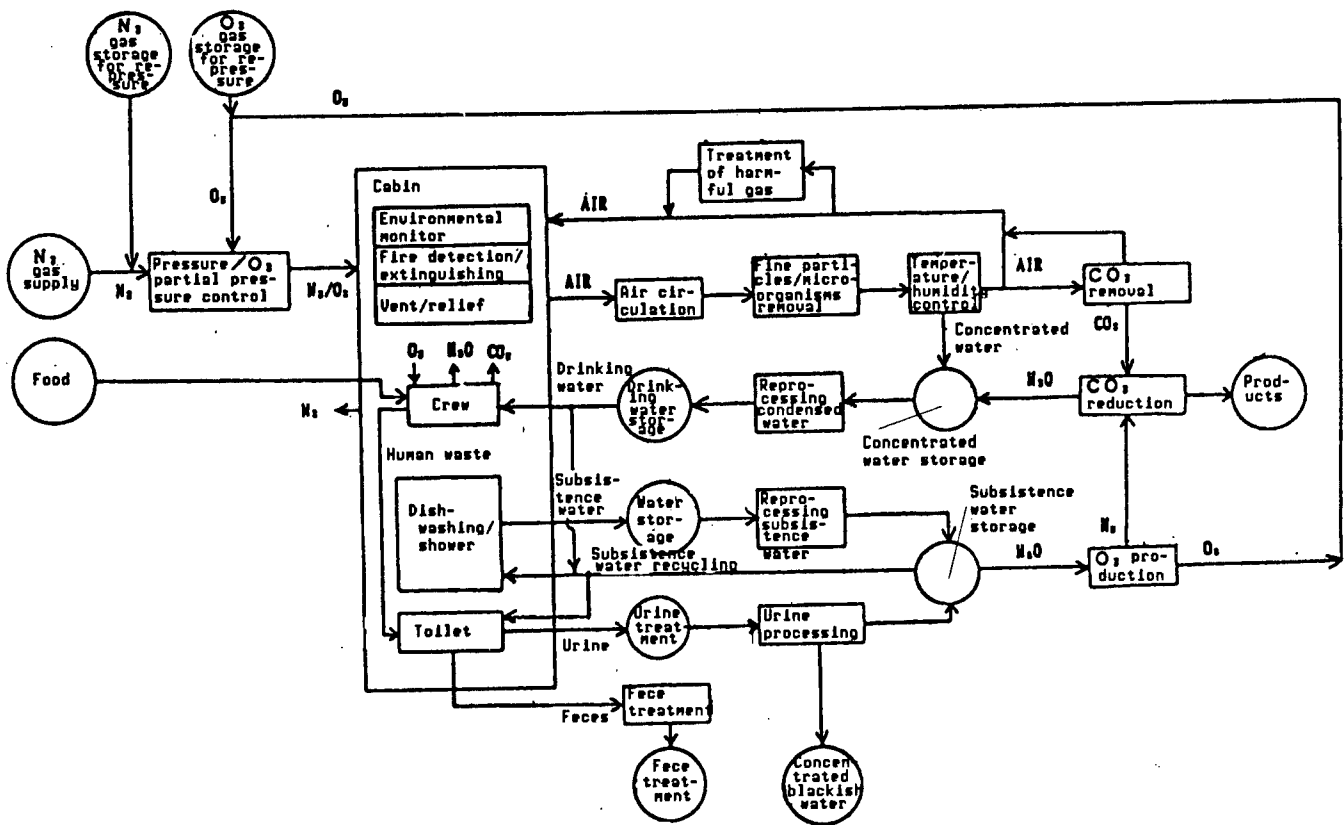

Figure 1. Standard SS ECLSS System

4. Japanese Experiment Module's Environmental Control/Life Support System (JEM/ECLSS)

The preliminary design work on JEM/ECLSS began in 1985. JEM/ECLSS can control the environment (pressure/ O_2 partial pressure control, temperature, and humidity control, air circulation, removal of CO_2 , treatment and removal of harmful gases, and removal of fine particles and

microorganisms), to ensure safety against fire, contamination and abnormal pressure (environment monitoring and fire detecting), to cope with emergencies (N_2/O_2 gas storage for emergency evacuation inside JEM, vent/relief, repressurizing, fire extinguishing and emergency life support equipment), and to support the crew's operations (hand washing, eye washing, and drinking water) in order to support two crew members in the pressurized section (PM) and supply section (ELM) of the pressurized module component to JEM (Table 3). This functional system is shown in Figure 2.

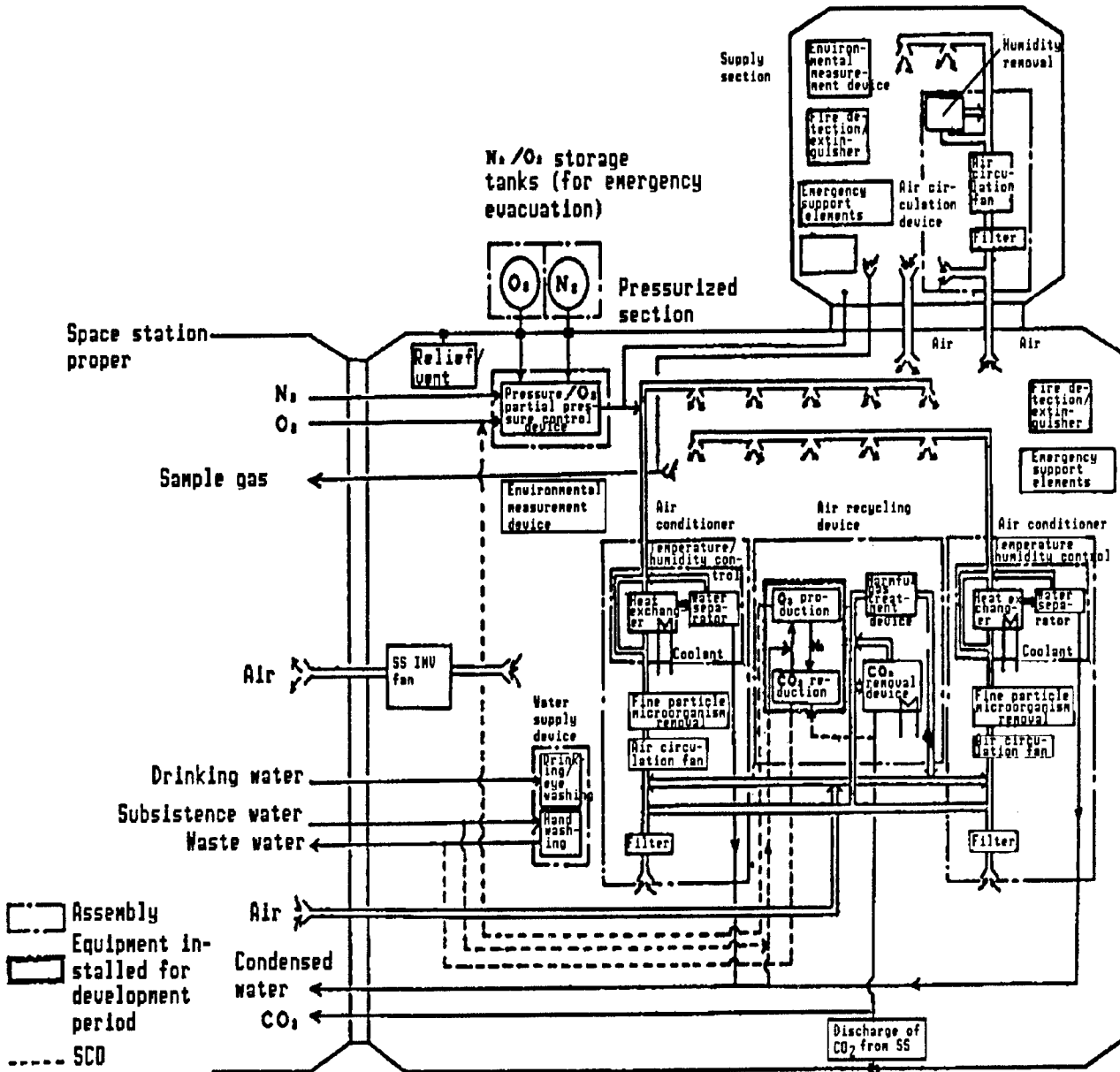

Figure 2. Standard System of JEM/ECLSS

The normal JEM/ECLSS operation depends upon the ECLSS functions of the SS proper to control pressure/O₂, remove CO₂, and treat and remove harmful gases through ventilation between the SS proper and JEM (SS/JEM IMV), based on the function-concentration concept. Therefore, these additional functions JEM/ECLSS possesses are used for closed hatch operation, JEM's own environmental control when SS/MEM IMV stops and emergency evacuation from JEM. Since JEM is a module to be mounted on the SS proper, it normally depends upon SS for the supply of resources (N₂/O₂ gas, water), water reprocessing, and air recycling (CO₂ reduction, O₂ production). ECLSS's main equipment and systems selected during the design testing are shown in Table 4.

Table 4. JEM/ECLSS Main Equipment and System

Main Equipment	System
Pressure/O ₂ partial pressure control	Overall pressure control priority system for N ₂ /O ₂ gas
Temperature and humidity control	Heat exchange system combining air cooling and humidity elimination, air velocity control system and centrifugal air/moisture separation system
CO ₂ removal	Recycling solid amine system
Treatment/removal of harmful gas	Absorption system and high and low temperature catalyzer oxidation system

5. Basic Technological Tasks Concerning JEM/ECLSS

Basic technological tasks in the development of the system technology, which were defined based on the results of the design testing of JEM/ECLSS, are shown in Table 5. We wish to develop JEM/ECLSS and, therefore, the solution of these problems should contribute to the development of Japan's future manned space system since ECLSS technology is a field in which Japan has no experience.

Table 5. Tasks for JEM/ECLSS System Technology

Area of technology	Results of preliminary design	Future tasks
<p>System technology</p> <p>o Manned flight environment control system in a state of nongravitation</p> <p>(Achievement goal)</p> <p>Establishment of technology for controlling pressure, temperature, and atmospheric composition, and removing carbonic acid gas</p>	<p>o Creation of items and conditions for environmental control</p> <p>o Methods selected to control pressure/oxygen partial pressure, temperature and humidity, to circulate air and to remove carbonic acid gas and harmful gas</p> <p>o Propriety of temperature control and air circulation system and of air circulation analysis confirmed by function model tests</p>	<p>o Evaluation from standpoint of space medicine</p> <p>o Interface with NASA and adjustment of distribution of component element functions</p> <p>o Control of harmful gas in all phases from development to operation</p> <p>o Creation of guidelines for selection and procurement of medicines</p>
<p>o System for coping with emergencies</p> <p>(Achievement goal)</p> <p>Establishment of technology to deal with emergencies, such as fire and system technology</p>	<p>o Fire detection/extinguishing system established</p> <p>o Items, scope and system for environment measurement established</p> <p>o Contamination of measurement/treatment system established</p>	<p>o Grasp of details of phenomenon, including fire</p> <p>o Establishment of system to deal with aftermath of emergency and restore</p> <p>o Adjustment of interface with NASA</p>

20110/9365

Space Water Processing, Gas Reprocessing Technology Discussed

43062568b Tokyo DAI SANKAI YUJIN UCHU HIKO GIJUTSU Symposium KOENSHU in Japanese 21-22 Jan 88 pp 18-21

[Article by Takashi Manabe and Haruo Ishida]

[Text] 1. Introduction

The space station project has entered its stride and the era has begun for man to live in space for long periods. In order for man to be able to live there, various resource supplies and waste treatment will become necessary. The dependence on ground supply/treatment of all of the above will boost expenses and make it difficult to maintain the entire system. Therefore, the recycling of such resources as gas and water will become indispensable in order to support a long-term manned mission. This article will, therefore, outline water processing technology and explain the points at issue.

2. Mass Balance of Space Gas/Water Recycling System

In order to create a recycling system it is necessary to keep the mass balance by ascertaining the exact amount of water used and discharged. A mass balance diagram of the space station is shown in Figure 1. The mass balance differs with the processing method adopted, and inevitably produces surplus materials/unreactive substances (water, hydrogen). In order to utilize these surplus and unreactive materials, it has been suggested to use water during life science experiments and gas as a propellant for orbit adjustments.

3. Space Water/Gas Recycling System

The water recycling system in the environment control/life support system (ECLSS) consists of the following:

- o Regenerable CO₂ removal
- o CO₂ reduction
- o Water recovery

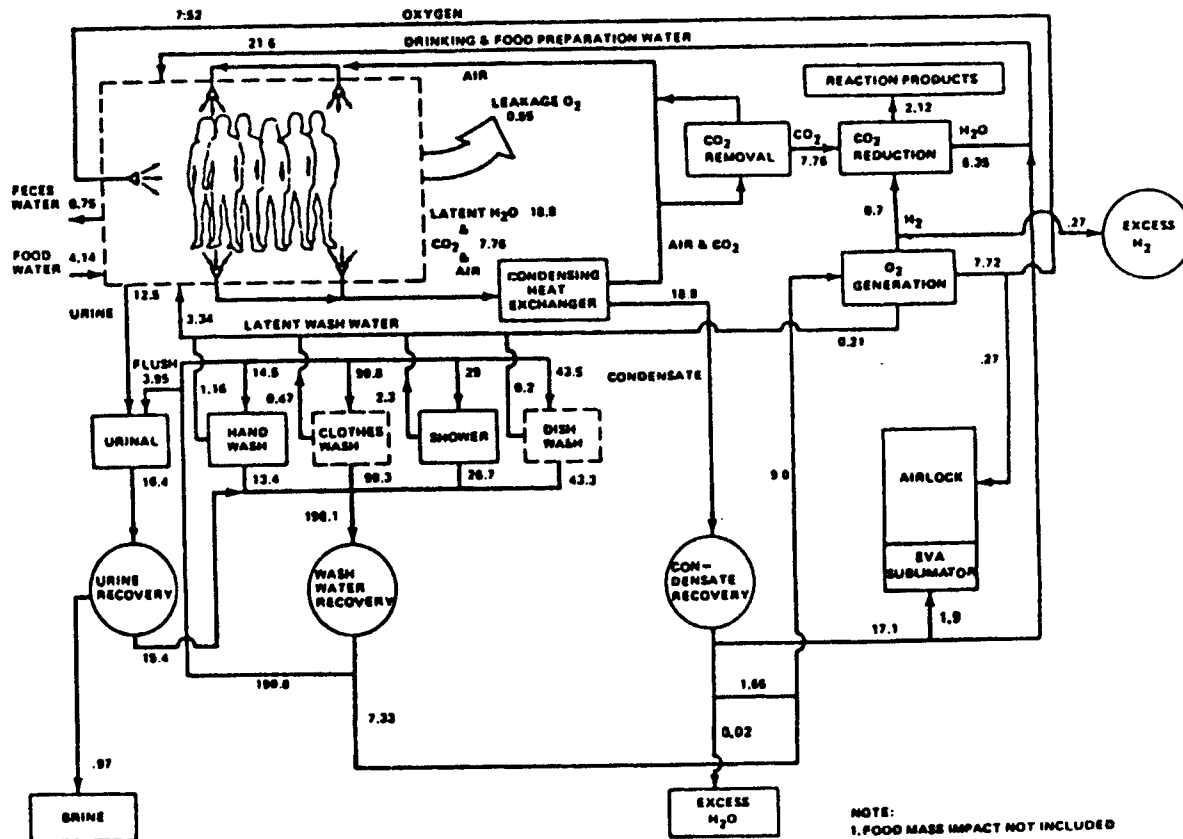

Figure 1. Example of Mass Balance in Space Station (kg/day)

3.1 Regenerable CO₂ Removal System

The regenerable CO₂ removal system is divided into a solid amine system (vacuum heating recycling or vapor recycling system), EDC (electrochemical depolarized CO₂ concentration), and molecular sieve system. NASA is thinking about adopting these three systems, while ESA and JEM are investigating the solid amine system. Each country is conducting tests using life-size BBMs. In the future it will be necessary to determine the durability of the medicine (solid amine).

3.2 CO₂ Reduction

This system generates water and carbon or methane from enriched CO₂ sent from the regenerable CO₂ removal system and from H₂ sent from the O₂ generation system through high temperature catalysis. This system includes the methods of Bosch, Sabatier and Sabatier + methane cracking, which cracks methane, a reaction product from the Sabatier method, to carbon (refer to Table 1). Basic research is being conducted on each method in order for the system to be installed during the JEM development phase. Tasks for development include: 1) the selection of catalyzers; 2) the establishment of technologies for the treatment of reaction secondary products and unreactive materials and for the separation of discharge water/gas; and 3) ensure safety from hydrogen and high temperatures.

Table 1. Outline of Carbonic Acid Gas Reduction

	Bosch Method	Sabatier method (without methane cracking)	Sabatier method (with methane cracking)
Outline of method	Reduces CO ₂ re- covered by CO ₂ removal device to C (solid carbon) through catalysis in hydrogen atmo- sphere, simultane- ously generating water. C is extracted as waste and water is sent to the elec- trolyzing process for oxygen recovery.	Reduces CO ₂ recovered by CO ₂ removal device to CH ₄ through cataly- sis in hydrogen atmo- sphere, simultaneously generating water. CH ₄ is discharged to outside the space ship, taken back to the earth or processed as resist jet fuel, and water is sent through the elec- trolyzing process for oxygen recovery.	Decomposes CH ₄ generated by Saba- tier reaction into C and H ₂ by pyroly- sis with catalyzer. C is extracted as waste and H ₂ is reutilized for CO ₂ reduction reaction.

Basic
process

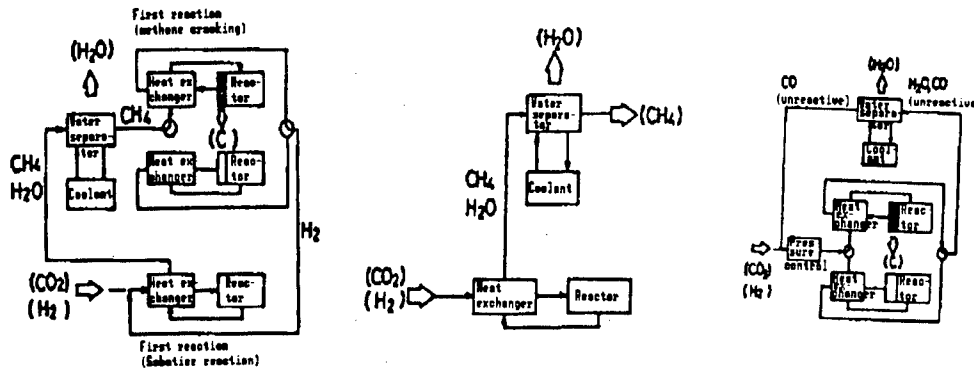

Main
reaction
formula
 $CO_2 + 2H_2 \rightarrow C$
(solid) + 2H₂O
(Bosch reaction)

$CO_2 + 4H_2 \rightarrow CH_4 + 2H_2O$
(Sabatier reaction)

1st reaction:
 $CO_2 + 4H_2 \rightarrow CH_4 + 2H_2O$
(Sabatier reaction)
2d reaction:
 $CH_4 \rightarrow C$ (solid) + 2H₂

3.3 O₂ Generation System

This system generates O₂ and H₂ from waste water by electrolysis. H₂ is fed to the CO₂ reduction system. This system consists of a solid polymer electrolyte electrolysis method (SPE method) and static feed-water electrolysis method (SF method) (see Table 2). Basic research is being conducted on each method so that this system can be installed during the JEM development phase. The SPE and SF methods are already being used for

Table 2. Outline of O₂ Generation Process

No	Item	Water vapor electrolysis: WVE	Solid polymer electrolyte-water electrolysis: SPE	Static feed-water electrolysis: SF
1.	Outline of process	Moisture in air is introduced into an electrolytic cell where only moisture is absorbed by a moisture absorptive acid electrolyte and decomposed into O ₂ and H ₂ by water electrolysis. The decomposed O ₂ is added to the outlet air and sent back to the cabin.	This process is aimed at ensuring ease in selecting materials and maintainability by using a solid polymer electrolyte in place of corrosive electrolytes. Water given pre-treatment, such as deionization, is introduced into an electrolytic cell where it is decomposed into O ₂ and H ₂ by water electrolysis. O ₂ is then extracted as nearly pure O ₂ .	Water is pretreated with asbestos and vaporized. Vapor is absorbed by a moisture-absorptive alkaline electrolyte and then decomposed into O ₂ and H ₂ by water electrolysis, so pure O ₂ can be extracted.
				
2.	Electrolyte	Moisture absorptive acid electrolyte (Example: H ₂ SO ₄ water solution)	Solid polymer electrolyte (Example: ion exchange membrane of sulfonic acid fluorine-containing polymer)	Alkaline electrolyte (Example: 35 percent KOH water solution)
3.	Reaction formula	Anode: 2H ₂ O=O ₂ + 4H ⁺ + 4e ⁻ Cathode: 4H ⁺ + 4e ⁻ = 2H ₂	Same as that of WVE	Anode: 4OH ⁻ = 2H ₂ O + O ₂ + 4e ⁻ Cathode: 4H ₂ O + de ⁻ = 2H ₂ + 4OH ⁻

Table 3. Water Processing Process (MF, HF, Phase Change Process)

Process	Combination of absorption and membrane processes	Membrane process	Phase change process	
Item	MF (Multi-filtration)	HF (Hyper-filtration)	VCD (Vapor compression distillation)	TIMES (Thermo-electric integrated membrane evaporation subsystem)

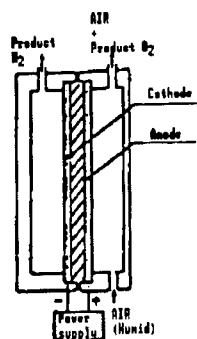
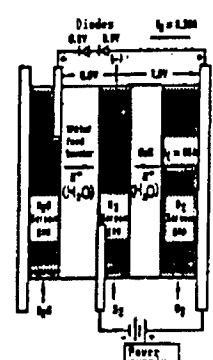
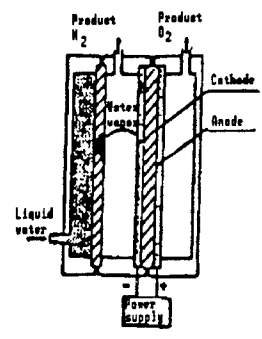
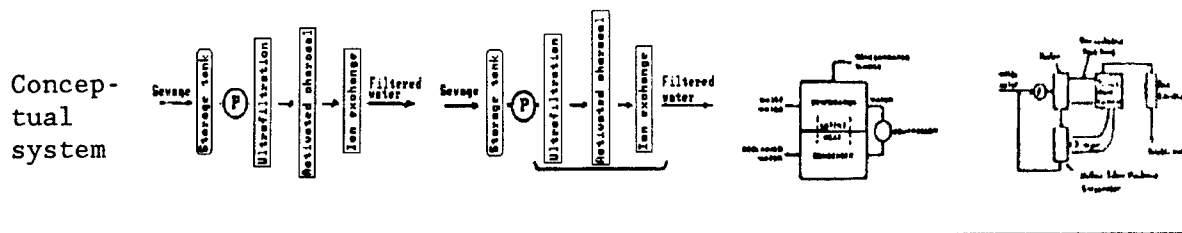

MF is a multi-stage combination of absorption and membrane processes, according to the degree of contamination, and consists of an ultrafiltration type bacterium/particle filter, absorption-type activated charcoal canister and ion exchange resin.

HF is a processing method which employs a reverse osmosis process (RO) and performs superfine filtration on the molecular level to obtain water by using a semi-permeable membrane with properties to filter water, but not ions and molecules dissolved in water, and by applying pressure stronger than the osmotic pressure of the solution. The recovery efficiency using this process differs according to purity of sewage and osmotic pressure, and can be upgraded by pretreating (absorption) process, etc.)

Sewage is heated to generate vapor and vapor is recovered for compression to a saturation temperature, and then made to dew by condenser to obtain distilled water. (Through the vapor releases its latent heat to sewage and dews then becomes distilled water, while sewage becomes vapor).

Sewage is heated and then sent to a hollow fiber membrane evaporator. The hollow fiber is decompressed and sewage evaporates from the outside of the hollow fiber. Vapor dews through the condenser connected to the cold terminal of a thermoelectric heat pump. (Latent heat during dewing is used as a source for heating sewage.)

[continued]

[Continuation of Table 3]

Main application	Processing of low contaminated water (wash water, condensed water, etc.)	High purity (removal of ions and molecules) treatment of low-contaminated water	Process of highly contaminated water like urine	Same as for VCD
------------------	--	---	---	-----------------

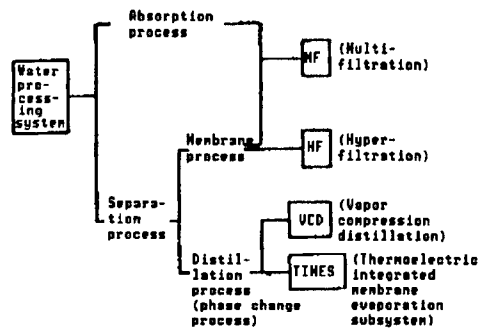

Figure 3. Water Processing System

generating high purity hydrogen for analysis and manufacturing industrial hydrogen, respectively. The guarantee of safety and reliability as a space system to which ground technology is applied and making the device more compact are cited as development tasks.

3.4 Water Processing System

This system processes: 1) condensed water from the heat exchangers for air conditioning; 2) waste water from hand washing and showers; and 3) human urine. Condensed water following processing is used as drinking water, while processed waste water and urine is used for subsistence water. For processing relatively less contaminated condensed water and waste water, a multi-filtration method using membranes (MF method) and the reverse osmosis membrane method (HF method) is employed, while for highly contaminated urine, the VCD method, a distillation method, and the TIMES method are under consideration (see Table 3 and Figure 3). Research involving these technologies is being conducted in connection with ECLSS at the National Aerospace Laboratory. There are many developmental elements involved in the distillation method since it is necessary to handle vapor under a-grav conditions without previous experience. However, in the case of the membrane method, the necessary ground technologies and experience exist, but it is necessary to create a system to upgrade the efficiency of recovery for use in space and to make the equipment more compact.

4. Conclusion

In Japan's future independent development of a manned space system it is necessary to develop a water/gas recycling system. Since Japan has the sufficient basic technology to develop such a system, it is advisable that Japan move toward full-scale development immediately.

References

1. FY 1985, 1986 Performance Report on Business Commissioned by National Space Development Agency of Japan, participation in the U.S. space station project preliminary design (Research on harmful gas processing device, etc.).
2. SAE 860943 (Status of the space station environmental control and life support system design concept).
3. The 31st space science technology association lecture meeting--Collection of lectures.

20110/9365

Man/Machine Workload Sharing in JEM Described

43062569a Tokyo DAI SANKAI YUJIN UCHU HIKO GIJUTSU Symposium KOENSHU in Japanese 21-22 Jan 88 pp 30-33

[Article by Takao Yamaguchi]

[Text] 1. Introduction

JEM (Japanese experimental module) is an aggregate in which man and machinery are interrelated and into which they are integrated, that is, a man/machine system. The allocation of the workload among machinery and men, the component elements of the system, will occur through workload sharing or "functional distribution" in terms of human engineering.

The functional distribution in JEM involving allocating various functions to men and machinery has been implemented during the early stages of design and development of JEM. In this report, the procedures for functional distribution adopted in the JEM man/machine system and examples of the functional distribution will be explained.

2. Procedures

The functional distribution in the JEM man/machine system has been carried out according to the following procedures:

(1) Definition of System's Object

The object of the JEM system has been defined as follows:

- 1) JEM consists of pressurizing, supplying, and exposure sections.
- 2) The pressurizing section conducts multipurpose experiments, such as material tests, life science tests, etc., under minimal specific gravity.
- 3) The exposure section consists of a bench and manipulator and conducts scientific observation, communications experiments, scientific and engineering experiments, and material tests mainly through remote control.

4) The supply section stores and supplies experiment samples, various kinds of gas and expendables, and hauls materials between the ground and the experimental module.

(2) Classification

JEM's general functions have been roughly classified into machine- and man-oriented functions.

1) Machine-oriented functions

- a. The functions necessary to maintain JEM's functions in some operation mode.
- b. The functions man should not be too concerned about since they involve nonproductive operations.
- c. Invariable and regular functions that can be performed through standard operational procedures.
- d. The functions related to the JEM system.

2) Man-oriented functions

- a. The functions necessary for performing missions.
- b. The functions man should be quite concerned about since they involve productive activities.
- c. Varied functions that cannot be performed through standard operational procedures.
- d. The functions related to the JEM subsystem.

(3) Core Functions

The above classification conceptually divides JEM's general functions into main classes. JEM's core functions can be described by subdividing these two categories:

- 1) Environmental control
- 2) Electric power control
- 3) Communication control
- 4) Heat control
- 5) Experiment support
- 6) Manipulator operation

Due to the limited space, mentioned cannot be made of an examination of the distribution of all these functions. This report will refer to the work station, one of the communication control functions.

The functions of the work station are subdivided as follows:

- 1) Control operation display
- 2) Video operation display
- 3) Audio-operated communications
- 4) Emergency alarm
- 5) Lighting operation

(4) Area of Core Performance

The functional performance mode has been classified into the following seven more performance areas:

- 1) Monitoring
- 2) Perception
- 3) Information processing
- 4) Interpretation of information
- 5) Decision-making
- 6) Memorization and maintenance of information

(5) Definition of Workload of Man and Machinery

The respective workloads of men and machines are defined by answering questions submitted.

(6) Properties of Man and Machinery

The properties of men and machines have been examined, with the main properties given below:

1) The properties of machinery superior to those of man

- a) Fixed and repeated work and work requiring precision
- b) Quick response to control signals
- c) Control requiring speed, precision and power
- d) Ability to process a great amount of data in a short time
- e) Calculating ability
- f) High sensitivity to impetus
- g) Very complicated control
- h) Ability to eliminate irrelevant factors or information

2) The properties of man superior to those of machinery

- a) Ability to detect specific energy (the sense of smell, taste and touch)
- b) Sensitive to various stimuli
- c) Ability to perceive patterns and generalize them
- d) Ability to detect signals under a high S/N ratio
- e) Judgment faculties requiring high level thought
- f) Adaptability to varied conditions
- g) Able to learn from experience
- h) Able to handle soft objects (catch, grasp)

(7) Human Faculties and Limits

The limitations of human physiology and performance have been examined. Functions lying beyond the limits to human faculties should be performed by machines through automation.

(8) Conditions for Automation

An examination was conducted to confirm that automation could meet the following conditions:

- 1) It can implement functions man cannot perform due to restrictions involving cost, time, and safety.
- 2) It is superior in cost performance, reliability of work, and coherence.
- 3) It enhances the crew's safety and comfort.
- 4) It reduces the crew's workload.
- 5) It improves the speed of work and operability.
- 6) It increases operational efficiency.

(9) Definition of Automation

The term automation was defined through a questionnaire.

(10) Creation of Automation Level

The extent or level of automation was established by examining its technical and economical feasibility.

3. Distribution of Functions

Based on the above procedures, functions were distributed among men and machines in the work station as shown in Table 1.

This table indicates that human roles concentrate on monitoring, decision-making, operation, and control. Control and operation represent human activities mainly involved in issuing instructions to a mechanical system by key-input. Therefore, the main assignment for the JEM crew is not to play the role of workers, but of decision makers or managers, and this perhaps applies to other functions as well.

The procedures for functional distribution described in this report do not end here. They will not terminate until the effectiveness of the system of functional distribution implemented has been evaluated and verified. Therefore, these procedures and the effectiveness of functional distribution are expected to be examined in the future through use of a mock-up, etc.

Table 1. Results of Distribution of Functions in Work Station

Area of core performance		Monitoring	Perception	Information processing	Information interpretation	Decision making	Memorization and maintenance of information	Operation and control	Area of core performance		Monitoring	Perception	Information processing	Information interpretation	Decision making	Memorization and maintenance of information	Operation and control	
Function		Function							Function									
Control operation display	Function to interface crew with control device	○			○			○	Warning, alarming, emergency	Indication of abnormal position and condition and issue of warning		○					○	
	Multipurpose data processing function			○	○	○	○	○		Support for emergency action		○	○					○
	Creation of operational environment	○	○			○		○		Indication of abnormal property	○	○				○		○
	Multisession	○				○		○	Condition of emergency action switch						○		○	
	Multindow								Illuminating operation	Lighting switch								
	Multijob	○				○											○	
Video operation display	Video circuit switching function							○	○ indicates parts allotted to man									
	INU control by camera	○					○											
	VTR operation						○	○										
	Monitor TV control						○	○										
Audio operation	Audio circuit switching function	○						○	○ indicates parts allotted to man									
	Audio terminal device control	○																

20110/9365

Radiation Effects Discussed

43062569b Tokyo DAI SANKAI YUJIN UCHU HIKO GIJUTSU Symposium KOENSHU in Japanese 21-22 Jan 88 pp 42-45

[Article by Watar Takahashi and Shunji Nagaoka]

[Text] Since manned space flights started in the United States and the Soviet Union, the problem of ionized radiation effects in space and its protection has been addressed at every opportunity as a pending issue. Since Japan is also promoting a project to implement space experiments in the near future employing a Japanese crew, who will remain in a space station for a long time, the study and evaluation of the somatological effects of ionized radiation during manned space flights from various standpoints is a crucial task to be carried out in the future. However, experimental research in this field needs to acquire the correct knowledge of the radiation environment in space and conduct corresponding ground and space experiments, a subject which has not been sufficiently studied in Japan where there are few opportunities for space experiments. As for the ingredients of space radiation, recent views will be introduced in this paper, including those on heavy charged particles, which are believed to affect organisms and human bodies, filtering through a shield like that of a space station, and on the quality of radiation as well as the possibility of synergism involving biological effects and nongravitation. The paper also will refer to the experimental projects expected to be implemented in IML-1 and SL-J missions, respectively scheduled for 1991 and 1992.

Figures 1 and 2 show the energy spectra of heavily charged particles included in space radiation and the LET spectra of high energy heavy ions, termed HZE particles (high-z-energy particles). Figure 3 shows comparative dosimetry results, including the number of HZE particles observed inside the spaceship during the D-1 mission.

When a heavy ion passes through a substance, superhigh density ionization and excitation occur at the center of the path and, at a short distance, ionization and excitation occur due to secondary electrons (δ rays). While the latter is thought to be basically the same as the action of electron rays, the former is somewhat different. For instance, an OH radical becomes so dense that recombination takes place, making the action weak. Although heat and impulse waves are then said to be generated, this is not confirmed. In comparing the fatal effects of heavy ions with those of

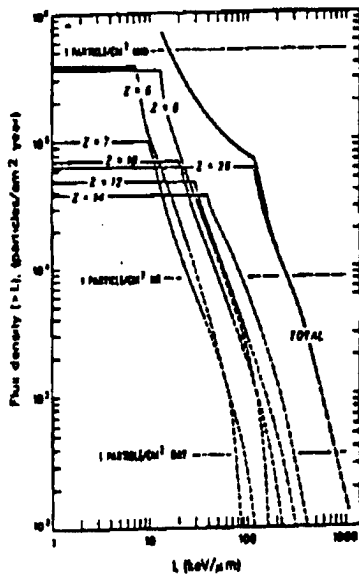

Figure 1. Energy Spectrum of Heavy Charged Particles in Cosmic Rays (Reference 1)

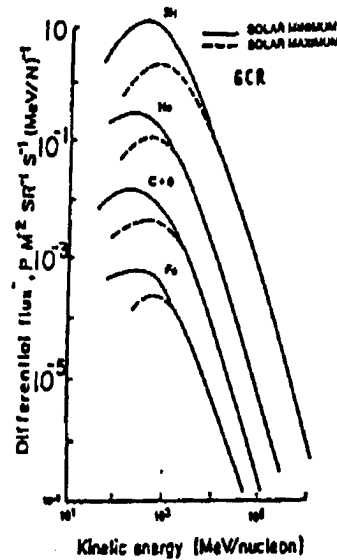

Figure 2. Integral LET Spectrum of HZE Particles (Reference 1)

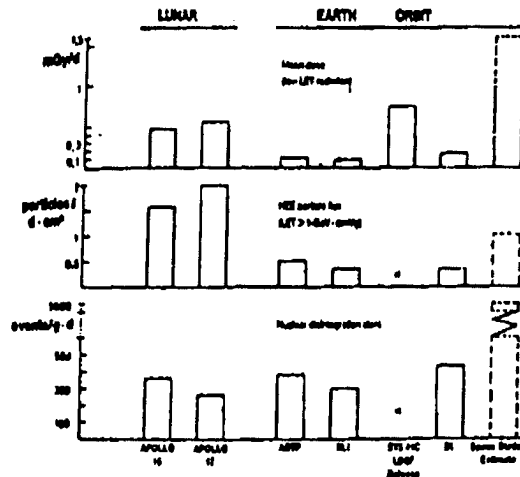

Figure 3. Comparison of Dosimetry at D-1 Mission With That of Other Biostack Experiments (Reference 2)

γ -rays and X-rays, in the case of cultured animal cells, the form of the survival curves versus the doses differs (Figure 4). However, in the case of a spore of a hay bacillus, the relationship between doses and survival rates (graduation of logarithm) in both heavy ions and γ -rays becomes a straight line. From this relationship, the RBE (rate of biological effect) can be obtained, with the relationship between the LET of ions and RBE exemplified in Figures 5 and 6. The RBE does not necessarily show maximums

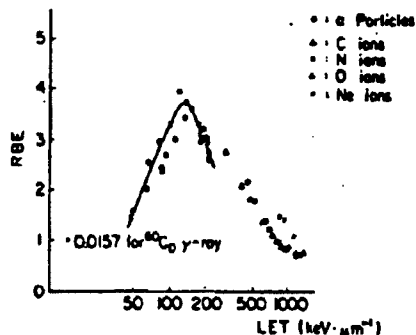

Figure 4. Survival Curve of Human Melanoma-Originated Cell (HMV-1)
 ●: X-rays
 ▲: N-ion rays (Reference 3)

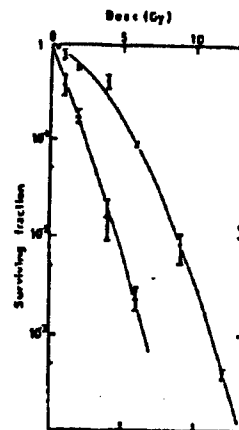

Figure 5. RBE vs. LET of Hay Bacillus Spore (Reference 4)

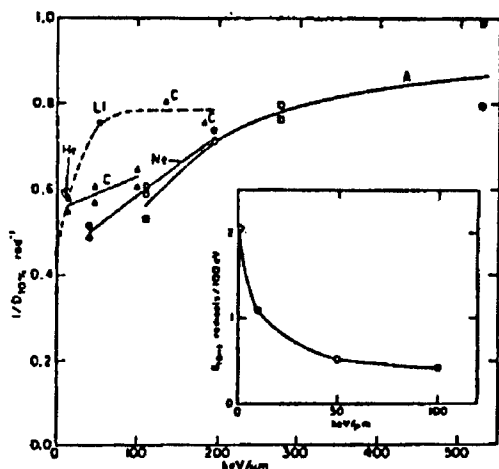

Figure 6. RBE vs. LET of V-79 Cell (Reference 5)

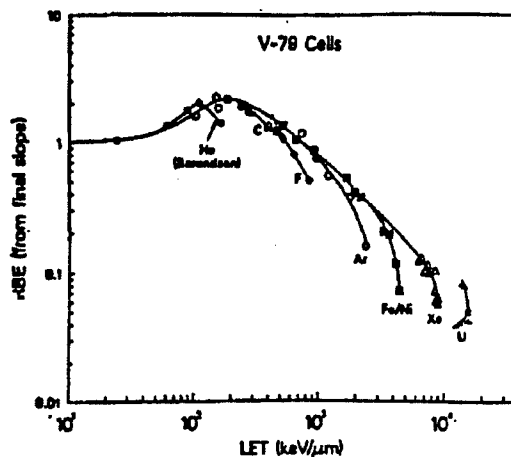

Figure 7. Radiation Sensitivity and G(OH) vs. LET (Reference 6)

by LET, as shown in the figures, and sometimes shows simple decreases or increases depending on the kind of organisms and effects observed.⁶ RBE is not always the single-valued function of LET (Figure 6).

It is said that high LET radiation, like heavy ions, has greater direct effects than low LET radiation. Figure 7 shows radiation sensitivity ($1/D_{10}$ percent- rad^{-1}) when Chinese hamster-originated cells were maximally protected by ethylene glycohols against the fatal actions of OH radicals. It also shows the tendency for direct effects to become greater as LET increases, coinciding with decreases in G(OH). However, a difference in vitality was found in 19 MeV/u Ar ions between the case in which

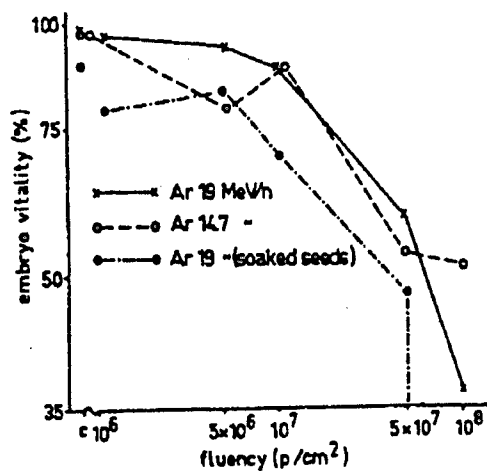

Figure 8. Embryo Vitality When Arabidopsis Seeds Were Irradiated by Ar Ions (Reference 8)

arabidopsis seeds were irradiated after having been soaked in water and that in which they were irradiated under normal conditions,⁸ and this may indicate that even Ar ions have indirect effects (Figure 8).

When LET at the center of the HZE particle is more than 200 keV/μm and the some of δ rays is more than 25 rad, more than 10 cells are said to be inflicted with an injury called a "microlesion" (Figure 9). This is said to have harmful effects on man and other mammals, such as causing the disintegration of pigment cells, damage to the rod-shaped layer of the retina and injuries to the corneas and crystal lenses.^{9,10} If corn seeds are germinated after being irradiated by γ-rays or heavy ions, white stripes develop on their leaves, with the RBE in this case reaching 12.45 in terms of the Fe ion.¹¹ There is a view that this also is due to a microlesion. Buecker, et al., examined the fatal effects of HZE particles by fixing spores of hay bacilli on a cellulose nitrate detector.

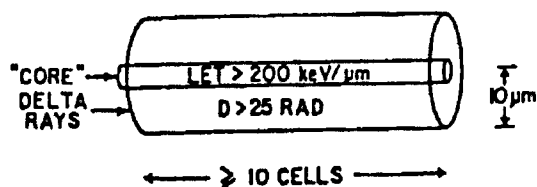

Figure 9. Conditions of HZE Particles for Generating Microlesions (Reference 9)

With respect to these constituents, Facius, et al., point out the possibility of their being due to the impulse waves of heavy ions¹² and we are conducting supplemental tests using accelerators, but have not yet reached any final conclusions. One of the reasons for this is the difficulty in providing position precision to the submicron level. Buecker and his group also examined the hatching rate of a larva and the generation of malformities by fixing the eggs of an insect, called carausius, on a solid flight path detector similar to the case of spores. Upon observation

by the eggs into those hit by HZE particles (FH), those exposed to nongravity and those hit by HZE particles in the state of artificially-applied gravity (FGH), the synergistic effects of nongravity and HZE particles have been proved.

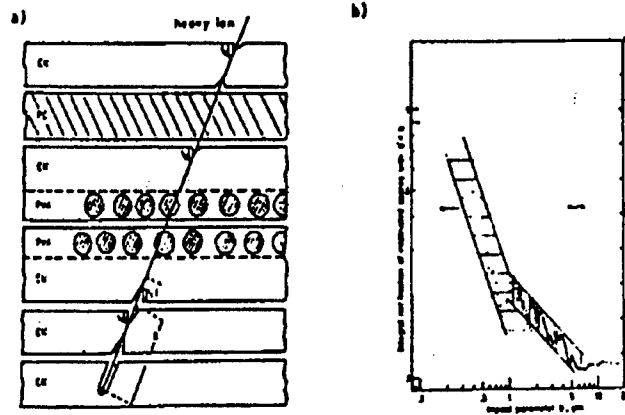

Figure 10. (a) Buecker group's experimental method to devitalize spores of hay bacilli using HZE particles
 (b) Results of above experiment (transverse axis is distance and ordinate axis is rate of inactivation) (Reference 12)

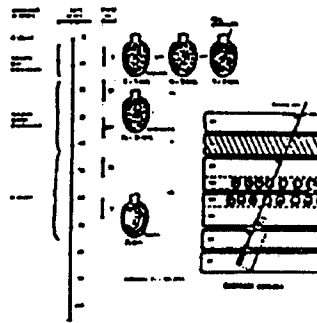

Figure 11. Experiment to Examine Effects of HZE Particles on Eggs of Carausius Morosus (Reference 13)

During the IML-1 and SL-J missions scheduled for 1991 and 1992, respectively, the National Space Development Agency of Japan, the Science and Engineering Laboratory of Waseda University, the Radiobiology Laboratory of Kyoto University, the Radiotherapeutics Laboratory, the Agrobiotic Resource Laboratory, Nomura Bioscience Laboratory, and the Institute of Physical and Chemical Research are expected to conduct biological experiments and dosimetry. Figure 13 is a conceptual sketch of the irradiation by 1.6 GeV/u Nb LBL ions, of an aluminum box containing biotic specimens, TS-16 and TLD. This experiment confirmed that the response of TDL formed an almost rectilinear relationship with the flux of

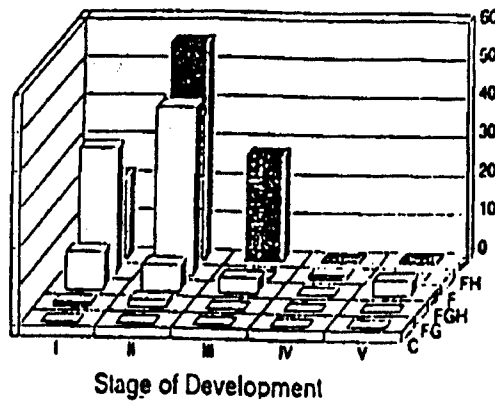

Figure 12. Inactivation of Eggs of Carausius Morosus by HZE Particles

Nb ions,¹⁴ but significant results could not be obtained from the biotic specimens, except for soybeans, probably due to the excessively strong toxicity of TS-16. The use of a YAG laser is currently being tested to remove toxicity and raise the positional precision, with experiments expected to be resumed shortly. Of the specimens shown in Figure 13, soybeans are expected to be replaced by corn during the IML-1 mission.

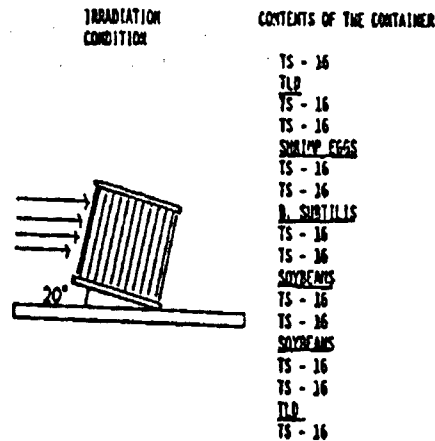

Figure 13. Arrangement of Specimens Irradiated by Nb Ions From BEVALAC of LBL (TS-16 is a CR-39 solid flight path detector)

References

1. S.B. Curtis and E.V. Benton, LBL Report 11220 (1980); J.W. Aaron, Space Station Programme JSC 30425 (1987).
2. G. Reitz, et al., ADV. SPACE RES., Vol 6 No 12, 1986, p 107.

3. K. Eguchi-Kasai, T. Kosaka, I. Kaneko, T. Takahashi, A. Marubashi, and K. Nakano, J. RADIAT. RES., Vol 28, 1987, p 213.
4. T. Takahashi, F. Yatagai, and S. Kitayama, ADV. SPACE RES., Vol 3 No 8, 1983, p 95.
5. G. Kraft, private communication.
6. For instance Sohei Kondo's "Molecular Radiobiology," Publishing Society of Tokyo University, 1972.
7. R. Roots, et al., LBL Report 11220, 1980.
8. U. Bork, et al., 26th COSPAR F6.2.4., Toulouse, 1986.
9. P. Todd, ADV. SPACE RES., Vol 3 No 8, 1983, p 187.
10. C.A. Tobias, RADIAT. RES., Vol 103, 1985, p 1.
11. M.T. Mei, et al., 8th ICRR, E52-20P, Edinburgh, 1987.
12. R. Facius, et al., LIFE SCIENCES AND SPACE RES., Vol XVI, 1978, p 151.
13. H. Buecker and G. Horneck, 3d Workshop Heavy Charged Particles in Biol. Med., GSI, 1987; H. Buecker, et al., ADV. SPACE RES., Vol 6 No 12, 1986, p 115.
14. T. Takahashi, F. Yatagai, T. Katayama, T. Doke, and H. Ohashi, Proc. Biological Sciences in Space 1986, Nagoya p 365.

20110/9365

- END -

10

This is a U.S. Government publication. Its contents in no way represent the policies, views, or attitudes of the U.S. Government. Users of this publication may cite FBIS or JPRS provided they do so in a manner clearly identifying them as the secondary source.

Foreign Broadcast Information Service (FBIS) and Joint Publications Research Service (JPRS) publications contain political, economic, military, and sociological news, commentary, and other information, as well as scientific and technical data and reports. All information has been obtained from foreign radio and television broadcasts, news agency transmissions, newspapers, books, and periodicals. Items generally are processed from the first or best available source; it should not be inferred that they have been disseminated only in the medium, in the language, or to the area indicated. Items from foreign language sources are translated. Those from English-language sources are transcribed, with the original phrasing and other characteristics retained.

Headlines, editorial reports, and material enclosed in brackets [] are supplied by FBIS/JPRS. Processing indicators such as [Text] or [Excerpts] in the first line of each item indicate how the information was processed from the original. Unfamiliar names which are rendered phonetically or transliterated by FBIS/JPRS are enclosed in parentheses. Words or names preceded by a question mark and enclosed in parentheses were not clear from the original source but have been supplied as appropriate to the context. Other unattributed parenthetical notes within the body of an item originate with the source. Times within items are as given by the source.

SUBSCRIPTION/PROCUREMENT INFORMATION

The FBIS DAILY REPORT contains current news and information and is published Monday through Friday in 8 volumes: China, East Europe, Soviet Union, East Asia, Near East & South Asia, Africa (Sub-Sahara), Latin America, and West Europe. Supplements to the DAILY REPORTs may also be available periodically and will be distributed to regular DAILY REPORT subscribers. JPRS publications generally contain less time-sensitive information and are published periodically. Current JPRS publications are listed in *Government Reports Announcements* issued semi-monthly by the National Technical Information Service (NTIS), 5285 Port Royal Road, Springfield, Virginia 22161 and the *Monthly Catalog of U.S. Government Publications* issued by the Superintendent of Documents, U.S. Government Printing Office, Washington, D.C. 20402.

U.S. Government offices may obtain subscriptions to the DAILY REPORTs or JPRS publications (hardcovers or microfiche) at no charge through their sponsoring organizations. DOD consumers are required to submit requests through appropriate

command validation channels to DIA, RTS-2C, Washington, D.C. 20301. (Telephone: (202) 373-3771, Autovon: 243-3771.) For additional information or assistance, call FBIS, (703) 527-2368, or write to P.O. Box 2604, Washington, D.C. 20013.

The public may subscribe to either hardcover or microfiche versions of the DAILY REPORTs and JPRS publications through NTIS at the above address or by calling (703) 487-4630. Subscription rates will be provided by NTIS upon request. Subscriptions are available outside the United States from NTIS or appointed foreign dealers. Back issues or single copies of the DAILY REPORTs and JPRS publications are not available. New subscribers should expect a 30-day delay in receipt of the first issue.

Both the DAILY REPORTs and the JPRS publications are on file for public reference at the Library of Congress and at many Federal Depository Libraries. Reference copies may also be seen at many public and university libraries throughout the United States.