

GAO

Report to the Honorable
Barbara Boxer, U.S. Senate

May 1998

SPACE EXPLORATION

Power Sources for Deep Space Probes



DISTRIBUTION STATEMENT A

Approved for public release;
Distribution Unlimited

19980709 086



United States
General Accounting Office
Washington, D.C. 20548

National Security and
International Affairs Division

B-279348

May 29, 1998

The Honorable Barbara Boxer
United States Senate

Dear Senator Boxer:

The National Aeronautics and Space Administration (NASA) launched its nuclear-powered Cassini spacecraft on October 15, 1997, on a 12-year mission to Saturn. You asked that we review the use of nuclear power systems for Cassini and other space missions. As agreed with your office, this report (1) describes the processes NASA used to assess the safety and environmental risks associated with the Cassini mission, (2) describes NASA's efforts to consider the use of a non-nuclear power source for the Cassini mission, (3) identifies the federal investment associated with the development of non-nuclear power sources for deep space missions, and (4) identifies NASA's planned future nuclear-powered space missions. On December 11, 1997, we briefed your staff on the results of our work. This report discusses and updates the information presented at that briefing.

Background

The Cassini Program, sponsored by NASA, the European Space Agency, and the Italian Space Agency, began in fiscal year 1990. NASA's Jet Propulsion Laboratory (JPL), which is operated under contract by the California Institute of Technology, manages the Cassini Program. The spacecraft is expected to arrive at Saturn in July 2004 and begin a 4-year period of scientific observations to obtain detailed information about the composition and behavior of Saturn and its atmosphere, magnetic field, rings, and moons. Power for the Cassini spacecraft is generated by three radioisotope thermoelectric generators (RTG) that convert heat from the natural radioactive decay of plutonium dioxide into electricity. The spacecraft also uses 117 radioisotope heater units to provide heat for spacecraft components. The spacecraft carries 72 pounds of radioactive plutonium dioxide in the RTGs and 0.7 pounds in the heater units. The Department of Energy (DOE) provided the RTGs and their plutonium dioxide fuel, and the Department of Defense (DOD) provided the Titan IV/Centaur rocket to launch the spacecraft.

According to NASA and JPL officials, most deep space missions beyond Mars, including the Cassini mission, must use RTGs to generate electrical power. The only proven non-nuclear source of electrical power for

spacecraft are photovoltaic cells,¹ also called solar arrays. However, as distance from the sun increases, the energy available from sunlight decreases exponentially. Thus, existing solar arrays cannot produce sufficient electricity beyond Mars' orbit to operate most spacecraft and their payloads.

Before launching a spacecraft carrying radioactive materials, regulations implementing federal environmental laws require the sponsoring agency, in this instance NASA, to assess and mitigate the potential risks and effects of an accidental release of radioactive materials during the mission. As part of any such assessments, participating agencies perform safety analyses in accordance with administrative procedures. To obtain the necessary presidential approval to launch space missions carrying large amounts of radioactive material, such as Cassini, NASA is also required to convene an interagency review of the nuclear safety risks posed by the mission.

RTGS have been used on 25 space missions, including Cassini, according to NASA and JPL officials.² Three of these missions failed due to problems unrelated to the RTGS. Appendix I describes those missions and the disposition of the nuclear fuel on board each spacecraft.

Results in Brief

Federal laws and regulations require analysis and evaluation of the safety risks and potential environmental impacts associated with launching nuclear materials into space. As the primary sponsor of the Cassini mission, NASA conducted the required analyses with assistance from DOE and DOD. In addition, a presidential directive required that an ad hoc interagency panel review the Cassini mission safety analyses. The directive also required that NASA obtain presidential approval to launch the spacecraft. NASA convened the required interagency review panel and obtained launch approval from the Office of Science and Technology Policy, within the Office of the President. While the evaluation and review processes can minimize the risks of launching radioactive materials into space, the risks themselves cannot be eliminated, according to NASA and JPL officials.

¹Photovoltaic cells are electronic devices that convert sunlight into electricity. In locations with sufficient sunlight, large numbers of interconnected cells are mounted on panels and used to provide electrical power for spacecraft.

²Two of the missions were launched on a single rocket.

As required by NASA regulations, JPL considered using solar arrays as an alternative power source for the Cassini mission. Engineering studies conducted by JPL concluded that solar arrays were not feasible for the Cassini mission primarily because they would have been too large and heavy and had uncertain reliability.

During the past 30 years, NASA, DOE, and DOD have invested over \$180 million in solar array technology, the primary non-nuclear power source. In fiscal year 1998, NASA and DOD will invest \$10 million to improve solar array systems, and NASA will invest \$10 million to improve nuclear-fueled systems. According to NASA and JPL officials, advances in solar array technology may expand its use for some missions; however, there are no currently practical alternatives to using nuclear-fueled power generation systems for most missions beyond the orbit of Mars.

NASA is studying eight future deep space missions between 2000 and 2015 that will likely require nuclear-fueled power systems to generate electricity for the spacecraft. None of these missions have been approved or funded, but typically about one-half of such missions are eventually funded and launched. Advances in nuclear-fueled systems and the use of smaller, more efficient spacecraft are expected to substantially reduce the amount of nuclear fuel carried on future deep space missions. Thus, NASA and JPL officials believe these future missions may pose less of a health risk than current and prior missions that have launched RTGs into space.

Safety, Environmental Impact, and Launch Approval Processes for the Cassini Mission

The processes used by NASA to assess the safety and environmental risks associated with the Cassini mission reflected the extensive analysis and evaluation requirements established in federal laws, regulations, and executive branch policies. For example, DOE designed and tested the RTGs to withstand likely accidents while preventing or minimizing the release of the RTG's plutonium dioxide fuel, and a DOE administrative order required the agency to estimate the safety risks associated with the RTGs used for the Cassini mission. Also, federal regulations implementing the National Environmental Policy Act of 1969 required NASA to assess the environmental and public health impacts of potential accidents during the Cassini mission that could cause plutonium dioxide to be released from the spacecraft's RTGs or heater units.^{3 4} In addition, a directive issued by the Executive Office of the President requires an ad hoc interagency

³42 U.S.C. 4321 et. seq., as amended.

⁴14 C.F.R. part 1216, Environmental Quality—Procedures for Implementing the National Environmental Policy Act, and 40 C.F.R. parts 1500 to 1508, Council on Environmental Quality.

Nuclear Safety Review Panel.⁵ This panel is supported by technical experts from NASA, other federal agencies, national laboratories, and academia to review the nuclear safety analyses prepared for the Cassini mission. After completion of the interagency review process, NASA requested and was given nuclear launch safety approval by the Office of Science and Technology Policy, within the Office of the President, to launch the Cassini spacecraft.

In addition to the risks associated with a launch accident, there is also a small chance that the Cassini spacecraft could release nuclear material either during an accidental reentry into Earth's atmosphere when the spacecraft passes by Earth in August 1999 or during the interplanetary journey to Saturn. Potential reentry accidents were also addressed during the Cassini safety, environmental impact, and launch review processes.

RTG Safety Assessment Process

DOE originally developed the RTGs used on the Cassini spacecraft for NASA's previous Galileo and Ulysses missions. Figure 1 shows the 22-foot, 12,400-pound Cassini spacecraft and some of its major systems, including two of the spacecraft's three RTGs.

⁵Presidential Directive/National Security Council-25, paragraph 9, as amended on May 8, 1996.

Figure 1: Cassini Spacecraft's Major Components

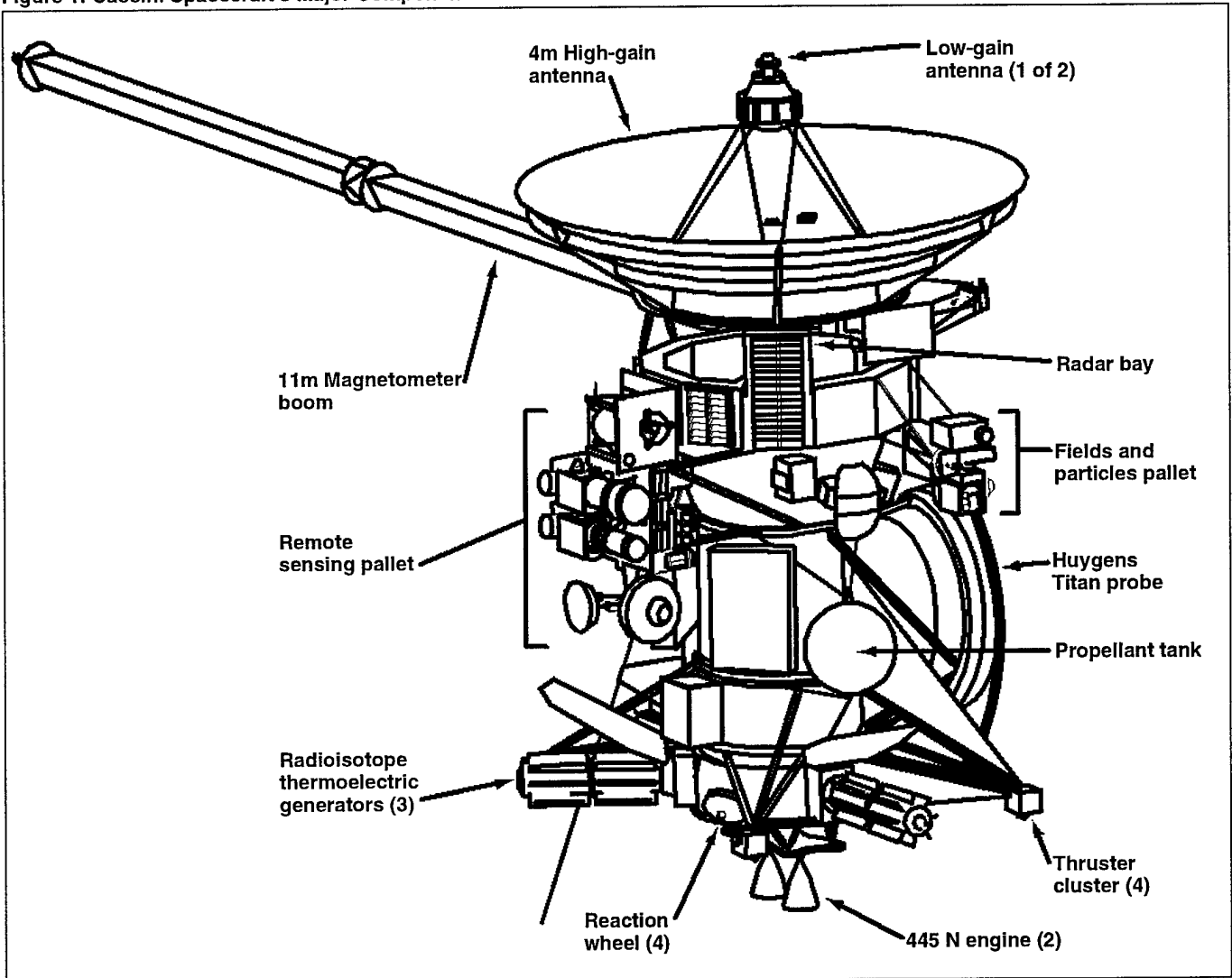

Source: NASA/JPL.

DOE designed and constructed the RTGs to prevent or minimize the release of plutonium dioxide fuel from the RTG fuel cells in the event of an accident. DOE performed physical and analytical testing of the RTG fuel

cells known as general-purpose heat source units, to determine their performance and assess the risks of accidental fuel releases. Under an interagency agreement with NASA, DOE constructed the RTGs for the Cassini spacecraft and assessed the mission risks as required by a DOE administrative order.⁶ DOE's final safety report on the Cassini mission, published in May 1997, documents the results of the test, evaluation, and risk assessment processes for the RTGs.⁷

The RTG fuel cells have protective casings composed of several layers of heat- and impact-resistant shielding and a strong, thin metal shell around the fuel pellets. According to NASA and DOE officials, the shielding will enable the fuel cells to survive likely types of launch or orbital reentry accidents and prevent or minimize the release of plutonium dioxide fuel. In addition to the shielding, the plutonium dioxide fuel itself is formed into ceramic pellets designed to resist reentry heat and breakage caused by an impact. If fuel is released from an impact-damaged fuel cell, the pellets are designed to break into large pieces to avoid inhalation of very small particles, which is the primary health risk posed by plutonium dioxide.

Cassini Environmental Impact Assessment Process

Federal regulations implementing the National Environmental Policy Act of 1969 required NASA to prepare an environmental impact statement for the Cassini mission.⁸ To meet the requirements NASA conducted quantitative analyses of the types of accidents that could cause a release of plutonium dioxide from the RTGs and the possible health effects that could result from such releases. NASA also used DOE's RTG safety analyses and Air Force safety analyses of the Titan IV/Centaur rocket, which launched the Cassini spacecraft.

NASA published a final environmental impact statement for the Cassini mission in June 1995. In addition to the analyses of potential environmental impacts and health effects, the document included and responded to public comments on NASA's analyses. NASA also published a final supplemental environmental impact statement for the Cassini mission in June 1997. According to NASA officials, NASA published the supplemental statement to keep the public informed of changes in the potential impacts of the Cassini mission based on analyses conducted subsequent to the publication of the final environmental impact statement. The supplemental

⁶Department of Energy Order 5480.23, April 30, 1992.

⁷GPHS-RTGs in Support of the Cassini Mission: Final Safety Analysis Report, Updated Executive Summary, Department of Energy, May 1997.

⁸See footnote 4.

statement used DOE's updated RTG safety analyses to refine the estimates of risks for potential accidents and document a decline in the overall estimate of risk for the Cassini mission.⁹

The environmental impact assessment process for the Cassini mission ended formally in August 1997 when NASA issued a Record of Decision for the final supplemental environmental impact statement. However, if the circumstances of the Cassini mission change and affect the estimates of accident risks, NASA is required to reassess the risks and determine the need for any additional environmental impact documentation.

Cassini Launch Approval Process

Agencies planning to transport nuclear materials into space are required by a presidential directive to obtain approval from the Executive Office of the President before launch. To prepare for and support the approval decision, the directive requires that an *ad hoc* Interagency Nuclear Safety Review Panel review the lead agencies' nuclear safety assessments. Because the Cassini spacecraft carries a substantial amount of plutonium, NASA convened a panel to review the mission's nuclear safety analyses.

NASA formed the Cassini Interagency Nuclear Safety Review Panel shortly after the program began in October 1989. The panel consisted of four coordinators from NASA, DOE, DOD, the Environmental Protection Agency, and a technical advisor from the Nuclear Regulatory Commission. The review panel, supported by approximately 50 technical experts from these and other government agencies and outside consultants, analyzed and evaluated NASA, JPL, and DOE nuclear safety analyses of the Cassini mission and performed its own analyses. The panel reported no significant differences between the results of its analyses and those done by NASA, JPL, and DOE.

The Cassini launch approval process ended formally in October 1997 when the Office of Science and Technology Policy, within the Executive Office of the President, gave its nuclear launch safety approval for NASA to launch the Cassini spacecraft. NASA officials told us that, in deciding whether to approve the launch of the Cassini spacecraft, the Office of Science and Technology Policy reviewed the previous NASA, JPL, DOE, and review panel analyses and obtained the opinions of other experts.

⁹These analyses were part of an ongoing executive branch review process for the Cassini mission.

Estimated Probabilities of Accidents and Potential Health Effects

NASA, JPL, and DOE used physical testing and computer simulations of the RTGS under accident conditions to develop quantitative estimates of the accident probabilities and potential health risks posed by the Cassini mission. To put the Cassini risk estimates in context, NASA compares them with the risks posed by exposure to normal background radiation. In making this comparison, NASA estimates that, over a 50-year period, the average person's risk of developing cancer from exposure to normal background radiation is on the order of 100,000 times greater than from the highest risk accident for the Cassini mission.

Estimated Probabilities of Launch Accidents and Potential Health Effects

For the launch portion of the Cassini mission, NASA estimated that the probability of an accident that would release plutonium dioxide was 1 in 1,490 during the early part of the launch and 1 in 476 during the later part of the launch and Earth orbit. The estimated health effect of either type of accident is that, over the succeeding 50-year period, less than one more person would die of cancer caused by radiation exposure than if there were no accident.

Estimated Probabilities of Earth Swingby and Interplanetary Trajectory Accidents and Potential Health Effects

Although the Titan IV/Centaur rocket is the United States' most powerful launch vehicle, it does not have enough energy to propel the Cassini spacecraft on a direct route to Saturn. Therefore, the spacecraft will perform two swingby maneuvers at Venus in April 1998 and June 1999, one at Earth in August 1999, and one at Jupiter in December 2000. In performing the maneuvers, the spacecraft will use the planets' gravity to increase its speed enough to reach Saturn. Figure 2 illustrates the Cassini spacecraft's planned route to Saturn.

Figure 2: Cassini Trajectory From Earth to Saturn

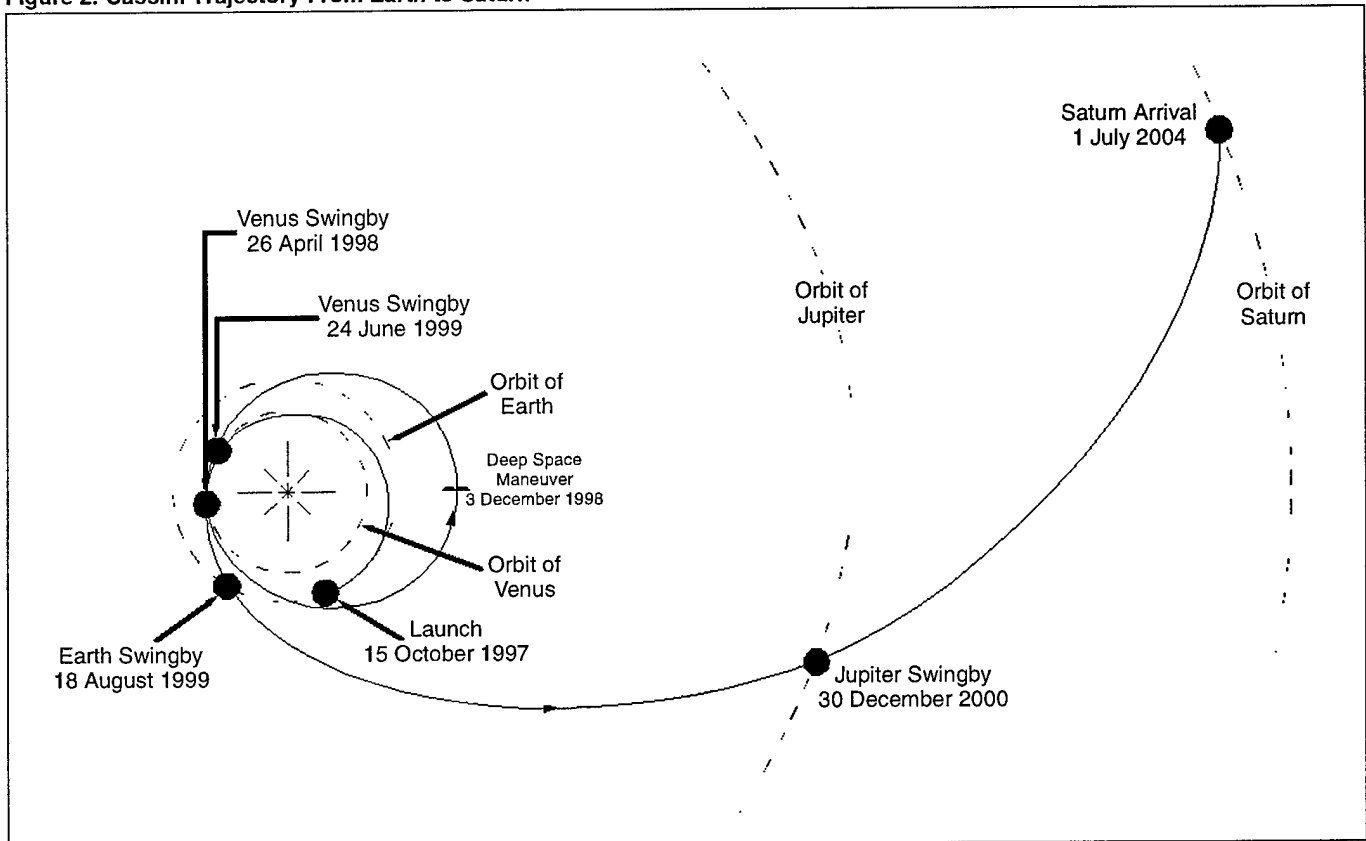

Source: NASA/JPL.

NASA estimates that there is less than a one in one million chance that the spacecraft could accidentally reenter Earth's atmosphere during the Earth swingby maneuver. To verify the estimated probability of an Earth swingby accident, NASA formed a panel of independent experts, which reported that the probability estimates were sound and reasonable.

If such an accident were to occur, the estimated health effect is that, during the succeeding 50-year period, 120 more people would die of cancer than if there were no accident. If the spacecraft were to become unable to respond to guidance commands during its interplanetary journey, the spacecraft would drift in an orbit around the sun, from which

it could reenter Earth's atmosphere in the future. However, the probability that this accident would occur and release plutonium dioxide is estimated to be one in five million. The estimated health effect of this accident is the same as for an Earth swingby accident.

Due to the spacecraft's high speed, NASA and DOE projected that an accidental reentry during the Earth swingby maneuver would generate temperatures high enough to damage the RTGs and release some plutonium dioxide. As a safety measure, JPL designed the Earth swingby trajectory so that the spacecraft will miss Earth by a wide margin unless the spacecraft's course is accidentally altered. About 50 days before the swingby, Cassini mission controllers will begin making incremental changes to the spacecraft's course, guiding it by Earth at a distance of 718.6 miles. According to NASA and JPL officials, the Cassini spacecraft and mission designs incorporate other precautions to minimize the possibility that an accident could cause the spacecraft to reenter during either the Earth swingby maneuver or the interplanetary portion of its journey to Saturn.

NASA's Consideration of a Non-Nuclear Power Source for Its Cassini Mission

NASA regulations require that, as part of the environmental analysis, alternative power sources be considered for missions planning to use nuclear power systems. JPL's engineering study of alternative power sources for the Cassini mission concluded that RTGs were the only practical power source for the mission.¹⁰ The study stated that, because sunlight is so weak at Saturn, solar arrays able to generate sufficient electrical power would have been too large and heavy for the Titan IV/Centaur to launch. The studies also noted that, even if the large arrays could have been launched to Saturn on the Cassini spacecraft, they would have made the spacecraft very difficult to maneuver and increased the mission's risk of failure due to the array's uncertain reliability over the length of the 12-year mission. Figure 3 compares the relative sizes of solar arrays required to power the Cassini spacecraft at various distances from the sun, including Saturn.

¹⁰Cassini Program Environmental Impact Statement Supporting Study, Alternate Mission and Power Study, Jet Propulsion Laboratory, July 1994, Vol. 2.

Figure 3: Relative Solar Array Sizes for the Cassini Spacecraft at Saturn, Jupiter, Mars, and Earth

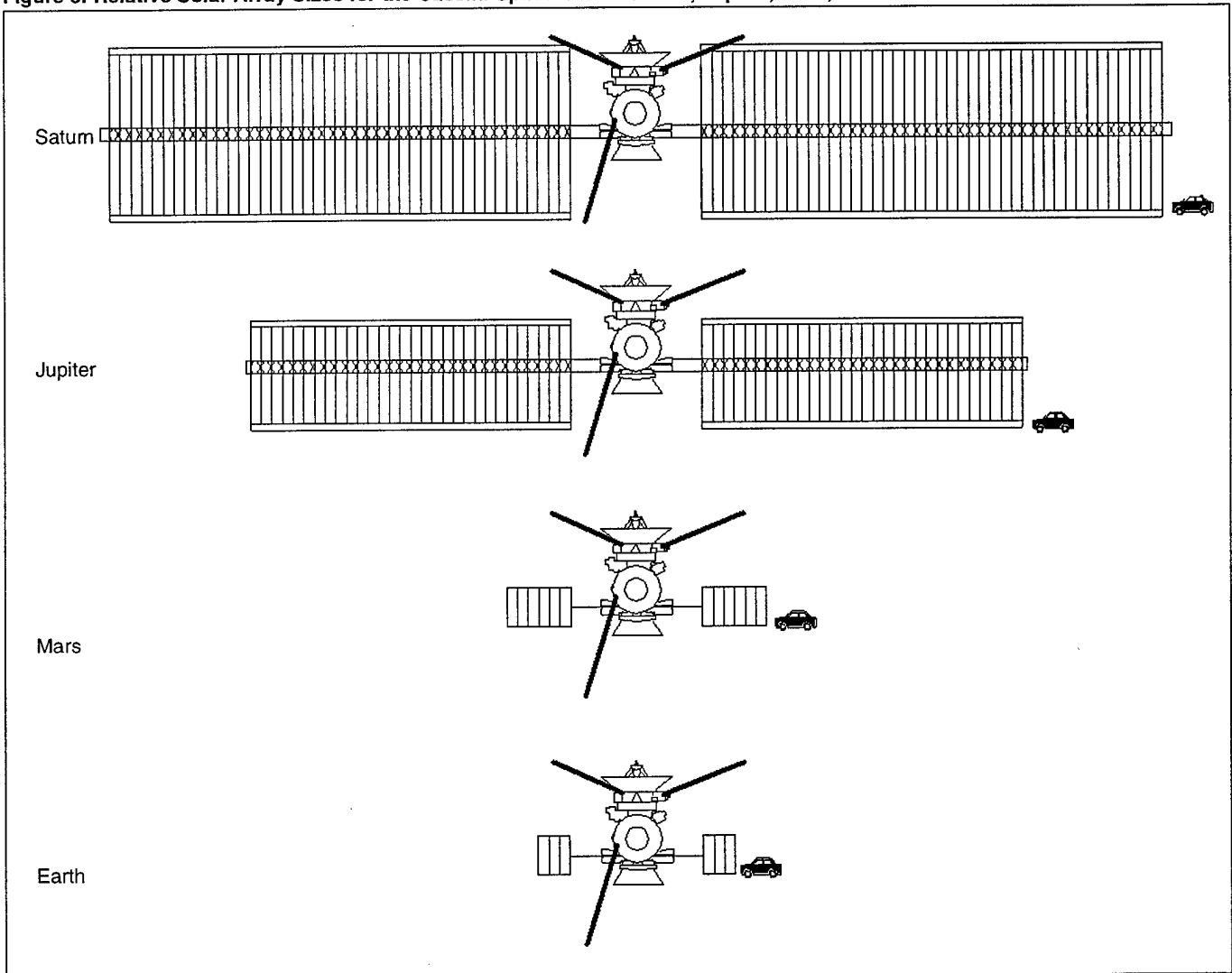

Source: NASA/JPL.

Investments in Advanced Power Generation Systems

Since 1968, NASA, DOE, and DOD have together invested more than \$180 million in solar array technology, according to a JPL estimate. The agencies are continuing to invest in improving both solar and nuclear spacecraft power generation systems. For example, in fiscal year 1998,

NASA and DOD will invest \$10 million for research and development of advanced solar array systems, and NASA will invest \$10 million for research and development of advanced nuclear-fueled systems.

NASA officials in charge of developing spacecraft solar array power systems said that the current level of funding is prudent, given the state of solar array technology, and that the current funding meets the needs of current agency research programs. The fiscal year 1998 budget of \$10 million for solar array systems exceeds the estimated 30-year average annual funding level of \$6 million (not adjusted for inflation).

According to NASA and JPL officials, solar arrays offer the most promise for future non-nuclear-powered space missions. Two improvements to solar array systems that are currently being developed could extend the range of some solar array-powered spacecraft and science operations beyond the orbit of Mars.¹¹ New types of solar cells and arrays under development will more efficiently convert sunlight into electricity. Current cells operate at 18 to 19 percent efficiency, and the most advanced cells under development are intended to achieve 22 to possibly 30 percent efficiency. Although the improvement in conversion efficiency will be relatively small, it could enable some spacecraft to use solar arrays to operate as far out as Jupiter's orbit. Another improvement to solar arrays under development will add lenses or reflective surfaces to capture and concentrate more sunlight onto the arrays, enabling them to generate more electricity. NASA's technology demonstration Deep Space-1 spacecraft, scheduled for launch in July 1998, will include this new technology.

Over the long term, limitations inherent to solar array technology will preclude its use on many deep space missions. The primary limitation is the diminishing energy in sunlight as distance from the sun increases. No future solar arrays are expected to produce enough electricity to operate a spacecraft farther than Jupiter's orbit. Another key limitation is that solar arrays cannot be used for missions requiring operations in extended periods of darkness, such as those on or under the surface of a planet or moon. Other limitations of solar arrays, including their vulnerability to damage from radiation and temperature extremes, make the cells unsuitable for missions that encounter such conditions.

¹¹Some spacecraft use solar array power systems beyond the orbit of Mars (e.g., the Near Earth Asteroid Rendezvous mission) on their way to perform science operations at targets closer to the sun. When traveling beyond Mars, solar-powered spacecraft operate in only a low-power coasting mode and perform few or no science operations, which does not demand much power.

NASA and DOE are working on new nuclear-fueled generators for use on future space missions. NASA and DOE's Advanced Radioisotope Power Source Program is intended to replace RTGs with an advanced nuclear-fueled generator that will more efficiently convert heat into electricity and require less plutonium dioxide fuel than existing RTGs. NASA and DOE plan to flight test a key component of the new generator on a space shuttle mission. The test system will use electrical power to provide heat during the test. If development of this new generator is successful, it will be used on future missions.

Future Nuclear-Powered Space Missions

NASA is currently studying eight future space missions between 2000 and 2015 that will likely use nuclear-fueled electrical generators. These missions are Europa Orbiter, Pluto Express, Solar Probe, Interstellar Probe, Europa Lander, Io Volcanic Observer, Titan Organic Explorer, and Neptune Orbiter. On the basis of historical experience, NASA and DOE officials said that about one-half of such missions typically obtain funding and are launched. In addition, several planned Mars missions would carry from 5 to 30 radioisotope heater units to keep spacecraft components warm.¹² Each heater unit would contain about 0.1 ounces of plutonium dioxide.

In accordance with NASA's current operating philosophy, spacecraft for future space science missions will be much smaller than those used on current deep space missions. Future spacecraft with more efficient electrical systems and reduced demands for electrical power, when coupled with the advanced nuclear-fueled generators, will require significantly less plutonium dioxide fuel. For example, the new nuclear-fueled generator that NASA studied for use on the Pluto Express spacecraft is projected to need less than 10 pounds of plutonium dioxide compared with 72 pounds on the Cassini spacecraft. According to NASA and DOE officials, spacecraft carrying much smaller amounts of radioactive fuel will reduce human health risks because it is anticipated that less plutonium dioxide could potentially be released in the event of an accident.

NASA and JPL officials also pointed out that planned future missions may not need to use Earth swingby trajectories. Depending on the launch vehicle used, the smaller spacecraft planned for future missions may be

¹²The Mars 2001 and 2003 missions will carry between 5 and 8 heater units each, and the Mars 2004 mission will carry approximately 30 heater units.

able to travel more direct routes to their destinations without the need to use Earth swingby maneuvers to increase their speed.

Agency Comments

In written comments on a draft of this report, NASA said that the report fairly represents NASA's environmental and nuclear safety processes for the Cassini space mission (see app. II). In addition, NASA and DOE also provided technical and clarifying comments for this report, which we incorporated as appropriate.

Scope and Methodology

To obtain information about the processes used by NASA to assess the safety and environmental risks of the Cassini mission, NASA's efforts and costs to develop non-nuclear power sources for deep space missions, and future space missions for which nuclear-fueled power sources will be used, we interviewed officials at NASA Headquarters in Washington, D.C.; JPL in Pasadena, California; and DOE's Office of Nuclear Energy, Science, and Technology in Germantown, Maryland. We reviewed the primary U.S. legislation and regulations applicable to the use of nuclear materials in space and NASA, JPL, and DOE documents pertaining to the safety and environmental assessment processes that were used for the Cassini mission. We reviewed the Cassini Safety Evaluation Report prepared by the Cassini Interagency Nuclear Safety Review Panel. We also reviewed NASA and JPL documents on the development of improved non-nuclear and nuclear electrical power sources for spacecraft and studies for future nuclear-powered space missions. We did not attempt to verify NASA and DOE estimates of risks associated with the Cassini mission or the financial and other data provided by the agencies.

We performed our work from September 1997 to February 1998 in accordance with generally accepted government auditing standards.

We are sending copies of this report to the Director of the Office of Management and Budget, the Administrator of NASA, the Secretary of Energy, and appropriate congressional committees. We will also make copies available to other interested parties on request.

Please contact me at (202) 512-4841 if you or your staff have any questions concerning this report. Major contributors to this report are Jerry Herley and Jeffery Webster.

Sincerely yours,

A handwritten signature in cursive script that reads "Allen Li".

Allen Li
Associate Director
Defense Acquisitions Issues

Contents

Letter	1
Appendix I Past Nuclear-Powered Space Missions	18
Appendix II Comments From the National Aeronautics and Space Administration	21
Figures	
Figure 1: Cassini Spacecraft's Major Components	5
Figure 2: Cassini's trajectory from Earth to Saturn	9
Figure 3: Relative Solar Array Sizes for the Cassini Spacecraft at Saturn, Jupiter, Mars, and Earth	11
Figure 11: RTG Fuel Cells During Underwater Recovery Operation	19

Abbreviations

DOD	Department of Defense
DOE	Department of Energy
JPL	Jet Propulsion Laboratory
NASA	National Aeronautics and Space Administration
RTG	radioisotope thermoelectric generators

Past Nuclear-Powered Space Missions

Since 1961 the United States has launched 25 spacecraft with radioisotope thermoelectric generators (RTG) on board. Three of the missions failed, and the spacecraft reentered Earth's atmosphere. However, none of the failures were due to problems with the RTGs.

In 1964, a TRANSIT 5BN-3 navigational satellite malfunctioned. Its single RTG, which contained 2.2 pounds of plutonium fuel, burned up during reentry into Earth's atmosphere. This RTG was intended to burn up in the atmosphere in the event of a reentry.

In 1968, a NIMBUS-B-1 weather satellite was destroyed after its launch vehicle malfunctioned. The plutonium fuel cells from the spacecraft's two RTGs were recovered intact from the bottom of the Santa Barbara Channel near the California coast. According to National Aeronautics and Space Administration (NASA) and Department of Energy (DOE) officials, no radioactive fuel was released from the fuel cells, and the fuel was recycled and used on a subsequent space mission. Figure I.1 shows the intact fuel cells during the underwater recovery operation.

Figure I.1: RTG Fuel Cells During Underwater Recovery Operation



Source: Jet Propulsion Laboratory.

Appendix I
Past Nuclear-Powered Space Missions

In 1970, the Apollo 13 Moon mission was aborted due to mechanical failures while traveling to the moon. The spacecraft and its single RTG, upon return to Earth, were jettisoned into the Pacific Ocean, in or near the Tonga Trench. According to DOE officials, no release of radioactive fuel was detected.

Comments From the National Aeronautics and Space Administration

National Aeronautics and
Space Administration
Office of the Administrator
Washington, DC 20546-0001



APR 23 1998

Mr. Allen Li
Associate Director, Defense
Acquisitions Issues
U.S. General Accounting Office
Washington, DC 20546

Dear Mr. Li:

Thank you for your letter of March 26, 1998, offering NASA the opportunity to provide comments on your draft report entitled SPACE EXPLORATION: Power Sources for Deep Space Probes (GAO/NSIAD-98-102).

We have reviewed the report and have found that it fairly represents NASA's environmental and nuclear safety processes for the Cassini mission. However, for complete accuracy, detailed comments and recommendations are enclosed.

If you have any questions or require additional information, please contact Mr. Mark Dahl at (202) 358-0306. The staffing required to support this response took approximately 20 hours.

Sincerely,

M. Dahl
Acting Deputy Administrator

Enclosure

Ordering Information

The first copy of each GAO report and testimony is free. Additional copies are \$2 each. Orders should be sent to the following address, accompanied by a check or money order made out to the Superintendent of Documents, when necessary. VISA and MasterCard credit cards are accepted, also. Orders for 100 or more copies to be mailed to a single address are discounted 25 percent.

Orders by mail:

U.S. General Accounting Office
P.O. Box 37050
Washington, DC 20013

or visit:

Room 1100
700 4th St. NW (corner of 4th and G Sts. NW)
U.S. General Accounting Office
Washington, DC

Orders may also be placed by calling (202) 512-6000
or by using fax number (202) 512 6061, or TDD (202) 512 2537.

Each day, GAO issues a list of newly available reports and testimony. To receive facsimile copies of the daily list or any list from the past 30 days, please call (202) 512-6000 using a touchtone phone. A recorded menu will provide information on how to obtain these lists.

For information on how to access GAO reports on the INTERNET, send an e-mail message with "info" in the body to:

info@www.gao.gov

or visit GAO's World Wide Web Home Page at:

<http://www.gao.gov>