

WL-TR-97-3110

THE EFFECTS OF THE COLD  
WORKING PROCESS AND  
INTERFERENCE FIT BUSHINGS ON  
THE FATIGUE LIFE OF  
POLYCARBONATE SPECIMENS  
WITH HOLES



Marc A. Huelsman  
Daniel R. Bowman

University of Dayton Research Institute  
300 College Park  
Dayton Ohio 45469-0110

April 1997

Interim Report November 1994 – April 1997

Approved for Public Release: Distribution Unlimited

FLIGHT DYNAMICS DIRECTORATE  
WRIGHT LABORATORY  
AIR FORCE MATERIEL COMMAND  
WRIGHT-PATTERSON AFB OH 45433-7542

19980714 077

**DTIC QUALITY INSPECTED 1**

## NOTICE

USING GOVERNMENT DRAWINGS, SPECIFICATIONS, OR OTHER DATA INCLUDED IN THIS DOCUMENT FOR ANY PURPOSE OTHER THAN GOVERNMENT PROCUREMENT DOES NOT IN ANY WAY OBLIGATE THE US GOVERNMENT. THE FACT THAT THE GOVERNMENT FORMULATED OR SUPPLIED THE DRAWINGS, SPECIFICATIONS, OR OTHER DATA DOES NOT LICENSE THE HOLDER OF ANY OTHER PERSON OR CORPORATION; OR CONVEY ANY RIGHTS OR PERMISSION TO MANUFACTURE, USE, OR SELL ANY PATENTED INVENTION THAT MAY RELATE TO THEM.

THIS REPORT IS RELEASABLE TO THE NATIONAL TECHNICAL INFORMATION SERVICE (NTIS). AT NTIS, IT WILL BE AVAILABLE TO THE GENERAL PUBLIC, INCLUDING FOREIGN NATIONS.

THIS TECHNICAL REPORT HAS BEEN REVIEWED AND IS APPROVED FOR PUBLICATION.

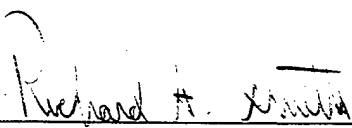
  
RICHARD A. SMITH

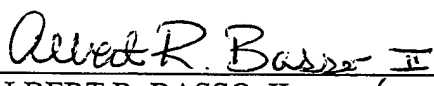
  
ALBERT R. BASSO, II

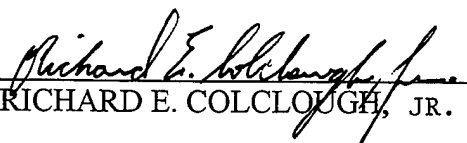
  
RICHARD E. COLCLOUGH, JR.

IF YOUR ADDRESS HAS CHANGED, IF YOU WISH TO BE REMOVED FROM OUR MAILING LIST, OR IF THE ADDRESSEE IS NO LONGER EMPLOYED BY YOUR ORGANIZATION, PLEASE NOTIFY WL/FIVE, WRIGHT-PATTERSON AFB, OH 45433-7542 TO HELP MAINTAIN A CURRENT MAILING LIST.

Do not return copies of this report unless contractual obligations or notice on a specific document requires its return

**REPORT DOCUMENTATION PAGE**

*Form Approved*  
OMB No. 0704-0188

Public reporting burden for this collection of information is estimated to average 1 hour per response, including the time for reviewing instructions, searching existing data sources, gathering and maintaining the data needed, and completing and reviewing the collection of information. Send comments regarding this burden estimate or any other aspect of this collection of information, including suggestions for reducing this burden, to Washington Headquarters Services, Directorate for Information Operations and Reports, 1215 Jefferson Davis Highway, Suite 1204, Arlington, VA 22202-4302, and to the Office of Management and Budget, Paperwork Reduction Project (0704-0188), Washington, DC 20503.

<b>1. AGENCY USE ONLY (Leave blank)</b>		<b>2. REPORT DATE</b> April 1997	<b>3. REPORT TYPE AND DATES COVERED</b> Interim Nov 94 - Apr 97	
<b>4. TITLE AND SUBTITLE</b> The Effects of the Cold Working Process and Interference Fit Bushings on the Fatigue Life of Polycarbonate Specimens with Holes			<b>5. FUNDING NUMBERS</b> C F33615-92-C-340 PE 62201F PR 2402 TA 03 WU 68	
<b>6. AUTHOR(S)</b> Marc A. Huelsman, Daniel R. Bowman				
<b>7. PERFORMING ORGANIZATION NAME(S) AND ADDRESS(ES)</b> University of Dayton Research Institute 300 College Park Dayton OH 45469-0110			<b>8. PERFORMING ORGANIZATION REPORT NUMBER</b>  UDR-TR-97-71	
<b>9. SPONSORING/MONITORING AGENCY NAME(S) AND ADDRESS(ES)</b> FlightDynamics Directorate Wright Laboratory Air Force Materiel Command Wright-Patterson AFB OH 45433-7542 POC: Richard A. Smith, AFRL/VAVE, (937) 255-6078			<b>10. SPONSORING/MONITORING AGENCY REPORT NUMBER</b>  WL-TR-97-3110	
<b>11. SUPPLEMENTARY NOTES</b>				
<b>12a. DISTRIBUTION AVAILABILITY STATEMENT</b> Approved for Public Release; Distribution Unlimited			<b>12b. DISTRIBUTION CODE</b>	
<b>13. ABSTRACT (Maximum 200 words)</b> Aircraft transparencies must provide performance and durability at an acceptable cost to be considered for production. The most important performance factor is flight safety. In order to achieve flight safety from a structural standpoint, the transparency system must withstand loads associated with flight and with bird impact. Conventional transparencies are fastened to an aircraft using bolts, and the ability to withstand flight loads or bird impact is strongly dependent upon the condition of the bolt holes in the transparency. Fatigue loading results from flight, and transparencies are subject to cracking due to the stress concentration associated with the bolts holes. Bolt hole cracks have been found by inspecting service-aged F-111, F-16, and B-1 transparencies. Transparency bolt hole cracking results in a reduced life of the transparency as well as reduced birdstrike capability. Because of the problems associated with bolt hole cracking: improvements in the fatigue life of the transparency will reduce the number of transparencies that are removed for this cause. Also, since many aircraft transparencies are now refurbished one or more times, reducing or eliminating bolt hole cracking will increase the refurbishable life of aircraft transparencies. In addition, birdstrike protection will not be reduced. This program was conducted to investigate and refine cold working techniques and to investigate interference fit bushings. Results of this program show better than two orders of magnitude improved fatigue life with interference fit bushings over the baseline.				
<b>14. SUBJECT TERMS</b> transparency durability, interference fit bushings, cold working, polycarbonate			<b>15. NUMBER OF PAGES</b> 35	
			<b>16. PRICE CODE</b>	
<b>17. SECURITY CLASSIFICATION OF REPORT</b> Unclassified	<b>18. SECURITY CLASSIFICATION OF THIS PAGE</b> Unclassified	<b>19. SECURITY CLASSIFICATION OF ABSTRACT</b> Unclassified	<b>20. LIMITATION OF ABSTRACT</b> SAR	

# CONTENTS

---

<u>Section</u>	<u>Page</u>
1 INTRODUCTION .....	1
2 BOLT HOLE PREPARATION.....	3
2.1 Cold Working Process.....	3
2.2 Interference Fit Bushing Process.....	3
3 TEST ARTICLE AND TEST PARAMETERS .....	6
3.1 Test Specimen .....	6
3.2 Cold Working Parameters .....	8
3.3 Interference Fit Bushing Parameters .....	8
3.4 Test Matrix .....	9
3.5 Test Parameters .....	9
4 TEST RESULTS AND DISCUSSION .....	12
5 CONCLUSIONS AND RECOMMENDATIONS .....	27
REFERENCES .....	29

## FIGURES

---

<u>Figure</u>		<u>Page</u>
1	Cold Working Setup .....	4
2	Interference Fit Bushing Setup .....	5
3	Test Specimen.....	7
4	Test Setup.....	11
5	Test Results for 0.150-Inch Thick Specimens with 0.386-Inch Diameter Holes .....	13
6	Test Results for 0.500-Inch Thick Specimens with 0.386-Inch Diameter Holes .....	14
7	Test Results for 0.500-Inch Thick Specimens with 0.578-Inch Diameter Holes .....	15
8	Test Results for 0.875-Inch Thick Specimens with 0.386-Inch Diameter Holes .....	16
9	Typical Modes of Failure.....	19
10	Test Results for Baseline Specimens .....	20
11	Test Results for Specimens with 10 Percent Cold Working.....	21
12	Test Results for Specimens with 12 Percent Cold Working.....	22
13	Test Results for Specimens with 14 Percent Cold Working.....	23
14	Test Results for Specimens with 3 Percent Interference Fit Bushings .....	24
15	Test Results for Specimens with 6 Percent Interference Fit Bushings .....	25
16	Test Results for Specimens with 9 Percent Interference Fit Bushings .....	26

## TABLES

---

<u>Table</u>		<u>Page</u>
1	Test Matrix.....	10

## PREFACE

The efforts reported herein were conducted by the Aerospace Mechanics Division of the University of Dayton Research Institute (UDRI), Dayton, Ohio. The program was sponsored by the Flight Dynamics Directorate, Wright Laboratory, Air Force Materiel Command, Wright-Patterson Air Force Base, Ohio, under contract F33615-92-C-3400. Technical direction was provided by Messrs. Russell E. Urzi and Richard A. Smith, WL/FIVE.

The efforts reported herein were conducted during the period of November, 1994, to April, 1997. Project supervision was provided by Mr. Blaine S. West, Head, Aerospace Mechanics Division; and Mr. Michael P. Bouchard, Leader, Structures Group. Messrs. Marc A. Huelsman and Daniel R. Bowman were the co-Principal Investigators. Coupon testing was conducted in the Advanced Materials Characterization Laboratory at UDRI under the supervision of Dr. Noel E. Ashbaugh.

## SECTION 1 - INTRODUCTION

---

Aircraft transparencies must provide performance and durability at an acceptable cost to be considered for production. The most important performance factor is flight safety. In order to achieve flight safety from a structural standpoint, the transparency system must withstand loads associated with flight and with bird impact.

Conventional transparencies are fastened to an aircraft using bolts, and the ability to withstand flight loads or bird impact is strongly dependent upon the condition of the bolt holes in the transparency. Fatigue loading results from flight, and transparencies are subject to cracking due to the stress concentration associated with the bolt holes. Bolt hole cracks have been found by inspecting service-aged F-111, F-16, and B-1 transparencies. Transparency bolt hole cracking results in a reduced life of the transparency as well as a reduced birdstrike capability. Because of the problems associated with bolt hole cracking, improvements in the fatigue life of the transparency will reduce the number of transparencies that are removed for this cause. Also, since many aircraft transparencies are now refurbished one or more times, reducing or eliminating bolt hole cracking will increase the refurbishable life of aircraft transparencies. In addition, birdstrike protection will not be reduced.

The program described in this report was conducted to continue Air Force efforts to improve aircraft transparency service life and performance. This effort complements an earlier investigation of techniques to improve the fatigue life of polycarbonate specimens with holes.<sup>1</sup> A number of potential techniques were investigated, including hole drilling techniques, hole finishing and polishing techniques, chemical treatment of the hole surface, shot peening of the hole surface, and cold working. Of these techniques cold working was found to provide the greatest improvement in fatigue life.

The program described herein was conducted to further investigate/refine cold working of holes in polycarbonate and to investigate the use of interference fit bushings, another technique which has been used frequently for fatigue life improvement of holes in metals.<sup>2, 3, 4, 5, 6</sup>

Section 2 of this document describes the cold working process and the use of interference fit bushings. Section 3 presents a description of the testing and the parameters used to conduct

the testing. Section 4 reports the results of the testing, and Section 5 reports the conclusions and recommendations for the program.

## SECTION 2 - BOLT HOLE PREPARATION

---

### 2.1 COLD WORKING PROCESS

The cold working process for holes involves forcing an oversized (larger than the hole) mandrel through the hole. The setup for the cold working process is depicted in Figure 1. The mandrel is sized to produce yielding in the material (hence, cold working) in an area around the hole. When the mandrel is removed from the hole, compressive tangential residual stresses are produced. Plastic deformation occurs within a certain radial distance (depending upon the size of the mandrel) away from the hole. Outside of this plastic zone, the deformation is elastic. When the mandrel is removed, the plastically deformed material does not return to its original position to achieve equilibrium. However, the elastically deformed material surrounding the plastically deformed material must return to its original position to achieve equilibrium. Because of the conflicting final positions for independent equilibrium, the elastically deformed material induces compressive tangential residual stresses in the plastically deformed material. The plastic deformation is the greatest around the periphery of the hole, and the maximum compressive tangential residuals result at this location. Compressive radial residual stresses remain in the material because the original position is not recovered after plastic deformation.

### 2.2 INTERFERENCE FIT BUSHING PROCESS

The use of interference fit bushings involves press-fitting a bushing into a drilled hole. In order to press the bushings into the hole, a tapered mandrel with a diameter that was roughly 0.001 to 0.002 inch larger than the bushing diameter was inserted into the end of the bushing. The slightly larger diameter prevented the leading edge of the bushing from damaging the hole surface. Load was applied to the bushing and when the bushing was pressed to the correct depth, the tapered lead mandrel could be removed from the end and used to install the next bushing. The setup for installing interference fit bushings is depicted in Figure 2. The interference fit bushings produce compressive radial stresses and tensile tangential stresses at the surface of the hole.

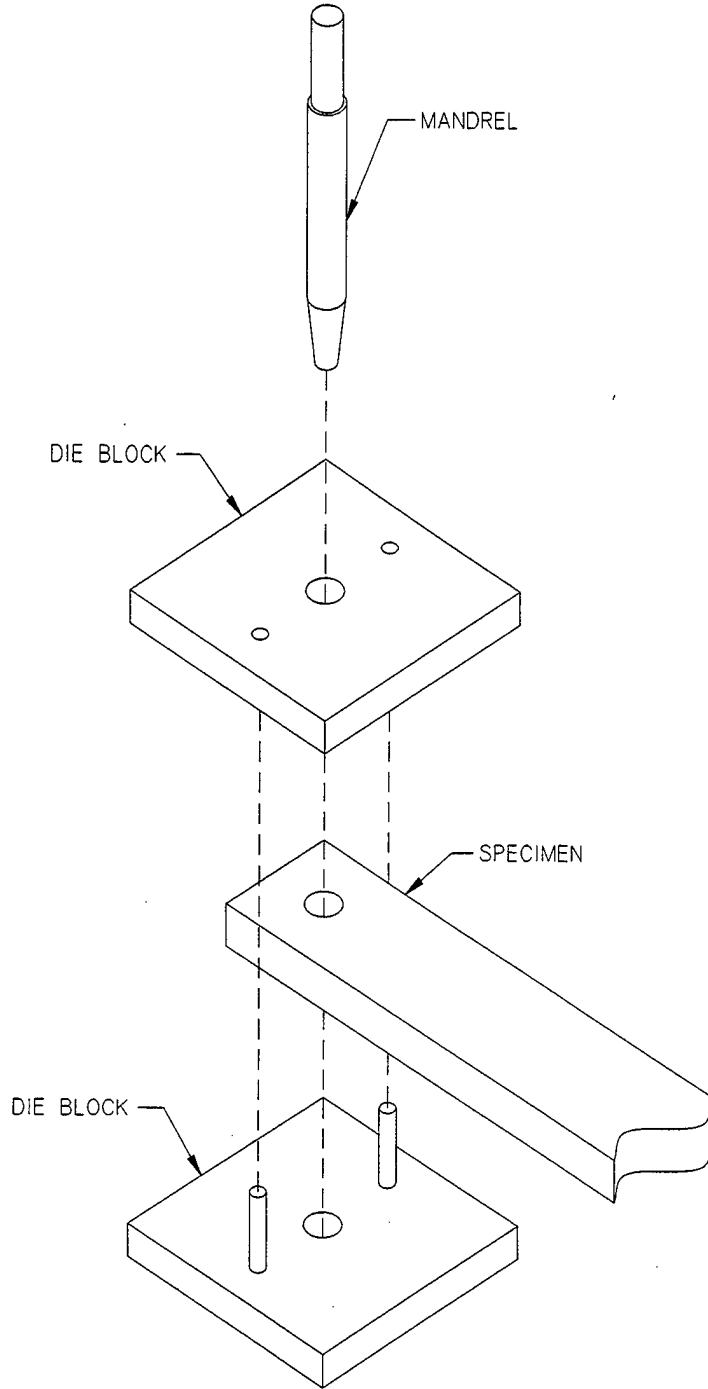

Figure 1. Cold Working Setup.

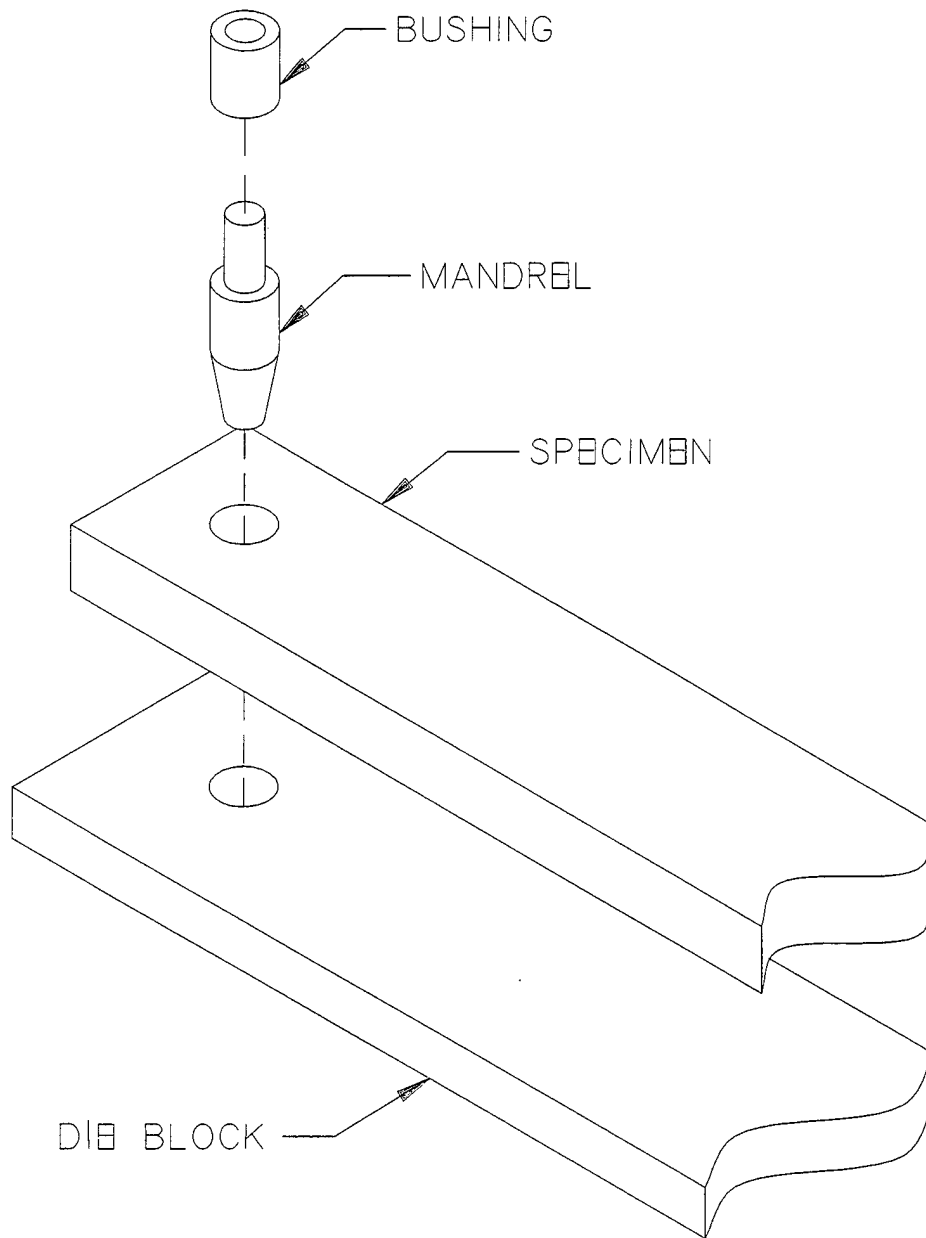

Figure 2. Interference Fit Bushing Setup.

## SECTION 3 - TEST ARTICLE AND TEST PARAMETERS

---

One main objective of the testing was to fabricate test articles that were representative of current production transparencies. Information was gathered on aircraft that have transparencies constructed with polycarbonate. Parameters, such as hole spacing, edge distance, hole size, ply thickness, etc., were used to determine the edge distance, hole spacing, and hole size for the specimens. Highest consideration was given to the B-1, F-15, F-16, and F/A-18 aircraft, while others, such as the B-2, F-4, F-111, and T-38, were considered also.

### 3.1 TEST SPECIMEN

Specimens were fabricated in the Experimental Fabrication Laboratory at the University of Dayton Research Institute. The dimensions for all specimens were 1.5 x 7.5 inches. Three thicknesses of press-polished polycarbonate sheet, 0.150-inch, 0.500-inch, and 0.875-inch thick, were purchased from the Sierracin/Sylmar Corporation. Press-polished polycarbonate was chosen since press-polishing is a necessary step in transparency fabrication, and it anneals the extruded sheet which can have residual stresses. All specimens were cut from the same sheet in the respective sizes. Two hole sizes were chosen based upon the thickness-to-diameter ratios of the various aircraft previously mentioned. The 0.150-inch and 0.875-inch thick specimens were drilled with a W (0.386-inch) standard twist drill, and the 0.500-inch thick specimens were drilled with a W standard twist drill and a 37/64 (0.578-inch) standard twist drill. Thickness-to-diameter ratios ranged from 0.39 to 2.27. The edge distance for the specimens was 0.75 inch and the hole spacing was 1.5 inches. The typical specimen is shown in Figure 3.

Specimens were fabricated on a vertical milling machine. Specimen widths were machined with a fly cutter, and the lengths were machined with the side of an end mill. Table feed rates were nominally six inches per minute. Specimen widths and the edge distances were machined within a few thousandths of an inch of the specified size. Holes were drilled with a standard twist drill, and a new bit was used for each specimen group. The drill speed was nominally 60 revolutions per minute, and the feed rate was 0.006 inch per revolution. The drilling parameters were chosen to minimize residual stresses based upon previous work by UDRI.<sup>1</sup>

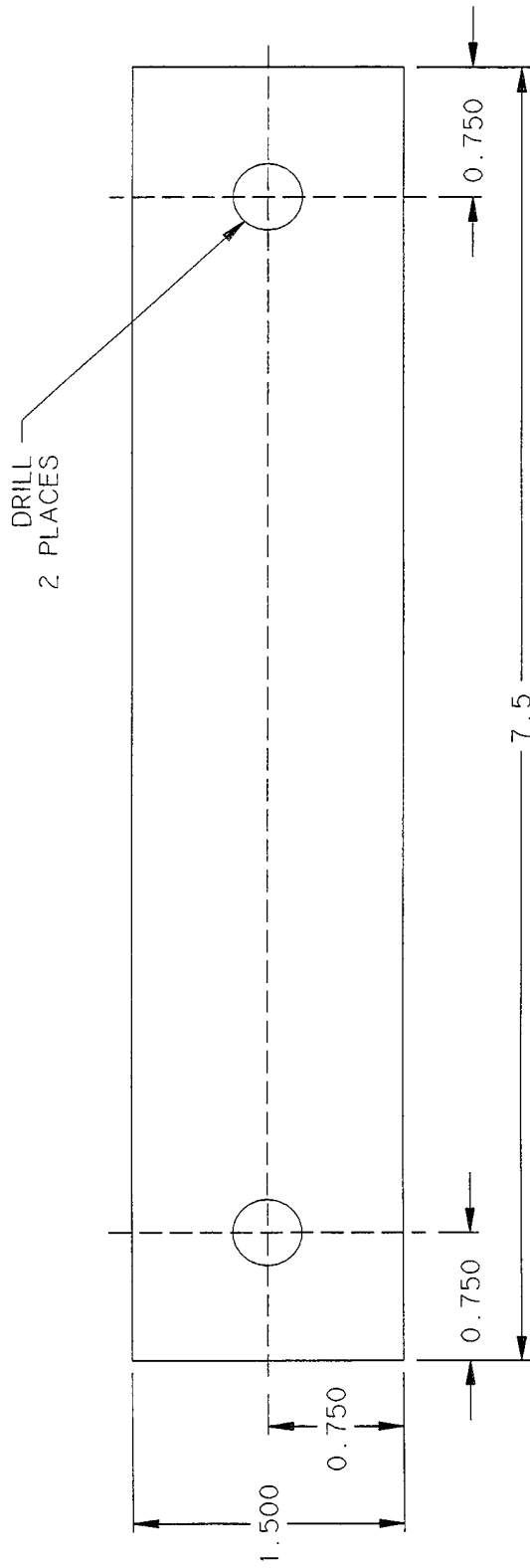

Figure 3. Test Specimen.

Clearance fit bushings for the baseline and cold worked specimens were fabricated from 6061-T6 aluminum tube and round bar stock. (Interference fit bushings are described in Section 3.3.) Tubing was used for the 0.386-inch hole sizes; 3/8-inch tubing with 0.049-inch wall thickness was cut to length without any modifications to the inside or outside diameters. Round bar stock was used for the 0.578-inch hole sizes; 9/16-inch round was cut to length and drilled with a 9/32-inch twist drill. The resulting tolerances between the bushing/hole and fastener/bushing were representative of current transparency systems. The length of the bushings was 0.050 inch larger than the thickness of the respective polycarbonate sheet. Nominally 0.025 inch of each end of the bushing protruded from the top and bottom specimen surfaces. All bushings were fabricated in the Experimental Fabrication Lab at UDRI on a lathe.

### **3.2 COLD WORKING PARAMETERS**

Three different cold working interferences were used for this program. The interferences were calculated based upon the polycarbonate hole diameter; 10, 12, and 14 percent of the hole diameter were used. Note that the actual hole diameters were not measured; the drill diameter was used for calculating mandrel diameters. As an example, the diameter for the 10 percent interference mandrel for the 0.386 diameter hole was  $0.425 (0.386 + 0.0386 = 0.425)$ .

The mandrels were fabricated from A2 tool steel and heat treated to  $R_c 60$ . The alignment blocks were constructed from 1018 cold rolled steel.

The cold working process was conducted in the Experimental Fabrication Laboratory using a manual arbor press rated for 3 1/2 tons. This method was adequate for all specimens except for the 0.875-inch thick specimens that were cold worked to 14 percent. Due to the required load (in excess of two tons), a hydraulic MTS test machine was used to force the mandrel through this group of specimens. (Less than two tons of force was obtained with the arbor press.) No lubrication was used during the cold working process.

### **3.3 INTERFERENCE FIT BUSHING PARAMETERS**

Three different interference fit bushing sizes were used for each hole size for this program. The interferences were calculated based upon the polycarbonate hole diameter; 3, 6, and 9 percent of the hole diameter were used. Note that the actual hole diameters were not measured; the drill diameter was used for calculating bushing diameters.

Interference fit bushings were fabricated from 6061-T6 aluminum round bar stock. The stock was machined, cut to length, and drilled with a 9/32-inch twist drill. The bushings were machined from 11/16-inch round bar stock for the 0.578-inch hole sizes and 9/16-inch stock for the 0.386-inch hole sizes. The resulting tolerances between the fastener and bushing were representative of current transparency systems. The length of the bushings was 0.050 inch larger than the thickness of the respective polycarbonate sheet. Nominally 0.025 inch of each end of the bushing protruded from the top and bottom surfaces specimen.

Interference fit bushings were pressed into the specimens in the Experimental Fabrication Laboratory with minimal force using a manual arbor press rated for 3 1/2 tons. No lubrication was used during this process.

### **3.4 TEST MATRIX**

The test matrix for this program is shown in Table 1. Three cold working percentages were tested as well as three interference fit bushing percentages. Only 0.500-inch thick specimens were drilled with a 0.578-inch diameter hole. A total number of 280 specimens were machined for testing.

### **3.5 TEST PARAMETERS**

Testing was conducted to determine fatigue strength versus number of cycles to failure (S-N curves) for each group of specimens. Fatigue testing was conducted using a servo-hydraulic MTS test machine. Specimens were tested at a frequency of three Hertz using a stress ratio, the ratio of the minimum stress to the maximum stress for a load cycle, of 0.1. The maximum gross section stress was varied over a range from 3650 psi to 500 psi. Testing was stopped upon reaching one million cycles if failure did not occur. The test setup is shown in Figure 4.

In order to continue testing after failure occurred at one end of the specimen, the failed end was cut off and a new hole was drilled into the specimen. The newly drilled hole was cold worked so that the failure would occur on the other end of the specimen that already had been cycled many times. An effort was made to minimize the amount of time between the failure of one end of a specimen and the test continuation after drilling and cold working the newly drilled hole.

Table 1. Test Matrix.

Thickness (in)	Specimen Type	Hole Size (in)	Interference Percentage (Percent)	Number of Specimens
0.150	Baseline	0.386	N/A	10
			10	10
	Cold Worked	0.386	12	10
			14	10
			3	10
	Interference Bushing	0.386	6	10
9			10	
0.500	Baseline	0.386	N/A	10
		0.578	N/A	10
	Cold Worked	0.386	10	10
			12	10
			14	10
		0.578	10	10
			12	10
			14	10
	Interference Bushing	0.386	3	10
			6	10
			9	10
		0.578	3	10
			6	10
			9	10
0.875	Baseline	0.386	N/A	10
	Cold Worked	0.386	10	10
			12	10
			14	10
	Interference Bushing	0.386	3	10
			6	10
			9	10
Total Number of Specimens				280

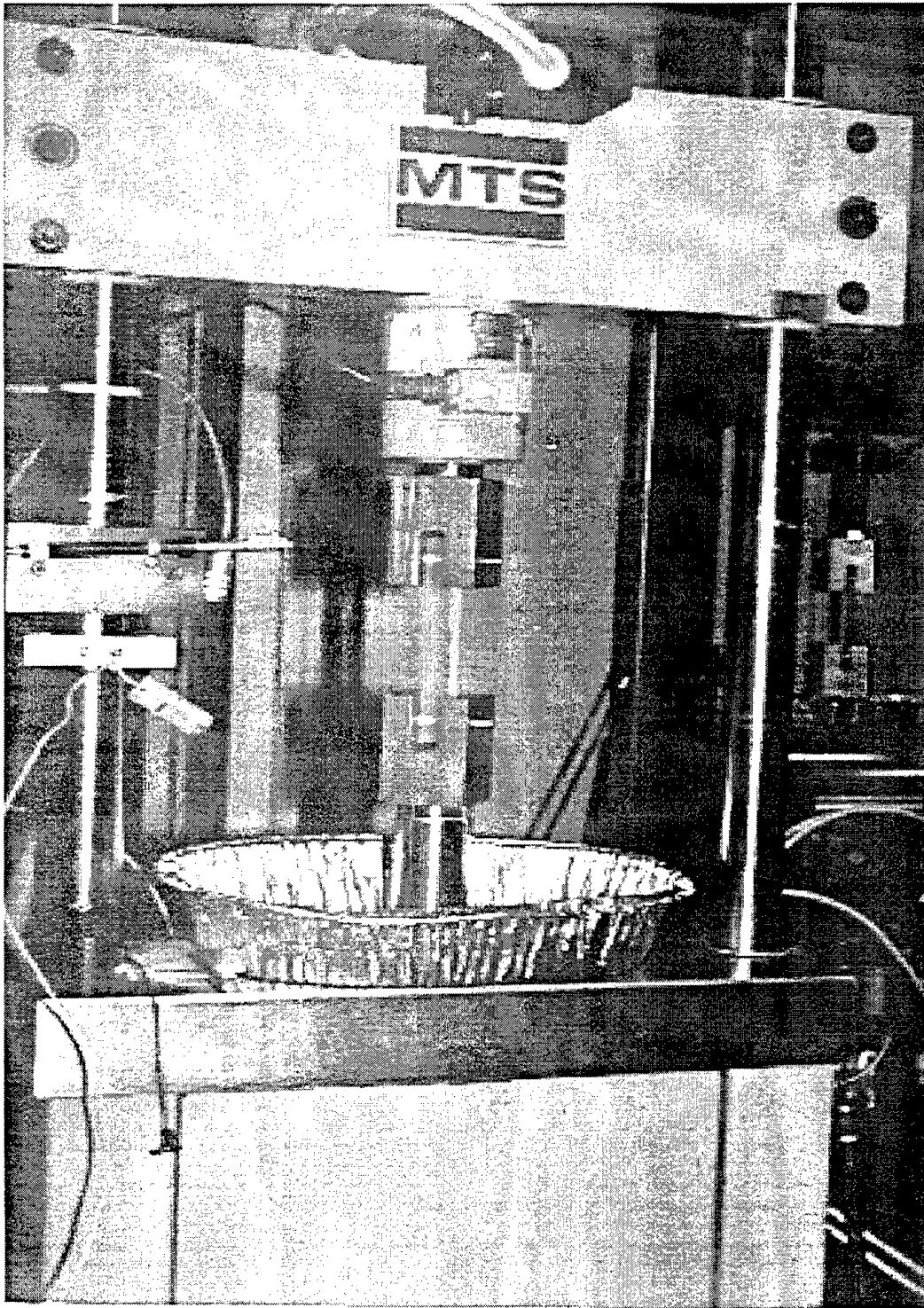

Figure 4. Test Setup.

## SECTION 4 - TEST RESULTS AND DISCUSSION

---

The test results for each specimen type are presented in Figures 5 through 8. Note that symbols at or above one million cycles do not represent failures. Testing was stopped at or near one million cycles if failure did not occur in a specimen. Any exceptions are described directly on the figure. Figure 5 presents the results for 0.150-inch thick specimens with 0.386-inch holes. Figure 6 presents the results for 0.500-inch thick specimens with 0.386-inch holes. Figure 7 presents the results for 0.500-inch thick specimens with 0.578-inch holes. Figure 8 presents the results for 0.875-inch thick specimens with 0.386-inch holes.

Only one data point is known for the specimens with interference fit bushings. After a specimen failed at one end, the failed end of the specimen was cut off so that a new hole could be drilled in the specimen. The test could be continued until failure resulted in the opposite end of the specimen. Specimens with interference fit bushings failed on the re-drilled end before failure resulted on the end of the specimen containing the interference fit bushing. Cold working the newly drilled hole also was tried with no success. For this reason only one data point was obtained for the specimens with interference fit bushings.

Results from the 0.150-inch thick/0.386-inch hole specimens (Figure 5) show an increase in the fatigue life by using cold working or interference fit bushings. Cold working resulted in an increased fatigue life compared to baseline, and interference fit bushings resulted in an increased fatigue life compared to cold working. Mixed results were found for the fatigue lives of the cold worked specimens at the three percentages for stress levels at or above 2000 psi. There was an overlap in the fatigue lives for the three levels of cold working; the different cold working percentages did not appear to have much effect on the fatigue life. At stresses below 2000 psi, however, the difference in the cold working percentages appears to have a larger effect on fatigue life; the greater the interference (over the range tested), the better the fatigue life. The best improvement for cold worked specimens was slightly less than one order of magnitude over baseline specimens. Interference fit bushing results show a considerable improvement in fatigue life from 3 percent to 6 interference. Mixed results were found for the 9 percent interference fit bushings; the 9 percent interference bushings show both an increase and a decrease compared to

6 percent interference bushings. The best improvement in fatigue life for these specimens would be achieved by using interference fit bushings having between 6 and 9 percent interference. An increase by better than two orders of magnitude over baseline was achieved using interference fit bushings.

Results from the 0.500-inch thick/0.386-inch hole specimens (Figure 6) show an increase in the fatigue life by using cold working or interference fit bushings. Cold working resulted in an increased fatigue life compared to baseline, and interference fit bushings resulted in an increased fatigue life compared to cold working. Mixed results were found for the fatigue lives of the cold worked specimens. The differences in the fatigue lives are subtle at the higher stresses, but the general trend is an increase in fatigue life with an increase in cold working percentage. An increase of less than an order of magnitude over baseline was observed. Interference fit bushing results show a considerable improvement in fatigue life from 3 percent to 6 percent interference. Mixed results were found for the 9 percent interference fit bushings, but the 9 percent interference fit bushings show at least the same fatigue life as the 6 percent bushings. The best improvement in fatigue life for these specimens would be achieved by using interference fit bushings having between six and nine percent interference. An increase of roughly two orders of magnitude was obtained over baseline specimens.

Results from the 0.500-inch thick/0.578-inch hole specimens (Figure 7) show an increase in the fatigue life by using cold working or interference fit bushings. Cold working resulted in an increased fatigue life compared to baseline, and interference fit bushings resulted in an increased fatigue life compared to cold working. Mixed results were found for the fatigue lives of the cold worked specimens. In a few instances, an increase in the cold working percentage resulted in a decrease in the fatigue life. An increase of slightly less than one order of magnitude was achieved over baseline specimens. Interference fit bushings show an increase in the fatigue life with an increase in the interference percentage. The best improvement in fatigue life for these specimens would be achieved by using interference fit bushings having between 6 and 9 percent interference (this was assumed due to the limited amount of data). An increase of more than two orders of magnitude was obtained compared to baseline specimens.

Note that there is a limited amount of data for the 0.500-inch thick/0.578-inch hole

**0.150-INCH THICK SPECIMENS, 0.386-INCH DRILL  
(t/d=0.39)**

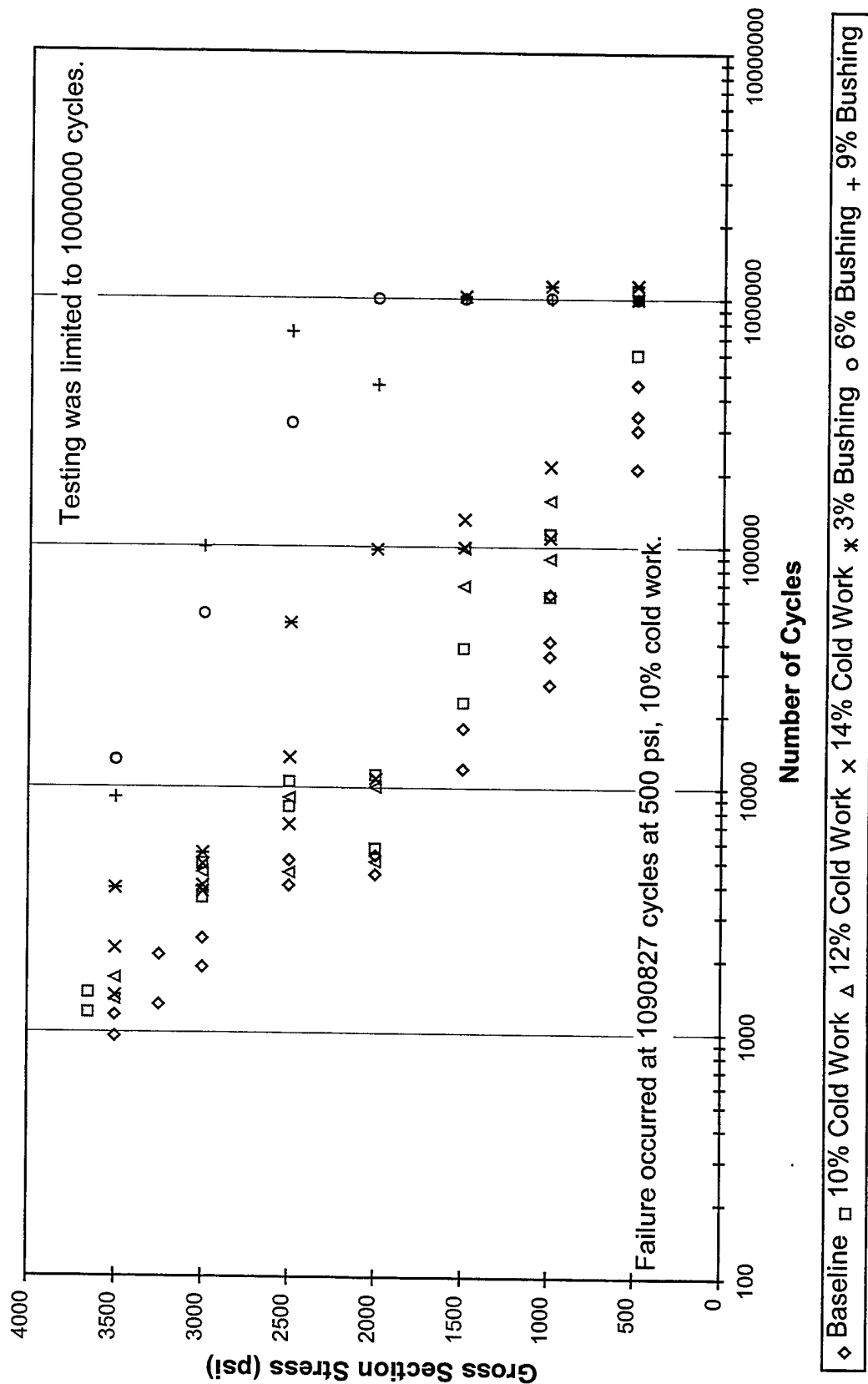
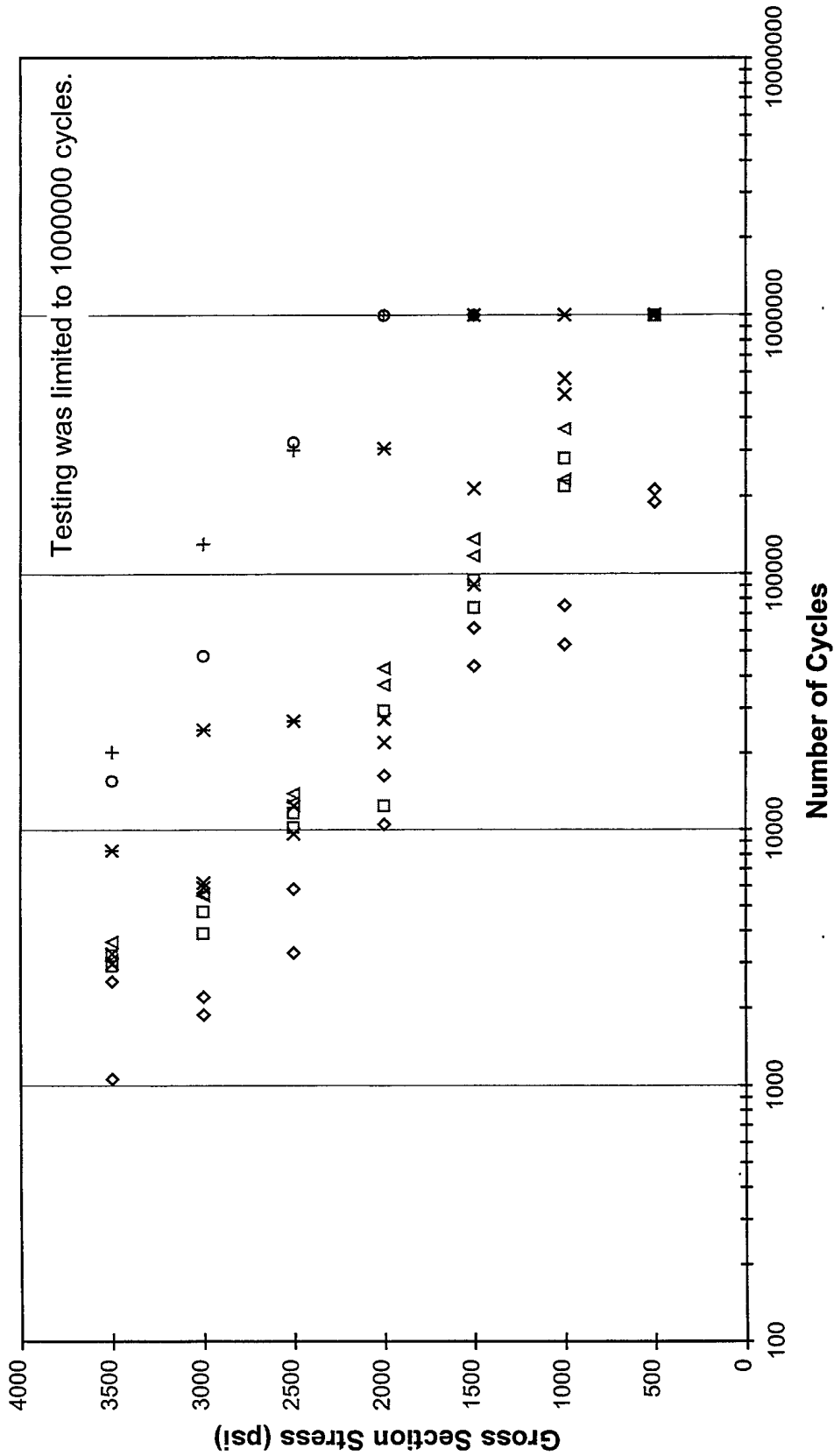

Figure 5. Test Results for 0.150-Inch Thick Specimens with 0.386-Inch Diameter Holes.

**0.500-INCH THICK SPECIMENS, 0.386-INCH DRILL  
(t/d=1.30)**



◆ Baseline □ 10% Cold Work △ 12% Cold Work × 14% Cold Work ○ 3% Bushing × 6% Bushing + 9% Bushing

Figure 6. Test Results for 0.500-Inch Thick Specimens with 0.386-Inch Diameter Holes.

**0.500-INCH THICK SPECIMENS, 0.578-INCH DRILL  
(t/d=0.87)**

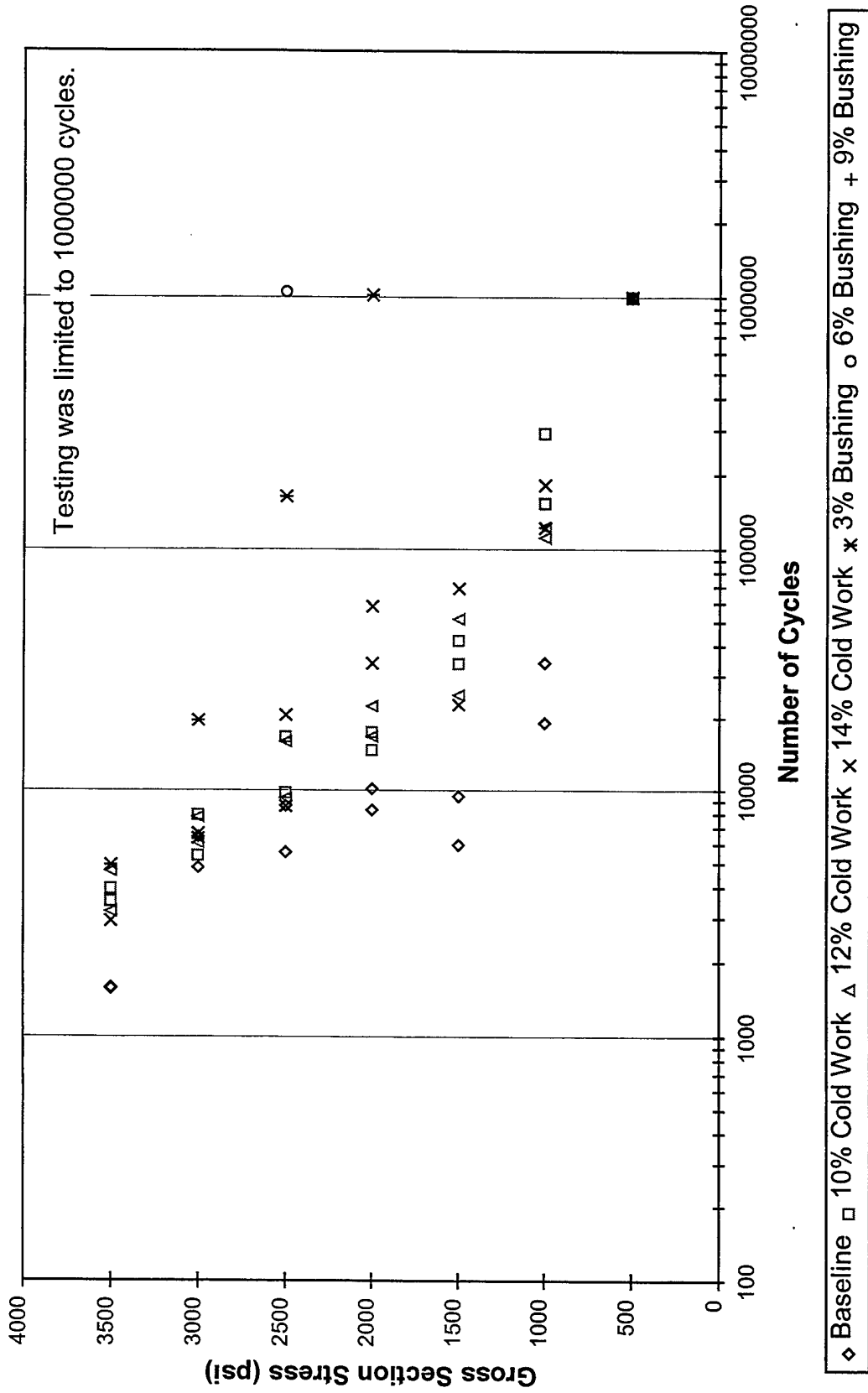
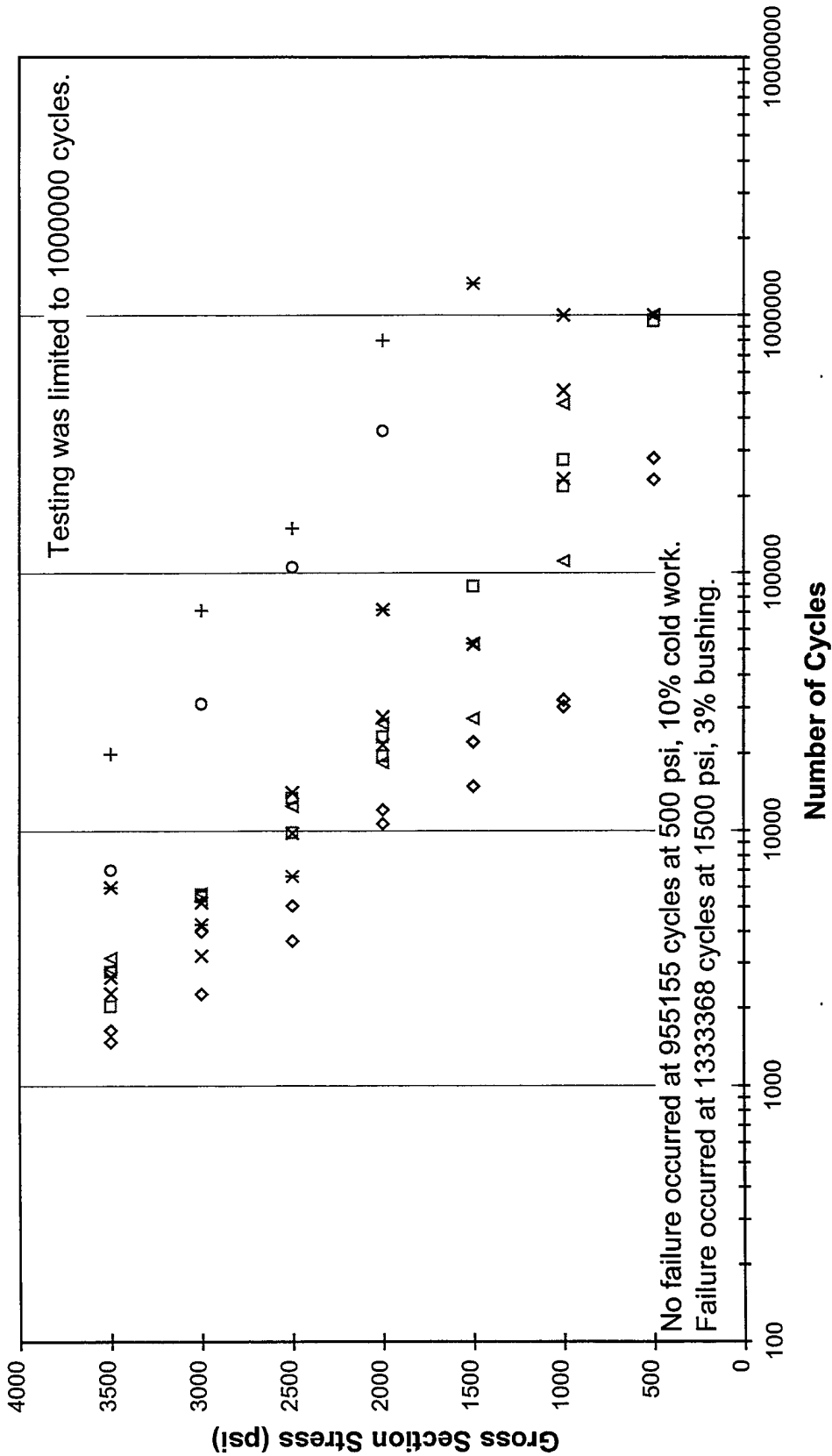

Figure 7. Test Results for 0.500-Inch Thick Specimens with 0.578-Inch Diameter Holes.

**0.875-INCH THICK SPECIMENS, 0.386-INCH DRILL  
(t/d=2.27)**



◆ Baseline □ 10% Cold Work △ 12% Cold Work × 14% Cold Work \* 3% Bushing ○ 6% Bushing + 9% Bushing

Figure 8. Test Results for 0.875-Inch Thick Specimens with 0.386-Inch Diameter Holes.

specimens with interference fit bushings. Many of the specimens failed in the gross section of the specimen away from the holes. This phenomenon occurred only in this group of specimens containing interference fit bushings.

Results from the 0.875-inch thick/0.386-inch hole specimens (Figure 8) show an increase in the fatigue life by using cold working or interference fit bushings. Cold working resulted in an increased fatigue life compared to baseline; however, not all cases showed an increase in fatigue life for the interference fit bushings compared to cold working. Mixed results again were found for the fatigue lives of the cold worked specimens. Roughly one order of magnitude increase was found compared to baseline specimens. Interference fit bushing results show an increase in fatigue for an increase in the interference percentage. The best improvement in fatigue life for these specimens was achieved by using interference fit bushings having 9 percent interference. Roughly a two order of magnitude increase in the fatigue life was found compared to baseline specimens.

Typical failures that occurred during testing are shown in Figure 9. The top specimen in the figure shows a tensile failure in the gross section away from the holes. Recall that this failure only occurred in the 0.500-inch thick specimens with 0.578-inch holes. The middle specimen shows a shear tearout failure at the right end of the specimen. The bottom specimen in the figure shows tensile failures at both ends of the specimen. Note that the extra holes in the middle and top specimens were drilled so that testing could be continued after the initial failure occurred at one end of the specimen. The bottom specimen failed first at the right end. This failed end was cut off and the specimen was drilled so that testing could be continued. The middle specimen failed first on the left end.

One final group of plots is included as Figures 10 through 16. The four thickness-to-diameter ratios ( $t/d$ ) which were tested are plotted in each figure. The figures include the data for the baseline, 10 percent cold worked, 12 percent cold worked, 14 percent cold worked, 3 percent interference fit bushing, 6 percent interference fit bushing, and 9 percent fit bushing specimens, respectively. No evident trends were obvious in the data for the various  $t/d$  ratios; the use of cold working and interference fit bushings is applicable over a wide range of  $t/d$  ratios. The

specimens with a  $t/d$  of 2.27 resulted in the least improvement with the 6 percent interference fit bushings, but mixed results were found for all other specimen types and  $t/d$  ratios.

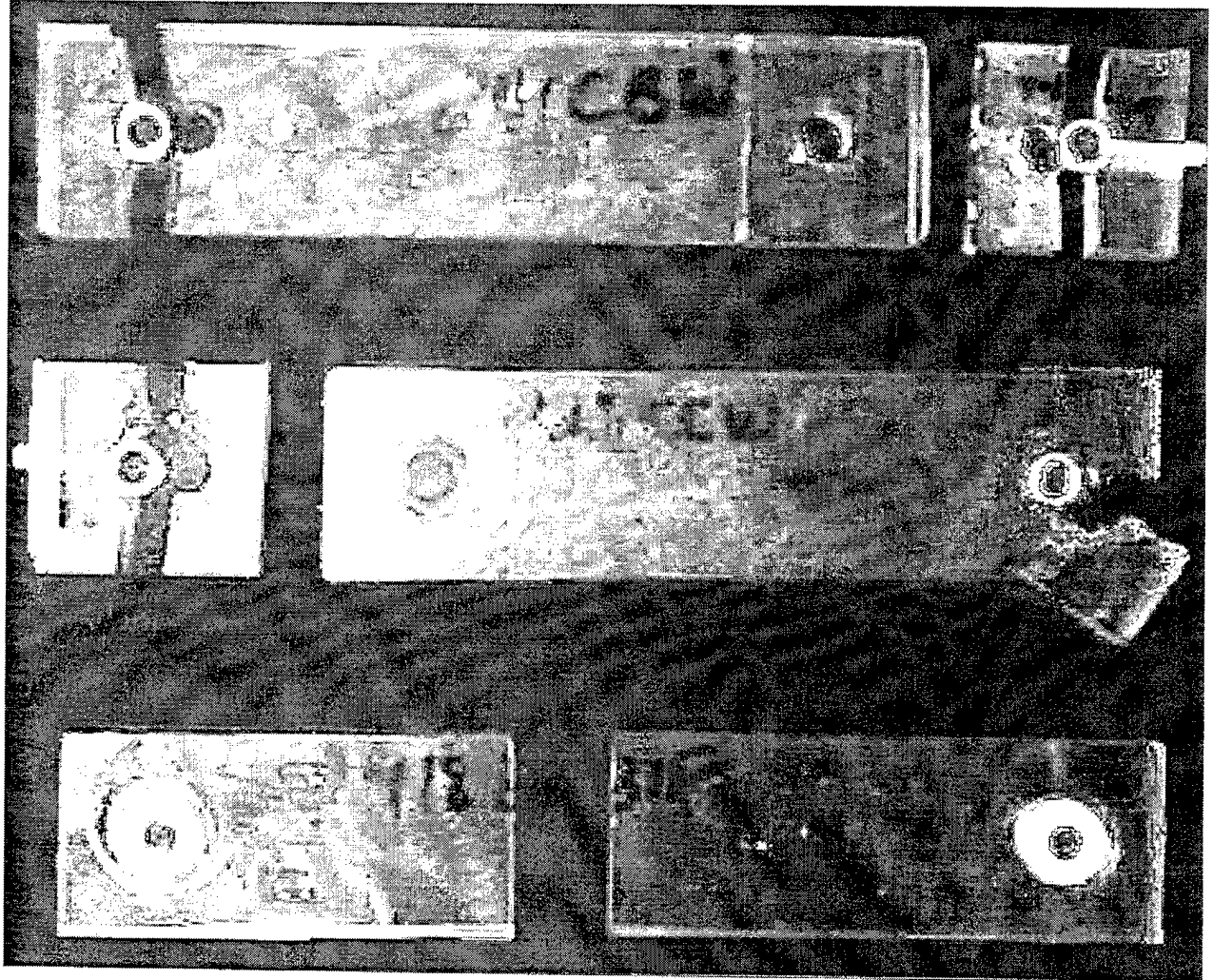

Figure 9. Typical Modes of Failure.

# BASELINE COMPARISON

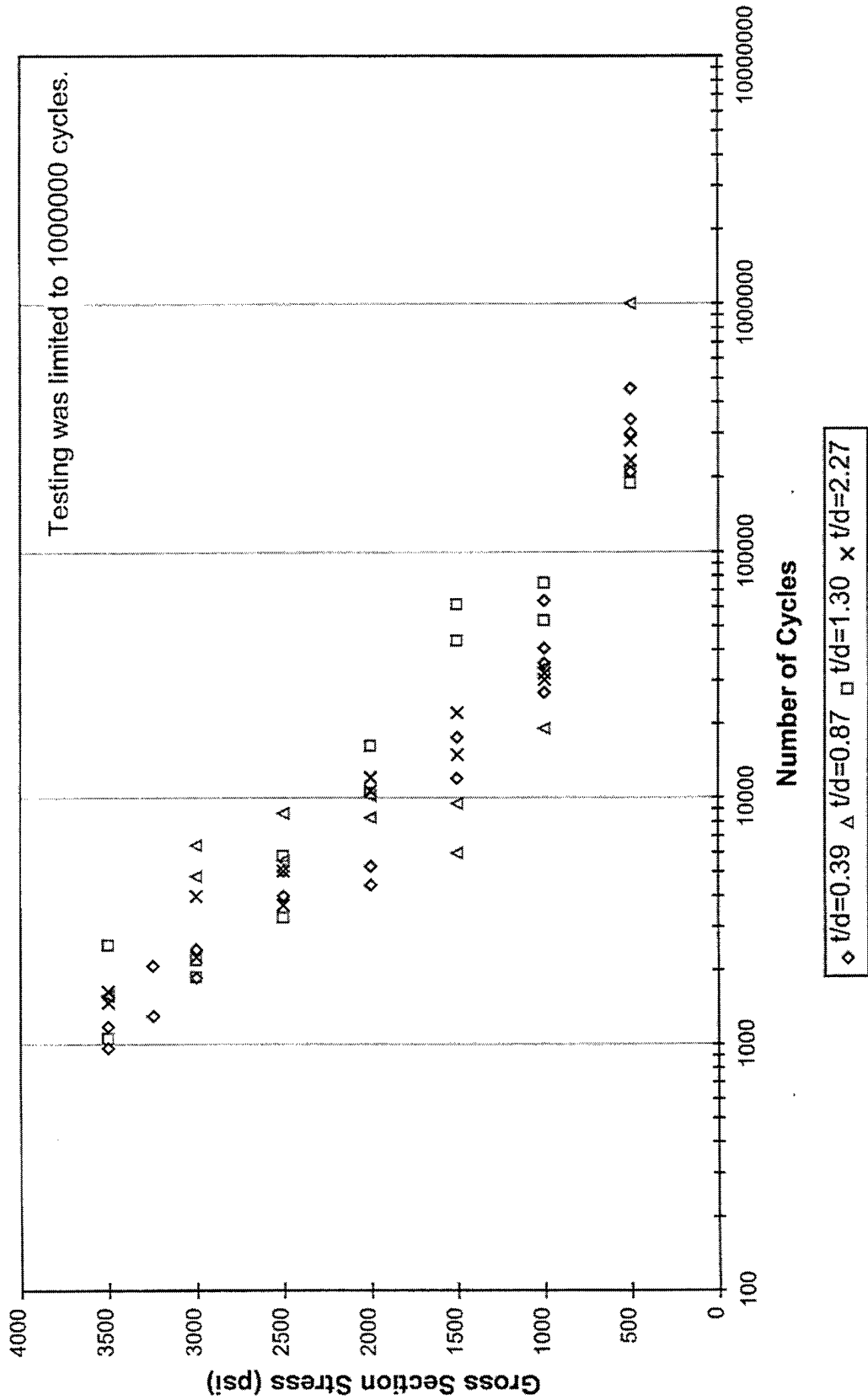

Figure 10. Test Results for Baseline Specimens.

# 10 PERCENT COLD WORK COMPARISON

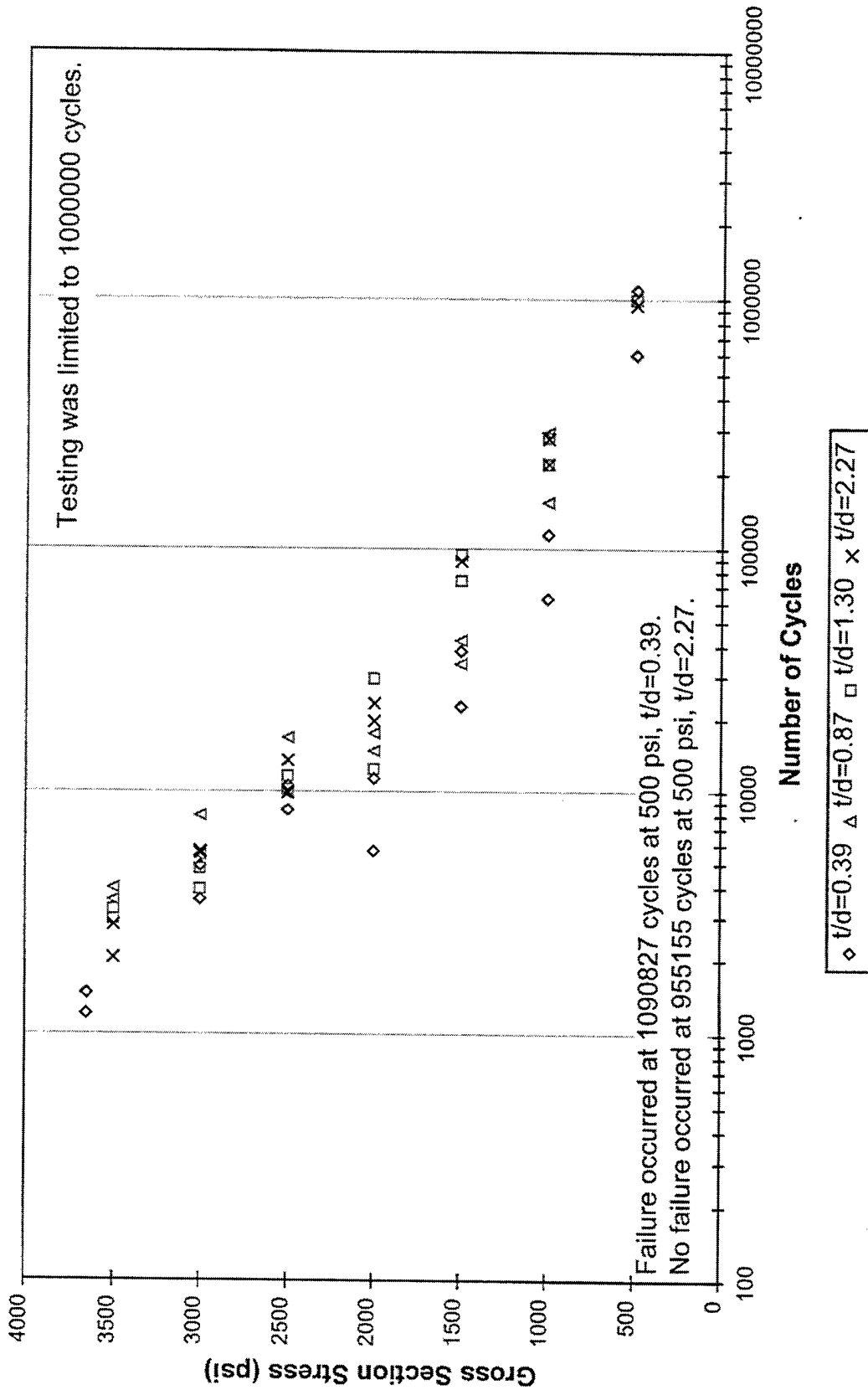
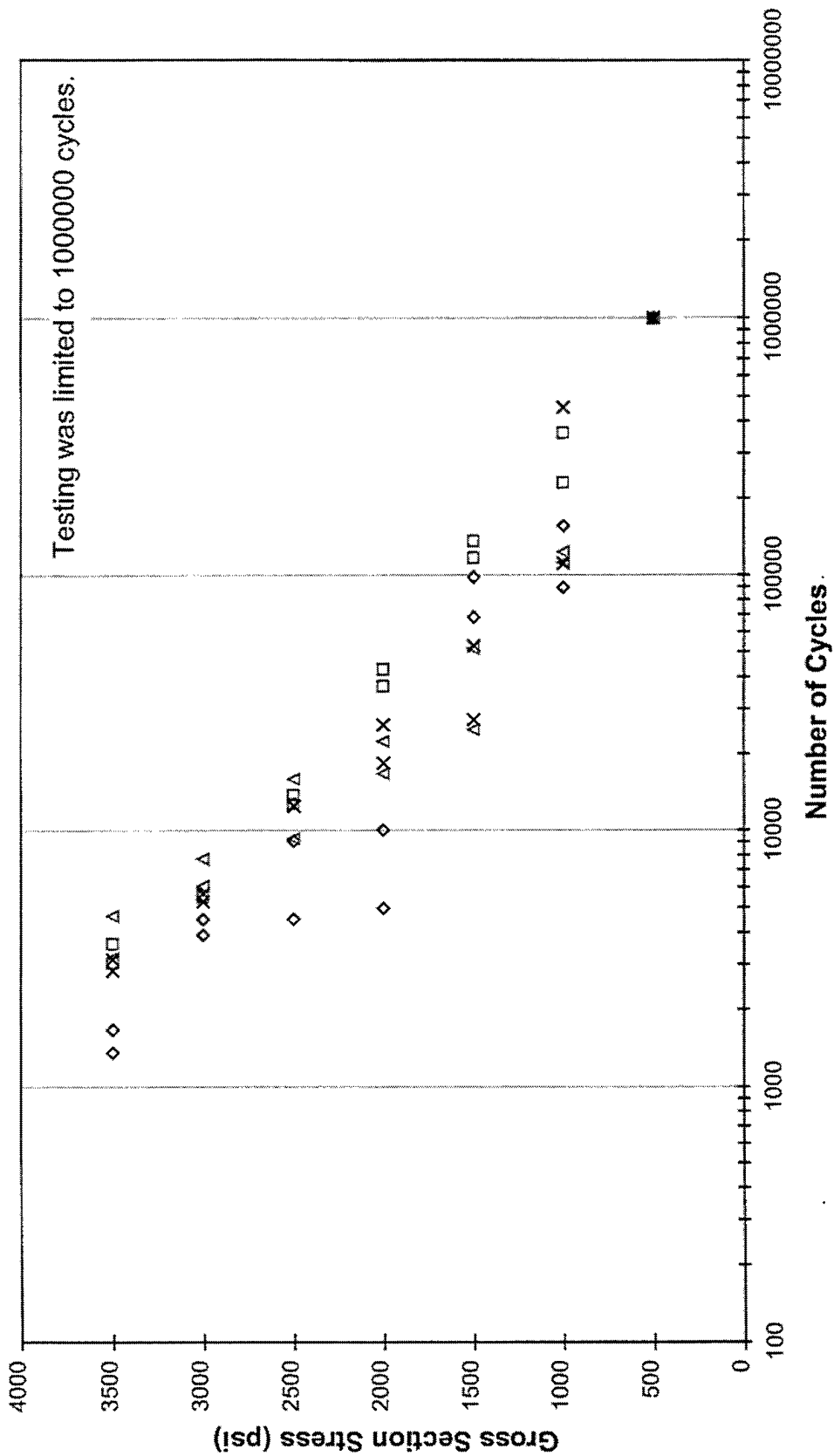

Figure 11. Test Results for Specimens with 10 Percent Cold Working.

# 12 PERCENT COLD WORK COMPARISON



◇  $t/d=0.39$  △  $t/d=0.87$  □  $t/d=1.30$  ×  $t/d=2.27$

Figure 12. Test Results for Specimens with 12 Percent Cold Working.

# 14 PERCENT COLD WORK COMPARISON

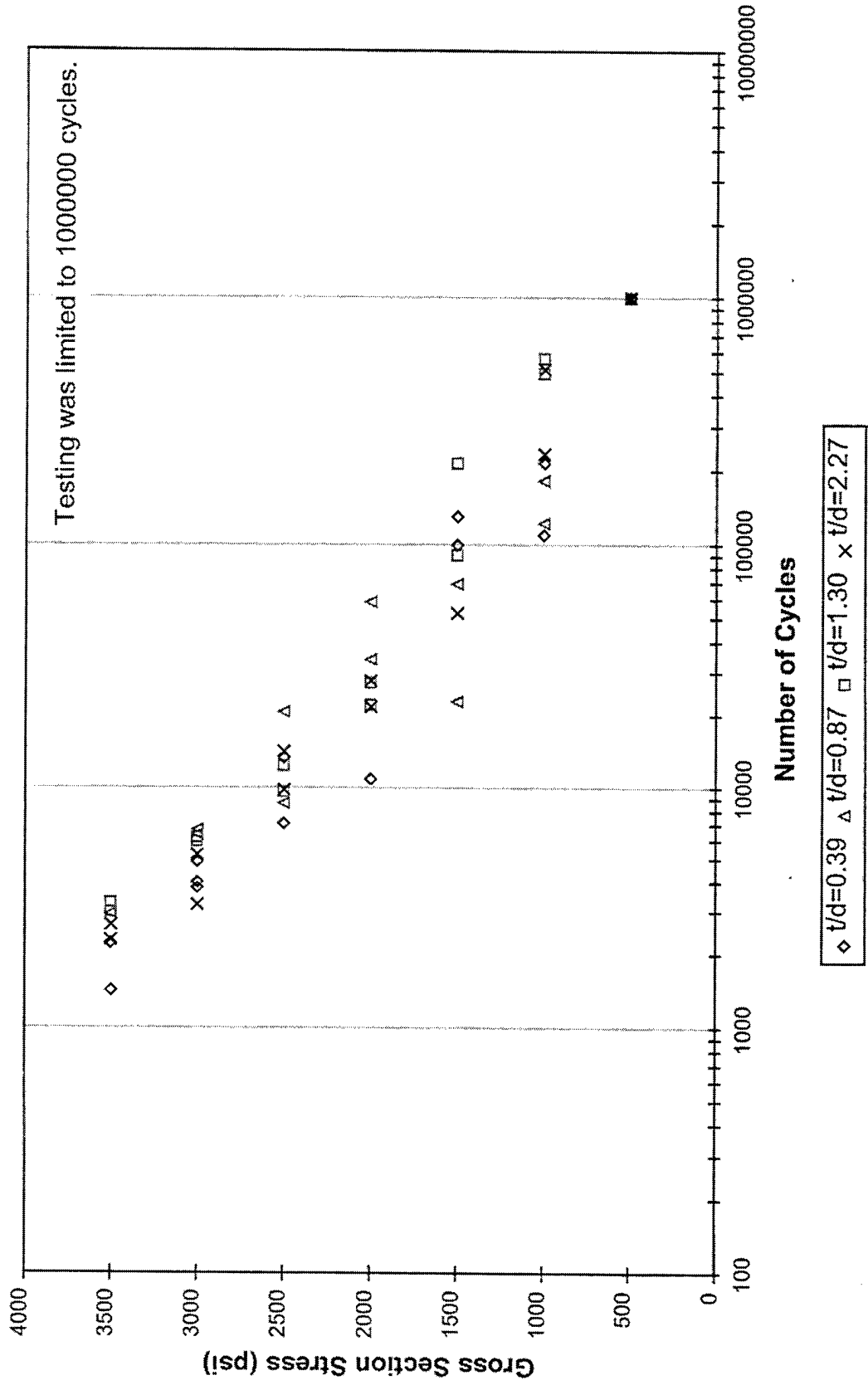
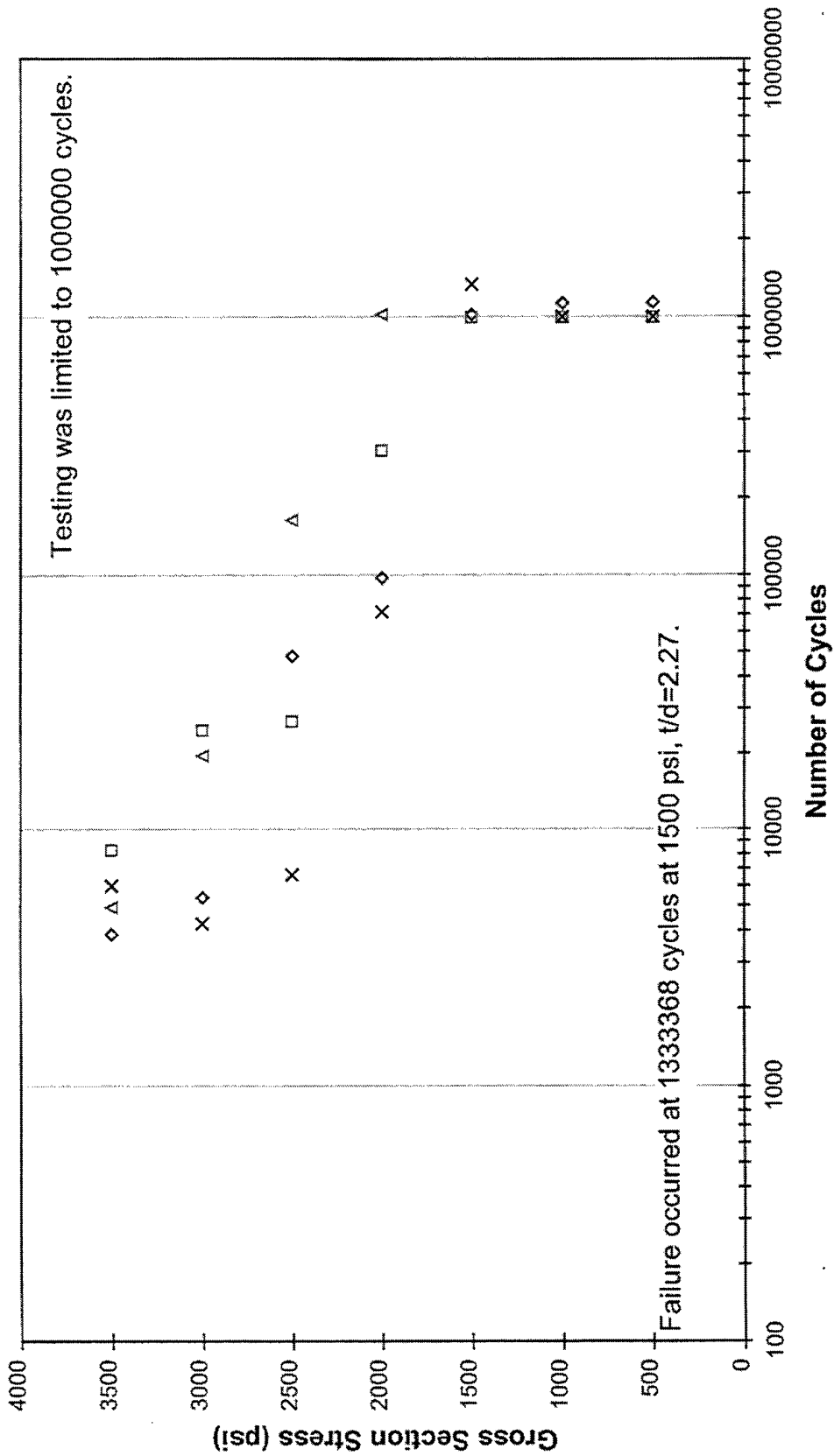

Figure 13. Test Results for Specimens with 14 Percent Cold Working.

### 3 PERCENT INTERFERENCE FIT BUSHING COMPARISON



$\diamond$   $t/d=0.39$   
  $\Delta$   $t/d=0.87$   
  $\square$   $t/d=1.30$   
  $\times$   $t/d=2.27$

Figure 14. Test Results for Specimens with 3 Percent Interference Fit Bushings.

# 6 PERCENT INTERFERENCE FIT BUSHING COMPARISON

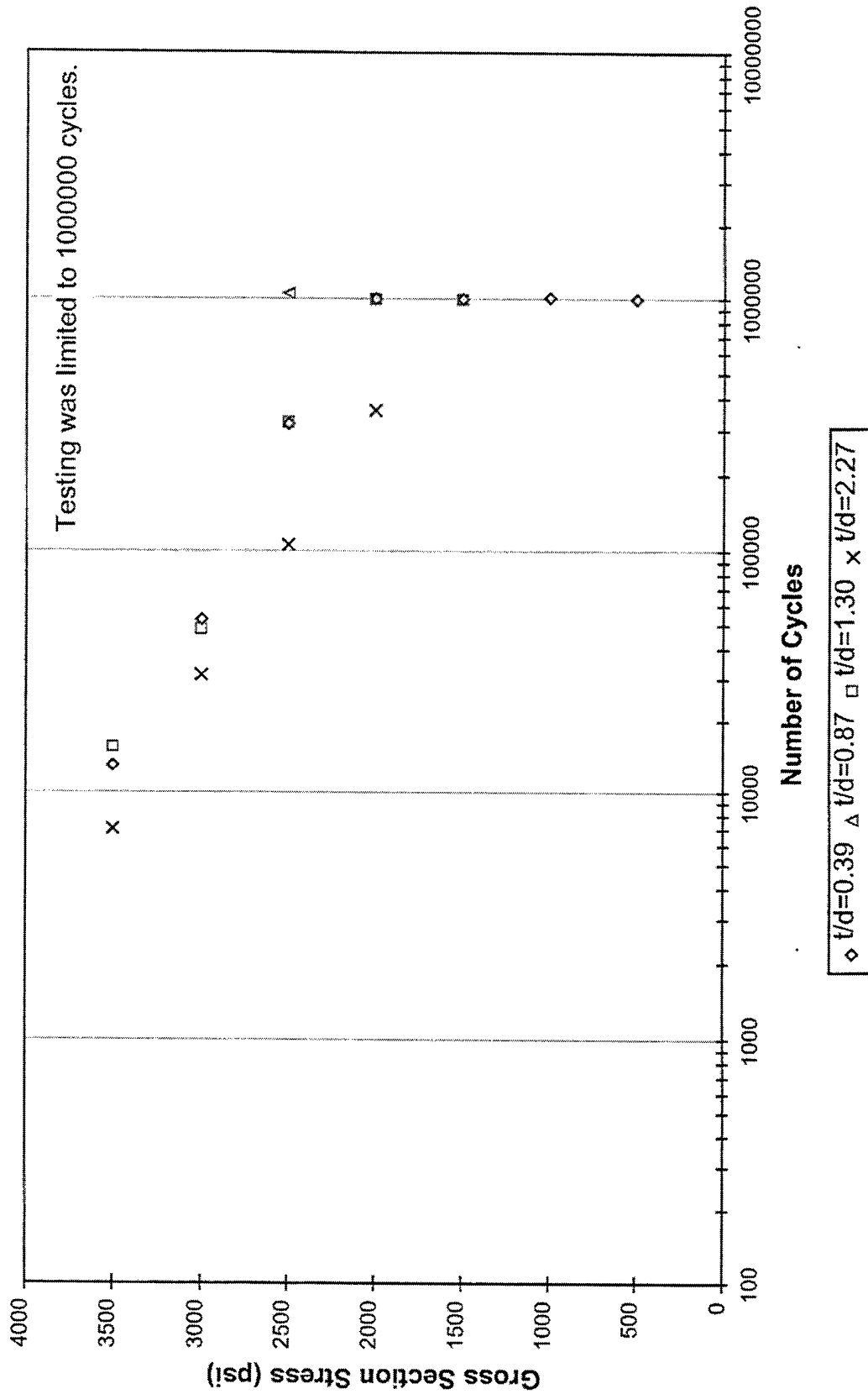

Figure 15. Test Results for Specimens with 6 Percent Interference Fit Bushings.

# 9 PERCENT INTERFERENCE FIT BUSHING COMPARISON

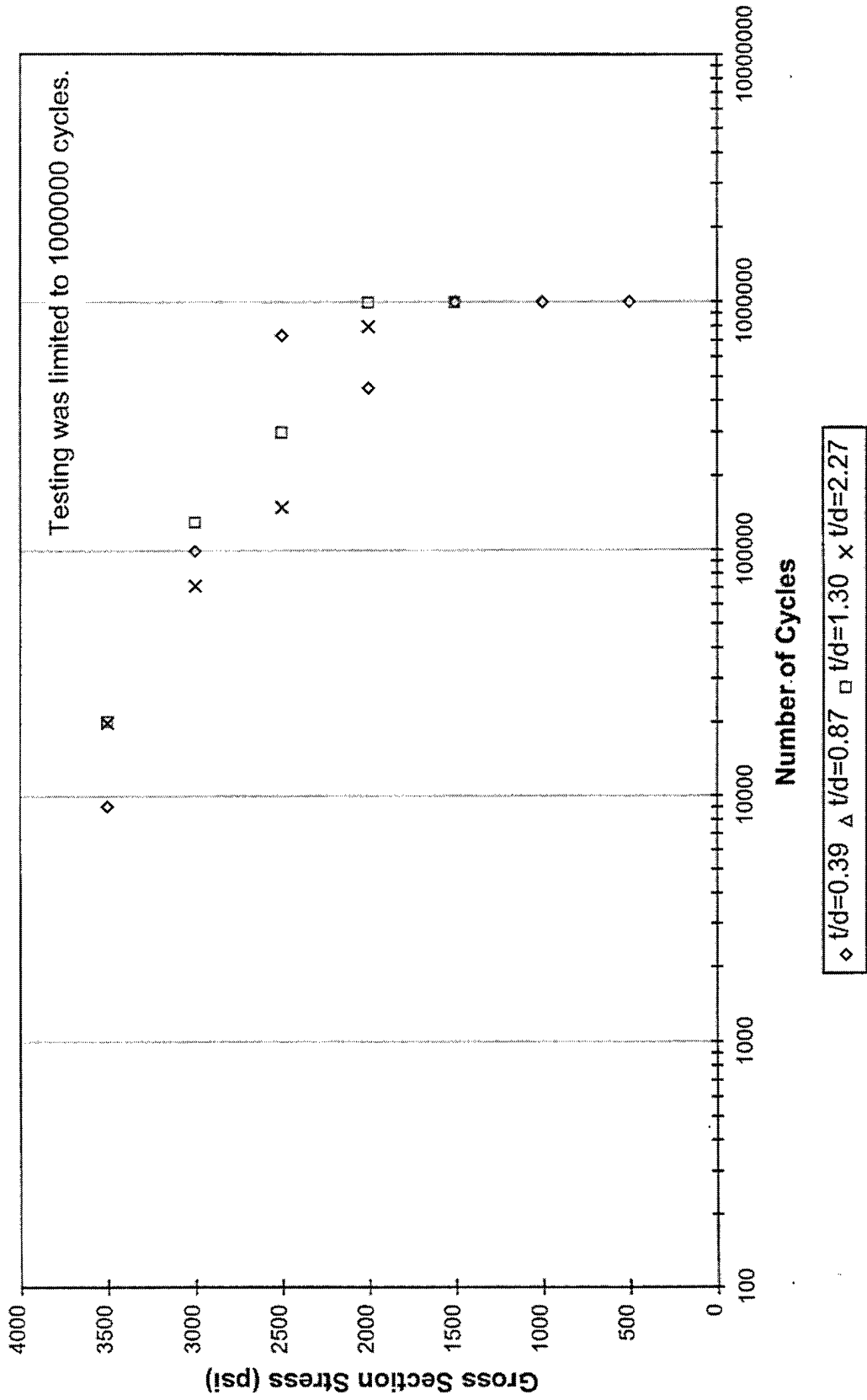

Figure 16. Test Results for Specimens with 9 Percent Interference Fit Bushings.

## SECTION 5 - CONCLUSIONS AND RECOMMENDATIONS

---

Loaded hole testing was conducted on various sheet thicknesses of polycarbonate specimens with holes. Clearance-fit aluminum bushings were used in the holes for baseline and cold worked specimens while interference fit bushings were used in the holes of the interference fit specimens. The goal of the specimen configuration was to represent a characteristic aircraft edge attachment.

Three percentages of cold working were used for this program: 10 percent, 12 percent, and 14 percent, and three percentages were used for sizing the interference bushings: 3 percent, 6 percent, and 9 percent. The percentages were based upon the size of the hole that was drilled in the specimen. Three specimens thicknesses were used: 0.150-inch thick, 0.500-inch thick, and 0.875-inch thick. Finally, two hole diameters were used: 0.386-inch and 0.578-inch.

The following conclusions were made based upon the testing conducted under this effort:

- The cold working process improved the fatigue life compared to baseline specimens. An increase in the fatigue life of roughly one order of magnitude resulted from cold working the specimens. An increase in the cold working percentage generally resulted in an increase in the fatigue life.
- The use of interference fit bushings significantly improved the fatigue life compared to the baseline specimens. An increase of better than two orders of magnitude resulted from the use of interference fit bushings. An increase in the interference percentage generally resulted in an increase in the fatigue life.
- The greatest improvement in fatigue life was achieved through the use of interference fit bushings. The data indicates that the optimum interference percentage is between 6 and 9 percent.
- No significant trends in fatigue life were found for the sheet thickness-to-hole diameter ratios ( $t/d$ ) that were tested for this effort. The  $t/d$  ratios ranged from 0.39 to 2.27. The use of cold working and interference fit bushings is applicable over a wide range of  $t/d$  ratios.
- Similar results were found for both hole sizes and for all thicknesses.

The following recommendations are made based upon the testing conducted under this effort:

- UDRI recommends that interference fit bushings be used to improve the fatigue life of bolt holes on polycarbonate aircraft transparencies. The recommended interference level is on the order of 6 percent regardless of the sheet thickness or hole size.
- The use of interference fit bushings resulted in a tremendous improvement in the fatigue life of polycarbonate specimens with holes; however, stresses exist near the hole that may have a negative effect on the durability or structural integrity of the material. It is recommended that testing be conducted to investigate the durability of edge attachments which include interference fit bushings. Chemical stress craze resistance of the edge attachment is of significant importance. It is anticipated that a properly sealed edge attachment would provide adequate protection from chemical attack. Also, birdstrike testing should be conducted to investigate the effects of the interference fit bushings on the structural integrity of the material.
- It is recommended that manufacturing techniques be developed in order to transition the laboratory use of interference fit bushings into production.

## SECTION 6 - REFERENCES

---

1. Bowman, Daniel R. (1993). An Experimental Evaluation of the Effect of Hole Fabrication/Treatment Techniques on Residual Strength and Fatigue Life of Polycarbonate Specimens with Holes (WL-TR-93-3086). University of Dayton Research Institute.
2. Brot, A. and A. Nathan. (1985). Increasing Fatigue and Crack Growth Lives of Short Edge Margin Holes. Proceedings of the 13th Symposium on Durability and Damage Tolerance in Aircraft Design (pp. 229-245), Pisa, Italy, May 22-24. Warley, England: Engineering Materials Advisory Services, Ltd.
3. Ozelton, Malcolm W. and Timothy G. Coyle. (1985). Fatigue Life Improvement by Cold Working Fastener Holes in 7050 Aluminum. Proceedings of the Symposium on Fatigue in Mechanically Fastened Composite and Metallic Joints (pp. 53-71), Charleston, SC, March 18-19. Philadelphia, PA: American Society for Testing and Materials.
4. Coombe, T. and R. B. Urzi. (1980). Critically Loaded Hole Technology Pilot Collaborative Test Program - Final Technical Report. (AGARD Report No. 678). Harford House, London: Technical Editing and Reproduction Ltd.
5. Schwarmann, L. Influence of Cold Working and Interference Fit on Fatigue Life. (1986). Proceedings of the International Conference on Fatigue Prevention and Design, (pp. 115-121), Amsterdam, Netherlands, April 21-24. Warley, England: Engineering Materials Advisory Services, Ltd.
6. Phillips, Joseph L. (1973). Fatigue Improvement by Sleeve Cold Working. Society of Automotive Engineers National Aerospace Engineering and Manufacturing Meeting. Los Angeles, California. October 16-18.