

[REDACTED]

DEVELOPMENT OF A ROTARY ENGINE POWERED APU FOR A MEDIUM DUTY HYBRID SHUTTLE BUS

INTERIM REPORT TFLRF No. 316

By

Scott T. McBroom
U.S. Army TARDEC Fuels and Lubricants Research Facility (SwRI)
Southwest Research Institute
San Antonio, TX

Prepared for

Defense Advanced Research Projects Agency
3701 N. Fairfax Drive
Arlington, Virginia

Under Contract to
U.S. Army TARDEC
Petroleum and Water Business Area
Warren, MI

Contract No. DAAK70-92-C-0059

Approved for public release; distribution unlimited

July 1998

19980727 161

Disclaimers

The findings in this report are not be construed as an official Department of the Army position unless so designated by other authorized documents.

Trade names cited in this report do not constitute an official endorsement or approval of the use of such commercial hardware or software.

DTIC Availability Notice

Qualified requestors may obtain copies of this report from the Defense Technical Information Center, Attn: DTIC-OCC, 8725 John J. Kingman Road, Suite 0944, Fort Belvoir, Virginia 22060-6218.

Disposition Instructions

Destroy this report when no longer needed. Do not return it to the originator.

REPORT DOCUMENTATION PAGE

Form Approved
OMB No. 0704-0188

Public reporting burden for this collection of information is estimated to average 1 hour per response, including the time for reviewing instruction, searching existing data sources, gathering and maintaining the data needed, and completing and reviewing the collection of information. Send comments regarding this burden estimate or any other aspect of this collection of information, including suggestions for reducing this burden, to Washington Headquarter Services, Directorate for Information Operations and Reports, 1215 Jefferson Davis Highway, Suite 1204, Arlington, VA 22202-4302, and to the Office of Management and Budget, Paperwork Reduction Project (0704-0188), Washington, DC 20503.

1. AGENCY USE (Leave blank)	2. REPORT DATE July 1998	3. REPORT TYPE AND DATES COVERED Interim July 1995 - July 1996	
4. TITLE AND SUBTITLE Development of a Rotary Engine Powered APU for a Medium Duty Hybrid Shuttle Bus			5. FUNDING NUMBERS DAAK70-92-C-0059 WD 36
6. AUTHOR(S) McBroom, Scott T.			
7. PERFORMING ORGANIZATION NAME(S) AND ADDRESS(ES) U.S. Army TARDEC Fuels and Lubricants Research Facility (SwRI) Southwest Research Institute P.O. Drawer 28510 San Antonio, Texas 78228-0510			8. PERFORMING ORGANIZATION REPORT NUMBER Ir 316
9. SPONSORING/MONITORING AGENCY NAME(S) AND ADDRESS(ES) U.S. Army TACOM U.S. Army TARDEC Petroleum and Water Business Area Warren, Michigan 48397-5000			10. SPONSORING/MONITORING AGENCY REPORT NUMBER
11. SUPPLEMENTARY NOTES			
12a. DISTRIBUTION/AVAILABILITY			12b. DISTRIBUTION CODE
13. ABSTRACT (Maximum 200 words) Under contract to the TARDEC Petroleum and Water Business Area, sponsored by the Defense Advanced Research Projects Agency, SwRI has procured and installed a rotary Auxiliary Power Unit on a medium-duty series hybrid electric bus. This report covers the specification and distillation of the APU and the lessons learned from those efforts.			
14. SUBJECT TERMS Auxiliary Power Unit APU Series Hybrid Rotary Engine Passenger Bus			15. NUMBER OF PAGES 23
			16. PRICE CODE
17. SECURITY CLASSIFICATION OF REPORT	8. SECURITY CLASSIFICATION OF THIS PAGE	19. SECURITY CLASSIFICATION OF ABSTRACT	20. LIMITATION OF ABSTRACT

EXECUTIVE SUMMARY

Objective: Under contract with the Defense Advanced Research Projects Agency (DARPA), Southwest Research Institute (SwRI) was tasked to develop a rotary engine auxiliary power unit (APU) for a series-hybrid, medium-duty passenger bus.

This project was initiated in early August 1994. All participants (Southwest Research Institute [SwRI], AVS and Alturdyne) agreed on a target date of early October 1994 for the DARPA Tri-Annual Meeting in Vermont. The goal was to provide a working hybrid bus to demonstrate at the meeting. This objective forced a tight schedule and drove many of the decisions during this project.

Approach: Alturdyne, Inc. of San Diego, California was subcontracted by SwRI to build the rotary APU using liquid petroleum gas (LPG). For the application of this APU to a medium duty bus, SwRI has a working agreement with Advanced Vehicle Systems (AVS), an electric bus manufacturer in Chattanooga Tennessee. This agreement is structured under DARPA, with whom AVS has a separate contract.

Because of resource support problems with AVS and malfunctions in our data acquisition system, there has been very little data collected. However, a good analysis of APU control basics and actual performance observations is included in this report. The following recommendations and conclusions may be made based on the limited data and anecdotal information from AVS and Alturdyne.

Accomplishments: The following statements describe the system developed and lessons learned.

- The maximum APU output power of a 25 kW engine was limited to 13.8 kW to protect the batteries already in service. A battery controller should be installed as the current limiter, not the engine.
- A different motor controller or some power-conditioning device between the motor controller and the APU/Battery power supply should be used to prevent over voltaging the controller.
- A microprocessor APU control unit would allow a more complex and flexible control scheme, including a means to budget the APUs energy. Furthermore, a separately packaged control unit may allow for a more flexible installation, and could be remotely mounted.
- Further design efforts should be based on buses that can accommodate an APU unit in the rear section. The back of the bus would be a better location for the APU. It would be more isolated from the passenger compartment and closer to the radiators. This would also reduce the length of exhaust tubing required.

It is not recommended that a following APU be produced for AVS until it demonstrates that it has the time and personnel to support such a project. If AVS is still interested in getting the first unit to perform as hoped, we recommend that it work in partnership with Alturdyne to achieve mutually desirable results. We believe that the potential for this APU has not been fully realized.

FOREWARD/ACKNOWLEDGMENTS

I would like to acknowledge Scott Duffy, Ed Broze, and Frank Verbeke at Alturdyne who did an excellent job in building the APU with such a short turnaround. I would also like to acknowledge Brian Cox, formerly with AVS, who did an excellent job of facilitating this project.

TABLE OF CONTENTS

<u>Section</u>	<u>Page</u>
1.0 INTRODUCTION	1
2.0 BACKGROUND	1
3.0 SPECIFICATIONS OF THE APU.....	3
3.1 The Application	3
3.2 Location	5
3.3 Enclosure.....	5
3.4 APU Control	7
3.4.1 Control Development.....	7
3.4.2 Control Lessons Learned	8
3.5 Generator and Power Conditioning Specifications.....	10
3.6 Engine Specifications.....	10
3.6.1 Fuel	10
3.6.2 Lubrication.....	11
3.6.3 Starting.....	11
3.6.4 Power	11
3.6.5 Generator Drive.....	12
3.6.6 Cooling.....	12
3.7 Driver Interface	13
4.0 INSTALLATION	13
4.1 Acceptance.....	13
5.0 DATA ACQUISITION.....	15
5.1 Data Logger Hardware.....	16
5.2 Data Logger Installation	16
5.3 Sensors	18
6.0 OBSERVATIONAL DATA.....	20
7.0 RECOMMENDATIONS AND CONCLUSIONS	21
7.1 Control Approach.....	21
7.2 Mechanical Components.....	22
7.3 Installation.....	23

TABLE OF CONTENTS (cont)

APPENDICES

- A. Alturdyne Information
- B. AVS Information
- C. Electronic Wiring Diagrams for Alturdyne APU
- D. Thermocouple Assignments
- E. Analog Channel Assignments
- F. Current-Sensor PIN Assignments
- G. Brake and Accelerator Pedal Function
- H. Color-Coded Line for Frequency-to-Voltage Modules
- I. Adtech Isolated Power Converter
- J. NEMA Enclosure

LIST OF ILLUSTRATIONS

<u>Figure</u>		<u>Page</u>
1.	Location of APU in Front-Most Compartment.....	5
2.	APU in Enclosure Box Fitted Into Bus Envelope.....	6
3.	APU Charging Current at Constant Voltage.....	9
4.	Hardware Locations on AVS Bus.....	17
5.	Current Sensor Placement and Orientation.....	19
6.	Brake and Accelerator Pedal Position.....	20

LIST OF TABLES

<u>Table</u>		<u>Page</u>
1.	AVS, Electric Bus 708 Original Specifications.....	4
2.	Noise Comparison.....	14

1.0 INTRODUCTION

Under contract with the Defense Advanced Research Projects Agency (DARPA), Southwest Research Institute (SwRI) was tasked to develop a rotary-engine, auxiliary power unit (APU) for a series-hybrid, medium-duty passenger bus. The engine must use either propane or compressed natural gas.

This project was divided into three phases. Phase I was the specification and construction of the APU. Phase II was the installation of the APU on the bus, and Phase III was the collection of performance data from the vehicle and the APU. Phase I is explained in Section 3.0 of this report "SPECIFICATIONS OF THE APU." Phase II is detailed in Section 4.0, "INSTALLATION." Finally, Phase III is reported in Section 5.0, "DATA ACQUISITION."

Alturdyne, Inc. of San Diego, California was subcontracted by SwRI to build the rotary APU using Liquid Petroleum Gas (LPG). To apply this APU to a medium duty bus, SwRI created a working agreement with Advanced Vehicle Systems (AVS), an electric bus manufacturer in Chattanooga, Tennessee. This agreement is structured under DARPA, with whom AVS has a separate contract.

2.0 BACKGROUND

As a part of the DARPA task order, SwRI was contracted to develop natural gas APUs. In this assignment, a rotary engine APU from Alturdyne was selected. This project developed from DARPA's desire to get a working hybrid bus on the road to demonstrate and develop the technology. AVS was working on a different contract and volunteered to provide the vehicle for this demonstration.

Alturdyne is a generator set manufacturer located in San Diego, California (Appendix A). It primarily manufactures stationary standby units. Their APUs are unique because they are Wankel (rotary) engines, based on the Mazda trochoid and liner. These parts are supplied under

an agreement from Mazda. Alturdyne then manufactures the end plates and the intake and exhaust system. The resulting product is substantially American made. These engines have high power density, are modular, and are available from one, up to four, rotor units (Table A1)¹.

The naturally aspirated single rotor engine used for this project (Table A1, column 1) can produce 25 kW, is water and oil cooled, and can burn either LPG or natural gas. Engine data using natural gas is provided in Appendix A. The trochoid combustion seals must be lubricated with oil for extended life. Maintenance and oil consumption can be found in Table A2. The engine running on LPG gas not been tested for emissions. A graph of emissions at wide-open throttle, running on natural gas, is shown in Figure A2. Alturdyne has not developed any significant emissions control. The majority of its applications are stationary, and do not yet require controls. No exhaust after-treatment devices, such as catalytic converters or thermal combusters, are used on the APU. The alternator selected by Alturdyne for this application is a wound-field armature, AC-induction unit originally developed for aircraft use.

AVS is a small, electric-bus manufacturer located in Chattanooga, Tennessee (Appendix B). AVS is a start-up company, an off-shoot from Specialty Vehicle Manufacturing Corporation (SVMC) in Downey, California. It currently produces three vehicles: 22, 29, and 31-foot electric buses. When this project began, AVS was using Chloride Electronetwork Systems to supply the Nelco DC motors, motor controllers, accelerator pedals, and batteries. The buses are made using a low-carbon steel frame, wooden floors and bulkheads, and fiberglass exterior panels.

This project was initiated in early August 1994. All participants agreed on a target date of early October 1994 for the DARPA Tri-Annual Meeting in Vermont. The goal was to demonstrate a working hybrid bus at the meeting. This objective forced a tight schedule and drove many of the decisions during this project.

¹ If figure and table references include a letter, the letter represents the appendix, and the number indicates chronological order within the appendix.

3.0 SPECIFICATIONS OF THE APU

AVS strives to meet the needs of their customers. Feedback on the electric version of this bus indicated that the customers would like air conditioning and an increased range to 100 miles. The desired improvements for a series-hybrid bus compared to the electric version are as follows:

- air conditioning (the electric bus has none)
- 100-mile range with the air conditioning (the electric bus has a 60-mile range with air conditioning)
- heating (the electric bus uses a propane heater)
- the perception by the passengers that this is still an electric bus

3.1 The Application

AVS selected bus 708 for the conversion. Bus 708 is the most up-to-date, 22-foot bus, sold to and operated by the Chattanooga Area Transit Authority (CARTA) in downtown Chattanooga. Use of this bus was possible because CARTA and AVS participate in a Federal Transit Authority (FTA) working laboratory. The FTA provides CARTA with funds to purchase and operate an electric bus demonstration fleet for the purpose of refining the buses and the infrastructure. Under this program, CARTA agreed to let AVS and SwRI convert bus 708 to a series hybrid, yet required that the bus remain in service without lengthy interruption. Table 1 shows the information on bus 708 prior to conversion.

TABLE 1. AVS, Electric Bus 708 Specifications	
Drive Train	<p>Overall gear reduction of 12.2:1 (at the axle shaft) Dana diff.: 7.2:1 BMI, Single speed trans. (pulley's w/Kevlar belt): 1.7:1 Motor top speed 5,600 rpm Rolling radius: 15 inches Drive shaft with U-joints between the motor and the drive pulley Calculated maximum drive train efficiency: 75 %</p>
Accessories	<p>Power supply for 12 Volt system: Two, 216V DC to DC converters, 30 A each, in parallel, 60 A peak Pneumatic system (Separate motor drive): Air compressor – Gast air compressor, model pcd-10 Motor – 216 V, Solectria motor/controller, single speed on/off to maintain 70 to 90 psi in reservoir Brakes – Mico air over hydraulic Steering – Air-o-matic/Sycon air assist Suspension – Air bag: New Way suspension leveling valve, ride height only Door – pneumatic cylinder</p>
Electronics	<p>Purchased a complete system from Chloride Motor controller is Chloride Electronetwork. Chloride controller has its own built-in SOC measurement. Voltage measures open circuit during no-load condition. Controller designed specifically for the Nelco motor: 32 kW. Battery Pack, 216 V – 300 Ahr (C/5) batteries from Chloride. Use Chloride battery charging system Regenerative braking is incorporated.</p>

For this initial demonstration, the project funding did not include purchasing an air-conditioning system. The air-conditioning requirement was dropped. It was decided that the first APU would provide range extension only. Pending results of this prototype APU, a second APU would then be specified, its characteristics based on information gained from running the first.

To develop the APU specifications, SwRI worked with Alturdyne and AVS to determine the location of the APU on the bus, sound-proofing, the operational modes, the required power, driver interface, and APU installation (e.g. cooling). The details of the specifications are outlined in the sections that follow.

3.2 Location

The location of the APU on the bus had to be large enough to fit the APU and its enclosure. Additionally, it had to be accessible for maintenance. Two places were identified by AVS. The most desirable spot was at the back of the bus, but it would require too much time to implement by the October deadline. The second choice, the side compartment, was easier to implement but a less desirable placement.

As shown in Figure 1, the APU was located in a side compartment of the bus facing the curb, measuring 193.4 cm x 86.4 cm. This compartment originally held the propane heater and brake boosters for the electric bus. The heater was removed, and the brake boosters shown in the photograph were relocated.

3.3 Enclosure

An enclosure was built to minimize noise, vibration, and visual impact of the APU on passengers and pedestrians (Figure 2). Exhaust out of the box is large-diameter, double-insulated tubing,



Figure 1. Location of APU is in the front-most compartment.

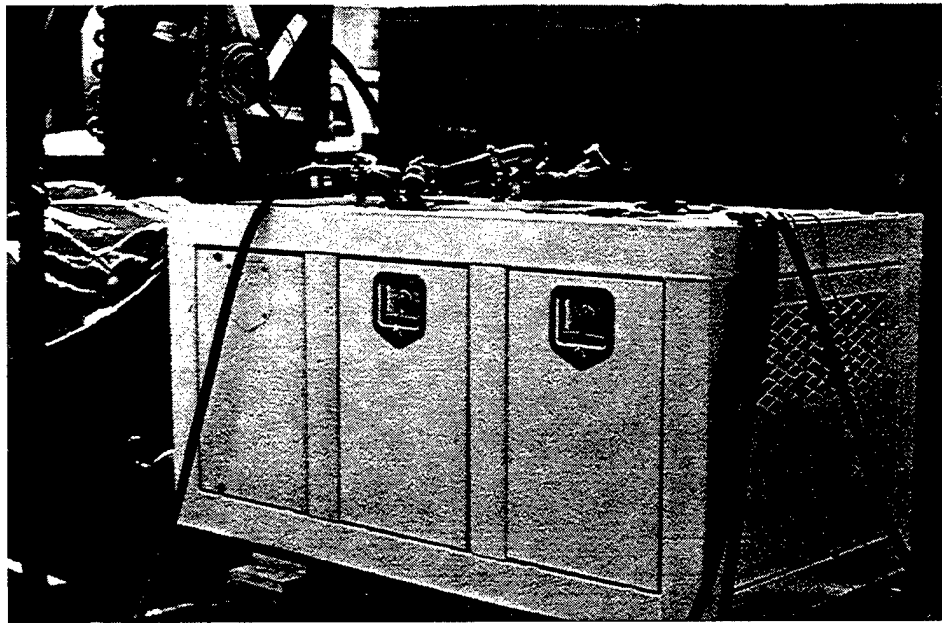

Figure 2a. APU in enclosure box fitted into bus envelope, APU enclosure

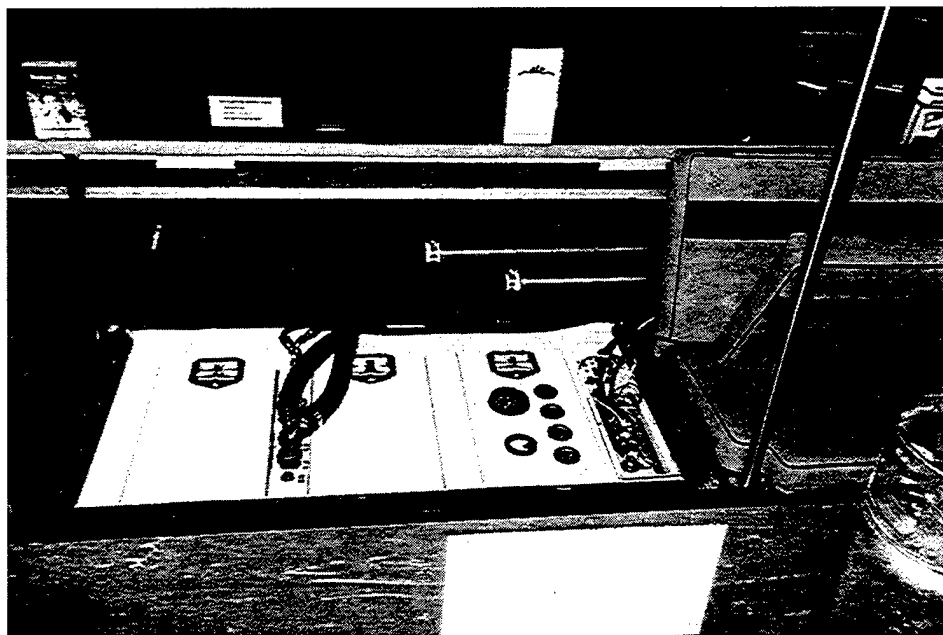

Figure 2b. APU in enclosure box fitted in bus envelope, view from interior with seats removed

which exits the APU enclosure from the rear facing panel. The exhaust is then routed, using conventional exhaust tubing to the rear of the bus. The air intake is hidden, snorkeling from the side panel back to the carburetor, making a 180 degree turn, then passing through a noise-insulated panel. To reduce vibration, the engine is mounted on rubber pads inside the enclosure. The generator is insulated from the engine and shielded inside the enclosure to minimize electromagnetic interference. To keep the package small, the radiator and oil heat exchanger were not required to be located on the enclosure and are mounted remotely. The enclosure is fabricated from thin wall aluminum square tubing and aluminum sheet metal, which was perforated on the inside. The panels are filled with sound and heat-insulating fiberglass. A circulation fan provides localized cooling inside the enclosure.

3.4 APU Control

The APU controller is a relay logic circuit design (see circuit diagram in Appendix C). This design was chosen over a programmable logic controller due to time constraints as seen by Alturdyne. The control of the APU is described next.

3.4.1 Control Development

When the driver turns on the APU, he/she is actually turning on the APU controller (12 VDC @ 5 amps). The APU controller determines whether to turn the engine on or off based on the battery state of charge. Battery state of charge is obtained from a proportional voltage (0-10V) signal provided by the Chloride Electronetwork motor controller.

In this simple charging scheme the batteries are permitted to discharge until they reach a chosen lower threshold state of charge. At this point the APU controller will turn on the engine. If the engine and generator can produce power in excess of road load demands, the batteries will charge. The batteries charge until they reach some chosen upper threshold limit. At this point, the APUcontroller will turn the engine off.

To determine the upper threshold limit, one must allow enough capacity in the battery to handle regenerative braking power and minimize the charging losses. Typically, in lead acid batteries like those used on bus 708, charging losses increase dramatically above 90-percent state of charge.

To determine the lower threshold state of charge one must consider battery life and charging rate. For lead acid batteries like those used in bus 708, there is a general relationship between the depth of discharge and the cycle life. A battery cycled between 100 and 20-percent state of charge will not last as long as a battery cycled between 80 and 50-percent state of charge. Also, the deeper the battery is discharged, the longer it will take to charge. When one is concerned about the emissions produced by an APU, the desire is to minimize the time that the engine is on and still achieve the desired range.

3.4.2 Control Lessons Learned

While trying to determine the charging rate of the batteries, two limiting factors were discovered. First, the Chloride lead acid batteries cannot accept more than 40 amps for periods longer than a minute without gassing. Second, the Chloride Electronetwork motor controller cannot accept greater than 235 VDC input without failure. These factors limit the upper and lower thresholds as described below.

The upper threshold was determined from the voltage limit. As the battery state of charge increases, so does its voltage potential. In order to get current flow into the battery, the generator must increase the voltage so that it is greater than the battery's voltage. The greater the voltage differential, the more current flows into the battery. The smaller the differential, the less the current flows. If the differential is decreasing as the state of charge increases (as is the case here), then at some point the charging current will not be enough to charge the batteries, and state of charge will not increase. Figure 3 is a graph based on empirical data demonstrating this relationship.

Using Figure 3, if the upper threshold were to be 90-percent SOC, then to get from 85 to 90-percent SOC, the batteries would only accept 15A@85% down to 5A@90%. Given that these are 300Ahr batteries, that would mean going from 255Ahr@85% to 27Ahr@90%, and 15Ahrs would have to be provided. Assuming an average (between 15A and 5A) of 10A, it would take 1.5 hours. This is too long for only 5-percent increase in state of charge. As an initial trial, 85 percent was set as the upper threshold.

The lower threshold is limited by the 40A current limit of the batteries. At a constant 230V and at 60-percent SOC, the voltage differential between the batteries and the generator would create 36A, as shown in Figure 3. It was decided that this was a safe place to start.

Therefore, the basis APU controller function is as follows. Assuming that the bus begins the day at 100-percent SOC, the APU will monitor the SOC until it reaches 60 percent. This is indicated by a 6V (SOC) signal from the motor controller. The relay logic circuit will then latch on, starting the engine. The APU controller will then monitor current to the battery as a function of SOC. If SOC reaches 85 percent, then the APU controller will latch off, stopping the engine.

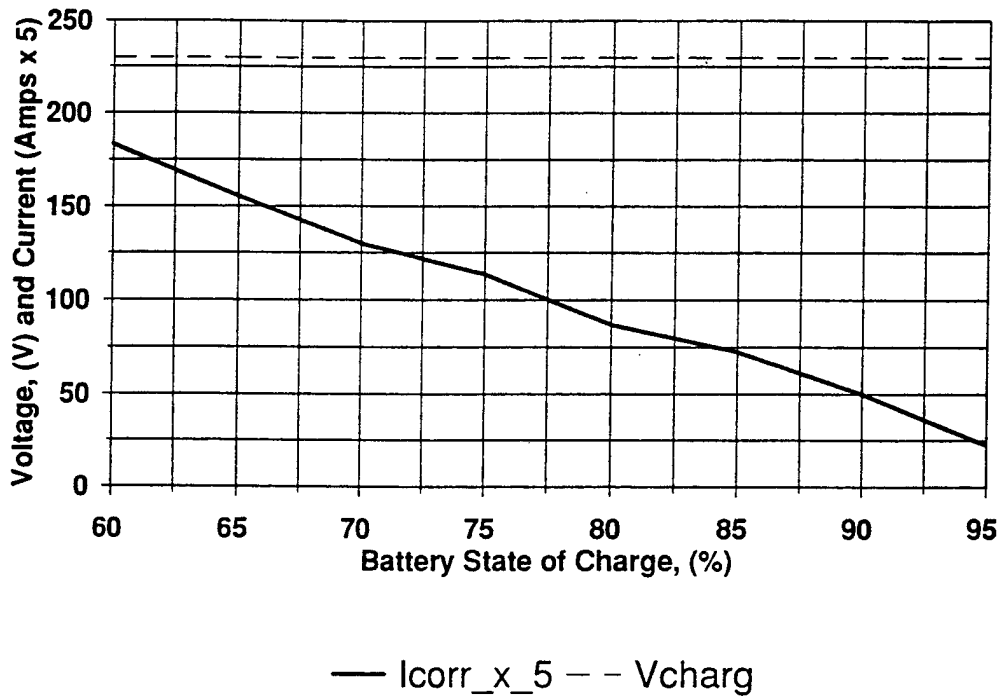

Figure 3. APU charging current at constant voltage

The upper limit stop is achieved by monitoring current output. Above 85-percent SOC, the current demanded by the battery will fall below 15A. The latch relay is adjustable between 15A and 5A. Current is monitored by sensor on the APU generator and feedback to the controller via analogue signal.

While on, the APU controller will maintain the generator at constant speed to achieve the desired maximum constant voltage. The APU controller will adjust the engine throttle to match the load. The APU controller also monitors vehicle speed and accelerator pedal position. When the bus is coasting or braking, the controller will set the APU speed to idle. Since the APU is located curbside, the desire is to have the APU as quiet as possible when the bus comes to a bus stop. This is also advantageous as it maximizes braking.

3.5 Generator and Power Conditioning Specifications

A wound field 55 kW, 400 Hz, aircraft generator was used. The speed of the generator is directly proportional to the voltage. To achieve the desired voltage, 230 V, (as discussed in Section 3.4, APU Control) the generator was set to 6,000 rpm at all times. The AC output is rectified to DC with a 4.2-percent ripple. Peak output voltage due to ripple is $230\text{ V} + (.042/2)(230)=234.8\text{V}$, which does not exceed the 235 V limit of the controller.

3.6 Engine Specifications

3.6.1 Fuel

AVS requested LPG as the APU fuel. They understand that their customers prefer it.

3.6.2 Lubrication

The engine has a 6-quart wet sump. Alturdyne specifies the oil as SAE 30 grade, low ash. Oil must be added every 40 hours of operation (Table A2), as it is consumed by the engine to lubricate the combustion chamber seals.

3.6.3 Starting

The engine requires 12 VDC at 30A for the starter motor. The starter motor could eventually be replaced by adding a motoring capability to the generator.

3.6.4 Power

Engine power is limited to less than the rated 25 kW by the voltage limit of the motor controller (see section 3.4, APU Control) and the current limit of the batteries. Using these limits, the output power of the engine would be (230V x 40A). If we assume an average efficiency of the generator to be 90 percent, the power required from the engine would be 10.2 kW. Because the engine is capable of 25 kW and the generator must be kept at constant speed, the engine is therefore limited to a part throttle operation at higher speeds, which is not very efficient, or a lower speed operation to open the throttle and improve efficiency.

Referencing Figure A1, if the speed is kept low to maintain the engine near wide-open throttle, then the engine speed cannot exceed 2000 rpm (10.2 kW=13.7 HP). Figure A2 shows that the maximum CO emissions occur at this point. Figure A2 also shows that the Brake Specific Fuel Consumption (BSFC, lb/hphr) is highest at lower engine speeds.

Another factor in determining engine power is that if the batteries are to be charged the APU must produce power in excess of the 10.2 kW (see above) required by the battery for charging. The APU must also put out enough power to meet the road power demands. AVS has determined that the average consumption for a 22-foot electric bus operating on Chattanooga's

downtown shuttle route is 7 kW. Therefore, the power output of the generator set should be $10.2 + 7 = 17.2$ kW. This permits the APU to meet the average road demand by supplying current directly to the motor while continually charging the batteries when in charge mode.

However, without a current-protection circuit for the batteries, if the APU is capable of producing 17.2 kW at 230 V, the battery load could potentially exceed the 75A limit during regenerative braking and lags in the APU controller. As AVS did not want to put their batteries at risk, nor purchase current protection, 17.2 kW was not considered.

However, to even maintain a charge on the batteries, some value greater than 10.2 kW must be chosen. As a compromise, 13.8 kW was initially selected as the average between 10.2 and 17.2 kW. At this power, the maximum potential load into the batteries could peak at 60A. It was planned to evaluate the effectiveness at this power level and change it if necessary. Given the APU control method, the APU was set to idle during coast down and braking. AVS was comfortable that the 40A limit of the battery would not be exceeded for periods larger than a minute, lowering the BSFCs and the CO emissions.

3.6.5 Generator Drive

The engine must provide a maximum of 13.8 kW. At 13.8 kW, wide-open throttle the engine speed is 2,500 rpm. To maintain generator speed at 6,000 rpm, the pulley ratio between the engine and the generator is 2.4. The drive is an HTD (gear tooth) belt-driven system.

3.6.6 Cooling

The water-cooled engine will require 3.8 kW cooling capacity as determined by Alturdyne. To keep enclosure openings and size to a minimum, the radiators are not required to be in the APU enclosure. One-third of cooling capacity is provided by an oil cooler; the remaining cooling is provided by water. Both coolers are located in the back of the bus, street side. This location was selected to minimize noise from the cooling fans and to hide any evidence of an engine on board

the vehicle. The disadvantages to this location is that approximately 3 meters of cooling lines must be run. This makes bleeding the lines difficult. The oil cooler uses a 12 V pump to circulate oil.

3.7 Driver Interface

A key switch is located in the driver's console to activate the APU. Turning the key on does not turn on the engine, but turns on the APU controller. This allows the bus to be operated in zero emissions mode at the driver's command. Also in the driver's console are three lights indicating the following malfunctions: loss of oil pressure in the engine, high temperature, and generator failure.

4.0 INSTALLATION

The APU was shipped from Alturdyne in California to AVS in Tennessee, with one week to install the unit and debug it before the October 1994 DARPA Conference. The unit did not fit the envelope. The bus had to be modified by removing a bracket and welding angle iron to the bottom of the bus to serve as the lower supports.

The oil and cooling lines were routed out of the top of the APU, behind the passenger seats to the back of the bus. The radiator and oil heat exchange are located in the far back corner of the bus. The side panel where the radiator was mounted was cut to provide an opening. The air is routed past the radiators under the bus and out the back.

4.1 Acceptance

Unfortunately, AVS felt the APU was too loud and created too much vibration in the passenger compartment for AVS to consider bringing it to the DARPA Conference. The following items were identified by Alturdyne as contributors to the problem:

- The engine speed was producing vibration at some natural frequency harmonic of the APU.
- The enclosure ventilation seals are not adequate.
- An air intake silencer was not used.
- The exhaust tubing may require more isolation.
- The elastomer engine mounts are not adequate.

The APU was returned to Alturdyne, and modifications were made. Upon return of the APU, the bus was noise tested using a hand-held decibel meter. Readings were made on the “dBA” scale while the bus was in electric and hybrid mode, under various conditions, and at different points around the bus. The results are shown in Table 2. The interior noise is measured at the center of the bus at steady-state conditions. The exterior noise is the maximum value obtained from an observer standing five feet from the road/bus.

In the early design stages, it was decided that the APU should idle when approaching a curb, so as not to disturb on-boarding passengers. As later determined, the noise level requirement was very close to what the APU was emitting (Table 2). (The requirement by AVS was that it should “*sound like an electric bus.*”) The result is that it is not necessary to idle the engine while the vehicle is stopped. The APU could then put full power into the batteries, provided the current into the batteries was limited and the controller had overvoltage protection.

TABLE 2. Noise Comparison

Vehicle Speed (mph)	Interior Noise (dBA) Standing in middle of bus		Exterior Noise (dBA) @ 5ft from bus, 4ft off the ground	
	EV mode	Hybrid Mode	EV Mode	Hybrid Mode
Stopped	50 standby 63 w/air compressor on	68 @ idle 71 charging	57 standby 67 w/ air compressor on	72 @ idle 78 charging
10 mph	67	73	72	79
20 mph	73	79	84	86

A 55 kW, 400 Hz aircraft generator was used. The high operating speed and low power made it necessary to belt drive rather than direct drive this generator. The belt drive could be a major source of vibration. Perhaps use of a different generator with lower speed requirement would allow direct drive and reduce noise.

Relay logic was chosen over a microprocessor again due to time constraints. The relay logic circuit does not have the flexibility required to make large changes in the APU control. For example, the upper level cutoff for battery state of charge is limited to 85 to 90 percent. A microprocessor APU control unit would allow a more complex and flexible control scheme, including a means to budget the APU's energy. Furthermore, a separately packaged control unit may allow for a more flexible installation and could be remotely mounted.

Rubber mounts under the APU enclosure would have reduced vibration and noise significantly. Again, the design requirements are still subjective.

A majority of the noise appears to be coming from the exhaust and from some vibration within the APU unit. More attention given to the muffler system would probably solve the noise problem. Future design efforts should be based on buses that can accommodate an APU unit in the rear section in order to move the noise away from most riders.

5.0 DATA ACQUISITION

In the final phase of this project, SwRI set up a remote data acquisition system. It was hoped that the effectiveness of the APU could be monitored from the data, and appropriate changes made to improve vehicle efficiency and utility. Unfortunately, the data logger malfunctioned, and AVS did not have the manpower to assist SwRI in fixing the problem.

The data acquisition was set up to monitor the following:

- Engine Speed
- Vehicle Speed
- Battery Pack Temp (4 places)
- Battery Voltage
- Generator Current
- Battery Current
- Motor Current
- Accessories Current
- Air Compressor Motor Current
- Accelerator Pedal Position
- Brake Pedal Position
- Cabin Temperature
- Outside Air Temperature

5.1 Data Logger Hardware

The Southwest Research Data logger consists of four main components: an industrial computer, an input card, a modem and a cellular telephone. The computer includes a 486 66 Mhz CPU with video and hard drive controllers, 2 megabytes of RAM, and two 1.44 megabyte solid-state discs. The input card includes a 12-bit, A to D converter capable of handling up to 256 data channels. Two multiplexers are used in conjunction to provide 16 analog channels (+/- 10 VDC) and 16 thermocouple channels (K type) for a total of 32 sensor inputs. The modem and cellular telephone work together through a "smart connection" to transmit data at a rate of at least 14.4 bps.

5.2 Data Logger Installation

On the vehicle, the Data Logger is mounted within a "cage" of angle iron, inside the bus frame, suspended just below the rear deck. Four cables protrude from the right end of the Data Logger enclosure. Listed from top to bottom, the cables are as follows: thermocouple input cable, analog input cable, power input cable, and cellular telephone antenna cable.

The end of the thermocouple cable terminates near the auxiliary power 12 V converter. Each of these sixteen pairs ends with a female connector, each of which is numbered consecutively to indicate its channel number. Thermocouple channels 1 to 6 are connected to K-type thermocouples located as shown in Figure 4. The other ten are joined to male connectors whose internal terminals have been jumpered together to prevent electrical "noise."

The end of the analog cable terminates outside the bus, on the right inside wall adjacent to the Data Logger. Each of these sixteen pairs ends at a set of screw terminals, with the first pair nearest the rear of the bus and the last pair nearest the front. Analog channels 1 to 10 are connected to analog signals located as shown in Figure 4. The other six are open.

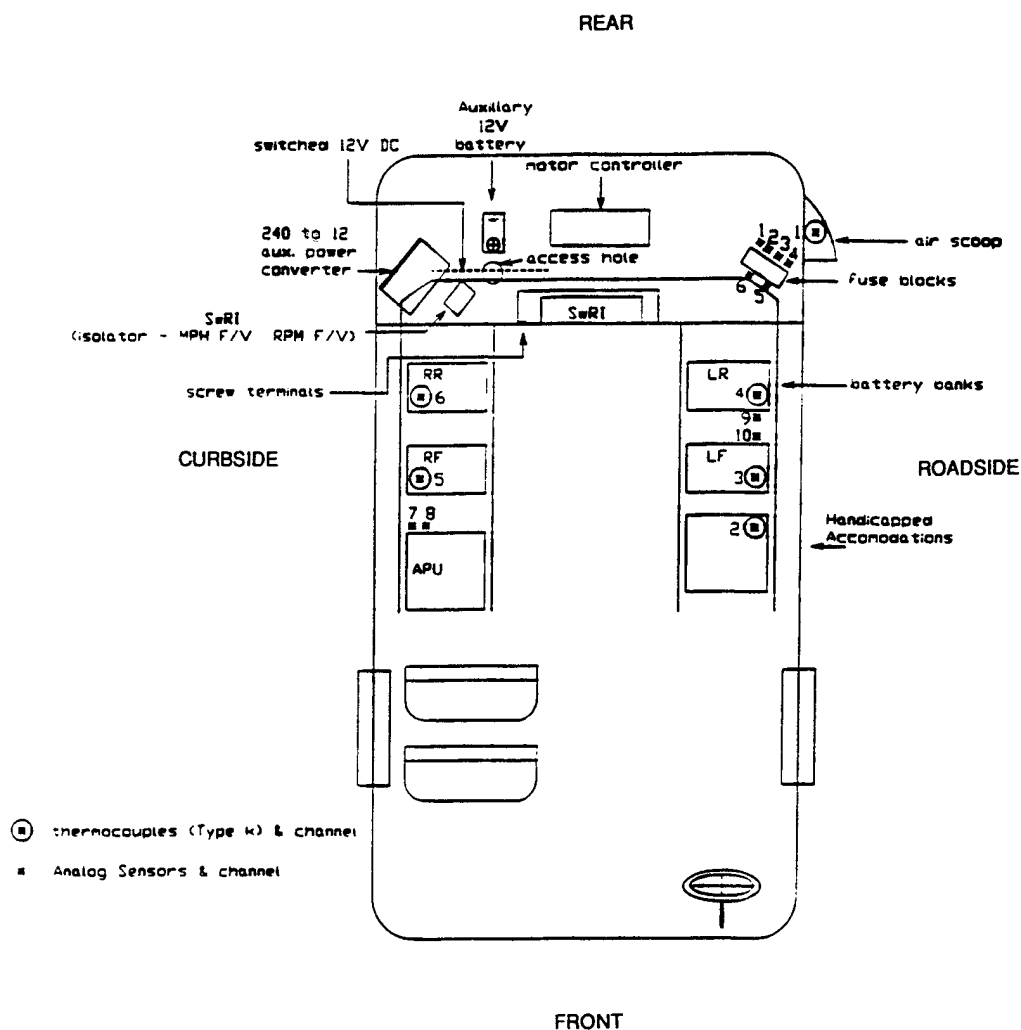

Figure 4. Hardware locations on AVS bus

The power cable contains three separate wires. The red and black wires connect to the positive and negative terminals of the auxiliary power 12 V battery, respectively; and the clear wire connects to the 12 V switched input to the auxiliary power 12 V converter.

Three special modules reside within a small NEMA (National Electric Manufacturers Association) type-12 enclosure located on a bracket just above the auxiliary power 12 V converter. One is an SCT 302 isolated DC converter to provide a low DC signal that is proportional to the high DC level of the main batteries (Appendix I). The other two are FDT 350 frequency-to-voltage converters to provide low DC signals that are proportional to the vehicle speed of the bus and the engine speed of the APU. Also within this same enclosure is a small solid state DC to DC converter to provide bipolar $+/- 15$ V power to the current sensors. Power and signals enter and exit this enclosure via a single cable whose individual conductors terminate at or near the screw terminals adjacent to the Data Logger. The three modules and the DC to DC converter all receive power from the negative terminal of the auxiliary power 12 V battery and the 12 V switched input to the auxiliary power 12 V converter.

5.3 Sensors

Current sensors are located both above and below the main fuse block, inside the bus, on the left (Figure 5). Battery voltage is taken directly from two of the main fuse block terminals. Vehicle speed and engine speed are taken from screw terminals located at the top and rear of the APU. Brake and accelerator pedal signals are taken from OEM potentiometers already on the bus that send signals to the motor controller. A schematic is shown in Figure 6. A description of the control pedal transducer's functions, supplied by the manufacturer, is shown in Appendix G. These signal wires run down the left center of the bus. Thermocouples are located in the left rear air duct scoop, under the handicapped seat, and in each of the four battery banks.

Legend:

 = current sensor orientation

wire colors indicate color of current sensor leads

 = positive current

 = negative current

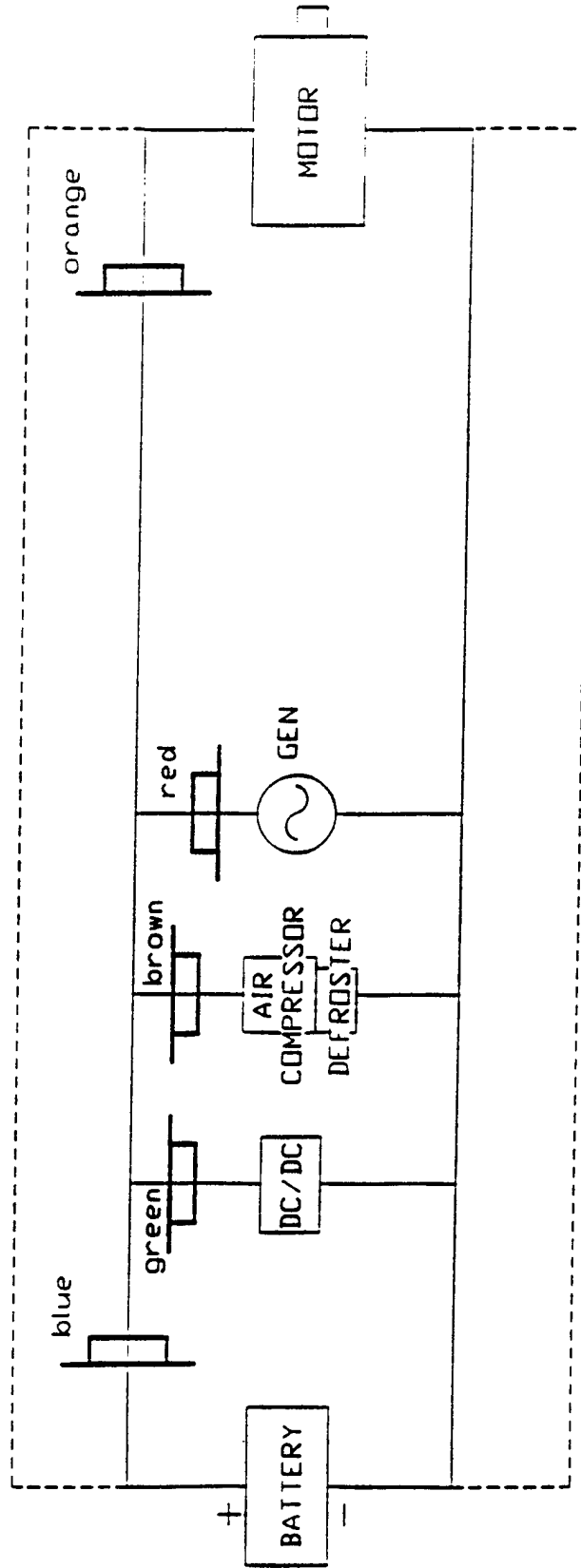

Figure 5. Current sensor placement and orientation

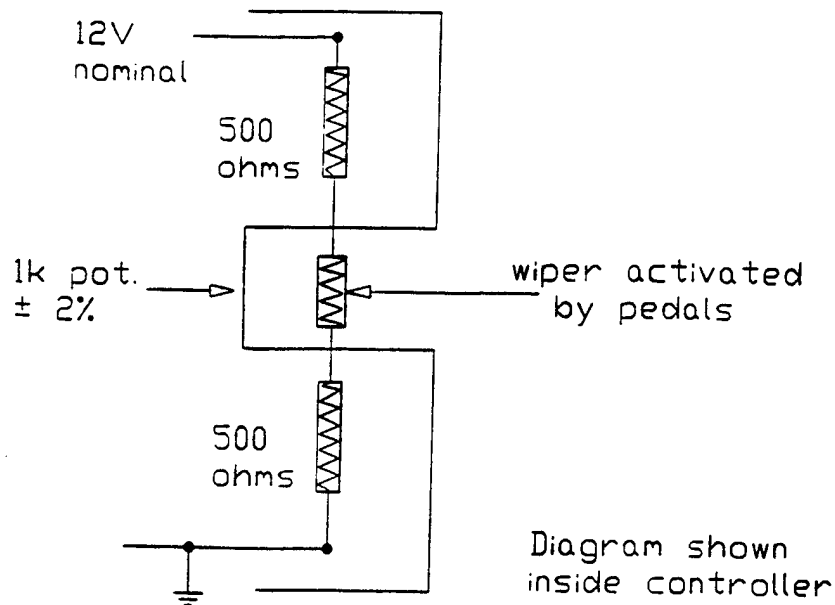

Figure 6. Brake and accelerator pedal position

6.0 OBSERVATIONAL DATA

Due to problems with the data logger and the unavailability of AVS personnel to assist SwRI with debugging the data logger, collecting operational data was abandoned. However, AVS/CARTA have run the APU while the bus is in service and have reported the following on its operation:

The APU has a tendency to overheat. AVS consulted with Alturdyne regarding the problem and determined that the cooling system must be bled. AVS is adding a second circulating pump as an extra measure.

The current draw of the data logger, the APU, electric lighting, and the cooling fans exceeded the capacity of the DC to DC converters. There is not enough 12 V DC power to run the lights. An additional DC to DC converter was installed to boost current from 60 to 90 amps. This solved the problem.

In cold weather the APU has starting problems. This is a fuel supply problem associated with LPG that was not addressed in the design or installation.

The APU has difficulty maintaining a charge on the battery so the vehicle has a limited driving range. As discussed in Section 3.5, the APU is not set to provide enough power to meet average road load demand and charge the batteries at a reasonable rate. AVS and CARTA have not, however, determined the actual range of the vehicle in hybrid form.

7.0 RECOMMENDATIONS AND CONCLUSIONS

It is not recommended that a following APU be produced for AVS as they do not have the resources to support such a project at this time without more support from DARPA. If AVS is still interested in getting the first unit to perform as hoped, it should work in partnership with Alturdyne to achieve mutually desirable results. The potential for this APU has not been fully realized.

7.1 Control Approach

Although there has not been enough data collected to formulate final opinion, the following recommendations and conclusions represent additional thinking on the subject. The initial control logic was to turn the APU on when the state-of-charge becomes low (e.g. 60 percent). When state-of-charge returned to a high level (85 percent) the APU would be turned off. The APU power is restricted to protect the batteries and the motor controller.

- State-of charge is determined by measuring open circuit voltage of the battery pack. This is the easiest indicator, yet it is notoriously inaccurate. One solution is to base the APU duty cycle on *energy consumption* (i.e., kWhr in and out of the battery pack). The algorithm would have to include decreasing capacity as cycles accumulate on the battery.

- The maximum APU output power was limited to 13.8kW to protect the batteries. A battery controller should be installed as the current limiter, not the engine. The APU should load track the drive motor while the battery controller limits the current into the battery pack.
- A different motor controller or a power-conditioning device between the motor controller and the APU/Battery power supply should be used. Restricting the APU to only 230V is very limiting in terms of the charging rate. As the battery state of charge increases, or battery temperature decreases, so must the battery charging voltage. To drive more current into the batteries, the charger must increase voltage. This voltage is limited by the battery gassing and other harmful effects.
- In the early design stages, it was decided that the APU should idle when approaching a curb, so as not to disturb on-boarding passengers. As later determined, the noise level requirement was very close to what the APU was emitting (Table 2). (The requirement by AVS was that it should "*sound like an electric bus.*") The result is that it is not necessary to idle the engine while the vehicle is stopped. The APU can then put full power into the batteries, provided the current into the batteries was limited and the controller had overvoltage protection.

7.2 Mechanical Components

Due to the tight schedule requirement, several design decisions were made based on availability of components. Again, there is not enough data to determine if there are serious problems, but the following represents additional thinking on the subject:

- A 55 kW, 400 Hz aircraft generator was used. The high operating speed and low power made it necessary to belt drive rather than direct drive this generator. The belt drive could be a major source of vibration. Perhaps the use of a different generator with a lower speed requirement would allow direct drive and reduce noise.

- Relay logic was chosen over a microprocessor due to time constraints. The relay logic circuit does not have the flexibility required to make large changes in the APU control. For example, the upper level cutoff for battery state of charge is limited to 85-90 percent. A microprocessor APU control unit would allow a more complex and flexible control scheme, including a means to budget the APU's energy. Furthermore, a separately packaged control unit may allow for a more flexible installation, and could be remotely mounted.
- Rubber mounts under the APU enclosure would have reduced vibration and noise significantly. Again, the design requirements are still subjective.
- A majority of the noise appears to be coming from the exhaust and from some vibration within the APU unit. More attention given to the muffler system will probably solve the noise problem. Future design efforts should be based on buses that can accommodate an APU unit in the rear section to move the noise away from most passengers.

7.3 Installation

The overheating problem may be attributable to air trapped in the long water lines. The oil and water cooling ports should be relocated to the top of the unit. Running lines up to the existing ports was cramped, difficult to install, and difficult to bleed. A bleed port should also be installed.

The back of the bus is a better location for the APU. It would be more isolated from the passenger compartment and closer to the radiators. This would also reduce the length of exhaust tubing required.

APPENDIX A
ALTURDYNE INFORMATION

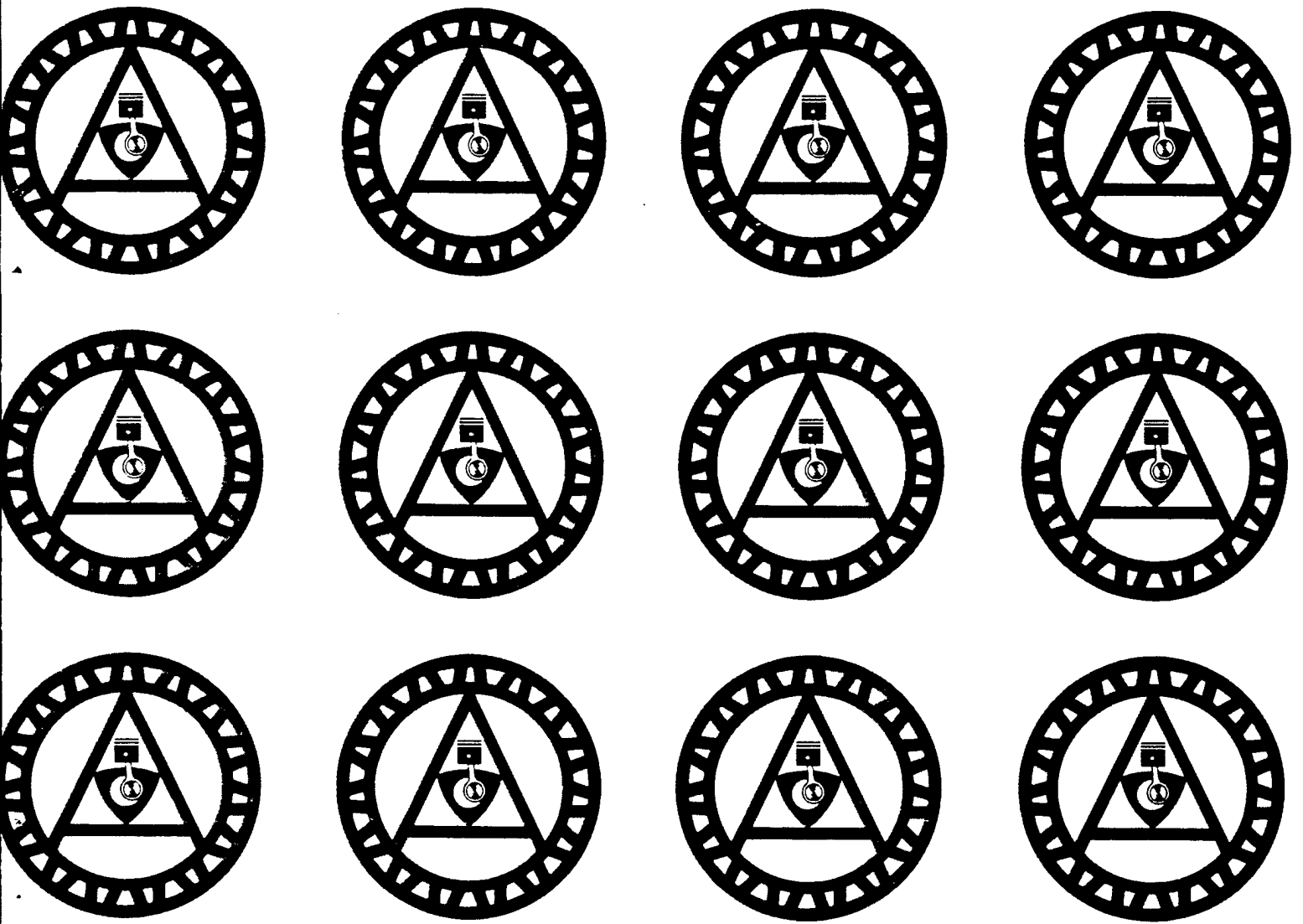

ALTURDYNE

POWER SYSTEMS

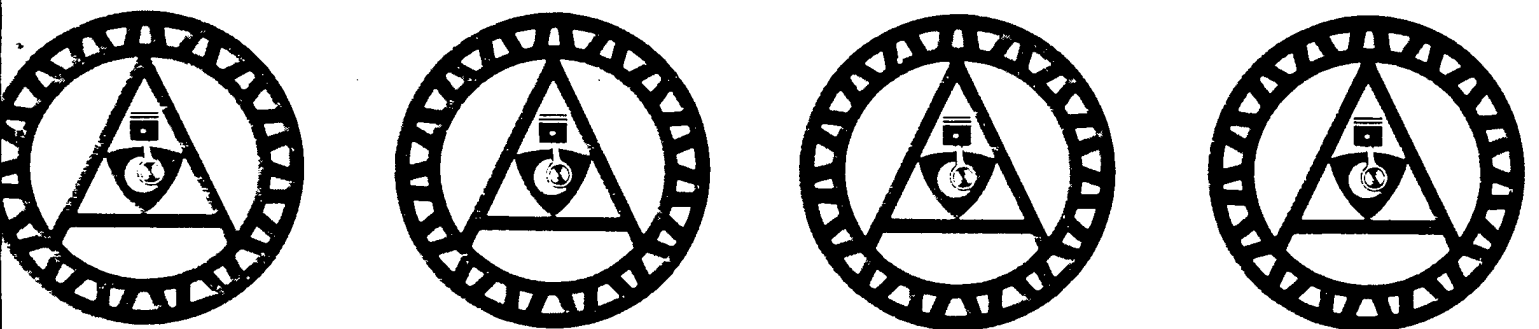

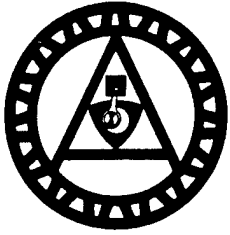

ALTURDYNE

Alturdyne was founded in 1971 to package small gas turbine systems for the commercial and governmental marketplaces. The widespread acceptance of Alturdyne's design, engineering and manufacturing capabilities has resulted in a continuing staff and facility expansion. Presently over 100 people operate two San Diego area facilities and a third in Dallas, Texas.

Alturdyne's Power System expertise extends to reciprocating engine systems, sound attenuation and many related packaging and engineering fields for stationary, portable and airborne applications.

Alturdyne Energy Systems, a subsidiary company of Alturdyne, is active in the development and application of Single and Dual Engine Natural Gas-Driven Chillers.

Alturdyne has acquired many years of experience with custom and specialty engineered systems. This unique ability is available to you in the selection and application of the optimum prime mover for your needs.

Alturdyne has the proven capability to package gas turbine, rotary, and reciprocating engines for a wide variety of applications: Generator Sets, Compressors, Hydraulic Start Systems, High-Speed Reduction Drives, Ground Power Units, and Air-Transportable Power Systems. Selected components of high speed turbomachinery have also been produced.

Alturdyne's professional staff is committed to the advancement of the state-of-the-art in power systems. These technological advancements are readily available to new areas of industry, commerce, and government. A current program is directed at the reduction of engine emissions.

Consulting and A&E services are provided for commercial turnkey installations. Infrared-suppressed, nuclear hardened, and electromagnetic-pulse-suppressed generator sets are an Alturdyne specialty for government agencies. Quality control to MIL-I-45208 is in place and MIL-Q-9858 can be implemented. Certification to ISO9000 and ANSIQ90 are in process.



FRANK VERBEKE
President

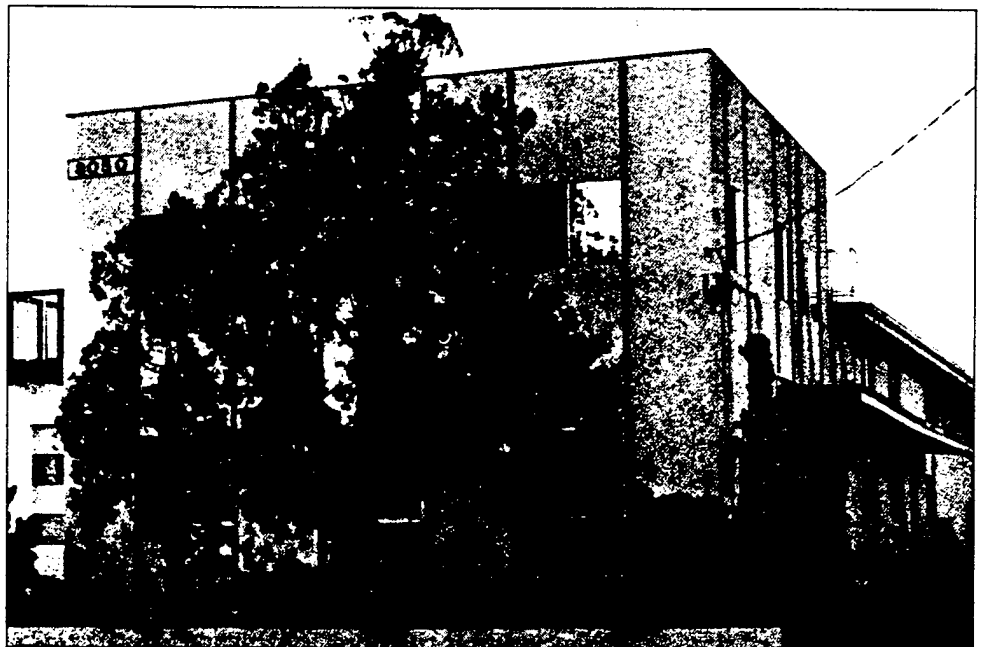

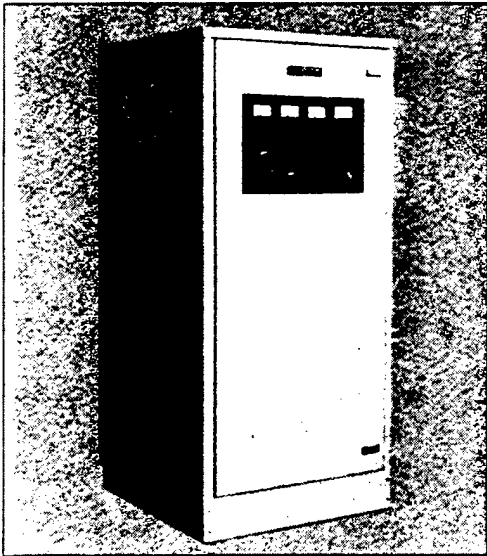

Communications

Alturdyne conventional and vertical gas turbine and diesel engine-powered emergency generator sets are in service worldwide, protecting vital telephone and communications installations. Alturdyne "Verti-Pacs" are unsurpassed where space is at a premium. Vertical 90 and 125 kW gas turbine-powered sets and diesel engine-powered sets from 5 to 125 kW are available. Alturdyne is also a source for horizontal diesel installations to as high as 2000 kW and gas engines.

Government and Industry

Specialized turbine and reciprocating engine systems packages are regularly delivered to a wide variety of customers. Alturdyne gas turbine auxiliary and prime power units, for instance, have been developed to supply multiple outputs from a single prime-mover. Combinations of 400 Hz, 60 Hz, and DC electrical power; hydraulic power; shaft power and compressed air are possible.

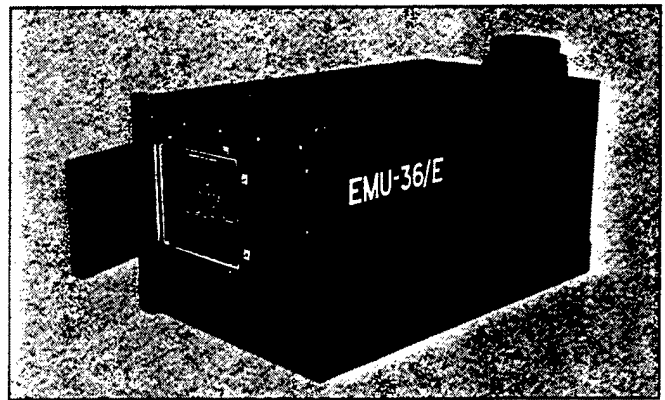

Packaging - Module/Acoustical

Alturdyne provides custom and production packaging to meet the needs of reciprocating, gas turbine, and rotary engine power systems. Our manufacturing extends over a broad range of enclosures, silencers, skids and turnkey modules with power van/trailers to 40' x 10' x 10' to 40,000 pounds. Our experience in applying the appropriate acoustical treatment has contributed to a variety of successful installations. Alturdyne's complete metal working and finishing capability permits custom assemblies to be designed and constructed quickly and economically.

Alturdyne Energy Systems

Single and Dual Engine natural gas fueled chillers for space conditioning, refrigeration and process applications are available in sizes ranging from 30 tons to 300 tons using reciprocating compressors. Larger units up to 3000 tons are available with screw compressors. Units are furnished as a single, self-contained package with engine, compressors, evaporators, condensers, refrigeration specialties and controls.

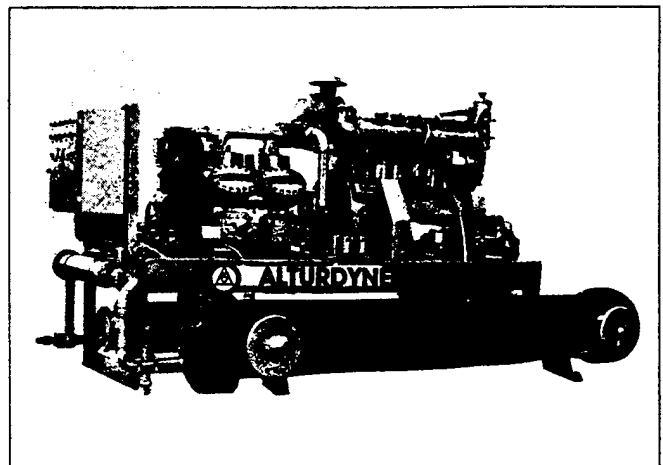

Transportation

MARINE - Alturdyne units supply ship's service and emergency power on high performance ferries, hydrofoil and research vessels.

VEHICULAR - APU's for tracked vehicles and battery charging units for electrical vehicles.

AVIATION - Pod-mounted auxiliary power units for special aircraft applications, ground power carts for aircraft service and support. FAA approved.

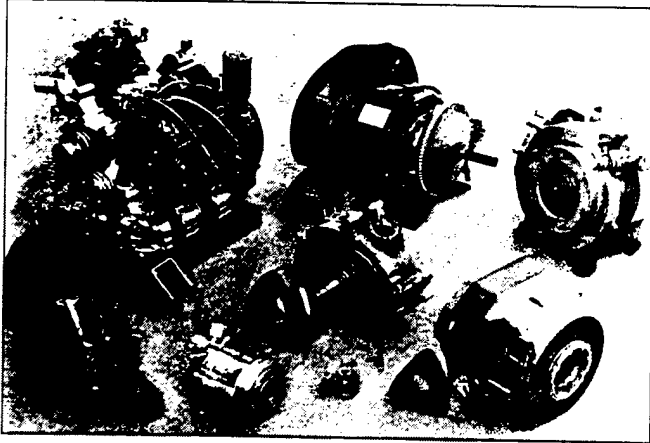
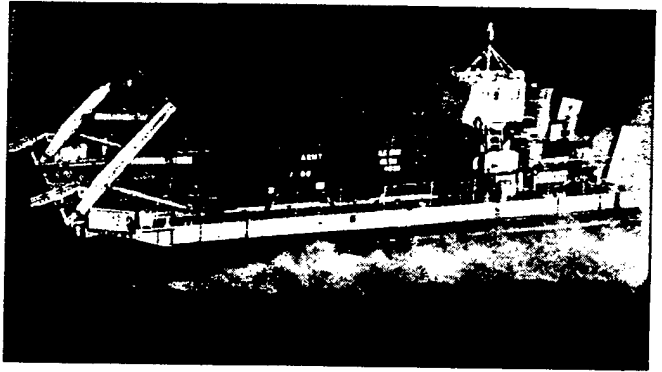

Rotary Engines

Lightweight rotary engines up to 350 HP and utilizing a variety of fuels are under development for industrial, commercial, and government applications. The rotary engine can provide size and weight advantages over turbine engines in pump, compressor, and generator applications.

Research and Development

Alturdyne's research and development activities are centered around advancements in prime mover applications. High-speed reduction gear-boxes, direct-driven turbine load compressors, prototype hardware for electric vehicles and other energy research projects are some of the programs in which we are engaged. Military programs include preparation of DOD-D-1000 and D)D-STD-100 drawings, and completion of other DOD data requirements.

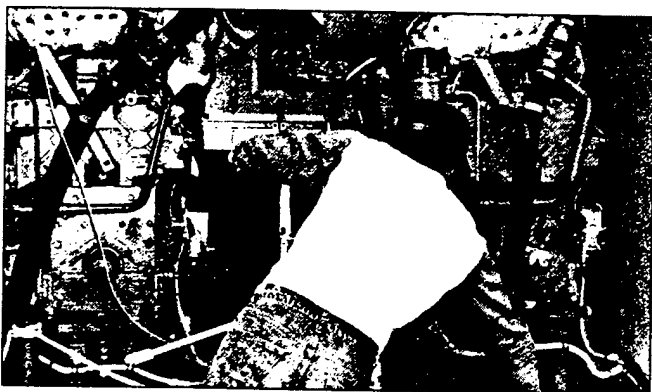
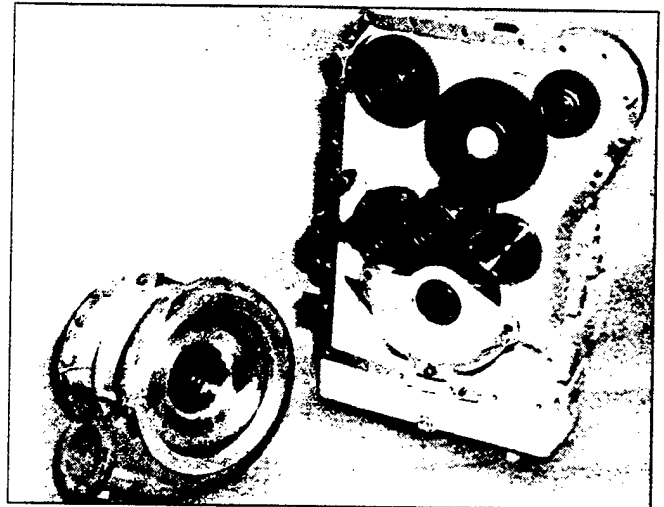

Product Support

Alturdyne's product support team is a full-service organization providing installation consultation and contracting, emergency repairs, preventive and corrective maintenance, spare parts, publications, and equipment modification and modernization. Additionally, Alturdyne offers complete service and parts support for Solar 200 and 225 kW gas turbine generator sets.

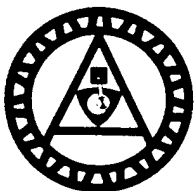

For additional information, write or call:

ALTURDYNE
8050 ARMOUR STREET
SAN DIEGO, CA 92111
(619) 565-2131 • FAX (619) 279-4296
TWX #910-335-2000 • ALTURDYNE SDG

BRANCH OFFICES:

Connecticut, Orlando, Houston, Los Angeles,
San Francisco, Michigan, Washington DC,
Chicago, Dallas, Cleveland, Massachusetts,
Denver, Atlanta, Arkansas and Kansas City.



ALTURDYNE

ENGINE DRIVEN CHILLERS

ALTURDYNE ENERGY SYSTEMS

Alturdyne Energy Systems specializes in standard and custom packaging of natural gas and diesel-fueled Engine Driven Chillers (EDCs). Depending on the area of the country, EDCs can reduce operating costs from 30 to 70 percent when installed in place of electrically driven HVAC units. Computer analyses for both load and economic payback are available. A variety of refrigerants is offered to suit specific customer needs, including R-22, R-717, and R-134A. Designs range from efficient air cooled condensing/direct expansion evaporation systems all the way up to extremely efficient water cooled condensing/chilled water evaporation systems. Low temperature custom units can be provided to suit the needs of

process industries. Alturdyne produces EDCs with capacities from 30 to 1,100 tons, with compressors, depending on the application, being available in either reciprocating piston type or continuous screw type. All engines are rugged, long-life industrial units and can be configured to run on alternate fuels. The natural gas-fueled line is certified by **Environmental Test Laboratory (ETL)** to meet AGA 4-89. Alturdyne will soon offer an entire family of chillers driven by natural gas-fueled industrial rotary engines. Sound attenuated, all weather enclosures can be fabricated to the customer's specifications.

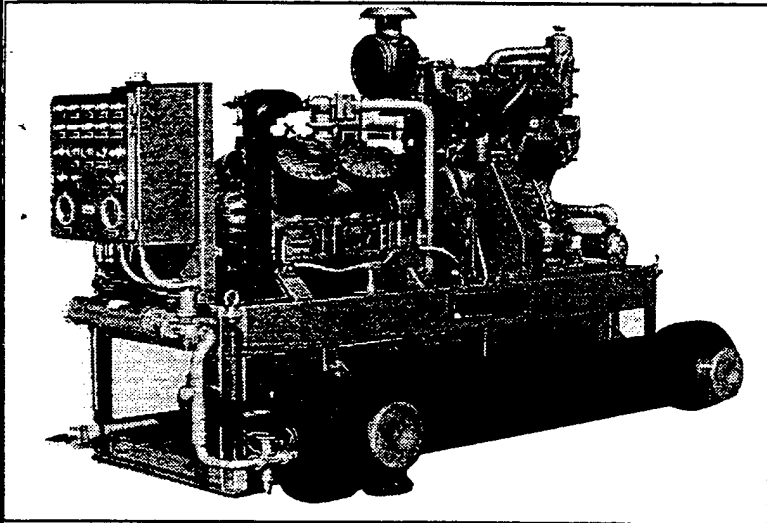

30 TO 150 TONS:

Single Engine,
Reciprocating Compressor,
Water-Water Cycle

Alturdyne Energy Systems offers six models of EDCs powered by a single engine driving a reciprocating piston compressor. These units feature the extremely efficient water cooled condensing/chilled water evaporation cycle. Their shell and tube heat exchangers are readily accessible for maintenance purposes. These models are approved by the **Environmental Test Laboratory (ETL)** and are so listed.

200 TO 300 TONS:

Dual Engine,
Reciprocating Compressors,
Water-Water Cycle

These high capacity installations feature two engines, each driving a separate compressor to provide greater overall output with no sacrifice in efficiency. High efficiency is achieved by using an alternator control panel with automatic lead-lag capability. The panel monitors the building load and brings the second engine compressor unit on-line only as needed. Once on line, the panel shares the load between both units to ensure maximum engine life. The panel may be programmed to alternate the designated lead engine to prolong the lives of the engines or, depending on customer's maintenance needs, may be set to permanently designate a specific engine as the lead. These models are also ETL approved and listed.

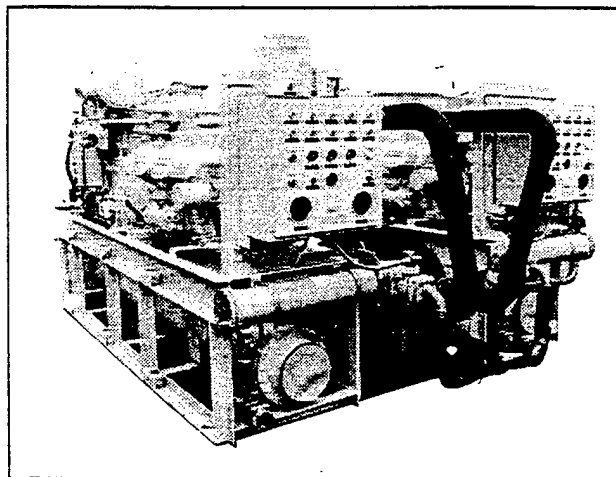

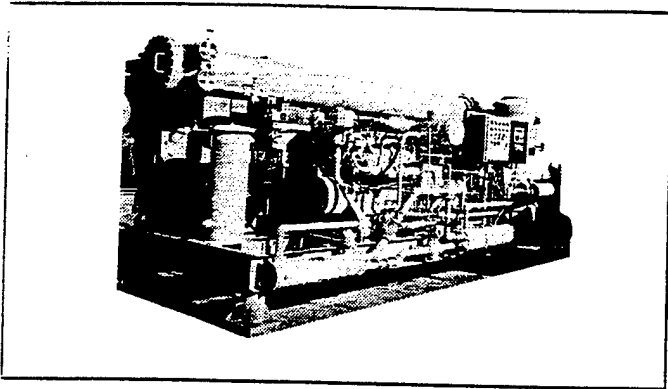

350 TO 1,100 TONS:
 Single Engine,
 Screw Compressor,
 Water-Water Cycle

Alturdyne's line of single engine driven screw compressors is designed to meet the needs of customers with larger tonnage requirements. The positive displacement nature of screw compressors makes them continuously efficient over a wide range of speed. Additionally, the ability of screw compressors to use a multitude of refrigerants allows them to be tailored to the customer's environmental concerns.

30 TO 100 TONS:
 Single Engine,
 Reciprocating Compressor,
 Air-Water Cycle

In the event the customer does not have a cooling tower, Alturdyne can provide five different models of these air cooled condensing/chilled water evaporation systems. A remote engine radiator is required in these installations. Evaporative condensing is also available on these units as an alternative to air cooled condensing. These models are also ETL listed.

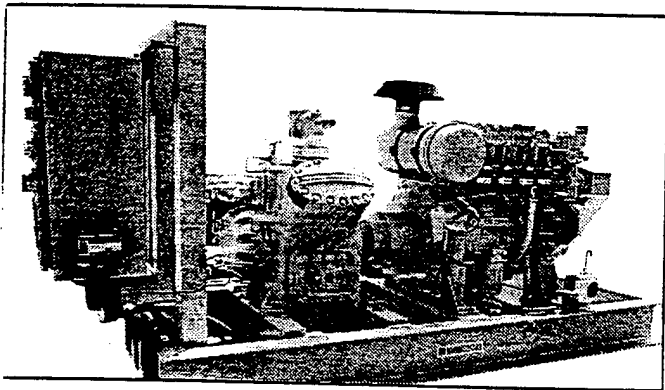
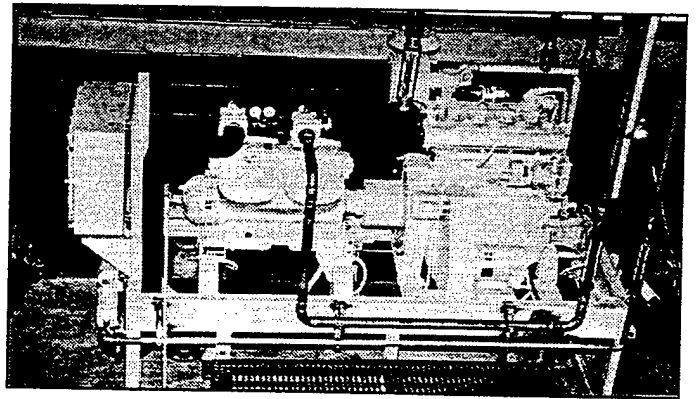

30 TO 145 TONS:
 Single Engine,
 Reciprocating Compressor,
 Air-Air Cycle

These air cooled condensing/direct expansion evaporation units are used when a cooling tower is not available and the customer elects to use the refrigerant to directly cool the building load. A remote engine radiator is also required with the six different models offered in this line. Evaporative condensing is also available with these systems. These models are ETL listed.

ENCLOSURES AND CONTROLS

Alturdyne provides custom indoor/outdoor enclosures in both walk-around and walk-in styles fabricated of marine aluminum or heavy gauge steel to provide excellent weather, animal and vandal protection and/or sound attenuation. Enclosures may be mounted directly to a concrete slab or onto the chiller package skid base.

Alturdyne offers inexpensive, programmable, weather resistant control systems designed to meet the unique requirements of each application. Using proven, rugged, electro-mechanical components or microprocessors, these controls have shown themselves to be long-lasting, reliable and easy to maintain. Custom controls modifications are available.

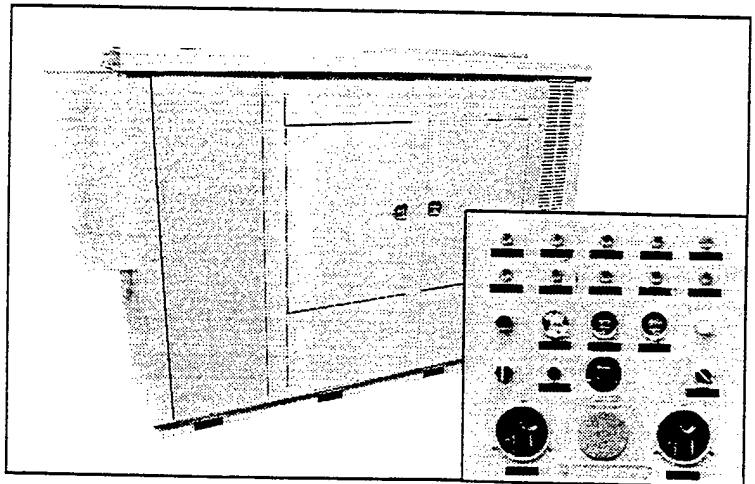

ALTURDYNE

Home Office:
 8050 Armour Street
 San Diego, CA 92111
 (619) 565-2131
 FAX (619) 279-4296

Branch Offices:
 Connecticut, Orlando, Houston,
 Los Angeles, San Francisco, Michigan
 Washington DC, Chicago, Dallas,
 Cleveland, New Jersey, Denver,
 Atlanta, Arkansas, and Kansas City

ALTURDYNE

GOVERNMENT AND MILITARY POWER SYSTEMS

ALTURDYNE

Alturdyne specializes in custom and production packaging of gas turbine, rotary and reciprocating engines for the military for a wide variety of applications. These applications include Quiet/Reliable Generator Sets, Compressors, Hydraulic Start Systems, High-Speed Reduction Drives, Air-Bleed Systems, Fluid Pumps, Fan Drives, Mechanical Drives, Ground Power Units and Air-Transportable Power Systems. Alturdyne's experience and expertise extend to sound attenuation, achieving multiple outputs from a single prime mover and infrared-suppressed, nuclear-hardened, electromagnetic-pulse-suppressed generator sets.

Alturdyne is committed to the advancement of state-of-the-art power systems packaging and application and to making this technology work for the military and the government.

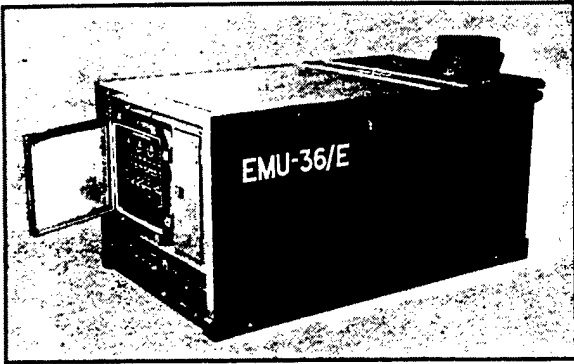

EMU-36/E

The EMU-36/E is a 60 kW, 400 Hz generator developed as a high reliability and maintainable set for the U.S. Air Force's Ground Launch Cruise Missile System. These units feature a weatherproof/ground launched enclosure, multi-fuel capability, multiple outputs, nuclear hardening, infrared suppression, remote operation, precise power, bite-analog diagnostics and a simplified control panel. In addition, they are parallelable, lightweight, compact (60" x 35.25" x 29.5"H), and may be air-lifted and operated in extreme environmental conditions.

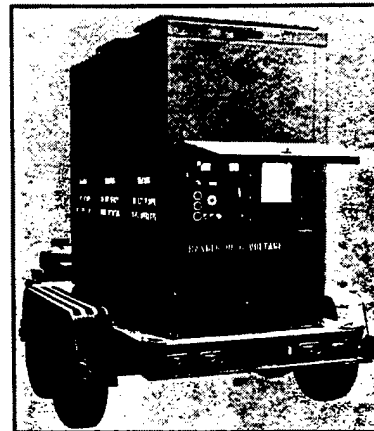

QUIET/RELIABLE ARMY TRAILER

Quiet generator sets are a specialty at Alturdyne. This is one of nine quiet, trailer-mounted, diesel engine generator sets purchased by the U.S. Army for evaluation of commercial-type mobile power systems. These sets were produced in 60 kW models using a turbocharged, six-cylinder, in-line diesel engine and 125 kW models using a turbocharged, V-8 diesel engine. Noise level performance for these sets demonstrated a remarkable 65 dBA at 25 feet. These units are fully self-contained and incorporate a 100-gallon fuel tank mounted in the trailer.



LACV-30

The LACV-30 (Lighter, Amphibian, Air Cushion Vehicle—30 ton payload) is a fully amphibious, high-speed cargo carrier developed for the U.S. Army. It is primarily used to move cargo from ship to shore and inland when port facilities are not available.

Alturdyne designed and built, under contract to Bell Aerospace Textron, gas turbine auxiliary power units used on this craft. The gas turbine engines used in the auxiliary power units are coupled to an Alturdyne dual-output reduction gearbox. One output rotates at 3600 rpm supplying 85 hp to a shaft-driven fan for the Air Management Filtration System. This system provides forced air through the filter system to feed the main turbine powerplants fresh intake air. The other output rotates at 6000 rpm and supplies 45 hp to drive a 400 Hz generator.

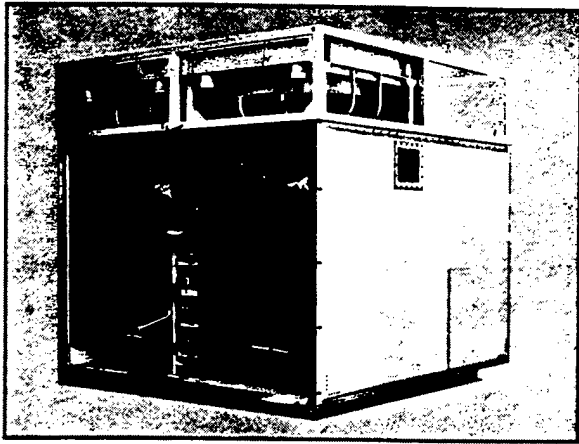

DIESEL PGU

This unit is a sound attenuated, nuclear hardened, continuous duty power generation system used by the U.S. Air Force for communications and strategic surveillance purposes. These self-contained units are rated at 125 kW and can be operated continuously for 2000 hour intervals utilizing an automatic oil feed system. They are powered by twin Detroit Diesel 4-71T turbo-charged diesel engines which operate independently of each other. For fast maintenance and overhaul, all systems have quick-disconnect components to provide minimum down time.

JASU (JET AIRCRAFT START UNIT)

JASU is a gas turbine/load compressor used for main engine starting on jet aircraft. It was designed and packaged by Alturdyne under contract to Turbomach for the U.S. Navy.

To keep production costs to a minimum and provide maximum reliability, 90 percent of the components used are current "off the shelf" production items which have been proven in similar applications in the past. It is powered by a gas turbine capable of over 300 horsepower, and produces 150 ppm of airflow at a delivery pressure of 60 psig at sea level, 60°F.

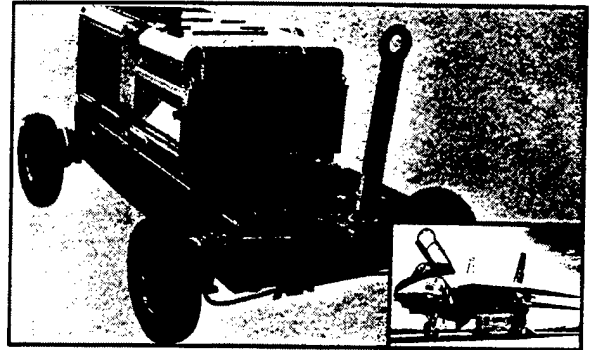

MEP-409A/750 kW AIR-TRANSPORTABLE TRAILER

Alturdyne subcontracted to design and package these semi-trailer mounted 750 kW air-transportable gas turbine generator sets for the U.S. Army. These units are special low-profile, self-contained sets that have a unique cargo handling system, enabling loading and unloading on C-130 aircraft without special ground support equipment in less than four hours by as few as two men. This can be done quickly in remote areas that may not have machinery for hauling and lifting.

The generator sets provide 4160 volts at 60 Hz or 3460 volts at 50 Hz operation. The highway-legal trailers (40' long and 8' wide) contain all equipment necessary to provide electrical power as soon as cables are connected to the output panel. A soundproof room is located at the rear of the trailer for the operator and contains the control console, power switch-gear, station power transformer, telephone jack, desk, lights and ventilation. The unit also comes with a remote desk-top control panel for operating two or more units from a central remote control station. A 500-gallon day tank provides enough fuel to operate the set for up to seven hours.



FAA TRAILERS

These self-contained 60 kW, 60 Hz gas turbine generator systems were manufactured for the Federal Aviation Administration to provide emergency power at FAA facilities during maintenance and repair of stationary engines. The trailers include integral fuel tanks, voltage selection and on-board automatic transfer switches.



ALTURDYNE

Home Office:

8050 Armour Street
San Diego, CA 92111
(619) 565-2131
TWX 910-335-2000
FAX 619-279-4296

Branch Offices:

Connecticut, Orlando, Houston,
Los Angeles, Oakland, Michigan,
Washington DC, Chicago, Dallas,
Cleveland, New Jersey, Denver,
Atlanta, Arkansas and Kansas City.

ALTURDYNE

RECIPROCATING ENGINE POWER SYSTEMS

ALTURDYNE

Not all power systems are created equal ... nor are the requirements for each application. That's why Alturdyne designs and installs hundreds of power systems each year for some of the most discriminating customers.

Alturdyne is a full service supplier for a wide range of products and applications, including a complete line of economical and reliable reciprocating engine-driven power systems in sizes to 1250 kilowatts. Applications that call for specialized engineering, manufacturing, or testing are an Alturdyne forte. Alturdyne has the unique capability and experience to provide emergency and prime power system packaging using reciprocating, rotary, and gas

turbine prime movers. Fuels utilized include diesel, gasoline, natural gas, and LPG. Engines may be liquid or air cooled; with or without heat recovery; and packages with 50, 60, and 400 Hz outputs have been furnished.

Alturdyne's expertise extends into the areas of sound attenuation, multiple-outputs from a single prime mover, and the application of stringent military specifications and requirements.

The reciprocating engine products shown here reflect over 15 years of research, development, and experience which have made Alturdyne a leader in state-of-the-art power system packaging.

Open Power Systems

Alturdyne offers a wide selection of systems from small emergency generators to complex multiple-unit systems. Alturdyne has designed, tested, and installed equipment using engines and generators of virtually all of the major manufacturers and can guarantee the best selection for the job. Options and accessories are integrated by our engineers to meet all requirements, and custom control systems are designed to provide the utmost in performance and troublefree service.

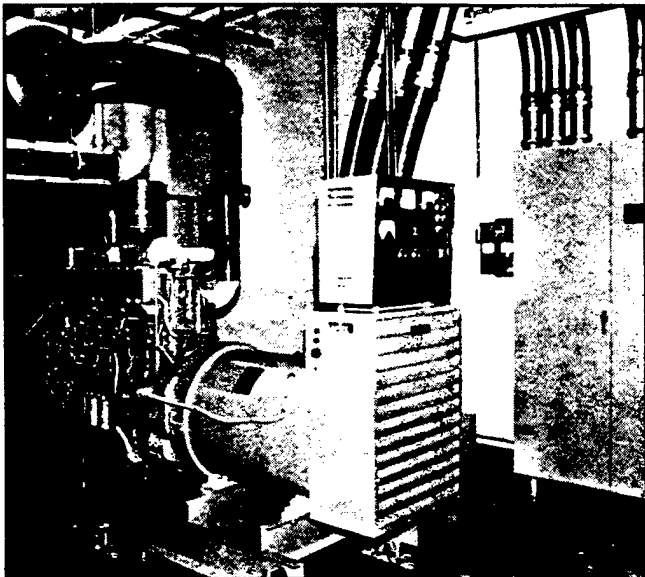

Enclosed Power Systems

Alturdyne's standard enclosure systems are specifically engineered for our full line of open power systems to 1250 kilowatts. Accessories to complement any of our enclosed power systems include sound attenuation packages consisting of silencer systems and acoustic enclosure treatments, base fuel tanks that add convenience and minimize installation expenses, heating systems with motorized louvers for cold weather applications, and a vast array of automatic transfer and remote control/status options.

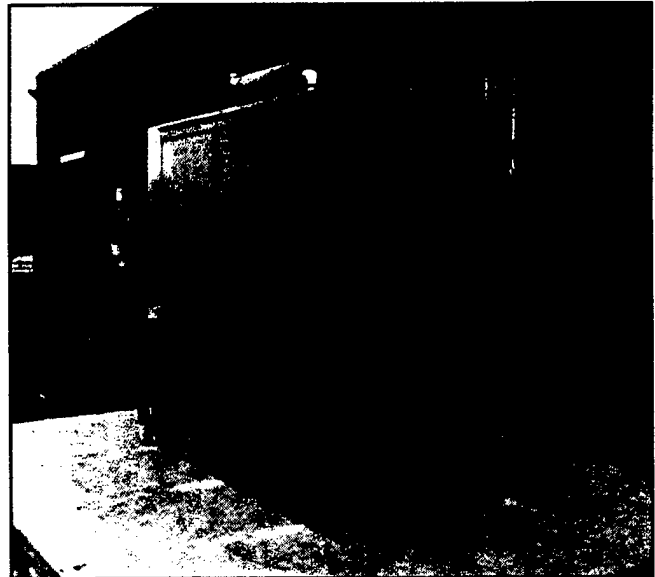



SPECIALIZED POWER SYSTEMS

Design and packaging of one-of-a-kind and specialized systems accounts for much of Alturdyne's work. Hundreds

of unique power systems and related products have been developed for government, military, and commercial applications. Experienced design engineers are assigned directly to jobs and project engineers are responsible for each system through completion.

Diesel Hydraulic Starter System

Alturdyne's diesel engine-driven hydraulic starter system replaces the jet fuel starter on Allison 2500 kilowatt gas turbine powered generator sets, and is also adaptable for Solar Centaur and Kongsberg Viking generator sets. Alturdyne's starter system is a cost-effective alternative to the hard-to-support jet fuel starter utilized in many existing installations.

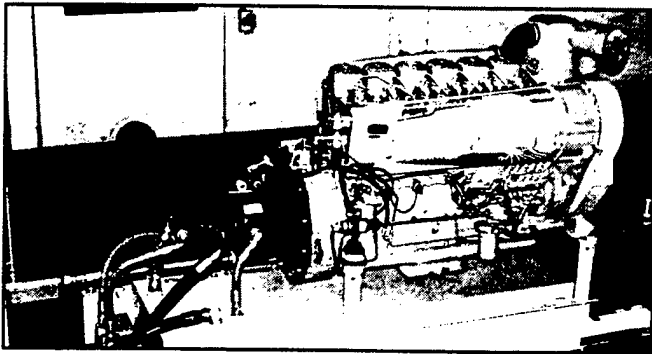

General Purpose Outdoor Engine Generators

These unique 10 to 20 kilowatt general purpose outdoor engine generator systems were developed to support remote fiber optic communications systems and CEV's (Controlled Environment Vaults). The weatherproof heavy gauge steel enclosure is virtually vandal-proof. Fuel tank subbases are available to suit customer requirements. Low profile design and acoustic enclosure treatments ensure a system that will not disturb the surrounding community.

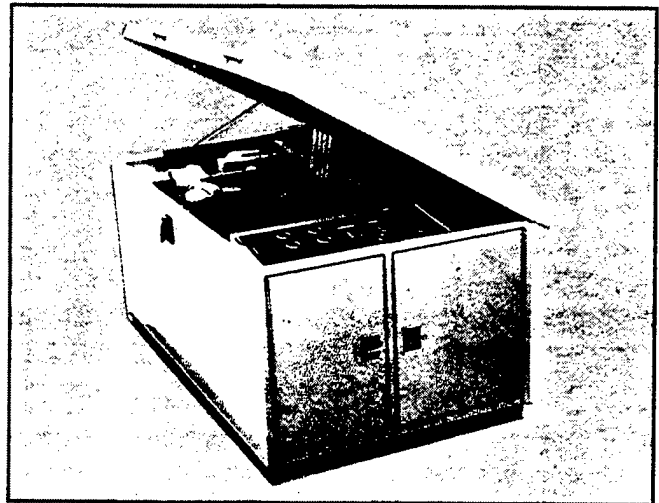

5 kW To 125 kW Vertical Diesel Engine Emergency Generator Sets

Alturdyne's "Verti-Pac" vertical diesel engine emergency generator sets were initially developed for the telecommunications industry's emergency power needs. These units established new standards for size, weight, sound level, performance, and ease of installation. The engine, generator, radiator, controls, battery and battery charger, and muffler are housed within a sound attenuating enclosure. These packages are ideally suited for applications where space is at a premium and do not require a separate engine room. Two openings in the wall for air intake and exhaust are the only building modifications normally required so no thermal loads are placed on the building's HVAC system.

Gas Fueled CEV Generators

Alturdyne offers environmentally responsive propane and natural gas fueled CEV generators. The units are packaged in aluminum, acoustic, weather-resistant housings that include vandal-proofing features as well as bird and rodent protection measures. For greater versatility, Alturdyne offers these gas-fueled units with both liquid and air cooled engines.

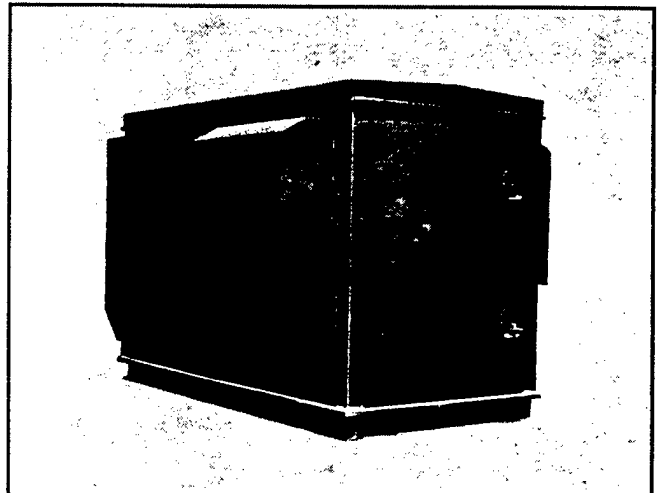
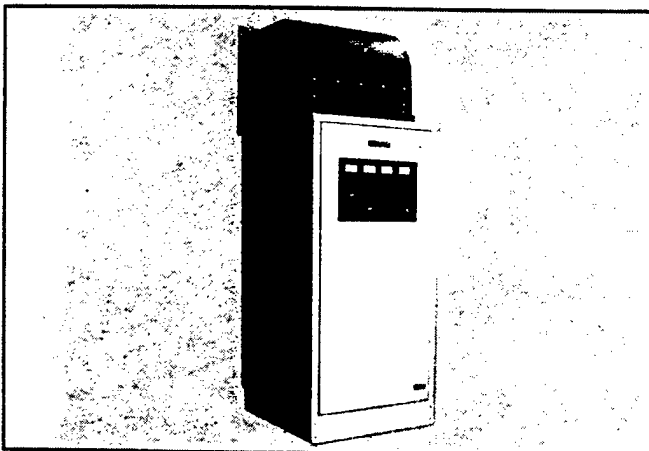

Motion Picture and Television Lighting Generator Sets

The motion picture industry demands precise voltage and frequency regulation and extremely low noise levels for flicker-free lighting and sensitive audio requirements. Alturdyne was an industry pioneer in the development of diesel engine powered generator sets for the motion picture industry with outputs to 1200 amps DC. Virtually any combination of AC and DC outputs—switchable or concurrent, single or three-phase, are available. Noise level performance of these sets is a remarkable 65 dBA or better at 25 feet. Smaller sets have been produced for the television industry.



Trailer-Mounted Systems

Many of Alturdyne's products can be mounted on our heavy duty trailers, or Alturdyne can design a system to your specifications. Single-axle, tandem-axle, and semi-trailers to 40,000 pounds have been manufactured. In addition to many standard features, options can include integral fuel tanks, on-board automatic transfer switches, cable reels, auxiliary lighting, and custom control systems. Alturdyne has manufactured transportable systems to 3000 kilowatts in highway legal semi-trailers that included soundproof control rooms filled with controls, switchgear, and paralleling equipment.

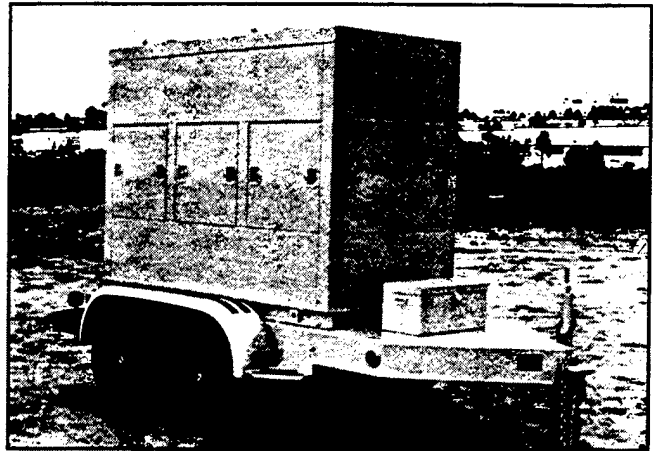

Walk-In Module Systems

Complete sheetmetal fabrication capabilities allow Alturdyne to supply modules in many sizes and for many applications. These packages are designed and delivered as an integrated installation system that incorporates a skidmounted engine-generator set and all supporting equipment. Each package is installed, tested, and comes complete with air inlet, exhaust, fuel, heating, lighting, and ventilation systems. Alturdyne's standard modules are weatherproof, sound attenuated, transportable, expandable, inexpensive to install, and can be easily moved and reinstalled. Various designs for arctic, tropical, offshore, hazardous, and desert conditions are available. Removable base fuel tanks greatly simplify installation and maintenance expense.

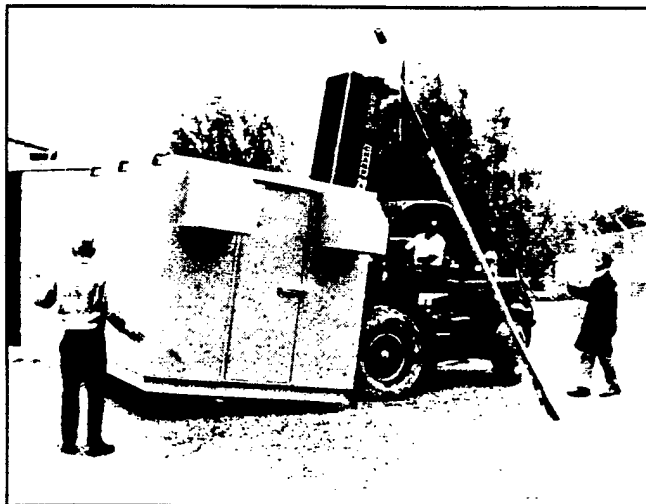

Installation and Service

Alturdyne is based in San Diego, California, and has sales/service offices across the United States. Alturdyne's consulting and commissioning services include the architectural, mechanical, electrical, and acoustical disciplines with special emphasis on electromechanical machinery application. Alturdyne field service representatives are experienced in the installation, repair, and maintenance of all types of power generation equipment. Service associates compliment Alturdyne personnel in providing service coverage for remote locations. Other services include the removal of existing equipment, overhaul services, component or system modifications, and maintenance contracts designed to suit any requirement.

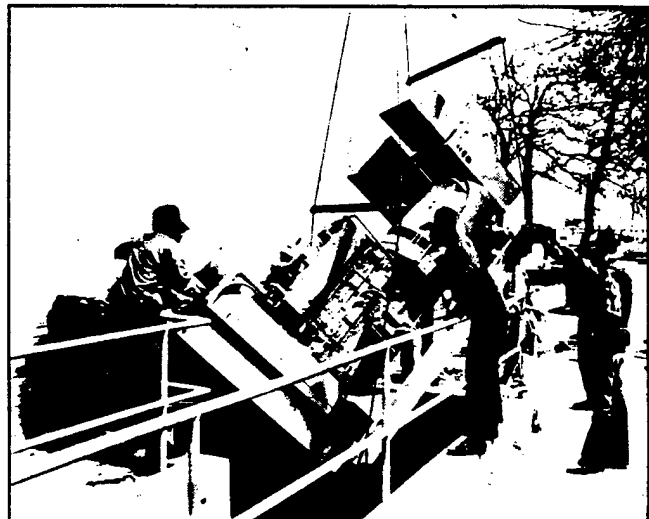



CUSTOM CONTROLS AND ACCESSORIES

Alturdyne has extensive experience in the design and development of controls and accessories for a wide range of systems and applications. Our in-house electrical engineers can respond quickly to customer needs.

Control Panels

Control panels are designed to meet the unique requirements of each application. This control panel for our motion picture lighting generator set, for instance, can be set-mounted or remotely located through the use of a plug-in cable.

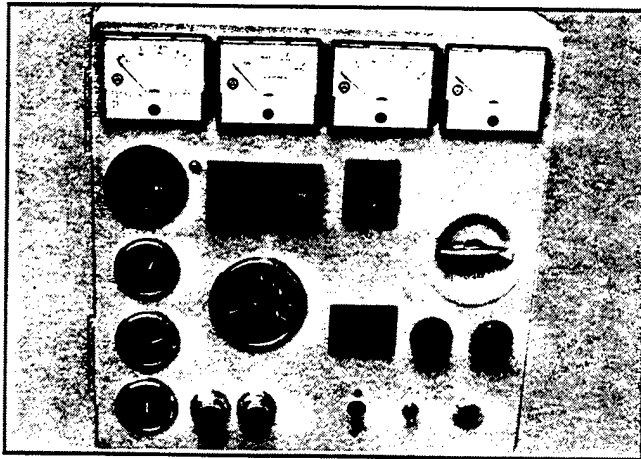

Microprocessor Substitute Controller

This controller was developed by Alturdyne as a substitute for Western Electric's Model J88529 Microprocessor Control for the KS22344 Line of vertical diesel sets. This compact unit meets the form, fit, and function requirements for the sophisticated application, employing commercially available relays and components to simplify field service needs.

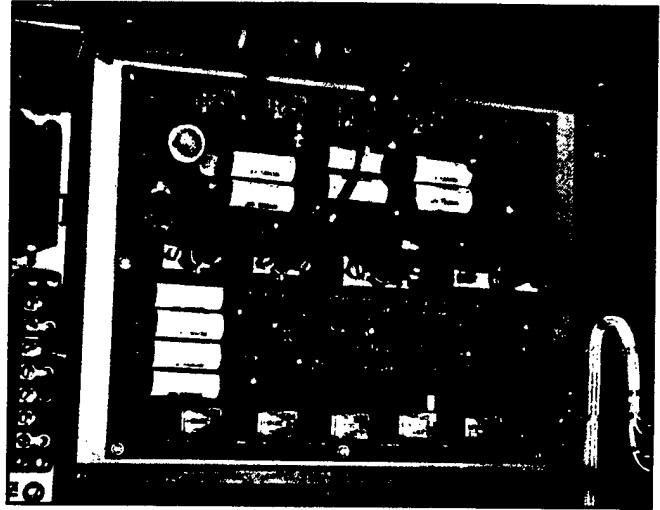

Automatic Synchronizing Systems

Alturdyne has designed a number of automatic synchronizing systems such as the one shown here. Converting existing systems, both reciprocating and turbine, for automatic paralleling can be a cost-effective way of increasing system capacity and reliability. Retrofit of existing equipment with suitable governor systems is frequently a part of the task. Reciprocating and turbine generator sets can be paralleled for maximum use of installed equipment.

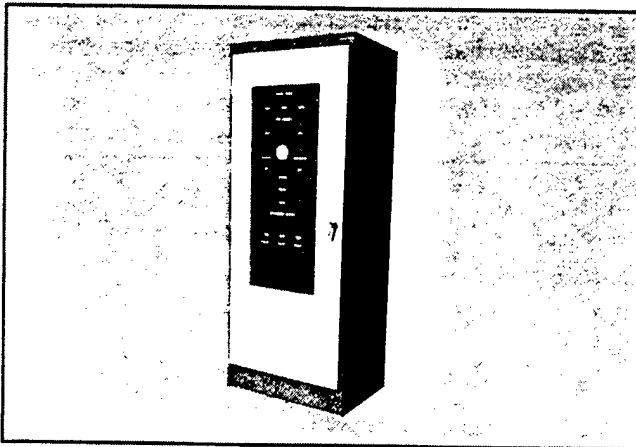

Gas Fueled Chillers

Alturdyne Energy Systems offers engine driven, natural gas fueled chillers for space conditioning, refrigeration, and process applications. Sizes ranging from 30 tons to 300 tons are available using reciprocating compressors. Larger units up to 1000 tons are available with screw compressors.

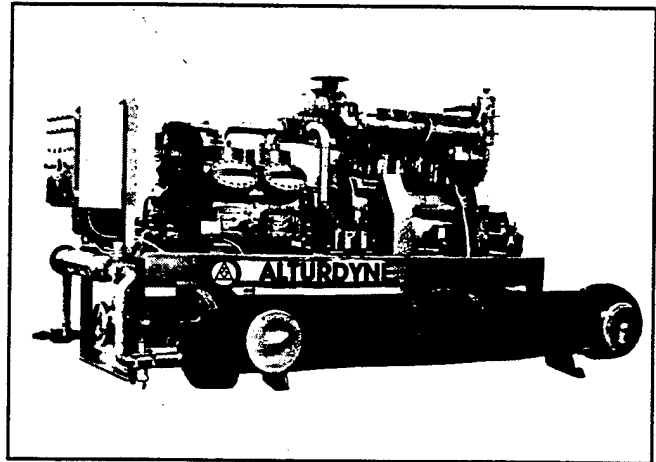

ALTURDYNE

Home Office:
8050 Armour Street
San Diego, CA 92111
(619) 565-2131
TWX 910-335-2000
Fax 619-279-4296

Branch Offices:
Connecticut, Orlando, Houston,
Los Angeles, San Francisco, Michigan,
Washington DC, Chicago, Dallas,
Cleveland, New Jersey, Denver,
Atlanta, Arkansas and Kansas City

1-ROTOR INDUSTRIAL ROTARY ENGINE, NATURAL GAS FUELED, NON TURBO

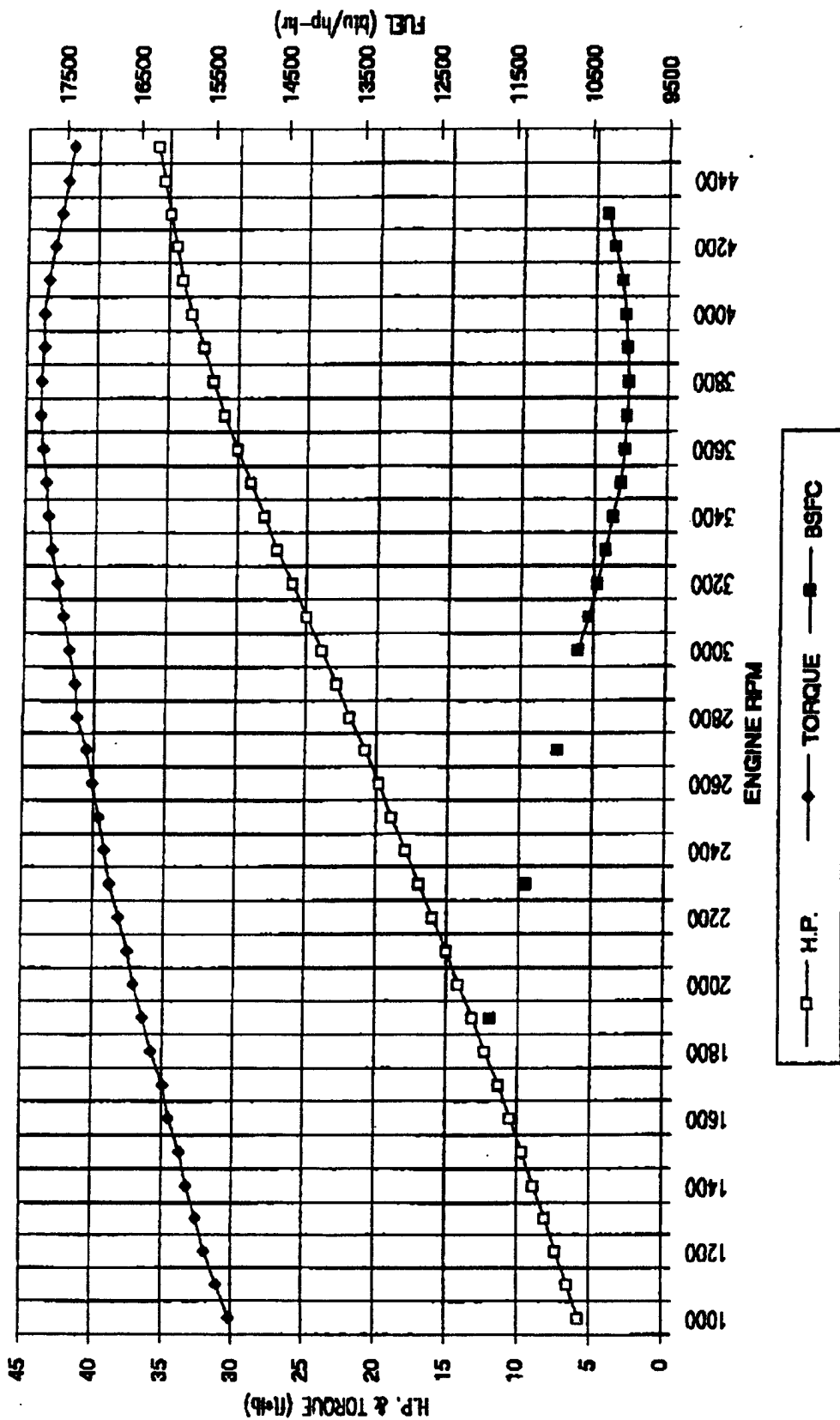

FIGURE A1. HP AND TORQUE, BSFC

EXHAUST EMISSIONS @ W.Q.T. 13B MAZDA / NATURAL GAS

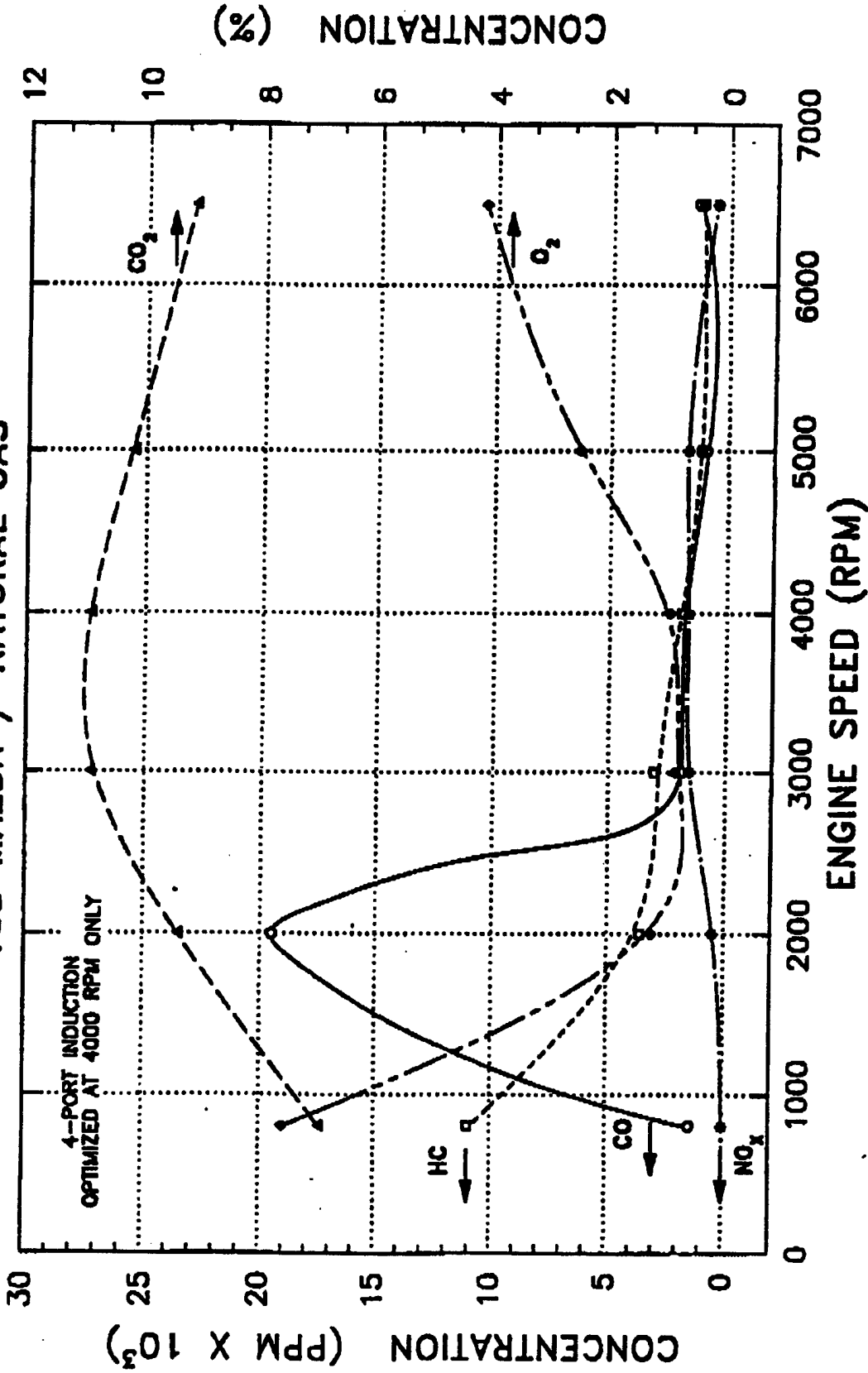

FIGURE A2. EMISSIONS VS. SPEED AT WOT

COOLING LOAD VS. ENGINE RPM AT 100% LOAD

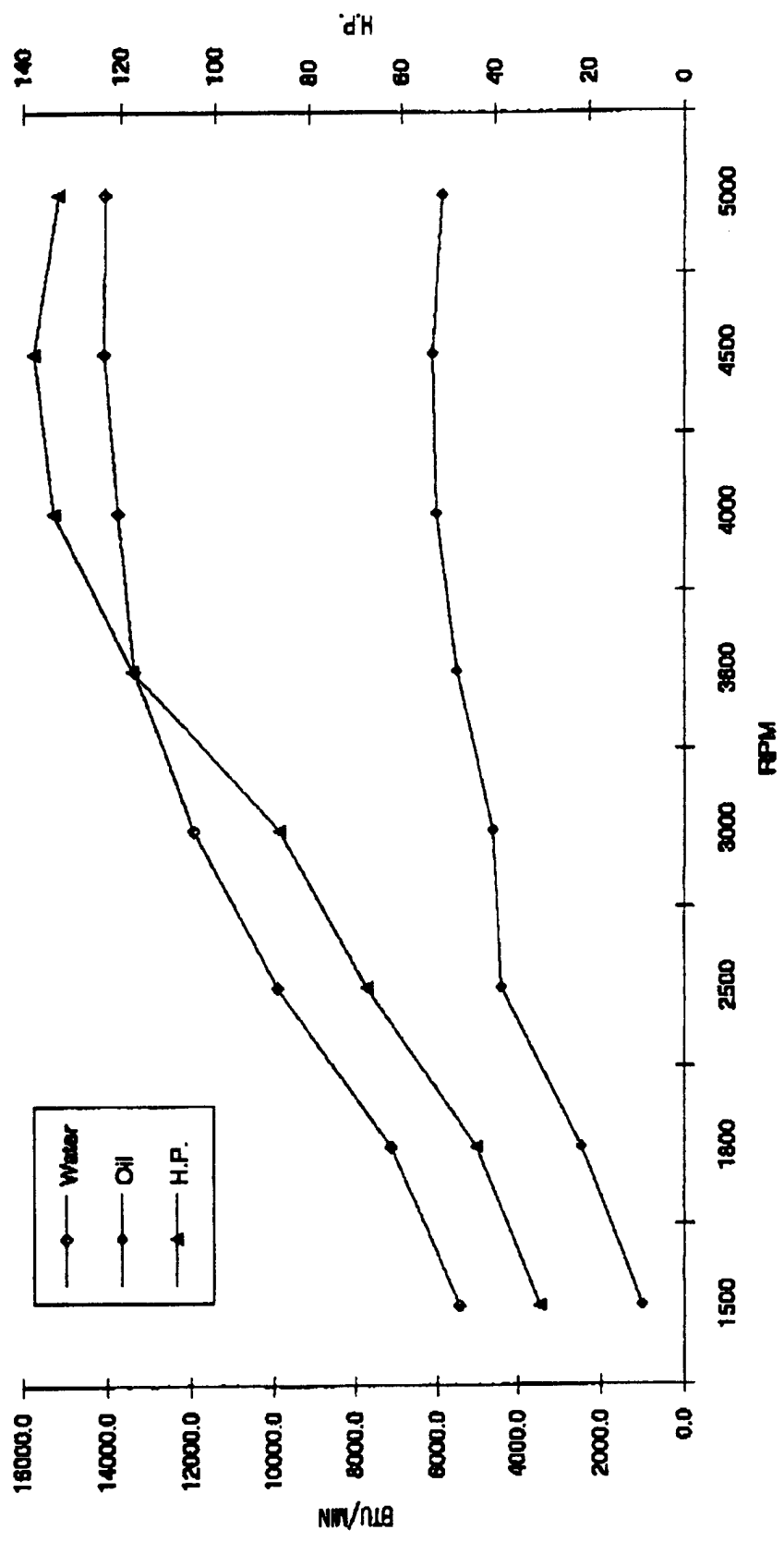

FIGURE A3. COOLING LOAD VS. SPEED AT 100% LOAD

TABLE A1. ENGINE POWER AND TORQUE FOR 1-4 ROTOR UNITS

ALTIUDYNE INDUSTRIAL ROTARY ENGINE

RPM	ROTARY ENGINE, NATURAL GAS FUELED, 640cc/rotor															
	ENGINE POWER (H.P.)				ENGINE TORQUE (ft*lb.)				ENGINE TORQUE (ft*lb.)							
	1-R H.P.	2-R H.P.	3-R H.P.	4-R H.P.	1-R TURBO ft*lb	2-R TURBO ft*lb	3-R TURBO ft*lb	4-R TURBO ft*lb	1-R TURBO ft*lb	2-R TURBO ft*lb	3-R TURBO ft*lb	4-R TURBO ft*lb				
1000	5.7	7.2	11.5	14.4	17.2	21.6	23.0	28.7	30.2	37.7	60.4	75.5	90.6	113.2	120.7	150.9
1100	6.5	8.1	13.0	16.3	19.5	24.4	26.0	32.5	31.0	38.8	62.1	77.6	93.1	116.4	124.2	155.2
1200	7.3	9.1	14.6	18.2	21.9	27.3	29.2	36.5	31.9	39.9	63.8	79.8	95.7	119.7	127.6	159.6
1300	8.1	10.1	16.1	20.1	24.2	30.2	32.2	40.3	32.6	40.7	65.1	81.4	97.7	122.1	130.2	162.8
1400	8.9	11.1	17.7	22.1	26.6	33.2	35.4	44.3	33.2	41.5	66.4	83.0	99.6	124.5	132.8	166.0
1500	9.6	12.0	19.3	24.1	28.9	36.1	38.5	48.2	33.7	42.2	67.4	84.3	101.2	126.5	134.9	168.6
1600	10.5	13.1	21.0	26.3	31.5	39.4	42.0	52.5	34.5	43.1	69.0	86.2	103.5	129.4	138.0	172.5
1700	11.3	14.1	22.6	28.3	33.9	42.4	45.2	56.5	34.9	43.7	69.9	87.3	104.8	131.0	139.7	174.7
1800	12.3	15.3	24.5	30.7	36.8	46.0	49.1	61.3	35.8	44.7	71.6	89.5	107.4	134.2	143.2	179.0
1900	13.2	16.5	26.4	33.0	39.5	49.4	52.7	65.9	36.4	45.5	72.9	91.1	109.3	136.6	145.8	182.2
2000	14.1	17.7	28.2	35.3	42.4	53.0	56.5	70.6	37.1	46.4	74.2	92.7	111.3	139.1	148.3	185.4
2100	15.0	18.7	30.0	37.5	45.0	56.2	60.0	75.0	37.5	46.9	75.0	93.8	112.6	140.7	150.1	187.6
2200	16.0	20.0	32.0	40.0	48.0	59.9	63.9	79.9	38.2	47.7	76.3	95.4	114.5	143.1	152.7	190.8
2300	17.0	21.2	34.0	42.5	51.0	63.7	68.0	85.0	38.8	48.5	77.6	97.0	116.4	145.5	155.2	194.1
2400	17.9	22.4	35.9	44.8	53.8	67.2	71.7	89.7	39.2	49.1	78.5	98.1	117.7	147.2	157.0	196.2
2500	18.9	23.6	37.8	47.2	56.6	70.8	75.5	94.4	39.7	49.6	79.3	99.2	119.0	148.8	158.7	198.4
2600	19.9	24.8	39.7	49.6	59.6	74.4	79.4	99.3	40.1	50.1	80.2	100.3	120.3	150.4	160.4	200.5
2700	20.8	26.0	41.7	52.1	62.5	78.1	83.3	104.2	40.5	50.7	81.1	101.3	121.6	152.0	162.1	202.7
2800	22.0	27.4	43.9	54.9	65.9	82.3	87.8	109.8	41.2	51.5	82.4	103.0	123.5	154.4	164.7	205.9
2900	22.9	28.6	45.7	57.1	68.5	85.7	91.4	114.3	41.4	51.7	82.8	103.5	124.2	155.2	165.6	207.0
3000	23.9	29.9	47.8	59.7	71.7	89.6	95.6	119.5	41.8	52.3	83.7	104.6	125.5	156.9	167.3	209.1
3100	24.9	31.2	49.9	62.4	74.8	93.5	99.8	124.7	42.3	52.8	84.5	105.7	126.8	158.5	169.0	211.3
3200	26.0	32.5	52.0	65.0	78.0	97.5	104.0	130.0	42.7	53.4	85.4	106.7	128.1	160.1	170.8	213.5
3300	27.1	33.9	54.2	67.7	81.3	101.6	108.4	135.5	43.1	53.9	86.2	107.8	129.4	161.7	172.5	215.6
3400	28.1	35.1	56.1	70.1	84.2	105.2	112.2	140.3	43.3	54.2	86.7	108.3	130.0	162.5	173.4	216.7
3500	29.0	36.3	58.0	72.6	87.1	108.8	116.1	145.1	43.6	54.4	87.1	108.9	130.7	163.3	174.2	217.8
3600	30.0	37.5	60.0	75.0	90.0	112.5	120.0	150.0	43.8	54.7	87.5	109.4	131.3	164.1	175.1	218.9
3700	31.0	38.7	62.0	77.5	93.0	116.2	123.9	154.9	44.0	55.0	88.0	110.0	132.0	164.9	175.9	219.9
3800	31.8	39.8	63.6	79.6	95.5	119.3	127.3	159.1	44.0	55.0	88.0	110.0	132.0	164.9	175.9	219.9
3900	32.5	40.6	65.0	81.2	97.5	121.9	130.0	162.5	43.8	54.7	87.5	109.4	131.3	164.1	175.1	218.9
4000	33.3	41.7	66.7	83.3	100.0	125.0	133.3	166.7	43.8	54.7	87.5	109.4	131.3	164.1	175.1	218.9
4100	34.0	42.5	68.0	85.0	102.0	127.5	136.0	170.0	43.6	54.4	87.1	108.9	130.7	163.3	174.2	217.8
4200	34.5	43.1	69.0	86.2	103.4	129.3	137.9	172.4	43.1	53.9	86.2	107.8	129.4	161.7	172.5	215.6
4300	35.0	43.7	69.9	87.4	104.9	131.1	139.8	174.8	42.7	53.4	85.4	106.7	128.1	160.1	170.8	213.5
4400	35.4	44.3	70.8	88.5	106.2	132.8	141.6	177.0	42.3	52.8	84.5	105.7	126.8	158.5	169.0	211.3
4500	35.8	44.8	71.7	89.6	107.5	134.4	143.3	179.2	41.8	52.3	83.7	104.6	125.5	156.9	167.3	209.1

TABLE A2. MAINTENANCE AND OIL CONSUMPTION

**ALTURDYNE INDUSTRIAL ROTARY ENGINE
STANDARD MAINTENANCE SCHEDULE**

Hours	Engine Air Cleaner	Engine Oil Filter	Spark Plugs	T.B.O.
50		X		
1000	X	X		
1500			X	
2000	X	X		
2500				
3000	X	X	X	
3500				
4000	X	X		
4500			X	
5000	X	X		
5500				
6000	X	X	X	
6500				
7000	X	X		
7500			X	
8000	X	X		
8500				
9000	X	X	X	
9500				
10000	X	X	X	X

**OIL CONSUMPTION
Gallons / 1000 Engine Hours**

	Natural Gas	Propane	Gasoline
1-ROTOR	12.5	12.5	25
2-ROTOR	25	25	50
3-ROTOR	37.5	37.5	75
4-ROTOR	50	50	100

APPENDIX B
AVS INFORMATION

AVS

Advanced Vehicle Systems, Inc.

HISTORY OF ADVANCED VEHICLE SYSTEMS, INC.

Advanced Vehicle Systems, Inc. (AVS) was organized in late 1992 in response to the Chattanooga Area Regional Transit Authority (CARTA) decision to request bids for a manufacturer to develop and produce battery powered electric transit vehicles. AVS was successful in winning the bid to produce 12 buses, 8 of which were of a size never before attempted anywhere in the world to our knowledge. Seven of the twelve buses have been completed and are in operation in downtown Chattanooga providing clean, efficient and quiet transportation.

AVS and its associate company SVMC are presently the leaders in a rapidly growing field of transportation technology that is receiving global attention.

AVS produces buses twenty two feet in length and thirty one feet in length. The buses are purpose built in Chattanooga "from the ground up" and contain features setting them apart from diesel buses in dramatic fashion. They are:

1. Low floored (12" ride height with less than 6" step from the curb). This provides easy access for passengers, particularly seniors and children.
2. Battery powered electric motor systems provide clean, quiet and efficient transportation in a manner highly accepted by passengers. There is no tailpipe and when in the battery powered mode it is a zero emission vehicle.
3. Operating costs (excluding operator) appear to be running at approximately 50% of conventional internal combustion powered buses.
4. A wheelchair ramp is built into the vehicle making it easily accessible for disabled individuals. The ramp is maintenance free.

Transit operators, power companies, local and national government officials and other interested groups from across the U.S.A. as well as internationally are coming to Chattanooga in increasing numbers to see CARTA's operation in downtown Chattanooga with vehicles AVS is producing. It would appear the interest being generated will literally birth a new industry in order to meet domestic and eventually international demand for these clean, efficient and quiet buses.

APPENDIX C
ELECTRONIC WIRING DIAGRAMS FOR ALTURDYNE APU

FORM NO.	REVISION	DATE	APPROVED
1	RELEASED	5-18-54	
2	ASSEMBLY AND TESTED	5-28-54	
3	AS INSTALLED	10-28-54	

1/17/85
 ADD TO THE...
 ADD REMOVED...
 RUN...
 BUS...
 CHAIRS...

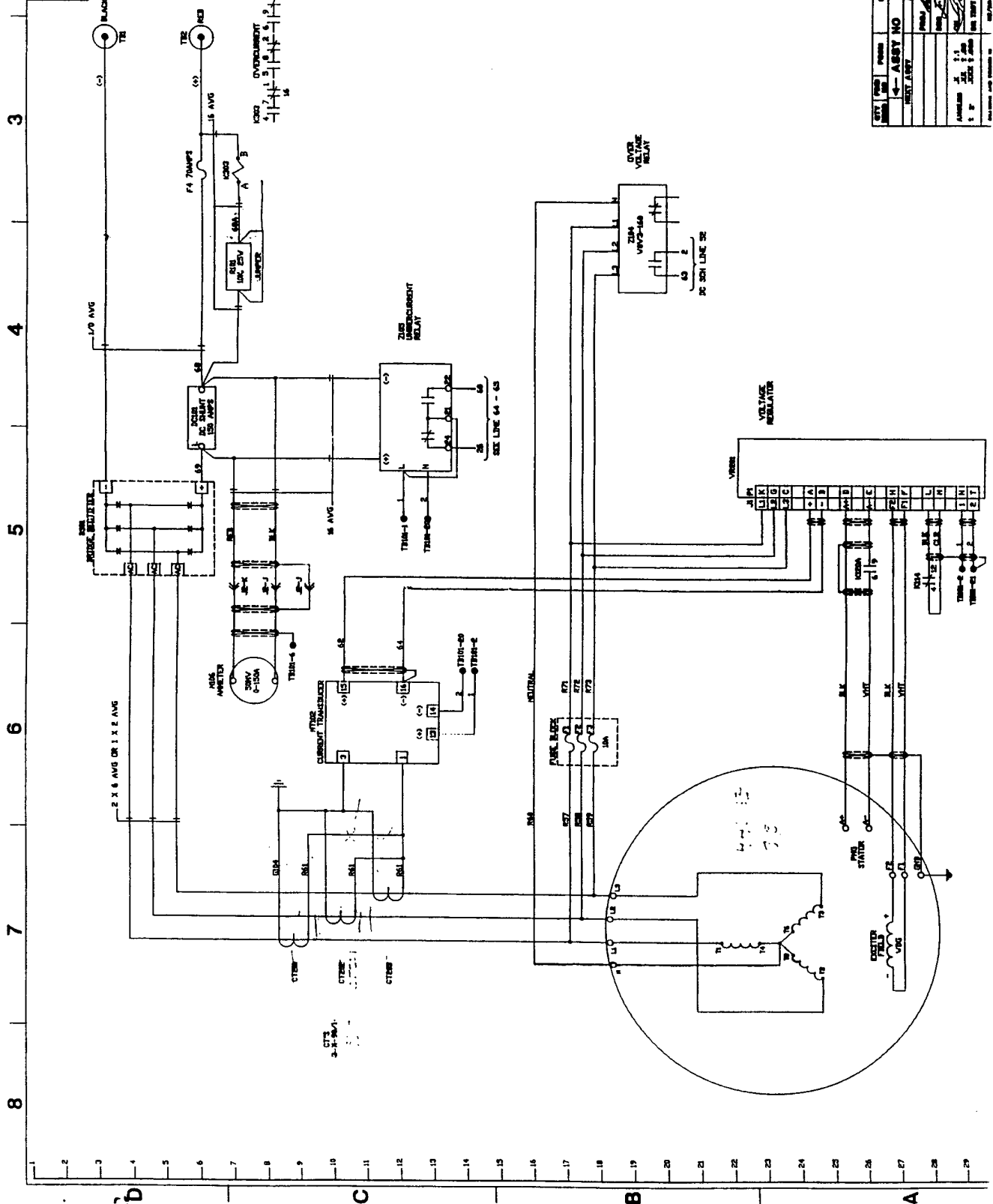

REV	NO	DATE	DESCRIPTION	PART NO	QUANTITY
1	1	5/18/54	ISSUED FOR PRODUCTION		
2	1	5/28/54	ISSUED FOR PRODUCTION		
3	1	10/28/54	ISSUED FOR PRODUCTION		

ALTURDYNE
26KW ROTARY ENGINE
LPG-BATTERY CHARGER
 260VDC/26VAC, 26A, 1.5W/400HZ

19800

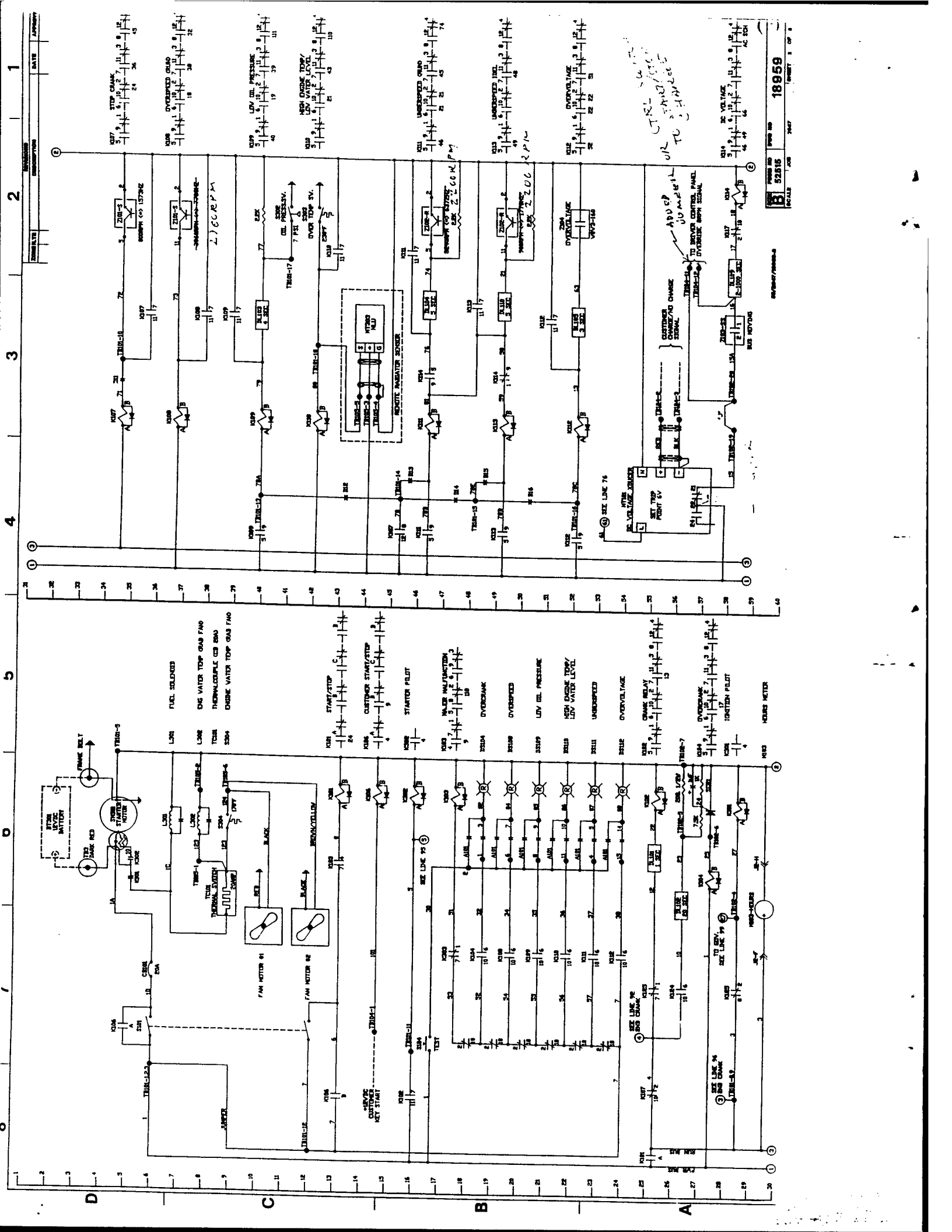

18959
 REV. 1
 DATE APPROVED
 1

2
 3
 4
 5

6
 7
 8
 9
 10
 11
 12
 13
 14
 15
 16
 17
 18
 19
 20
 21
 22
 23
 24
 25
 26
 27
 28
 29
 30

31
 32
 33
 34
 35
 36
 37
 38
 39
 40
 41
 42
 43
 44
 45
 46
 47
 48
 49
 50
 51
 52
 53
 54
 55
 56
 57
 58
 59
 60

61
 62
 63
 64
 65
 66
 67
 68
 69
 70
 71
 72
 73
 74
 75
 76
 77
 78
 79
 80
 81
 82
 83
 84
 85
 86
 87
 88
 89
 90
 91
 92
 93
 94
 95
 96
 97
 98
 99
 100

101
 102
 103
 104
 105
 106
 107
 108
 109
 110
 111
 112
 113
 114
 115
 116
 117
 118
 119
 120
 121
 122
 123
 124
 125
 126
 127
 128
 129
 130

131
 132
 133
 134
 135
 136
 137
 138
 139
 140
 141
 142
 143
 144
 145
 146
 147
 148
 149
 150
 151
 152
 153
 154
 155
 156
 157
 158
 159
 160

161
 162
 163
 164
 165
 166
 167
 168
 169
 170
 171
 172
 173
 174
 175
 176
 177
 178
 179
 180
 181
 182
 183
 184
 185
 186
 187
 188
 189
 190

191
 192
 193
 194
 195
 196
 197
 198
 199
 200
 201
 202
 203
 204
 205
 206
 207
 208
 209
 210
 211
 212
 213
 214
 215
 216
 217
 218
 219
 220

221
 222
 223
 224
 225
 226
 227
 228
 229
 230
 231
 232
 233
 234
 235
 236
 237
 238
 239
 240
 241
 242
 243
 244
 245
 246
 247
 248
 249
 250

18959
 REV. 1
 DATE APPROVED
 1

2
 3
 4
 5

6
 7
 8
 9
 10
 11
 12
 13
 14
 15
 16
 17
 18
 19
 20
 21
 22
 23
 24
 25
 26
 27
 28
 29
 30

31
 32
 33
 34
 35
 36
 37
 38
 39
 40
 41
 42
 43
 44
 45
 46
 47
 48
 49
 50
 51
 52
 53
 54
 55
 56
 57
 58
 59
 60

61
 62
 63
 64
 65
 66
 67
 68
 69
 70
 71
 72
 73
 74
 75
 76
 77
 78
 79
 80
 81
 82
 83
 84
 85
 86
 87
 88
 89
 90
 91
 92
 93
 94
 95
 96
 97
 98
 99
 100

101
 102
 103
 104
 105
 106
 107
 108
 109
 110
 111
 112
 113
 114
 115
 116
 117
 118
 119
 120
 121
 122
 123
 124
 125
 126
 127
 128
 129
 130

131
 132
 133
 134
 135
 136
 137
 138
 139
 140
 141
 142
 143
 144
 145
 146
 147
 148
 149
 150
 151
 152
 153
 154
 155
 156
 157
 158
 159
 160

161
 162
 163
 164
 165
 166
 167
 168
 169
 170
 171
 172
 173
 174
 175
 176
 177
 178
 179
 180
 181
 182
 183
 184
 185
 186
 187
 188
 189
 190

191
 192
 193
 194
 195
 196
 197
 198
 199
 200
 201
 202
 203
 204
 205
 206
 207
 208
 209
 210
 211
 212
 213
 214
 215
 216
 217
 218
 219
 220

221
 222
 223
 224
 225
 226
 227
 228
 229
 230
 231
 232
 233
 234
 235
 236
 237
 238
 239
 240
 241
 242
 243
 244
 245
 246
 247
 248
 249
 250

APPENDIX D
THERMOCOUPLE ASSIGNMENTS

APPENDIX E
ANALOG CHANNEL ASSIGNMENTS

A. V. S. ELECTRIC BUS

ANALOG CHANNEL ASSIGNMENTS

COLOR	CODE	CH	SENSORS	OUTPUT	MULTIPLIER	INPUT
BROWN	BLACK	1	GENERATOR CURRENT	6 VDC	100	600-AMP
RED	BLACK	2	BATTERY CURRENT	6 VDC	100	600 AMP
ORANGE	BLACK	3	MOTOR CURRENT	6 VDC	100	600-AM
YELLOW	BLACK	4	ACCESSORIES CURRENT	6 VDC	100	600-AMP
GREEN	BLACK	5	A/C MOTOR CURRENT	6 VDC	100	600-AMP
BLUE	BLACK	6	BATTERY VOLTAGE	5 VDC	60	0-300 V
WHITE	BLACK	7	VEHICLE SPEED	5 VDC	36.9749	432.7 Hz
BROWN	RED	8	ENGINE SPEED	5 VDC	1016.95	0-10 KHZ
ORANGE	RED	9	ACCELERATOR PEDAL	* 3-9 VDC	1	
YELLOW	RED	10	BRAKE PEDAL	* 3-9 VDC	1	
GREEN	RED	11				
BLUE	RED	12				
WHITE	RED	13				
ORANGE	GREEN	14				
YELLOW	GREEN	15				
BLUE	GREEN	16				

* NOMINAL

APPENDIX F
CURRENT-SENSOR PIN ASSIGNMENTS

A.V.S. ELECTRIC BUS
CURRENT-SENSOR PIN ASSIGNMENTS

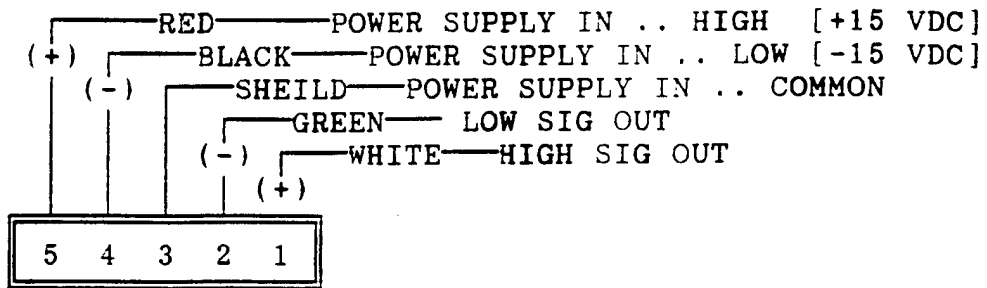

Current Sensor
(Physical representation)

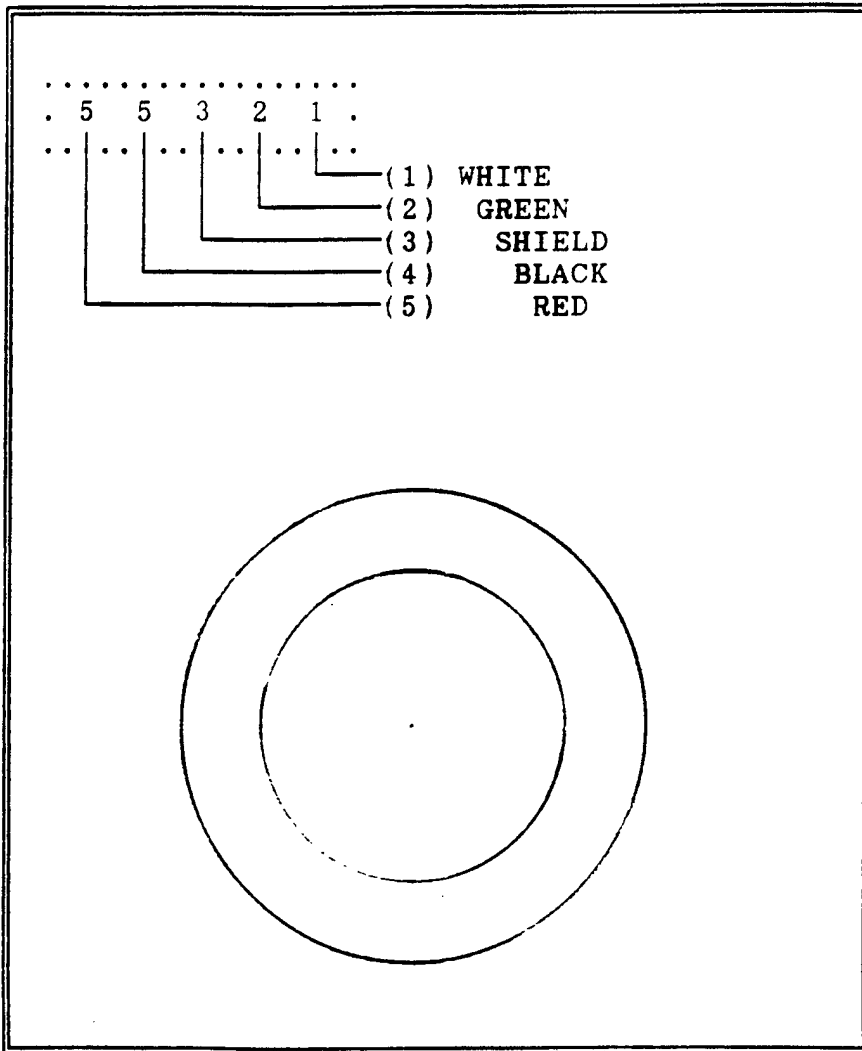

APPENDIX G
BRAKE AND ACCELERATOR PEDAL FUNCTION

M, N and O Brake potentiometer.

Connection O provides between 2 and 3.5v to the lower connection of the potentiometer, M provides between 6.5 and 10.5v to the top of the potentiometer. Connection N senses the voltage at the moving arm of the potentiometer. This will be between the voltages at M and O. When the brake pedal is released N is at the voltage of O and at the voltage of M when fully depressed. The drive system will malfunction if M, N or O become connected to the vehicle chassis or 12v. The position of the brake pedal defines the amount of regenerative braking supplied by the drive system.

P - Converter failed (ignition) lamp.
This line switches the vehicle ignition lamp. It is connected to 0v when the lamp is on.

Q - Converter on.
The converter is a sub-unit within the drive system, its function is to charge the vehicle 12V battery from the main battery pack. It is on when:-
1 - the drive system is operating.
2 - the charge plug is inserted, if this option is fitted.

When at 12v the "converter on" line will allow extra battery charging.

R - Converter step up.
When the converter is running its output voltage is defined by the voltage on this line. When open or at 0v the converter output is 14.3v and when at 12v the converter output is at 14.8v.

S, T, U and V - Continuous 12v.
These connections have two functions,

- 1 - to provide power from the 12v vehicle battery to the electronics within the drive system.
- 2 - to provide an output path for the converter to the 12v vehicle battery.

If this connection has failed permanently or intermittently the drive system will refuse to select drive direction.

If one of these connections becomes open circuit damage could result in the other connections as all four are required to cope with the converter output current.

Extra to this connector is the controller earth strap. This provides the converter with a return charge path via the vehicle chassis to the 12V battery.

- E - Regen override.
This line informs the controller whether the drive system is to use regenerative braking or not. When connected to 12v braking is enabled, when open circuit or connected to 0v braking is disabled. If a regen latch is fitted, as on the G-van, regenerative braking will remain off, until the accelerator pedal is depressed.
- F - Main battery low lamp.
This line controls the vehicle main battery low lamp. It is connected to 0v when the lamp is on and open circuit when off.
- G - State of charge gauge.
This is the drive system output to the state of charge gauge.
- H - Charge plug interlock-in.
This connection has the same function as plug interlock within the vehicle charge socket. When a charge plug is inserted this line is pulled to 0v, and open circuit when the plug is removed. At 0v the drive system and certain vehicle auxiliaries, such as air conditioning and power assisted systems, are all disabled.

DO NOT TRY TO ACCESS THIS SIGNAL FROM WITHIN THE VEHICLE CHARGE SOCKET AS DANGEROUSLY HIGH VOLTAGES ARE PRESENT ON THE OTHER PINS OF THIS SOCKET.

- I - Charge plug interlock-out.
This output turns vehicle auxiliaries off when the charge plug is inserted. The output is pulled towards 0v when systems are to be turned off.

J, K and L Accelerator potentiometer.

Connection L provides between 2 and 3.5v to the lower connection of the potentiometer, J provides between 6.5 and 10.5v to the top of the potentiometer. Connection K senses the voltage at the moving arm of the potentiometer. This will be between the voltages at J and L. When the accelerator pedal is released, K is at the voltage of L and at the voltage of J when fully depressed. The drive system will malfunction if J, K or L become connected to the vehicle chassis or 12v. The accelerator potentiometer has two modes of control of the drive system, when the accelerator pedal is fully released the drive system will regeneratively brake at the power defined by the brake potentiometer. As the pedal is depressed the drive system switches over to provide drive power at a level defined by the position of the pedal.

7296 CK .0AT G-4 9.00
 1653 AT .05AT 11.05 1.30

APPENDIX H
COLOR-CODED LINE FOR FREQUENCY-TO-VOLTAGE MODULES

A.V.S. ELECTRIC BUS
COLOR-CODE FOR F\V MODULES

MODULE	FUNCTION	PRIMARY COLOR (LOW SIG)	SECONDARY COLOR (HIGH SIG)	
1	SCT 302 V\V 500-VOLTS (0-5 VDC-OUT)	 — — — 	WHITE	
2	FDT 350 (LEFT) F\V MPH (0-5 VDC-OUT)		YELLOW	
3	FDT 350 (RIGHT) F\V RPM (0-5 VDC-OUT)		BROWN	
4	FDT 350 (LEFT) F\V MPH [1 KHz-INPUT]		BLACK	BLUE
5	FDT 350 (RIGHT) F\V RPM [10 KHz-INPUT]		GREEN	
6	(+\-) VDC [+15 & -15] ORANGE +15 VDC BLACK -15 VDC		(+) ORANGE (-) BLACK	
7	12 VDC POWER VEHICLE POWER To MODULES\P.S.		RED	
8	+/- 15VDC POWER POWER COMMON	 — — — 	WHITE & RED	
9	SCT 302 V\V 500 VDC [INPUT VOLTS]		YELLOW	
10			RED	BROWN
11			BLUE	
12			GREEN	

APPENDIX I
ADTECH ISOLATED POWER CONVERTER

A.V.S. ELECTRIC BUS
ADTECH-MODULE PIN ASSIGNMENTS

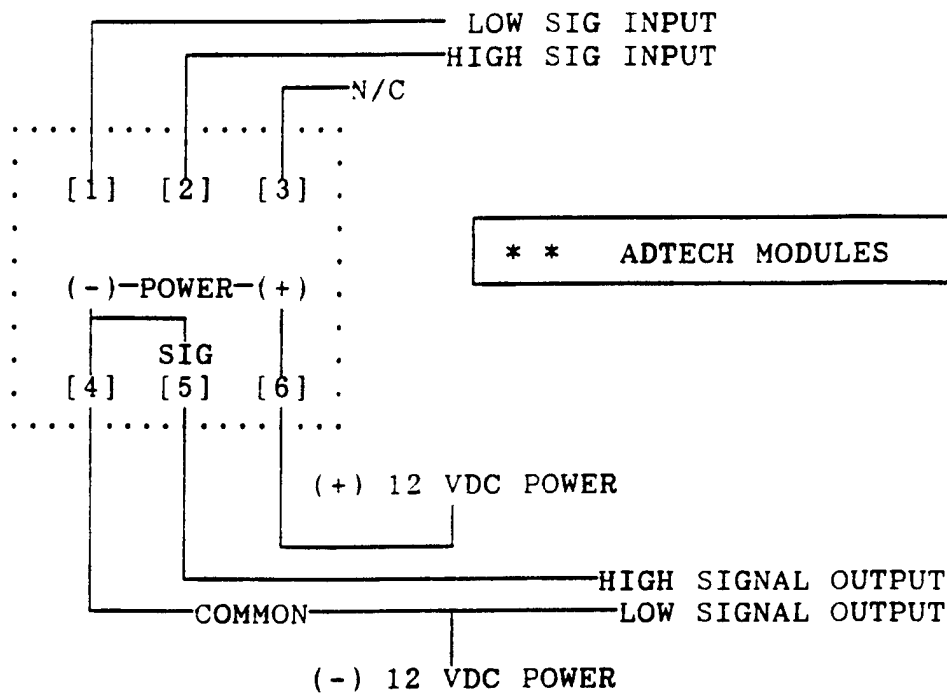

SCT-302	V\V .. REGEN VOLTS	
[1]	RED	LO SIG IN 300-VDC = 5-VDC
[2]	YELLOW	HIGH SIG IN
[3]	- - -	N/C
[4]	BLACK	COMMON (-) 12 VDC \ LO SIG OUT
[5]	WHITE	HIGH SIG OUT (0-5 VDC)
[6]	WHITE\RED	(+) 12 VDC POWER
FDT-350 (LEFT)	F\V .. VEHICLE SPEED (MPH)	
[1]	BLACK	LOW SIG IN { 1-KHz = 5-VDC }
[2]	BLUE	HIGH SIG IN {(432.7 Hz = 5-VDC)}
[3]	- - -	N/C
[4]	BLACK	COMMON (-) 12 VDC \ LOW SIG OUT
[5]	YELLOW	HIGH SIG OUT (0-5 VDC)
[6]	WHITE\RED	(+) 12 VDC POWER
FDT-350 (RIGHT)	F\V .. ENGINE SPEED (RPM)	
[1]	BLACK	LOW SIG IN 10-KHz = 5-VDC
[2]	GREEN	HIGH SIG IN
[3]	- - -	N/C
[4]	BLACK	COMMON (-) 12 VDC \ LOW SIG OUT
[5]	BROWN	HIGH SIG OUT (0-5 VDC)
[6]	WHITE\RED	(+) 12 VDC POWER



Analog-Digital Technology, Inc.
750 Monroe Avenue
Pittsford, New York 14534-1302
(716) 383-8280 • FAX (716) 383-8386

MODIFICATION SHEET FOR SCT 302L

SOUTHWEST RESEARCH, INC. P.O.# 45403, ADTECH S.O. # 12424

The input has been modified to provide a high voltage divider that reduces the maximum common mode voltage by 1/2. Additionally, the divider provides a current limiting function in the case of the transformer isolation being mechanically or electrically shorted. The highest value of current flow for a 300 VDC input is 150 μ Amps. The approximately 100 pf of primary to secondary transformer capacitance filters high voltage spikes of input common mode.

The SCT 302L block diagram below is shown with the input divider modification.

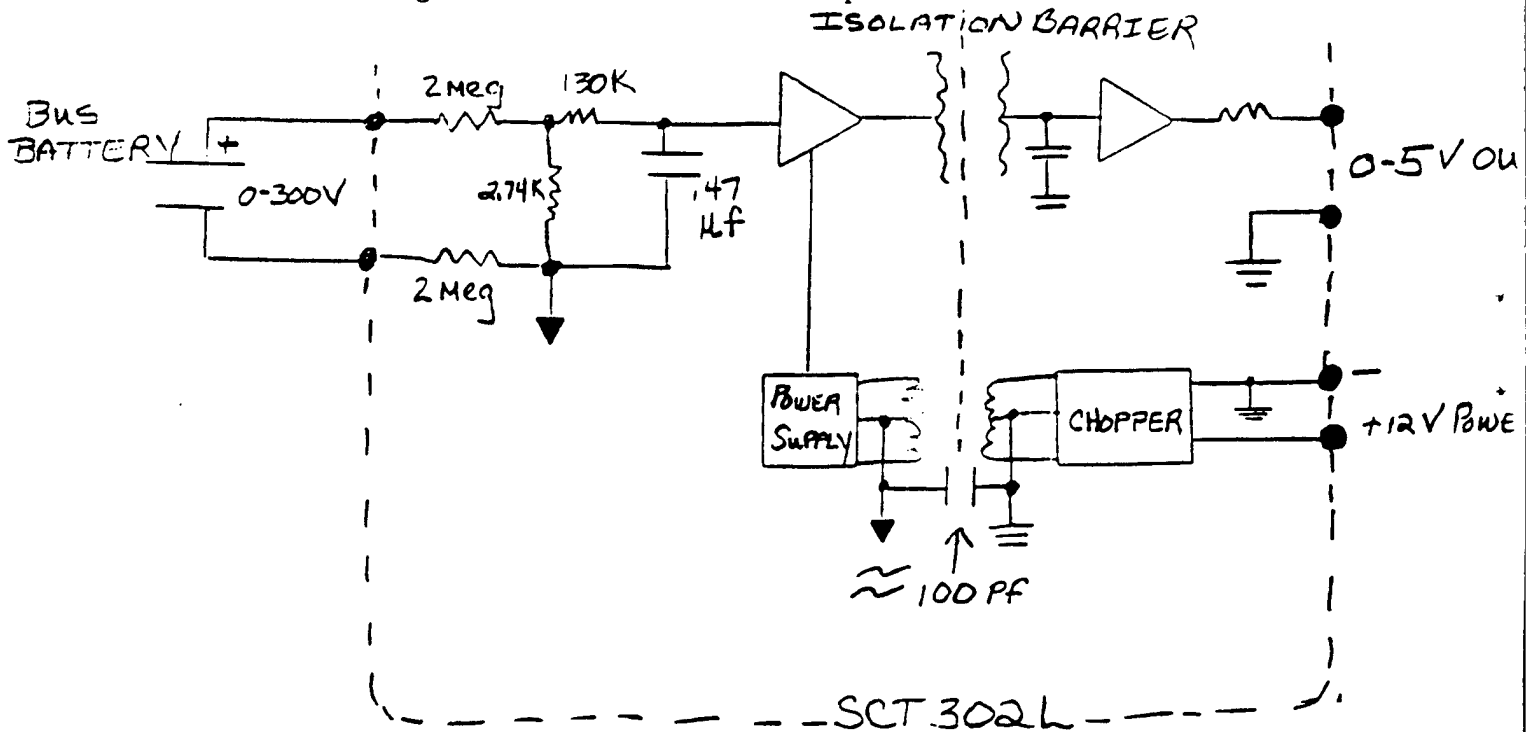

We have also attached our transformer specification drawing #130-A-000013, Revision C.

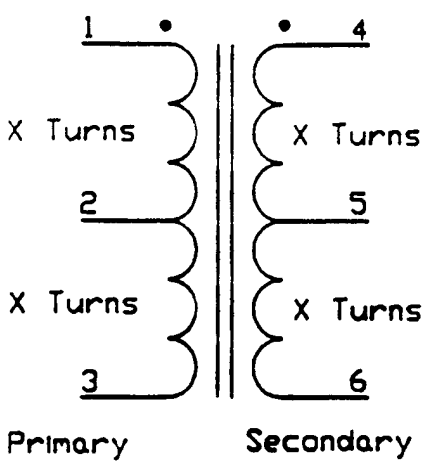
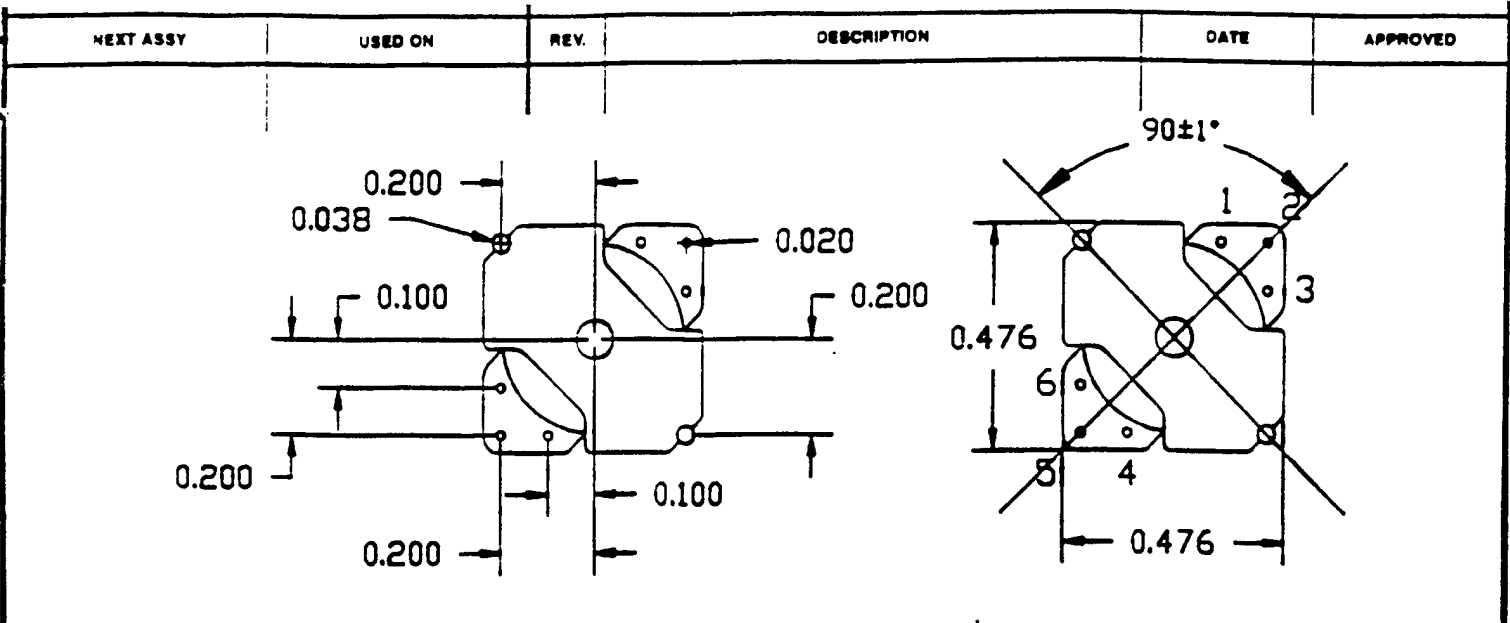

NOTE: To insure proper PCB insertion, the bobbin must be free to move within the core, or the alignment must conform to the dimensions above (90 degree angle between the mounting pins and the bobbin pins 2 and 5).
 If entire transformer is varnish coated, the 90±1° spec must be strictly met.

SPECIFICATIONS:

1. Inductance test 1khz @0.25V.
2. HIPOT 1500VAC PRI/SEC/CORE
3. MARK WITH PART NO. 562206-0000

CORE	BOBBIN	TURNS (X)	WIRE	Inductance mh		Resistance ohms	
				Pri 1-3	Sec 4-6	Pri 1-3	Sec 4-6
Ferroxcube R45PL00-387	Ferroxcube R5PC12-6	90 ±0	#36 Bifilar	64	64	6	8
Tdk H7C1RM5Z-52B	Tdk BRM5-716D	90 ±0	#36 Bifilar	64	64	6	8
Neosid 29-700-37	Tdk BRM5-716D	72 ±0	#36 Bifilar	64	64	6	8

OLD DRAWING: A-77000-0015

UNLESS OTHERWISE SPECIFIED DIMENSIONS ARE IN INCHES TOLERANCES ARE: FRACTIONS DECIMALS ANGLES ± .XX ± .XXX ± °	CONTRACT NO.		Rochester, New York, U.S.A. <small>ANALOG DIGITAL TECHNOLOGY INC</small>				
	APPROVALS	DATE					
MATERIAL	DRAWN	MRW	3/17/93	WIDE RANGING TWO WIRE TRANSFORMER			
FINISH	CHECKED	ISSUED					
DO NOT SCALE DRAWING				SIZE	FSCM NO.	DWG. NO. 130-A-000013	REV. C
				A			
				SCALE	TRANSFRM.DWG	SHEET	



ADTECH
Analog-Digital Technology, Inc.
2755 Montrose Avenue
Basking Ridge, N.J. 07004-1001
TEL: 908-852-8800 • FAX: 908-852-8386

SCT 302L Isolated Converter—DC Powered Instruction Manual

1.0 INTRODUCTION

These instructions refer to the above model. Supplementary sheets are attached if the unit has special options or features. For detailed specifications, see page 4 or refer to the Data Bulletin. All ADTECH instruments are factory calibrated and supplied with a label detailing the calibration. Adjustments are normally not necessary. A simple check should be performed to verify calibration before installation to ensure that it matches the field requirement.

2.0 GENERAL DESCRIPTION

The ADTECH SCT 302L is a low power Isolated Signal Transmitter that accepts process input signals such as 4-20 mA dc and converts them into a standard control signal output such as 1-5 vdc or 0-5 vac.

This model consumes very low power, typically 3.5 mA dc and is specially designed for remote battery or solar-panel-powered applications.

The input is electrically isolated from the output and the power supply by 600 volts ac or 1000 vdc peak. The SCT 302L is powered by 7-42 vac. The negative rail of the output is common with the negative rail of the dc power supply.

3.0 INSTALLATION

The instrument is supplied in a DIN rail mount general purpose enclosure as standard. NEMA 4 and 7 enclosures are optionally available. Installation area/location must agree with the supplied instruments including operating temperature and ambient conditions.

Electrical Connections

The wire used to connect the instrument to the control system I/O should be a twisted pair(s) and sized according to normal practice. Shielded cable is not normally necessary (if used, the shield must be grounded at the input negative of the ADTECH instrument and left floating at the sensor).

Six position compression terminal blocks are provided for I/O and power connection. A housing ground terminal is not required due to non-metallic housing.

Controls

Multiturn ZERO and SPAN controls are provided to calibrate the instrument. The multiturn controls are accessible through the instrument front panel and are clearly marked for ease of use. Other internal range selection jumpers are provided for ease of field rangeability.

4.0 MAINTENANCE

These instruments are electronic and require no maintenance except periodic cleaning and calibration verification. If the unit appears to be mis-operating it should be checked as installed per section 6.0 or removed for a bench check per sections 6.0-7.0. MOST problems are traced to field wiring and/or associated circuits. If the problem appears to be with the instrument, proceed to sections 7.0.

5.0 CONNECTIONS

Standard connections are shown below and on the instrument face plate. Data Bulletin or on attached supplementary sheets.



5.0 CONFIGURATION OF INPUT AND OUTPUT

All ADTECH units are factory calibrated per P. O. instructions. Usually, a complete recalibration is not required unless it is required to change input types, output types or the range of the unit. Most calibrations will only require a ZERO and SPAN fine adjustment.

NOTE: For recalibration to the existing range proceed to section 6.3; for new input or output range proceed as follows.

- A. Open the case to gain access to pcb boards. The larger pcb board is the input pcb and the smaller pcb is the output/power pcb.

6.1 INPUT CONFIGURATION

The ADTECH Model SCT 302L Isolated Voltage/Current Transmitter accepts both current and voltage inputs.

The SCT 302 has been set at the factory per the input/output marked on the label. It is easy to change the type of input. All inputs listed in Table 1 can be changed by simply selecting the appropriate header jumpers J2 to J8 on page 3.

6.2 OUTPUT CONFIGURATION

The output has been factory set as marked on the serial number tag. However, it is easy to change the type of output if so desired.

6.3 CALIBRATION

To perform a calibration check or re-calibration of the instrument follow this procedure.

- A. Make sure the unit I/O wiring is properly connected and that the correct power source per the label is also connected. The instrument must be at normal power for a minimum of 2 minutes before proceeding to B.
- B. The input signal source(s) must be adjustable from 0 to 100% in steps of 10% or at least 25%. The source(s) should be either precalibrated or an accurate meter must be used to monitor the input(s).
- C. The output may be monitored either as a direct voltage for a voltage output signal or as a current that can be read as a voltage across a resistor shunt e.g. 1-5 VDC across 250 ohms for 4-20 mA DC.
- D. Set the input source to minimum input value and adjust the multiturn potentiometer marked ZERO to provide the minimum calibrated output (e.g.) 4.00 ma \pm 0.01 ma dc. Note: For zero based outputs it is better to set input at 10% and adjust for 10% output for ZERO adjustment.
- E. Set the input source to maximum value and adjust the multiturn potentiometer marked SPAN to provide the maximum calibrated output (e.g.) 20.00 ma \pm 0.01 ma dc.
- F. Repeat steps D and E until readings are within calibration.
- G. The instrument should now be checked at 25-50-75% of span minimum for linearity.
- H. This completes the calibration.

7.0 FIELD TROUBLE SHOOTING GUIDE (300L Series)

This section offers a simple, first level trouble-shooting aid for an apparent instrument malfunction.

SYMPTOM

CORRECTIVE ACTION

No output

1. Check the input and output connections carefully.
2. Check that the power supply polarity is correct and that the output power is present on the indicated terminals.
3. Check that the input source(s) is correct and that it changes magnitude between zero and full scale values when so adjusted.
4. Make sure the output load is over 10k Ω and that the correct meter range is selected.

All external checks are complete. Problem seems to be internal.

The instrument is made of small components. Troubleshooting beyond the above may be difficult without special equipment. We do not recommend attempting repair of the unit in the field. ADTECH offers a very responsive repair policy. Contact the ADTECH factory for information on repair and return at 716-383-8280 or 716-383-8386 (FAX).

8.0 TABLES, PCB LAYOUT

Standard Inputs/Outputs

TABLE 1-INPUT

INPUT	J2	J3	J4	J7	J8
4 - 20 mA	A	B	B	B	A
0 - 20 mA	A	B	A	B	A
0 - 10 mA	A	B	A	C	A
0 - 1 mA	A	B	A	D	A
±20 mA	D	A	A	B	A
±10 mA	D	A	A	C	A
±1 mA	D	A	A	D	A
1 - 5V	A	B	B	A	B
0 - 5V	A	B	A	A	B
0 - 10V	A	B	A	A	C
±5V	D	A	A	A	B
±10V	D	A	A	A	C

TABLE 2-OUTPUT

Output Range	J6
1-5V	J6-A
0-5 vac	J6-B

Jumpers on larger pcb.

All jumpers located on larger pcb.

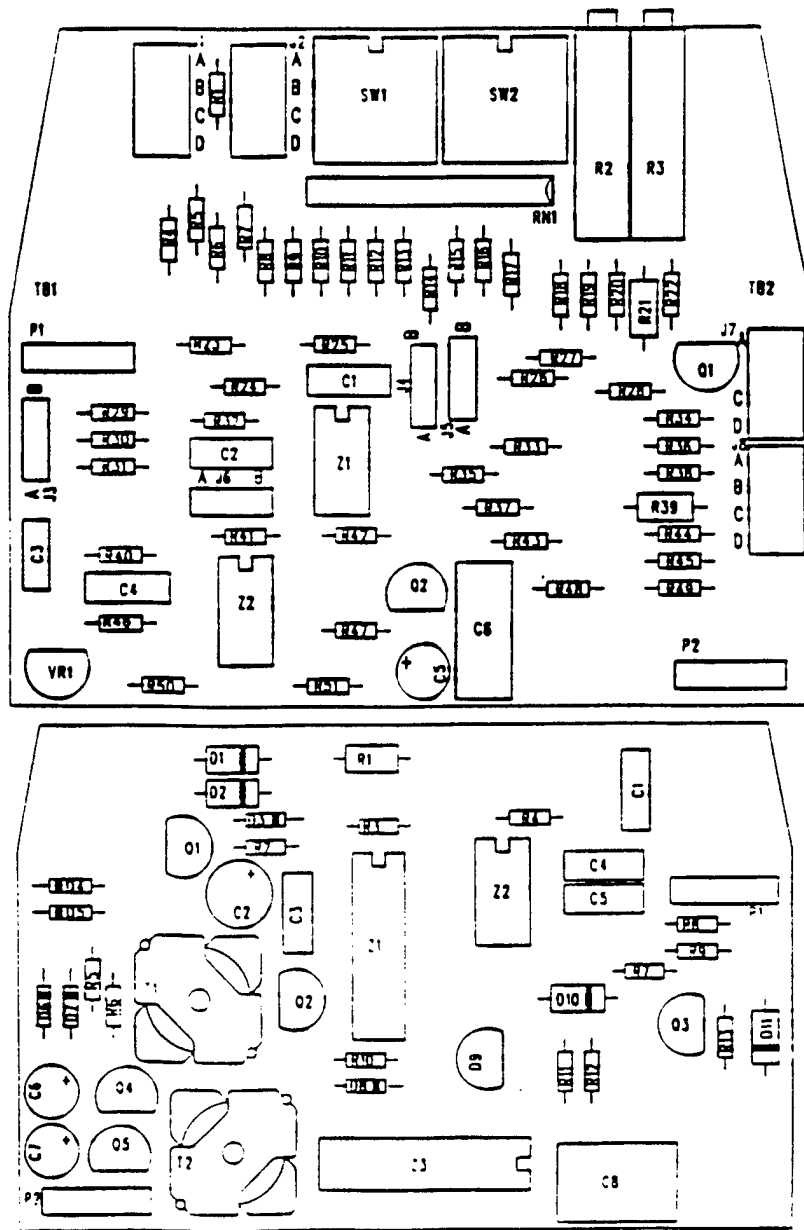

9.0 SPECIFICATIONS

INPUT/OUTPUT

INPUT SIGNALS

- a. 4-20 mA DC $Z \leq 10$ ohms)
 - b. 0-20 or ± 20 mA DC $Z \leq 10$ ohms)
 - c. 0-10 or ± 10 mA DC $Z \leq 20$ ohms)
 - d. 0-1 or ± 1 mA DC $Z \leq 200$ ohms)
 - e. 1-5 VDC $Z \leq 1$ megohm)
 - f. 0-5 or ± 5 VDC $Z \leq 1$ megohm)
 - g. 0-10 or ± 10 VDC $Z \leq 1$ megohm)
 - h. Any zero or bipolar voltage from 100 mV to 200 VDC (option 1-14)
- Zero Suppression: $\pm 10\%$
Span Adjustment: $\pm 10\%$

OUTPUT SIGNALS

0-5 VDC, 1-5 VDC

OUTPUT LOAD (R_L) = 10k Ω min.

PERFORMANCE

- a. Calibrated Accuracy: $\pm 0.1\%$
- b. Independent Linearity: $\pm 0.025\%$ max. $\pm 0.01\%$ typical
- c. Repeatability: $\pm 0.005\%$ max. $\pm 0.002\%$ typical
- e. Zero TC: $\pm 0.007\%$ of span max./ $^{\circ}$ C
- f. Span TC: $\pm 0.008\%$ of span max./ $^{\circ}$ C
- g. Load Effect: $\pm 0.005\%$ zero to full load
- n. Output Ripple: 10 mV P/P maximum
- n. Response Time: 110 milliseconds (10 to 90% step response)
- i. Bandwidth: (-3 db): 3.2 Hz
- j. Temperature Range: -25 $^{\circ}$ to 185 $^{\circ}$ F (-31 $^{\circ}$ to 85 $^{\circ}$ C) operating; -40 $^{\circ}$ to 200 $^{\circ}$ F (-40 $^{\circ}$ to 93 $^{\circ}$ C) storage
- k. Power Supply Effect: $\pm 0.005\%$ of span, max.
- l. Isolation: input/output/case: 1000 VDC or 600 VAC

Note: All accuracies are given as a percentage of span

POWER

- a. 7-42 vdc: 3.5 mA typical, 5 mA max.

10.0 OUTLINE & MOUNTING

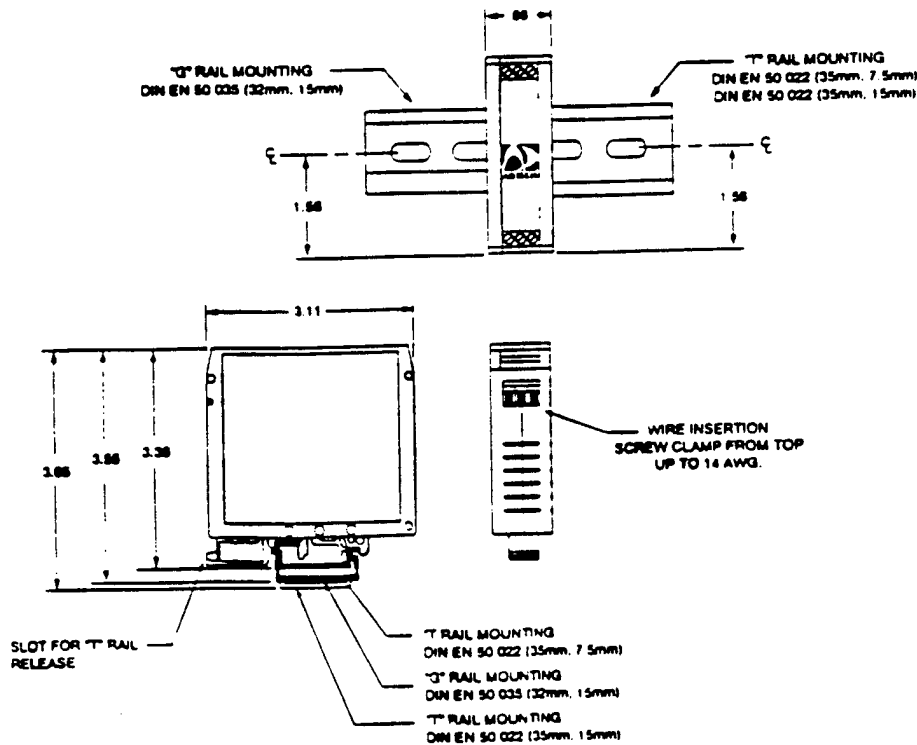



1.0 INTRODUCTION

These instructions refer to the above model. Supplementary sheets are attached if the unit has special options or features. For detailed specifications, see page 4 or refer to the Data Bulletin. All ADTECH instruments are factory calibrated and supplied with a label detailing the calibration. Adjustments are normally not necessary. A simple check should be performed to verify calibration before installation to ensure that it matches the field requirement.

2.0 GENERAL DESCRIPTION

The ADTECH MODEL FDT-350L LOW POWER Frequency to DC Transmitter provides high accuracy conversion of frequency or pulse rate inputs to standard process signal 0-5 vdc or 1-5 vdc or zero based outputs.

This model consumes very low power typically 3.5 mAdc and is specially designed for remote battery or solar panel powered applications.

This instrument is powered by 7-42 vdc supply. The negative of the power and the output share a common connection. This is the reason it is called a three wire transmitter.

The input waveform may be sinusoidal, triangular or any pulse shape that is periodic. The input signal may be between 10 mv to 100 VRMS voltage or a dry contact rated at 2 mA, 24 vdc. For a contact input a jumper is installed between terminals 2 & 3.

The input is electrically isolated from the output and the power supply by 600 volts ac or 1000 volts dc peak.

Standard features include both hysteresis and sensitivity adjustments for noise rejection; built in adaptive digital filtering for improved contact bounce and signal noise immunity.

ZERO, SPAN, SENSITIVITY and HYSTERESIS controls are provided by infinite resolution potentiometers. Recalibration to other ranges is very convenient. ZERO and SPAN are totally independent of each other, enhancing the calibration process.

3.0 INSTALLATION

Electrical Connections

The wire used to connect the instrument to the control system I/O should be a twisted pair(s) and sized according to normal practice. Shielded cable is not normally necessary (if used, the shield must be grounded at the input negative of the ADTECH instrument and left floating at the sensor).

Six position compression terminal blocks are provided for I/O and power connection. A housing ground terminal is not required due to non-metallic housing.

Controls

Instrument controls consists of the following:

- One 16 position rotary switch for Major Range.
- Four multiturn potentiometers for Zero, Span, Hysteresis and Sensitivity.
- One 2 position jumper for Output Zero Type.
- Two 4 position jumpers for Output Type.

4.0 MAINTENANCE

These instruments are electronic and require no maintenance except periodic cleaning and calibration verification. If the unit appears to be mis-operating it should be checked as installed per section 6.0 or removed for a bench check per sections 6.0 and 7.0. MOST problems are traced to field wiring and / or associated circuits. If the problem appears to be with the instrument, proceed to sections 6.0 and 7.0.

5.0 CONNECTIONS

Standard connections are shown below and on the instrument face plate. Data Bulletin or on attached supplementary sheets.

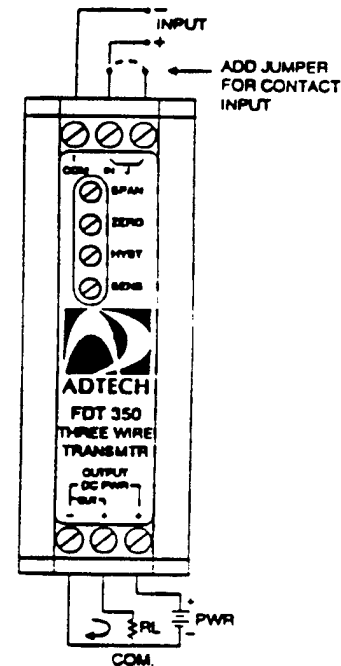

NOTE: For contact input install jumper from terminals 2 to 3.

6.0 CONFIGURATION OF INPUT AND OUTPUT

All ADTECH units are factory calibrated per P.O. instructions. Usually, a complete recalibration is not required unless you want to change input type, output type, or the range of the unit. A calibration sticker located on the unit identifies the model, calibration and options present.

NOTE: For recalibration to the existing range proceed to section 6.1; for new input or output range proceed as follows.

- A. Open the case to gain access to the pc boards. The larger pc board is the input pcb and the smaller pc board is the output/power pcb.
- B. FDT 350L is capable of both zero based and 20% elevated output zeroes. Follow Table 2 for the correct Output Zero Jumper. For example, a 1 to 5 volt output would be considered a 20% elevated output, while a 0 to 5 volt output would be a zero based output.
- C. From Input Table 1, adjust the 16 position switch(SWI) so that the frequency range is equal to just higher than the maximum input frequency signal.
- D. To select the desired output type, follow Output Table 2.
- E. Close the case and calibrate per 6.1.

6.1 CALIBRATION

- A. Make sure the unit I/O wiring is properly connected and that the correct power source per label is connected. The unit must be powered for a minimum of 2 minutes prior to proceeding.
- B. The input source must be adjustable from 0 to 100% in steps of 10% or at least 25%. The source should either be precalibrated or an accurate meter must be used to monitor the input.
- C. The output may be monitored as a current that can be represented as a voltage across a resistor shunt.
- D. Under normal condition only one input control (Hysteresis or Sensitivity) are required for proper operation of the unit. Follow below for the correct setting of the two controls for proper input threshold:
 1. If the minimum input signal level is 1 volt or less, turn the SENSITIVITY control fully clockwise. You need adjust the HYSTERESIS for proper operation.
 2. If the minimum input signal is greater than 1 volt, turn the HYSTERESIS control fully clockwise. Only the SENSITIVITY control is required for proper operation.
- E. Adjust the signal to the minimum input voltage, and set the frequency at about midscale. Adjust the HYSTERESIS control if the minimum input signal is less than 1 volt or less (SENSITIVITY control if the input signal is greater than 1 volt) to the point where the unit just starts operating. (The output will be about midscale.) Give the adjustment an additional 1/4 to 1/2 turn to allow for input signal variations.
- F. With 0% input (or input shorted) adjust the ZERO control for zero output (4.00 mA. for 4-20 mA out) and the desired accuracy.
- G. With a 100% input signal at the operating voltage level, adjust the SPAN control for full scale output (20 mA. for 4-20 mA out) and the desired accuracy.

H. Repeat steps E and F until the readings remain within the desired calibration accuracy.

I. Check the instrument at the 25-50-75% input settings.

7.0 FIELD TROUBLE SHOOTING GUIDE (300L SERIES)

This section offers a simple, first level trouble-shooting aid for an apparent instrument malfunction.

SYMPTOM

CORRECTIVE ACTION

No output

1. Check the input and output connections carefully.
2. Check that the power supply polarity is correct and that the output power is present on the indicated terminals.
3. Check that the input source(s) is correct and that it changes magnitude between zero and full scale values when so adjusted.
4. Make sure the output load is over 10 k Ω and that the correct meter range is selected.

All external checks are complete. Problem seems to be internal.

The instrument is made of small components. Troubleshooting beyond the above may be difficult without special equipment. We do not recommend attempting repair of the unit in the field. ADTECH offers a very responsive repair policy. Contact the ADTECH factory for information on repair and return at 716-383-8280 or 716-3883-8386 (FAX).

8.0 TABLES. PCB LAYOUT

INPUT TABLE 1

Major Range	
Rotary Switch Position	Frequency Range Hz
F	30.000
E	15.000
D	7.500
C	3.750
B	1.875
A	937.5
9	468.8
8	234.4
7	117.2
6	58.59
5	29.30

OUTPUT RANGE TABLE 2

1-5 vac	J1-A
0-5 vac	J1-B

402.7 Hz = 0-5 V

Switch located on input pcb.

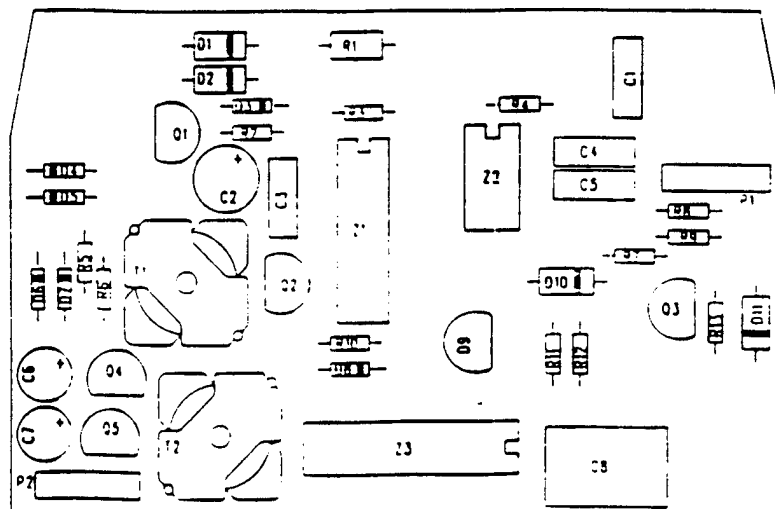
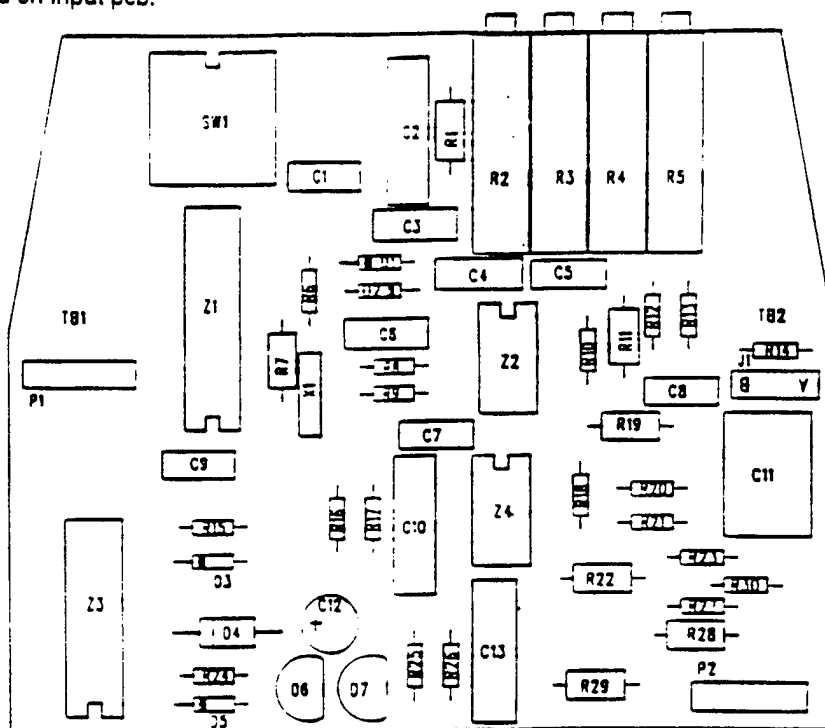

9.0 SPECIFICATIONS

INPUT/OUTPUT

INPUT SIGNALS

- a. Voltage (Amplitude): 10 mv to 100 vrms (0-5 KHz)
50 mv to 50 vrms (5 KHz to 30 KHz)
- b. Contact: Dry, 2 ma @ 24 vac rating
- c. Frequency Range: 0-30 Hz to 0-30 KHz Full Scale
- d. Major Range Switch provides 11 discrete ranges with the ZERO control adjustable $\pm 10\%$ of output and the SPAN control adjustable from 50% to 100% of the major range selected

OUTPUT SIGNALS

0-5 vdc, 1-5 vdc.

OUTPUT LOAD (RL) = 10k Ω min.

PERFORMANCE

- a. Calibrated Accuracy: $\pm 0.1\%$
- b. Independent Linearity: $\pm 0.02\%$ maximum,
 $\pm 0.01\%$ typical
- c. Repeatability: $\pm 0.005\%$ maximum; $\pm 0.002\%$ typical
- d. Zero TC: $\pm 0.01\%$ of span max $^{\circ}$ C
- e. Span TC: $\pm 0.01\%$ of span max $^{\circ}$ C
- f. Load Effect: $\pm 0.005\%$ zero to full load
- g. Output Ripple: 10 mv P/P maximum

- h. Response Time: 350 milliseconds (10 to 90% step response)
 - i. Bandwidth: (-3 db): 1 Hz
 - j. Temperature Range: -25 $^{\circ}$ to 185 $^{\circ}$ F (-31 $^{\circ}$ to 85 $^{\circ}$ C) operating
-40 $^{\circ}$ to 200 $^{\circ}$ F (-40 $^{\circ}$ to 93 $^{\circ}$ C) storage
 - k. Power Supply Effect: $\pm 0.005\%$ over operating range
 - l. Isolation: Input/output/case: 600 VAC, 1000 VDC
- Note: All accuracies are given as a percentage of span

POWER

- a. 7 to 42 vdc—3.5 mA typical, 5 mA max

MECHANICAL

- a. Electrical Classification: general purpose
- b. Connection: Screw, compression type, accepts up to 14 AWG
- c. Controls: One 16 position rotary switches for range control
Four multiturn potentiometers for ZERO, SPAN, SENSITIVITY, and HYSTERESIS control
- d. Mounting: Surface, Snap-Track, DIN or NEMA 4 & 7
- e. Weight: Net Unit: 4 oz. (115 grams)
Shipping: Nominal 7 oz. (200 grams)

OPTIONS

Option Number	Description
H 15D through H 30	Mounting

10.0 OUTLINE & MOUNTING

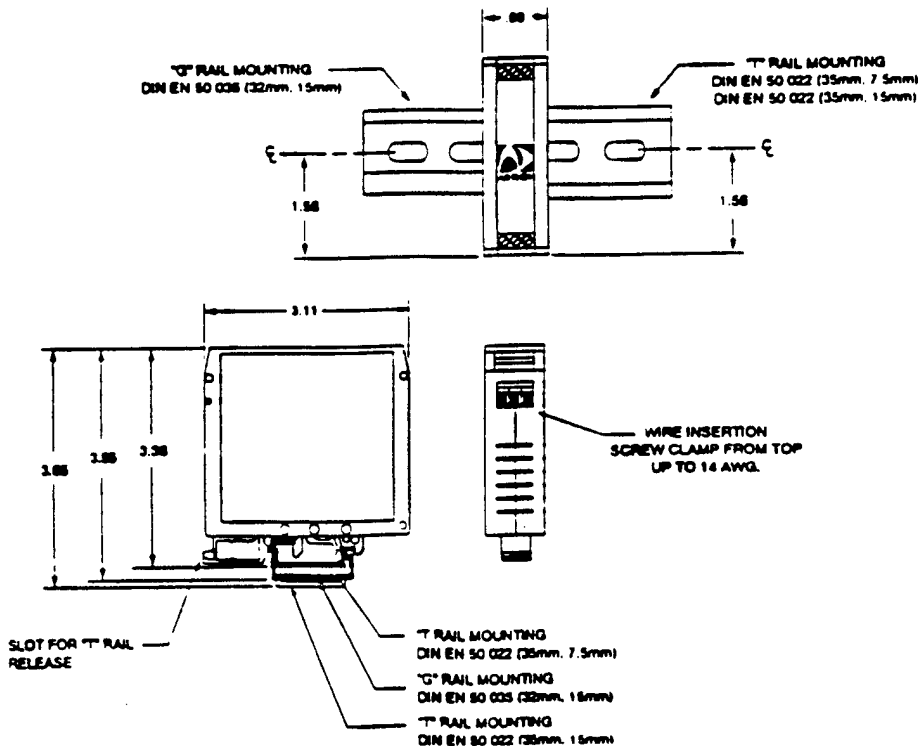

- **Fast response**
- **Extended Frequency Range**
- **Low Offset Temperature Drift**
- **Overrange Capability**

$\pm 600A$

$\pm 6V$

needs $\pm 15V$

MECHANICAL DIMENSIONS

ALL DIMENSIONS ARE IN INCHES (MILLIMETERS)

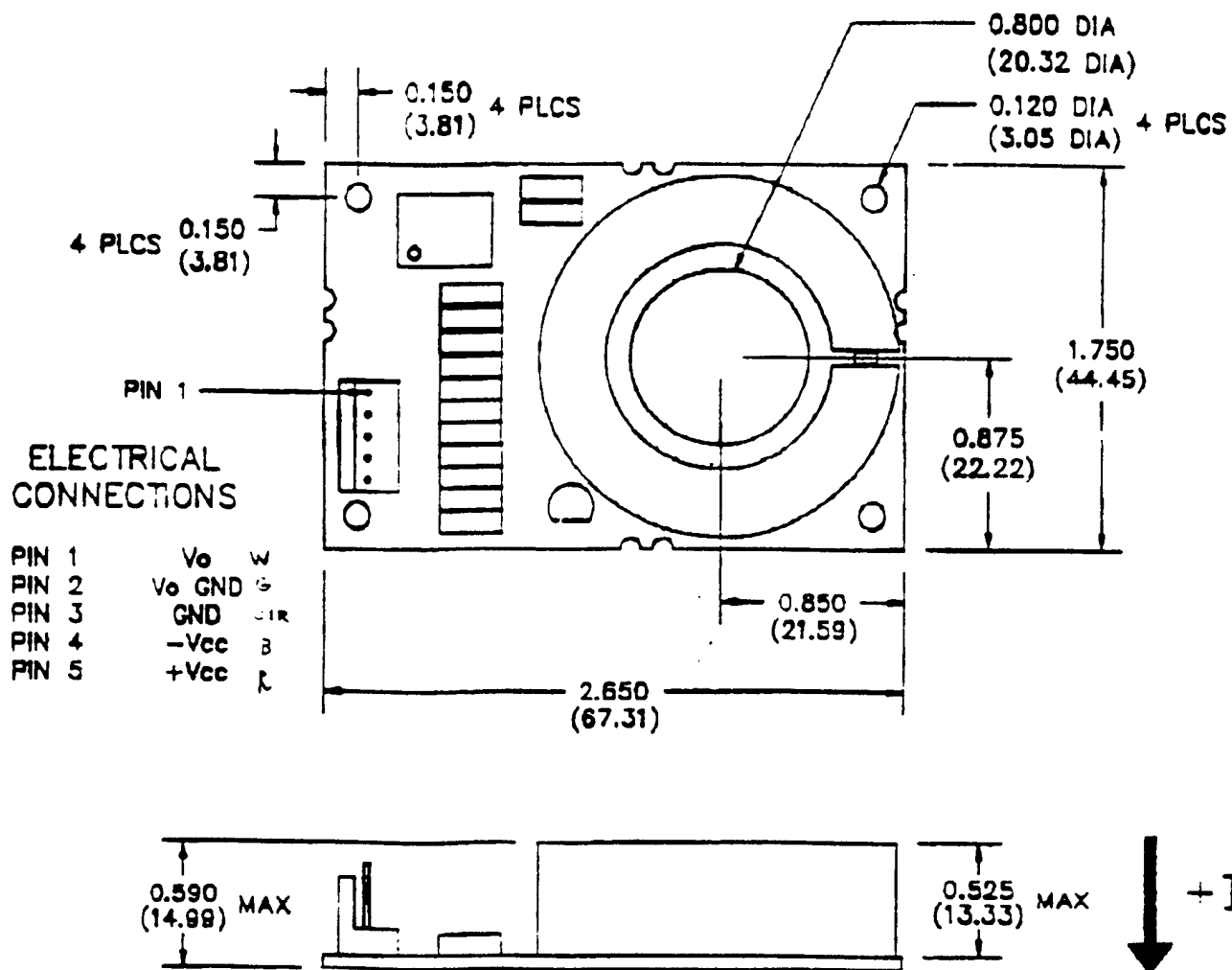

Mating Connector: PANDUIT Model No. CE100F26-5

Description:

The B.B. Series Hall effect current sensors accurately measure dc and ac currents with the advantage of offering electrical isolation between the output of the sensor and the current carrying conductor

Measuring Circuit

	Units	BB-150	BB-300	BB-600
Full Scale (FS) dc or ac peak	$\pm A$	150	300	600
Full scale output	$\pm V$	-----	6.0	-----
AC Bandwidth (± 1 dB) (1)	kHz	60	10	10
Response time (2)	μs	< 2	< 3	< 3
Slew Rate	A/ μs	> 60	> 50	> 50

Excitation Circuit

Supply voltage	$\pm VDC$	-----	15	-----
Maximum supply current, positive supply	mA	-----	6	-----
Maximum supply current, negative supply	mA	15	10	10

Output

Sensitivity	mV/A	40	20	10
Linearity	\pm % FS	0.6	0.7	1.25
Calibration point (3)	\pm % RDG	-----	1.25	-----
Typical zero current offset	\pm mV	-----	5	-----
Maximum zero current offset	\pm mV	-----	20	-----
Maximum hysteresis of offset (4)	\pm mV	35	20	15
Minimum load resistance	kohms	-----	2	-----

Influences on Accuracy

Typical offset drift with temperature	\pm mV/ $^{\circ}C$	0.30	0.15	0.15
Maximum offset drift with temperature	\pm mV/ $^{\circ}C$	1.50	1.00	0.50
Excitation change of ± 1 % - Max. sensitivity change	\pm %	-----	0.15	-----
Typical sensitivity drift with temperature	\pm %/ $^{\circ}C$	-----	0.04	-----
Maximum sensitivity drift with temperature	\pm %/ $^{\circ}C$	-----	0.065	-----

Withstand Capabilities

Dielectric test (5)	kV	-----	1.0	-----
Output short or open circuit		NO DAMAGE		

General Information

Operating temperature range	$^{\circ}C$	-----	-25 to +85	-----
Storage temperature range	$^{\circ}C$	-----	-40 to +95	-----
Aperture opening	inches (mm)	-----	0.80 (20.3)	-----
Weight	grams	-----	60	-----
Mounting	Four mounting holes 0.120" diameter			
Output reference	To obtain a positive output on pin marked "Vo", positive conventional current must flow into the component side (See mechanical dimensions)			

Notes:

- (1) Consult F.W. Bell if the product of the aperture current and frequency exceeds 1000 ampere-kilohertz for the BB-150 and 400 ampere-kilohertz for the BB-300 and BB-600.
- (2) Response time is effected by the positioning of the conductor in the aperture, the proximity of the return conductor and ferrous metals. It is best to test the sensor in the actual environment to obtain representative performance.
- (3) The sensors are calibrated at 80% of Full Scale.
- (4) Hysteresis specifications given for a Full Scale aperture current remnant.
- (5) The dielectric test consists of 1.0 kVac at 60 Hz for one minute between a bare 0.775 inch diameter conductor (located concentrically through the aperture) and the output of the sensor.



ALTURDYNE

8050 Armour Street
San Diego, CA 92111
(619) 565-2131
FAX (619) 279-4296

FAX

FAX NO. 210 522-5720	COMPANY <i>SWRI</i>
ATTN <i>Scott Mc Broom</i>	FROM <i>Scott DUFFY</i>
SUBJECT <i>SIGNALS FOR DATA ACQUISITION</i>	
DATE <i>12-8-94</i> JOB NO. <i>2047</i>	PAGES (including cover sht) <i>3</i>

Scott

#5 Vehicle speed - I have to find the freq. range.

AS

60 miles C 1REV = 3.7961 FT
Hour

4 teeth
45 MPH
7.0 RAD
14.5"

12-8-94

#1 OIL PRESSURE SIGNAL :

Signal is NOT defined

GAGE : VDO PART # 350-508

RANGE 0 - 150 psi

Sender : VDO PART # 360-083

RANGE 0 - 150 psi

WIRE TAP AT GAGE "S" REF. WIRE # 49

#2 WATER TEMP SIGNAL :

SIGNAL IS NOT DEFINED

GAGE : VDO PART # 310-502

RANGE 100 - 250 °F

SENDER : VDO PART # 323-095

RANGE 100 - 250 °F

WIRE TAP AT GAGE "S" REF. WIRE # 50

#3 ENGINE SPEED :

MAGNETIC PICK UP ON ENGINE FLYWHEEL TEETH
FLYWHEEL 118 T_S

$$\text{ENG. RPM} = [\text{FREQUENCY (Hz)}] \left[\frac{60}{118} \right] = [1.508] [\text{FREQ (Hz)}]$$

WIRE TAP
+ TB102 - 1
- TB102 - 2
SHIELD TB102 - 3 10000
500

#4 OIL TEMP SIGNAL

SIGNAL IS NOT DEFINED

GAGE: VDO PART # 710-510

RANGE 150-300 °F

Sender: VDO PART # 323-058

RANGE 150-200 °F

#5 VEHICLE SPEED SIGNAL

MAGNETIC PICKUP ON VEHICLE DRIVE SHAFT

Drive shaft ——— TR } 568 28MM COX
Vehicle speed = 14.5

WIRE TAP + TB104-13
- TB104-14
SM610 TB104-15

#6 AMMETER (VIA SHUNT)

SIGNAL: 0-50 MV

RANGE: 0-150 AMPS

WIRE TAP AT GAGE OR SHUNT

#7 VOLTAGE

SIGNAL NOMINAL ± 216 VDC

WIRE TAP ± HUGS ON TOP OF UNIT

APPENDIX J
NEMA ENCLOSURE



**Manufacturer of
Electrical Enclosures
& Wireway**

10000 W. Commerce
San Antonio, Texas 78227
(512) 673-3680
FAX 673-3883

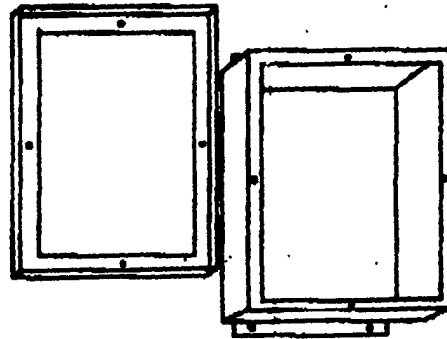

standard sizes

W	H	4"d	6"d	8"d	10"d
4	4	11.28			
4	6	15.00			
6	6	16.68	20.04		
6	8	23.22	27.54		
6	10	24.00	30.00		
6	12	27.30	37.50		
8	8	24.90	26.82	34.68	
8	10	31.20	34.14	40.92	
8	12	37.50	41.70	50.04	
10	10	34.50	40.92	45.00	52.50
10	12	41.28	45.00	56.28	58.50
12	12	45.00	48.90	58.38	62.52
12	16	54.00	58.50	69.00	79.50
12	18	62.52	69.00	75.00	87.54
12	24	75.00	82.50	90.00	105.00
18	18	81.30	87.60	93.78	106.20
18	24	97.50	105.00	127.50	142.50
24	24	120.00	150.00	180.00	202.50
24	30	150.00	187.50	206.28	225.00
24	36	175.02	200.10	212.52	249.00
30	30		206.78		300.00
30	36				375.00

* list price is for 14ga. steel, painted

nema 12

Nema Type 12 Oil-Tight JIC Enclosures

Application

EPI NEMA Type 12 Oil-Tight JIC enclosures are designed for use as instrument housings, electrical control enclosures, terminal wiring boxes, and electrical junction boxes. They provide protection from dust, dirt, oil, and water.

Construction

These enclosures are made from 14 gauge steel. All seams are continuously welded and there are no holes or knockouts. The covers are attached with self-captivating screws. Covers are gasketed with a neoprene gasket attached with an oil-resistant adhesive. External feet are furnished for mounting. Weld nuts are provided for optional mounting panel, otherwise not installed. Panels must be ordered separately as they are not furnished with the enclosure. The panels are made from 14 gauge steel.

Finish

The standard finish is ASA-61, light-dove gray enamel inside and out. Enclosures are also available in galvanize steel.

Industry Standard

Conforms to the National Electrical Manufacturers Association (NEMA) standard for Type 12 (Industrial use) enclosures. Also conforms to the Joint Industrial Council (JIC) standards EGP--1-1967.

Department of the Army

PROG EXEC OFFICER		CDR AEC	
ARMORED SYS MODERNIZATION		ATTN: SFIM AEC ECC (T ECCLES)	1
ATTN: SFAE ASM S	1	APG MD 21010-5401	
SFAE ASM H	1		
SFAE ASM AB	1	CDR ARMY SOLDIER SPT CMD	
SFAE ASM BV	1	ATTN: SATNC US (J SIEGEL)	1
SFAE ASM CV	1	SATNC UE	1
SFAE ASM AG	1	NATICK MA 01760-5018	
CDR TACOM			
WARREN MI 48397-5000		CDR ARMY ARDEC	
		ATTN: AMSTA AR EDE S	1
PROG EXEC OFFICER		PICATINNY ARSENAL	
ARMORED SYS MODERNIZATION		NJ 07808-5000	
ATTN: SFAE FAS AL	1		
SFAE FAS PAL	1	CDR ARMY WATERVLIET ARSN	
PICATINNY ARSENAL		ATTN: SARWY RDD	1
NJ 07806-5000		WATERVLIET NY 12189	
PROG EXEC OFFICER		CDR APC	
TACTICAL WHEELED VEHICLES		ATTN: SATPC L	1
ATTN: SFAE TWV TVSP	1	SATPC Q	1
SFAE TWV FMTV	1	NEW CUMBERLAND PA 17070-5005	
SFAE TWV PLS	1		
CDR TACOM		CDR ARMY LEA	
WARREN MI 48397-5000		ATTN: LOEA PL	1
		NEW CUMBERLAND PA 17070-5007	
PROG EXEC OFFICER		CDR ARMY TECOM	
ARMAMENTS		ATTN: AMSTE TA R	1
ATTN: SFAE AR HIP	1	AMSTE TC D	1
SFAE AR TMA	1	AMSTE EQ	1
PICATINNY ARSENAL		APG MD 21005-5006	
NJ 07806-5000			
PROG MGR		PROJ MGR MOBILE ELEC PWR	
UNMANNED GROUND VEH		ATTN: AMCPM MEP T	1
ATTN: AMCPM UG	1	AMCPM MEP L	1
REDSTONE ARSENAL		7798 CISSNA RD STE 200	
AL 35898-8060		SPRINGFIELD VA 22150-3199	
DIR		CDR	
ARMY RSCH LAB		ARMY COLD REGION TEST CTR	
ATTN: AMSRL PB P	1	ATTN: STECR TM	1
2800 POWDER MILL RD		STECR LG	1
ADELPHIA MD 20783-1145		APO AP 96508-7850	
VEHICLE PROPULSION DIR		CDR ARMY ORDN CTR	
ATTN: AMSRL VP (MS 77 12)	1	ATTN: ATSL CD CS	1
NASA LEWIS RSCH CTR		APG MD 21005	
21000 BROOKPARK RD			
CLEVELAND OH 44135		CDR 49TH QM GROUP	
		ATTN: AFFL GC	1
CDR AMSAA		FT LEE VA 23801-5119	
ATTN: AMXSY CM	1		
AMXSY L	1	CDR	
APG MD 21005-5071		ARMY BIOMED RSCH DEV LAB	
		ATTN: SGRD UBZ A	1
CDR ARO		FT DETRICK MD 21702-5010	
ATTN: AMXRO EN (D MANN)	1		
RSCH TRIANGLE PK			
NC 27709-2211			

Department of the Army

CDR FORSCOM ATTN: AFLG TRS FT MCPHERSON GA 30330-6000	1	CDR ARMY SAFETY CTR ATTN: CSSC PMG CSSC SPS FT RUCKER AL 36362-5363	1 1
CDR TRADOC ATTN: ATCD SL 5 INGALLS RD BLDG 163 FT MONROE VA 23651-5194	1	CDR ARMY ABERDEEN TEST CTR ATTN: STEAC EN STEAC LI STEAC AE STEAC AA APG MD 21005-5059	1 1 1 1
CDR ARMY ARMOR CTR ATTN: ATSB CD ML ATSB TSM T FT KNOX KY 40121-5000	1 1	CDR ARMY YPG ATTN: STEYP MT TL M YUMA AZ 85365-9130	1
CDR ARMY QM SCHOOL ATTN: ATSM PWD FT LEE VA 23001-5000	1	CDR ARMY CERL ATTN: CECER EN P O BOX 9005 CHAMPAIGN IL 61826-9005	1
CDR ARMY FIELD ARTY SCH ATTN: ATSF CD FT SILL OK 73503	1	DIR AMC FAST PROGRAM 10101 GRIDLEY RD STE 104 FT BELVOIR VA 22060-5818	1
CDR ARMY TRANS SCHOOL ATTN: ATSP CD MS FT EUSTIS VA 23604-5000	1	CDR I CORPS AND FT LEWIS ATTN: AFZH CSS FT LEWIS WA 98433-5000	1
CDR ARMY INF SCHOOL ATTN: ATSH CD ATSH AT FT BENNING GA 31905-5000	1 1	CDR RED RIVER ARMY DEPOT ATTN: SDSRR M SDSRR Q TEXARKANA TX 75501-5000	1 1
CDR ARMY AVIA CTR ATTN: ATZQ DOL M FT RUCKER AL 36362-5115	1	PS MAGAZINE DIV ATTN: AMXLS PS DIR LOGSA REDSTONE ARSENAL AL 35898-7466	1
CDR 6TH ID (L) ATTN: APUR LG M 1060 GAFFNEY RD FT WAINWRIGHT AK 99703	1		

Department of the Navy

OFC CHIEF NAVAL OPER ATTN: DR A ROBERTS (N420) 2000 NAVY PENTAGON WASHINGTON DC 20350-2000	1	CDR NAVAL AIR WARFARE CTR ATTN: CODE PE33 AJD P O BOX 7176 TRENTON NJ 08628-0176	1
---	---	--	---

CDR NAVAL SEA SYSTEMS CMD ATTN: SEA 03M3 2531 JEFFERSON DAVIS HWY ARLINGTON VA 22242-5160	1	CDR NAVAL PETROLEUM OFFICE 8725 JOHN J KINGMAN RD STE 3719 FT BELVOIR VA 22060-6224	1
CDR NAVAL SURFACE WARFARE CTR ATTN: CODE 63 CODE 632 CODE 859 3A LEGGETT CIRCLE ANNAPOLIS MD 21402-5067	1 1 1 1	CDR NAVAL AIR SYSTEMS CMD ATTN: AIR 4.4.5 (D MEARNS) 1421 JEFFERSON DAVIS HWY ARLINGTON VA 22243-5360	1
CDR NAVAL RSCH LABORATORY ATTN: CODE 6181 WASHINGTON DC 20375-5342	1		

Department of the Navy/U.S. Marine Corps

HQ USMC ATTN: LPP WASHINGTON DC 20380-0001	1	CDR BLOUNT ISLAND CMD ATTN: CODE 922/1 5880 CHANNEL VIEW BLVD JACKSONVILLE FL 32226-3404	1
PROG MGR COMBAT SER SPT MARINE CORPS SYS CMD 2033 BARNETT AVE STE 315 QUANTICO VA 22134-5080	1	CDR ATTN: CODE 837 814 RADFORD BLVD ALBANY GA 31704-1128	1
PROG MGR GROUND WEAPONS MARINE CORPS SYS CMD 2033 BARNETT AVE QUANTICO VA 22134-5080	1	CDR 2ND MARINE DIV PSC BOX 20090 CAMP LEJEUNNE NC 28542-0090	1
CDR MARINE CORPS SYS CMD ATTN: SSE 2030 BARNETT AVE STE 315 QUANTICO VA 22134-5010	1	CDR 1 FMFPAC G4 BOX 64118 CAMP H M SMITH HI 96861-4118	

Department of the Air Force

HQ USAF/LGSF ATTN: FUELS POLICY 1030 AIR FORCE PENTAGON WASHINGTON DC 20330-1030	1	SA ALC/SFT 1014 BILLY MITCHELL BLVD STE 1 KELLY AFB TX 78241-5603	1
HQ USAF/LGTV ATTN: VEH EQUIP/FACILITY 1030 AIR FORCE PENTAGON WASHINGTON DC 20330-1030	1	SA ALC/LDPG ATTN: D ELLIOTT 580 PERRIN BLDG 329 KELLY AFB TX 78241-6439	1

AIR FORCE WRIGHT LAB		WR ALC/LVRS	1
ATTN: WL/POS	1	225 OCMULGEE CT	
WL/POSF	1	ROBINS AFB	
1790 LOOP RD N		GA 31098-1647	
WRIGHT PATTERSON AFB			
OH 45433-7103			
AIR FORCE MEEP MGMT OFC	1		
OL ZC AFMC LSO/LOT PM			
201 BISCAYNE DR			
BLDG 613 STE 2			
ENGLIN AFB FL 32542-5303			

Other Federal Agencies

NASA		EPA	
LEWIS RESEARCH CENTER	1	AIR POLLUTION CONTROL	1
CLEVELAND OH 44135		2565 PLYMOUTH RD	
		ANN ARBOR MI 48105	
RAYMOND P. ANDERSON, PH.D., MANAGER	1	DOT	
FUELS & ENGINE TESTING		FAA	
BDM-OKLAHOMA, INC.		AWS 110	1
220 N. VIRGINIA		800 INDEPENDENCE AVE SW	
BARTLESVILLE OK 74003		WASHINGTON DC 20590	