

REPORT DOCUMENTATION PAGE

Form Approved
OMB No. 074-0188

Public reporting burden for this collection of information is estimated to average 1 hour per response, including the time for reviewing instructions, searching existing data sources, gathering and maintaining the data needed, and completing and reviewing this collection of information. Send comments regarding this burden estimate or any other aspect of this collection of information, including suggestions for reducing this burden to Washington Headquarters Services, Directorate for Information Operations and Reports, 1215 Jefferson Davis Highway, Suite 1204, Arlington, VA 22202-4302, and to the Office of Management and Budget, Paperwork Reduction Project (0704-0188), Washington, DC 20503

1. AGENCY USE ONLY (Leave blank)		2. REPORT DATE April 1994	3. REPORT TYPE AND DATES COVERED PhD. Thesis Dissertation, 1994	
4. TITLE AND SUBTITLE Abiotic and Biotic Reductive Dehalogenation of Halogenated Methanes			5. FUNDING NUMBERS N/A	
6. AUTHOR(S) Leah J. Matheson				
7. PERFORMING ORGANIZATION NAME(S) AND ADDRESS(ES) Oregon Graduate Institute of Science & Technology Portland, OR, 1994			8. PERFORMING ORGANIZATION REPORT NUMBER N/A	
9. SPONSORING / MONITORING AGENCY NAME(S) AND ADDRESS(ES) SERDP 901 North Stuart St. Suite 303 Arlington, VA 22203			10. SPONSORING / MONITORING AGENCY REPORT NUMBER N/A	
11. SUPPLEMENTARY NOTES Presented to the faculty of the Oregon Graduate Institute of Science & Technology in partial fulfillment of the requirements for the degree Doctor of Philosophy in Environmental Science and Engineering, April 1994. No copyright is asserted in the United States under Title 17, U.S. code. The U.S. Government has a royalty-free license to exercise all rights under the copyright claimed herein for Government purposes. All other rights are reserved by the copyright owner.				
12a. DISTRIBUTION / AVAILABILITY STATEMENT Approved for public release: distribution is unlimited			12b. DISTRIBUTION CODE A	
13. ABSTRACT (Maximum 200 Words) Reductive dehalogenation is an important reaction that generally leads to detoxification of many halogenated methanes. Halogenated methanes are widely used in industrial and commercial applications and the inadvertent or deliberate release of these chemicals has caused contamination of the atmosphere, soil and groundwater. The research presented here details the study of several systems for reductive dehalogenation of chlorinated methanes.				
14. SUBJECT TERMS reductive dehalogenation, halogenated methanes, SERDP, methanogens			15. NUMBER OF PAGES 138	
			16. PRICE CODE N/A	
17. SECURITY CLASSIFICATION OF REPORT unclass	18. SECURITY CLASSIFICATION OF THIS PAGE unclass	19. SECURITY CLASSIFICATION OF ABSTRACT unclass	20. LIMITATION OF ABSTRACT UL	

19980818 054

**ABIOTIC AND BIOTIC REDUCTIVE
DEHALOGENATION OF HALOGENATED
METHANES**

Leah J. Matheson
B.S., Washington State University, 1985

A dissertation presented to the faculty of the
Oregon Graduate Institute of Science & Technology
in partial fulfillment of the requirements for the degree
Doctor of Philosophy
in
Environmental Science and Engineering

April 1994

The dissertation "Abiotic and Biotic Reductive Dehalogenation of Halogenated Methanes" by Leah J. Matheson has been examined and approved by the following Examination Committee:

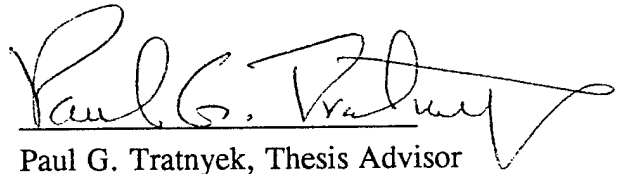

Paul G. Tratnyek, Thesis Advisor
Assistant Professor



David R. Boone
Professor



Richard L. Johnson
Associate Professor

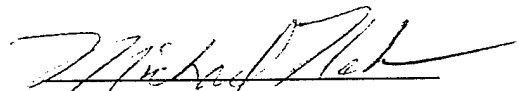

Michael J. K. Nelson
Manager of Environmental Technologies
EMCON Northwest, Inc.

Dedication

This thesis is dedicated to: my husband, Dale, who supported my decision to embark on this difficult undertaking (despite the sacrifices it meant to him) and stayed by me through the long and tumultuous process; and to my parents, Val and Kathie, who have always supported my endeavors (no matter how crazy) and instilled in me the desire to learn.

Acknowledgments

I would like to thank all of the members of my dissertation committee for their guidance and efforts on my behalf. I am grateful for their contributions to my education and professional development. A special thanks goes to my thesis advisor, Dr. Paul Tratnyek, for his patience and guidance. I owe a lot of my future plans to his faith in me as a scientist. I would also like to thank Dr. Michael Nelson for his mentorship and friendship. I don't know if I could have started, or finished, this venture without his encouragement, wit and wisdom!

It would be impossible to acknowledge all of the people who have helped me throughout my years at OGI, so I say "thank you" to everyone. I hope that I have been able to express my gratitude to all of you personally and let you know that I am truly grateful for your help and friendship.

Table of Contents

Dedication.....	iii
Acknowledgments	iv
Table of Contents	v
List of Tables.....	vii
List of Figures.....	viii
Abstract	xii
Chapter 1 - General Introduction	1
Halogenated Methanes in the Environment	2
Human Health Risks of Halogenated Methanes	4
Dehalogenation Reactions.....	5
Scope of this work	6
Chapter 2 - Microbiological Reductive Dechlorination of Chlorinated Methanes	10
Abstract.....	11
Introduction	12
Experimental.....	15
Results and Discussion	18
Conclusions	20
Chapter 3 - Reductive Dehalogenation of Chlorinated Methanes by Immobilized Cobalamins	26
Abstract.....	27
Introduction	28
Experimental.....	31
Results and Discussion	34
Conclusions and Practical Applications.....	41

Chapter 4 - Reductive Dehalogenation of Chlorinated Methanes by Iron Metal.....	51
Abstract.....	52
Introduction	53
Chemical Background	55
Experimental.....	58
Results and Discussion	61
Conclusion	70
 Chapter 5 - Microbial and Geochemical Processes Affecting Reductive Dehalogenation by Iron Metal in the Environment	 81
Abstract.....	82
Introduction	83
Experimental.....	89
Results and Discussion	94
Conclusions	99
 References	 108
 Vitae	 125

List of Tables

Table 1.1 Production Levels and Uses of Selected Halogenated Methanes.	8
Table 3.1 Initial conditions for dechlorination experiments.	43
Table 3.2 Kinetics of carbon tetrachloride disappearance.	44
Table 4.1 Kinetics of Carbon Tetrachloride Disappearance.	71
Table 4.2 Effects of Treatments on the Rate of Reductive Dehalogenation for Carbon Tetrachloride.	72
Table 4.3 Kinetics of Carbon Tetrachloride Disappearance in Buffered Systems.	73
Table 4.4 Effects of Iron Loading on the Rate of Reductive Dehalogenation for Carbon Tetrachloride.	74
Table 5.1 CNS Analysis of Bulk Composition of Iron Barrier Material.	100
Table 5.2 Enrichment Results for the July 13, 1993 Cores.	101

List of Figures

- Figure 1.1** Possible dehalogenation reaction pathways. X = halogen substituent, R = unspecified functional group. 9
- Figure 2.1** Scheme showing possible mechanism of reductive dechlorination by methanogens, proposed by Fathepure and Boyd [45] for the pathway of tetrachloroethylene reductive dechlorination by methanogens. Electrons may be transferred to the halogenated substrate via an electron carrier (X) involved in methanogenesis. 22
- Figure 2.2** Schematic depicting the gas-tight culture vessel. A 1-L Pyrex bottle was connected, via swagelock fittings, to a valve with snap closure for use with volatile halocarbons in biotic dehalogenation experiments. 23
- Figure 2.3** Results showing that a minimum inhibitory concentration was not obtained for two pure cultures of *Methanosarcina* in serum bottle experiments. A slight decrease in specific growth rate of *Methanosarcina mazei* S-6 (closed squares) and *Methanosarcina barkeri* 227 (open squares) was observed with exposure to increasing concentrations of methylene chloride. Cultures were grown on 50 mM methanol at 37 °C. 24
- Figure 2.4** Complete inhibition of *Methanosarcina mazei* S-6 by 100 µM methylene chloride added after 72 hr of growth on 100 mM acetate (open squares). Closed squares represent an identical culture that did not receive methylene chloride. 25
- Figure 3.1** Scheme showing proposed pathways for the reduction of organic substrates involving an electron-transfer "mediator". Possible electron donors in the environment include microorganisms, organic matter, and minerals. Probable mediators are porphyrins, corrinoids, flavins, quinones, and enzymes.

Substrate examples include halogenated hydrocarbons and nitro aromatics. This figure illustrates the role of the mediator, which is responsible for the accepting electrons from a donor and transferring them to an oxidized organic substrate. The mediator is cycled between reduced and oxidized states. Similar figures can be found in literature, including Glass [53], Esaac and Matsumura [44], Schwarzenbach et al. [119] and Kobayashi and Rittman [71]. 45

Figure 3.2 Disappearance of carbon tetrachloride with appearance of corresponding sequential dehalogenation products in a system containing 46 nmol cyanocobalamin, 27 μmol Ti(III)citrate, and 2.2 μmol carbon tetrachloride at pH 7, 25°C. Compounds were measured in the gas phase and total concentrations calculated using Henry's Law constants. Graphed values represent total concentrations and regression lines correspond to equations 1-5. 46

Figure 3.3 First-order disappearance plot for dechlorination of methylene chloride by reduced cyanocobalamin. Experiment: 46 nmol cyanocobalamin, 27 μmol Ti(III)citrate, and 13 μmol methylene chloride, at 25 °C, pH 7. 47

Figure 3.4 Carbon tetrachloride is sequentially reduced by (dicyano)cobalamin immobilized on EA-Sepharose in the presence of a reductant. Cyanocobalamin, 0.64 μmol ; Ti(III)citrate, 27 μmol ; Sepharose, 0.3 g (dry wt.); pH 7; 25°C 48

Figure 3.5 Variation of the amount of cyanocobalamin immobilized on talc with variation of pH. Buffers used are described in text. Immobilizations were performed in foil-covered serum bottles incubated on a platform shaker at 20 °C for 24 hr. 49

Figure 3.6 First-order disappearance plot for carbon tetrachloride in the presence of reduced cyanocobalamin immobilized on talc. Cyanocobalamin, 0.046 μmol ; Ti(III)citrate, 66 μmol ; 2 g talc; pH 7; incubated at 25 °C on a platform shaker. Closed triangles = dechlorination by reduced, unbound cyanocobalamin; closed squares = dechlorination by reduced, talc-bound cyanocobalamin; open squares = dechlorination by recycled talc-bound cyanocobalamin 50

Figure 4.1 Pourbaix diagram for the Fe-H ₂ O system under conditions typical of this study: Fe _T = 0.076 mM, {Cl ⁻ } = 0.001, and 15 °C. Lines for halomethane redox couples are based on potentials in [141]	75
Figure 4.2 Scheme showing proposed pathways for reductive dehalogenation in anoxic Fe-H ₂ O systems: A) direct electron transfer from iron at the metal surface; B) reduction by Fe ²⁺ , which results from corrosion of the metal; C) catalyzed hydrogenolysis by the H ₂ that is formed by reduction of H ₂ O during anaerobic corrosion. Stoichiometries are not shown	76
Figure 4.3 Disappearance of a) carbon tetrachloride with the appearance of chloroform, and b) subsequent disappearance of chloroform with appearance of methylene chloride. System: 1 g of iron, unbuffered pH 8.0, and 15 °C	77
Figure 4.4 The effect of pH on the pseudo-first-order rate constant for carbon tetrachloride dehalogenation by iron. Good's buffers were used. Each bottle contained 1 gram Fisher iron powder, was mixed at 15 rpm and incubated at 15 °C. Regression line corresponds to eq 13	78
Figure 4.5 The effect of surface area on pseudo-first-order rate constants for carbon tetrachloride dehalogenation. Iron loadings varied, as shown in Table 4.4. The systems were unbuffered mixed at 15 rpm and incubated at 15 °C. Regression line corresponds to eq 14. Solid circles are the fitted data, open circles are data collected in a subsequent experiment to validate the results with respect to variation in reaction volume	79
Figure 4.6 The effect of mixing rate on pseudo-first-order rate constant for carbon tetrachloride dehalogenation by iron. All contained 1 g Fisher iron powder, were unbuffered, and incubated at 15 °C	80
Figure 5.1 Schematic showing general corrosion processes at the Fe surface	102
Figure 5.2 Schematic showing hypothetical domains of influence for microbial activity in a site containing a zone of buried Fe	103

Figure 5.3 Schematic of the buried Fe barrier showing the location of the core samples. A) Side View; B) Plan view 104

Figure 5.4 Illustration of the core sample extruder. Core is held in place while a piston is advanced through the core tube, paring $\frac{1}{4}$ in from the outer surface of the core, and extruding the contents in a continuous sample. Extruder designed by C. Palmer (Oregon Graduate Institute of Science and Technology)..... 105

Figure 5.5 Dechlorination of carbon tetrachloride with acetone- and HCl-cleaned unburied Fe filings (Kanmet Castings, Ontario, Canada). HCl-treated (squares) and acetone-treated (circles) Fe was exposed for 1 hr in each treatment and rinsed before use in the anaerobic batch experiment. Carbon tetrachloride initial concentrations were approximately 100 μ M. Incubation at 15 rpm 15 °C..... 106

Figure 5.6 Effect of a bacterial inoculum on dechlorination of carbon tetrachloride by laboratory batch systems. Triangles = autoclaved, inoculated samples; squares = unautoclaved, uninoculated controls; circles = autoclaved, uninoculated controls. Approximately 2×10^7 cells/mL were added to the bottles one hour prior to addition of 100 μ M carbon tetrachloride. Bottles were incubated at 25 °C and at 15 °C on rotary shakers at 15 rpm. The general experimental procedure is described in Chapter 4 107

Abstract

Reductive dehalogenation is an important reaction that generally leads to detoxification of many halogenated methanes. Halogenated methanes are widely used in industrial and commercial applications and the inadvertent or deliberate release of these chemicals has caused contamination of the atmosphere, soil and groundwater. The research presented here details the study of several systems for reductive dehalogenation of chlorinated methanes.

The first system described in this dissertation involves reductive dechlorination of chlorinated methanes by laboratory cultures of methanogens. A vessel was constructed that allowed maintenance of anaerobic conditions and minimized losses of the volatile chlorocarbons. Methylene chloride was not dechlorinated in the presence of pure cultures of methanogens. Similarly, dechlorination did not occur in enrichments made with samples from several different anaerobic digesters.

Abiotic dehalogenation studies showed that cobalamins, cobalt-centered macrocyclic compounds, catalyzed the reductive dechlorination of several halomethanes in anaerobic, closed batch systems. These studies focused on immobilization of cobalamins to several types of supports for use in pollution remediation strategies. Cyanocobalamin bound to Epoxy-Activated Sepharose 6B and talc catalyzed the rapid reduction of carbon tetrachloride and methylene chloride to sequentially reduced products.

Corroding iron metal was also studied as a reductant for halogenated methanes. Several chlorinated methanes were reductively dechlorinated in closed, anaerobic, laboratory-scale model systems containing granular iron. Carbon tetrachloride was sequentially dehalogenated, via chloroform, to methylene chloride. The initial rate of each reaction was pseudo-first order in substrate and declined substantially with each dehalogenation step. Trichloroethene was also dechlorinated by iron, although more slowly than carbon tetrachloride. The reaction of chlorinated methanes appears to involve a direct interaction between the substrate and the iron surface. When surface condition is constant, the rate of reaction is roughly first-order in iron surface area and the rate increases markedly with increasing iron surface area.

Studies were also performed to determine the effects of microbial and geochemical processes that developed during a field demonstration in which iron metal had been buried in the path of a chlorinated-solvent contaminated plume. Two sets of cores were obtained and examined for microbial and geochemical developments one, and two, years after burial of the iron.

Chapter 1

General Introduction

Halogenated Methanes in the Environment

Halogenated methanes (or halomethanes) are organic compounds containing one carbon with only halogen and hydrogen substituents. Environmentally significant halomethanes typically contain halogen substituents of chloride, fluoride, and bromide. Table 1.1 lists examples of these compounds and their commercial and industrial uses. The chlorinated methanes as a class are very stable, low-boiling, non-polar compounds that are useful as solvents, industrial intermediates, preservatives and pesticides. Chlorofluoromethanes have particularly low boiling points, are highly stable and have significant heat capacities. These properties make the chlorofluorocarbons ideal thermal transfer agents for use in refrigerants and cooling systems. They have also been used as propellants for aerosols. Some of the halomethanes are found naturally in the environment, especially chloromethane [110]. However, due to contamination from human sources most of these compounds can be found in the environment at levels far greater than would exist naturally.

Large-scale commercial production of the halomethanes began about 30 to 50 years ago, and many are still widely produced today (Table 1.1). In the 1970's, public concern about the destruction of atmospheric ozone and the pollution of many drinking water supplies by these compounds forced the shift towards development of safer compounds and disposal practices. Atmospheric contamination by some chlorine-containing compounds leads to the destruction of the ozone layer that shields the earth's inhabitants from harmful solar radiation. Concerns about the harmful effects of ozone depletion to human health has led countries worldwide to mandate that production of chlorofluorocarbons cease by the end of 1995 [155]. Recently, all uses of chlorinated compounds in industrial and commercial processes has received heightened scrutiny from the public due to the increasing evidence of carcinogenicity and other deleterious health effects of these compounds [59]. This has led many industries to consider non-chlorinated alternatives, even where effects on atmospheric ozone are not a concern. One such process receiving scrutiny is the disinfection of drinking water by

chlorination, which has been shown to produce low levels of halomethanes by the reaction of chlorine with dissolved organic matter [10, 30].

Groundwater contamination by halogenated methanes is widespread due to the high degree of commercial and industrial usage of these chemicals [105]. Table 1.1 lists the production amounts and uses of some halomethanes. Halogenated methanes can reach the groundwater zone via leakage of storage tanks and distribution pipelines, spillage during loading and off-loading of chemical containers, leaking drums of disposed wastes, and intentional spillage. The latter has occurred due to the belief that the low boiling points of these compounds would allow them to completely volatilize to the atmosphere. Unfortunately, several other physical characteristics of the chlorinated aliphatics were overlooked, causing the introduction of chlorocarbon compounds into the groundwater [105]. One such factor is the volatilization of the chlorinated compound downward, as well as upward, resulting in the dissolution of the compound into water percolating through the subsurface. Also, many chlorinated methanes possess low viscosities and densities greater than water, allowing the compound to move downward through a soil column at relatively rapid rates. Once these compounds reach the aquifer they settle to the bottom and dissolve at relatively slow rates. Even though the solubilities of chlorinated methanes are low, they are high enough to cause contamination of the groundwater that exceeds permissible levels.

Human Health Risks of Halogenated Methanes

While the human health effects of polluting our environment with halomethanes may be indirect, as in the case of ozone depletion by chlorofluoromethanes, halomethanes also have direct toxicological effects in humans. Most of the halogenated methanes are moderately to highly toxic in acute exposure situations. As a group, the halogenated methanes have narcotic properties at high dose levels and can cause injury to the central nervous system, lungs, liver, and kidneys [3, 33]. For example, carbon tetrachloride has caused death to humans following acute exposure via inhalation and ingestion (200-400 mg/L) [3]. Chronic exposure can cause minor effects that depend on the mode of entry into the body, dose and duration of exposure. Chronic exposure to carbon tetrachloride has resulted in varying degrees of pulmonary edema, liver and kidney damage, and neurological effects. In cases where the exposure was light, many of these effects were not permanent. However, chronic exposure to halomethanes may cause cancer in humans. The human carcinogenicity of these compounds has not been directly shown but both carbon tetrachloride and chloroform produced tumors in test animals after various routes of administration, and chloromethane was mutagenic to *Salmonella typhimurium* strain TA 1538 [46].

An interesting note to the pathology of carbon tetrachloride is that injury to the liver results from homolytic cleavage of the carbon-chlorine bond by enzymes and cofactors, producing highly reactive free radical intermediates [46]. The free radicals produced may initiate the decomposition of lipids. This evidence of the reactivity of halomethanes with enzymes and cofactors in mammalian systems from a toxicological perspective provides important information for the environmental dehalogenation reactions studied in Chapter 3.

Dehalogenation Reactions

There are several general reaction types available for cleaving the carbon-halogen bonds that characterize many environmental contaminants (Figure 1.1). These include nucleophilic substitution; β -elimination of HX (dehydrohalogenation); gem-elimination; reductive elimination (vicinal dehalogenation); reductive dehalogenation (hydrogenolysis); and oxidation [78, 142, 144]. The first three processes do not change the oxidation state of the molecule, while reduction and oxidation reactions require external electron donors and acceptors. Substitution reactions replace the halogen substituent with a nucleophile such as hydroxide (hydrolysis), sulfide, or thiols. Dehydrohalogenation results from the removal of a halogen substituent with E2-type elimination (dehydrohalogenation) yielding HX, or E1 elimination yielding products via carbene intermediates. Reductive dehalogenation occurs by the addition of electrons to reduce a single C-X bond to a C-H bond, while reductive elimination reduces compounds containing two or more carbon atoms to unsaturated products. Oxidative dehalogenation results in the formation of carbonyl products. The relative rates of these processes will vary with substrate, and chemical and microbiological conditions. Halogenated methanes are not subject to dehydrohalogenation or vicinal dehalogenation, and reaction of these compounds with environmentally relevant nucleophiles is very slow under most conditions [68, 72]. *Gem*-elimination of halogenated methanes requires the presence of a strong base and has not been observed in environmental systems, but may occur in biological systems during dehalogenation by transition-metal cofactors [144]. Reduction of halogenated methanes is more likely than oxidation due to the relatively oxidized state of most halomethanes [141].

Scope of this work

The sequence of the chapters in this dissertation reflects the evolution of my research over time. Originally, my concern was the metabolism of halogenated hydrocarbons by anaerobic bacteria. Halogenated methanes were chosen because of their potential for formation during the chlorination of drinking water, presence at many contaminated sites, and similarity to the "greenhouse" gases or chlorofluorocarbons. I began my research by trying to enrich for methanogens that were able to metabolize halogenated methanes, primarily methylene chloride. Chapter 2 details those studies.

Methanogens also produce large amounts of metal-centered coenzymes and cofactors. The ability of these metallomacrocycles to mediate reduction of organic substrates had recently been demonstrated *in vitro* with various chlorinated hydrocarbons. These reports led me to replace my "whole-cell" studies with model systems based on the cobalt-centered corrinoid, cyanocobalamin (vitamin B₁₂). Cyanocobalamin is one of many metal-centered macrocyclic compounds that are capable of transferring electrons from a donor to an oxidized substrate. These biologically produced compounds also catalyze the reduction of several environmental pollutants, including halogenated hydrocarbons and nitroaromatics. Immobilization of these metallomacrocycles on solid supports takes advantage of their catalytic nature, as long as the reducing activity of the compound is not lost during binding. This work reports the reductive dehalogenation of chlorinated methanes by cyanocobalamin immobilized on EA-Sepharose and talc. The use of talc explores the effectiveness of a relatively cheap material for immobilization, and the possibility that bacterial coenzymes are immobilized by geologic materials common in the natural environment. The dehalogenation studies by immobilized metallomacrocycles are detailed in Chapter 3.

It soon became apparent that enhancement of *in situ* dechlorination by iron-metal was not possible without a clear understanding of how iron and solvents interact in water-saturated porous media. At the time, this understanding was not available on

the mechanism of dechlorination by iron. To determine the mechanism and kinetics of these dechlorination reactions with chlorinated methanes, experiments were performed with laboratory batch systems under anaerobic conditions. Chapter 4 records the results of this work and is based on a manuscript that has been submitted to *Environmental Science and Technology*.

Microbial and geochemical processes will certainly affect the dehalogenation of halomethanes by buried iron. To study the effect of these processes on the iron zone at the field site, cores were obtained from Stephanie O'Hannesin (University of Waterloo) after one and two years of operation. The core samples were subjected to microbiological, chemical and surface analysis. Another important goal for the study of the site was to verify that the observations in the laboratory-scale batch experiments were representative of what could be expected at the field site. Dehalogenation experiments with the core material were carried out in the anaerobic laboratory batch systems. The results of these studies are presented in Chapter 5.

Although the work presented in this dissertation encompasses a broad range of subjects, the common theme is the study of reductive dehalogenation reactions relating to the remediation of halomethane-contaminated environments. Because of the large scope of this work, some of the subjects did not receive as exhaustive a study as the author would have liked. However, all subjects are presented with a thorough literature review introducing the problem, details of the experimental procedures, conclusions and practical applications. The title page of each section lists the primary advisors to the author for that part of the work.

Table 1.1 Production Levels and Uses of Selected Halogenated Methanes.

Compound Name, Formula	Uses^a	World Production (x10⁶ lb.)
Carbon Tetrachloride, CCl ₄	Chlorofluorocarbon production; Fumigant; Fire retardant; Degreaser; Organic syntheses; Hookworm treatment in cattle	627 ^b
Chloroform, CHCl ₃	Extractant and industrial solvent; Pharmaceutical production; Heat-transfer medium; Fire retardant; Fumigant; Anesthetic	422 ^b
Methylene Chloride, CH ₂ Cl ₂	Degreaser; Paint stripper; Production of acetate fibers and films, pharmaceuticals; Aerosols	561 ^b
Methyl Chloride, CH ₃ Cl	Production of silicones, tetramethyl lead, butyl rubber, and methyl cellulose; Herbicide	180 ^c
FREON-11, CFCl ₃	Refrigerant, propellant, aerosols	266 ^d
FREON-12, CF ₂ Cl ₂	Refrigerant, propellant, aerosols	390 ^d

^a [1, 2, 40, 46]

^b 1986 [105]

^c 1980 [41]

^d 1975 [33]

Nucleophilic Substitution *β -Elimination (Dehydrohalogenation)**Gem-Elimination**Reductive Elimination (Vicinal Dehalogenation)**Reductive Dehalogenation**Reductive Coupling*

Figure 1.1 Possible dehalogenation reaction pathways. X = halogen substituent, R = unspecified functional group.

Chapter 2

Microbiological Reductive Dechlorination of Chlorinated Methanes

Leah J. Matheson, Richard L. Johnson, and David R. Boone

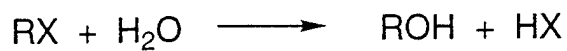
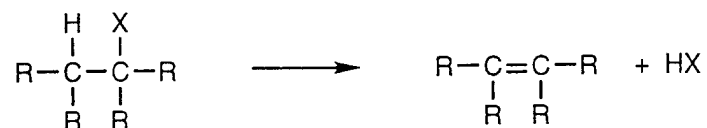
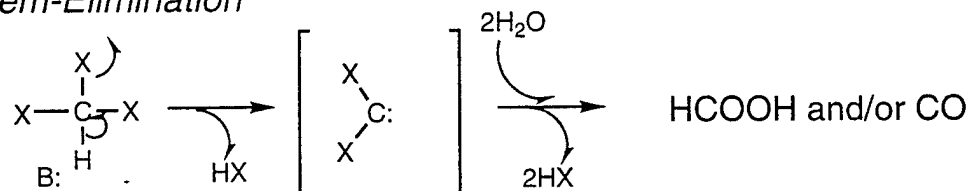
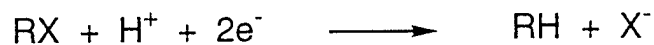
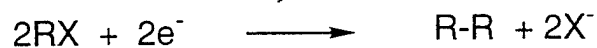
Abstract

Anaerobic batch systems and a specially-designed, anaerobic, gas-tight culture vessel were used to test two strains of methanogens, *Methanosarcina mazeii* S-6 and *Methanosarcina barkeri* 227, for their ability to dechlorinate methylene chloride. Dechlorination, cometabolic or metabolic, was not observed with either strain. A methylene chloride concentration of 100 μM completely inhibited methanogenesis from *M. barkeri* 227 in a gas-tight culture vessel. However, experiments performed in serum bottles with butyl-rubber stoppers did not show significant inhibition at this concentration. The difference between these systems was shown to be due to the diffusion of the chlorinated compound into the stopper. Enrichment cultures inoculated with several different samples of anaerobically digested wastes were also studied for dechlorinating ability. All enrichment studies were carried out in serum bottles. Dechlorination of methylene chloride as a cometabolite, or sole source of carbon and energy, was not observed in these systems.

Introduction

Methanogens. Methanogens are a diverse group of strictly anaerobic bacteria that produce methane as an end product of their catabolic activity. These bacteria belong to the kingdom *Archaeobacteria*, and have evolved over a period of time from early in the beginning of life on earth [18]. The habitats occupied by methanogens are those where electron acceptors such as oxygen, nitrate, sulfate, and ferric iron are not in abundant supply. Methanogens are commonly found in anaerobic digesters, sewage sludge, anoxic sediments, flooded soils, and gastrointestinal tracts of ruminants and termites. In these environments, methanogens catabolize the primary and secondary products of carbon metabolism of other microorganisms, such as acetate, carbon dioxide and hydrogen. Pure cultures of methanogens metabolize acetate, formate, methanol, the methyl groups of amines, sulfides and selenides, hydrogen plus carbon dioxide, and hydrogen plus some alcohols [18]. In general, the biochemistry of methanogenesis from these compounds involves a number of coenzymes and cofactors, most of which are found only in methanogens, that accomplish methyl-group transfer and electron transfer reactions [36].

Reductive Dehalogenation by Methanogens. Methanogens are able to reductively dehalogenate halogenated methanes as a gratuitous metabolism (cometabolism) [80, 144]. However, the metabolism of halomethanes as a source of carbon and/or energy has not been indisputably shown in methanogens. Even though metabolism of halomethanes by these bacteria has not been shown, these bacteria may be able to metabolize halogenated methanes by the inadvertent involvement of these compounds in the methanogenic process due to the apparent structural similarities between halomethanes and the C1 substrates metabolized by methanogens. Specifically, the similarity of halogenated methanes to the methyl group carried on coenzyme M (CoM) may allow their fortuitous reduction by methyl-CoM methyl reductase. Methyl-CoM methyl reductase is a multienzyme complex that contains F₄₂₀ (a flavin analog)

and F₄₃₀ (a nickel-centered porphyrin), in addition to other proteins and coenzymes [36, 116]. Reductive dechlorination of chlorinated alkanes and alkenes occurs in the presence of reduced F₄₃₀ in model systems [48, 73]. A general scheme for reductive dechlorination coupled to methanogenesis is shown in Figure 2.1, in which the halogenated compound becomes fortuitously reduced by an unknown electron carrier involved in the methanogenic pathway [45]. Whether the enzyme systems of methanogens can actually catabolize chlorinated methanes, rather than cometabolize them, cannot be determined by structural similarities to catabolic substrates alone.

Over the period of time since the experiments reported here, several studies have been published that report cometabolic dehalogenation of chlorinated methanes by methanogens in pure and mixed cultures [42, 74, 81, 96, 138]. Recently, strains of *Methanosarcina* growing on methanol or acetate were reported to dechlorinate chloroform [96]. The major products were identified as methylene chloride, chloromethane and carbon dioxide, indicating that reductive dehalogenation was not entirely responsible for the reaction. Egli and coworkers [42] observed that pure cultures of *Methanobacterium thermoautotrophicum* were able to dechlorinate carbon tetrachloride at similar rates to those of autoclaved cultures. This suggests the involvement of a heat-stable cofactor. Dehalogenation by live cultures resulted in reductively dechlorinated products and carbon dioxide, indicating that more than one mechanism was responsible for the dehalogenation reaction. Carbon dioxide may be formed by the oxidation and hydrolysis of a trichloromethyl radical intermediate, formed from the one-electron reduction of a halogenated methane; or by complete hydrolysis of the halomethane [32]. In a similar experiment with the chlorofluorocarbon, FREON-11 (CFCl₃), reductive dechlorination was not the only mechanism observed [74]. CFCl₃ was transformed to CHFCl₂, fluorine and carbon monoxide, in the presence of hydrogen, by suspensions of *Methanosarcina barkeri* (strain Fusaro) grown on methanol. These authors postulated a corrinoid-mediated mechanism that produces a dihalocarbene intermediate that is rapidly hydrolyzed to carbon monoxide, fluoride and chloride. Freedman and Gossett [47] observed growth of a methanogenic enrichment culture on methylene chloride, forming carbon dioxide and methane. However, evidence suggested that non-methanogens such as acetogens and methylene chloride-oxidizing bacteria were responsible for the dechlorination reactions. Acetoclastic and carbon dioxide-reducing methanogens merely utilized the acetate and carbon dioxide that were produced. Finally, an additional study [138] observed methyl chloride metabolism by an unknown anaerobic microorganism that

appears to be an acetogen, and no methanogens have been isolated that are capable of methyl chloride catabolism.

This review shows that even up to the present date little evidence has been presented to show metabolism of halomethanes by methanogenic bacteria. The initial goal of the research presented here was to demonstrate the use of selected halomethanes as sole sources of carbon and energy for methanogens. Two species of methanogens, *Methanosarcina mazeii* S-6 and *Methanosarcina barkeri* 227, were tested for their ability to metabolize methylene chloride. Experiments were also performed with several enrichment cultures inoculated with methanogenic mixed cultures grown in anaerobic sludge digesters on a variety of different wastes.

Experimental

Halogenated Methanes. Chlorinated solvents were obtained in high purity and used without further purification. These included carbon tetrachloride, HPLC grade (Aldrich); chloroform, LC grade, preserved with 1% (v/v) ethanol (Burdick & Jackson); methylene chloride, 99+%, anhydrous (Aldrich); and chloromethane, 99.5+% (Aldrich). Saturated aqueous stock solutions of these halocarbons were prepared by allowing roughly 1 mL of organic phase to equilibrate with 40 mL of deionized water (NANOpure, 18 M Ω -cm) in glass vials capped with Teflon Mininert valves. Aqueous standard solutions were made by diluting the saturated stock solutions with deionized water. Gaseous standards were made by placing the appropriate amount of compound in a 0.8 L steel canister with a snap valve and pressurizing to 5 atm with nitrogen.

Gas-Tight Culture Vessel. A gas-tight culture vessel was developed to maintain anaerobic conditions and prevent losses of halocarbons during the experiments with methanogens (Figure 2.2). The stoppers that are normally used in the culture of methanogens are impermeable to oxygen but adsorb the chlorinated methanes used in this study. The new, gas-tight culture vessel is both impermeable to oxygen and inert to halomethanes. The vessel consists of a 1 L glass bottle with 2.5-cm long and 1.27-cm diameter precision glass tubing as its sole opening. The tubing is connected to a stainless steel snap-valve assembly (Nupro) with a Teflon™ ferrule. No losses due to adsorption to the ferrule were detected. The stainless steel snap valve was resistant to solvent attack and allowed aseptic and anoxic sampling of the gas and liquid phases with negligible loss of volatile compounds.

Culture Conditions. Two strains of methanogens were used for dehalogenation studies, *Methanosarcina barkeri* 227 and *Methanosarcina mazeii* S-6. A basal salts

medium [153], pH 6.5-7, was inoculated with the appropriate organism. Organisms were grown on 20 to 50 mM acetate or methanol. The cultures were incubated at 37°C, without shaking, in the dark. Growth was measured by methane production. Methane concentrations were determined by removing a 10 μ L gas sample from the headspace of the culture vessel and analyzing for methane by gas chromatography with a 2 m x 4 mm ID column packed with activated charcoal and quantification by FID. The growth substrate was omitted in experiments that screened for metabolic activity on halogenated substrates. Some of the dehalogenation studies used an anaerobically digested sewage sludge from the Rock Creek Treatment Plant of the Unified Sewerage Agency (Hillsboro, Oregon) as an inoculum. Also tested were cherry-waste digester sludge from a digester that had been operating anaerobically, an acetogenic bacterium isolated by Shiusong Ni (personal communication), and sludge from a propionate-fed anaerobic digester that had been operating for two months.

Determination of Inhibition by Chlorinated Methanes. Two strains of *Methanosarcina* strains were screened for the minimum concentration of methylene chloride that would inhibit growth. The effect of various concentrations on the specific growth rates of the organisms were observed after addition of an aliquot of the compound at mid-log phase growth. These values were to be used to determine the concentrations of halomethane added in dehalogenation studies.

Dechlorination Studies. Dechlorination studies were carried out in both the gas-tight culture vessel and serum bottles with butyl rubber and Hycar (Pierce) septa. The typical length of exposure of the *Methanosarcina* was 14 days. The cometabolic sewage sludge enrichments were carried out for 273 days, and the sole-source enrichments were monitored for 244 days. Methylene chloride was used in all experiments with concentrations ranging from 10-500 μ M. Chlorinated hydrocarbon concentrations were monitored by sampling the gas phase of cultures equilibrated at 25 °C in a water bath. The gas phase was sampled in the following manner: A 400 μ L sample chamber was fitted with a luer tip on one end, and hooked to a multiport valve (Carle) at the other end. The luer tip could attach to the culture vessel, or a disposable needle to pierce serum bottle septa. The valve could connect the other end of this loop to either a vacuum pump, cap, or GC carrier gas flow (4 mL/min He). When the

no equilibrium with lab pressure, or loss of compound, occurred. These samples were analyzed by GC (HP5890A, Hewlett-Packard) with a 30 m x 0.53 mm ID glass capillary column, 5% phenyl- 95% methylsilicone phase (Supelco) in an oven heated to 100 °C. Satisfactory results were obtained with FID detection. Gas phase concentrations were used to determine the total concentrations using Henry's Law constants at the appropriate temperature and pH [55]. Serum bottles were inverted to minimize diffusion of halomethane into the stopper, and returned to the incubator. Chlorinated substrates and products were determined by comparison of retention times with standard compounds.

Results and Discussion

Minimum Inhibitory Concentrations. *Methanosarcina mazeii* S-6 and *Methanosarcina barkeri* 227 were only slightly inhibited by high doses of methylene chloride (200-600 μ M) in initial minimum inhibitory concentration studies. Figure 2.3 shows that the growth rate declined with increasing methylene chloride concentration although no concentration was observed that completely inhibited methanogenesis. These initial studies were performed in serum bottles with butyl rubber septa due to the unavailability of other septa or the gas tight culture vessel. A high rate of methylene chloride loss was experienced with these septa, 20-50% in 24 hr, suggesting that the organisms were not exposed to the full amount of methylene chloride added in the initial experiments. Also, the methylene chloride-spiked cultures continued log-phase growth and did not reach stationary-phase, probably due to the slow dissipation of the methylene chloride. The above interpretation of the results in Figure 2.3 were verified when the gas tight culture vessel was used in subsequent experiments with methylene chloride. The total inhibition of *M. mazeii* S-6 immediately after the addition of 100 μ M methylene chloride is shown in Figure 2.4. Methylene chloride was added at the same point of the growth curve, and in the same manner, as in previous experiments. This was the only concentration of methylene chloride tested in the gas tight culture vessel, and no other chlorinated methanes were tested. An attempt was made to use valve-fitted 800 mL stainless steel canisters for the minimum inhibitory concentration experiments. These canisters proved to be unsuitable for these experiments due to leakage of large amounts of methylene chloride from these cans, and the entry of oxygen that inhibited the cultures. It was also difficult to maintain pure cultures in these vessels, possibly due to contamination during the sampling procedure.

Dehalogenation Studies. Initial dehalogenation studies were performed in serum bottles with butyl rubber septa despite the problem of maintaining a constant methylene chloride exposure. Neither of the *Methanosarcina* strains dehalogenated

methylene chloride during the time frames observed in this study. This conclusion is based on the lack of dechlorination products and that losses of chlorocarbon in live cultures were similar to those in controls containing chlorinated substrate only. Subsequent enrichments were made in serum bottles with Hycar. A decline in methylene chloride concentration of 10-30% in all samples including the controls was observed in the Hycar stoppered systems. Dehalogenating activity was not observed whether methylene chloride was the sole form of hydrocarbon present, or as a secondary substrate. This was also true for all digester sludge enrichments and the acetogenic culture. Methane production in enrichments with methylene chloride was similar to those without, indicating that no inhibition of these microorganisms was occurring. The loss of methylene chloride to the stoppers of the serum bottles experiments may have contributed to inability of these enrichments to cause reductive dechlorination because of the incomplete exposure to the chlorinated hydrocarbon.

Conclusions

While no dechlorination of methylene chloride was observed in these studies with pure cultures of methanogens or methanogenic enrichment cultures, these results do not suggest that dechlorination is not possible in these systems. As illustrated in the introductory discussion, dechlorination of halogenated methanes has been observed in several methanogenic systems [42, 47, 74, 96, 131]. In these most of these studies the more highly chlorinated methanes than methylene chloride were used. Due to the fact that these compounds are more oxidized relative to methylene chloride, and other as yet unknown factors, the dechlorination of more highly chlorinated methanes is generally favored in reducing systems [141]. To the author's knowledge metabolism of methylene chloride by pure cultures of methanogens has not been reported. However, two studies observed the dechlorination of methylene chloride in mixed methanogenic cultures [47, 131]. Freedman and Gossett [47] observed the transformation of methylene chloride to carbon dioxide and methane in a methanogenic enrichment culture that contained a complex population of both methanogens and non-methanogens. The results of this experiment suggest a specific relationship between the various organisms to transform the halogenated methane, including interspecies hydrogen transfer between methylene chloride-oxidizing bacteria and carbon dioxide-reducing methanogens and production of acetate from methylene chloride by non-methanogens. The methanogens do not appear to be directly responsible for dechlorination reactions in the proposed scheme, rather the carbon dioxide-reducing and acetoclastic methanogens metabolize the products of methylene chloride transformation by acetogens and methylene chloride oxidizing bacteria. Similarly, Stromeyer et al. [131] observed that the transformation of methylene chloride in a fixed-bed reactor was independent of methanogenesis. The authors suggest that methylene chloride is hydrolyzed to formaldehyde which is then metabolized by a number of anaerobic microorganisms, including methanogens. The results observed in my enrichment experiments may indicate that the appropriate consortia of bacteria was not present for an interrelated pathway, such as the two described, to occur and that

dechlorination by pure cultures of methanogens may not be possible due to the dependence on functions performed by other microorganisms, such as acetogens.

The dechlorination of methylene chloride by fortuitous involvement in the methanogenic pathway may still be a viable hypothesis, despite the lack of experimental evidence obtained in the work presented here. The following chapter discusses the dechlorination of halogenated methanes by metal-centered cofactors, some of which are produced by methanogens. Results of the experiments reported in Chapter 3 indicate that corrinoids, similar to methanogenic cofactors, are able to reductively dechlorinate methylene chloride in the presence of an electron donor.

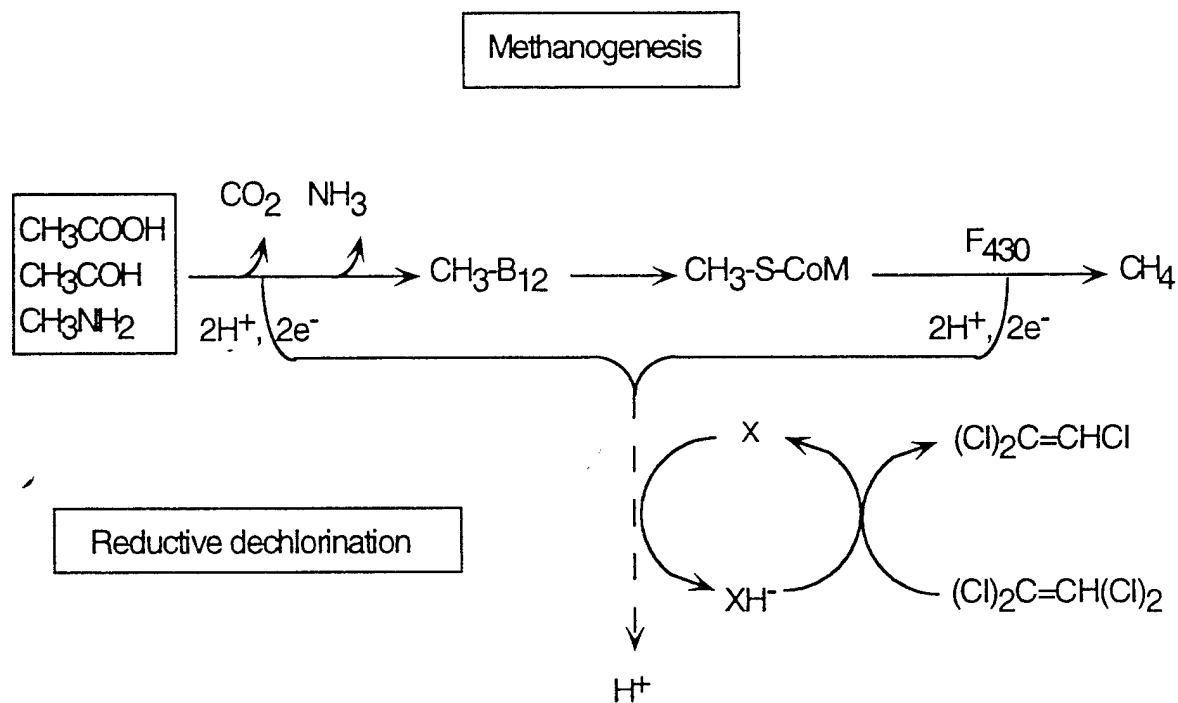

Figure 2.1 Scheme showing possible mechanism of reductive dechlorination by methanogens, proposed by Fathepure and Boyd [45] for the pathway of tetrachloroethylene reductive dechlorination by methanogens. Electrons may be transferred to the halogenated substrate via an electron carrier (X) involved in methanogenesis.

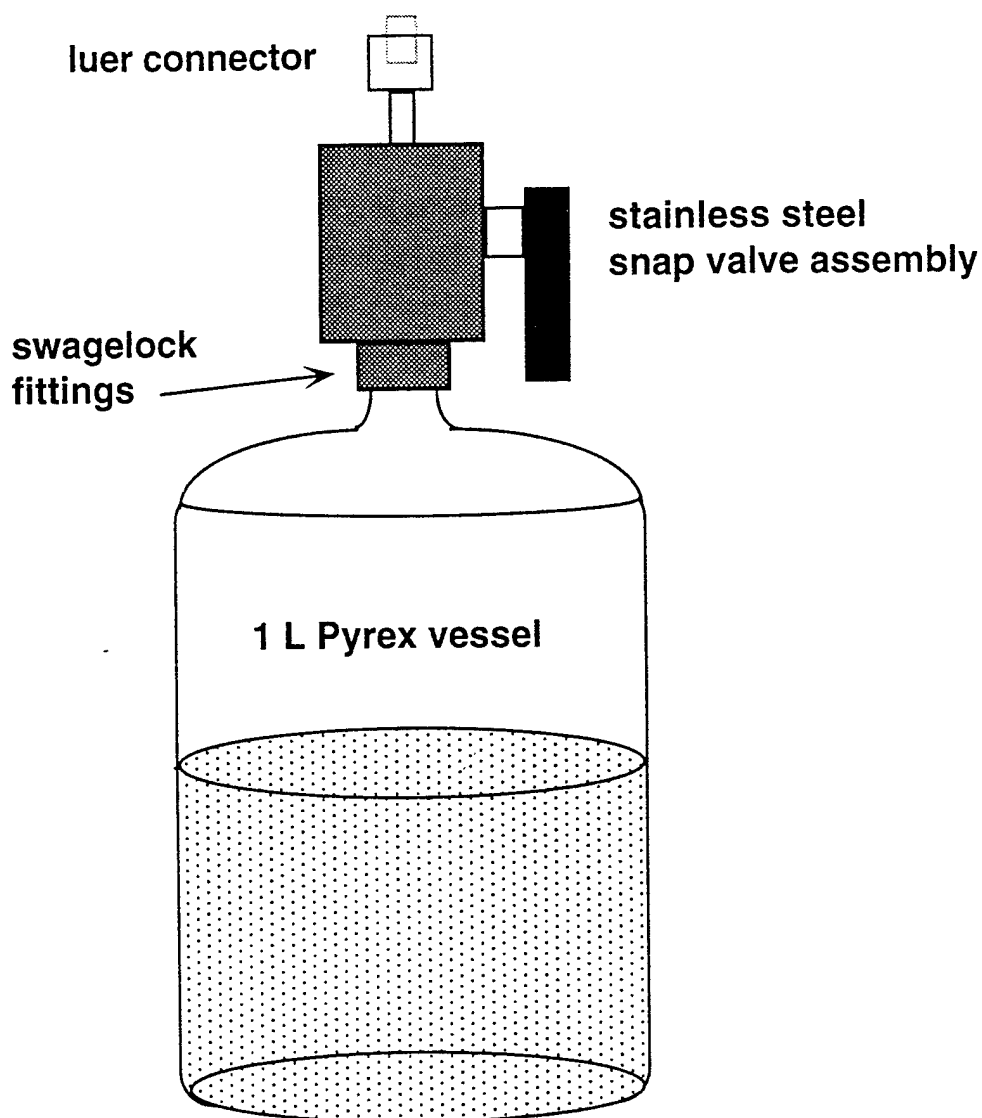

Figure 2.2 Schematic depicting the gas-tight culture vessel. A 1-L Pyrex bottle was connected, via swagelock fittings, to a valve with snap closure for use with volatile halocarbons in biotic dehalogenation experiments.

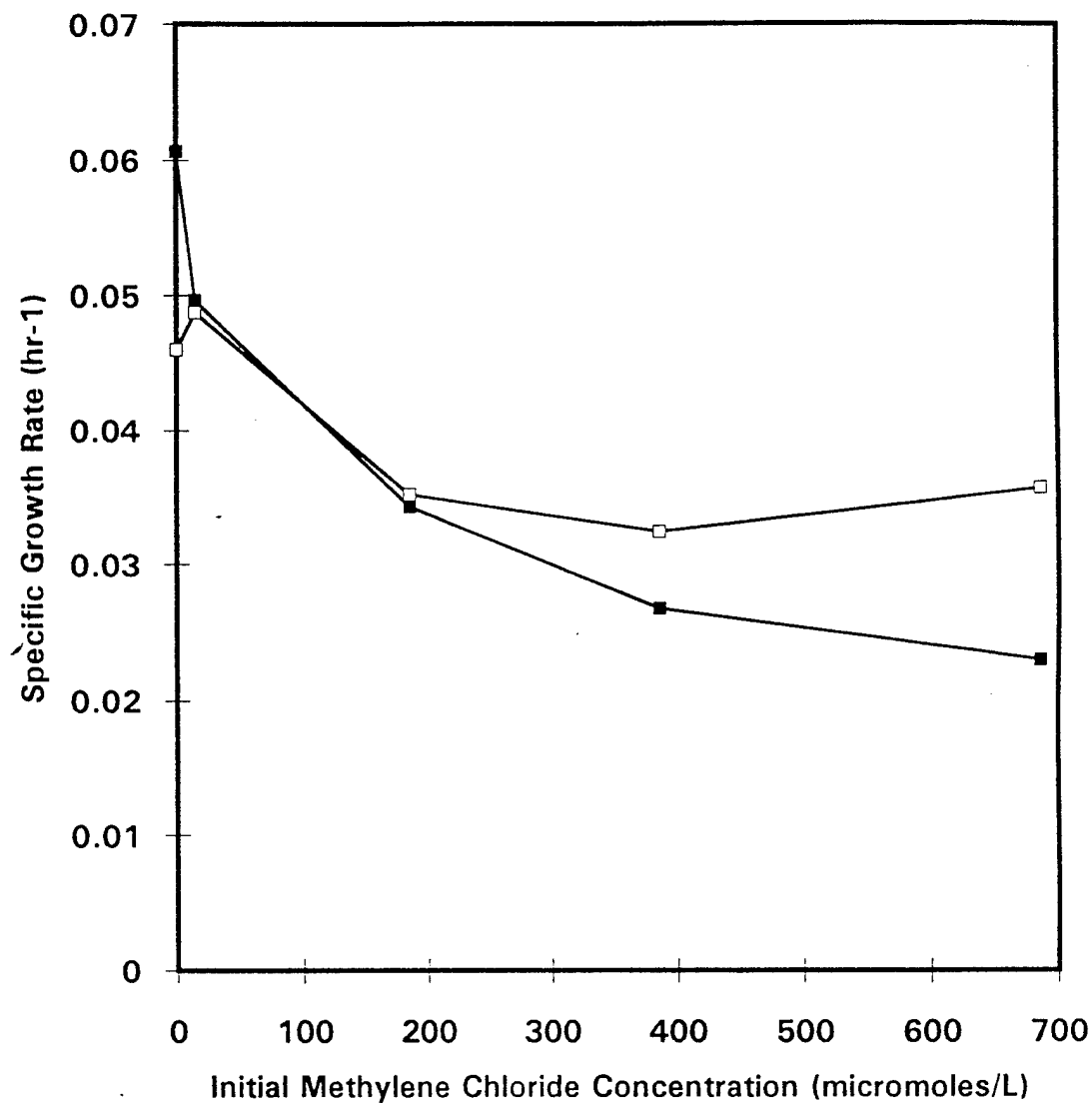

Figure 2.3 Results showing that a minimum inhibitory concentration was not obtained for two pure cultures of *Methanosarcina* in serum bottle experiments. A slight decrease in specific growth rate of *Methanosarcina mazei* S-6 (closed squares) and *Methanosarcina barkeri* 227 (open squares) was observed with exposure to increasing concentrations of methylene chloride. Cultures were grown on 50 mM methanol at 37 °C.

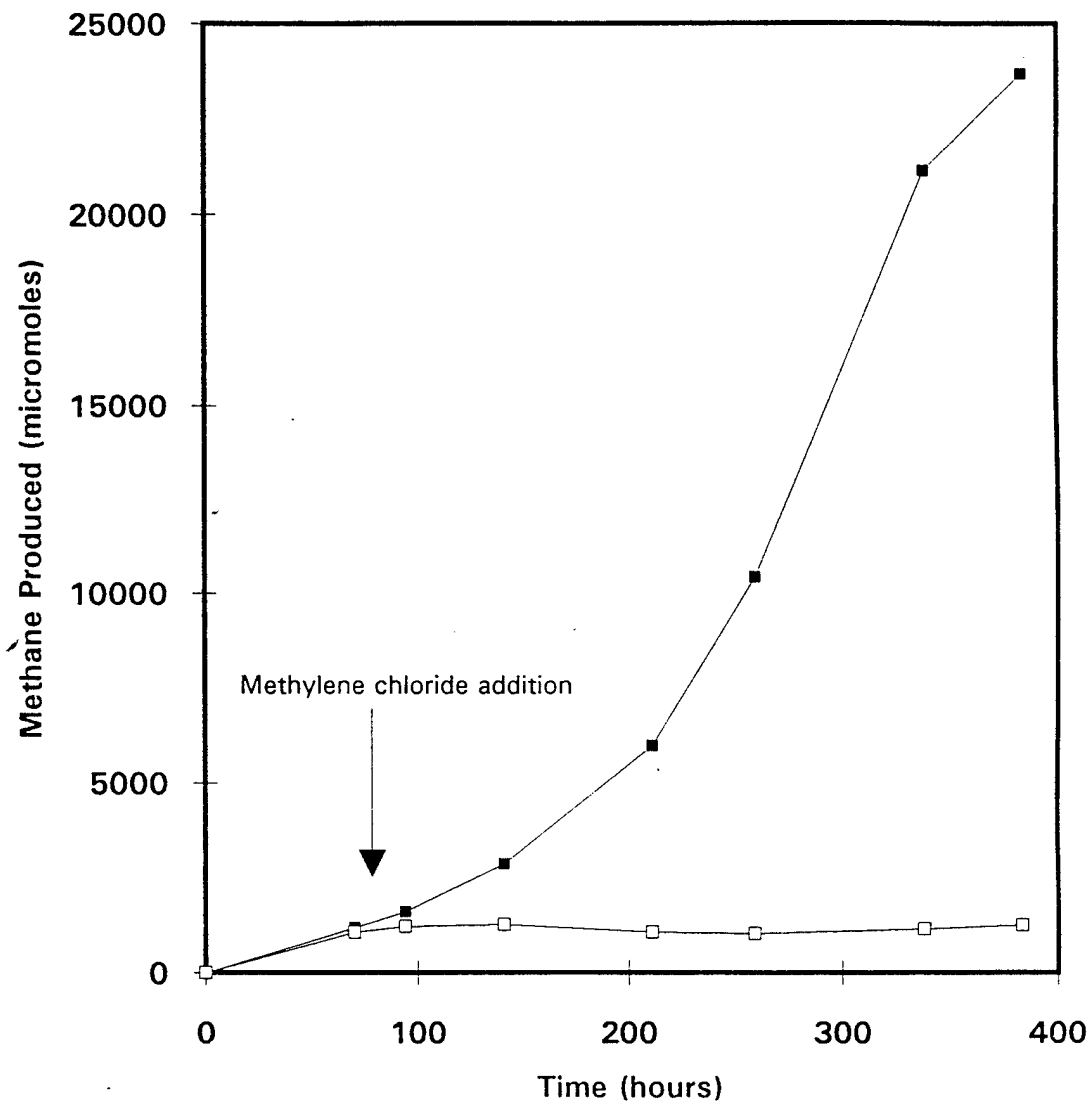

Figure 2.4 Complete inhibition of *Methanosarcina mazeii* S-6 by 100 μ M methylene chloride added after 72 hr of growth on 100 mM acetate (open squares). Closed squares represent an identical culture that did not receive methylene chloride.

Chapter 3

Reductive Dehalogenation of Chlorinated Methanes by Immobilized Cobalamins

Leah J. Matheson, Richard L. Johnson, and Paul G. Tratnyek

Abstract

Cyanocobalamin is one of many biologically-produced, metal-centered macrocyclic compounds that are capable of mediating the transfer electrons from a donor to an oxidized substrate. Substrates that these mediator compounds are able to reduce include halogenated hydrocarbons and nitroaromatics. In experiments presented here, cyanocobalamin reduced with Ti(III)citrate in an aqueous buffer suspension was able to rapidly dechlorinate carbon tetrachloride. In these systems the rate of dechlorination appeared to be pseudo-first order in chlorinated substrate. Chloroform, methylene chloride, chloromethane, and methane were observed as products in stoichiometric amounts. Immobilization of cyanocobalamin on solid supports was investigated as a way to take advantage its catalytic nature. Cobalamins bound to EA-Sephacrose and talc were able to reductively dechlorinate halogenated methanes, with little loss in activity. However, the dechlorination of carbon tetrachloride by Sephacrose-bound (dicyano)cobalamin did not follow first order kinetics. The deviation from first-order behavior may have been due to limiting amounts of cobalamin present, or conformational changes in the cyanocobalamin structure during the binding process. However, when cyanocobalamin was bound to talc, dechlorination rates were pseudo-first order in chlorinated substrate. The dechlorination of carbon tetrachloride by talc-bound cyanocobalamin demonstrates the effectiveness of a relatively inexpensive material for immobilization of biochemical catalysts. The ability of the clay mineral, talc, to immobilize cyanocobalamin raises the possibility that bacterial forms of these compounds, released into the environment by cell lysis, are immobilized by geologic materials common in the natural environment.

Introduction

The reduction of halogenated hydrocarbons and nitroaromatics is an important process determining the fate of these compounds in contaminated soils and groundwaters. In many cases, this process occurs more rapidly than can be explained simply by reaction with available bulk reductants. One explanation for the high rate of reaction in these systems is the presence of a "mediator" that facilitates the transfer of electrons from a donor to the organic substrate (Figure 3.1). Only recently have studies involved the mediator concept in the reduction of chlorinated organics and these have, so far, been limited to studies in laboratory model systems and studies focusing on analogies to natural mediator cycles. In the research reported here the possibility is extended that mediators can become useful tools in remediation technologies by immobilization.

In most cases, direct experimental evidence for mediation of redox processes in the environment has been limited. However, circumstantial evidence and arguments based on biochemical analogies have led to widespread acceptance of the role of mediators in environmental pollutant reduction reactions. The types of substances presumed to be responsible for this process are essentially similar to biochemical redox mediators. A variety of these compounds are produced by microorganisms, including porphyrins, corrinoids, flavoproteins, iron-sulfur proteins, and other coenzymes and cofactors [36, 116]. Compounds that may have remote microbial origins, such as the polyphenolic (hydroquinone) moieties of natural organic matter, may also mediate redox reactions in the environment. Other potential mediators include inorganic metal complexes and free metals. In order for any of these compounds to serve as mediators, these substances must have sufficiently low redox potentials for electron transfer to the organic pollutant to be thermodynamically feasible [107, 141]. An example of the ability of metallomacrocycles to serve as redox mediators can be given by iron(II)porphyrin. The potential formed by the Fe(II)/Fe(III) redox couple becomes more reducing in the chelated form, making it a reductant relative to many organic pollutants [141]. Similarly, the redox potential of the cobalt couple in the center of

cyanocobalamin becomes more reducing by its chelation in the tetrapyrrole ring. Cyanocobalamin, or vitamin B₁₂, is produced in large quantities by some anaerobic microorganisms. Other important metallomacrocycles include the nickel-centered heme, factor F₄₃₀ [36, 73], and the iron-centered heme, cytochrome P-450 [29].

The microbial metallomacrocycles have received much attention for their ability to catalyze the reduction of halogenated organic compounds in laboratory studies. As early as 1968, chlorinated methanes were observed to react with the cobalt-centered corrinoid, cyanocobalamin, to produce chloromethylcobalamins and hydrochloric acid [151]. Methanogenesis was inhibited in these systems by the chlorinated methanes as a result of the inhibition of the cobamide-dependent methyl-transfer reaction. In 1971, Hill and coworkers [60] demonstrated the reduction of alkyl halides using controlled potential analysis as a model system for the formation of methane from methylcobalamin by methanogens. At electrode potentials more reducing than the reduction potential for the alkyl halide, the cobalamin-catalyzed reaction was shown to be a two-electron reduction. Wade and Castro [145, 146] demonstrated that alkyl halides oxidized the iron metal center of hemes and porphyrins, with concomitant reduction of the C-H bond to yield a radical species. Many of these earlier studies focused on the reaction of biological systems, mammalian and microbiological, to environmental pollutants from a toxicological perspective. Metallomacrocycles of these systems were studied for their physiological importance in biological detoxification mechanisms [149, 150].

As more metallomacrocycles were discovered, and more became known about the biochemistry of these compounds, research began to focus on the reduction of environmental pollutants to gain an understanding of these mechanisms in laboratory systems and natural environments. Several studies [9, 11, 92, 118] demonstrated the reductive dechlorination of pesticides catalyzed by reduced cobalamin. More recently the reduction of a variety of halogenated methanes and ethanes catalyzed by metallomacrocycles has been gaining considerable attention [7, 29, 48, 70, 73, 75, 76, 87, 88, 115, 144].

Gantzer and Wackett [48] studied dechlorination mediated by several metallomacrocycles in model biochemical systems. These researchers were able to extend their results from laboratory model systems to simulate reaction kinetics observed in microbial dehalogenation reactions. They proposed that microorganisms bio-engineered for increased production of these transition-metal coenzymes could lead to organisms with enhanced biodegradative capabilities.

An alternative remediation strategy to the use of macrocycle-enriched microorganisms is to apply the transition-metal cofactors themselves. Since these compounds are essentially acting as catalysts they can be reused but need to be kept from washing out of the system, or being degraded. Immobilization of the metallo-macrocycle is one possibility to use the catalyst more efficiently in contaminant transformation processes. This was the motivation behind the work of Marks and Maule [93, 94], who immobilized porphyrins and corrinoids on a variety of supports and demonstrated the ability of these bound compounds to effect reductive dehalogenation. Sepharose, Sephadex, and polystyrene beads were used as supports for the metallomacrocycles in their studies. The immobilized compounds were able to mediate the dehalogenation of lindane, carbon tetrachloride and methylene chloride to varying degrees. The type of support, and the binding process used, was observed to have an effect on the dehalogenating activity of the immobilized complex.

Other materials have been used to immobilize metallomacrocycles, including polymer films [100] and insoluble surfactant films [95]. The immobilization of cyanocobalamin on talc was observed by researchers studying the pharmaceutical properties of this corrinoid [91, 98, 99]. Macek and Feller [91] observed that cyanocobalamin was quantitatively adsorbed by talc in aqueous solutions and could not be eluted from the talc by aqueous extraction. They concluded that talc renders cyanocobalamin useless in pharmaceutical preparations due to unavailability of the cobalamin for absorption *in vivo*. Moriguchi and Kaneniwa [98, 99] showed cyanocobalamin adsorption on talc to be 10-fold higher than other water-insoluble pharmaceutical lubricants. Neither of these studies elucidated a mechanism for the immobilization of cyanocobalamin on talc.

In the research reported here, the immobilization of cyanocobalamin to Sepharose and talc is demonstrated. The effect of immobilization of cyanocobalamin on the reductive dechlorination of carbon tetrachloride, and the use of this immobilized complex is explored as a means to enhance pollutant remediation techniques. The novel use of talc to bind cyanocobalamin may be a significant strategy for dehalogenation of environmental contaminants. Talc, $\text{Mg}_3\text{Si}_4\text{O}_{10}(\text{OH})_2$, is a mineral clay that occurs naturally in the environment, and may also serve as a model for the immobilization of microbial enzymes and cofactors in the subsurface.

Experimental

Chemicals. Chlorinated solvents were obtained in high purity and used without further purification. These included carbon tetrachloride, HPLC grade (Aldrich); chloroform, LC grade, preserved with 1% (v/v) ethanol (Burdick & Jackson); methylene chloride, 99+%, anhydrous (Aldrich); and chloromethane, 99.5+% (Aldrich). Saturated aqueous stock solutions of these halocarbons were prepared by allowing roughly 1 mL of organic phase to equilibrate with 40 mL of deionized water (NANOpure, 18 M Ω -cm) in glass vials capped with Teflon Mininert valves. Aqueous standard solutions were made by diluting the saturated stock solutions with deionized water. Cyanocobalamin (99%) was obtained from Aldrich and 0.46 mM stock solutions were made either in O₂-free deionized water without buffer, or with 0.66 M tris(hydroxymethyl)aminomethane (Tris, Trizma) buffer. (Dicyano)cobalamin was prepared as a 59 μ M stock solution in 1 mM KCN, pH 9.3. The dried EA-Sepharose 6B (Pharmacia) gel was washed with 100 mL deionized water per 1 g (dry wt) of gel, and incubated with the (dicyano)cobalamin stock solution in a foil-covered flask, in a 37 °C water bath for 24 hr. The Sepharose-bound cobalamin was filtered through a glass microfiber filter and washed with 150 mL deionized water, 100 mL of 0.1 M bicarbonate buffer (pH 8), and 0.1 M acetate buffer (pH 4). The gel-cobalamin complex was incubated for 4 hr in 1 M ethanolamine in a 40 °C water bath, then rinsed with deionized water and filtered before use. All solutions were assayed for cobalamin, before and after adsorption. A flaky, white talc originating from Balmat, New York was purchased from Ward Scientific, and ground with a coffee grinder until powdery before use. A 2-g sample of talc was incubated in 50 mL buffered cyanocobalamin solution at 20 °C, in a foil-covered flask, on a platform shaker at 200 rpm. The talc-cobalamin was filtered and washed with 40 mL deionized water two times before use.

Buffers were reagent grade and used as received (Sigma). These included Tris, 2-(N-morpholino)ethanesulfonic acid (MES), 3-(N-morpholino)propanesulfonic acid (MOPS). Anaerobic solutions of all media were prepared by purging for roughly 1 hr

with zero-grade N_2 that was deoxygenated by passing through a heated column of reduced copper.

Analyses. Two chromatographic methods were used at various stages of this study to determine the aqueous concentration of chlorinated solvents. In one method a 0.1-mL sample was withdrawn, via an evacuated chamber, from the headspace of the sample vial kept at 25 °C in a water bath. This was then injected into a 30-m x 0.53-mm ID (5% phenyl) 95% methylsilicone capillary column (Supelco) in an oven heated to 150 °C. Satisfactory results were obtained with FID. Aqueous concentrations were calculated from the headspace gas concentrations using the appropriate Henry's Law constants at 25 °C [55]. The second gas chromatography method used a modification of the method for direct aqueous injection on capillary columns developed by Grob [56]. A 2- μ L liquid sample was taken directly from the reaction bottles and injected via an on-column inlet at 92 °C, to a 2.5-m x 0.53-mm ID precolumn attached to a 30-m x 0.53-mm ID DB 624 analytical column (J&W) in an oven heated to 104 °C. Satisfactory results were obtained with detection by FID. Peaks were identified by comparison with the retention times of standard compounds. Methane was determined from a gas sample taken from the headspace of the model system by two chromatographic methods: the first method described above, and by analyzing a 10 μ L gas sample removed from the headspace of the culture vessel for methane by gas chromatography with a 2 m x 4 mm ID column packed with activated charcoal and quantification by FID.

Cobalamin concentrations were determined spectrophotometrically from their absorbances at 551 nm for cyanocobalamin (molar extinction coefficient, $\epsilon = 8740 \text{ mL}(\text{mmol}^{-1})$) and 543 nm for (dicyano)cobalamin ($\epsilon = 8600 \text{ mL}(\text{mmol}^{-1})$) [117]. Calibration curves were also developed for the two cobalamin compounds. Concentrations determined via response factors generated from the calibration curve or from the molar extinction coefficients were not significantly different, and both methods were used.

Dehalogenation Studies. Two types of batch systems were used for dehalogenation studies. Initial studies were carried out in 10-mL foil covered serum bottles with 1-mL liquid volume and N_2 -sparged headspace. These were incubated at 25 °C in a temperature controlled water bath. Later studies used 60-mL foil covered

unless otherwise noted) and incubated at room temperature, ca. 25 °C. An aqueous, saturated stock solution of chlorinated compound was added through the stopper at the initiation of the dechlorination experiment. One-half hour prior to the addition of chlorinated substrate, Ti(III) citrate [154] was added to reduce the cyanocobalamin. Table 3.1 lists the amounts of each component used for the different experiments. The bottles were mixed immediately after this addition, and throughout the experiment, either by hand at regular intervals or on a rotary shaker at 15 rpm (approx. 15 cm orbit radius).

Results and Discussion

Dehalogenation by Ti(III) and Other Losses. In order to achieve dechlorination mediated by cyanocobalamin in batch systems, it is necessary to provide a bulk electron donor that reduces the mediator before it reacts with the halogenated substrate. Ti(III) citrate has been used as an electron donor in similar studies of this nature [48, 75], and was also found to be effective in the dehalogenation studies reported here. In control experiments for reduction by the electron donor alone, Krone and co-workers [75] observed slow reduction of carbon tetrachloride by Ti(III) that ceased after 30 min. Ti(III) was not observed to dechlorinate methylene chloride and chloromethane in their studies. Gantzer and Wackett [48] reported that no reduction of chlorinated ethylenes or aromatics occurred in the presence of their Ti(III)-only controls. In the dehalogenation experiments reported here, controls containing 27 μmol Ti(III) citrate in anoxic, aqueous solution did not produce measurable loss of carbon tetrachloride although small amounts of methylene chloride (< 1% of the parent substrate concentration) were produced over the duration of the dehalogenation experiments (120 minutes). This reduction is not significant compared to the dechlorination rate in the presence of the cobalamin and results were not routinely corrected for this.

Losses of 0-10% of carbon tetrachloride to the stopper were observed in controls containing only the chlorinated substrate in anoxic, aqueous systems during the duration of these dehalogenation experiments (120 minutes). Methylene chloride losses in substrate-only controls were much higher at 10-20%, probably due to the increased duration of these experiments (typically 3 days). Results are reported without correction for these losses.

Dehalogenation With Unbound Cobalamin. Initial experiments with cyanocobalamin were designed to be comparable to studies previously reported by others [48, 73, 75]. Similar reduction rates and products were observed in the studies

reported here. Both cyanocobalamin and (dicyano)cobalamin catalyzed the reduction of carbon tetrachloride and methylene chloride to sequentially reduced products, with Ti(III) as the reductant. Figure 3.2 illustrates the product distribution observed in a typical dehalogenation experiment. Chloroform, methylene chloride, chloromethane and methane were produced during cobalamin-catalyzed reduction of carbon tetrachloride. Mass balance was approximately 100% during the entire dechlorination process.

The data in Figure 3.2 have been fit by nonlinear regression to the integrated rate laws for the sequential first-order reactions [27]:

$$[\text{CCl}_4]_t = [\text{CCl}_4]_{\text{max}} e^{-k_1 t} \quad (1)$$

$$[\text{CHCl}_3]_t = \frac{[\text{CHCl}_3]_{\text{max}} k_1}{k_2 - k_1} (e^{-k_1 t} - e^{-k_2 t}) \quad (2)$$

$$[\text{CH}_2\text{Cl}_2]_t = \frac{[\text{CH}_2\text{Cl}_2]_{\text{max}} k_2}{k_3 - k_2} (e^{-k_2 t} - e^{-k_3 t}) \quad (3)$$

$$[\text{CH}_3\text{Cl}]_t = \frac{[\text{CH}_3\text{Cl}]_{\text{max}} k_3}{k_4 - k_3} (e^{-k_3 t} - e^{-k_4 t}) \quad (4)$$

$$[\text{CH}_4]_t = [\text{CH}_4]_{\text{max}} (1 - e^{-k_4 t}) \quad (5)$$

where k_1 is the first-order rate constant for dechlorination of carbon tetrachloride to chloroform, k_2 is the rate constant for conversion of chloroform to methylene chloride, k_3 is the rate constant for methylene chloride dechlorination to chloromethane, and k_4 is the rate constant for conversion of chloromethane to methane. The results of these calculations are presented in Table 3.2. First-order kinetics were observed in these experiments, verifying that the steady-state concentration of reduced cyanocobalamin was present in excess amount relative to the chlorinated compound. The similarity of the k_3 predicted by equation 3 to that determined in equation 4 indicates that the

dechlorination of chloroform to methylene chloride was adequately described by these equations. However, the differences between the corresponding parameters in Table 3.2, and poor degree of fit for some, suggest that a more complicated pathway than sequential dechlorination may be involved. Similar complexities were observed by Gantzer and Wackett [48] for cyanocobalamin-catalyzed reduction of tetrachloroethylene. Krone and coworkers [75] attempted to explain similar observations in their systems, with either Ti(III) or dithiothreitol as the reductant, by proposing several different reaction schemes in which the cobalt center of the active cobalamin was in the +1 oxidation state. Recently, Assaf-Anid and coworkers [7] reported the results of a mechanistic study of carbon tetrachloride reduction by cyanocobalamin. Their results indicated that cobalamin(II) is the predominant form in the presence of the reductant dithiothreitol. However, their results differ from the results of my experiments since carbon tetrachloride reduction in these systems did not yield stoichiometric amounts of sequentially reduced products. The authors propose the formation of non-volatile or non-chlorinated products that would not be identified by their analytical method. Sufficient reductant and cobalamin concentrations were used to ensure that these compounds were not limiting factors in the reaction kinetics, suggesting that it was the reaction pathway that differed in these experiments. Their studies also indicate that the reaction pathway for dechlorination of chlorinated alkanes by cyanocobalamin is complex and may be very sensitive to system conditions.

When methylene chloride was the initial substrate in the studies reported here, dechlorination by reduced cyanocobalamin occurred at similar rates and exhibited similar product distributions as the methylene chloride disappearance in experiments where it was generated as a product of sequential dechlorination of carbon tetrachloride. The natural logarithm of the disappearance of methylene chloride concentration with time is shown in Figure 3.3.

Immobilization of Cobalamin on Sepharose. Sepharose-immobilized cobalamin was studied to determine whether the bound metallomacrocycle can also catalyze dechlorination. Demonstration of immobilization of cyanocobalamin, without reduction of its dechlorinating activity, could form the basis for remediation strategies using cyanocobalamin. A well-defined polymer, EA(epoxy activated)-Sepharose 6B, was used to immobilize (dicyano)cobalamin for dechlorination studies. EA-Sepharose is designed for making stable linkages with small ligands used to recognize target compounds in affinity chromatography. EA-Sepharose is formed by reacting Sepharose

6B with 1,4-*bis*-(2,3-epoxypropoxy-) butane. A stable ether-linkage is formed between the hydrophilic spacer and the matrix. Free oxirane groups couple via: i) ether bonds with hydroxyl moieties; ii) alkylamine linkages with amino groups; or iii) thioether linkages with thiol groups.

In this study, approximately 1.92 μmol of (dicyano)cobalamin was immobilized on 1 g (dry wt) Sepharose at pH 9.3. This is less than 3% of the total EA-Sepharose binding sites, giving approximately 97% of unbound oxirane groups. The experimental conditions during binding, e.g. pH and temperature, may have not been optimal for efficient binding of the cobalamin to EA-Sepharose. A faster rate of dechlorination was obtained with cobalamin bound to EA-Sepharose at pH 11 (data not shown), although the amount of cobalamin bound was not measured in these experiments. While the high degree of unbound sites might be able to bind metals and become catalytic themselves, the ethanolamine step of the binding procedure described above should block any unreacted sites. Since Sepharose controls were not performed without bound cyanocobalamin, it is difficult to rule out the activity of the unbound sites.

The binding of cyanocobalamin to EA-Sepharose may have also occurred via coupling through the cobalt center of the molecule. Chelation of divalent cations is possible with a form of Sepharose containing a *N*-hydroxysuccinimide spacer arm. EA-Sepharose may also bind divalent cations, and thus bind Co(II)-cobalamins through the metal center of the molecule, negatively affecting the ability of the mediator to participate in the dehalogenation process.

Dehalogenation of Chlorinated Methanes by Sepharose-Bound Cobalamin.

EA-Sepharose-immobilized (dicyano)cobalamin, in the presence of Ti(III), catalyzed the dehalogenation of chlorinated methanes to sequentially reduced products. The gel-bound cobalamin could be recycled by washing and filtering with deionized water, without measurable loss of cobalamin. The recycled gel exhibited dechlorination rates similar to the initial experiments. The ratio of Ti(III) to cobalamin to chlorinated compound was 42:1:2.5, which is a sufficient excess of reductant to allow for first-order reaction conditions. However, the observed disappearance kinetics in all experiments consistently indicate that the reaction rate declines with time (Figure 3.4). There are several possible explanations for the tailing of the data. One of which is that the amount of active cobalamin present may have been reduced because of the chelation the cobalt center, thus the system may have become limiting in cobalamin concentration

and subject to second-order kinetics. In an experiment similar to the one performed here, Marks and Maule [94] observed that cobalamin and porphyrins were able to catalyze dechlorination when bound to polystyrene beads but not Sepharose. In their experiments, cobalamins bound to several types of activated Sepharose were unable to catalyze the dechlorination of halomethanes in the presence of a reductant. These results indicate that the dechlorinating activity of metal-centered macrocycles is affected by the binding of these compounds on various types of activated Sepharose.

Although the dicyano form of the cobalamin was bound to Sepharose in our experiments, the unbound form was able to catalyze rapid dehalogenation reactions with first-order kinetics similar to the experiments presented above for unbound cyanocobalamin (data not shown).

Immobilization of Cobalamin to Talc. Talc was selected as an alternative support for cyanocobalamin based on its prior demonstration of irreversible sorption of this cofactor [91]. Using the procedure described above, and exposing the talc to cyanocobalamin for 24 hr, 90-210 nmol cobalamin was bound per g talc (dry wt). This is approximately 1/26th the amount bound per g (dry wt) in the Sepharose experiments.

Figure 3.5 shows that the pH of the binding solution affected the amount of cyanocobalamin immobilized to talc, with more cyanocobalamin immobilized by talc at lower pH values. The effect of pH on binding to talc may be due to the replacement of CN in the β position by OH at more alkaline pH values [117].

The experimental conditions, e.g. pH and temperature, could have affected the binding mechanism by the talc material itself. The mechanism for cyanocobalamin adsorption to talc has not been described in detail, even though this phenomenon has been known for many years [91]. Moriguchi and Kaneniwa [98, 99] observed that adsorption of cyanocobalamin to talc in controlled laboratory experiments could be described with Langmuir isotherms. However, these authors did not speculate on the mechanism of binding. Porphyrin complexation with montmorillonites, of the same clay-mineral group as talc, was observed by van Damme and coworkers [139]. Various degrees of protonation of the porphyrin complexes were observed during adsorption on the montmorillonites. The protonated forms of the metallomacrocycles are more likely to be intercalated between the negatively charged silicate sheets. This suggests that lower pH values might be more conducive for metallomacrocycle adsorption which is consistent with the results shown in Figure 3.5. These observations are speculations of

the author and may not extend to talc because talc interlayers, unlike those of montmorillonite, do not favor cation exchange reactions [12].

Dehalogenation of Chlorinated Methanes by Talc-Bound Cobalamin. Talc-immobilized cyanocobalamin, with Ti(III) as the reductant, catalyzed the dehalogenation of both carbon tetrachloride and methylene chloride. Plots of natural logarithm of carbon tetrachloride concentration versus time (Figure 3.6) were observed to be linear (1-3 half-lives, typical $r^2 \sim 0.9$, $n=4-8$), indicating that the reaction rate was first-order in substrate concentration. The rate of dechlorination observed with talc-immobilized cyanocobalamin ($k_{\text{obs}}=0.028$, $r^2=0.996$, $n=8$) was 0.7 times the rate observed with the unbound cobalamin ($k_{\text{obs}}=0.040$, $r^2=0.992$, $n=4$). This lower k_{obs} of the talc-bound cyanocobalamin is probably due to the difference of cobalamin present in the bound versus unbound bottles. The unbound cobalamin was present at approximately twice the concentration of the bound cobalamin concentration in this experiment. The relative concentrations of Ti(III) to talc-bound cyanocobalamin to carbon tetrachloride was 314:1:6.6. Similarly to all previous experiments, sequentially reduced products were observed, with the terminal product being methane. Mass balance for these experiments was approximately 70%. Not included in this calculation is the detection of a small peak that increased throughout the cobalamin-talc dechlorination studies, and was qualitatively identified as hexachloroethane by comparison with aqueous samples of this compound but was not quantified. This product could be formed by coupling of trichloromethyl radicals during the dechlorination process (Figure 1.1).

Control experiments showed that carbon tetrachloride concentrations decreased in the presence of Ti(III) and talc without bound cyanocobalamin, over the duration of a two-day experiment. A small amount of chloroform was observed that was less than 1% of the initial substrate concentration, and the rate of disappearance was one order of magnitude slower than in the presence of cyanocobalamin. It is not surprising that talc should catalyze some dechlorination in the presence of a reductant. Reactions of organics on clay surfaces have been documented [79], but are usually slow relative to the rates of the dechlorination reactions reported here. Kriegmann-King and Reinhard [72] observed these types of slow transformation rates for nucleophilic substitution and hydrolysis of carbon tetrachloride in batch systems containing biotite, or vermiculite, and bisulfide. The transformations were more rapid in systems containing the mineral

than without, but the highest rate observed was two orders of magnitude lower than those observed in our studies with cyanocobalamin bound to talc.

The adsorption of carbon tetrachloride to the clay may also have occurred in the studies reported here. No measurements of sorption were made independent of reaction in these experiments. The possibility of substrate adsorption to the talc is remote in these systems due to the hydrophilic nature imparted to most natural clay materials by the hydration of their surface cations. Kriegmann-King and Reinhard [72] observed adsorption of only 3% of the carbon tetrachloride in studies lasting over 4 weeks. The sorption of organics to clay surfaces can be modified by ion exchange between organic cations and the metal cations on the exchange sites of clays [19]. These modified clay surfaces are relatively organophilic and can sorb alkyl hydrocarbon moieties more efficiently [58, 67]. It is unlikely that the surface of the talc used in this study underwent any exchange reactions with organic cations.

Conclusions and Practical Applications

Immobilized mediators for use in remediation strategies. Metallomacrocycles can be highly efficient catalysts of dehalogenation reactions so small quantities of these compounds should be able to effect significant amounts of dechlorination. However, to be useful in environmental remediation applications, it is necessary to retain the metallomacrocycles in the reaction. Only in this way can these compounds be cost-effective in remediation. This strategy has been employed by several groups for the use of cyanocobalamin in biochemical and engineering processes [93, 94, 95, 100, 117].

Several types of supports can be used to immobilize cyanocobalamin, including polymer coatings [100], insoluble films liquid crystal films of cationic surfactant [95], and polystyrene beads and various forms of activated Sepharose [94]. The family of activated Sepharose materials are appealing model systems for support because of the unreactivity of the Sepharose itself, and the ability to choose a defined mechanism of binding based on the type of ligand. However, the binding process requires additional chemicals that could make activated Sepharose expensive and unwieldy to use. Also, the binding of cyanocobalamin to the functional groups of activated Sepharose materials may interfere with the cobalamins dehalogenating activity towards some halogenated compounds [94].

In an effort to identify a less expensive material for immobilization of cyanocobalamin, talc was studied for its ability to bind this metallomacrocycle for use in dehalogenation studies. Talc-immobilized, Ti(III)-reduced cyanocobalamin was able to reductively dechlorinate carbon tetrachloride in our studies at rates similar to the unadsorbed cobalamins. These findings suggest that talc may be an effective and relatively inexpensive material for the immobilization of metallomacrocycles for use in pollutant remediation strategies. In addition to its potential use in remediation, talc may also bind cyanocobalamin, and other metallomacrocycles in natural systems. Talc is a natural geologic mineral clay belonging to the phyllosilicate subclass of the silicates. The ability to bind metallomacrocycles may also be true for other mineral-clays of this group. Montmorillonite is able to bind porphyrins [139] and immobilization of metallomacrocycles may also be possible with other mineral clays, such as vermiculite, micas,

and pyrophyllite talc. More study needs to be done to determine the types of geologic material that bind metallomacrocycles, and the mechanism(s) of immobilization.

Table 3.1 Initial conditions for dechlorination experiments.^a

Experiment	Cobalamin (μmol)	Ti(III)citrate (μmol)	Halomethane (μmol)
Unbound B ₁₂ ^b	0.046	27	CCl ₄ =2.2 , CH ₂ Cl ₂ =13.2
Sepharose-bound B ₁₂ ^c	0.640	27	CCl ₄ =11 , CH ₂ Cl ₂ =11
0.8 gram gel (wet wt)			
Talc-bound B ₁₂ ^b	0.210-0.090	66	CCl ₄ =10
1 gram talc (dry wt.)			

^aAll experiments were performed at pH 7 in foil-covered vials, incubated at 25 °C on a rotary shaker (15 rpm).

^b cyano form

^c dicyano form

Table 3.2 Kinetics of carbon tetrachloride disappearance.^a

RX	[RX] _{max} (μM)	<i>k</i> ₁ (min. ⁻¹)	<i>k</i> ₂ (min. ⁻¹)	<i>k</i> ₃ (min. ⁻¹)	<i>k</i> ₄ (min. ⁻¹)
CCl ₄	183±1.4	0.21±0.01			
CHCl ₃	68±0.8	0.10±0.98	0.11±1.05		
CH ₂ Cl ₂	17±1.7		0.11±0.06	3.3x10 ⁻⁴ ±1.7x10 ⁻⁴	
CH ₃ Cl	64±0.8			0.11±0.04	3.3x10 ⁻⁴ ±1.7x10 ⁻⁵
CH ₄	157±16				0.01 ±3.0x10 ⁻³

^a Experiment performed at 25 °C in foil-covered vials with 27 μmol Ti(III)citrate, 46 nmol (dicyano)cobalamin, and 2.2 μmol carbon tetrachloride. Uncertainties are one sd in the fitted parameter from nonlinear regression of equations 1-5.

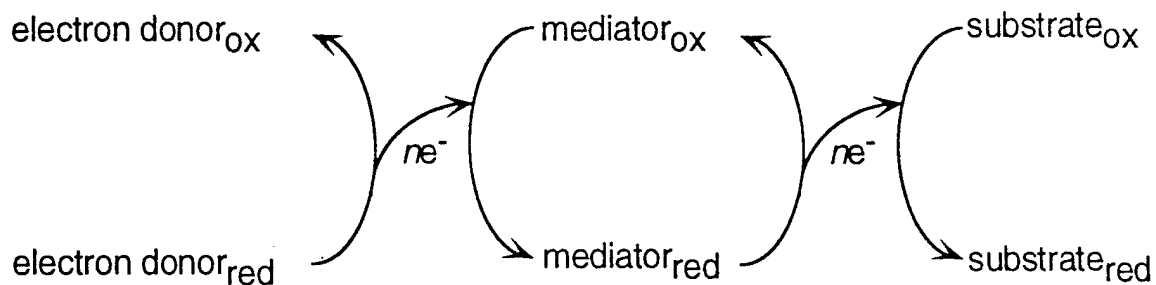

Figure 3.1 Scheme showing proposed pathways for the reduction of organic substrates involving an electron-transfer "mediator". Possible electron donors in the environment include microorganisms, organic matter, and minerals. Probable mediators are porphyrins, corrinoids, flavins, quinones, and enzymes. Substrate examples include halogenated hydrocarbons and nitro aromatics. This figure illustrates the role of the mediator, which is responsible for the accepting electrons from a donor and transferring them to an oxidized organic substrate. The mediator is cycled between reduced and oxidized states. Similar figures can be found in literature, including Glass [53], Esaac and Matsumura [44], Schwarzenbach et al. [119] and Kobayashi and Rittman [71].

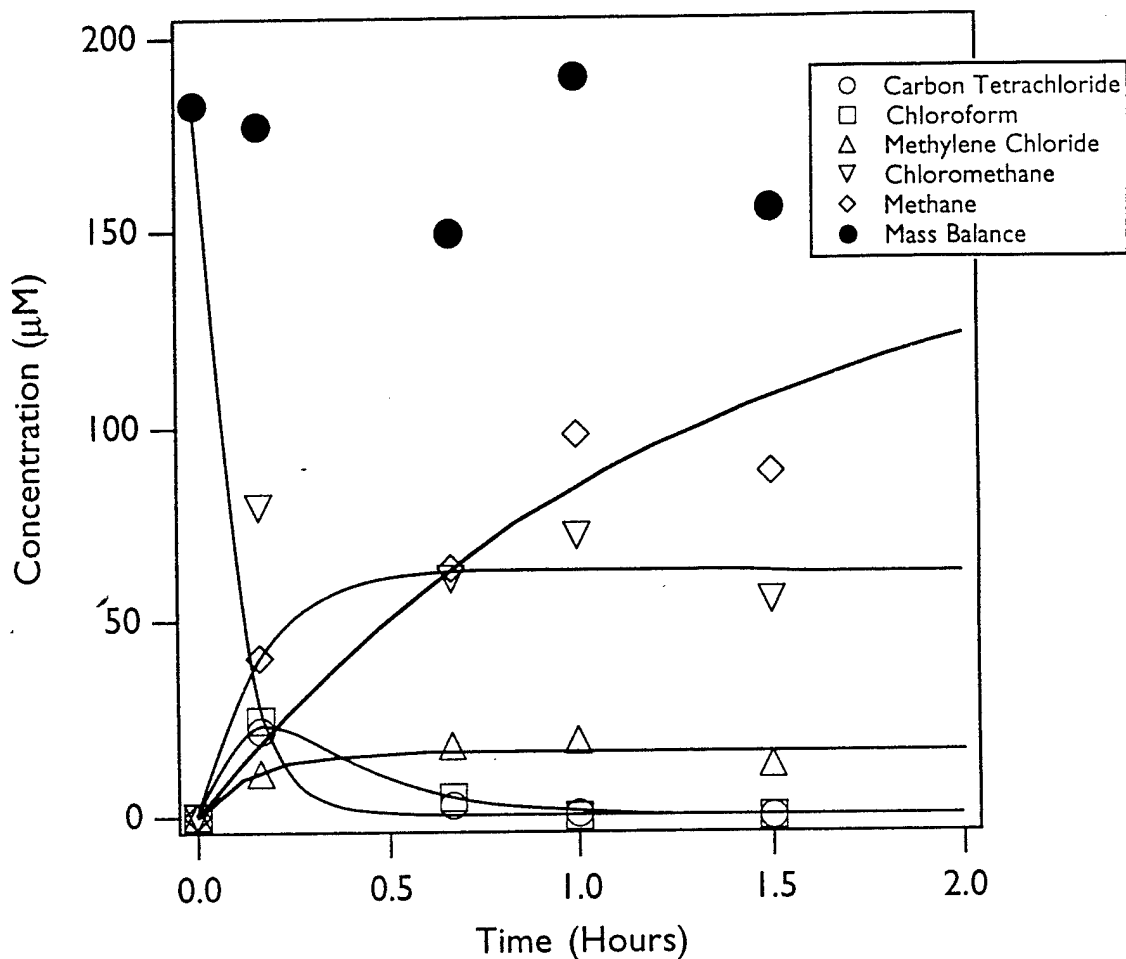

Figure 3.2 Disappearance of carbon tetrachloride with appearance of corresponding sequential dehalogenation products in a system containing 46 nmol cyanocobalamin, 27 μmol Ti(III)citrate, and 2.2 μmol carbon tetrachloride at pH 7, 25°C. Compounds were measured in the gas phase and total concentrations calculated using Henry's Law constants. Graphed values represent total concentrations and regression lines correspond to equations 1-5.

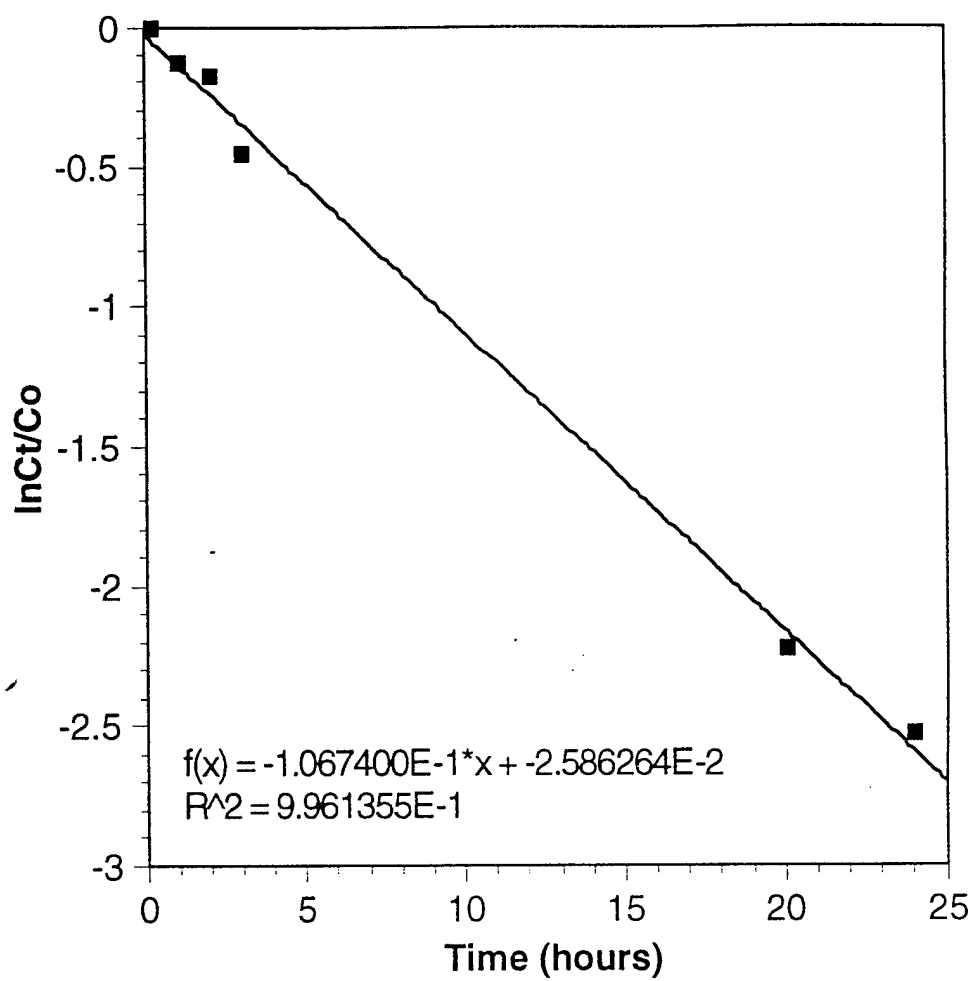

Figure 3.3 First-order disappearance plot for dechlorination of methylene chloride by reduced cyanocobalamin. Experiment: 46 nmol cyanocobalamin, 27 μ mol Ti(III)citrate, and 13 μ mol methylene chloride, at 25 °C, pH 7.

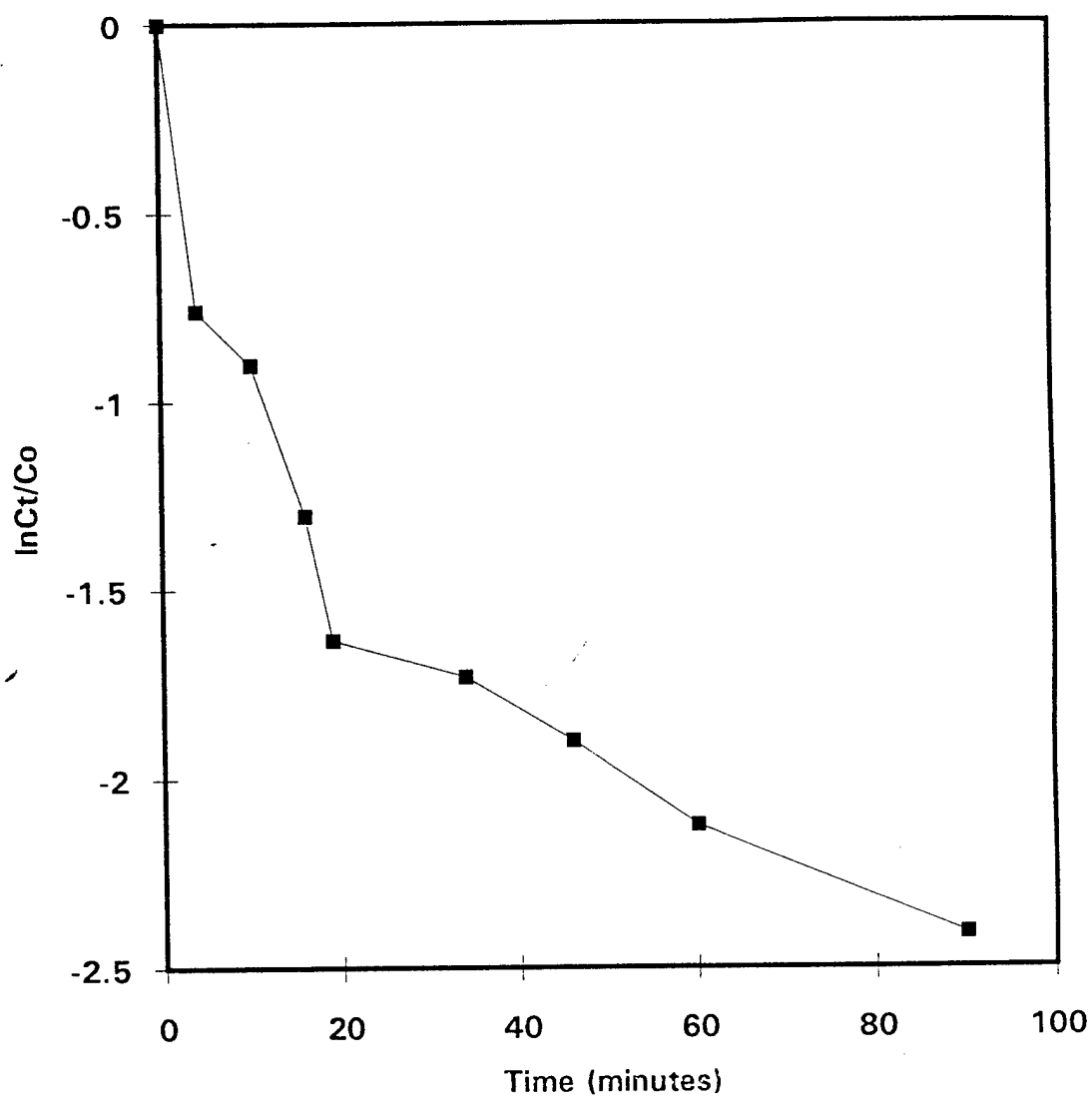

Figure 3.4 Carbon tetrachloride is sequentially reduced by (dicyano)cobalamin immobilized on EA-Sepharose in the presence of a reductant. Cyanocobalamin, 0.64 μmol ; Ti(III)citrate, 27 μmol ; Sepharose, 0.3 g (dry wt.); pH 7; 25°C.

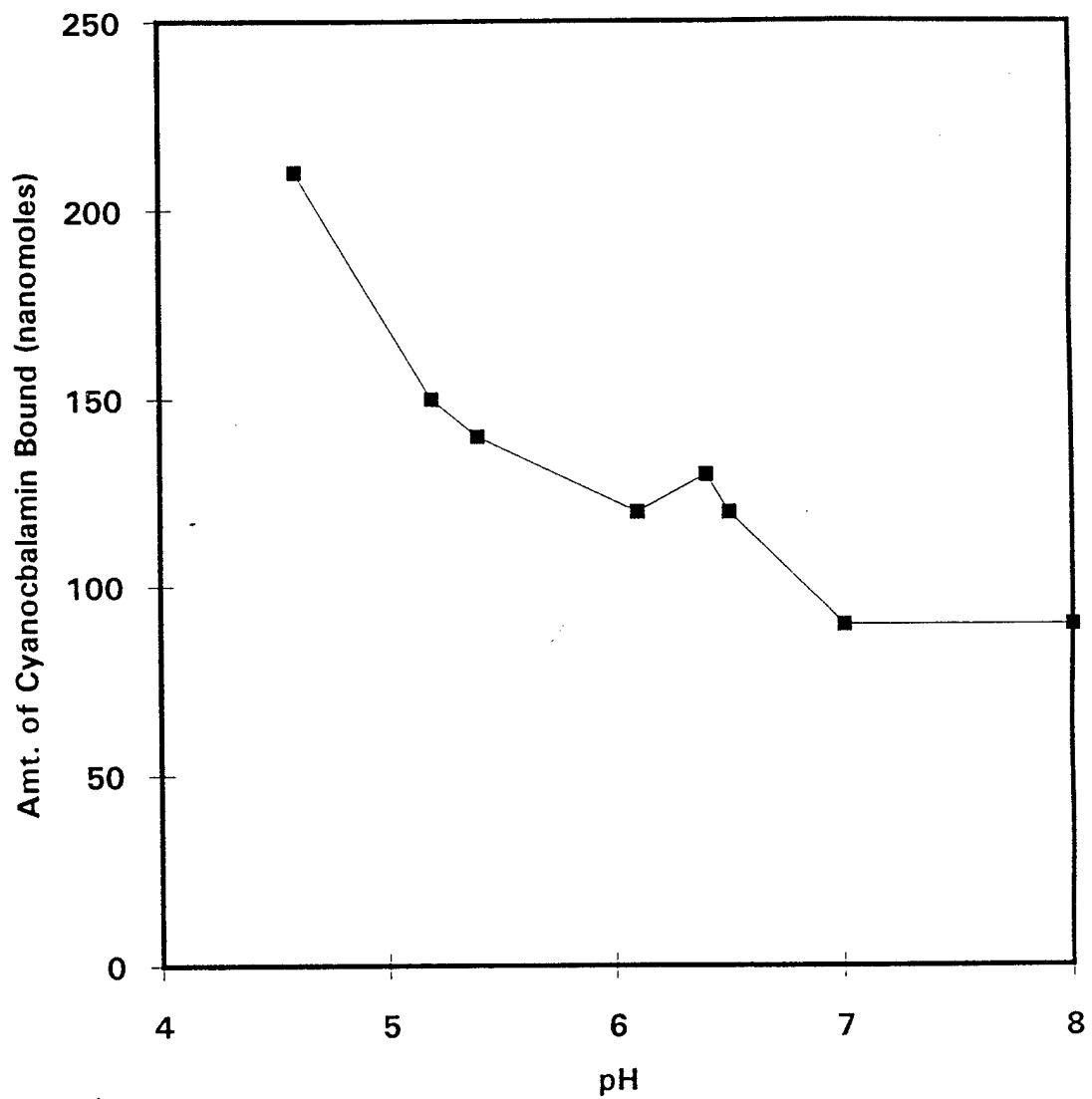

Figure 3.5 Variation of the amount of cyanocobalamin immobilized on talc with variation of pH. Buffers used are described in text. Immobilizations were performed in foil-covered serum bottles incubated on a platform shaker at 20 °C for 24 hr.

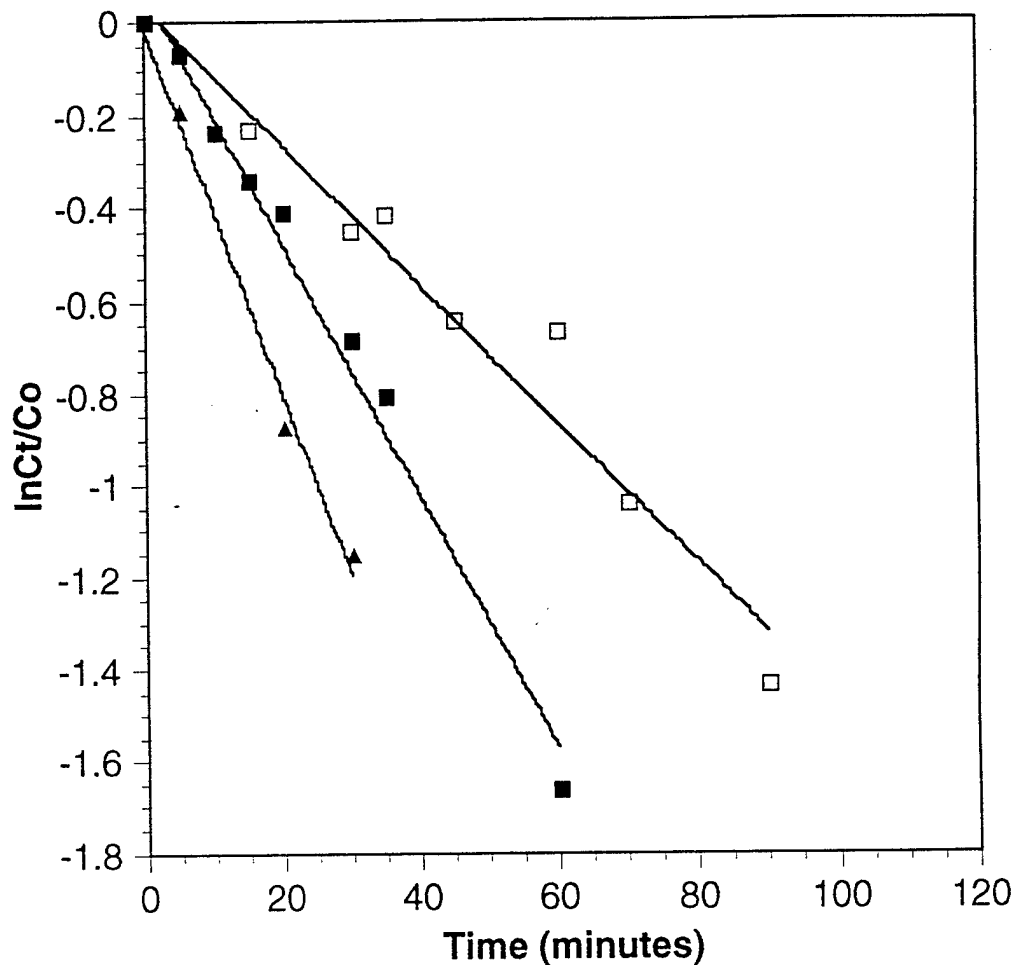

Figure 3.6 First-order disappearance plot for carbon tetrachloride in the presence of reduced cyanocobalamin immobilized on talc. Cyanocobalamin, 0.046 μmol ; Ti(III)citrate, 66 μmol ; 2 g talc; pH 7; incubated at 25 $^{\circ}\text{C}$ on a platform shaker. Closed triangles = dechlorination by reduced, unbound cyanocobalamin; closed squares = dechlorination by reduced, talc-bound cyanocobalamin; open squares = dechlorination by recycled talc-bound cyanocobalamin.

Chapter 4

Reductive Dehalogenation of Chlorinated Methanes by Iron Metal

Leah J. Matheson and Paul G. Tratnyek

Submitted to
Environmental Science & Technology

December 10, 1993

Abstract

Reduction of chlorinated solvents by fine-grained iron metal was studied in well-mixed anaerobic batch systems to assess the utility of this reaction in remediation of contaminated groundwater. Iron sequentially dehalogenates carbon tetrachloride, via chloroform, to methylene chloride. The initial rate of each reaction was pseudo-first-order in substrate and became substantially slower with each dehalogenation step. Thus, carbon tetrachloride degradation typically occurred in several hours, but no significant reduction of methylene chloride was observed over one month. Trichloroethene is also dechlorinated by iron, although more slowly than carbon tetrachloride. Increasing the clean surface area of iron greatly increased the rate of carbon tetrachloride dehalogenation, whereas increasing pH decreased the reduction rate slightly. The reduction of chlorinated methanes in batch model systems appears to be coupled with oxidative dissolution (corrosion) of the iron through a largely diffusion limited surface reaction.

Introduction

In the last few years, new interest in the reactions of reducing metals has been created by contemporary concerns with environmental protection, and an increasing number of research groups are working to access the utility of these reactions in treatment of contaminated materials. Most of the work reported to date has focused on reactor design. For example, Senzaki and coworkers [121, 122] reported extensive dehalogenation of 1,1,2,2-tetrachloroethane and trichloroethene by iron over a range of conditions in a variety of batch and column reactors. Subsequently they extended this work, showing that the rate of reduction could be increased by the amalgamation of iron with other metals, and that iron surface area seemed to have the greatest influence on the reaction rate [120]. A full-scale column reactor has been described by Sweeny [133, 134]. This device has been tested for treatment of industrial wastewaters using various combinations of Zn, Cu, Al, and Fe mixed with sand. Their systems were reported to dehalogenate trihalomethanes, chloroethenes, chlorobenzene, chlordane, and polychlorinated biphenyls (PCBs), as well as degrading atrazine, nitrophenols, and N-nitrosodimethylamine. Not all of these reactions were well documented, however, and it has been concluded by others that the apparent transformation of PCBs was due to sorption effects in the reactor column, rather than dechlorination [43].

Another approach to the use of iron metal in environmental remediation originated with a study of groundwater sampling techniques by Reynolds and coworkers [111]. These workers observed that halogenated hydrocarbon solvents were unstable in the presence of some commonly-used well casing materials. Further investigation of this effect indicated that most of the apparent degradation was due to dehalogenation and the reaction occurred in the presence of galvanized steel, stainless steel, aluminum, and iron. Since iron is relatively inexpensive and non toxic, it was proposed that it could be useful for the in situ remediation of contaminated groundwaters. Preliminary laboratory tests showed that industrial waste iron filings produced rapid and extensive reduction of dilute aqueous chlorinated solvents [52, 104]. On the basis of on these results, a pilot-scale field study was initiated consisting

of a permeable barrier, containing iron filings and sand, buried perpendicular to the path of an artificial plume of chlorinated hydrocarbons. During the year after installation, the barrier effectively reduced tetrachloroethylene and trichloroethylene as evidenced by a roughly stoichiometric increase in dissolved chloride, and identification of trace concentrations of dechlorination products [101].

The success of this field demonstration has attracted considerable attention to the possibility of remediating halocarbon-contaminated groundwaters by dehalogenation with granular iron. Both *in situ* reactive barriers and above-ground reactors are being developed for this purpose. However, the effective design and operation of these systems will be improved by a more detailed process-level understanding of iron/contaminant interactions in porous media. The purpose of our work in this area is to contribute to such an understanding. In this report we describe the mechanism and kinetics of transformations taking place in laboratory model systems containing low concentrations of chlorinated methanes in the presence of granular iron under anaerobic conditions. Further investigations are underway, by ourselves and others, to address additional transport, geochemical, and microbiological factors that may be important under environmental conditions.

Chemical Background

The redox couple formed by zero-oxidation state, metallic iron and dissolved aqueous Fe^{2+} , has a standard reduction potential of -0.440 V [20]



This makes iron metal a reducing agent relative to many redox-labile substances, including hydrogen ions, carbonate, sulfate, nitrate, and oxygen. Alkyl halides, RX , can also be reduced by iron. In the presence of a proton donor like water, they typically undergo reductive dehalogenation.

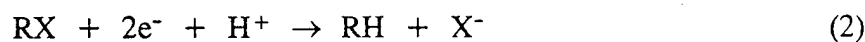

The estimated standard reduction potentials of this half-reaction for various alkyl halides range from $+0.5$ to $+1.5 \text{ V}$ at $\text{pH } 7$ [141]. Thus, the net reaction of eqs 1 and 2 is thermodynamically very favorable under most conditions.



The general reaction represented by eq 3 is a well-known member of a class of reactions known as dissolving metal reductions, which have been used in organic synthesis for over 140 years [61, 62].

The net reductive dehalogenation by iron (eq 3) is equivalent to iron corrosion with the alkyl halide serving as oxidizing agent. Since alkyl halides are widely used as solvents and lubricants, their interaction with industrial metals has been of considerable interest. For example, the effect of water on the corrosion of iron and steel by carbon tetrachloride was under investigation as far back as 1925 [112]. In a series of recent studies using a similar system, corrosion by 11 chlorinated alkanes and alkenes was compared in terms of weight loss of Al, Zn, and Fe [4, 6]. The reaction rate was found

to be greatest for saturated and *per*-halogenated organic oxidants, with most systems exhibiting accelerated reaction when water was present [5].

The characteristic reaction of iron corrosion (eq 1) results in oxidative dissolution of the metal at near neutral pH [69]. In the absence of strongly oxidizing trace constituents, there are two reduction half-reactions that can be coupled with eq 1 to produce a spontaneous corrosion reaction in water. Dissolved oxygen, when present, is the preferred oxidant (eq 4) resulting in rapid corrosion according to eq 5.

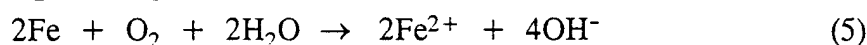
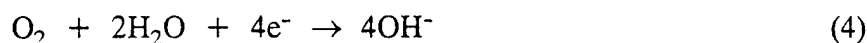

However, water alone can serve as the oxidant (eq 6) and, thus, corrosion occurs under anaerobic conditions according to eq 7.

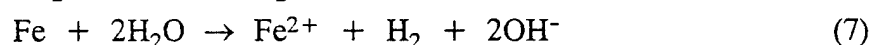

Both reactions (eqs 5 and 7) result in increased pH in weakly buffered systems, although the effect is more pronounced under aerobic conditions because they yield much more rapid corrosion. The pH increase favors the formation of iron hydroxide precipitates (Figure 4.1), which may eventually form a surface layer on the metal that inhibits its further dissolution.

The above discussion reveals that the three major reductants in an Fe-H₂O system are iron metal and the ferrous iron and hydrogen that result from corrosion. These reductants suggest three general pathways that may be available to contribute to dehalogenation of alkyl halides. The first pathway (Figure 4.2a), involves the metal directly, and implies that reduction occurs by electron transfer from the iron surface to the adsorbed alkyl halide. Thus, eq 3 alone would describe the reaction pathway.

The second pathway involves the Fe²⁺ that is an immediate product of corrosion by water (Figure 4.2b). Fe²⁺ is another reductant capable of causing dehalogenation of some alkyl halides, although these reactions are generally quite slow [37, 70].

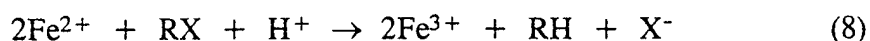

The importance of this process will probably be dictated by the ligands present in the system because speciation of ferrous iron significantly affects its strength as a reductant. Inner-sphere complexation of Fe^{2+} to metal oxide surfaces can also create more reducing species [132], but it is uncertain whether these species can significantly influence rates of dechlorination.

A third model for reductive dehalogenation by iron involves the hydrogen produced as a product of corrosion with water (Figure 4.2c).

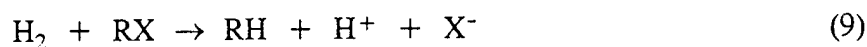

In the absence of an effective catalyst, H_2 is not a facile reductant and this reaction will not contribute directly to dehalogenation. In fact, excessive H_2 accumulation at the metal surface is known to inhibit the continuation of corrosion and of reduction reactions in organic synthesis. Rapid dehalogenation by H_2 is still possible, however, if an effective catalyst is available [61]. The surface of iron, its defects, or other solid phases present in the system could provide this catalysis. Determining the relative importance of these three dehalogenation pathways will be essential to predicting field performance of iron-based remediation technologies.

Experimental

Chemicals. Chlorinated solvents were obtained in high purity and used without further purification. These included carbon tetrachloride, HPLC grade (Aldrich); chloroform, LC grade, preserved with 1% (v/v) ethanol (Burdick & Jackson); methylene chloride, 99+%, anhydrous (Aldrich); chloromethane, 99.5+% (Aldrich); and trichloroethylene, 99+% (Aldrich). Saturated aqueous stock solutions of these halocarbons were prepared by allowing roughly 1 mL of organic phase to equilibrate with 40 mL of water in glass vials capped with Teflon Mininert valves. Aqueous standard solutions were made by diluting the saturated stock solutions with deionized water (NANOpure, 18 M Ω -cm).

The iron used in most experiments was an electrolytically-produced 100-mesh powder (Certified Grade, 95%, Fisher) with a nominal S content < 0.02%. Our own elemental analysis of the material measured < 10 ppm S, 1.3% C, and 0.3% N (expressed as their respective oxides). Prior to use, fines were removed by sieving with a 325-mesh screen (0.043 mm opening size). After acid pretreatment, the iron had a specific surface area \approx 0.7 m²/g. Other samples that were tested include "degreased" iron filings (Fisher and EM Science) and iron turnings (> 99.9%, Fluka).

Buffers were reagent grade and used as received (Sigma). These included 2-(N-cyclohexylamino)ethanesulfonic acid (CHES); N-(2-hydroxyethyl)piperazine-N'-(2-ethanesulfonic acid) (HEPES); 2-(N-morpholino)ethanesulfonic acid (MES); 3-(N-morpholino)propanesulfonic acid (MOPS); tris(hydroxymethyl)aminomethane (Trizma). Anaerobic solutions of all media were prepared by purging for roughly 1 hr with zero-grade N₂ that was deoxygenated by passing through a heated column of reduced copper.

Model Reaction Systems. Dechlorination experiments were performed in closed batch systems prepared in 60-mL serum bottles. In most cases, each bottle received 1 g of iron, weighed dry to the nearest mg. Oxides and other surface coatings

were removed by exposing the iron sample to 10 mL of 10% HCl for 1 hr and then rinsing three times with deoxygenated deionized water while purging the open bottle with N₂. Serum bottles containing acid-washed iron were filled completely with deoxygenated deionized water or appropriate buffer solution and crimp-sealed with Hycar stoppers (Pierce). No evidence for ferric oxide precipitation was found, even by optical microscopy. Loss of substrate to Hycar septa was less than 10% for carbon tetrachloride after 2 days, and 20% for chloroform, 10% for methylene chloride, and 25% for trichloroethylene after 17 days. Each bottle was allowed to equilibrate for 8-12 hr on a rotary shaker at 15 rpm (fixed orbit radius of 15 cm) in a dark, 15 °C room before addition of the substrate. A temperature of 15 °C was chosen for the dechlorination experiments to reflect common groundwater conditions.

To initiate a dechlorination experiment, 2 mL of saturated aqueous halocarbon stock solution was added by injection through the septum. A second needle was used to allow an equal volume of water to be displaced, so each dechlorination experiment began at 1 atm pressure with no headspace. Typical concentrations were 100-200 μM for carbon tetrachloride, 100-200 μM for chloroform, and 100-800 μM for methylene chloride. Reaction conditions were usually the same as those for the equilibration step described above. Loss of parent compound and production of dechlorinated product was determined by periodically removing 2 μL samples for immediate analysis using methods described below.

Analyses. Two chromatographic methods were used to determine the aqueous concentration of chlorinated solvents. Initial work employed purging with whole-column cryotrapping [106] with FID detection. However, most work was done by a modification of the method for direct aqueous injection on capillary columns developed by Grob [56]. Two microliter samples, taken directly from the reaction bottles, were injected via an on-column inlet at 92 °C, to a 2.5-m x 0.53-mm ID precolumn attached to a 30-m x 0.53-mm ID DB 624 analytical column (J&W) in an oven heated to 104°C. Satisfactory results were obtained with detection by FID. Peaks were identified by comparison with the retention times of standard compounds. A dedicated chromatograph for reducing gases was used to determine the concentration of H₂ produced by anaerobic corrosion (Trace Analytical).

A variety of techniques were used to characterize the iron samples used in this study. Total carbon, nitrogen and sulfur contents of the metal were determined using a

dedicated elemental analyzer by complete combustion with thermal conductivity detection (Carlo Erba NA-1500). The detection limit for sulfur (as SO_2) with this instrument was $10 \mu\text{g}/\text{mg}$ dry weight of sample. Iron surface area was determined by gas adsorption (Micromeritics, Gemini 2360) on samples that had been rinsed with methanol and dried under N_2 gas. Scanning electron microscopy was performed on a Zeiss 960 Digital SEM with elemental analysis by X-ray diffraction. The production of dissolved iron was quantified with the ferrozine method [50].

Determinations of pH before and after each experiment were made in open bottles with a gel-filled combination electrode. Measurements during an experiment were made through the septum with an 18 gauge, beveled tip combination electrode (Microelectrodes, Inc.). Two-point calibrations were performed daily at pH 4.00 and 7.00 using commercial buffers. Eighteen-gauge needle-form combination electrodes (Microelectrodes, Inc.) were also used to measure redox potential. The platinum element was conditioned in dilute nitric acid and the electrode performance was verified in a solution of iron ammonium sulfate [82]. Electrode potential was measured in the sealed serum bottles and is reported in volts versus the standard hydrogen electrode (SHE).

Results and Discussion

Corrosion in Fe-H₂O Model Systems. About 15% of the iron used to start each experiment was lost by corrosion during the acid pretreatment step. Corrosion continued after rinsing the iron and reconstituting the system at circum-neutral pH. However, iron dissolution was much slower under these conditions, as evidenced by the lack of measurable decrease in iron by weight and the production of < 400 µg/L Fe²⁺. The concentration of H₂ increased to > 400 mg/L within 1 hr, confirming that anaerobic corrosion was taking place by reduction of water (Eq 7). The pH did not increase significantly, suggesting that the hydroxide produced by water reduction was balanced by other processes, perhaps formation of iron hydroxides.

Measured Pt electrode potential in the solution decreased rapidly after the system was sealed and mixed. After the initial rapid decline, the potential continued to decrease but much more slowly. This decrease continued throughout the pre-incubation period to a value of approximately -300 mV (vs. SHE). The trend reflects a gradual dissolution of iron to give Fe²⁺ (Figure 4.1). Ferrous iron has a large exchange current with Pt and is undoubtedly the dominant electrode-active species in this system. When carbon tetrachloride was added through the septum, the electrode potential increased sharply, by about 100 mV, but then declined rapidly to its prior value.

The 8-12 hr equilibration period between set-up and initiation of dechlorination experiments was intended to ensure that our model systems reflect the behavior of iron in long-term field applications and not initial adjustments in conditions like the rapid decrease in electrode potential described above. However, dechlorination rates were generally the same whether the substrate addition was made immediately after set up, or after the pre-incubation period of approximately 8 hours.

Halocarbon Degradation Pathways. There are several general reaction types available for cleaving the carbon-halogen bonds that characterize many environmental contaminants. These include nucleophilic substitution by water or hydroxide

(hydrolysis) or by sulfide or thiols; β -elimination of HX (dehydrohalogenation); gem-elimination yielding products via a carbene intermediate; reductive elimination of adjacent halogens leaving an unsaturated product (vicinal dehalogenation); reduction of a single C-X bond to a C-H bond (reductive dehalogenation, eq 2); and oxidation to carbonyl products [78, 142, 144]. The relative rates of these processes will vary with substrate, and chemical and microbiological conditions. Halogenated methanes are not subject to dehydrohalogenation or vicinal dehalogenation, and hydrolysis of these compounds is very slow under most conditions [68]. Carbon tetrachloride was chosen as the primary substrate for this study, in part, to be able to focus on reductive dehalogenation in the presence of iron. Many previous studies have used carbon tetrachloride as a model system with which to study the reductive dehalogenation as an environmental pathway [32, 72].

Carbon tetrachloride was degraded by reductive dehalogenation to chloroform in all laboratory model systems containing iron metal. Mass balance based on the appearance of chloroform typically accounted for about 70% of the carbon tetrachloride lost (Figure 4.3a). After the carbon tetrachloride concentration had decreased to the detection limit, methylene chloride was observed from further reductive dehalogenation of chloroform (Figure 4.3b). Mass balance for appearance of methylene chloride from chloroform was typically about 50%. Methylene chloride disappearance was only apparent after several months, and it was not possible to unequivocally demonstrate that this was a result of dechlorination. No formation of chloromethane, methane, or coupling products like hexachloroethane was detected. These results indicate that the dominant degradative pathway for chlorinated methanes in anaerobic Fe-H₂O systems is sequential reductive dehalogenation, and that this reaction becomes much less favorable with each successive dechlorination step. A few similar experiments were performed with trichloroethylene as substrate. Trichloroethylene was degraded, but the products of this reaction were not investigated.

Kinetics of Transformation. In well-mixed systems, plots of the natural logarithm of substrate concentration versus time for carbon tetrachloride and chloroform gave straight lines from their initial concentrations to their respective minimum detection limits (1-3 half-lives, typical $r^2 > 0.95$ for $n = 5-10$). From this, it was concluded that the kinetics of these reactions are pseudo-first-order in substrate, and that the various possible changes in the system—due to the simultaneous corrosion

of iron—do not significantly effect dechlorination rates over the duration of our experiments. The slope of lines regressed to natural logarithm of concentration versus time data were used to obtain first-order rate constants, k_{obs} , in most of the experiments reported below. However, to illustrate the entire time-course of one experiment, the data in Figure 4.3 have been fit by nonlinear regression to the integrated rate laws for sequential first-order reactions [27]

$$[\text{CCl}_4]_t = [\text{CCl}_4]_{\max} e^{-k_1 t} \quad (10)$$

$$[\text{CHCl}_3]_t = \frac{[\text{CHCl}_3]_{\max} k_1}{k_2 - k_1} (e^{-k_1 t} - e^{-k_2 t}) \quad (11)$$

$$[\text{CH}_2\text{Cl}_2]_t = [\text{CH}_2\text{Cl}_2]_{\max} (1 - e^{-k_2 t}) \quad (12)$$

where k_1 is the first-order rate constant for dechlorination of carbon tetrachloride to chloroform, and k_2 is the rate constant for conversion of chloroform to methylene chloride. The results of these calculations are presented in Table 4.1. The disappearance rate constant for carbon tetrachloride corresponds to a $t_{1/2} = 15$ min, which is typical of unbuffered experiments run at 15 rpm using 1.00 g of acid-washed Fisher electrolytic iron. Under these conditions, chloroform disappearance occurs with $t_{1/2} \approx 3$ days and methylene chloride is not measurably degraded. Note that the concentration of chloroform in Figure 4.3 reflects both dehalogenation from carbon tetrachloride to chloroform, and subsequent dechlorination of chloroform to methylene chloride. The differences between the corresponding parameters in Table 4.1 are consistent with incomplete mass balances at each dechlorination step, as described above. The rate of trichloroethylene disappearance in our model system was first-order in substrate concentration with a $t_{1/2} = 30$ -40 days (data not shown).

Pathway of Dechlorination by Iron. As illustrated in Figure 4.2, the presence of iron metal, Fe^{2+} , and H_2 in anaerobic $\text{Fe-H}_2\text{O}$ systems provides three possible reducing agents capable of affecting dehalogenation. A variety of control experiments

and treatment studies were performed to help identify which of these reductants is the most important contributor to transformation of carbon tetrachloride, and the results are summarized in Table 4.2. Uncatalyzed reduction by dissolved H_2 or Fe^{2+} can be excluded on the basis of control experiments: neither H_2 -saturated water nor 5-100 mg/L $FeCl_2$ produced measurable dehalogenation over 15 days in the absence of the metal. It is difficult to exclude the possibility that adsorbed Fe^{2+} , or nascent hydrogen that results from reduction of water at the iron surface, may be participating in the dehalogenation reaction. However, amendment of Fe- H_2O systems with additional Fe^{2+} or H_2 did not effect the rate of carbon tetrachloride dehalogenation in a significant or systematic manner. In addition, 0.5 mM EDTA, which should form a redox-inactive complex with Fe^{2+} produced by corrosion [26], had no effect on the carbon tetrachloride dehalogenation rate. Taken together, the data in Table 4.2 suggest that reductive dehalogenation directly coupled with oxidative dissolution of the metal (Figure 4.2a) is the dominant process under conditions employed in this study.

Effect of pH. Understanding dehalogenation by iron as reduction of the halocarbon coupled with oxidative dissolution of the metal suggests several ways in which pH may influence the reaction rate. The requirement for H^+ participation in the overall reaction (eq 3), suggests the possibility that protons may appear in one or more elementary steps that influence the reaction rate directly. In addition, strong indirect effects are possible due to increased aqueous corrosion at low pH or iron hydroxide precipitation at high pH. Our early experiments showed that unbuffered systems consistently gave pH values of 7.5 to 8.0 and that changes during the course of carbon tetrachloride dehalogenation experiments were small: pH typically decreased by less than one unit. Since this modest variability in pH did not appear to be effecting dehalogenation rates, most experiments were done without added buffer.

To determine the carbon tetrachloride dehalogenation rate over a wide range of pH, a series of buffered systems was needed. Good's buffers were used because they interact weakly with most metals in solution [54], and preliminary tests gave no visual evidence for precipitation with iron over the duration of a typical experiment. Five of these buffers, with overlapping pH ranges, were used to obtain data from pH 5.5 to 10.0 (Table 4.3). The values of k_{obs} decreased with increased pH and the trend showed no inconsistencies attributable to individual buffers (Figure 4.4). In addition, unbuffered systems gave dehalogenation rates consistent with buffered systems at

similar pH values. The effect of pH on k_{obs} is apparently linear; giving a least-squares regression line of

$$k_{\text{obs}} = -0.018(\pm 0.001) \text{ pH} + 0.20(\pm 0.01) \quad (13)$$

with $r^2 = 0.92$ for $n = 16$. The slope of this line has been useful for estimating the potential significance of pH variability on observed dehalogenation rates. A plot of $\log k_{\text{obs}}$ vs. $\log [\text{H}^+]$ also gives a linear relationship ($r^2 = 0.91$, $n = 15$, figure not shown) but, in this case, the slope is the empirical order of reaction with respect to concentration of H^+ . Fitting the data gives a reaction order of 0.14 ± 0.10 . This low value indicates that H^+ is not involved in a single rate-determining step in the dehalogenation mechanism. It is, however, consistent with the indirect effects proposed above, or with a mixture of concurrent effects.

Role of Iron Surface Characteristics. The direct role of iron as a reactant in eq 3 implies the involvement of reactive sites on the metal, and, therefore, that the condition and quantity of metal surface in a reaction system should strongly influence the rate of dehalogenation. Early experiments showed that preceding each experiment by rinsing the metal in dilute aqueous HCl produced faster dechlorination, and that this pretreatment was necessary to obtain any appreciable reaction at all for some iron samples. Treating the iron in this way presumably provides a well defined and reproducible surface [6, 152], so it was applied to most experiments as a standard procedure.

The most likely explanation for the effect of acid washing is that it dissolves the surface layer on the iron grains, leaving clean reduced metal that is relatively free of unreactive oxide or organic coatings. Increased iron surface area due to corrosion pits may also contribute to the greater reactivity of halocarbons with acid-washed iron. However, scanning electron microscopy of the iron grains, before and after treatment with acid, showed little increase in the density of corrosion pits. Similarly, the enhanced dechlorination of acid-washed iron can not be attributed to the effect of pH on the dehalogenation rate, because pH measurements gave no evidence for residual acidity due to the acid wash procedure.

Besides pretreatment of iron with acid, the most significant experimental variable influencing k_{obs} for dehalogenation was the amount of iron available to react

with the organic substrate. Figure 4.5 illustrates this relationship in terms of two parameters: grams of iron per liter of reaction volume, which is operationally the most convenient, and m^2 of surface area per liter, which should incorporate most of the effects of grain size and shape. The relationship appears to be linear and regression of k_{obs} (min^{-1}) versus surface area concentration (m^2/L) gives

$$k_{\text{obs}} = 0.0025(\pm 0.0002) [\text{Fe Surface Area}] + 0.017(\pm 0.005) \quad (14)$$

with $r^2 = 0.96$ for $n = 8$. The concentration of iron surface area was calculated from an average specific surface area for the iron used in this experiment ($0.7 \text{ m}^2/\text{g}$) and the mass of iron remaining after dechlorination. The robustness of eq 14 is evidenced by how well it correlates the results of a subsequent experiment in which both mass of iron and total reaction volume were varied (Table 4.4, Figure 4.5). However, the broader utility of eq 14 will be limited by the uncertain relationship between surface area determined by gas adsorption on dry samples and the concentration of accessible and reactive sites on a hydrated metal surface [126, 140]. In principle, dye adsorption from aqueous solution is an alternative method for determining surface area that should offer substantial advantages for use in our systems. Unfortunately, preliminary results with this method appeared to be unreliable, and no other promising alternative to the BET method has been identified.

Kinetics of Surface Reaction. Since dehalogenation apparently occurs at the Fe/ H_2O interface, transport as well as reaction steps must be involved. A general model for surface reactions consists of five steps [126, 130, 132]: (i) mass transport of the reactant to the iron surface from the bulk solution; (ii) adsorption of the reactant to the surface; (iii) chemical reaction at the surface; (iv) desorption of the product(s); and (v) mass transport of the product(s) to the bulk solution. Any one or a combination of these steps may be rate limiting and, therefore, determine the values of k_{obs} obtained in this study. To properly interpret trends in reaction rate, it is especially important to distinguish between transport- and reaction-limited kinetics.

A common criterion for detecting mass transport limited kinetics is variation in reaction rate with intensity of mixing. Rates that are controlled by a chemical reaction step should not be affected, whereas aggressive mixing usually accelerates diffusion-controlled rates by reducing the thickness of the diffusion layer at particle surfaces

[126]. Batch experiments in this study were mixed by 360° rotation around a fixed-length axis, so the practical measure of mixing intensity is rpm. Figure 4.6 shows that k_{obs} for carbon tetrachloride reduction increased with rotation rate up to about 50 rpm. This trend suggests that mass transport is an important contributor to the kinetics of dechlorination under the conditions employed in this study. Limitations in the method of mixing did not allow a condition to be reached where mass transport was unimportant and k_{obs} was constant. Due to the uncertain form of the relationship between k_{obs} and rpm, regression has not been performed on the data. However, the trend in Figure 4.6 shows the importance of mixing as an experimental variable in batch studies of dehalogenation by iron.

Additional support for the importance of mass transport to the kinetics of dehalogenation in our systems comes from the effect of temperature on k_{obs} . Reaction rates that are limited by diffusion typically have low activation energies and, therefore, a weak dependence on temperature relative to rates that are limited by a chemical reaction step [126]. Our data (not shown) indicate that k_{obs} is unaffected by temperature over the range from 4 to 35 °C, and fitting the data to the Arrhenius equation gives a slope that is not significantly different from zero. The practical implication of this result is that temperature control was not considered to be an important experimental variable, even though we performed most experiments at a typical groundwater temperature of 15 °C.

Mechanism of Dehalogenation. A thorough mechanistic study on the dehalogenation of alkyl halides in dilute aqueous solution by the presence of iron or other reducing metals does not appear to have been reported. However, a mechanistic context for our observations can be proposed based on the results of previous work done on a variety of related systems.

Numerous studies have shown that dissociative adsorption of H₂O takes place at clean iron surfaces, resulting in surface-bound hydroxyl, atomic oxygen, and atomic hydrogen [14, 63, 136]. The latter species—sometimes called “nascent” hydrogen—can combine with itself, accounting for the formation of H₂, or react with other compounds in the system, resulting in their hydrogenation. Adsorbed atomic hydrogen is the species that is directly responsible for many important catalytic hydrogenation reactions [62], and it has been invoked as an intermediate in the mechanism of dissolving metal reductions [21, 61]. However, dissolving metal reductions may also occur by direct

electron transfer between the metal and the absorbed organic substrate. A debate over the relative importance of these two mechanisms has gone on for many years, but the electron transfer model is generally preferred to explain reductions at the surface of metals with highly cathodic overpotentials (e.g., Fe or Zn as opposed to Pt or Pd) [21, 61, 136].

The direct reduction mechanism requires adsorption of the organic substrate on the metal surface and electron transfer. Most studies of electron transfer to alkyl halides suggest that this is a concerted, dissociative process that results in the formation of a carbon-centered radical, R^\bullet [39, 64, 147].



Presumably, the electron is transferred into the lowest unoccupied (σ^* antibonding) orbital of the substrate molecule [28, 147]. Although the first electron transfer is rate limiting in many organic reduction reactions, this does not appear to have been the case under the conditions of this study. The initial step in corrosion of aluminum by neat chlorinated solvents is also represented by eq 15, but it has been described in different terms: as charge transfer from the metal to the halogen of the adsorbed substrate, with associated homolytic cleavage of the halogen-carbon bond [4, 5, 6]. Adsorption of halocarbons from the gas phase onto iron surfaces is also known to occur by a dissociative mechanism, resulting in dechlorinated radicals as intermediate products [57, 124].

Once formed, the radical may react to give final products in a variety of ways. In the absence of a good proton donor, dimerization of the radical can be important, especially where the halocarbon is abundant because it is also the primary solvent [6, 129]. Dimerization is not favored in dilute aqueous systems, which is consistent with the lack of hexachloroethane formation from carbon tetrachloride reduction in this study. Instead, the radical undergoes a second electron transfer and protonation, which results in the reductive dehalogenation products that we observed to be predominant.



Although the rate of this step may strongly influence the observed distribution of reduction products, the reaction represented by eq 16 has received less investigation than the radical formation step (eq 15). As a result, fewer generalizations can be made

about the expected effects of conditions on its rate and mechanism. For example, proton availability will certainly effect eq 16, but there is considerable uncertainty over the relationship between proton availability at the metal surface and bulk pH [28]. Such distinctions may prove to be important in describing the effectiveness of iron at dehalogenating contaminants under environmental conditions.

By analogy to the mechanism of aqueous corrosion of iron [14], the half-reaction that accompanies the first electron transfer to a halocarbon (eq 15) is presumably oxidation of surface Fe to Fe^{1+} . Subsequent electron transfers provide for formation and dissolution of Fe^{2+} . However, corrosion is often formulated as an electrolytic phenomenon, where the reduction half-reaction occurs at a cathodic site, oxidation at an anodic site, and the two are balanced by conduction through the metal and the electrolyte [69]. In highly conductive media, macroscopic separation of these sites is well known, but an electrolytic corrosion mechanism in nonionic solvent systems can only occur if site separation is very small, on the order of angstroms, as was proposed in an early study on aluminum corrosion by boiling carbon tetrachloride [23]. Others have argued that aluminum corrosion in 1,1,1-trichloroethane is not electrolytic [4] but that the oxidation and reduction half-reactions occur at the same site: i.e., without separation of anode and cathode. It is generally assumed that dissolving metal reductions, even in aqueous systems, occur without separation of anodic and cathodic sites [61]. This distinction could have practical significance in the context of this study, if site separation leads to extensive pitting of the metal. However, inspection of iron surfaces by scanning electron microscopy after one of the dechlorination experiments showed very little pitting, and therefore suggests predominantly uniform corrosion.

Conclusion

Carbon tetrachloride and chloroform undergo rapid reductive dehalogenation in the presence of fine-grained iron metal. With each successive dehalogenation, the reaction proceeds more slowly, and methylene chloride is not significantly degraded over the time scales of our experiments. Relative product distributions vary with conditions, however, so it is possible that circumstances may exist that allow significant degradation of methylene chloride will occur. Degradation of trichloroethylene was also observed, but the mechanism of this reaction was not investigated.

In the closed model systems, the overall chemistry of the system is dominated by anaerobic corrosion; i.e. oxidative dissolution of Fe to Fe^{2+} . The chloromethanes apparently substitute for water in this reaction, providing an alternative oxidant for the iron metal, and a mechanism has been proposed involving direct electron transfer to the adsorbed halocarbon. Dehalogenation of carbon tetrachloride was faster at more acidic pH, but this effect was modest. Additional effects are possible under other conditions. For example, aerobic systems may behave differently due to more aggressive corrosion and the precipitation of ferric hydroxides; sulfide, where it occurs in groundwater, will significantly influence the redox chemistry of iron and probably also the fate of chlorinated contaminants; and bacteria could be important due to microbial dehalogenation, biocorrosion, Fe^{2+} oxidation, or Fe^{3+} reduction.

Under the conditions of our experiments, mass transport of substrate to the iron surface appeared to be an important determinant of dechlorination rate, so it was important to control mixing as an experimental parameter. The most important predictor of dechlorination rate was the iron surface area concentration. Even during environmental application it is likely that access to, condition and concentration of the iron surface are the dominant factors controlling remediation performance.

Table 4.1 Kinetics of Carbon Tetrachloride Disappearance.^a

RX	[RX] _{max} (μM)	<i>k</i> ₁ (min ⁻¹)	<i>k</i> ₂ (min ⁻¹)
CCl ₄ (Eq 10)	151 ± 5	0.045 ± 0.003	
CHCl ₃ (Eq 11)	107 ± 1	0.032 ± 0.005	1.41 ± 0.03 × 10 ⁻⁴
CH ₂ Cl ₂ (Eq 12)	53 ± 18		1.6 ± 0.9 × 10 ⁻⁴

^a Experiment performed at 15 °C and 15 rpm using 1.00 g iron. Uncertainties are one sd in the fitted parameter from nonlinear regression.

Table 4.2 Effects of Treatments on the Rate of Reductive Dehalogenation for Carbon Tetrachloride.^a

Fe (g)	FeCl ₂ (mg/L)	H ₂ (psi)	EDTA (mM)	<i>k</i> _{obs} (min ⁻¹) ^b
1.00			0	0.062
1.00		10	0	0.083
1.00	5		0	0.037
1.00	50		0	0.049
1.00	100		0	0.024
1.00	100		0.5	0.030
1.00			0.5	0.061
0		10	0	ND ^c
0	100		0	ND ^c
0	100		0.5	ND ^c

^a Conditions: unbuffered pH ≈ 7, 15 °C, 15 rpm, 100-mesh sieved Fisher electrolytic iron.

^b Uncertainties from the regression lines are <0.008 min⁻¹ (±1 sd) for all cases.

^c No detectable loss.

Table 4.3 Kinetics of Carbon Tetrachloride Disappearance in Buffered Systems.^a

Fe (g)	pH	Buffer type	k_{obs} (min ⁻¹) ^c
1.00	6.5 ^b	MOPS	0.083
1.00	7.4	MOPS	0.067
1.00	8.2	MOPS	0.041
0	7.4	MOPS	0
1.00	6.4 ^b	HEPES	0.080
1.00	7.5	HEPES	0.060
1.00	8.2	HEPES	0.047
0	7.5	HEPES	0
1.00	5.5 ^b	MES	0.100
1.00	6.0 ^b	MES	0.088
1.00	6.6 ^b	MES	0.083
0	6.0	MES	0
1.00	8.6	CHES	0.037
1.00	9.0	CHES	0.036
0	9.5	CHES	0.037
1.00	10.0	CHES	0.026
0	9.0	CHES	0
1.00	7.2	TRIZMA	0.077
1.00	8.0	TRIZMA	0.053
1.00	9.0	TRIZMA	0.018
0	8.9	TRIZMA	0

^a Conditions: 15 °C, 15 rpm, 100-mesh sieved Fisher electrolytic iron, 50 mM buffer.

^b pH decreased due to rapid corrosion despite buffer.

^c Uncertainties are <0.01 based on slope the regression line.

Table 4.4 Effects of Iron Loading on the Rate of Reductive Dehalogenation for Carbon Tetrachloride.^a

Fe before (g)	Fe after (g) ^b	Volume (L)	Surface Area (m ² /L) ^c	k_{obs} (min ⁻¹) ^d
0.50	0.404	0.06	4.71	0.027
1.00	0.870	0.06	10.15	0.047
1.00	0.820	0.06	9.57	0.039 ^e
1.00	0.814	0.11	5.18	0.029 ^e
1.00	0.831	0.16	3.64	0.010 ^e
1.50	1.286	0.06	15.00	0.053
2.00	1.748	0.06	20.39	0.061
2.00	1.710	0.06	19.95	0.067 ^e
2.00	1.641	0.11	10.44	0.041 ^e
2.00	1.695	0.16	7.42	0.037 ^e
2.50	2.196	0.06	25.62	0.085
2.50	2.196	0.06	25.62	0.085
3.00	2.647	0.06	30.88	0.088
3.00	2.647	0.06	30.88	0.099

^a Conditions: unbuffered pH \approx 7, 15 °C, 15 rpm, 100-mesh sieved Fisher electrolytic iron.

^b Weight at end of dechlorination experiment.

^c Calculated for a specific surface area = 0.7 m²/g.

^d Standard deviations of the slope of first-order regression lines are $<$ 0.007 min⁻¹.

^e Data not included in the regression line (eq 14).

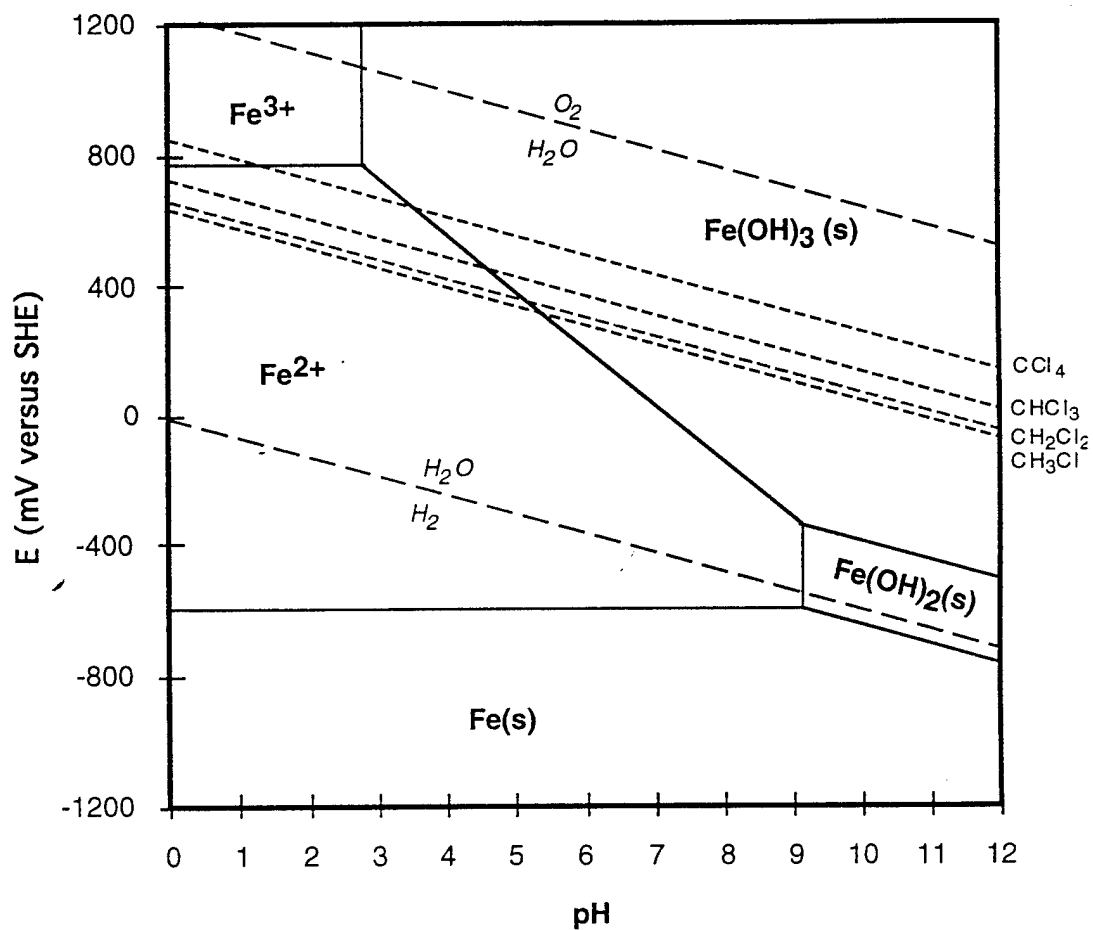

Figure 4.1 Pourbaix diagram for the Fe-H₂O system under conditions typical of this study: $Fe_T = 0.076$ mM, $\{Cl\} = 0.001$, and 15 °C. Lines for halomethane redox couples are based on potentials in [141].

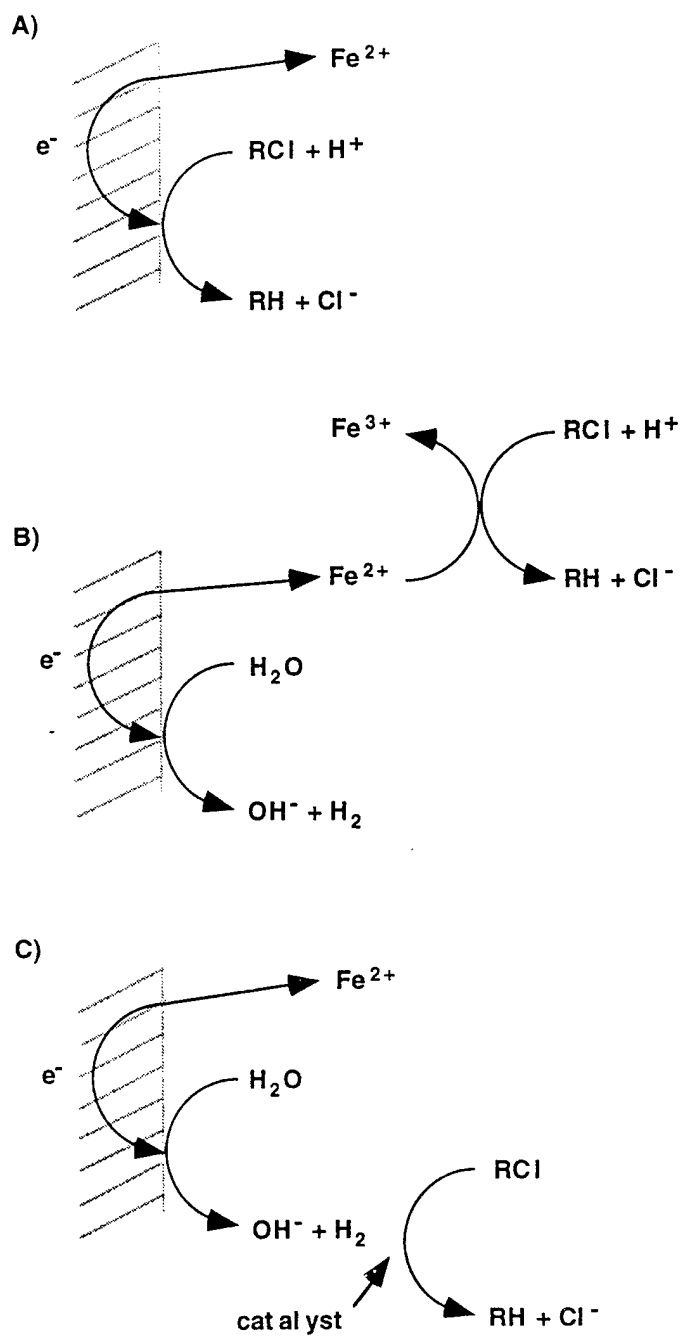

Figure 4.2 Scheme showing proposed pathways for reductive dehalogenation in anoxic Fe-H₂O systems: A) direct electron transfer from iron at the metal surface; B) reduction by Fe²⁺, which results from corrosion of the metal; C) catalyzed hydrogenolysis by the H₂ that is formed by reduction of H₂O during anaerobic corrosion. Stoichiometries are not shown.

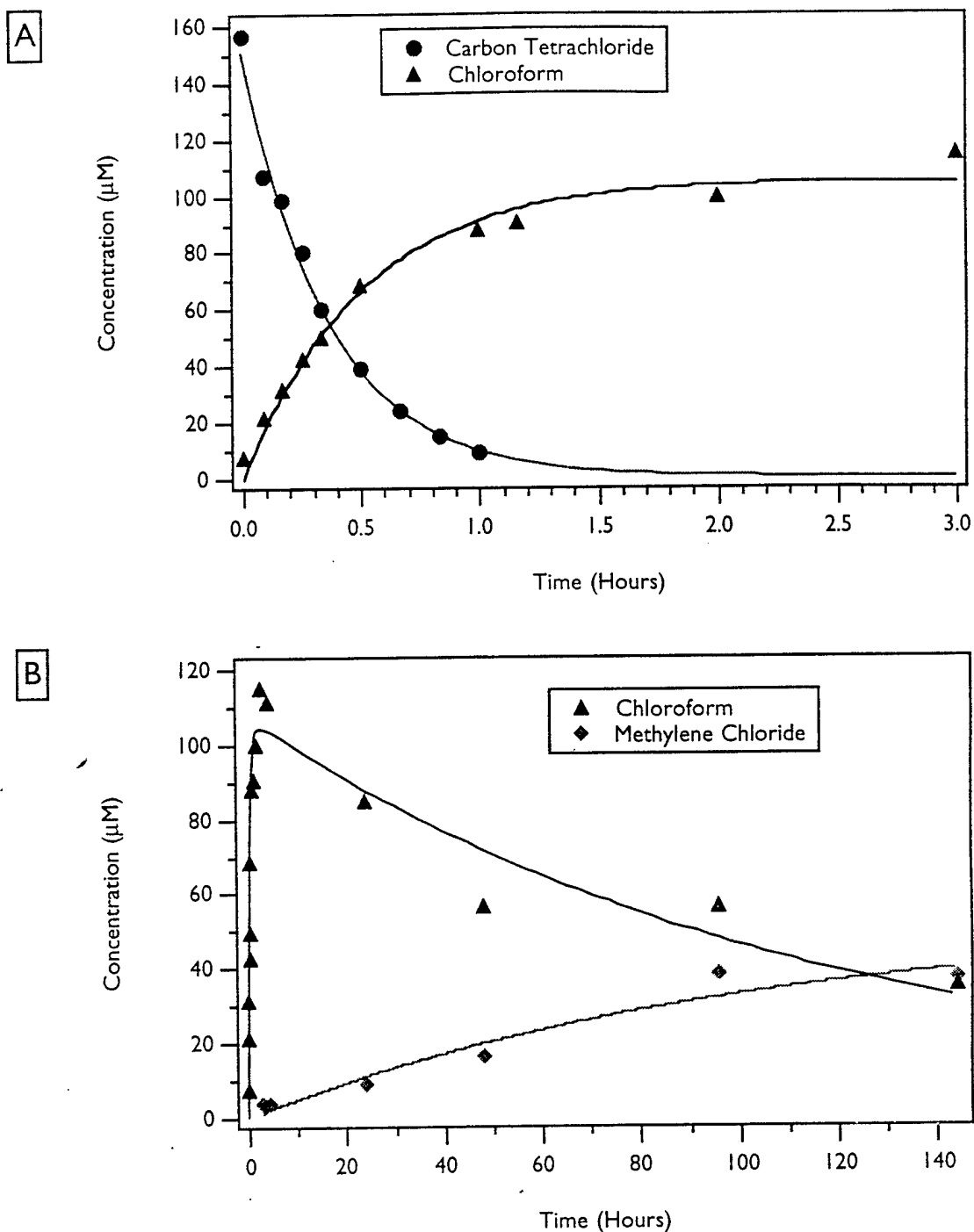

Figure 4.3 Disappearance of a) carbon tetrachloride with the appearance of chloroform, and b) subsequent disappearance of chloroform with appearance of methylene chloride. System: 1 g of iron, unbuffered pH 8.0, and 15 °C.

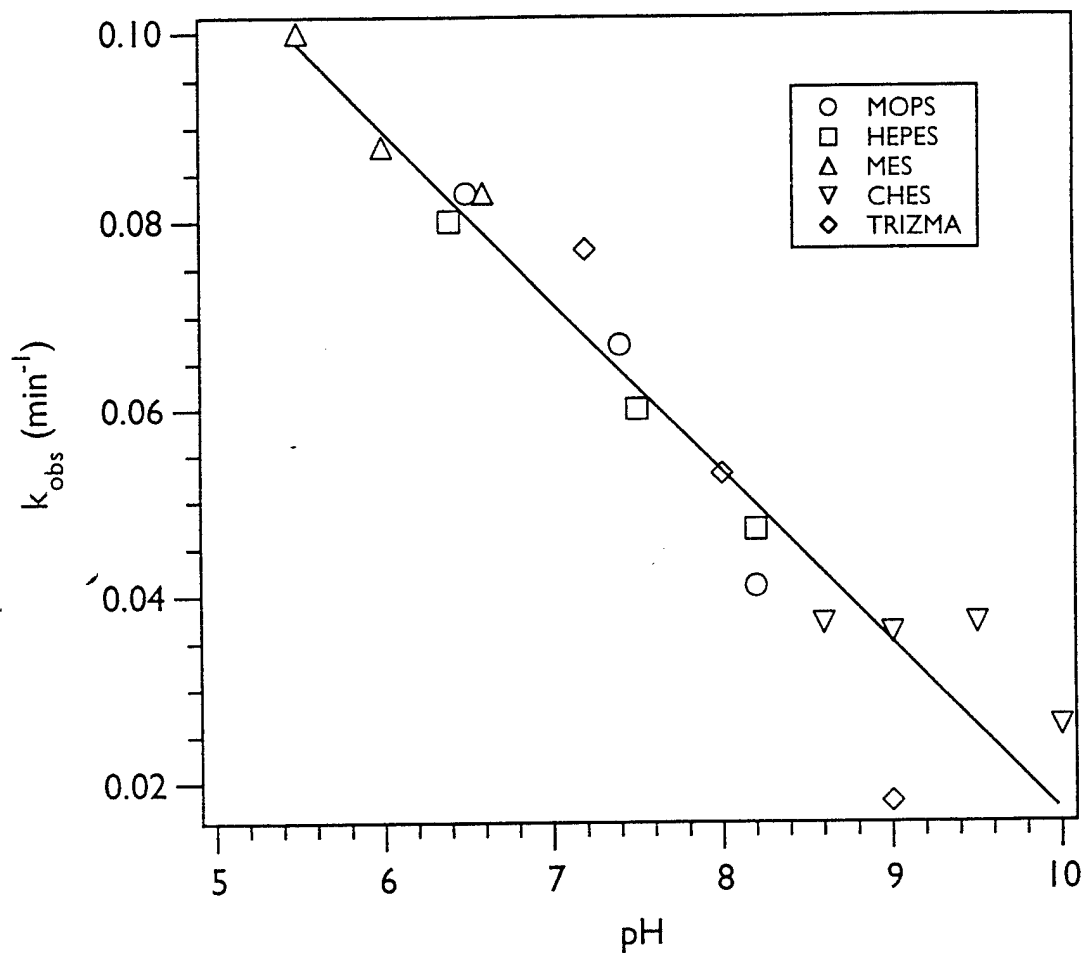

Figure 4.4 The effect of pH on the pseudo-first-order rate constant for carbon tetrachloride dehalogenation by iron. Good's buffers were used. Each bottle contained 1 gram Fisher iron powder, was mixed at 15 rpm and incubated at 15 °C. Regression line corresponds to eq 13.

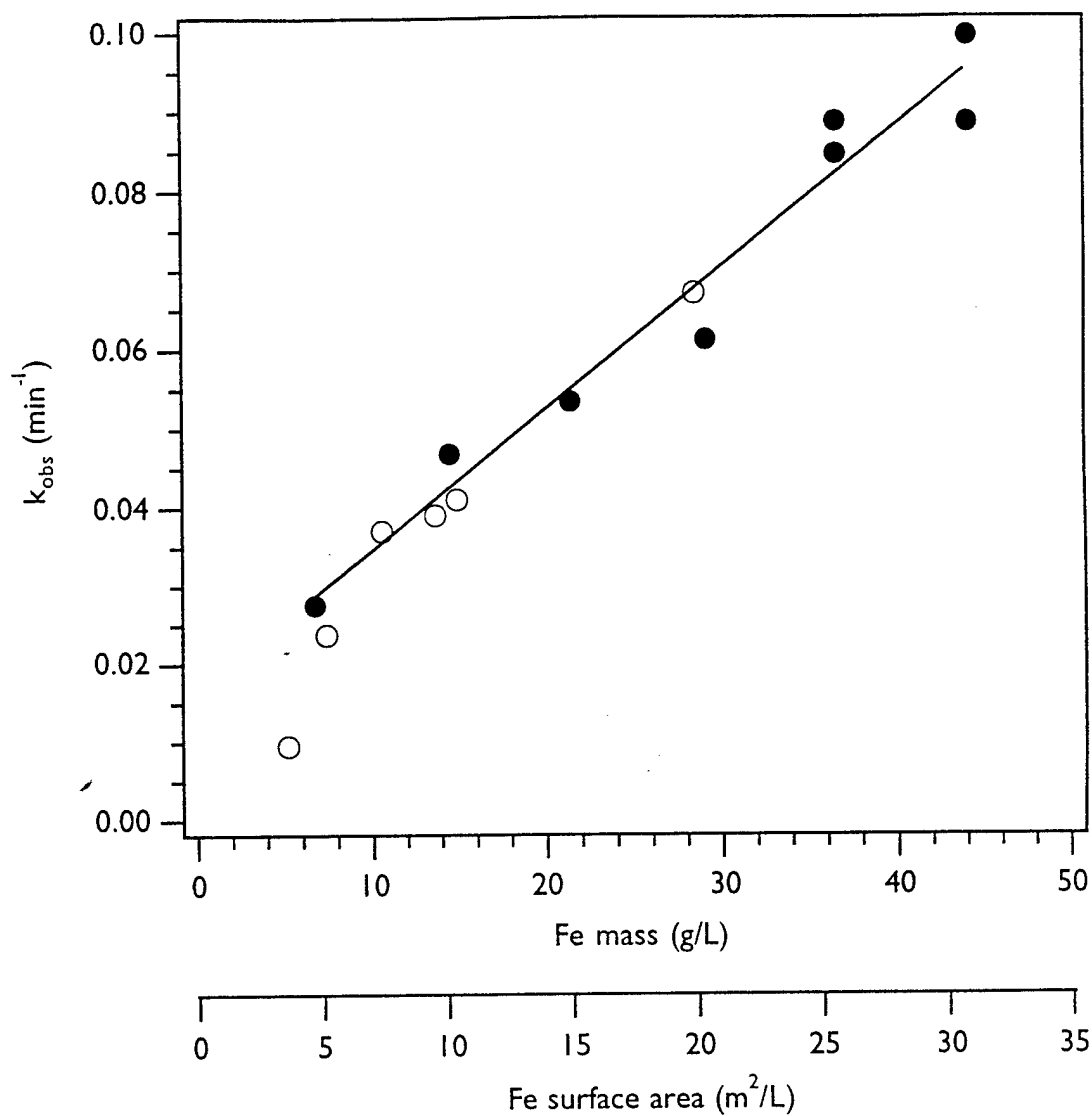

Figure 4.5 The effect of surface area on pseudo-first-order rate constants for carbon tetrachloride dehalogenation. Iron loadings varied, as shown in Table 4.4. The systems were unbuffered mixed at 15 rpm and incubated at 15 °C. Regression line corresponds to eq 14. Solid circles are the fitted data, open circles are data collected in a subsequent experiment to validate the results with respect to variation in reaction volume.

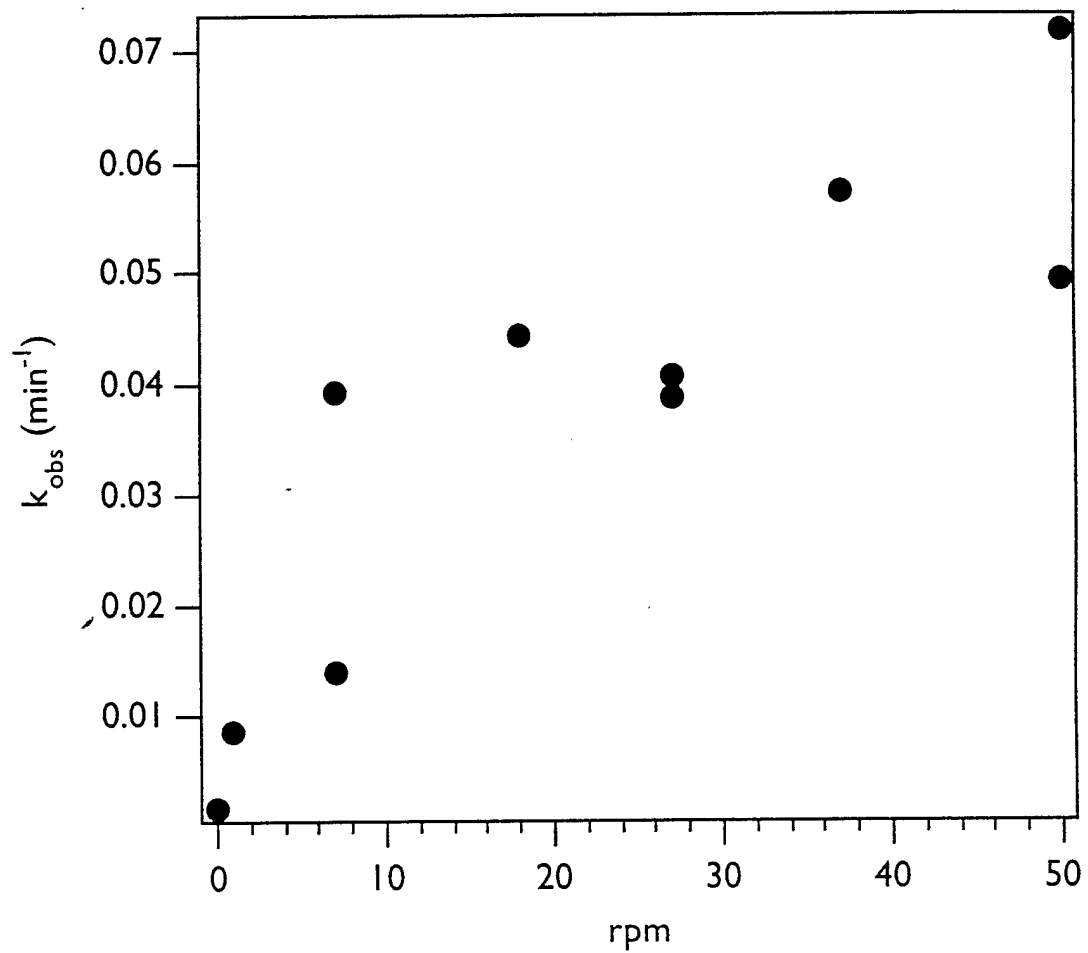

Figure 4.6 The effect of mixing rate on pseudo-first-order rate constant for carbon tetrachloride dehalogenation by iron. All contained 1g Fisher iron powder, were unbuffered, and incubated at 15 °C.

Chapter 5

Microbial and Geochemical Processes Affecting Reductive Dehalogenation by Iron Metal in the Environment

Leah J. Matheson, Paul G. Tratnyek and David R. Boone

Abstract

Core samples from an in-ground, permeable, Fe barrier were obtained one and two years after its construction, and were studied for microbiological and geochemical developments that might affect remediation performance. Analysis of the metal surfaces by scanning electron microscopy showed that the morphology of the iron grains had not changed significantly from the morphology of the original iron material used. Elemental analysis by X-ray diffraction of the iron grains did not reveal the presence of any elements other than iron and small amounts of silica. No sulfur compounds were detected by this technique, or by CNS analysis. The cores were tested for the presence of selected microbial populations, of which only low numbers of sulfate-reducing bacteria were observed in both one and two year cores. No other obvious microbial activity such as colonization, biopolymer or slime production was observed in either set of cores. Microbial enrichments for dehalogenating activity were negative. In general, the core samples had lower microbially activity than was originally suspected. This lack of microbial activity may be due to the low concentration of dissolved organic matter at the site. The ferrous iron and hydrogen produced from the corroding iron, in addition to sulfate present at the site, may create favorable conditions down gradient from the Fe zone for microorganisms that utilized these compounds as electron donors and acceptors.

Introduction

Background. Iron metal, Fe, can rapidly dehalogenate a variety of organic substances that are important environmental contaminants (Chapter 4). Laboratory experiments and several field demonstrations have shown that this process may be used effectively for remediating contaminated groundwaters. The previous chapter described laboratory batch experiments that were carried out to gain a better understanding of the mechanism and kinetics of dechlorination by Fe. However, field conditions may differ from those of simple laboratory systems in several important ways and geomicrobial effects are expected to have an influence on the *in situ* reduction of pollutants by iron. The geomicrobial conditions encountered in the field that might affect dechlorination by iron include natural substances in groundwater (e.g. HS⁻), microorganisms, cocontaminants and mixed-waste systems, and impurities introduced with the iron (such as cutting oils and greases).

The herein reported studies focused on microbial and geochemical effects of Fe, buried in the natural environment, at a site that had been in operation for approximately one year. This site was located at a Canadian Air Force Base in Borden, Ontario, and is described in detail by S. O'Hannesin [101]. The site had previously been used for a study of the transport of chlorinated organics in a shallow, sandy aquifer [113, 114]. These experiments left a well-defined, artificially-generated chlorinated solvent plume in a shallow sandy aquifer with a natural groundwater velocity of ~8 cm/day. This situation was deemed ideal for the demonstration of the use of Fe to remediate a plume of contaminated groundwater [51, 101, 102]. The iron zone was installed in the flow path of the contaminant plume using steel sheet pilings that were driven into the ground, interlocked and sealed [127]. This created a water-tight cell with the dimensions of 5.5 x 1.6 x 10 m (l x w x h). The cell was excavated and filled with a mixture of 22% iron filings, obtained as a waste product from a malleable iron foundry (Kanmet Castings, Cambridge, Ontario), and 72% concrete sand. The sheet pilings were then removed to create a permeable barrier that was entirely within the saturated zone of the aquifer. The buried iron zone caused dechlorination of the halogenated

compounds contained in the contaminant plume [101]. During 470 days of study, trichloroethylene concentrations within the contaminant plume decreased from 253 mg/L to 12 mg/L after passage through the Fe zone. Only dichloroethene isomers and chlorine were observed as products. A plume of dissolved iron, 1-10 mg/L, was generated by the dissolution of the Fe. Sulfate (72 kg) was added as a conservative tracer in the original transport study [113, 114] thus it was present at very high concentrations, averaging 100 mg/L during the *in situ* study.

Iron corrosion chemistry. The general definition of corrosion is degradation, or deterioration, of materials brought about through contact with their surroundings. This definition applies not only to metals, but to plastics, concrete, wood, brick, and other non-metallic materials [65, 128]. Corrosion occurs at the interface between a solid and a fluid, which can be liquid or gas or both [49]. When Fe comes in contact with aqueous solutions it begins to dissolve. The dissolution of Fe is one of several reactions combined in the term corrosion. A great deal of research has been done on the mechanisms of metal corrosion due to the deleterious effects caused by this process to man-made structures [69]. Drazic [38] provides a synthesis of currently accepted ideas about the mechanisms and kinetics of Fe corrosion. In general, the oxidation of iron metal leads to the dissolution of the ferrous species Fe^{2+} , and in some environments the formation of $\text{Fe}(\text{OH})_2$. The ferrous iron species that are produced will be rapidly converted to the ferric form in oxidizing environments:

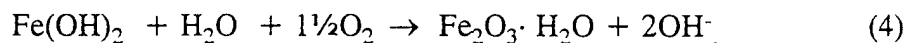
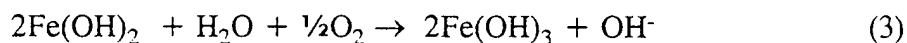
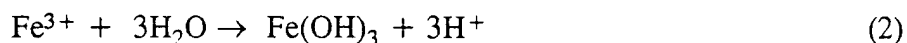

The ferric oxide and hydroxide solids formed in equations 3-4 are red-brown in color and these forms are part of the familiar coating observed on corroding Fe, called "rust." The insoluble ferric hydroxides and oxides precipitate on the surface of the corroding iron and inhibit further corrosion when the surface becomes fully coated. The

term "passivation" is used in corroding metal systems to describe this inhibition of corrosion [109].

Another product of the corrosion of iron in neutral to acid environments is the production of hydrogen gas from the reduction of water

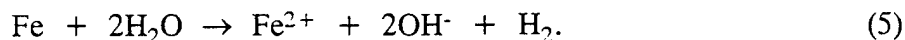

The mechanism of hydrogen formation has been studied extensively [13, 15-17, 90]. Hydrogen can also coat the surface of the iron metal and cause passivation. Figure 5.1 is a schematic illustrating the processes occurring at the iron surface during the dissolution process.

Microbial involvement in iron corrosion. The products of corrosion, ferrous and ferric iron species and hydrogen, can be used as electron donors and acceptors by a variety of microbial species. Microorganisms can also thrive in the presence of corroding iron, utilizing the hydrogen produced for the reduction of sulfate to sulfide [34]. The presence of both sulfate and Fe at the Borden site may provide a favorable environment for these types of microorganisms. Microbial activity contributes significantly to corrosion of Fe structures located in anaerobic environments such as flooded soils, marshes, bays, lakes, and oceans. The microbial corrosion of buried pipelines has been estimated to cause trillions of dollars of damage annually (Iverson, 1974). Because of the importance of microbes in the corrosion of man-made structures, microbial corrosion reactions have been the subject of study for many years [65, 66]. Biocorrosion is not a unique process, but is the net result of many different effects of microbial activity leading to conditions that cause corrosion to occur.

In 1934, von Wolzogen Kühr and van der Vlugt [143] demonstrated that corrosion of Fe in an anaerobic environment could be the result of the activity of sulfate-reducing bacteria. From this work came the controversial theory of "cathodic depolarization" in which sulfate-reducing bacteria utilize the hydrogen produced by Fe corrosion for reducing equivalents, driving the corrosion reaction shown in eq 5 to the right. More recently, this theory was dismissed by several researchers [31, 65] in favor of a mechanism emphasizing the corrosive action of compounds produced by sulfate-reducing bacteria, such as iron sulfides, hydrogen sulfide, elemental S, phosphorous compounds, and organic acids. However, the recent work of Bryant and Laishly [24]

suggests that corrosion in the presence of sulfate-reducing bacteria may be due to a combination of these factors, including the action of hydrogenases in depolarizing cathodic hydrogen from Fe corrosion or the production of corrosive metabolic end products. Regardless of which mechanism is most important, their net effect on the corrosion of iron in anaerobic environments is significant [65].

Sulfate-reducing bacteria are strict anaerobes and obtain energy by dissimilatory sulfate reduction in which sulfate is the terminal electron acceptor. Two genera of sulfate-reducers are primarily involved in Fe corrosion, *Desulfovibrio* and *Desulfotomaculum*. Electron donors for these bacteria are the fermentative end products produced by other microorganisms such as lactate, ethanol, propionate, butyrate, formate, and hydrogen.

Methanogens can also contribute to corrosion of Fe. In an experiment by Daniels and co-workers [34], a two-bottle system was used to demonstrate methanogenesis from CO₂ and the hydrogen produced by corroding Fe. The production of molecular hydrogen from Fe was demonstrated in one bottle, with concomitant methane production by methanogenic bacteria in another bottle connected through the headspace. The hydrogen was only supplied from the metal corrosion since the methanogenic culture had been originally filled with a N₂ and CO₂ atmosphere. Five different methanogens were able to produce methane from Fe and CO₂. These workers also found that *Methanobacterium thermolithotrophicus* could grow autotrophically with corroding Fe as the sole electron donor. Lorowitz and co-workers [83] observed methane production by *Methanobacterium thermoautotrophicum* in the presence of Fe and CO₂. While growth of the organism was insignificant in these systems, the presence of *M. thermoautotrophicum* was observed to increase the rate of corrosion as measured by the amount of reducing equivalents in inoculated versus control media.

Other microorganisms can contribute to the biocorrosion of Fe. Bacteria of the genus *Thiobacillus*, notably *Thiobacillus ferrooxidans*, accelerate the corrosion of Fe by production of sulfuric acid. These bacteria are acidophilic and can survive in the pH range of 1.5-4. These chemolithotrophic bacteria derive their energy from the oxidation of inorganic sulfur compounds, especially FeS, and CO₂ is reduced to provide organic intermediates for growth [89]. Thiobacilli are indirectly implicated in the anaerobic corrosion of Fe. These bacteria most likely are associated with the aerobic zone around the corroding structure, utilizing the inorganic ferrous and sulfur species that are generated during anaerobic biocorrosion. The production of sulfuric acid by these sulfur-oxidizing bacteria probably migrates to the Fe surface and causes enhanced

oxidation of the Fe. Thiobacilli also produce large amounts of slime, or biopolymer material, which may inhibit corrosion by coating the metal surface.

Iron-reducing bacteria also are not necessarily directly involved in Fe corrosion, but they may be indirectly involved. Iron-reducing bacteria use ferric iron species as electron acceptors for their metabolic activities [85]. It is possible that ferric iron will be formed as the ferrous iron, generated from the dissolution of Fe, enters an oxidizing environment. This ferric iron may be available for use by the iron-reducing microorganisms. The microbial reduction of the ferric to more soluble ferrous forms might allow the reversal of the passivation by removing the ferric oxide and hydroxide coating. The more soluble ferrous iron would be able to migrate further from the corroding iron, favoring the continued dissolution of Fe. The above is the speculation of the author, and has not been demonstrated. However, even if these microorganisms do not influence the corrosion process directly, they may be important inhabitants of the site where large amounts of Fe corrosion is occurring. The iron-oxidizing bacteria would be potentially important inhabitants in an aerobic zone that may exist prior to the iron zone, or down gradient at the aerobic "edge" of the dissolved ferrous iron plume (Figure 5.2, discussed below).

Microbial developments down gradient of the Fe zone. Figure 5.2 is a schematic illustrating the hypothetical zones of geochemical and microbiological influence that might develop during the use of buried Fe *in situ*. Although the scope of this investigation did not include sampling down gradient of the Fe zone, several hypothesis can be made concerning the microbial dynamics that might exist there. The buried Fe zone is drawn as a gray-shaded rectangle with a blue-shaded "plume" of dissolved ferrous iron traveling down gradient along the flow path. The buried iron corrodes, and in addition to dissolved Fe^{2+} , produces hydrogen. In addition to the ferrous iron and hydrogen, sulfate may be present at the site, either naturally-occurring or as a contaminant. The latter applied to the Borden demonstration site since gypsum had been added to provide a source of sulfate for a conservative tracer [113, 114]. The sulfate and the hydrogen could provide an environment favorable to sulfate-reducing bacteria present. These bacteria might exist from within the highly reducing environment to a point down gradient where the reducing conditions begin to diminish and conditions are no longer favorable for their survival. In addition to the sulfate-reducing bacteria, hydrogen- CO_2 utilizing methanogens may exist in a similar zone of

influence. The dominance of one or the other of these populations will depend on the amount of hydrogen present. Methanogens require hydrogen concentrations of 7-10 nM, which is much greater than that required by sulfate-reducing bacteria, 1-1.5 nM, and iron-reducing bacteria, 0.2 nM [86]. Sulfate-reducing bacteria are able to maintain the hydrogen concentration low enough that methanogenic hydrogen consumption is thermodynamically unfavorable [84]. Similarly, iron-reducing bacteria that are not limited in ferric iron will out-compete sulfate-reducing and methanogenic bacteria. Therefore the zones of influence for methanogens, sulfate-reducing and iron-reducing bacteria will depend on the hydrogen concentration as well as available electron acceptors for these microorganisms. This discussion illustrates that the burial of Fe in the environment can generate unique geochemical changes that may provide an interesting environment to study the ecology of the different types of hydrogen-utilizing microorganisms.

Scope of this work. From the above discussion it is apparent that many different microbiological and geochemical conditions could exist in the environment of the buried Fe zone of the described site. A high degree of microbial activity was anticipated in light of the presence of favorable conditions for many types of microorganisms, especially sulfate-reducing and iron oxidizing bacteria. In addition, large amounts of iron solids, such as ferric oxide and ferrous sulfide, were predicted. The formation of these solids in the Fe zone was anticipated to interfere with Fe dechlorination reactions. Further, microbial biomass, slime production, and production of methane and hydrogen sulfide were anticipated to have negative effects on the ability to use Fe *in situ* in the remediation of contaminated groundwater.

Core samples were obtained from the buried Fe zone at the Borden site after one, and two years of operation. These samples were analyzed by microbial and surface analysis techniques to determine the extent of microbiological and geochemical developments during the operation of the technology. The dechlorinating ability of the core Fe was determined in batch experiments similar to those described in Chapter 4.

Experimental

Core samples. Core samples were taken by S. O'Hannesin (University of Waterloo) from within the Fe zone. The first core was taken on July 10th, 1992 approximately one year after installation of the in-ground, permeable Fe barrier at Canadian Forces Base Borden, Ontario, Canada. This core was taken from a point in the barrier that was the center of both the width and length axes, and extended the total depth (Figure 5.3). The second-year core was taken on July 13th, 1993 at a diagonal through the middle of the barrier, encompassing the width from the top of the iron zone to the bottom (Figure 5.3). The coring was done by driving a 2 inch ID aluminum casing into the ground with a vibrating hammer [101]. The casings were wiped with ethanol before installation in an effort to minimize microbial contaminants. The core was sectioned into approximately 2-foot sections which were then sealed with plastic caps and tape. Approximate temperature of the groundwater at the site is 12 °C [103] and core samples were shipped in coolers with ice packs to the laboratory within four days. Cores were stored 4-15 °C upon receipt at the laboratory. Core material was extruded from the casing while at the same time the outer ¼ in of the core was removed. This was done aseptically by extruding the sections with an ethanol-sterilized device that pushed the core out with a piston advanced by a hand crank (Figure 5.4). This was done aseptically in an anaerobic chamber that is operated at conditions compatible for growth of methanogenic bacteria (approximately 70% N₂, 30% CO₂, and 0.005% O₂). The samples were extruded so that the overall profile of the core was maintained. Extruded samples were kept anaerobically in sealed jars at 4 °C.

Chemicals. Chlorinated solvents were obtained in high purity and used without further purification. These included carbon tetrachloride, HPLC grade (Aldrich); chloroform, LC grade, preserved with 1% (v/v) ethanol (Burdick & Jackson); methylene chloride, 99+%, anhydrous (Aldrich); chloromethane, 99.5+% (Aldrich); and trichloroethylene, 99+% (Aldrich). Saturated aqueous stock solutions of these

halocarbons were prepared by allowing roughly 1 mL of organic phase to equilibrate with 40 mL of water in glass vials capped with Teflon Mininert valves. Aqueous standard solutions were made by diluting the saturated stock solutions with deionized water (NANOpure, 18 M Ω -cm).

Microbiological analyses. Most Probable Number (MPN) analyses were carried out by inoculating a 3 replicate by 5 dilution scheme from a series of dilution blanks made with an initial dilution of 1 g of core sample. The first core sample was analyzed for four different types of microorganisms by using media selective for their growth. The 9K medium of Silverman and Lundgren [123] was made at pH 2-2.5 to select for acidophilic iron-oxidizing bacteria. Tubes positive for iron-oxidizing bacteria turn a distinct brown-red due to formation of ferric oxides and hydroxides. MS medium [153] with 20 mM acetate was used to select for acetoclastic methanogens. MS enrichment medium (MS medium without CoM, and reduced amounts of yeast extract and trypticase peptones) was pressurized with approximately 10 psi hydrogen gas and used to select for hydrogen-utilizing methanogens. Both of the MS media were made at pH 6.5. For both sets of MS medium, methane production was scored as a positive result for the presence of methanogens. Methane concentrations were determined by removing a 10 μ L gas sample from the headspace of the culture vessel and analyzing for methane by gas chromatography with a 2 m x 4 mm ID column packed with activated charcoal and quantification by FID. Medium B [108], pH 7.5, was used to select for sulfate-reducing bacteria. The presence of sulfate-reducing bacteria was indicated by the formation of a black precipitate, FeS. The bacterial reduction of sulfate produces sulfide, which spontaneously forms the precipitate with the ferrous iron supplied in the medium. Sodium sulfide was added to provide reducing conditions in the media and caused a slight amount of precipitate. Serum tubes with butyl-rubber stoppers were used for all of the above microbial analyses.

For the first core sample, the inoculum was made by placing 1 g of core material into 5 mL of 9K buffer at pH 7. An inoculum was made for each section of the core, for a total of five inocula. The bottles were vigorously shaken by hand approximately 30 times through a 17 inch arc. Dilutions of each inoculum were made by adding 0.5 mL of inoculum to 4.5 mL of medium appropriate for each MPN type. The MPNs were inoculated by adding 1 mL from each dilution a tube containing 9 mL

sections was inoculated into 20 mL of Medium B, at pH 7.5. Another gram of each section was placed in serum bottles containing MS enrichment medium with 25 mM acetate, at pH 6.5. A third set was made in MS enrichment medium without acetate and approximately 10 psi of hydrogen. All inoculations were done in triplicate 60-mL serum bottles with butyl-rubber stoppers, and these were incubated at 20 °C on a platform shaker. The bottles were monitored for positive results similarly to the method described above. Hydrogen-containing bottles were monitored for reduction in hydrogen.

Dehalogenating enrichments. These experiments were performed in 60-mL serum bottles with butyl-rubber or Hycar (Pierce) stoppers. Enrichments were carried out with inoculum from the MPN tubes, or samples from the core material. Medium B was used for sulfate-reducing enrichments. MS enrichment medium and MS minimal medium (no CoM, yeast extract, or trypticase peptones) were used with acetate, methanol or without substrate. Carbon tetrachloride or methylene chloride were added to these enrichments at final concentrations of approximately 100 μ M.

Abiotic dehalogenation experiments. Core material and unburied, original, Fe material (originating from Kanmet Castings, Ontario, Canada; provided by S. O'Hannesin, University of Waterloo) was used in an effort to relate laboratory batch system experiments, described in Chapter 4, to the dechlorinating activity of the site. The core material was used either undried and unseparated, or dried in an anaerobic chamber and separated with a magnet for the Fe. The unburied Fe was separated with a magnet from unidentified, non-magnetic material also present in the sample. Two methods were used to "clean" the Fe from both samples. The first used a one-hour acetone digestion, followed by three deoxygenated-deionized water rinses. The second method digested the Fe for 1 hr in 10% HCl and then rinsed as described in the first method. These samples were immediately placed in 60-mL serum bottles, completely filled with deionized-deoxygenated water, and sealed with Hycar stoppers and aluminum crimp seals. Samples were placed on a rotary shaker at 15 rpm, with an orbit radius of 15 cm, and incubated at 15 °C overnight before addition of approximately 100 μ M of chlorinated hydrocarbon. An electrolytically-produced, 100-mesh, iron powder (Certified Grade, 95%, Fisher) was used in control experiments.

Analyses. Chlorinated hydrocarbon concentrations in microbial enrichments were monitored by sampling the gas phase from cultures equilibrated at 25 °C in a water bath. The gas phase was sampled in the following manner: A 400- μ L sample chamber was fitted with a luer tip on one end, and hooked to a multiport valve (Carle) at the other end. The luer tip could attach to the culture vessel, or a disposable needle to pierce serum bottle stoppers. The valve could connect the other end of this loop to either a vacuum pump (approximately 20 psig vacuum), sample, or GC carrier gas flow (4 mL/min He). When the evacuated loop was switched open to the sample port, the chamber filled with gas from the sample headspace. The gas sample was thus kept at the pressure in the culture and no equilibrium with lab pressure, or loss of compound, occurred. These samples were analyzed by GC (HP5890A, Hewlett-Packard) with a 30-m x 0.53-mm ID glass capillary column, 5% phenyl- 95% methylsilicone phase (Supelco), in an oven heated to 150 °C. Satisfactory results were obtained with FID. Gas phase concentrations were used to determine the total concentrations using Henry's Law constants at the appropriate temperature and pH [55]. Serum bottles were inverted to minimize diffusion of halomethane into the stopper, and returned to the incubator. Chlorinated substrates and products were determined by comparison with retention times with standard compounds.

Analysis of the chlorinated solvents in the abiotic dehalogenation experiments were performed by a modification of the method for direct aqueous injection on capillary columns developed by Grob [56]. Two microliter samples, taken directly from the reaction bottles, were injected via an on-column inlet at 92 °C, to a 2.5-m x 0.53-mm ID precolumn attached to a 30-m x 0.53-mm ID DB 624 analytical column (J&W) in an oven heated to 104 °C. Satisfactory results were obtained with detection by FID. Peaks were identified by comparison with the retention times of standard compounds.

A variety of techniques were used to characterize the core material used in this study. Total carbon, nitrogen and sulfur contents of the iron metal in these samples were determined using a dedicated elemental analyzer by complete combustion with thermal conductivity detection (Carlo Erba NA-1500). The detection limit for sulfur (as SO₂) with this instrument was 10 μ g/mg dry weight of sample. Scanning electron microscopy was performed on a Zeiss 960 Digital SEM with elemental analysis by X-ray diffraction. Samples were prepared by mounting on a graphite support and coating with gold-palladium. A beryllium window was used and the average energy range of

the X-ray was 5 kV. A binocular microscope (Reichert), 0.7-4x, was also used to make general microscopic observations.

Results and Discussion

It was immediately apparent from initial inspection of the first core (July, 1992) that no dramatic microbial or geochemical changes had taken place since the installation of the Fe zone. The 1992 core consisted of a black-dark gray unconsolidated sand and Fe. The black color implies that the grains were covered with an iron oxide. However, this black coloring was present in the sample of the unburied Fe (Kanmet Castings) material that was used to construct the Fe zone and was observed as a "control." Therefore the black coloring cannot be attributed to environmental exposure alone, although some of the deposition of this material may have occurred during the field test. The 1992 core appeared surprisingly uniform over its entire length, with no apparent rust-colored ferric oxides. The second-year core (July, 1993) was very similar to the core taken one year after burial of the Fe zone, and was also surprisingly uniform in appearance over their entire length. Since the core samples encompassed the width and depth of the zone (Figure 5.3), this result means that no variations occurred spatially in the buried iron zone. Ferric oxides were postulated to form on the upgradient side of the iron zone since any ferrous iron, produced during Fe corrosion, would form a diffusion gradient opposite the groundwater flow and away from the Fe zone. This ferrous iron might be exposed to oxygen present up gradient from the Fe zone and would be oxidized to ferric oxy(hydroxides). However, this development was not apparent at either the upgradient edge, or at any other point in the iron zone, in the core samples.

The initial appearance of the iron material, before burial, was black-silver. CNS analysis showed that a significant amount of sulfur was present in the unburied Fe filings (Table 5.1). This material was obtained as a waste product from a steel casting operation in Ontario, Canada (Kanmet Castings). A magnet was used to separate the Fe from a remarkably large amount of non-magnetic black grains and clear, crystalline grains (apparently quartz). In a similar manner, the iron was separated from the 1992 core material that had been dried in an anaerobic chamber. Table 5.1 shows that this iron did not contain measurable sulfur. This result suggests that the sulfur was

contained in a coating on the original Fe material and the apparent decrease in sulfur content might be weathering of the material that occurred during exposure to groundwater flow. Additional evidence for a surface coating on the original Fe material was observed during various pretreatment processes. During acetone and hydrochloric acid exposure of the pre-burial Fe filings, a strong odor was emitted from the sample that suggested sulfide. The cleaning step was required for dechlorination to occur in the presence of the unburied Fe grains. Figure 5.5 shows that the dechlorination of carbon tetrachloride by these core samples was similar to dechlorination by reagent Fe. Similar results were obtained with post-burial Fe from the 1992 core (data not shown).

Ferric oxides and hydroxides were not obvious on the core samples visually, or with the aid of a binocular microscope (4x magnification). However, a massive formation of rust was observed after a few minutes of exposure to the laboratory atmosphere. This indicated that reducing conditions existed in the barrier, and that corroding iron was not being oxidized to Fe^{3+} .

Surface analysis was difficult with the core material because the complexity of the samples did not allow simple differentiation between iron grains and other materials. Both the iron and the sand grains were non-uniform sizes and shapes, making them difficult to distinguish after the gold-palladium coating was applied for SEM analysis. Attempts were made to separate the metal from the sand with limited success. SEM analysis with some of the more successfully separated samples did not reveal any distinguishing characteristics of corrosion, such as pitting. Elemental analysis by X-ray diffraction did not reveal any unusual surface structures or compounds other than iron species. Measurement of the top atomic layer of the sample surface is possible with this technique only through careful adjustment of the electron strength and incident angle of the beam [22]. It is likely that our measurements encompassed several layers of the iron and were essentially bulk measurements, therefore it is not surprising that iron should be the major element observed.

The schematic of hypothesized microbial developments shown in Figure 5.2 indicates that the activity of sulfate-reducing or methanogenic bacteria might increase in the Fe zone. Based on what occurs during biocorrosion of buried steel structures by these bacteria, microbial colony formation and/or bacterial slimes were predicted. However, the core samples did not exhibit obvious signs microbial colonization such as colony formation, slimes or biopolymers. These observations, visually and microscopically, did not change in the cores from the second year.

Since we had expected high activity of microorganisms known to cause biocorrosion, MPNs were performed to determine the dominant types of these organisms. However, none of the MPN analyses exhibited microbial activity, except for a low level of sulfate-reduction. The lowest of the dilutions (1×10^{-2}) used to inoculate the sulfate-reducing MPNs turned black, which indicates bacterial reduction of the sulfate to sulfide. The sulfide reacts with the ferrous iron present and precipitates as FeS. Subsequent experiments to repeat the sulfate-reducer MPN analyses were negative. Enrichment cultures were set up in an attempt to increase the populations of sulfate-reducing bacteria that were present. These enrichments were inoculated with core material and a few cultures were obtained that exhibited sulfate-reducing activity. Some of the sulfate-reduction observed in the enrichment cultures may have been due to heterotrophic activity since a putrid odor was produced in these cultures instead of the expected hydrogen sulfide odor. Because the recommended reductant, sodium sulfide [108], caused some false positive results due to the precipitation of FeS, Fe was investigated as an alternate reductant. Corroding Fe was used to supply the reducing equivalents in a set of experiments in which Fe powder was used as the reductant with Medium B in 100-mL serum bottles sealed with butyl rubber stoppers. Fe powder, when it is vigorously corroding, can create an environment suitably reducing for sulfate-reducing bacteria [108, 83]. The experiment was inoculated with an apparent sulfate-reducing culture from the enrichments. This experiment was also an attempt to determine if the organisms had evolved in the site to use the reducing equivalents provided by corroding iron, which was hypothesized in Figure 5.2. However, none of these enrichments were able to reduce sulfate.

When the 1993 cores were analyzed for microbial activity the experimental approach was modified to account for the apparent low microbial numbers of the site. The enrichments made with the 1993 core used more concentrated inocula than the MPNs for the 1992 core. Results for the 1993 core samples, from various locations in the Fe zone, are shown in Table 5.2. Similar to the cores from 1992, the sulfate-reducing activity is quite low. However, the 1993 core samples showed a slightly greater activity for acetoclastic methanogens than was seen in the 1992 core samples.

The presence of the buried Fe apparently did not result in significantly enhanced microbial populations over the generally low activities typical of the Borden site. One factor that may account for the normally low microbial activity is the low concentration of dissolved organic matter in the site groundwater. Rivett and co-workers [113, 114]

reported that the organic carbon content of the aquifer material is very low, an average concentration of 0.035% was determined from 30 samples taken from the site.

The relatively high concentrations of inorganic species at this site is another factor that may have inhibited microbial growth. The background sulfate was high because a large amount of sulfate had been added to the site in the form of gypsum [113, 114]. The gypsum was added to a buried source also containing sand saturated with various chlorinated hydrocarbons. The amounts of sulfate observed in the barrier experiments were from 10-600 mg/L [101]. Widdel and Hansen [148] found that a sulfate concentration of 260 $\mu\text{g/L}$ (25 mM) caused sulfate-reducing microorganisms to regulate sulfate uptake to avoid waste energy production and sulfate overload. These workers also reported that cells grown in the presence of excess sulfate had a lower capacity to accumulate sulfate than cells grown with much lower sulfate concentrations. Microbial inhibition by the high concentrations of dissolved iron, 1-10 mg/L, at the Borden site is not likely since several researchers have observed undiminished microbial activity in the presence of similar levels in experiments with corroding iron [34, 83].

A final factor that might be responsible for the low microbial numbers at the site is the presence of relatively high concentrations of chlorinated solvents. These compounds were added to the site by burial of chlorinated-solvent saturated soil that had continued to produce a plume of tetrachloroethylene, trichloroethylene, and chloroform contaminated groundwater for nearly two years before the iron zone was constructed. The plume concentrations were still high, 100-300 mg/L, three years after source emplacement. This translates to a maximum concentration of 840 μM for chloroform, which is a high enough halomethane concentration to cause inhibition of some microorganisms. For example, methanogenesis was completely inhibited in sewage sludge enrichments exposed to 200 μM carbon tetrachloride [135], and in pure cultures of *Methanosarcina* exposed 100 μM methylene chloride shown in the studies in Chapter 2.

Microbial effects on dechlorination in the Fe zone. On the premise that the presence of microorganisms might affect the process of dehalogenation by Fe buried in the subsurface, one series of experiments were conducted in the closed anaerobic batch systems containing deionized water and acid-pretreated Fe. The sulfate-reducing enrichments, described above, were used to inoculate autoclaved batch systems 1 hour

prior to addition of approximately 100 μM carbon tetrachloride. Figure 5.6 shows that the average dechlorination rate of the inoculated bottles was much slower ($k_{\text{obs}}=0.0087 \pm 0.0005$; $n=14$; $r^2=0.958$) than the autoclaved controls ($k_{\text{obs}}=0.022 \pm 0.001$; $n=9$; $r^2=0.985$) and the unautoclaved controls ($k_{\text{obs}}=0.044 \pm 0.001$; $n=8$; $r^2=0.996$). The significant decrease in the dechlorination rate of the inoculated batch systems indicates that the presence of bacterial cells inhibits the dechlorination of carbon tetrachloride by iron. The rate of dechlorination in the autoclaved, inoculated samples is 60% less than the rate of dechlorination in the autoclaved, uninoculated controls. This effect was not investigated further, but is reminiscent of the partial oxidation of sediment slurries caused by the autoclaving process [137]. Incubation temperature did not have an effect on the dechlorination rate of any of the treatments.

The inhibition of dechlorination by Fe in the presence of microorganisms may be due to several factors, such as the attachment of the cells to the iron surface or the utilization of reducing equivalents (such as hydrogen) by the bacteria. The formation of biofilms on the surface of the iron would reduce the available surface area for dechlorination of the substrate. The importance of the surface area in the dechlorination reaction is shown in Figure 4.5 in Chapter 4. The possibility of microbial utilization of the hydrogen produced during corrosion is supported by phase-contrast light microscopic observations indicating that cell numbers increased during the experiment. The bacteria may have been able to metabolize carbon dioxide and the hydrogen generated by the corroding Fe. The bacteria may have scavenged the hydrogen as it was produced at the surface of the iron, which would interfere with the halomethane reduction at that active site. This may account for the decreased rates of dehalogenation in the inoculated samples.

Conclusions

The vigorous growth of microorganisms will have an effect on the ability to use the buried Fe as a remediation technique. Microorganisms not only could affect dechlorination of halogenated compounds at the Fe surface (Figure 4.2), but could also affect the physical properties of the subsurface such as porosity and permeability [25, 125] by precipitation of iron oxides, formation of bacterial slimes and/or large colony formations. Another effect of the microbial activity is the production of hydrogen sulfide from sulfate by sulfate reducing bacteria. Hydrogen sulfide gas has an unpleasant odor and could be a nuisance to nearby inhabitants of the site.

Finally, microbes capable of dehalogenating chlorinated contaminants might be able to thrive in the conditions provided by corroding Fe. For example, chlorinated aliphatics and aromatics are transformed by pure cultures of sulfate-reducing bacteria and sulfate-reducing consortia [8, 35, 77, 97]. Dehalogenating microorganisms would have a selective advantage over other bacteria for survival in the chlorinated organic contaminant site.

The work presented here is based on samples from one field site, so it is difficult to anticipate how much variation in geomicrobiology can be expected from site to site. The low microbial activity of the Borden demonstration may be due to a number of factors unique to the site. However, it appears that microorganisms do not interfere significantly with the use of buried Fe to reductively dehalogenate contaminants.

Table 5.1 CNS Analysis of Bulk Composition of Iron Barrier Material.

Sample		Carbon (%)	Nitrogen (%)	Sulfur (%)
Core 1 ^a	repl. 1	1.77	0.19	0.00
	repl. 2	2.67	0.39	0.00
	repl. 3	3.04	0.27	0.00
	$\bar{x} \pm 1$ sd	2.50 \pm 0.65	0.29 \pm 0.10	0.00 \pm 0.00
Iron Filings ^b	repl. 1	1.94	0.31	0.37
	repl. 2	1.80	0.19	0.36
	repl. 3	1.94	0.27	0.41
	$\bar{x} \pm 1$ sd	1.90 \pm 0.08	0.26 \pm 0.06	0.38 \pm 0.03
Reagent Fe ^c	repl. 1	0.40	1.18	0.00
	repl. 2	0.24	1.30	0.00
	repl. 3	0.27	1.36	0.00
	$\bar{x} \pm 1$ sd	0.30 \pm 0.09	1.28 \pm 0.08	0.00 \pm 0.00

^a Material from first-year cores.

^b The iron filings were used in construction of the in-ground, permeable barrier and originated from Kanmet Castings, Ontario. Provided by S. O'Hannesin, University of Waterloo.

^c Fisher iron powder (Certified Grade), 100 mesh, was used as a reference.

Table 5.2 Enrichment Results for the July 13, 1993 Cores.^a

Sample		Outside Fe Zone	Top Fe Zone	Mid- Fe Zone	Bottom Fe Zone
SRB ^b	repl. 1	+	+/-	+/-	+/-
	repl. 2	ND	+/-	-	-
	repl. 3	ND	+/-	+	-
MSE ^c	repl. 1	-	+	-	-
	repl. 2	-	+/-	+	-
	repl. 3	-	-	+/-	-
MS-H ₂ ^d	repl. 1	-	+	+	+
	repl. 2	+	+	+	+

ND = not done

^a 1g (wet wt.) core material added to 20 mL media. Scoring: + denotes a positive result, +/- indicates weak positive result, - is a negative result. Positive and negative criteria are defined in the text.

^b Sulfate-reducing enrichment: Medium B, pH 7.5, 25 °C.

^c Acetoclastic methanogenic enrichment: MS enrichment medium, pH 6.5, 25 mM acetate, 25 °C.

^d Hydrogen-utilizing methanogenic enrichment: MS enrichment medium, pH 6.5, ca. 10 psi hydrogen, 20 °C.

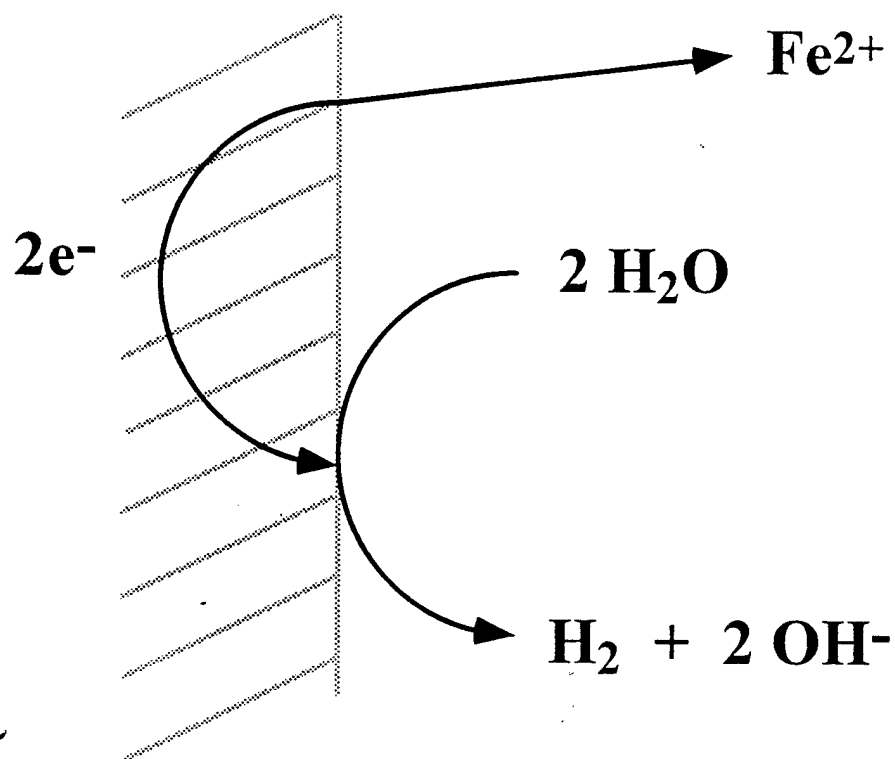

Figure 5.1 Schematic showing general corrosion processes at the Fe surface.

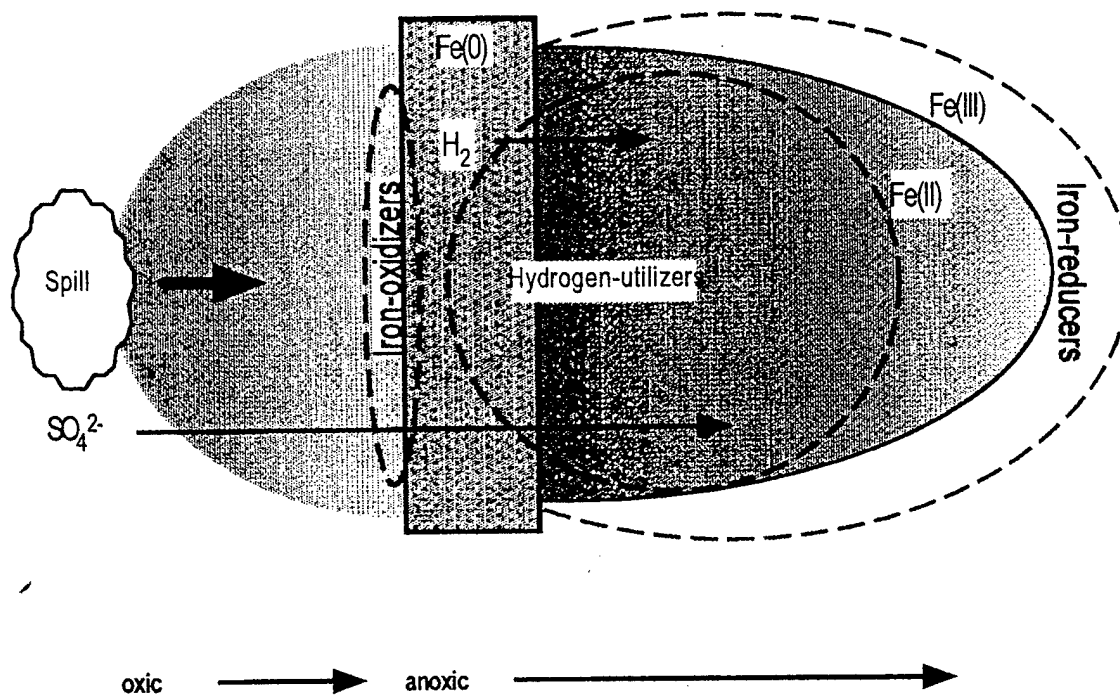

Figure 5.2 Schematic showing hypothetical domains of influence for microbial activity in a site containing a zone of buried Fe.

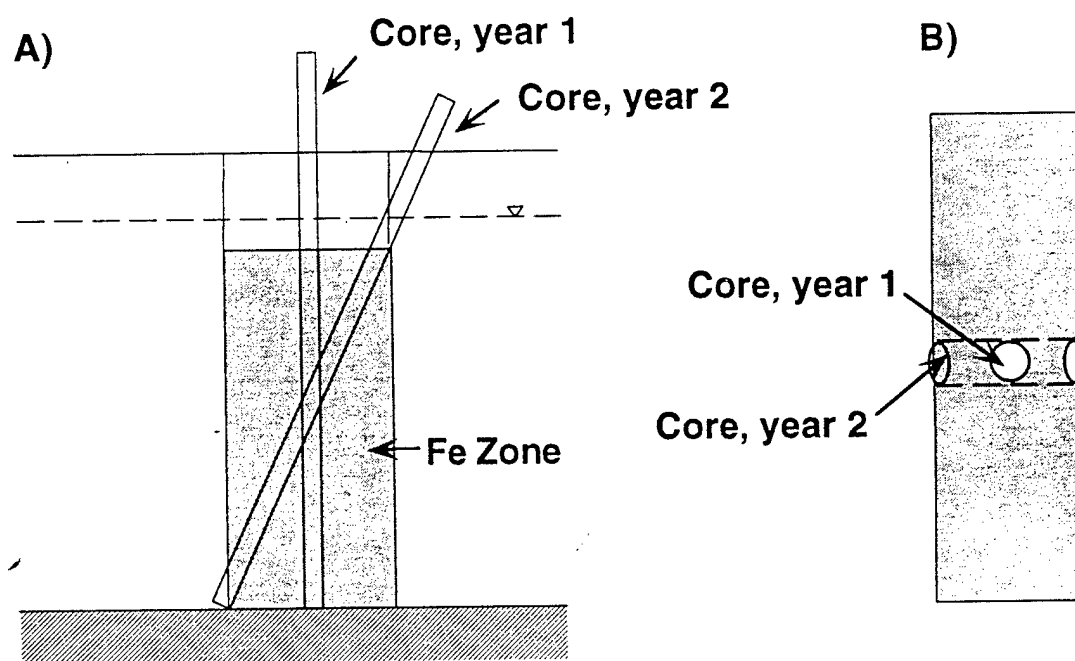

Figure 5.3 Schematic of the buried Fe barrier showing the location of the core samples. A) Side View; B) Plan view.

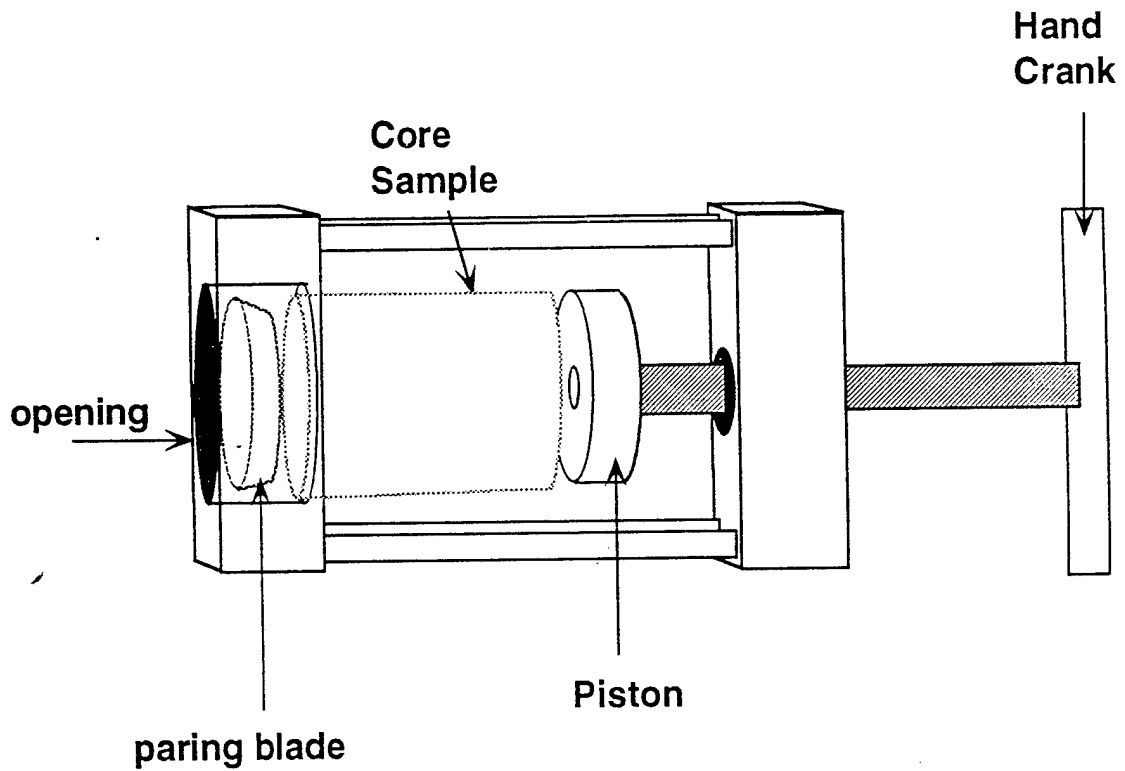

Figure 5.4 Illustration of the core sample extruder. Core is held in place while a piston is advanced through the core tube, paring $\frac{1}{4}$ in from the outer surface of the core, and extruding the contents in a continuous sample. Extruder designed by C. Palmer (Oregon Graduate Institute of Science and Technology).

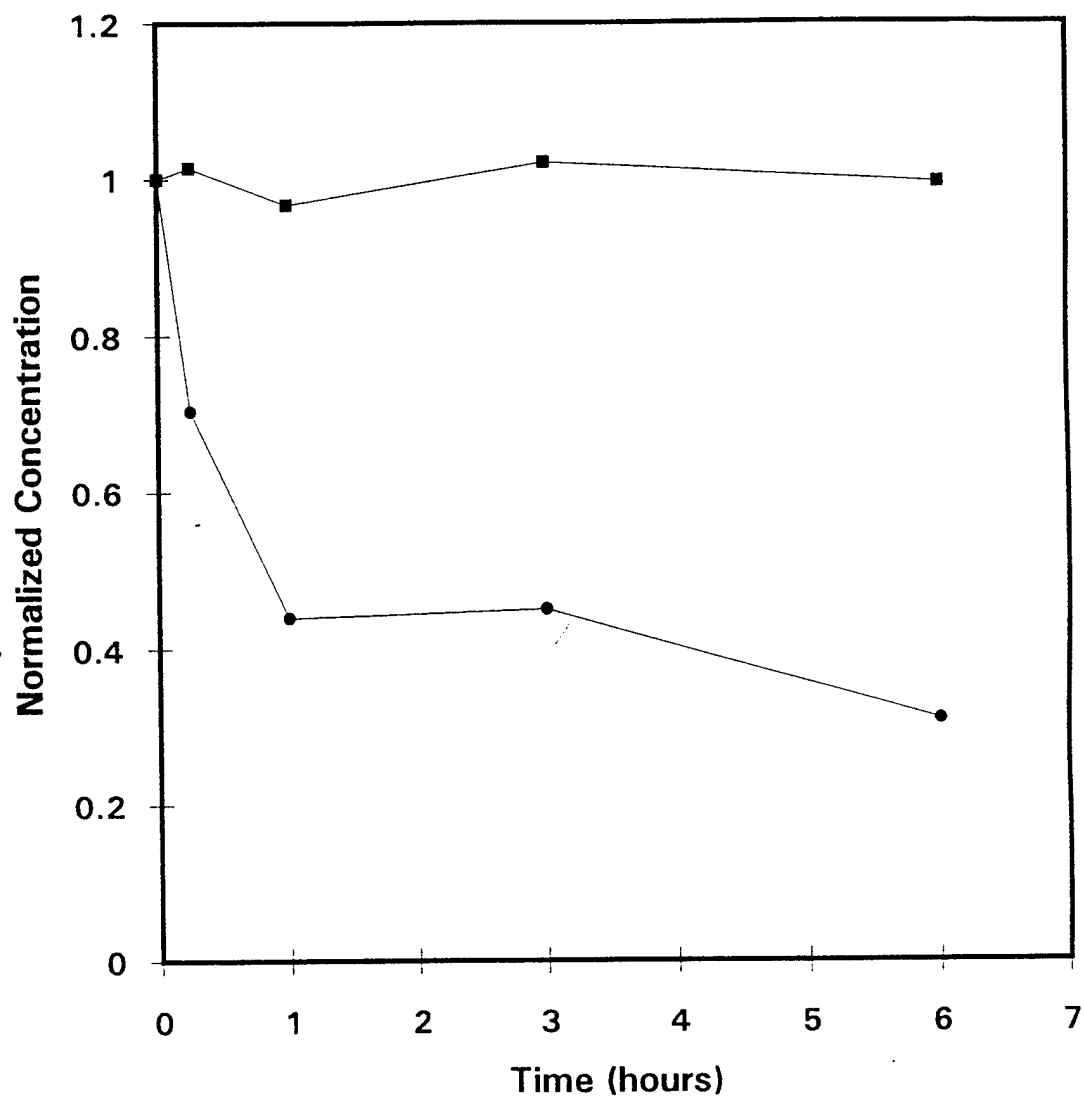

Figure 5.5 Dechlorination of carbon tetrachloride with acetone- and HCl- cleaned unburied Fe (Kanmet Castings, Ontario, Canada). HCl-treated (squares) and acetone-treated (circles) Fe was exposed for 1 hr in each treatment and rinsed before use in the anaerobic batch experiment. Carbon tetrachloride initial concentrations were approximately 100 μM . Incubation at 15 rpm 15 °C.

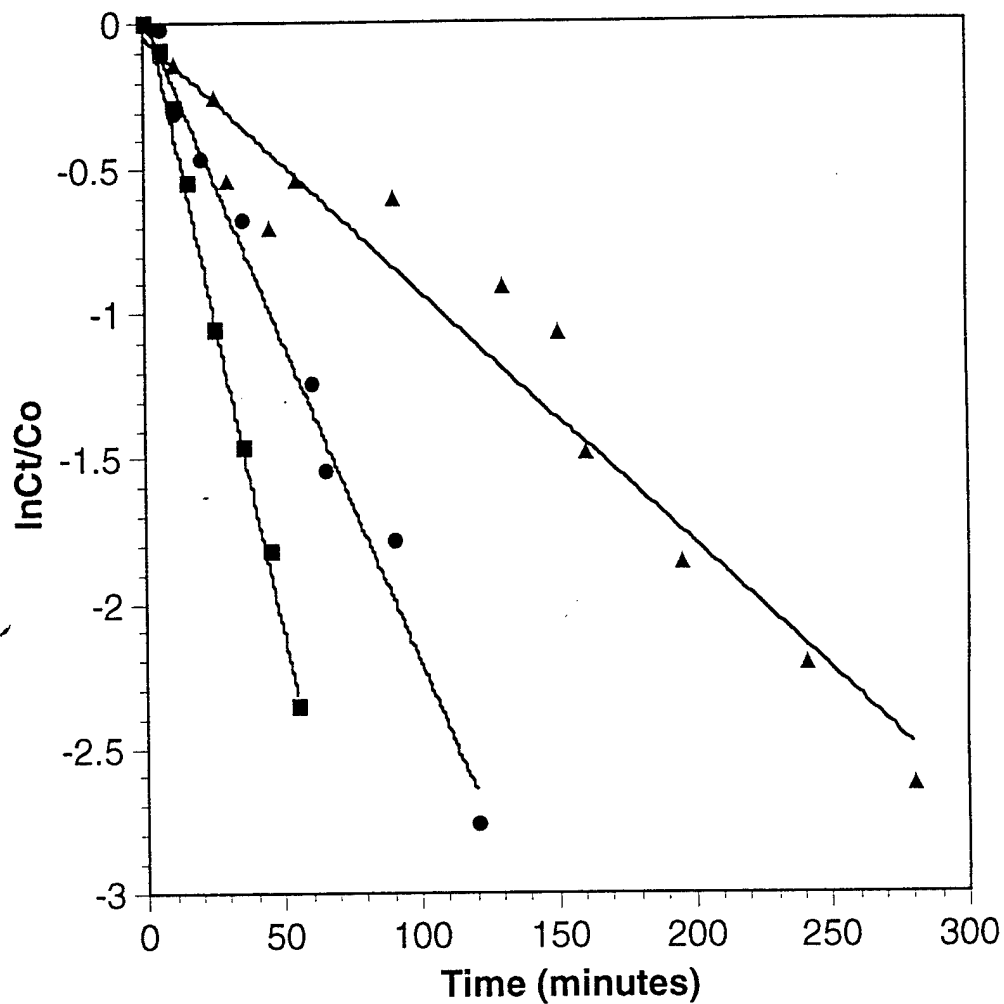

Figure 5.6 Effect of a bacterial inoculum on dechlorination of carbon tetrachloride by laboratory batch systems. Triangles = autoclaved, inoculated samples; squares = unautoclaved, uninoculated controls; circles = autoclaved, uninoculated controls. Approximately 2×10^7 cells/mL were added to the bottles one hour prior to addition of $100 \mu\text{M}$ carbon tetrachloride. Bottles were incubated at 25°C and at 15°C on rotary shakers at 15 rpm. The general experimental procedure is described in Chapter 4.

References

1. *Halocarbons: Effects on Stratospheric Ozone*, Panel on Atmospheric Chemistry, National Research Council. 1976, National Academy of Sciences: Washington, DC.
2. *Chloroform, Carbon Tetrachloride, and Other Halomethanes: An Environmental Assessment*. In *Scientific and Technical Assessments of Environmental Pollutants*, Ed. National Research Council. 1978, National Academy of Sciences: Washington, DC.
3. *Toxicological Profile for Carbon Tetrachloride*. Ed. Agency for Toxic Substances and Disease Registry, U.S. Public Health Service. 1989, U.S. Environmental Protection Agency: Washington, DC.
4. Archer, W.L. 1982. Aluminum-1,1,1-trichloroethane. Reactions and Inhibition. *Ind. Eng. Chem. Prod. Res. Dev.* **21**:670-672.
5. Archer, W.L. and M.K. Harter. 1978. Reactivity of carbon tetrachloride with a series of metals. *Corrosion.* **34**:159-162.
6. Archer, W.L. and E.L. Simpson. 1977. Chemical profile of polychloroethanes and polychloroalkenes. *Ind. Eng. Chem. Prod. Res. Dev.* **16**:158-162.
7. Assaf-Anid, N., K.F. Hayes, and T.F. Vogel. 1993. Reductive dechlorination of carbon tetrachloride by cobalamin(II) in the presence of dithiothreitol: mechanistic study, effect of redox potential and pH. *Environ. Sci. Technol.* **28**:246-252.
8. Bagley, D.M. and J.M. Gossett. 1990. Tetrachloroethene transformation to trichloroethene and *cis*-1,2-dichloroethene by sulfate-reducing enrichment cultures. *Appl. Environ. Microbiol.* **56**:2511-2516.

9. Baxter, R.M. 1990. Reductive dechlorination of certain chlorinated organic compounds by reduced hematin compared with their behaviour in the environment. *Chemosphere*. **21**:451-458.
10. Bellar, T.A., J.J. Lichtenberg, and R.C. Kroner. 1974. The occurrence of organohalides in chlorinated drinking waters. *J. Am. Water Works Assoc.* **66**:703-706.
11. Berry, J.D. and D.A. Stotter. 1977. Dechlorination of DDT by vitamin B₁₂ under mildly reducing conditions. *Chemosphere*. **11**:783-787.
12. Berry, L.G. and B. Mason, *Mineralogy: Concepts, Descriptions, Determinations*. 1959, W.H. Freeman and Company: San Francisco.
13. Bockris, J.O., J.L. Carbajal, B.R. Scharifker, and K. Chandrasekaran. 1987. Adsorbed hydrogen on iron in the electrochemical reduction of protons. An FTIR study. *J. Electrochem. Soc.* **134**:1957-1963.
14. Bockris, J.O. and S.U.M. Khan, *Surface Electrochemistry. A Molecular Level Approach*. 1993, Plenum: New York.
15. Bockris, J.O. and D.F.A. Koch. 1961. Comparative rates of the electrolytic evolution of hydrogen and deuterium of iron, tungsten and platinum. *J. Phys. Chem.* **65**:1941-1948.
16. Bockris, J.O. and A.K.N. Reddy, *Modern Electrochemistry*. Vol. 2. 1970, Plenum: New York.
17. Bockris, J.O. and A.K.N. Reddy, *Modern Electrochemistry*. Vol. 1. 1970, Plenum: New York.
18. Boone, D., R., *Ecology of Methanogenesis*. In *Microbial Production and Consumption of Greenhouse Gases: Methane, Nitrogen Oxides, and Halomethanes.*, J.E. Rogers and W.B. Whitman, Eds. 1991, American Society for Microbiology: Washington, D.C. pp. 57-70.

19. Boyd, S.A., J.-F. Lee, and M.M. Mortland. 1988. Attenuating organic contaminant mobility by soil modification. *Nature*. **333**:345-347.
20. Bratsch, S.G. 1989. Standard electrode potentials and temperature coefficients in water at 298.15 K. *J. Phys. Chem. Ref. Data*. **18**:1-21.
21. Brewster, J.H. 1954. Mechanisms of reductions at metal surfaces. I. A general working hypothesis. *J. Am. Chem. Soc.* **76**:6361-6363.
22. Brown, G.E.J., *Spectroscopic studies of chemisorption reaction mechanisms at oxide-water interfaces*. In *Mineral-Water Interface Chemistry*, M.F.J. Hochella and A.F. White, Eds. 1990, Mineralogical Society of America: Washington, DC. pp. 309-363.
23. Brown, R.H., E.H. Cook, M.H. Brown, and J.D. Minford. 1959. Reaction of aluminum and carbon tetrachloride, II. *J. Electrochem. Soc.* **106**:192-199.
24. Bryant, R.D. and E.J. Laishley. 1990. The role of hydrogenase in anaerobic corrosion. *Can. J. Microbiol.* **36**:259-264.
25. Bubela, B. 1985. Effect of biological activity on the movement of fluids through porous rocks and sediments and its application to enhanced oil recovery. *Geomicrobiol. J.* **4**:313-327.
26. Cannon, R.D., *Electron Transfer Reactions*. 1980, Butterworth: London.
27. Capellos, C. and B.H.J. Bielski, *Kinetic Systems: Mathematical Descriptions of Chemical Kinetics in Solution*. 1972, Wiley: New York.
28. Casanova, J. and L. Ebersson, *Electrochemistry of the carbon-halogen bond*, in *The Chemistry of the Carbon-Halogen Bond, Part 2*, S. Patai, Editor. 1973, Wiley: London. pp. 979-1047.

29. Castro, C.E., R.S. Wade, and N.O. Belser. 1985. Biodehalogenation: Reactions of cytochrome P-450 with polyhalomethanes. *Biochem.* **24**:204-210.
30. Cotruvo, J.A. and C. Wu. 1978. Controlling Organics: Why Now? *J. Am. Water Works Assoc.* **70**:590-594.
31. Cragnolino, G. and O.H. Tuovinen. 1984. The role of sulphate-reducing and sulphur-oxidizing bacteria in the localized corrosion of iron-based alloys: a review. *Int. Biodet.* **20**:9-25.
32. Criddle, C.S. and P.L. McCarty. 1991. Electrolytic model system for reductive dehalogenation in aqueous environments. *Environ. Sci. Technol.* **25**:973-978.
33. Cumberland, J.H., J.R. Hibbs, and I. Hoch, Eds. *The Economics of Managing Chlorofluorocarbons: Stratospheric Ozone and Climate Issues*. 1982, Resources For The Future: Washington, DC.
34. Daniels, L., N. Belay, B.S. Rajagopal, and P.J. Weimer. 1987. Bacterial methanogenesis and growth from CO₂ with elemental iron as the sole source of electrons. *Science.* **237**:509-511.
35. DeWeerd, K.A., L. Mandelco, R.S. Tanner, C.R. Woese, and J.M. Suflita. 1990. *Desulfomonile tiedjei* gen. nov. and sp. nov., a novel anaerobic, dehalogenating, sulfate-reducing bacterium. *Arch. Microbiol.* **154**:23-30.
36. DiMarco, A.A., T.A. Bobik, and R.S. Wolfe. 1990. Unusual coenzymes of methanogenesis. *Annu. Rev. Biochem.* **59**:335-394.
37. Doong, R.-A. and S.-C. Wu. 1992. Reductive dechlorination of chlorinated hydrocarbons in aqueous solutions containing ferrous and sulfide ions. *Chemosphere.* **24**:1063-1075.
38. Drazic, D.M., *Iron and its electrochemistry in an active state*. In *Modern Aspects of Electrochemistry*, B.E. Conway, J.O. Bockris, and R.E. White, Eds. 1989, Plenum: New York. pp. 69-192.

39. Ebersson, L. 1982. Electron transfer reactions in organic chemistry. II. An analysis of alkyl halide reduction by electron transfer reagents on the basis of the Marcus theory. *Acta Chem. Scand.* **B36**:533-543.
40. Edwards, P.R., I. Campbell, and G.S. Milne. 1982. The impact of chloromethanes on the environment: Part 1, the atmospheric chlorine cycle. *Chemistry and Industry (London)*. 21 August 1982, pp. 574-578.
41. Edwards, P.R., I. Campbell, and G.S. Milne. 1982. The impact of chloromethanes on the environment: Part 2, methyl chloride and methylene chloride. *Chemistry and Industry (London)*. 4 September 1982, pp. 619-622.
42. Egli, C., S. Stromeier, A.M. Cook, and T. Leisinger. 1990. Transformation of tetra- and trichloromethane to CO₂ by anaerobic bacteria is a non-enzymatic process. *FEMS Microbiol. Lett.* **68**:207-212.
43. Erickson, M.D. and E.D. Estes, *Evaluation of chlorinated hydrocarbon catalytic reduction technology*, in *Task Final Report*. 1978, Research Triangle Institute: Research Triangle Park, NC.
44. Esaac, E.G. and F. Matsumura. 1980. Metabolism of insecticides by reductive systems. *Pharmac. Ther.* **9**:1-26.
45. Fathepure, B.Z. and S.A. Boyd. 1988. Dependence of tetrachloroethylene dechlorination on methanogenic substrate consumption by *Methanosarcina* sp. Strain DCM. *Appl. Environ. Microbiol.* **54**:2976-2980.
46. Fishbein, L. 1976. Industrial mutagens and potential mutagens 1. Halogenated aliphatic derivatives. *Mutat. Res.* **32**:267-308.
47. Freedman, D.L. and J.M. Gossett. 1991. Biodegradation of dichloromethane and its utilization as a growth substrate under methanogenic conditions. *Appl. Environ. Microbiol.* **57**:2847-2857.

48. Gantzer, C.J. and L.P. Wackett. 1991. Reductive dechlorination catalyzed by bacterial transition-metal coenzymes. *Environ. Sci. Technol.* **25**:715-722.
49. Gardner, G.S. 1963. Velocity studies: diffusion-controlled corrosion reactions. *Corrosion.* **19**:81t-90t.
50. Gibbs, M.M. 1979. A simple method for the rapid determination of iron in natural waters. *Water Res.* **13**:295-297.
51. Gillham, R.W. and D.R. Burris. *In situ treatment walls—Chemical dehalogenation, denitrification, and bioaugmentation.* In *Subsurface Restoration Conference, Dallas TX.* 1992, US Environmental Protection Agency, Kerr Laboratory, Ada, OK.
52. Gillham, R.W. and S.F. O'Hannesin. *Metal-catalysed abiotic degradation of halogenated organic compounds.* In *IAH Conference "Modern Trends in Hydrogeology".* 1992. Hamilton, Ontario, Canada.
53. Glass, B.L. 1972. Relation between the degradation of DDT and the iron redox system in soils. *J. Agr. Food Chem.* **20**:324-327.
54. Good, N.E., G.D. Winget, W. Winter, T.N. Connolly, S. Izawa, and R.M.M. Singh. 1966. Hydrogen ion buffers for biological research. *Biochemistry.* **5**:467-477.
55. Gossett, J.M. 1987. Measurement of Henry's Law constants for C₁ and C₂ chlorinated hydrocarbons. *Environ. Sci. Technol.* **21**:202-208.
56. Grob, K. and F. Küffer. 1990. Analysis of volatile halocarbons in water by GC-ECD involving direct on-column injection of the sample. *J. High Res. Chromatogr.* **13**:561-564.
57. Grunze, M. and P.A. Dowben. 1982. A review of halocarbon and halogen adsorption with particular reference to iron surfaces. *App. Surf. Sci.* **10**:209-239.

58. Hermosin, M.C. and J. Cornejo. 1992. Removing 2,4-D from water by organo-clays. *Chemosphere*. **24**:1493-1503.
59. Hileman, B., *News Focus: Concerns broaden over chlorine and chlorinated hydrocarbons*. In *Chemical & Engineering News*, 19 April 1993, pp. 11-20.
60. Hill, H.A.O., J.M. Pratt, M.P. O'Riordan, F.R. Williams, and R.J.P. Williams. 1971. The chemistry of Vitamin B₁₂ Part XV. catalysis of alkyl halide reduction by Vitamin B₁₂: Studies using controlled potential reduction. *J. Am. Chem. Soc. (A)*. pp. 1859-1862.
61. House, H.O., *Modern Synthetic Reactions*. 2nd ed. 1972, W. A. Benjamin: Menlo Park, CA.
62. Hudlicky, M., *Reductions in Organic Chemistry*. 1984, Ellis Horwood: Chichester, England.
63. Hung, W.-H., J. Schwartz, and S.L. Bernasek. 1991. Sequential oxidation of Fe(100) by water adsorption: formation of an ordered hydroxylated surface. *Surf. Sci.* **248**:332-342.
64. Hush, N.S.Z. 1957. Electrode reactions of methyl halides. *Z. Elektrochem.* **61**:734-738.
65. Iverson, W.P., *Microbial corrosion of iron*. In *Microbial Iron Metabolism*, J.B. Neilands, Editor. 1974, Academic Press: N.Y. pp. 475-513.
66. Iverson, W.P. 1987. Microbial corrosion of metals. *Adv. Appl. Microbiol.* **32**: p. 1-20.
67. Jaynes, W.F. and S.A. Boyd. 1991. Clay mineral type and organic compound sorption by hexadecyltrimethylammonium-exchanged clays. *Soil Sci. Soc. Am. J.* **55**:43-48.

68. Jeffers, P.M., L.M. Ward, L.M. Woytowitch, and N.L. Wolfe. 1989. Homogeneous hydrolysis rate constants for selected chlorinated methanes, ethanes, ethenes, and propanes. *Environ. Sci. Technol.* **23**:965-969.
69. Jones, D.A., *Principles and Prevention of Corrosion*. 1992, Macmillan: New York.
70. Klecka, G.M. and S.J. Gonsior. 1984. Reductive dechlorination of chlorinated methanes and ethanes by reduced iron (II) porphyrins. *Chemosphere*. **13**:391-402.
71. Kobayashi, H. and B.E. Rittmann. 1982. Microbial removal of hazardous organic compounds. *Environ. Sci. Technol.* **16**:170A-183A.
72. Kriegman-King, M.R. and M. Reinhard. 1992. Transformation of carbon tetrachloride in the presence of sulfide, biotite, and vermiculite. *Environ. Sci. Technol.* **26**:2198-2206.
73. Krone, U.E., K. Laufer, R.K. Thauer, and H.P.C. Hogenkamp. 1989. Coenzyme F₄₃₀ as a possible catalyst for the reductive dehalogenation of chlorinated C1 hydrocarbons in methanogenic bacteria. *Biochemistry*. **28**:10061-10065.
74. Krone, U.E. and R.K. Thauer. 1992. Dehalogenation of trichlorofluoromethane (CFC-11) by *Methanosarcina barkeri*. *FEMS Microbiol. Lett.* **90**:201-204.
75. Krone, U.E., R.K. Thauer, and H.P.C. Hogenkamp. 1989. Reductive dehalogenation of chlorinated C1-hydrocarbons mediated by corrinoids. *Biochemistry*. **28**:4908-4914.
76. Krone, U.E., R.K. Thauer, H.P.C. Hogenkamp, and K. Steinbach. 1991. Reductive formation of carbon monoxide from CCl₄ and FREONs 11, 12, and 13 catalyzed by corrinoids. *Biochemistry*. **30**:2713-2719.
77. Kuhn, E.P., G.T. Townsend, and J.M. Suflita. 1990. Effect of sulfate and organic carbon supplements on reductive dehalogenation of chloroanilines in anaerobic aquifer slurries. *Appl. Environ. Microbiol.* **56**:2630-2637.

78. Larson, R.A. and E.J. Weber, *Reaction Mechanisms in Environmental Organic Chemistry*. 1993, Lewis: Chelsea, MI.
79. Laszlo, P. 1987. Chemical reactions on clays. *Science*. **235**:1473-1477.
80. Leisinger, T. 1983. Microorganisms and xenobiotic compounds. *Experientia*. **39**:1183-1191.
81. Lesage, S., S. Brown, and K.R. Hosler. 1992. Degradation of chlorofluorocarbon-113 under anaerobic conditions. *Chemosphere*. **24**:1225-1243.
82. Light, T.S. 1972. Standard solution for redox potential measurements. *Anal. Chem.* **44**:1038-1039.
83. Lorowitz, W.H., D.P.J. Nagle, and R.S. Tanner. 1992. Anaerobic oxidation of elemental metals coupled to methanogenesis by *Methanobacterium thermoautotrophicum*. *Environ. Sci. Technol.* **26**:1606-1610.
84. Lovley, D.R., *Metabolism of fermentation intermediates in lake sediments*. 1982, Michigan State University: Ph.D. Thesis.
85. Lovley, D.R. 1991. Dissimilatory Fe(III) and Mn(IV) reduction. *Microbiol. Rev.* **55**:259-287.
86. Lovley, D.R. and S. Goodwin. 1988. Hydrogen concentrations as an indicator of the predominant terminal electron-accepting reactions in aquatic sediments. *Geochim. et Cosmochim. Acta.* **52**:2993-3003.
87. Luke, B.T., G.H. Loew, and A.D. McLean. 1987. Theoretical investigations of the anaerobic reduction of halogenated alkanes by cytochrome P-450. 1. Structures, inversion barriers, and heats of formation of halomethyl radicals. *J. Am. Chem. Soc.* **109**:1307-1317.

88. Luke, B.T., G.H. Loew, and A.D. McLean. 1988. Theoretical investigation of the anaerobic reduction of halogenated alkanes by cytochrome P-450. 2. vertical electron affinities of chlorofluoromethanes as a measure of their affinity. *J. Am. Chem. Soc.* **110**:3396-3400.
89. Lundgren, D.G., J.R. Vestal, and F.R. Tabita, *The iron-oxidizing bacteria*. In *Microbial Iron Metabolism*, J.B. Neilands, Editor. 1974, Academic Press: N.Y. pp. 457-473.
90. MacDonald, D.D., *The electrolyte-iron interface*. In *Hydrogen Degradation of Ferrous Alloys*, R.A. Oriani, J.P. Hirth, and M. Smialowski, Eds. 1985, Noyes: Park Ridge, NJ. pp. 78-113.
91. Macek, T.J. and B.A. Feller. 1952. Crystalline vitamin B₁₂ in pharmaceutical preparations. *J. Am. Pharm. Assoc.* **41**:285-288.
92. Marks, T.S., J.D. Allpress, and A. Maule. 1989. Dehalogenation of lindane by a variety of porphyrins and corrins. *Environ. Sci. Technol.* **55**:1258-1261.
93. Marks, T.S. and A. Maule, *Use of metal chelate complexes in dehalogenation*. 1989, International Patent Application No. PCT/GB89/00478: World Intellectual Property Organization.
94. Marks, T.S. and A. Maule. 1992. The use of immobilized porphyrins and corrins to dehalogenate organochlorine pollutants. *Appl. Microbiol. Biotechnol.* **38**:413-416.
95. Miaw, C.-L., N. Hu, J.M. Bobbitt, Z. Ma, M.F. Ahmadi, and J.F. Rusling. 1993. Electrochemistry and catalysis with vitamin B₁₂ hexacarboxylate in an insoluble surfactant film. *Langmuir.* **9**:315-322.
96. Mikesell, M.D. and S.A. Boyd. 1990. Dechlorination of chloroform by *Methanosarcina* strains. *App. Environ. Microbiol.* **56**:1198-1201.

97. Mohn, W.W. and J.M. Tiedje. 1992. Microbial reductive dehalogenation. *Microbiol. Rev.* **56**:482-507.
98. Moriguchi, I. and N. Kaneniwa. 1969. Adsorption of solute from the solutions. II. Competitive adsorption of cyanocobalamin with pyridoxine and thiamine on talc. *Chem. Pharm. Bull.* **17**:394-397.
99. Moriguchi, I. and N. Kaneniwa. 1969. Adsorption of solute from the solutions. III. Repression of adsorption of cyanocobalamin on talc by polyvinylpyrrolidone. *Chem. Pharm. Bull.* **17**:961-965.
100. Murakami, Y., Y. Hisaeda, T. Ozaka, and Y. Matsuda. 1989. Electrochemical carbon-skeleton rearrangements catalysed by hydrophobic vitamin B₁₂ immobilised in a polymer-coated electrode. *J. Chem. Soc. Chem. Commun.* **16**:1094-1096.
101. O'Hannesin, *A Field Demonstration of a Permeable Reaction Wall for the In Situ Abiotic Degradation of Halogenated Aliphatic Compounds*. 1993, University of Waterloo, Ontario, Canada: M.S. Thesis.
102. O'Hannesin, S. and R.W. Gillham. 1993. In Situ degradation of halogenated organics by permeable reaction wall. *EPA Groundwater Currents*. Issue: EPA/542/N-93/003.
103. O'Hannesin, S.F. and R.W. Gillham. *A permeable reaction wall for in situ degradation of halogenated organic compounds*. In *Proceedings of the 45th Canadian Geotechnical Society Conference*. 1992. Toronto, Ontario.
104. Orth, W.S., *Mass Balance of the Degradation of Trichloroethylene in the Presence of Iron Filings*. 1993, University of Waterloo, Ontario: M.S. Thesis.
105. Pankow, J.F., S. Feenstra, J.A. Cherry, and M.C. Ryan, *Chapter 1. Dense Chlorinated Solvents in Groundwater. A History of the Problem*. In *Dense Chlorinated Solvents in Groundwater Systems: Principles Affecting Fate, Transport, and Remediation*, in press.

106. Pankow, J.F. and M.E. Rosen. 1988. Determination of volatile compounds in water by purging directly to a capillary column with whole column cryotrapping. *Environ. Sci. Technol.* **22**:398-405.
107. Peel, J.L. 1972. The use of electron acceptors, donors and carriers. *Methods in Microbiology.* **6B**:1.
108. Postgate, J.R., *Genus Desulfovibrio*. In *Bergey's Manual of Systematic Bacteriology, Vol. 1*. 1981, Williams & Wilkins: Baltimore. pp. 666-672.
109. Pourbaix, M., *Atlas of Electrochemical Equilibria in Aqueous Solutions*. 1966, Pergamon Press: Oxford.
110. Rasmussen, R.A., L.E. Rasmussen, M.A.K. Khalil, and R.W. Dalluge. 1980. Concentration distribution of methyl chloride in the atmosphere. *J. Geophys. Res.* **85**:7350-7356.
111. Reynolds, G.W., J.T. Hoff, and R.W. Gillham. 1990. Sampling bias caused by materials used to monitor halocarbons in groundwater. *Environ. Sci. Technol.* **24**:135-142.
112. Rhodes, F.H. and J.T. Carty. 1925. The corrosion of certain metals by carbon tetrachloride. *Ind. Eng. Chem.* **17**:909-911.
113. Rivett, M., S. Feenstra, and J. Cherry. *Field experimental studies of a residual solvent source emplace in the groundwater zone*. In *Petroleum Hydrocarbons and Organic Chemicals in Ground Water*. 1991. National Water Well Association: Houston.
114. Rivett, M.O., S. Feenstra, and J.A. Cherry. *Groundwater zone transport of chlorinated solvents: A field experiment*. In *Modern Trends in Hydrogeology*. 1992. IAH: Hamilton, Ontario, Canada.
115. Rusling, J.F., C.L. Miaw, and E.C. Couture. 1990. Electrocatalytic dehalogenation of α -haloacetic acids by Vitamin B₁₂. *Inorg. Chem.* **29**:2025-2027.

116. Schlegel, H.G., *General Microbiology*. 6 ed. 1986, Cambridge University Press: Cambridge.
117. Schneider, Z. and A. Stroinski, *Comprehensive B₁₂*. 1987, Walter de Gruyter: New York.
118. Schrauzer, G.N. and R.N. Katz. 1978. Reductive dechlorination and degradation of Mirex and Kepone with Vitamin B₁₂. *Bioinorg. Chem.* **9**:123-143.
119. Schwarzenbach, R.P., R. Stierli, K. Lanz, and J. Zeyer. 1990. Quinone and iron porphyrin mediated reduction of nitroaromatic compounds in homogeneous aqueous solution. *Environ. Sci. Technol.* **24**:1566-1574.
120. Senzaki, T. 1991. Removal of chlorinated organic compounds from wastewater by reduction process. III. Treatment of trichloroethylene with iron powder. *Kogyo Yosui.* **391**:29-35.
121. Senzaki, T. and K. Yasuo. 1988. Removal of chlorinated organic compounds from wastewater by reduction process. I. Treatment of trichloroethylene with iron powder. *Kogyo Yosui.* **357**:2-7.
122. Senzaki, T. and K. Yasuo. 1989. Removal of chlorinated organic compounds from wastewater by reduction process. II. Treatment of trichloroethylene with iron powder. *Kogyo Yosui.* **369**:19-25.
123. Silverman, M.P. and D.G. Lundgren. 1959. Studies on the chemoautotrophic iron bacterium *Ferrobacillus ferrooxidans*. I. An improved medium and a harvesting procedure for securing high cell yields. *J. Bacteriol.* **77**:642-647.
124. Smentkowski, V.S., C.C. Cheng, and J.T.J. Yates. 1990. The interaction of carbon tetrachloride with Fe(110): A system of tribological importance. *Langmuir.* **6**:147-158.

125. Soares, M.I.M., S. Belkin, and A. Abeliovich. 1989. Clogging of microbial denitrification sand columns: gas bubbles or biomass accumulation? *Z. Wasser-Abwasser-Forsh.* **22**:20-24.
126. Spiro, M., *Heterogenous catalysis of solution reactions*. In *Chemical Kinetics*, R.G. Compton, Editor. 1989, Elsevier: Amsterdam. pp. 69-166.
127. Starr, R.C., J.A. Cherry, and E.S. Vales. *A new type of steel sheet piling with sealed joints for groundwater pollution control*. In *45th Canadian Geotechnical Conference*. 1992. Toronto, Ontario, Canada
128. Steigerwald, R.F. 1968. Electrochemistry of corrosion. *Corrosion.* **24**:1-10.
129. Stern, M. and H.H. Uhlig. 1953. Mechanism of reaction of aluminum and aluminum alloys with carbon tetrachloride. *J. Electrochem. Soc.* **100**:543-551.
130. Stone, A.T. and J.J. Morgan, *Kinetics of chemical transformation in the environment*. In *Aquatic Chemical Kinetics*, W. Stumm, Editor. 1990, Wiley: New York. pp. 1-41.
131. Stromeyer, S.A., W. Winkelbauer, H. Kohler, A.M. Cook, and T. Leisinger. 1991. Dichloromethane utilized by an anaerobic mixed culture: acetogenesis and methanogenesis. *Biodegradation.* **2**:129-137.
132. Stumm, W., *Chemistry of the Solid-Water Interface: Processes at the Mineral-Water and Particle-Water Interface of Natural Systems*. 1992, Wiley: New York.
133. Sweeny, K.H. *Reductive degradation treatment of industrial and municipal wastewaters*. In *Water Reuse Symposium, vol. 2*. 1979. Am. Water Works Assoc. Res. Found. pp. 1487-1497
134. Sweeny, K.H. 1981. The reductive treatment of industrial wastewaters. II. Process applications. *AIChE Symp. Ser.* **77**:72-78.

135. Sykes, R.M. 1972. Accumulation of methanogenic substrates in CCl_4 inhibited anaerobic sewage sludge digester cultures. *Water Res.* **6**:41-55.
136. Thiel, P.A. and T.E. Madey. 1987. The interaction of water with solid surfaces: Fundamental aspects. *Surf. Sci. Reports.* **7**:211-385.
137. Tratnyek, P.G. and N.L. Wolfe. 1993. Oxidation and acidification of anaerobic sediment-water systems by autoclaving. *J. Environ. Qual.* **22**:375-378.
138. Traunecker, J., A. Preuss, and G. Diekert. 1991. Isolation and characterization of a methyl chloride utilizing, strictly anaerobic bacterium. *Arch. Microbiol.* **156**:416-421.
139. van Damme, H., M. Crespin, G. Obrecht, M.I. Cruz, and J.J. Fripiat. 1978. Acid-base and complexation behavior of porphyrins on the intracrystal surface of swelling clays: Meso-tetraphenylporphyrin and meso-tetra(4-pyridyl)porphyrin on montmorillonites. *J. Colloid Interfac. Sci.* **66**:43-54.
140. van den Hul, H.J. and J. Lyklema. 1968. Determination of specific surface areas of dispersed materials. Comparison of the negative adsorption method with some other methods. *J. Am. Chem. Soc.* **90**:3010-3015.
141. Vogel, T.M., C.S. Criddle, and P.L. McCarty. 1987. Transformations of halogenated aliphatic compounds. *Environ. Sci. Technol.* **21**:722-736.
142. Vogel, T.M. and P.L. McCarty. 1987. Abiotic and biotic transformations of 1,1,1-trichloroethane under methanogenic conditions. *Environ. Sci. Technol.* **21**:1208-1213.
143. von Wolzogen Kuhr, C.A.H. and L.S. van der Vlugt. 1934. Graphitization of cast iron as an electro-biochemical process in anaerobic soils. *Water (The Hague)*. **18**:147-165.

144. Wackett, L.P., M.S.P. Logan, F.A. Blocki, and B.-L. Cai. 1992. A mechanistic perspective on bacterial metabolism of chlorinated methanes. *Biodegradation*. **3**:19-36.
145. Wade, R.S. and C.E. Castro. 1973. Oxidation of heme proteins by alkyl halides. *J. Am. Chem. Soc.* **95**:231-234.
146. Wade, R.S. and C.E. Castro. 1973. Oxidation of iron(II) porphyrins by alkyl halides. *J. Am. Chem. Soc.* **95**:226-230.
147. Walborsky, H.M. and C. Hamdouchi. 1993. The nature of electron transfer from metal surfaces to the carbon-halogen bond. *J. Am. Chem. Soc.* **115**:6406-6408.
148. Widdel, F. and T.A. Hansen, *Chapter 24. The dissimilatory sulfate- and sulfur-reducing bacteria*. In *The Prokaryotes*, A. Balows, et al., Eds. 1992, Springer-Verlag: New York. pp. 583-624.
149. Wolf, C.R., L.J. King, and D.V. Parke. 1978. The anaerobic dechlorination of trichlorofluoromethane by rat liver preparations in vitro. *Chem.-Biol. Interact.* **21**:277-288.
150. Wolf, C.R., D. Monsuy, W. Nastainczyk, G. Deutschmann, and V. Ullrich. 1977. The reduction of polyhalogenated methanes by liver microsomal cytochrome P450. *Molec. Pharmacol.* **13**:698.
151. Wood, J.M., F.S. Kennedy, and R.S. Wolfe. 1968. The reaction of multihalogenated hydrocarbons with free and bound reduced vitamin B₁₂. *Biochemistry*. **7**:1707-1713.
152. Wood, W.G., Ed. *Metals Handbook*. 5th ed. Vol. 5, Surface Cleaning, Finishing, and Coating. 1982, American Society for Metals: Metals Park, OH.
153. Xun, L., D.R. Boone, and R.A. Mah. 1988. Control of the life cycle of *Methanosarcina mazei* S-6 by manipulation of growth conditions. *Appl. Environ. Microbiol.* **54**:2064-2068.

154. Zehnder, A.J.B. and K. Wuhrmann. 1976. Titanium(III) citrate as a nontoxic oxidation-reduction buffering system for the culture of obligate anaerobes. *Science*. **194**:1165-1166.

155. Zurer, P.S., *News Focus: Industry, consumers prepare for compliance with pending CFC ban*. In *Chemical & Engineering News*, 22 June 1992, p. 7-13.

Vitae

I was born on Mother's Day, May 12, 1963 in Portland, Oregon. Soon after, my family moved to Seattle where I spent most of my childhood. In 1981, desiring to become a doctor (I just didn't know which kind) I enrolled in a Pre-med program at Lewis & Clark College in Portland, Oregon, having received an academic scholarship. After tasting a semester of liberal arts college science, I decided to attend a big state school and began studies in Bacteriology and Public Health at Washington State University. Three and a half years later, having developed a profound interest in microbiology under the guidance of my first mentor (Skip Paznokas) and having won an Elizabeth R. Hall scholarship in my senior year, I earned my B.S. degree and returned to Seattle to seek my fortunes in the field of eukaryotic genetics. Even though my job search did not bear fruit for a year, I spent part of the interim working as a volunteer in the Microbiology and Chemistry laboratories at the Food and Drug Administration in Seattle. There I met new friends and learned new skills (including how to be a "morning person!"). I was still unemployed when my mother and I ventured abroad to Europe, the first time for both of us. Needless to say, we both spent all of our money and caught a bad case of the travel bug! Luckily, I was hired as a research associate at ECOVA Corporation in Redmond, WA, a company that specialized in bioremediation of hazardous-waste contaminated sites. Little did I know at the time, but my career in environmental microbiology had begun. While at ECOVA, I had the good fortune to work with my second mentor (Michael Nelson) who later encouraged me to pursue a graduate degree (I'll get you for this Michael!). I decided to return to Oregon to work towards a Ph.D. in Environmental Science and Engineering at the Oregon Graduate Center. During the numerous years I have spent at the Oregon Graduate Institute I have observed many changes (including the topic of my research), and have met many dear friends. After earning my Ph.D. I plan to continue research in the field of chemical and microbiological transformations of organic contaminants. The first part of that plan promises to be a National Research Council Post-Doctoral Fellow at the Environmental Research Laboratory of the EPA in Athens, GA. Someday, I hope that I will be able to be a mentor to some of the next generation of students entering into this exciting field!