

SANDIA REPORT

SAND89-1955 • UC-411

Unlimited Release

Printed November 1989

The Proto-II X-Ray Facility at the Simulation Technology Laboratory

A User's Manual

Gerald A. Zawadzkas

Prepared by
Sandia National Laboratories
Albuquerque, New Mexico 87185 and Livermore, California 94550
for the United States Department of Energy
under Contract DE-AC04-76DP00789

19980819 128

PLEASE RETURN TO:

BMD TECHNICAL INFORMATION CENTER
BALLISTIC MISSILE DEFENSE ORGANIZATION
7100 DEFENSE PENTAGON
WASHINGTON D.C. 20301-7100

U2372

Issued by Sandia National Laboratories, operated for the United States Department of Energy by Sandia Corporation.

NOTICE: This report was prepared as an account of work sponsored by an agency of the United States Government. Neither the United States Government nor any agency thereof, nor any of their employees, nor any of their contractors, subcontractors, or their employees, makes any warranty, express or implied, or assumes any legal liability or responsibility for the accuracy, completeness, or usefulness of any information, apparatus, product, or process disclosed, or represents that its use would not infringe privately owned rights. Reference herein to any specific commercial product, process, or service by trade name, trademark, manufacturer, or otherwise, does not necessarily constitute or imply its endorsement, recommendation, or favoring by the United States Government, any agency thereof or any of their contractors or subcontractors. The views and opinions expressed herein do not necessarily state or reflect those of the United States Government, any agency thereof or any of their contractors.

Printed in the United States of America. This report has been reproduced directly from the best available copy.

Available to DOE and DOE contractors from
Office of Scientific and Technical Information
PO Box 62
Oak Ridge, TN 37831

Prices available from (615) 576-8401, FTS 626-8401

Available to the public from
National Technical Information Service
US Department of Commerce
5285 Port Royal Rd
Springfield, VA 22161

NTIS price codes
Printed copy: A03
Microfiche copy: A01

SAND89-1955
Unlimited Release

Distribution
Category UC--411

The Proto-II X-Ray Facility
at the Simulation Technology Laboratory

A User's Manual

Gerald A. Zawadzkas
Simulation Operations Division 9343
Sandia National Laboratories
Albuquerque, New Mexico 87185

ABSTRACT

Proto II is a nominal 8 terawatt pulsed accelerator which is available for x-ray effects testing. The purpose of this guide is to serve as a basic source of information for prospective users of Proto II. Enclosed is a discussion of the design and operation of the accelerator and a summary of x-ray environmental data. The guide also contains a description of experimental support facilities, data acquisition and analysis systems and general information for users.

Acknowledgement

The author is indebted to numerous personnel for their assistance in providing, collecting and evaluating the information contained in this report. Particular gratitude is expressed to D. Beutler, J. S. Gustwiller, P. Micono, K. A. Mikkelson, R. O'Rourke, R. B. Spielman and B. Spletzer. Barbara Macias and Walt Nickerson are also thanked for their editorial assistance in the preparation of this manual.

TABLE OF CONTENTS

	PAGE
Section 1. Introduction.....	1
Section 2. The Accelerator.....	2
Section 3. X-Ray Environment.....	9
3.1 Bremsstrahlung Mode.....	9
3.2 Gas-Puff Mode.....	12
Section 4. Facilities.....	14
Section 5. Data Acquisition and Analysis Systems.....	17
5.1 Main Screen Room.....	17
5.2 Waveform Recorders.....	17
5.3 Computers.....	20
5.4 Cable Plant.....	21
5.5 Proto II Local Screen Room.....	23
Section 6. General Information.....	24
6.1 Scheduling.....	24
6.2 Contract Procedures.....	24
6.3 Cost Information.....	25
6.4 Security and Visitor Control.....	25
6.5 Shipping Information.....	26
6.6 Travel Information.....	26
References.....	27
Figure Captions.....	28
Figures.....	29
Distribution.....	47

INTRODUCING PROTO II

A Guide for Users

Section 1. Introduction

Proto II is a high-power, pulsed x-ray simulator. It was designed and constructed by Sandia National Laboratories and is located in the Simulation Technology Laboratory (STL) in Technical Area IV, Kirtland Air Force Base, Albuquerque, NM.

The purpose of the facility is to provide an above-ground source for x-ray radiation effects experiments. This manual serves as a basic source of information for prospective users of Proto II. Section 2 contains a brief discussion of the design and operation of the accelerator. A summary of environmental data is presented in Section 3. Section 4 describes the STL facilities, including geometry of the Proto-II test cell and user support areas. Specific information on screen rooms, instrumentation and data recording capabilities is provided in Section 5. The final section of this manual, Section 6, contains general information such as scheduling and contracting procedures for Department of Energy and Department of Defense organizations and contractors.

The depth of material is sufficient to allow the prospective user to determine the applicability of Proto II to his proposed experiment and to permit irradiation calculations and planning. For the purposes of jointly ascertaining technical feasibility of experiments and providing additional information, technical staff are available. Technician support is also available for assisting in setting up experiments. Initial contact and scheduling arrangements should be made with the Supervisor of the Simulation Operations Division 9343 at (505) 844-7483.

Section 2. The Accelerator

Proto II is a radially converging accelerator originally designed and constructed in the mid-1970's as a prototype for driving inertially-confined fusion targets. Since then it has been modified to operate as a nuclear-effects simulator. By using a bremsstrahlung load it can produce x rays with up to 1.5 MeV end-point energy for electronics vulnerability/survivability tests, and by using an imploding plasma as a load it can generate soft x rays for materials effects testing.

Proto-II power flow starts with eight Marx generators which charge 16 water-insulated capacitors which act as intermediate energy storage elements. Eight electrically triggered gas-insulated switches then transfer the energy through oil-water interfaces into 16 tri-plate, pulse-forming/transmission lines. As the energy approaches the diode a convolute section reconfigures the triplate feed into a five-plate transmission line/transformer which feeds a five-plate water/vacuum interface insulator stack. For the bremsstrahlung load, the five-plate line transforms the output impedance from 0.125 to 0.250 ohms. A conical five-plate magnetically insulated transmission line (MITL) in the vacuum section feeds two nested triax diodes. For imploding plasma loads, the five-plate line is configured to maintain the 0.125-ohm output impedance of the triplate line. Conical MITL's in the vacuum section feed power to the load. Nominal accelerator parameters are given below.

Accelerator Parameters

	<u>Brems</u>	<u>Plasma</u>
Peak Diode Voltage	1.5 MV	1.4 MV
Peak Diode Current	3.5 MA	6.5 MA
Power Pulsewidth (FWHM)	40 ns	40 ns

2.1 Overall Design¹

An artists drawing of Proto II is shown in Fig. 1. The center 26 ft. diameter tank, water filled, contains the pulse forming lines, fast switches, transmission lines, and diodes. The Marx generators and intermediate water storage capacitors are located in an oil filled annulus formed between this tank and the outer 50 ft. diameter tank. Both tanks are 12 ft. high with 4 ft. diameter high voltage feedthroughs located at eight evenly spaced locations around the inner tank circumference.

When the eight Marx generators are charged to the appropriate voltage, signals from four low-jitter, 400 kV sources are used to trigger the first row of each generator.

The eight Marx generators then charge a total of 16 intermediate, water dielectric, storage capacitors with a typical $V = V_0 (1 - \cos \omega t)/2$ waveshape. When these water capacitors are about 70% charged, eight trigatron-type gas switches connecting the capacitors to the feedthroughs are triggered. The energy then passes through the interfaces into the water tank charging the first set of pulse forming lines around the tank circumference in 200 ns. Circumferential interconnections between pulse forming lines smooth out voltage transients and provide a uniform voltage waveform. These lines then self-break into a second set of lines via 80 water spark channels. The second set is charged in 50 ns, and the second switch breaks with 112 channels. The launched wave now travels down the converging transmission line transformers into the diode region.

2.2 Marx Generators

The primary energy stores for Proto II are eight parallel, oil-insulated Marx generators. Each generator consists of thirty-two 0.7- μ F, 100-kV capacitors arranged in 4 rows of 8 capacitors, with 16 triggered midplane, SF₆ insulated spark gap switches, and can store up to 112 kJ at 3.2 MV. Bipolar d.c. charging is utilized to minimize the number of spark

gaps and to allow the midplane electrodes to be biased at ground potential. Copper sulfate solution resistors are used throughout the generator for the charging, trigger and ground.

Triggering of the generators is accomplished by applying a fast rise-time, 400 kV pulse to the four spark gap switches in the first row of each generator. The remaining switches are provided a trigger voltage by connecting the midplane trigger electrodes to previous stages in the generator by means of resistors. The erection time of the Marx generators is about 200 ns with a standard deviation of 30 ns.

2.3 Water Capacitors

Eight pairs of 7.5-nF water capacitors are used as intermediate energy stores on Proto II. Electric field strengths on the inner and outer cylinder for a 3-MV charge are 0.23 MV/cm and 0.135 MV/cm, respectively, permitting 36 kJ to be stored in a relatively low-inductance configuration.

2.4 SF₆ Gas Switch

Energy is transferred from the water capacitors to the first set of lines through eight, triggered SF₆-insulated gas switches. Triggering of the switches is accomplished with a +200-kV fast risetime pulser applied to a pin in the negative electrode. The trigger pulse is fed to the switch through a 10- μ H inductor which holds the trigger pin at ground potential during the charging of the water capacitor. The capacitance of the pulse-forming lines holds the electrode at ground.

2.5 Water-Insulated Lines

The output from each set of water storage capacitors is fed through the trigatron switch and the oil/water interface to two sets of lines. The stray capacity in each of the eight interfaces and feed is approximately 1.5 nF.

In the design of short pulse duration, low impedance water lines, the key to success lies in minimizing stray capacities and rapidly charging the self-breaking water switches. The rapid charging (30 to 300 ns) reduces the jitter in breakdown times to an acceptable fraction of the pulse width which allows many lines to be fired in parallel and also minimizes the potentially severe (20 to 50 percent) energy losses in forming the spark channels in the gaps. Since the capacitance of line 1 is small (6 to 8 nF) for short pulse duration accelerators, the effect of the 1.5 nF strays is more severe than it is for longer pulse devices. The capacitance across the water switch gaps are minimized since it can cause a prepulse which degrades the performance of the next component in the network. Therefore, prepulse isolation switches are incorporated into the transmission lines.

The time delay between the first and last output pulse from the 16-pulse forming lines also increases the effective risetime and pulse width at the diode. Consequently, minimizing the total jitter between the trigger signals to the eight gas switches (the last triggered stage of the accelerator) and the output pulse is important. The spread from the first to the last pulse for sixteen lines is typically 13 ns, with a jitter of 4.3 ns. The output waveform has a 10 to 90 percent risetime of ~24 ns.

2.6 Triplate/Diode Interface²

Figure 2 illustrates the crossover network, the transformer section, and the insulator stack which comprise the triplate transmission lines - diode interface. The crossover network accomplishes the transition from two output lines (the triplate) to four output lines. The transformer section joins the four output lines to the insulator stack and can be configured either as a 2:1 step-up transformer ($1/4 \Omega$) to drive an electron beam diode (the BREMS mode) or as a matched system ($1/8 \Omega$) to drive imploding gas-puff loads (the PUFF mode). The insulator stacks separate the water lines from the vacuum line/load portions of the accelerator.

2.6.1 Crossover Network

The crossover network provides a transition from the two 16-segment Proto-II output lines to the four output lines which connect to the insulator stack. Angled plates are used to connect the top and bottom ground plates of the 2-line output to those of the 4-line transformer. This results in an electrically "closed" configuration which eliminates any losses due to external stray capacitances. Interleaved stainless steel tubing is used to connect the top and bottom ground plates to the center ground plates of the 4-line transformer.

2.6.2 Transformer Section

The transformer is located between the crossover network and the insulator stacks. It is designed to be operated either as a parallel 4-line $1/8 \Omega$ to $1/4 \Omega$ step-up transformer to drive BREMS, or as a matched ($1/8 \Omega$) array of four parallel transmission lines to drive PUFF. The transformer section is formed from eight trapezoidal aluminum panels which are connected to hinges at the output end of the crossover. Sixteen sets of eight such plates fill the sixteen sectors of Proto II. At the inner radius of the hinged plates, adjustable plates rest on the metal insulator stack endplates and allow for the slight length difference between BREMS and PUFF, plus a small additional tolerance. No special current contact provisions are necessary. The steps in the endplates are arranged to allow sequential fold-up of all eight transformer plates to provide easy access to the water side of the insulator stack.

The transformer input impedance ($1/2 \Omega$ for each of the four lines) is set on an 11.5 cm plate spacing at the attachment point to the crossover. This spacing gives an input impedance in water of 0.51 ohm $\pm 8\%$ per line, or a 0.128-ohm system impedance for 4 lines.

The transformer output impedances are set by positioning of the metal insulator stack endplates on which the hinged transformer plates rest. For the BREMS option, shown in Fig. 3, the addition of two insulators and

gradient rings of the same height to each individual insulator stack "automatically" opens the transmission line spacings to 10.08 cm at the end of the transformer. This spacing gives a mean output impedance per line of 0.92 ohms $\pm 7\%$ at the transformer connection points and 1.13 ohms at the start of the stack flare.

For PUFF, the insulator stack endplates form short 5-cm-spaced transmission lines from the transformer connection point (at radii varying from 68.6 cm to 77.2 cm) inward to the start of the stack flare region at $R = 59.4$ cm. This sets the output impedance per line at 0.46 ohms $\pm 7\%$. At the start of the water flare, the impedances are equal to 0.56 ohms per line.

2.6.3 Insulator Stacks

The insulator stacks for both BREMS and PUFF are designed to operate up to 1.6 MV and 1.2 MV, respectively. The insulator stack endplates extend into the water region and have stepped edges to accept the hinged transformer plates. The inner surfaces of the endplates interface to the vacuum region MITLs.

For BREMS, MITL cones with gravity-held contacts rest on the insulator stack endplates. The four output lines feed a concentric, double cathode diode, with each line feeding one side of the cathode ring. The drop-in gravity-contact design was chosen to provide faster turn around in the BREMS mode. Inner and outer cathode rings are electrically isolated by a groundplane MITL electrode which connects to the anode. In the BREMS mode, the measured current delivered past the vacuum interface at a peak voltage of 1.5 MV at the diode is inner/outer: 1.8/2.2 MA. Peak power is 2.4/3.1 TW. The measured inductances are 9.6/3.0 nH.

For PUFF, four conical MITL's transmit power from the shortened $1/8 \Omega$ insulator stack to the gas-puff load via a double post-hole convolute. See Figs. 10 and 11. In the PUFF mode, measured current delivered past the vacuum interface at peak voltages of 1.2-1.4 MV is 5-6.5 MA. Peak power is 8.0 TW. The measured inductance of the diode is 4.7 nH.

The BREMS and PUFF insulator stacks are designed with many common parts. Changing between BREMS and PUFF tubes involves removing two flat-backed insulators and two secondary flux-excluder gradient rings, changing the center flux-excluder ring, and replacing the stack tie rods with shorter ones. The stack tie rod arrangement allows for subassembly of individual stack units and removal of one to four of the units at a time for stack repairs.

Section 3. X-Ray Environment

Proto II can operate in two different modes to produce either bremsstrahlung radiation with endpoint energies from 0.5 to 1.5 MeV, or soft x rays with line radiation in the 1.0 to 5.0 keV range. The bremsstrahlung radiation is produced with an electron beam diode consisting of two nested triaxial diodes, and the line radiation is generated by imploding plasma loads.

3.1 Bremsstrahlung Mode³

The electron beam diode consists of two vertical triaxial diodes as illustrated in Fig. 3. Power is fed to the diodes by conical magnetically insulated transmission lines (MITL's) in the vacuum section.

The geometry of the water and vacuum sections leads to transit-time isolation of the power flow between each individual diode. The MITL design provides constant impedance feeds to the radius where the perpendicular gap is 1.0 cm, with constant gap feeds from that point to each diode. Vacuum impedances for the constant impedance sections of the MITLs are 6.0, 6.2, 9.2, and 5.0 Ω from top to bottom, with increasing impedance in the constant gap section. In order to balance the inner and outer currents on each diode, the inductance of the two upper MITLs from outside the insulator stack to the diode is balanced at 21.8 nH on each side. The inductance of the two lower MITLs is balanced at 17.4 nH on each side. Fine adjustment of the inductance balance is accomplished by raising and lowering the MITL support rings at the insulator stack.

The cathode area for the inner diode is 32 cm², and 47 cm² for the outer. At peak power A-K gaps ranging from 1.75-4.75 mm are required to achieve the design goals of 2.0 MA at 1.5 MV for each diode.

Various diagnostics were employed to characterize the diode behavior. Current was measured by measuring the resistive voltage drop across a 0.0075-cm stainless steel foil. Voltage was measured by standard V-dot monitors just outside the vacuum-water interface and by graded resistive

voltage divider monitors in the vacuum section. These vacuum voltage monitors (VVMs) had access only to the top and bottom lines. With the MITLs positioned for good radial beam positioning, measured values of 3.0 and 9.6 nH were obtained on short circuit shots. A negative ion spectrometer and CR-39 collecting negative ions behind various thickness filters were also employed on the bottom MITL to verify peak voltage measurements.

Operation of the diode over a range of A-K gaps has been demonstrated, and is summarized in Table 1.

Table 1

Bremsstrahlung diode voltages, as measured with VVM's, for various A-K gap settings.

<u>A-K Gap (mm)</u> <u>Inner/Outer</u>	<u>Voltage (MV)</u>
1.75/1.75	0.5
3.25/3.25	1.0
4.75/4.75	1.5

The upper limit in A-K gaps was determined by loss of beam control as the A-K gaps approached the spacing in the MITLs. The lower limit in A-K gaps was due to plasma closure. Shots taken with 1.5 mm gaps produced very low dose and short circuited before any appreciable energy could be coupled to the diodes. Figure 4 shows typical diode voltage and current waveforms for a 1.0-MV gap setting. A calculated electron spectrum, derived from the voltage and current waveforms in Fig. 4, is shown in Fig. 5.

Radiation fields have been measured using CaF₂ thermoluminescent detectors (TLDs). Peak radiation output parameters over exposure areas of 250 cm² with 2:1 uniformity are shown in Table 2.

Table 2

Peak Voltage (MV)	Pulsewidth (FWHM)	Peak Dose (kRads)	Peak Dose Rate (kRads/s)
1.5	18	35	2.0×10^{12}
1.0	14	30	2.1×10^{12}
0.5	9	2	2.2×10^{11}

In the bremsstrahlung mode the radiation is directed downwards into the test cell located underneath the accelerator. A dome 86 cm in diameter at the base and 19.7 cm in diameter at the converter, illustrated in Fig. 6, allows access to the radiation field. Figure 7 shows isodose contour maps for diode voltages of 1.5, 1.0 and 0.5 MV. The dose listed in the contour maps is in rad(CaF₂). Conversion to rad(Si) is spectrum specific but is approximately 0.75 rad(Si)/rad(CAF₂). More precise values depend on the nature of the current and voltage wave forms and the converter type.

Calculated spectra for the various diode voltages are shown in Fig. 8. The photon spectra were calculated using the ITS Monte Carlo electron/photon transport code with machine current and voltage waveforms as input.

PIN diodes have been used to measure the radiation pulse shape. They were located sufficiently far from the converter to avoid saturation effects, and provide accurate pulse shape information. A typical PIN diode waveform is shown in Fig. 9. Pulse widths for the 4.75/4.75 mm A-K gap setting are typically 18 ns FWHM, decreasing to 9 ns FWHM at the 1.75/1.75 mm A-K setting.

3.2 Gas-Puff Mode⁴

In the gas-puff Z-pinch mode, an annular gas column is injected into a 2-cm long load region using a fast electromechanical gas valve coupled to a Mach 8 nozzle. See Fig. 10, After the gas valve is opened, a pair of multiple-gap UV flash boards preionize the gas. Proto II is fired one microsecond later, delivering the total machine current to the load. The magnetic force associated with the current causes the column to implode and the resulting compression on the cylindrical axis heats the plasma and generates the x-ray output.

In this plasma radiation source (PRS) mode, Proto II can produce up to 120 kJ of soft x rays in a broad spectral band (10-500 eV) by using Xenon. As an intense line source, Proto II can produce tens of kilojoules in the 1-3 keV regime by using other gases. Nominal values for the soft x-ray output of Proto II in the gas-puff mode are given in Table 3.

Table 3

Gas	Spectra (keV)	Energy (kJ)*	Fluence-Area Product(cal)#	F-A Filtered Product (cal)	Max Fluence on 8cm ² (cal/cm ²)	Pulsewidth (ns FWHM)
Ne	1	20	100	56	7	20
Kr	1.7	4	20	16	2	12
Ar	3	4	20	20	2.5	12

*X-ray energy radiated in the keV lines into 4π .

#Into a solid angle of 0.254 sr. (~30° cone)

The development of the Proto-II soft x-ray source has included the achievement of a large area, unfiltered, nearly debris-free capability. We have demonstrated this capability in the testing solar cells and fused silica optical elements. Samples as large as 6" x 6" can easily be fielded at a peak fluence of 0.5 cal/cm². For testing applications where extreme sample cleanliness is required, Sandia has also developed a fluence gradient exposure technique (FGET) capable of producing a linear fluence gradient across a sample surface that can be several inches across. Stress gauge

measurements using gravity and PVDV gauges can also be made. Blow-off measurement techniques are currently being developed to allow determination of direction, composition, and particle size of blow-off material. Near term capabilities are expected to include cryogenic (30°K) and optically clean test environments.

The x-ray diagnostics routinely available on request for Z-pinch experiments are time-resolved bolometers (total and keV x-ray yields), x-ray diodes and photoconducting detectors (x-ray temporal history), and time-integrated crystal spectrographs (850 eV to 5 keV). More sophisticated diagnostics such as time-resolved spectrographs, time-resolved x-ray pinhole cameras, piezoelectric pressure transducers, and optical streak cameras can be provided at additional cost coupled with scheduling constraints.

Proto II presently operates the gas-puff on the topside of the accelerator, within the upper water barrier. See Fig. 11. A cross section and a plan view of the test area is shown in Fig. 12.

Typical spectra generated by the Z-pinches of the various gases are shown in Fig. 13. A typical radiation waveform for a neon shot is shown in Fig. 14.

Diode voltage and current for the gas-puff mode are monitored on every shot with V-dot and Rogowski probes located on the insulator stack. Typical waveforms are shown in Fig. 15.

Section 4. Facilities

A layout of the Simulation Technology Laboratory (STL) building is shown in Fig. 16. In addition to Proto II, STL houses several other simulators, including Hermes III. A brief description of the various user-related facilities is given below.

Exposure Areas - The test area for the Proto-II bremsstrahlung mode is located underneath the accelerator (see Fig. 17). The converter is actually 12 feet above the floor level and is accessed by a 8' x 6', 2-ton lift. The usual test region is within the dome-shaped lower water barrier, as described in Section 3.1. Access to the cell is normally via a stairwell, but larger test objects can be lowered into the cell through a 6' x 8' removable grating.

The exposure cell is a very harsh, high noise environment during the radiation pulse. This is due to the presence of high electric and magnetic fields and x rays during the firing of the machine. The experiment and cables need to be very well shielded. It is recommended that the experimenter's package be enclosed in a Faraday cage. The cabling from the experiment package to the junction box, should be made of a high frequency, continuously shielded, low radiation response cable such as 0.141" copper semirigid coax. In addition, grounding and ground loop considerations are very important to reducing noise problems and should be given careful consideration. It is recommended that external package design, cabling and signal levels be discussed with the DAS coordinator to ensure that noise is kept to acceptable levels.

The test region for the gas-puff mode is on the top side of the diode, inside the upper water barrier which is 40 in. in diameter and 4 ft. tall. Elevation and plan views of the exposure area are illustrated in Fig. 12.

A wide variety of power outlets are available. Faraday cages of various sizes are available for insulating test packages from EMP. Junction boxes for cable connection are located close to the test region. Cable information is described in Section 5.4.

Screen Rooms - STL is equipped with a large Main Screen Room and several smaller local screen rooms. Most of the facility's data acquisition equipment is located in the Main Screen Room. The smaller rooms are for users who will be using their own test equipment or need to be close to the test cell. The Main Screen Room, the local screen rooms and the test cell are all tied together via cable conduits in the building's trench system. More information regarding the screen rooms, the data acquisition equipment and the cable system is provided in Section 5 of this guide.

User Data Analysis Room - The User Data Analysis Room is an area where users can process and analyze test data. This RF-shielded room houses four work stations, each having a high resolution graphics terminal and associated printer linked to the VAX 11/780 located in the Main Screen Room. A 20-page/minute laser printer is also available for quick bulk graphic output. This room is also tied into the facility intercom system.

Dosimetry Laboratory - The dosimetry lab is available to all Proto II users. The laboratory uses the TLD-400 thermoluminescent detector as the standard dosimeter. It is a (0.125- X 0.125- X 0.035-in.) chip of calcium fluoride (manganese-activated) which measures doses from 1 rad (Si) to 10^5 rads (Si). For doses greater than 10^5 rads radiochromic dye film dosimetry is available.

Sandia provides and reads a limited number of dosimeters for the experimenter. The lab operates two computer-controlled Harshaw readers. It takes about 40 seconds to read a single TLD. If one should need a significant number of dosimeters, he should make his requirements known early in order to prepare for the experiment.

The STL dosimetry lab is a satellite of Sandia's Radiation Dosimetry Laboratory which provides dosimetry services to Sandia's accelerator, reactor and radioactive-source facilities. It supports development and characterization of the irradiation facilities and radiation exposure data for experiments. System calibrations are traceable to NBS.

User Test Preparation Bays - Three 9' X 13' bays are available for STL users to prepare their equipment before irradiation. These bays are equipped with work benches, basic test equipment and tools. For preparation of very large assemblies the adjacent General Maintenance Area can also be used.

Machine Shop - A fully-equipped machine shop is located in the low bay. It is operated by STL operations staff and will support minor jobs required by Proto II users. Equipment includes: band saw, Series 1 Bridgeport Mill, Series 2 Bridgeport Mill, drill press, 13" lathe, 17" lathe, grinders, belt-sander, 10-ton press, and a small sheet-metal shear.

Conference Room - A 15' X 20' conference room located next to the Test Prep Bays is available to Proto II users for technical discussions and meetings.

Section 5. Data Acquisition and Analysis Systems

STL has a Main Screen Room, where most of the data acquisition equipment is located, and several smaller "satellite" screen rooms located nearer the accelerators. Proto II's local screen room is located next to the entrance to the Proto II Test Cell.

5.1 Main Screen Room

The STL Main Screen Room is 36' X 62' (2230 sq. ft.) and is laid out as shown in Fig. 18. Electromagnetic interference shielding is above the following minimum levels:

Electric Field	14 kHz	110 dB
Plane Waves	450 MHz	110 dB
Microwave	1-10 GHz	110 dB
Magnetic Field	14 kHz	75 dB

5.2 Waveform Recorders

The Main Screen Room is organized into three separate groupings of waveform recorders (see Fig. 19). Each group is controlled separately by minicomputers to the extent of acquiring data. For cable compensation, data processing, and data analysis the waveforms are transferred to the MicroVAX cluster, also located in the Screen Room. Each group of recorders is essentially dedicated to a single accelerator or group of accelerators. However, if a particular experiment requires more than the dedicated number of channels, a switching matrix allows channels from the other systems to be utilized. The three groupings of recorders are listed below in Table 4.

Table 4

STL Data Acquisition Recorders

<u>Group</u>	<u>Facility</u>	<u>No. of Units</u>	<u>Type</u>	<u>Bandwidth (MHz)</u>	<u>No. of Channels</u>
DAS I	Hermes III	30	Tektronix R7912	500	30
		5	Tektronix 7D20	70	10
		5	LeCroy 9400	125	10
DAS II	Shared	29	Tektronix 7912AD	500	29
		5	Tektronix RTD710	100	10
DAS III	Proto II	30	Tektronix R7912	500	30
		5	Tektronix 7D20	70	10
		5	LeCroy 9400	125	10

High bandwidth capability exists with the R7912's and the 7912AD's. The requirement for long time-windows is met using various "slow" waveform recorders. These include LeCroy 9400's, TEK RTD 710's, and TEK 7D20 plugins in TEK R7903 mainframes, which can be used as single channel high bandwidth oscilloscopes without the plugins.

Recorders can be timed from 10 msec before to 10 msec after any event with 1 nsec accuracy. The "slow" recorders have a pre/post trigger capability which allows simple triggering setups.

Capabilities of the Main Screen Room recorders are summarized in Table 5.

Table 5

STL Waveform Recorder Summary

R7912

Single channel digitizer with 500 MHz mainframe, uses manual plugins
Sweep speeds of 10 ns/div to 10 μ s/div (10 division window)

7912AD

Single channel digitizer with 500 MHz mainframe, uses programmable/
manual plugins
Sweep speeds of 10 ns/div to 20 μ s/div (10 division window)

Manual plugins -

7A19/7A29 - Single channel input @ 500 MHz (50 Ω)
7A24 - Dual channel input @ 350 MHz (50 Ω)
7A26 - Dual channel input @ 200 MHz (1M Ω)
7A13 - Dual channel input @ 100 MHz (1M Ω)

Programmable plugins -

7A29P - Single channel input @ 500 MHz (50 Ω)
7A16P - Single channel input @ 225 MHz (50 Ω /1M Ω)

7D20

Dual channel digitizer with 70 MHz bandwidth, analog add mode

Vertical resolution - 8 bits (1 M Ω)
Maximum sample rate - 25 ns/pt
Record length - 1K

RTD710

Dual channel digitizer with 100 MHz bandwidth, sample rate
switching

Vertical resolution - 10 bits (1 M Ω)
Maximum sample rate - 10 ns/pt
Record length - 16K/32K optional

9400

Dual channel digitizer with 125 MHz bandwidth

Vertical resolution - 8 bits (50 Ω /1M Ω)
Maximum sample rate - 10 ns/pt
Record length - 16/32K optional

5.3 Computers

The Main Screen Room uses distributed data acquisition systems in order to provide fast turn-around time, redundancy and low software development cost. The system consists of two MicroVAX 3600 clustered computers for data analysis and Digital LSI-11 computers for data acquisition. The LSI-11's primary function is to control the instruments for a shot. They set up the instruments for a shot, arm the system and acquire the data from the instruments. After an accelerator shot has been taken, the LSI-11 off-loads the data to the VAX in order to allow the instrument control system to be turned around for the next shot. The off-loading of data from the micros to the mainframe is accomplished by using an Ethernet Network which links the LSI-11's to the VAX. The MicroVAX 3600 then performs the more CPU intensive processing of data, which is mainly the restoration of high frequency signal components lost in transmission over the coax signal cables (software cable compensation), folding in of calibration data, etc. The data resides on the clustered disk drives for further processing by interactive data analysis routines.

The software used in the VAX cluster can be divided into two main categories: system and application software, and data analysis software. The MicroVAXs operate under one cluster operating system which includes various utilities and services. The Data Analysis System has both "off-the-shelf" software and Sandia-developed software. Several interactive waveform data analysis programs are available on the MicroVAXs so that users may choose the one they are most familiar with. In general, these programs provide the usual waveform math (integration, differentiation, least squares fit comparison, multiplication, division, FFT, X vs. Y, etc.) and graphics (windowing, labelling, output, etc.) functions. Waveforms can be manipulated, read from previous shots, saved, deleted, etc., allowing maximum flexibility. Automated data processing which can be run in batch mode is also available.

Current in-house programs available are:

1) IDR (Interactive Data Reduction) This program supports waveform recorders with various record lengths. Waveforms are disk based and accessed by signal name or record number and placed into memory-based working arrays which can then be used for analysis.

2) DAMP (Data Analysis and Manipulation Program) This program is primarily for 7912 waveforms with 512 point records, but it can also support variable length records. All waveforms are memory based, loaded when the shot file is opened and accessed by signal name.

3) IDL (Interactive Data Language) This is a data analysis package written by Research Systems, Inc., for DNA. To provide compatibility with DNA users the standard data formats can be translated to the IDL format.

Data can be taken from STL by the user in the following formats: TK50 tape, 9-track tape, DEC RX50 5-1/4" floppy disk, 8" floppy disk, RL02 disk and IBM PC compatible floppy disks.

The VAX also maintains a database and data analysis software which documents and analyzes accelerator performance history, single shot performance and comments about each accelerator shot. It also contains TLD measurement and reduction software for both tabular and graphic portrayal of accelerator radiation patterns.

The MicroVAX cluster is connected by terminal servers to the microcomputer data acquisition system, the terminals in the data analysis room and the Proto II Local Screen Room (see Fig. 20).

5.4 Cable Plant

The Main Screen Room for STL acquires waveform data for all the accelerators and test cells in the High Bay. The cable system to the High Bay exits the screen room floor and is routed down to the trenches through a cable shaft, a drop of about 18'. The cables are routed to the accelerators

in RFI tight conduits by means of a trench network. The connection from the cable system to experiments at the various accelerators is accomplished by means of junction boxes located in each exposure cell and RG-214 cable jumpers. Each jumper cable is double-shielded with flexible metal hose (breeze tubing) and has either "N" or "HN" type connectors. Other types of connectors can be provided upon request.

The low-loss cable which comprises the bulk of the cable run is 1/2" 50-Ω Heliax foam-dielectric coaxial cable (LDF4-50A). The connectors for the foam cable are both "N" and "HN" type self-flaring design. The cable runs from the exposure cell junction boxes to the top of the cable shaft are continuous with no intermediate splices.

The cable conduits are 12" X 8" square, which allows for a very large capacity of cables from the main screen room to each accelerator. The conduit has a "U"-shaped sectional configuration, capable of a total cable load of 50 pounds per linear foot. The conduits have a cadmium-plated "bolt-together" design with top loading access and a completely un-obstructed smooth interior. All mating surfaces have high quality, low resistance RFI gasketing.

Cable Tray Minimum Attenuation Levels

Electric Field	15 KHz - 10 GHz	>100 dB
Magnetic Field	15 KHz - 1 MHz	~75 dB
	1 MHz - 10 MHz	>100 dB

Eighty (80) 50-Ω coaxial cables are installed between the main screen room and the Proto-II test cell. The length of these cables is 210' (~250 ns) and they are equalized in length to <0.5 ns. The bandwidth of the coaxial cable run is ~250 MHz without frequency-loss compensation applied. With frequency loss compensation applied, the bandwidth is >500 MHz.

The cable plant was designed to meet or exceed the shielding, bandwidth and number-of-test-points requirements. A study of typical signals routed to the Main Screen Room shows that the electrical performance of the cable plant, along with software cable compensation, provides adequate bandwidth to

properly record fast transient signals. In fact, the bandwidth for the data acquisition system is limited only by the maximum bandwidth specifications for the vertical amplifiers used in the transient recorders in the Main Screen Room. The fastest recording instruments are the Tektronix 7912's which have a 500 MHz analog bandwidth (1 ns risetime) with certain plugins.

5.5 Proto-II Local Screen Room

The Proto-II local screen room is a low-noise chamber immediately adjacent to the exposure cell. It was designed for users as a control site for experimental hardware and as a data acquisition site for low level and/or very high-speed signals.

The physical size of the screen room is approximately 8' x 16', with an 9' high ceiling. The access door provides a clear aperture of 40"W x 84"H.

The screen room is a single-wall RFI/EMI shielded enclosure with a rated performance of:

Electric field	14 kHz	~100 dB
Plane waves	450 MHz-1 GHz	~100 dB
Magnetic field	14 kHz	~80 dB
	60 Hz	~12 dB

A single 8" x 8" square cable conduit runs a distance of 22' from the local screen room to the Proto-II exposure area. This is an RFI/EMI-shielded tray with top loading access and an unobstructed interior.

To allow entry of user cables into the screen room, a large junction box interfaces to a 3' x 4' plate on the screen room wall. This plate presently has 20 type-'N' and 10 type-'BNC' feedthroughs. There is an intercom system for communications during tests.

Electrical power available in the Proto-II local screen room consists of 120 VAC, 20A circuits, 208V, 3 ϕ , 20A and 208V, 1 ϕ , 20A services.

Section 6. General Information

6.1 Scheduling

A Proto II experiment should be scheduled well in advance and a test plan submitted at least 30 days prior to the scheduled date. This may be done by contacting the Simulation Operations Supervisor at (505) 844-7483. At the time of scheduling, the availability of required monitoring equipment should be determined, the environmental conditions required by the test should be discussed and any arrangements regarding the services mentioned in this manual should be concluded.

It is strongly suggested that prospective users of Proto II make a preliminary visit to the facility to acquaint themselves with it and to gain first-hand information on the compatibility of experiment and machine.

6.2 Contract Procedure for Non-Sandia Users

The services of Proto II is available to agencies of the Department of Energy (DOE) and the Department of Defense (DOD) and to private corporations having DOE or DOD contracts.

DOE or DOD agencies or contractors desiring to use the Proto II facility are required to establish a contract with the Director of Energy Technologies Division of the Albuquerque Operations Office of the DOE. The complete mailing address is:

Director, Reimbursable & Defense Technologies Division
Department of Energy
Albuquerque Operations Office
P. O. Box 5400
Albuquerque, NM 87115

This contract should be requested only after making full technical arrangements with Sandia National Laboratories.

Preliminary arrangements, including technical information, schedule availability and procedural requirements, are made directly with the Simulation Operations Division (9343) of Sandia National Laboratories. The complete mailing address is:

Supervisor, Simulation Operations Division (9343)
Sandia National Laboratories
P. O. Box 5800
Albuquerque, NM 87185

Telephone contact may be made by calling (505) 844-7483. Following this contact, negotiations with the DOE Albuquerque Operations Office should begin.

6.3 Cost Information

Preliminary cost information can be obtained from the Simulation Operations Supervisor. Firm cost information for non-Sandia users is obtained from the Albuquerque Operations Office of DOE.

Usage of Proto II is charged by the hour. The user is only charged for time when the facility is operational. Set-up time is not charged to the user if it is done outside the test cell, but set-up time in the test cell is charged to the user. Normal hours for users is from 8:00 AM to 4:00 PM, Monday through Thursday. However, other arrangements can be made if required.

6.4 Security and Visitor Control

Unless a user holds a DOE "Q" or DOD "SRD" clearance, it will be necessary for him to be escorted to and from the Hermes III facility, and his movements will be restricted. Security arrangements should be completed at the earliest convenient time but not less than two weeks before any preliminary visit or use of the Proto II machine.

Security arrangements are to be made through Sandia National Laboratories at the following address:

Visitor Access and Administration Section

Division 3434-1

Sandia National Laboratories

P. O. Box 5800

Albuquerque, NM 87185

Telephone: (505) 844-4494

FAX: 846-0274 (to verify, call 844-2269)

6.5 Shipping Information

To avoid any delays in shipment, users are urged to ship materials at least two weeks in advance of the date they will be needed. Address shipments to:

Proto II Facility

Building 970, Tech Area IV

Simulation Operations Division 9343

Sandia National Laboratories

P. O. Box 5800

Albuquerque, NM 87185

6.6 Travel Information

Fig. 21 shows the location of Tech Area IV on the Kirtland Air Force Base. Fig. 22 indicates the location of the Simulation Technology Laboratory (Building 970) within Area IV.

Note that all non-Sandia visitors, before entering Area IV must receive Sandia badges in Area I, Bldg. 802. Upon arrival in Area IV visitors must check in at the Guard Desk in Bldg. 980 or Bldg. 960.

References

1. T. H. Martin, et. al, "Proto-II - A Short Pulse Water Insulated Accelerator," Proc. of 1st International Topical Conference on Electron Beam Research and Technology," Vol. 1, p. 450, February 1976.
2. T. P. Wright, et. al, "Modification of the Proto-II Accelerator Power Flow for Multi-Purpose Use," Proc. of the 5th IEEE Pulsed Power Conference, Arlington, VA, June 1985.
3. M. A. Hedemann, et. al., "Proto II Triaxial Electron Beam Diode Research," Proc. of the 7th IEEE Pulsed Power Conference, June 29-July 1, 1987.
4. R. B. Spielman, et. al., "Efficient X-Ray Production from Ultrafast Gas-Puff Z Pinches," J. Appl. Phys., 57 (3), February 1, 1985.

Figure Captions

- Fig. 1 The Proto-II Accelerator
- Fig. 2 Triplate/Diode Interface
- Fig. 3 Bremsstrahlung Diode
- Fig. 4 Typical Voltage and Current Waveforms for Nominal 1.0 MV diode.
- Fig. 5 Calculated Electron Energy Spectrum
- Fig. 6 Bremsstrahlung Diode Showing Access Dome
- Fig. 7 Isodose Contour Maps for 0.5-, 1.0-, and 1.0-MV Bremsstrahlung Diodes
- Fig. 8 Calculated Photon Spectra for Various Bremsstrahlung Diodes
- Fig. 9 Typical Radiation Waveform for Bremsstrahlung Shot (1.0 MV)
- Fig. 10 Gas-Puff Diode
- Fig. 11 Gas-Puff Diode in Proto II
- Fig. 12 Views of Test Region for Gas-Puff Mode
- Fig. 13 Typical Spectra Generated by Z-Pinches for Various Gases
- Fig. 14 Typical Radiation Pulse Shape for Neon Z-Pinch Shot
- Fig. 15 Typical Diode Voltage and Current Waveforms for a Gas-Puff Shot
- Fig. 16 Layout of STL
- Fig. 17 Layout of Proto-II Test Cell (for Bremsstrahlung mode)
- Fig. 18 Layout of Main Screen Room
- Fig. 19 Photo of Main Screen Room
- Fig. 20 VAX System Layout
- Fig. 21 Location of Tech Area IV on Kirtland Air Force Base
- Fig. 22 Map of Area IV

PROTO II

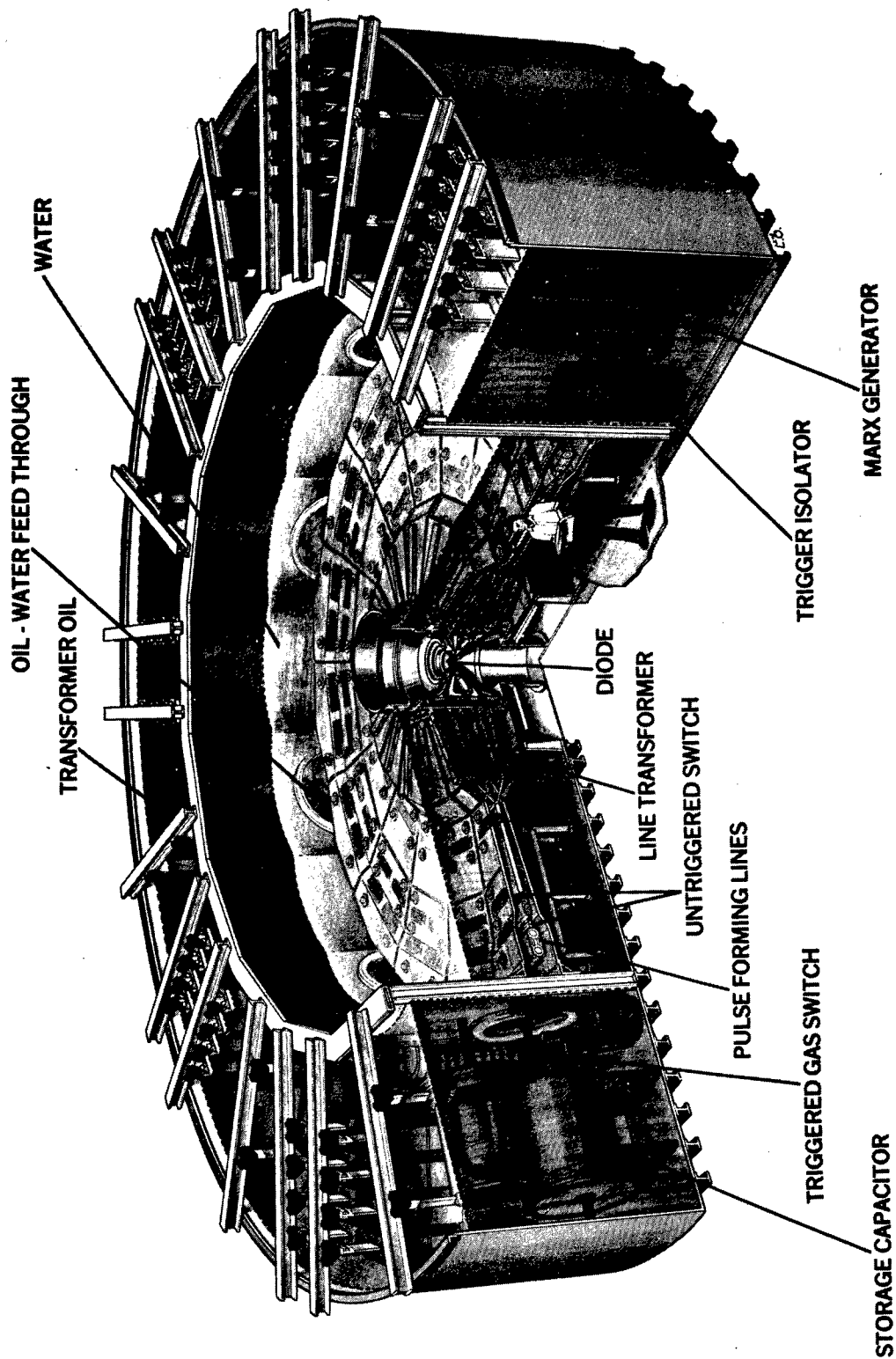

Fig. 1 - The Proto-II Accelerator

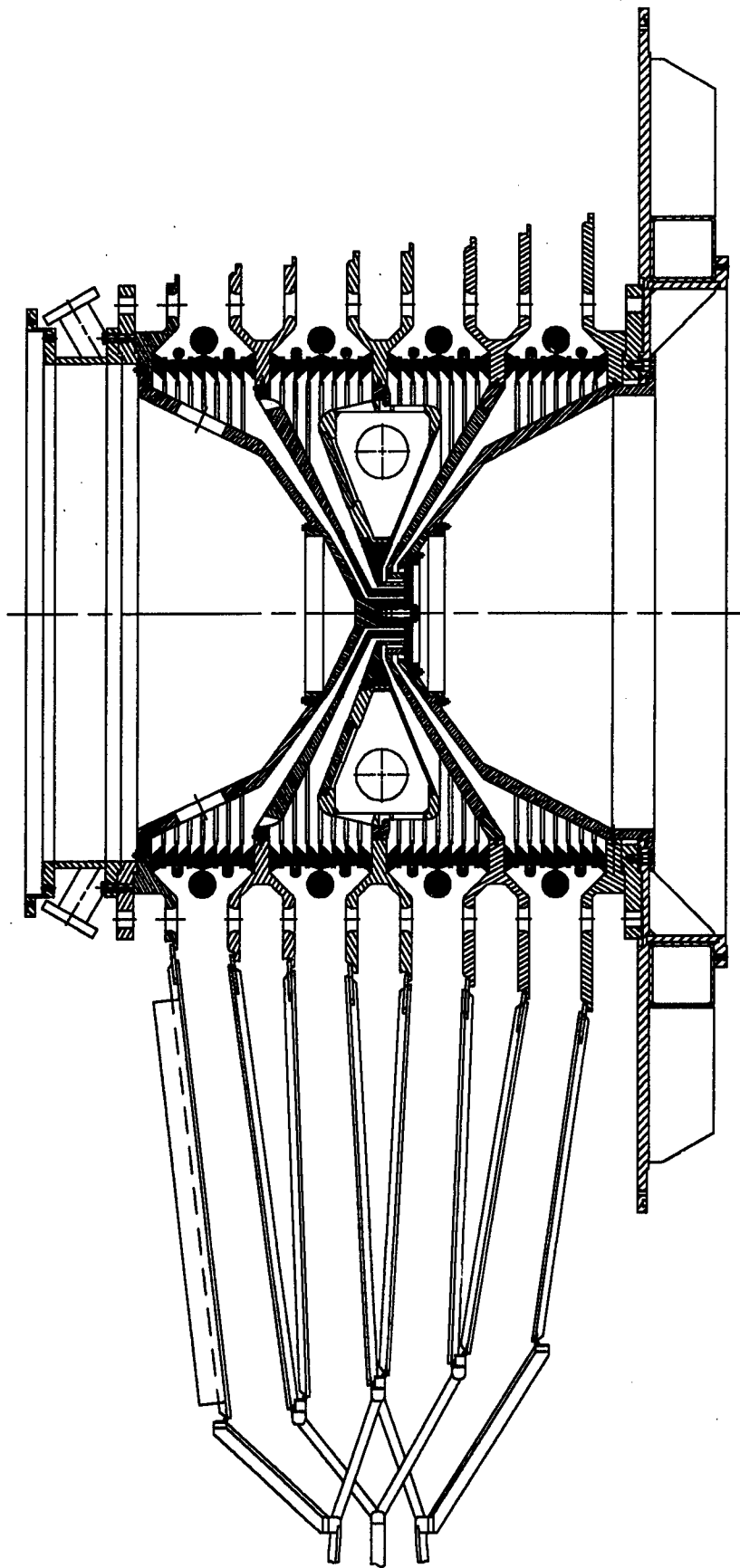

Fig. 2 - Triplate / Diode Interface

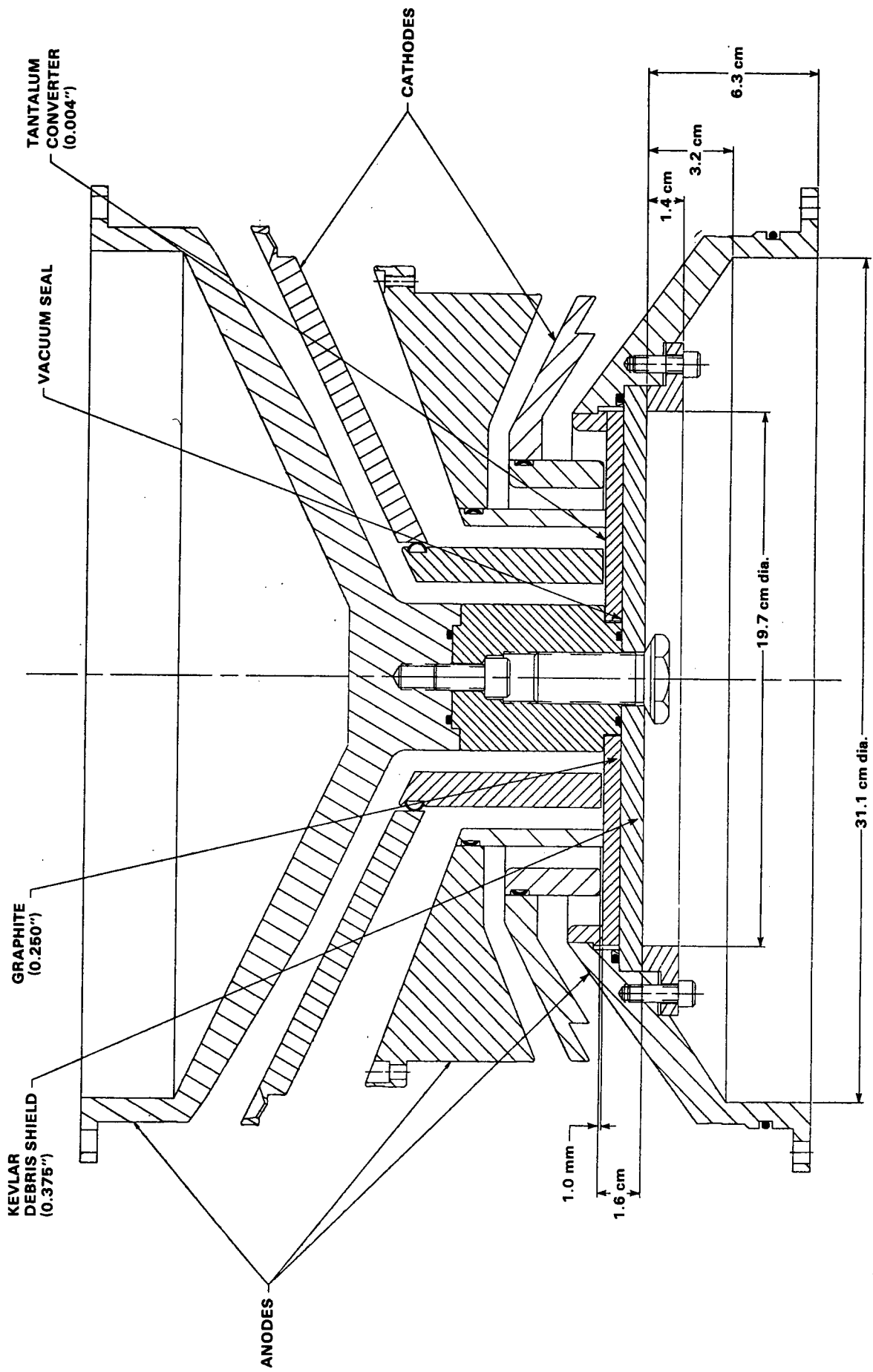

Fig. 3 - Bremsstrahlung Diode

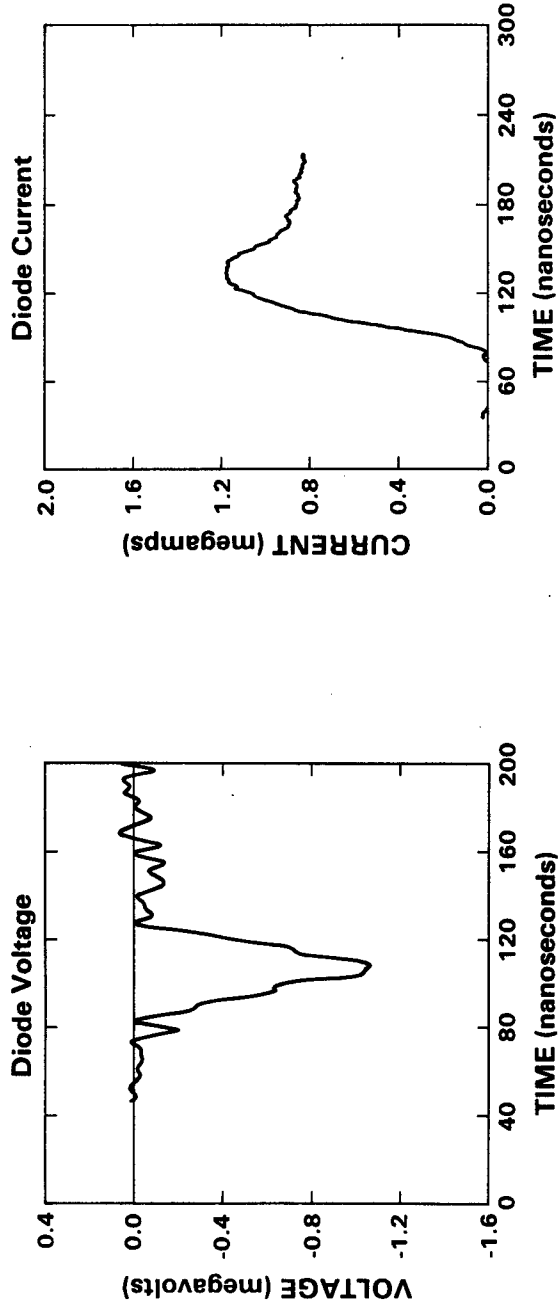

Fig. 4 - Typical Voltage and Current Waveforms for Nominal 1.0 MV diode.

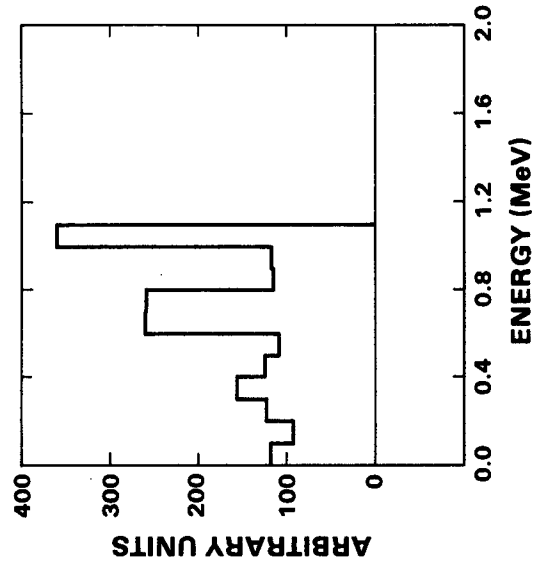

Fig. 5 - Calculated Electron Energy Spectrum

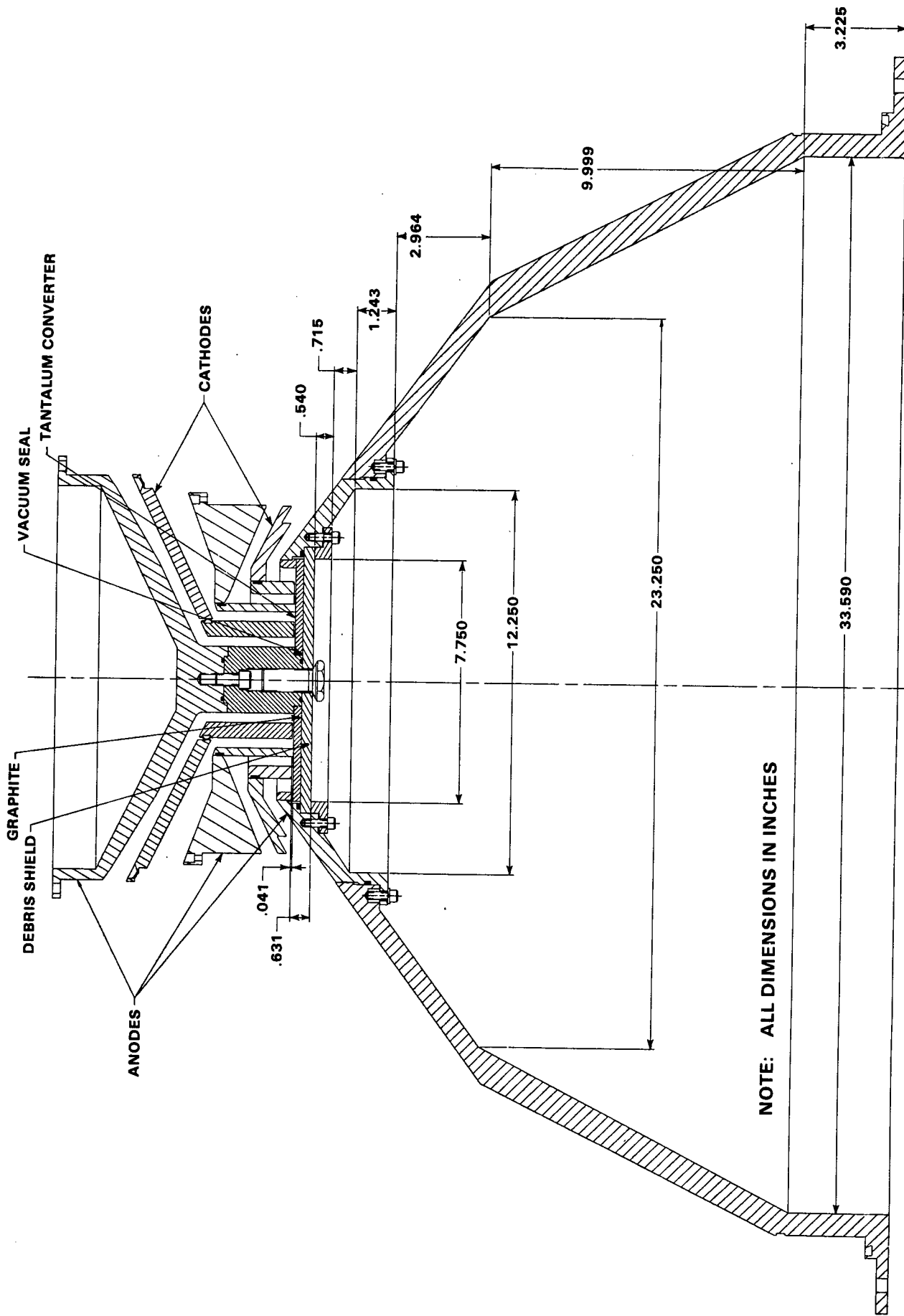
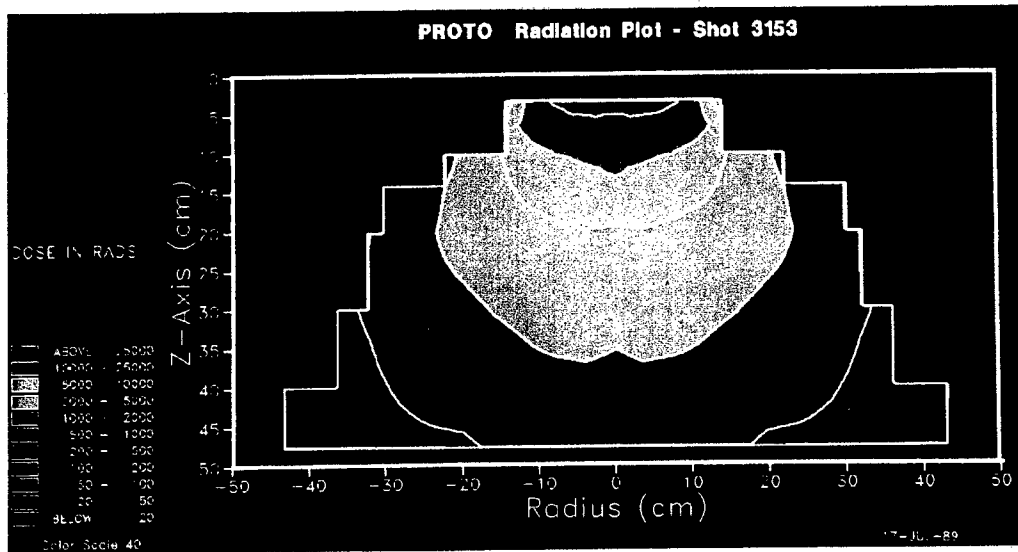
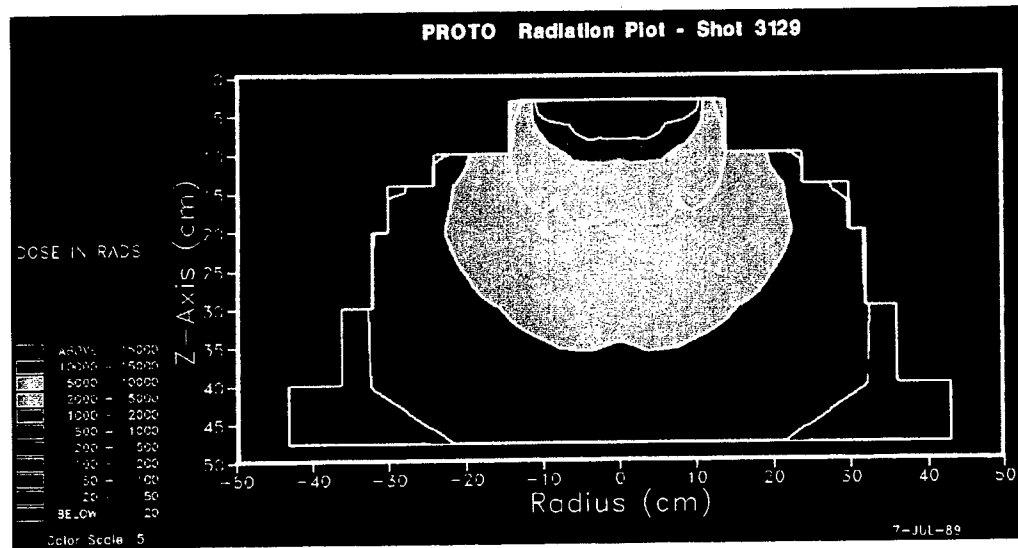

Fig. 6 - Bremsstrahlung Diode Showing Access Dome

1.5 MV



1.0 MV



0.5 MV

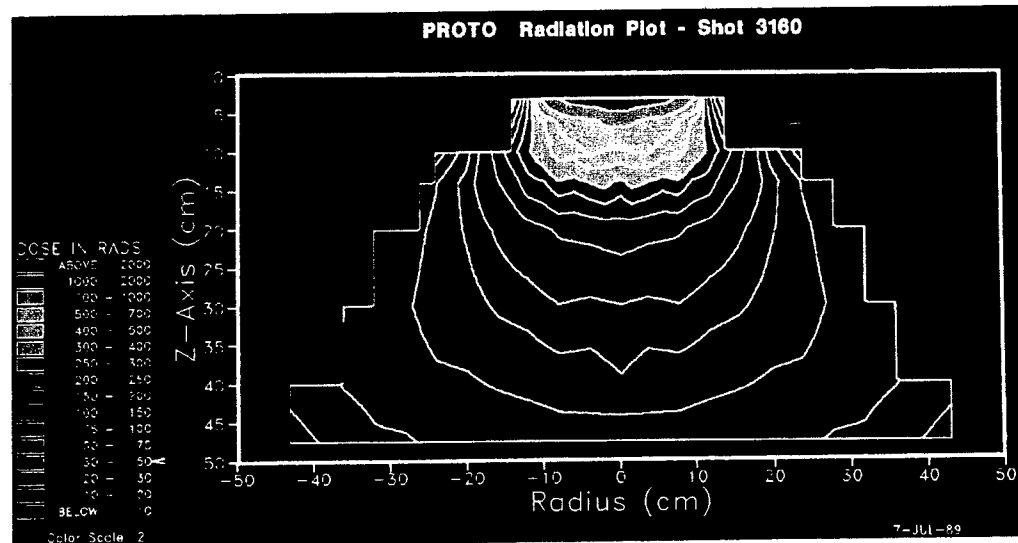

Fig. 7 - Isodose Contour Map for 0.5-, 1.0-, and 1.5-MV Bremsstrahlung Diodes

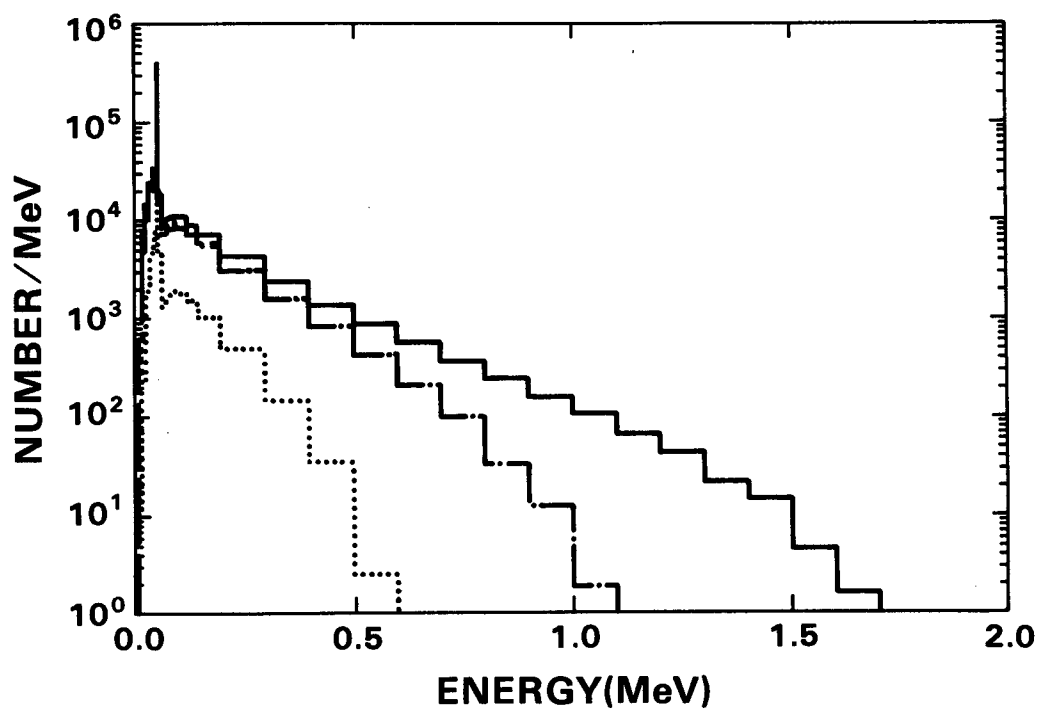

Fig 8 - Calculated Photon Spectra for Various Bremsstrahlung Diodes

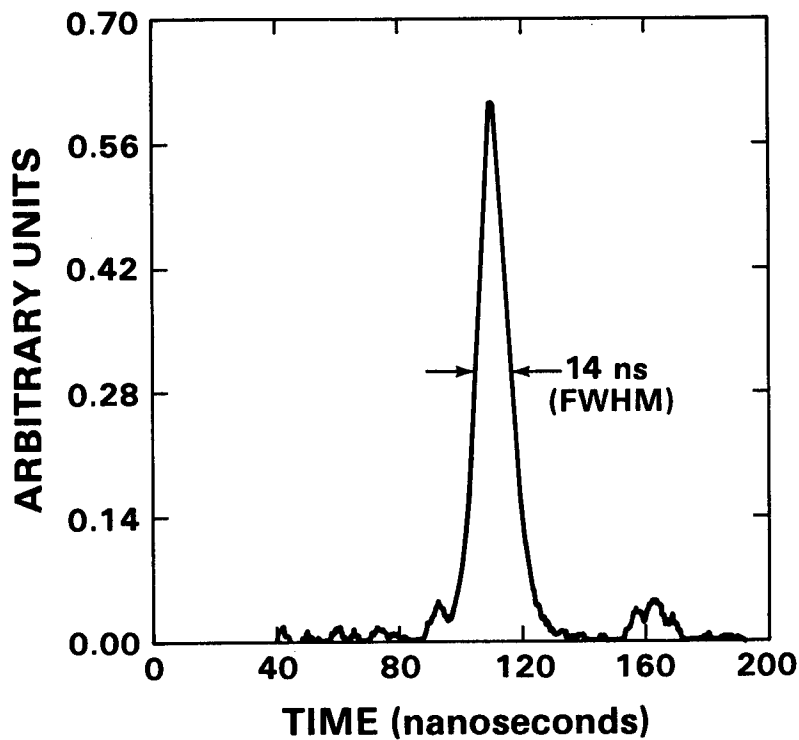

Fig. 9 - Typical Radiation Waveform for Bremsstrahlung Shot (1.0 MV)

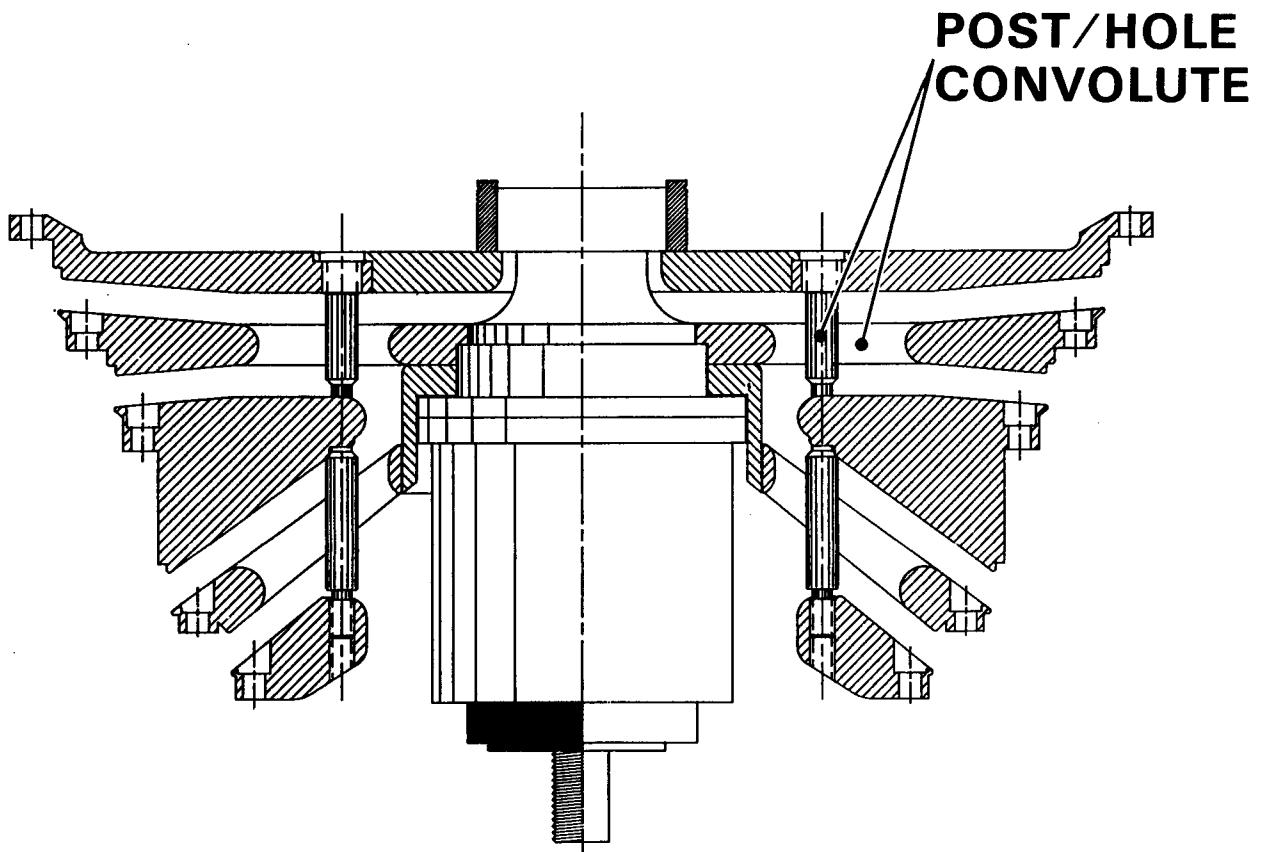
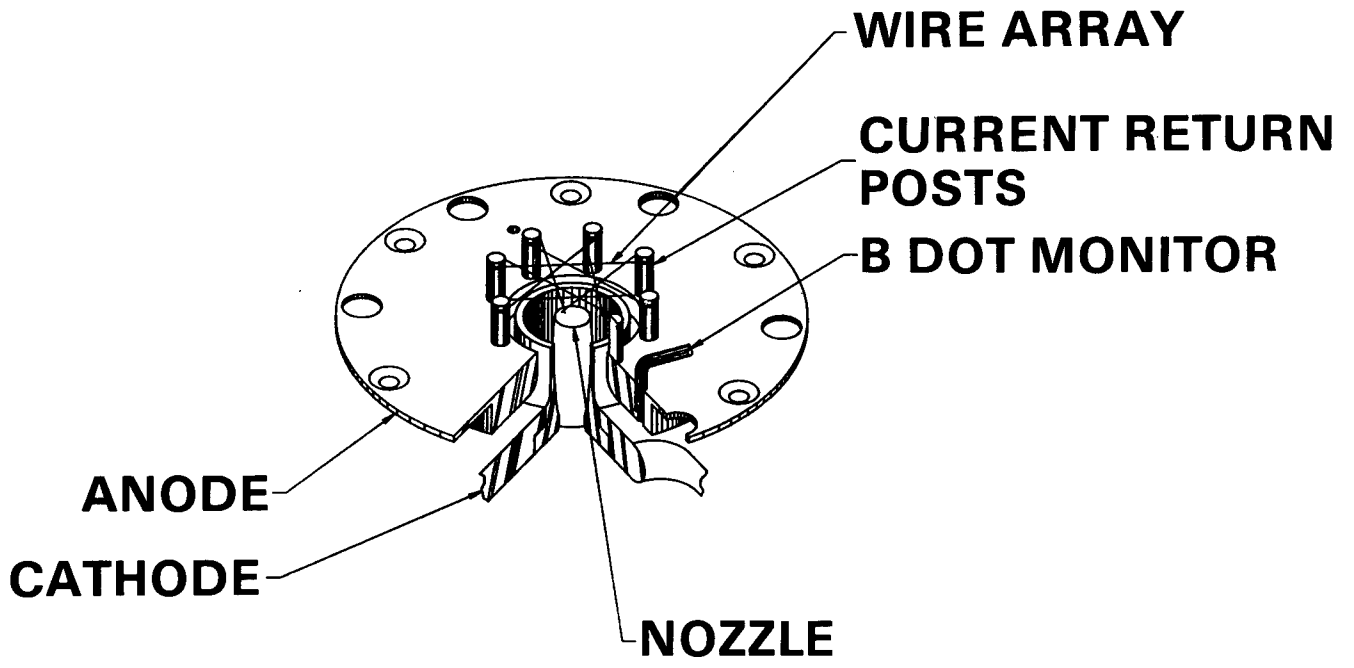

Fig. 10 - Gas-Puff Diode

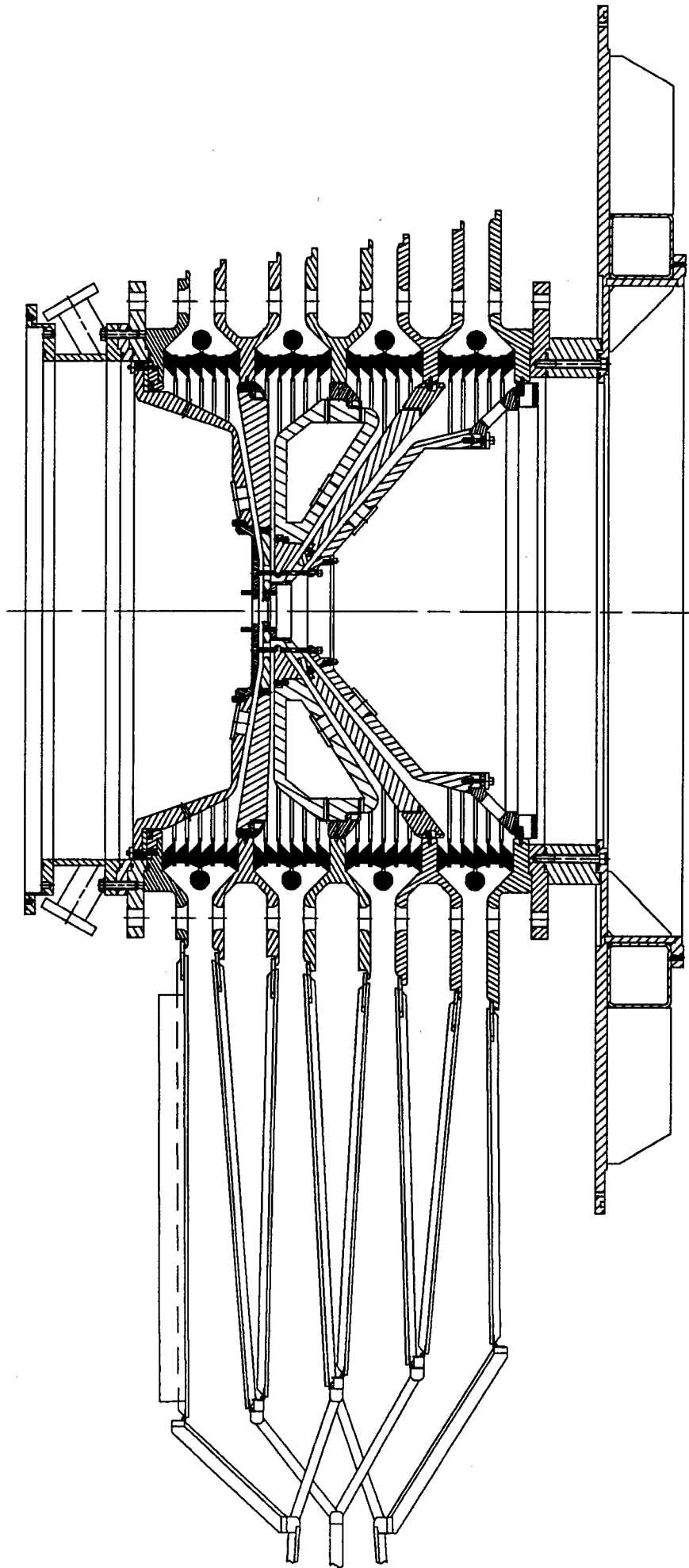

Fig. 11 - Gas - Puff Diode in Proto II

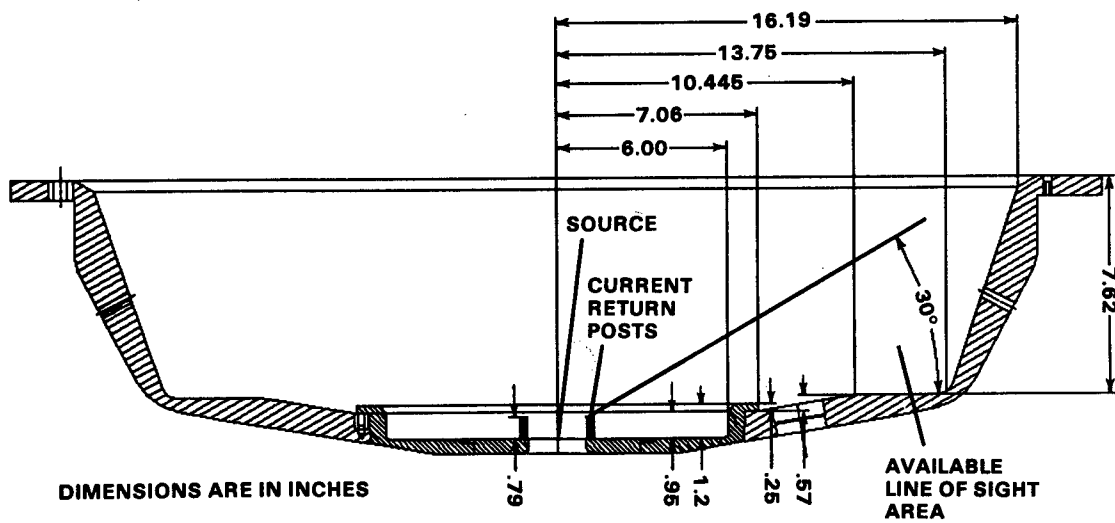
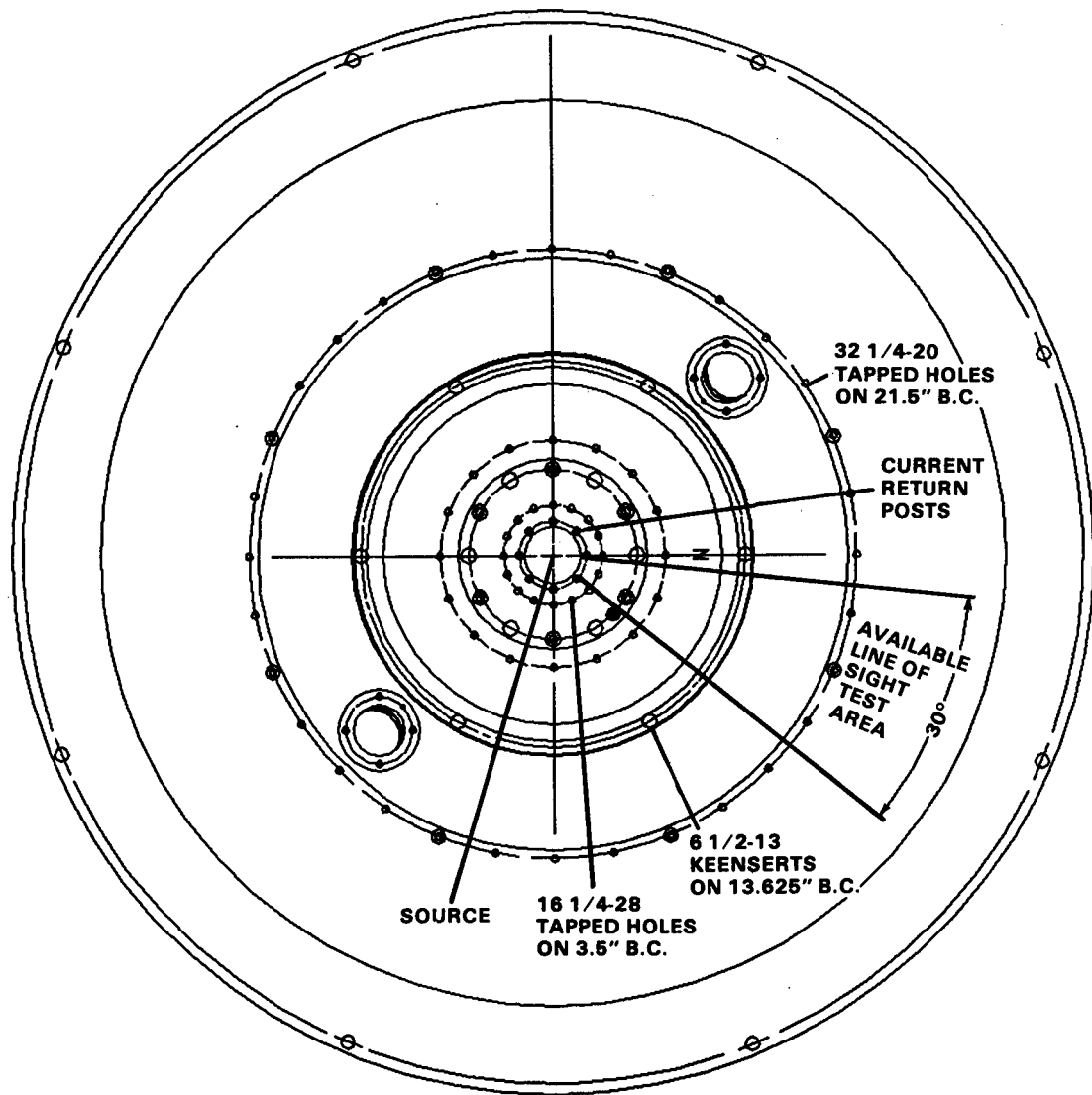

Fig. 12 - Views of Test Region for Gas-Puff Mode

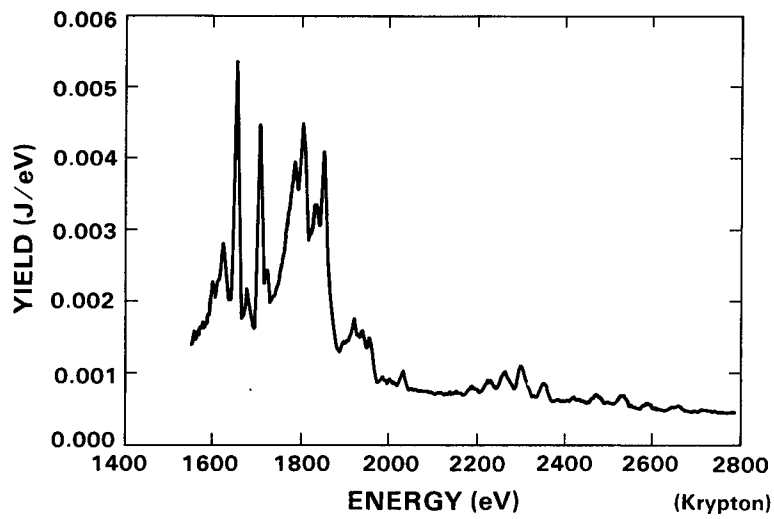
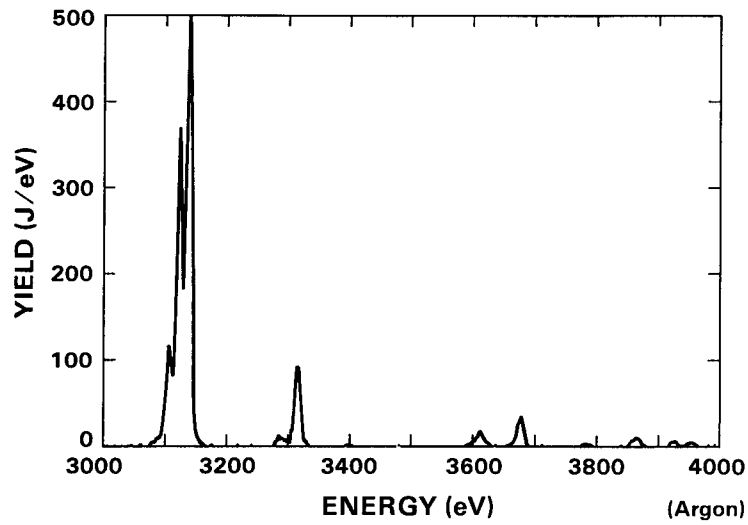
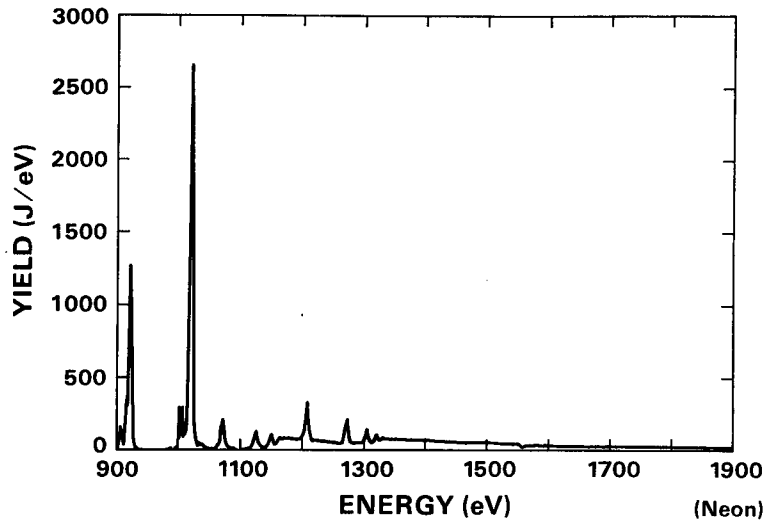

Fig. 13 - Typical Spectra Generated by Z-Pinches for Various Gases

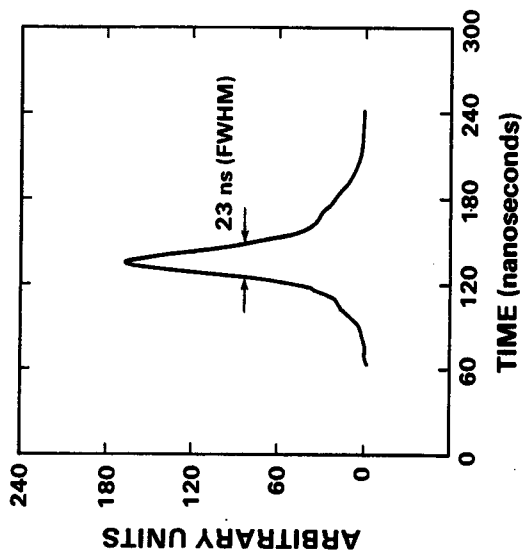

Fig. 14 - Typical Radiation Pulse Shape for Neon Z-Pinch Shot

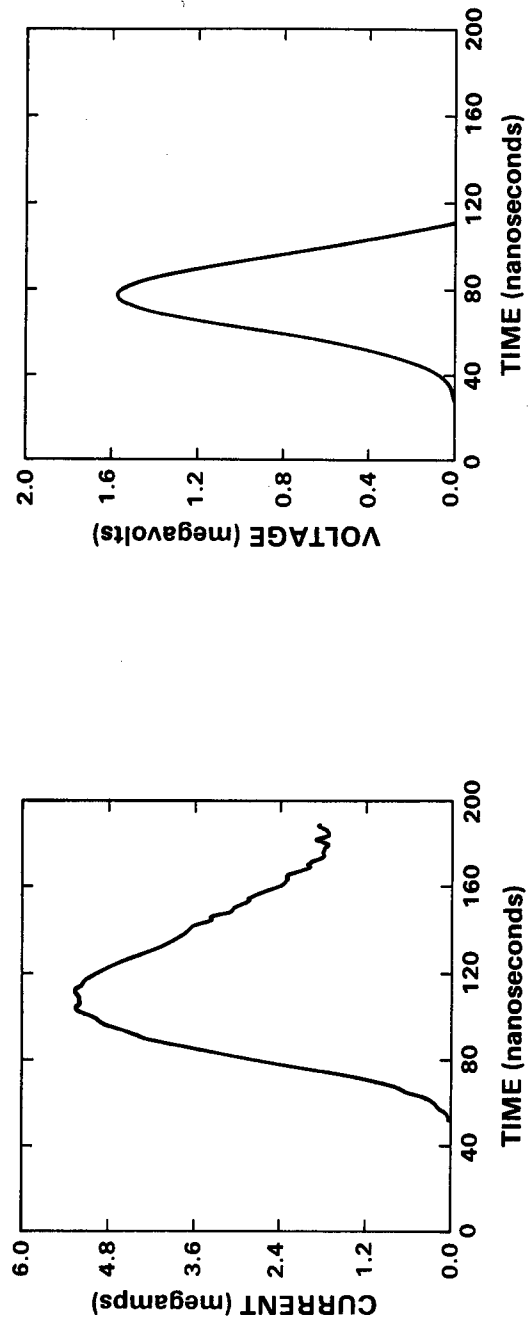

Fig. 15 - Typical Diode Voltage and Current Waveforms for a Gas-Puff Shot

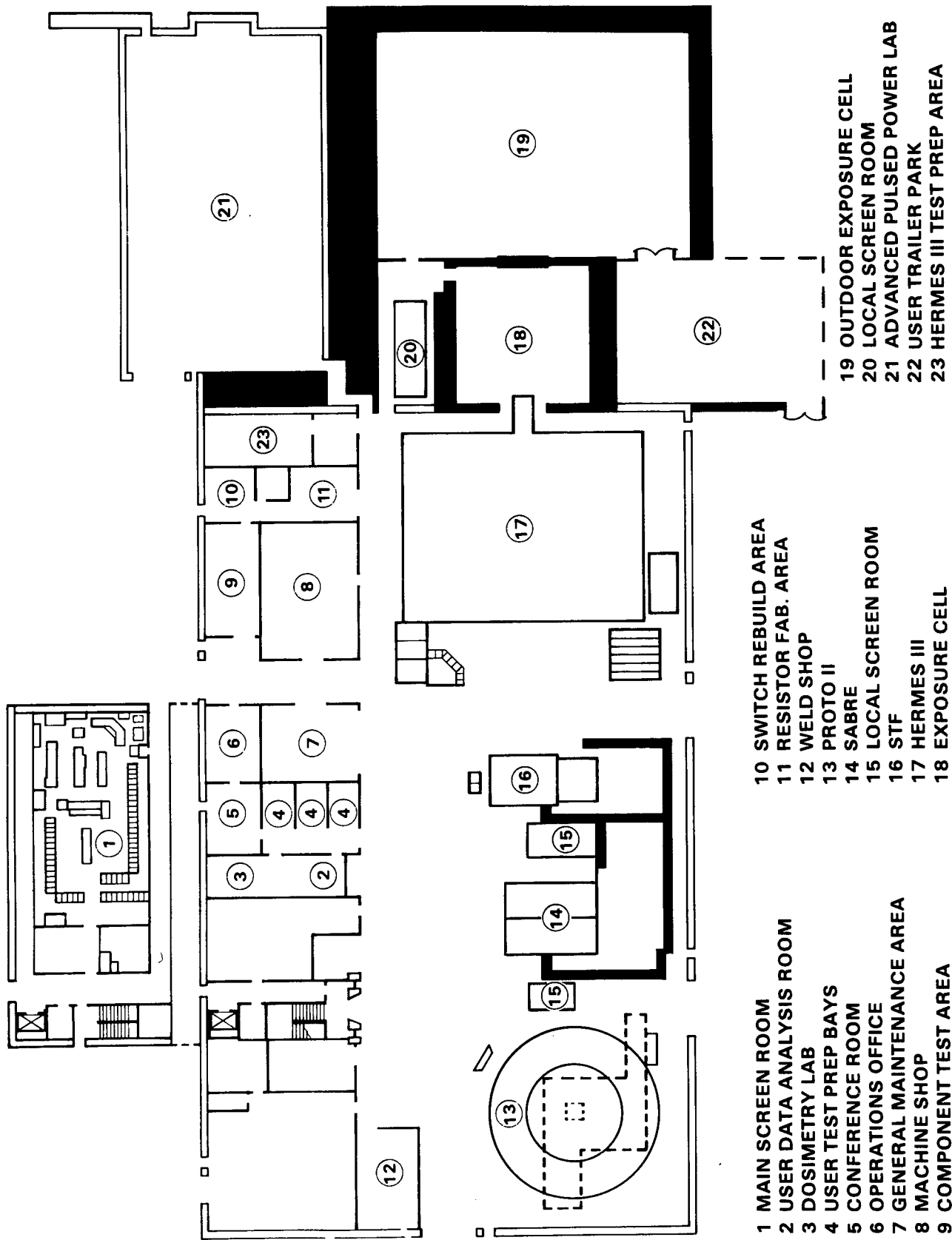

Fig. 16 - Layout of the Simulation Technology Laboratory, Building 970

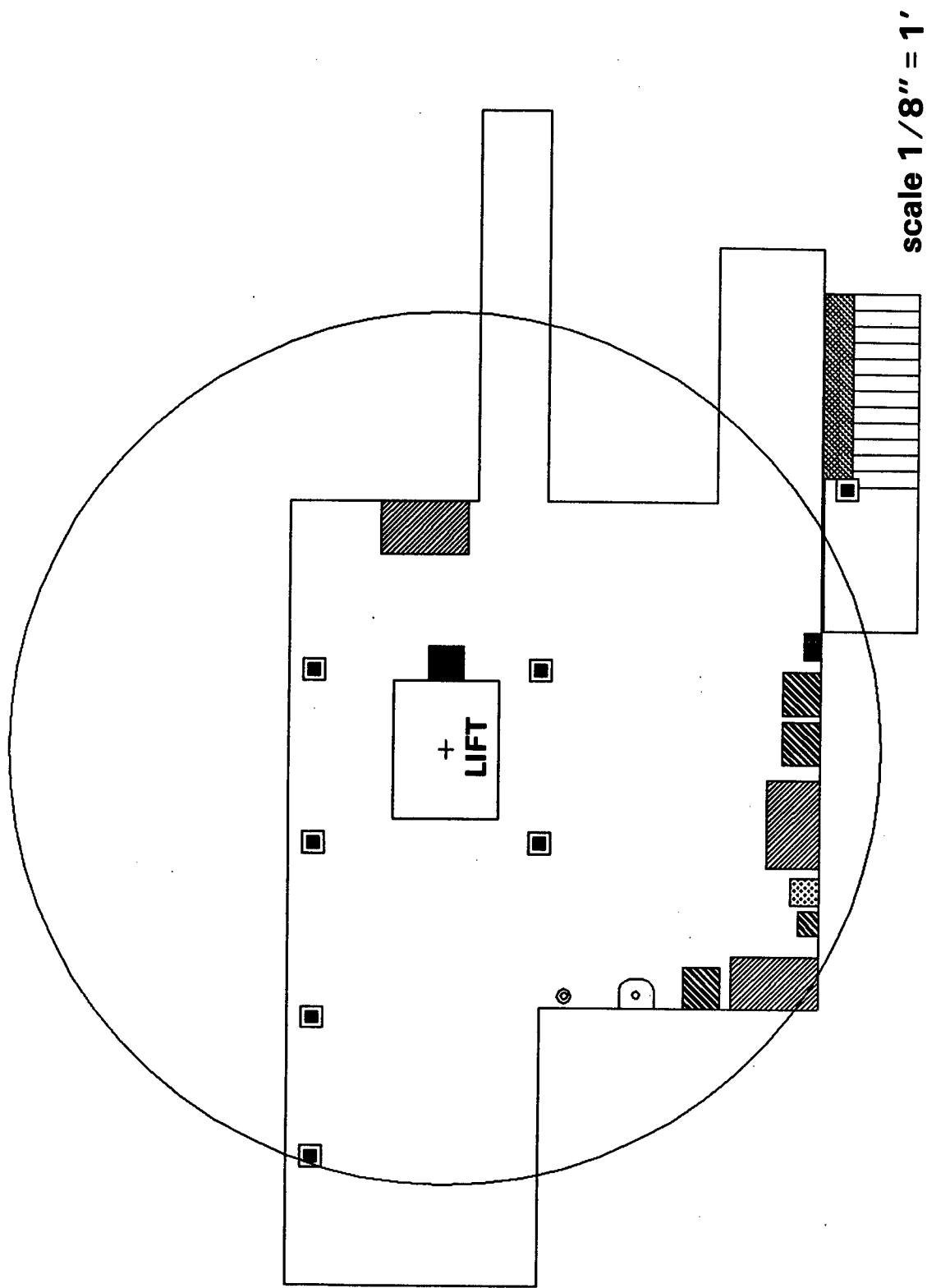

Fig 17 - Layout of Proto-II Test Cell (for Bremsstrahlung mode)

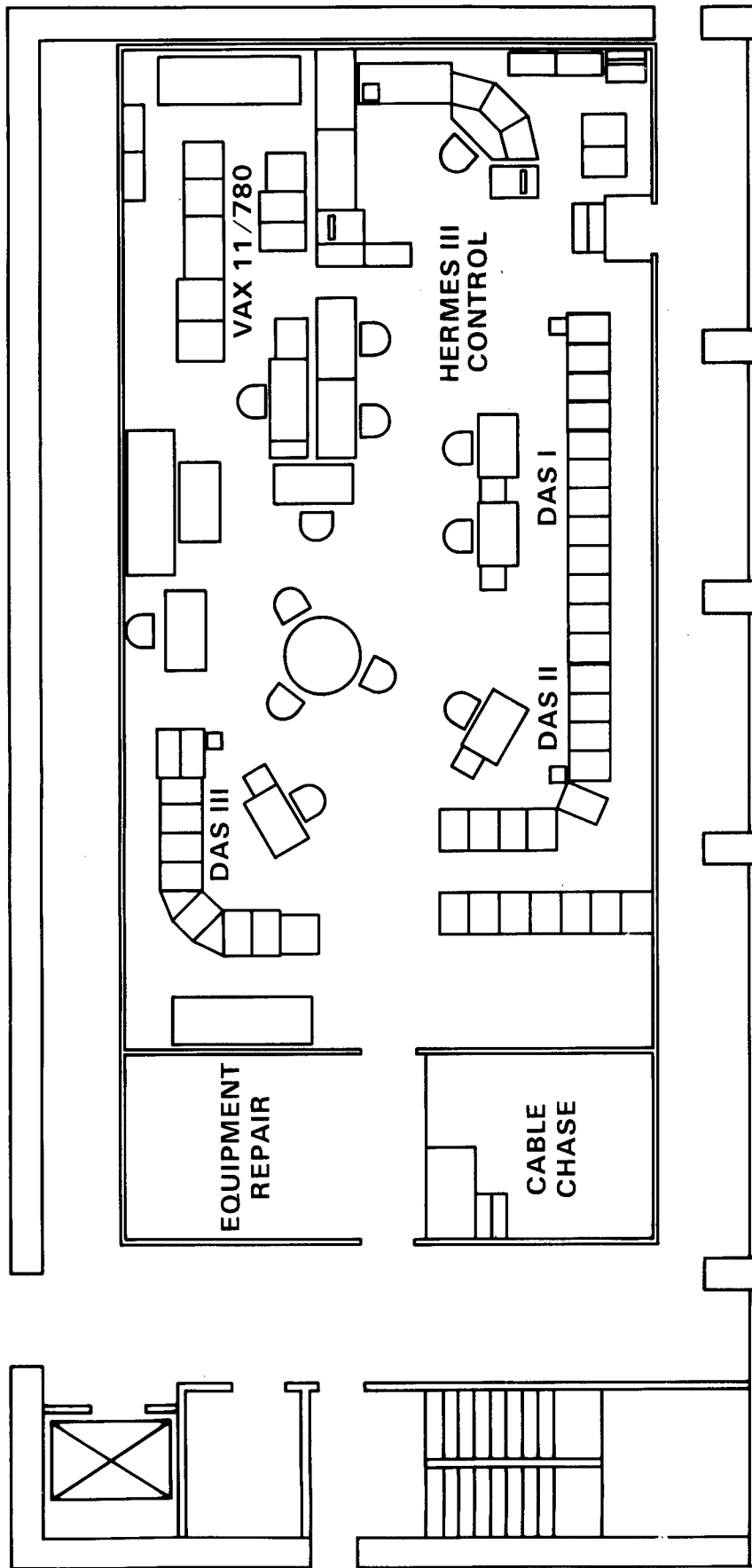

Fig. 18 - Layout of STL Main Screen Room

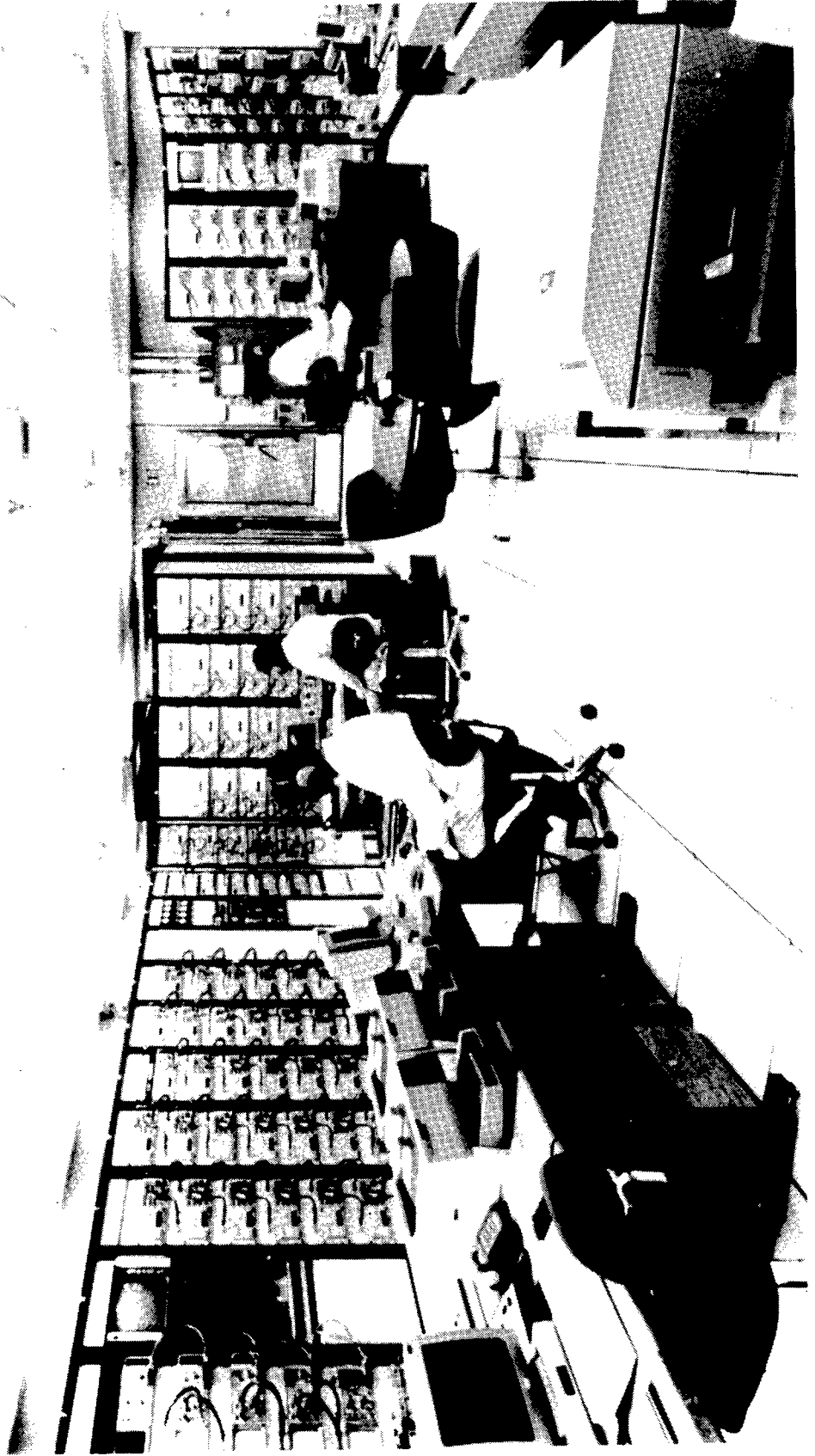

Fig. 19 - STL Main Screen Room

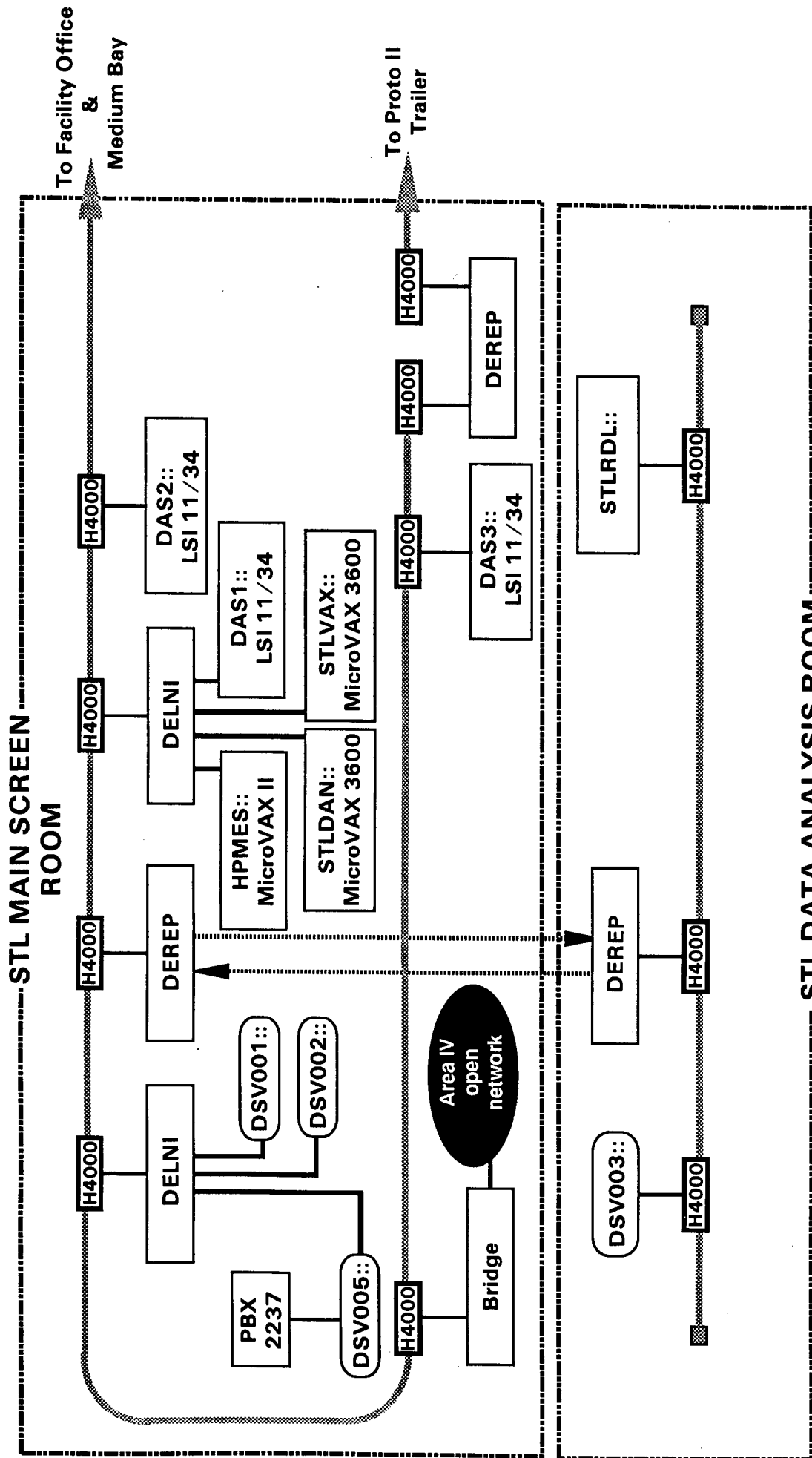

Fig. 20 - VAX System Layout

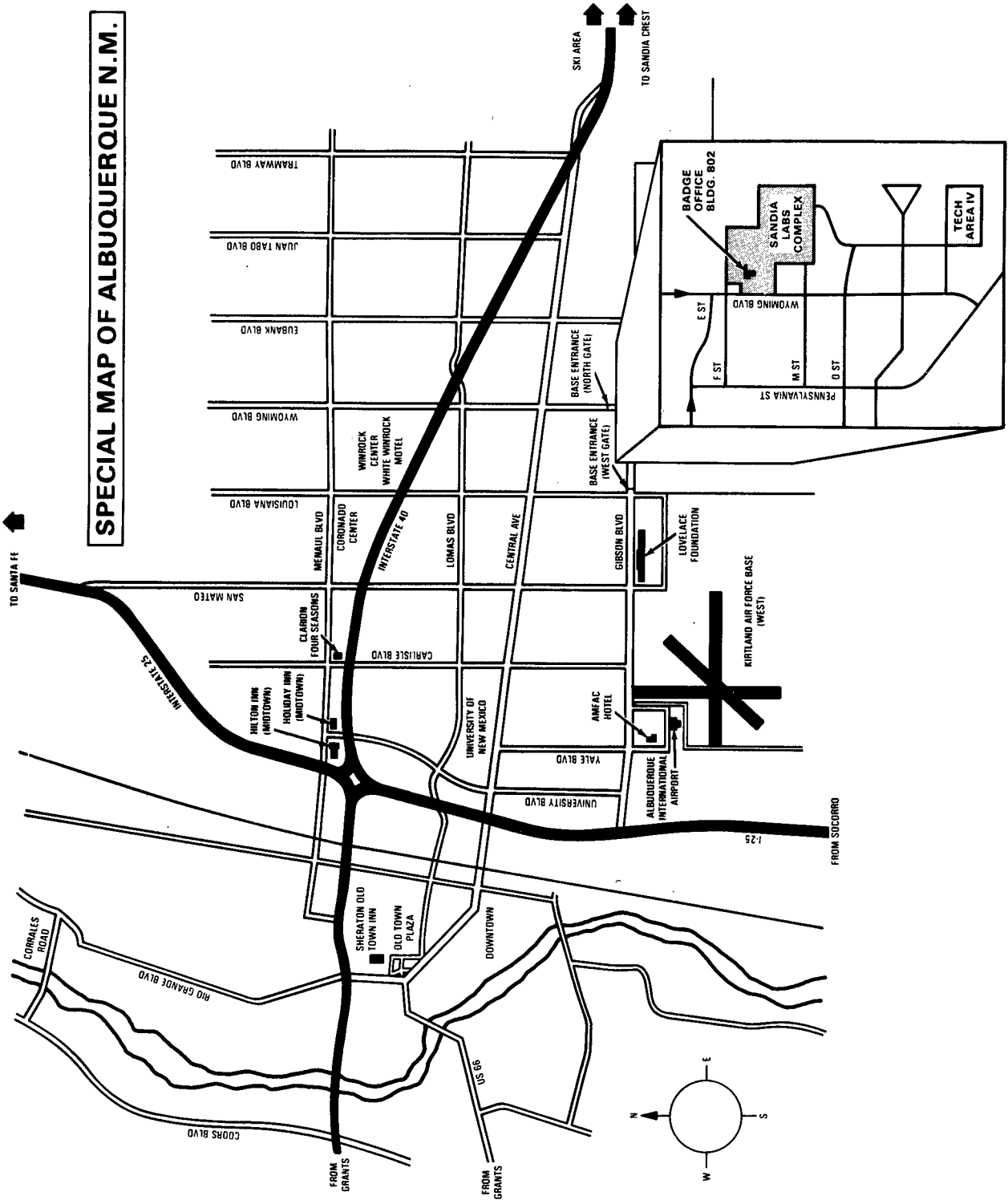

Fig. 21 - Location of Tech Area IV on Kirtland Air Force Base

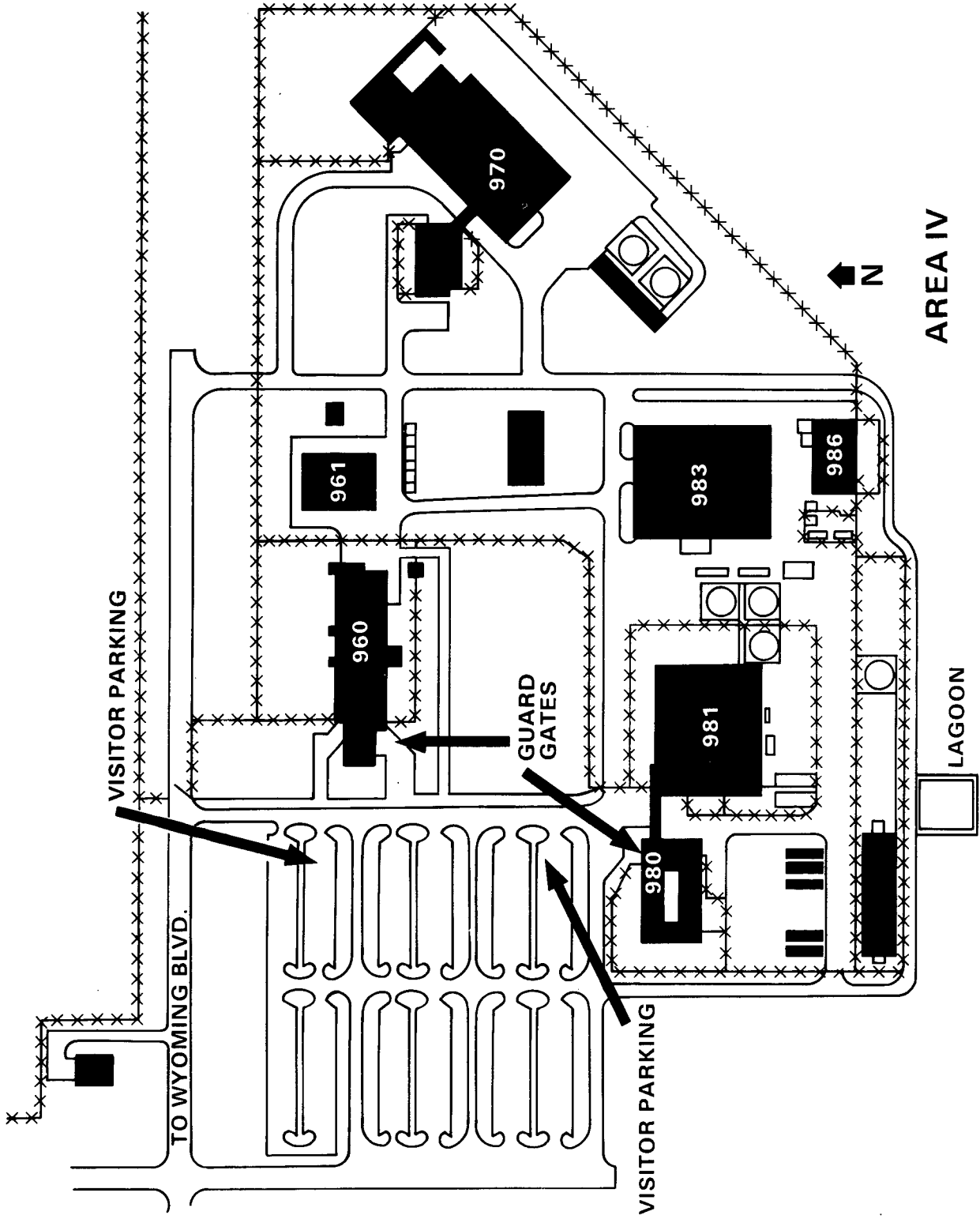

Fig. 22 - Tech Area IV, Showing Location of Building 970, STL

Distribution:

S. E. Downie
KTech
901 Pennsylvania Avenue NE
Albuquerque, NM 87110

D. Keller
KTech
901 Pennsylvania Avenue NE
Albuquerque, NM 87110

L. Lee
KTech
901 Pennsylvania Avenue NE
Albuquerque, NM 87110

9342 M. A. Hardemann
9342 T. F. Wrobel
9342-1 A. W. Sharpe
9343 G. A. Zawadzkas (50)
9343 G. S. Gustwiller (3)
9343 P. Micono
9343 K. A. Mikkelson
9343 R. W. Westfall
9350 J. H. Renken

1200 J. P. VanDevender
1231 J. R. Lee
1231 V. Harper-Slaboszewicz
1231 T. W. L. Sanford
1234 R. J. Leeper
1235 J. M. Hoffman
1237 G. W. Kuswa
1240 K. R. Prestwich
1243 B. N. Turman
1243-1 J. D. Boyes
1245 J. J. Ramirez
1248 M. T. Buttram
1264 R. W. Stinnett
1266 D. D. Bloomquist
1270 J. K. Rice
1272 D. H. McDaniel
1273 M. K. Matzen
1273 S. F. Lopez
1273 R. B. Spielman
2853 J. Smith
3141 S. Landenberger (5)
3141-1 C. L. Ward (8)
for DOE OSTI
3151 W. I. Klein (3)
6520 D. L. Berry (10)
6525 B. L. Spletzer (10)
6525 W. T. Wheelis
7823 L. O. Seamons
8524 J. A. Wackerly
9300 J. E. Powell
9310 J. D. Plimpton
9320 M. J. Navratil
9330 J. D. Kennedy
9341 W. Beezhold
9341 W. P. Ballard
9341 D. E. Beutler
9342 L. M. Choate (20)
9350 J. H. Renken