

M-05-89-001216-00-00-001

IDA PAPER P-2028

SAGEN USER'S GUIDE
Version 1.5

Michael R. Kappel
Cy D. Ardoin
Cathy Jo Linn
Joseph L. Linn
John Salasin

19980819 149
671 6188661

PLEASE RETURN TO:

BMD TECHNICAL INFORMATION CENTER
BALLISTIC MISSILE DEFENSE ORGANIZATION
7100 DEFENSE PENTAGON
WASHINGTON D.C. 20301-7100

Prepared for
Strategic Defense Initiative Organization (SDIO)



INSTITUTE FOR DEFENSE ANALYSES
1801 N. Beauregard Street, Alexandria, Virginia 22311

DEFINITIONS

IDA publishes the following documents to report the results of its work.

Reports

Reports are the most authoritative and most carefully considered products IDA publishes. They normally embody results of major projects which (a) have a direct bearing on decisions affecting major programs, or (b) address issues of significant concern to the Executive Branch, the Congress and/or the public, or (c) address issues that have significant economic implications. IDA Reports are reviewed by outside panels of experts to ensure their high quality and relevance to the problems studied, and they are released by the President of IDA.

Papers

Papers normally address relatively restricted technical or policy issues. They communicate the results of special analyses, interim reports or phases of a task, ad hoc or quick reaction work. Papers are reviewed to ensure that they meet standards similar to those expected of refereed papers in professional journals.

Memorandum Reports

IDA Memorandum Reports are used for the convenience of the sponsors or the analysts to record substantive work done in quick reaction studies and major interactive technical support activities; to make available preliminary and tentative results of analyses or of working group and panel activities; to forward information that is essentially unanalyzed and unevaluated; or to make a record of conferences, meetings, or briefings, or of data developed in the course of an investigation. Review of Memorandum Reports is suited to their content and intended use.

The results of IDA work are also conveyed by briefings and informal memoranda to sponsors and others designated by the sponsors, when appropriate.

The work reported in this document was conducted under contract MDA 903 84 C 0031 for the Department of Defense. The publication of this IDA document does not indicate endorsement by the Department of Defense, nor should the contents be construed as reflecting the official position of that agency.

This paper has been reviewed by IDA to assure that it meets high standards of thoroughness, objectivity, and sound analytical methodology and that the conclusions stem from the methodology.

Approved for public release; distribution unlimited

REPORT DOCUMENTATION PAGE

1a REPORT SECURITY CLASSIFICATION Unclassified			1b RESTRICTIVE MARKINGS		
2a SECURITY CLASSIFICATION AUTHORITY			3 DISTRIBUTION/AVAILABILITY OF REPORT Approved for public release: distribution unlimited.		
2b DECLASSIFICATION/DOWNGRADING SCHEDULE			5 MONITORING ORGANIZATION REPORT NUMBER(S)		
4 PERFORMING ORGANIZATION REPORT NUMBER(S) IDA Paper P-2028			7a NAME OF MONITORING ORGANIZATION OUSDA, DIMO		
6a NAME OF PERFORMING ORGANIZATION Institute for Defense Analyses		6b OFFICE SYMBOL IDA	7b ADDRESS (City, State, and Zip Code) 1801 N. Beauregard St. Alexandria, VA 22311		
6c ADDRESS (City, State, and Zip Code) 1801 N. Beauregard St. Alexandria, VA 22311			9 PROCUREMENT INSTRUMENT IDENTIFICATION NUMBER MDA 903 84 C 0031		
8a NAME OF FUNDING/SPONSORING ORGANIZATION Strategic Defense Initiative Org.		8b OFFICE SYMBOL (if applicable) SDIO	10 SOURCE OF FUNDING NUMBERS		
8c ADDRESS (City, State, and Zip Code) SDIO/PI Room 1E149 Pentagon, Washington D.C. 20301-7100			PROGRAM ELEMENT NO.	PROJECT NO.	TASK NO. T-R5-422
11 TITLE (Include Security Classification) SAGEN USER'S GUIDE Version 1.5 (UNCLASSIFIED)			WORK UNIT ACCESSION NO.		
12 PERSONAL AUTHOR(S) Michael R. Kappel, Cy D. Ardoin, Cathy Jo Linn, Joseph L. Linn, John Salasin					
13a TYPE OF REPORT Final	13b TIME COVERED FROM _____ TO _____		14 DATE OF REPORT (Year, Month, Day) 1988 April		15 PAGE COUNT 53
16 SUPPLEMENTARY NOTATION					
17 COSATI CODES			18 SUBJECT TERMS (Continue on reverse if necessary and identify by block number)		
FIELD	GROUP	SUB-GROUP	System Architecture; Dataflow Modeling; Simulation; Ada; Battle Management (BM); Command, Control and Communications.		
19 ABSTRACT (Continue on reverse if necessary and identify by block number)					
IDA Paper P-2028 documents a tool that can facilitate the description of processes for the Strategic Defense System (SDS) and Battle Management/Command, Control and Communications (BM/C3) architectures. The process descriptions generated by this tool conform to the Strategic Defense Initiative (SDI) Architecture Dataflow Modeling Technique (SADMT)					
20 DISTRIBUTION/AVAILABILITY OF ABSTRACT <input checked="" type="checkbox"/> UNCLASSIFIED/UNLIMITED <input type="checkbox"/> SAME AS RPT. <input type="checkbox"/> DTIC USERS			21 ABSTRACT SECURITY CLASSIFICATION Unclassified		
22a NAME OF RESPONSIBLE INDIVIDUAL Dr. Cathy Jo Linn, IDA			22b TELEPHONE (Include area code) (703) 824-5520	22c OFFICE SYMBOL IDA/CSFD	

UNCLASSIFIED

IDA PAPER P-2028

SAGEN USER'S GUIDE
Version 1.5

Michael R. Kappel
Cy D. Ardoin
Cathy Jo Linn
Joseph L. Linn
John Salasin

April 1988



INSTITUTE FOR DEFENSE ANALYSES

Contract MDA 903 84 C 0031
Task T-R5-422

UNCLASSIFIED

CONTENTS

1. INTRODUCTION	2
2. PROCESS MODEL	2
3. CONVENTIONS	4
3.1 Notational Conventions	4
3.2 Syntactic Conventions	6
3.3 Semantic Conventions	6
3.4 Programmatic Conventions	6
3.5 Keyword Order	7
4. SYNTAX	7
4.1 Process Hierarchy, Ports and Data Types	7
4.2 Port Linkages	7
4.3 Process Semantics	8
5. SEMANTICS	8
5.1 Process Hierarchy, Ports and Data Types	8
5.2 Port Linkages	10
5.3 Process Semantics	10
6. EXECUTION	11
7. REFERENCES	12
APPENDIX A - SAGEN EXAMPLE	14
APPENDIX B - GENERATED SADMT	20
APPENDIX C - SIMULATION OUTPUT	32

LIST OF FIGURES

Figure 1. Depiction of a BM/C3 Process	3
Figure 2. Exploded View of BM/C3	4
Figure 3. Platforms, Technology Modules and Processes	5
Figure 4. Top Level Platform	14
Figure 5. Exploded View of Parent Process	15

1. INTRODUCTION

This paper documents the use of a tool that can facilitate the description of processes for Strategic Defense System (SDS) and Battle Management/Command, Control and Communications (BM/C3) architectures. The generated process description conforms to the Strategic Defense Initiative (SDI) Architecture Dataflow Modeling Technique (SADMT). SADMT descriptions use a complex Ada template to simulate SDS and BM/C3 architectures. This tool, called SAGEN (for SADMT Generator), accepts a simpler specification of the architecture and automatically generates the required SADMT template.

SAGEN eliminates much of the drudgery of specifying the SADMT template for each module. However, Ada must still be used to specify port linkages and process semantics. SADMT modules generated by SAGEN may then be compiled by an Ada compiler, linked with the SADMT Simulation Framework [Linn 88] which is also written in Ada, and executed to simulate the performance of the system.

The SAGEN specification provides constructs to support the SADMT process model. A system is modeled as a hierarchy of processes which communicate via ports. Familiarity with this abstract model as described in [Linn 88] is assumed, but familiarity with the syntax and implementation details of SADMT is not required.

This paper is organized as follows:

Section 2	SADMT process model
Section 3	notational, syntactic, and semantic conventions
Section 4	SAGEN syntax
Section 5	SAGEN semantics
Section 6	execution of SAGEN
Section 7	references
Appendix A	SAGEN example
Appendix B	generated SADMT code
Appendix C	Simulation output

2. PROCESS MODEL

To capture SDS and BM/C3 architectural specifications in early design stages, SADMT defines an abstract entity called a "process" and a mechanism for specifying a process as a set of communicating subprocesses. SADMT processes are defined in a specific format and interprocess communications are performed according to a specific model. SADMT architectural descriptions use the standard syntax and semantics of Ada to capture the information needed to simulate the system.

In SADMT, a system is viewed as a hierarchy of processes. The system itself is the zero-th level process and is specified as a network of level-one processes; similarly, a level-n process may be specified as an interconnected set of level-(n+1) processes. Eventually, some processes will be leaf nodes since they are not decomposed further. The leaf processes contain the semantics of

the system. Leaf processes need not all be at the same level.

SADMT processes are defined to have "ports", i.e., windows for passing data into or out of a process. All interprocess communication is accomplished via these ports. A port is either an input port or an output port; SADMT makes no provision for bi-directional ports. Furthermore, ports in SADMT are typed to restrict the data which may flow into or out of a port.

SADMT provides a facility to specify the interconnections of communicating processes. There are three types of interprocess communications links: (1) internal, (2) input-inherited, and (3) output-inherited. In all cases, the data type of the connected ports must be the same. The first type of link, internal, connects an output port of a subprocess to an input port of another subprocess of the same parent process. Inherited links capture the concept that data flowing through a port on a higher level process is actually the input or output of lower level processes. An input-inherited link connects an input port on a parent process to an input port one of its child subprocesses. An output-inherited link connects an output port on a child subprocess to an output port on its parent process.

Various types of links are depicted in Figure 1. The highest level of a BM/C3 process is shown with a single input port and a single output port. (Note that port names and types are not indicated.) Figure 2 is an exploded view of the BM/C3 process, seen as an interconnected set of three subprocesses: (1) threat assessment, (2) weapon assignment, and (3) view of world (a process to manage retained state data.) The solid lines represent internal links, while the dashed lines represent inherited links.

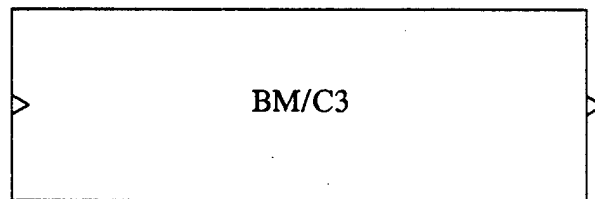

Figure 1. Depiction of a BM/C3 Process

SADMT processes are simulated within the SADMT Simulation Framework [Linn 88]. The Simulation Framework simulates the physical environment in which the SDS operates. The Simulation Framework employs two primitives - platforms and cones. Platforms represent all physical entities including the sensors, weapons, and carrier vehicles of the SDS and the weapons and debris of the threat. Cones represent entities such as communication waves and laser beams.

Platforms are composed of logical processes and technology modules (see Figure 3). Technology modules represent hardware technology such as sensors, weapons, communications and boosters. Technology modules provide the interface between SADMT processes and the Simulation Framework.

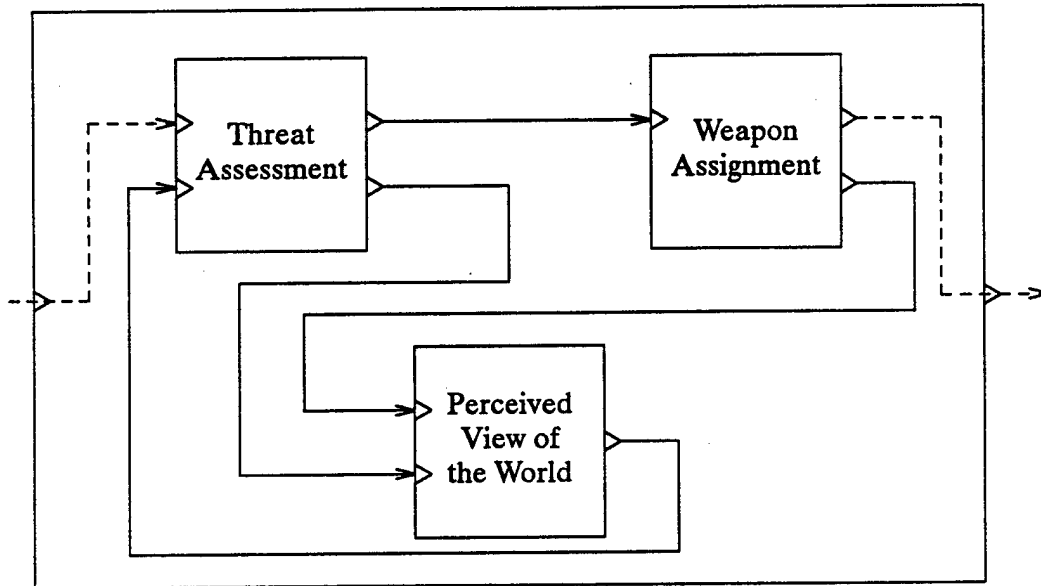

Figure 2. Exploded View of BM/C3

3. CONVENTIONS

3.1 Notational Conventions

The following notational conventions are used in the syntactic specification of SAGEN:

- <item> a variable item
- [item] an optional item
- {item1 | item2} item1 or item2
- {items}* items repeated zero or more times

The variables in the syntactic specification are defined as follows:

- <alias> a string of characters
- <data_type> a valid Ada data type
- <declarations> valid Ada declarations
- <default> a valid Ada expression
- <discriminant> a valid Ada discriminant
- <name> a valid Ada identifier
- <param_list> a list of parameters separated by commas

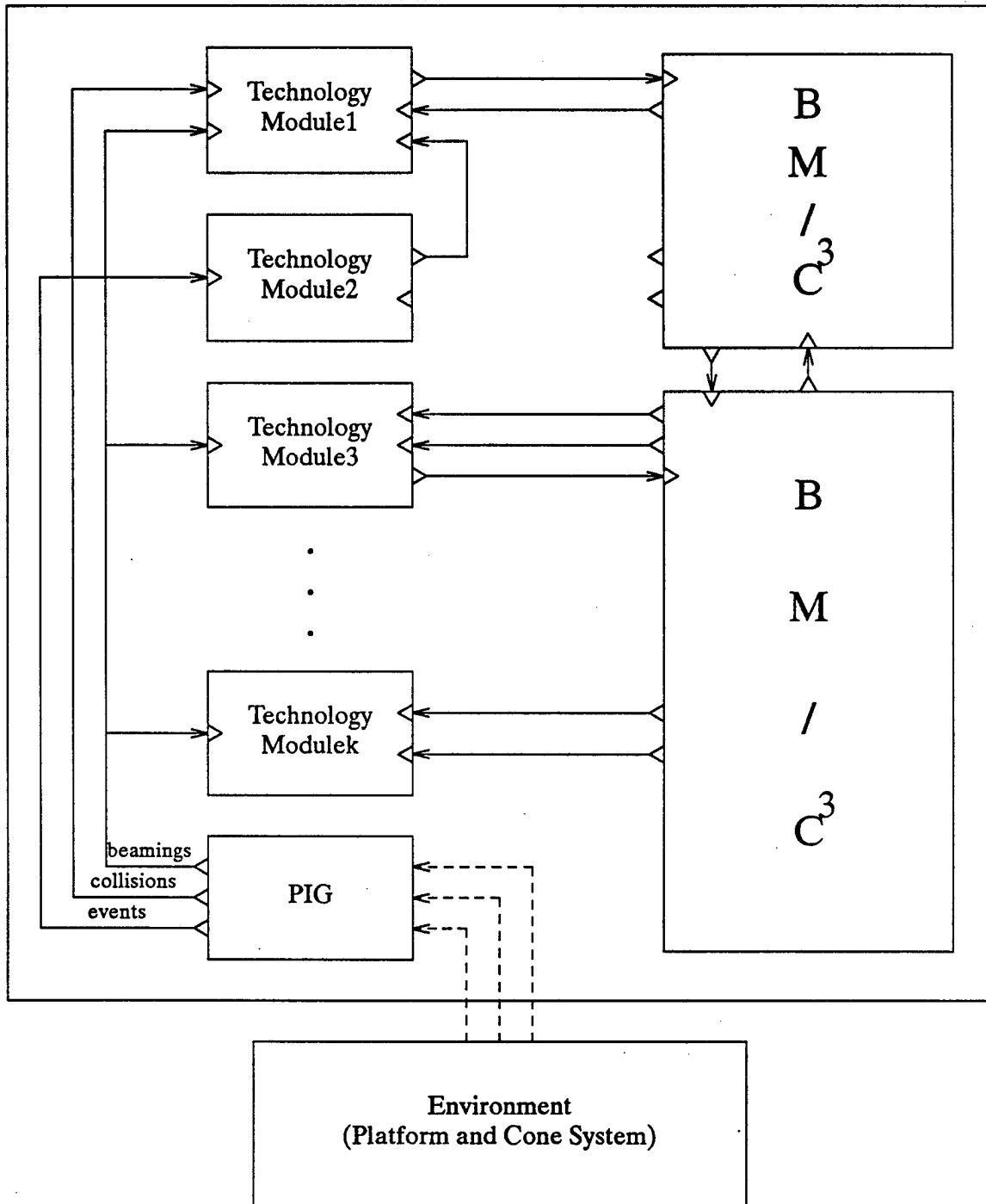

Figure 3. Platforms, Technology Modules and Processes

- | | |
|---------------|--|
| <range> | a valid Ada integer range |
| <with_or_use> | a set of valid Ada context and/or visibility clauses |

3.2 Syntactic Conventions

SAGEN syntactic conventions are Ada-like and non-restrictive:

1. A SAGEN statement may extend over more than one physical line.
2. More than one SAGEN statement may appear on one physical line.
3. SAGEN keywords and variables may appear in any column.
4. Ada comments may be embedded within a SAGEN statement.

3.3 Semantic Conventions

SAGEN semantic conventions are as follows:

1. Non-SAGEN code (i.e. Ada source and comments) should be valid Ada. If the code is not legal Ada, SAGEN will function properly, but the generated SADMT code will not compile.
2. The Ada source code appearing within SAGEN blocks should not violate the SADMT process model. The user-supplied Ada code should not include direct calls of other process tasks nor the abort statement.
3. The data type of a port is assumed to be declared in a user-supplied package having the same name as the data type followed by “_pkg”. For example, the package Order_pkg will be made visible to the process that has a port of type Order.
4. A temporary file called temporary.sagen is created and deleted by SAGEN. This file may appear if SAGEN terminates abnormally.
5. Comments placed within the main SAGEN block will appear before the package specification in the generated SADMT code. Comments placed within Ada source code in any SAGEN block will appear in the generated SADMT code as entered.
6. Any non-SAGEN code placed between SAGEN blocks will appear at the top of the next generated SADMT file.

3.4 Programmatic Conventions

1. The maximum number of subprocesses per parent process is set at 1000. This limit can be raised by changing constant *max_array_bound* in the SAGEN source file.
2. Variable names are limited to 80 characters. This limit can be raised by changing constant *max_line_length* in the SAGEN source file.
3. The generated SADMT files will be 80 characters wide. This convention can be altered by changing constant *max_line_length* in the SAGEN source file.
4. One physical input line is limited to 256 characters. This limit can be raised by changing variable *line* in the SAGEN source file.

3.5 Keyword Order

Process, platform or technology module must appear as the first SAGEN statement of each specification. Subprocess, inport, output, parameters, subdata and cone may follow in any order.

Process, platform or technology module and end must appear once for each specification. Subprocess, inport, output, parameters, subdata and cone may each appear zero or more times.

One link or one task block should then follow the main specification. A link block should appear for a platform or a non-leaf process or technology module. A task block should appear for a leaf process or technology module.

4. SYNTAX

SDS and BM/C3 architectures are described in three parts:

1. Process hierarchy, ports and data types
2. Port linkages
3. Process semantics

4.1 Process Hierarchy, Ports and Data Types

The syntax of SAGEN statements for specifying process hierarchy, ports and data types is:

```
[<with_or_use>]
{ $process <name> | $platform <name> := <alias> |
  $tech[nology]_module <name> |
  $dynamic_tech[nology]_module <name> := <alias> } is
  $subprocess[es] <name> [( <range> )] [ := ( <param_list> ) ]
    { , <name> [( <range> )] [ := ( <param_list> ) ] } * ;
  $[selectable_] [ { data_ | control_ | mech_ } ] { inport[s] | output[s] }
    <name> [( <range> ) ] : <data_type> [ := ( <param_list> ) ]
    { , <name> [( <range> ) ] : <data_type> [ := ( <param_list> ) ] } * ;
  $ { cone | event | platform } _inport [ <name> ] ;
  $parameter[s] <name> : <data_type> [( <discriminant> ) ] := ( <default> )
    { , <name> : <data_type> [( <discriminant> ) ] := ( <default> ) } * ;
  $subdata <data_type> { , <data_type> } * ;
  $cone[s] <data_type> { , <data_type> } * ;
$begin
  [Ada source lines (body)]
$end;
```

4.2 Port Linkages

The syntax of SAGEN statements for specifying port linkages is:

```
[<with_or_use>]
$link[s] <name> is
```

```

    [<declarations>]
    $begin
    [Ada source lines (link)]
    $end;

```

4.3 Process Semantics

The syntax of SAGEN statements for specifying process semantics is:

```

    [<with_or_use>]
    $task <name> is
    [<declarations>]
    $begin
    [Ada source lines (task)]
    $end;

```

5. SEMANTICS

5.1 Process Hierarchy, Ports and Data Types

The semantics of each SAGEN statement for specifying process hierarchy, ports and data types are described below.

```

    [<with_or_use>]

```

These Ada context clauses (with) or visibility clauses (use) are placed at the head of the procedure specification.

```

    { $process <name> | $platform <name> := <alias> |
      $tech[nology]_module <name> |
      $dynamic_tech[nology]_module <name> := <alias> } is

```

Process, platform or technology module specifies the name of an SDI process, platform or technology module, respectively. In addition, a designator string name must be specified for a platform or a dynamic technology module. A dynamic technology module is a special module to facilitate the specification of companion modules such as sensor returns (see [Linn 88]). The specification and body of the creator task (which is what makes a platform process different from a regular SADMT process) is automatically inserted into the task body of the named platform.

```

    $subprocess[es] <name> [( <range> )] [ := ( <param_list> ) ]
    { , <name> [( <range> )] [ := ( <param_list> ) ] } * ;

```

Subprocess specifies the names of the SDI subprocesses associated with the named process, platform or technology module. The range parameter is used to specify an array of subprocesses. The param_list parameter may be used to specify parameters for initializing the subprocess (see [Linn 88]). These parameters will be included in the call to procedure initialize for the subprocess. If the named process, platform or technology module has no subprocesses (i.e. it is a leaf), the subprocess statement must not appear.

```

${selectable_} [{ data_ | control_ | mech_ } ] { inport[s] | outport[s] }
  <name> [( <range> ) ] : <data_type> [ := ( <param_list> ) ]
  { , <name> [( <range> ) ] : <data_type> [ := ( <param_list> ) ] } * ;

```

Inport specifies the names of ports that input data to the named process or technology module and the type of data flowing into each port. Outport specifies the names of ports that output data from the named process or technology module and the type of data flowing out of each port. (Platforms do not have ports. Dynamic technology modules have only special input ports (see below).) Ports may be further designated as selectable. A selectable port is one of a special subset of ports of the same type to which or from which data may be specifically directed (see [Linn 88]). Ports may also be designated as data, control or mechanism ports (a la the SDI System Design Language [SRS 87]). Such a designation is for documentation purposes only and does not influence the generated SADMT. The range parameter is used to specify an array of ports. The param_list parameter may be used to specify parameters for initializing the port (see [Linn 88]). These parameters will be included in the call to procedure initialize for the port.

```

${cone | event | platform}_inport [ <name> ] ;

```

Cone_inport, event_inport and platform_inport specify special input ports for dynamic technology modules. These are the only types of ports allowed for dynamic technology modules (see [Linn 88]). The name parameter specifies a name for the port. If a name is not provided, a default name will be supplied - "cone_in" for cone_inport, "event_in" for event_inport, and "platform_in" for platform_inport.

```

$parameter[s] <name> : <data_type> [( <discriminant> ) ] := ( <default> )
  { , <name> : <data_type> [( <discriminant> ) ] := ( <default> ) } * ;

```

Parameter specifies a set of parameters that are supplied to the initialize procedure in the named process, platform or technology module. Data type specifies the data type of the named parameter and default specifies its default value. A discriminant may be supplied for the data type.

```

$subdata <data_type> { , <data_type> } * ;

```

Subdata specifies the types of data that flow within and between the subprocesses of the named process, platform or technology module. These data types are made visible to the package specification of the named process, platform or technology module. A data type that is already specified for a port at this level need not be respecified as subdata for its subprocesses. If the named process, platform or technology module has no subprocesses, the subdata statement must not appear.

```

$cone[s] <data_type> { , <data_type> } * ;

```

Cone specifies data types for cones. Cones only make sense for leaf technology modules. A warning will be generated by SAGEN if cones are specified for processes or platforms or nonleaf technology modules. The cone data types are made visible to the package specification of the named technology module. Furthermore, procedure create_cone is renamed in the task body.

```

$begin

```

Begin specifies the beginning of a block of Ada source code.

[Ada source lines (body)]

These Ada source lines are procedures which are placed in the package body to be referenced by the initialize procedure or the task associated with the named process, platform or technology module.

\$end;

End specifies the end of the process, platform or technology module block.

5.2 Port Linkages

The semantics of each SAGEN statement for specifying port linkages is described below.

[<with_or_use>]

These Ada context clauses (with) or visibility clauses (use) are placed at the head of the initialize procedure.

\$link[s] <name> is

Link indicates the start of a block of Ada source lines that perform the necessary linkages among the subprocesses of the named process, platform or technology module. The name parameter must correspond to the name of the previous process, platform or technology module block. The link block must not be specified for a leaf process or technology module.

[<declarations>]

These Ada declarations are placed in the declarative region of the initialize procedure.

\$begin

Begin specifies the beginning of a block of Ada source code.

[Ada source lines (link)]

These Ada source lines specify the linkages among the subprocesses of the named process, platform or technology module.

\$end;

End specifies the end of the linkage block.

5.3 Process Semantics

The semantics of each SAGEN statement for specifying process semantics is described below.

[<with_or_use>]

UNCLASSIFIED

These Ada context clauses (with) or visibility clauses (use) are placed at the head of the task body.

`$task <name> is`

Task indicates the start of a block of Ada source lines that supply the semantics of the named process or technology module. The name parameter must correspond to the name of the previous process or technology module block. The task block must not be specified for a platform or a non-leaf process or technology module.

`[<declarations>]`

These Ada declarations are placed in the declarative region of the task body.

`$begin`

Begin specifies the beginning of a block of Ada source code.

`[Ada source lines (task)]`

These Ada source lines specify the semantics of the named process or technology module.

`$end;`

End specifies the end of the task block.

6. EXECUTION

SAGEN is invoked at the user's terminal by typing:

`sagen`

The following prompt will then appear on the screen:

Please enter the name of the SAGEN file

The user should then enter the name of the file containing the code to be translated.

If any lexical or syntactic errors are detected by SAGEN, an error message will appear on the screen. The message will indicate the type of error and display the line on which the error occurred.

After translation is complete, several new files are created that contain the generated SADMT code. The names of the new files will be:

<code><name>.a</code>	for package specifications
<code><name>_body.a</code>	for package bodies
<code><name>_link.a</code>	for port linkages
<code><name>_task.a</code>	for process semantics

UNCLASSIFIED

where <name> is the name of the associated process, platform, or technology module.

7. REFERENCES

- [Bell 71] Bell, C. Gordon and Allen Newell, *Computer Structures: Readings and Examples*, McGraw-Hill, 1971.
- [Cohen 88] Cohen, Howard, Steve H. Edwards, Cathy Jo Linn, Joseph L. Linn, and Cy D. Ardoin, *A Simple Example of an SADMT Architecture Specification*, Institute for Defense Analyses, 1988.
- [Linn 88] Linn, Joseph L., Cathy Jo Linn, Stephen H. Edwards, Michael R. Kappel, Cy D. Ardoin and John Salasin, *Strategic Defense Initiative Architecture Dataflow Modeling Technique*, Version 1.50, IDA Paper P-2035, Institute for Defense Analyses, March 1988.
- [SRS 87] *SDI-SDL Description Example for Version 1.2*, SRS Technologies, October 1987.

UNCLASSIFIED

UNCLASSIFIED

UNCLASSIFIED

APPENDIX A - SAGEN EXAMPLE

An example system specification in SAGEN is given in this Appendix, followed by the SADMT generated by the SAGEN processor in Appendix B, and the output generated by the Simulation Framework in Appendix C. An example of a simple SDI architecture specified in SAGEN, along with the automatically generated SADMT and the simulation output is given in [Cohen 88].

The example network of processes is shown in Figures 4 and 5.

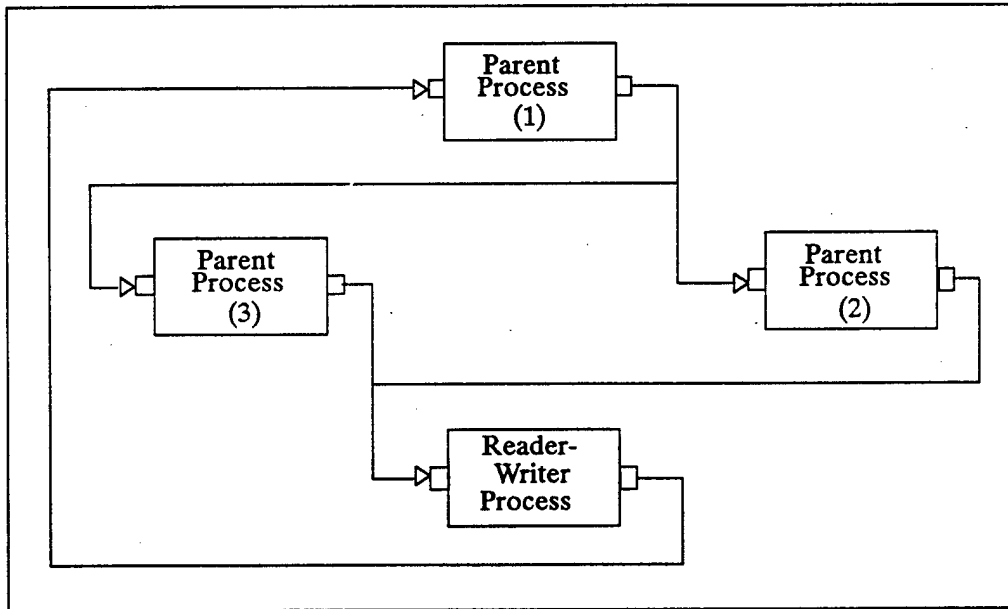

Figure 4. Top Level Platform

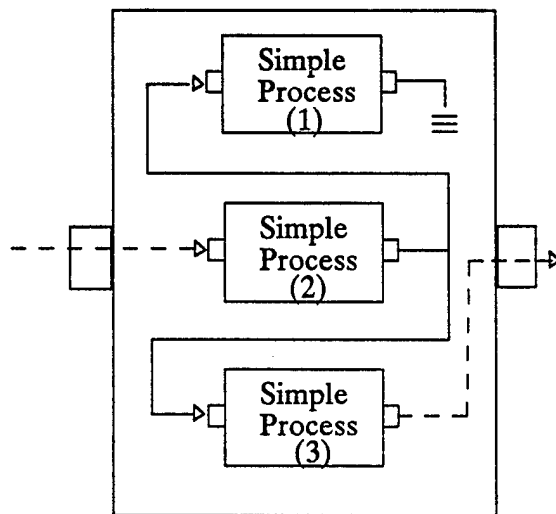

Figure 5. Exploded View of Parent Process

The following SAGEN represents the system of processes shown in these figures:

————— Top Level Platform —————

```

$platform TopLevel_Platform:=TOPLEVEL is
  $subprocesses Parent_Process(1..3), RW_Process;
  $subdata Simple_Msg;
$end;

$links TopLevel_Platform is
$begin
  internal_link (Z.SUB.Parent_Process(1).message_out,
                Z.SUB.Parent_Process(2).message_in);
  internal_link (Z.SUB.Parent_Process(1).message_out,
                Z.SUB.Parent_Process(3).message_in);
  internal_link (Z.SUB.Parent_Process(2).message_out,

```

UNCLASSIFIED

```
    Z.SUB.RW_Process.message_in);
internal_link (Z.SUB.Parent_Process(3).message_out,
    Z.SUB.RW_Process.message_in);
internal_link (Z.SUB.RW_Process.message_out,
    Z.SUB.Parent_Process(1).message_in);
$end;
```

Parent Process

```
$process Parent_Process is
  $subprocesses Simple_Process(1..3):=(wt(i));
  $inport message_in :Simple_Msg;
  $outport message_out:Simple_Msg;
$end;

$links Parent_Process is
  wt: constant array(1..3) of PDL_time_type := (20,30,50);
$begin
  internal_link (Z.SUB.Simple_Process(2).message_out,
    Z.SUB.Simple_Process(1).message_in);
  internal_link (Z.SUB.Simple_Process(2).message_out,
    Z.SUB.Simple_Process(3).message_in);
  inherited_link (Z.message_in,
    Z.SUB.Simple_Process(2).message_in);
  inherited_link (Z.SUB.Simple_Process(3).message_out,
    Z.message_out);
$end;
```

Simple Subprocess

```
$process Simple_Process is
  $inport message_in :Simple_Msg;
  $outport message_out:Simple_Msg;
  $parameter waittime:PDL_time_type:=(20);
$end;

$task Simple_Process is
  buffer: Simple_msg;
$begin
  loop
    wait_for_activity(Z.PDL);
    buffer:= port_data(Z.message_in);
    consume(Z.message_in);
    wait(Z.PDL,Z.PRM.waittime);
    buffer.last_slot:= buffer.last_slot + 1;
    buffer.route(buffer.last_slot):= integer(Z.PDL.process_id);
```

UNCLASSIFIED

UNCLASSIFIED

```
    emit(Z.message_out,buffer);
end loop;
exception
when others =>
    write_process_id(Z.PDL,"AND THEN SOME EXCEPTION in simple_proc, ");
Send;
```

RW Subprocess

```
$process RW_Process is
    $inport message_in :Simple_Msg;
    $outport message_out:Simple_Msg;
Send;
```

```
$task RW_Process is
    buffer          : Simple_Msg;
    start_up_time, last_time : PDL_time_type := 1000;
    which_port      : integer      := -50;
$begin
    start_up_time := Current_PDL_time;
    loop
        while not port_empty(Z.message_in) loop
            write_process_id(Z.PDL," DEQUEUEING-", "|", false);
            put_msg(port_data(Z.message_in),0);
            consume(Z.message_in);
        end loop;
        if last_time /= Current_PDL_time then
            if (Current_PDL_time - start_up_time) mod 40 = 0
                or (Current_PDL_time - start_up_time) mod 40 = 30 then
                buffer.time_created := Current_PDL_time;
                buffer.last_slot := 0;
                emit(Z.message_out,buffer);
                last_time := Current_PDL_time;
            end if;
        end if;
        wait_for_activity(Z.PDL,(Z.message_out.PORT
            ,Z.message_out.PORT
            ,Z.message_out.PORT
            ,Z.message_out.PORT
            ,Z.message_out.PORT
            ,Z.message_out.PORT
            ,Z.message_out.PORT
            ,Z.message_in.PORT)
            ,which_port
            ,Time_out => 10);
    end loop;
```

UNCLASSIFIED

UNCLASSIFIED

```
exception  
  when others =>  
    put_line("AND THEN SOME EXCEPTION in rw_proc");  
$end;
```

UNCLASSIFIED

UNCLASSIFIED

UNCLASSIFIED

UNCLASSIFIED

APPENDIX B - GENERATED SADMT

The following SADMT output files are created by the SAGEN tool:

***** TopLevel_Platform.a *****

Top Level Platform

```
with Cones_n_Platforms,Parent_Process_pkg,RW_Process_pkg,Simple_Msg_pkg;
package TopLevel_Platform_pkg is
  use Cones_n_Platforms;
  use PDL_pkg,Simple_Msg_pkg;
  TopLevel_Platform_designator : constant platform_designator_type
    := new string("TOPLEVEL");
  TopLevel_Platform_name       : PDL_string_ptr := new string'
    ("TopLevel_Platform");
  TopLevel_Platform_discr_name : PDL_string_ptr := empty_string;
  TopLevel_Platform_characteristic : PDL_string_ptr := new string'
    ("typename=TopLevel_Platform");
  type TopLevel_Platform_subprocesses is private;

  package TopLevel_Platform_PARAM_pkg is
    type TopLevel_Platform_parameterization is record
      null;
    end record;

    type TopLevel_Platform_parameterization_ptr is access
      TopLevel_Platform_parameterization;
  end TopLevel_Platform_PARAM_pkg;
  use TopLevel_Platform_PARAM_pkg;

  package TopLevel_Platform_CP_pkg is new interface_procs.PlatformDefiner_pkg
    (T=>TopLevel_Platform_parameterization,
     T_ptr=>TopLevel_Platform_parameterization_ptr);
private
  use PIG_pkg,Parent_Process_pkg,RW_Process_pkg;
  type Parent_Process_vector is array(integer range <>) of
    Parent_Process_type;
  type TopLevel_Platform_subprocesses is record
    PIG: PIG_type;
    Parent_Process: Parent_Process_vector(1..3);
    RW_Process: RW_Process_type;
  end record;
end TopLevel_Platform_pkg;
```

UNCLASSIFIED

UNCLASSIFIED

***** TopLevel_Platform_body.a *****

```
package body TopLevel_Platform_pkg is
  use Simple_Msg_pkg.PD.Procedures;
  use PDL_IO; use TXT_IO, INT_IO, TIME_IO, DURATION_IO;
  use interface_procs;

  type TopLevel_Platform_block;
  type TopLevel_Platform_type is access TopLevel_Platform_block;

  type TopLevel_Platform_block is record
    PDL: PDL_ptr := new_PDL_block(platform);
    SUB: TopLevel_Platform_subprocesses;
  end record;

  procedure initialize (ZZ: out PIG_type; param:
    TopLevel_Platform_parameterization_ptr; my_name: PDL_string_ptr :=
    TopLevel_Platform_name; discr_name: PDL_string_ptr :=
    TopLevel_Platform_discr_name; characteristic: PDL_string_ptr :=
    TopLevel_Platform_characteristic) is separate;

  package Creator is new PlatformCreator_pkg (
    TopLevel_Platform_parameterization,
    TopLevel_Platform_parameterization_ptr, lookup_platform_designator
    (TopLevel_Platform_designator), initialize);
end TopLevel_Platform_pkg;
```

***** TopLevel_Platform_link.a *****

```
separate (TopLevel_Platform_pkg)
procedure initialize (ZZ: out PIG_type; param:
  TopLevel_Platform_parameterization_ptr; my_name: PDL_string_ptr :=
  TopLevel_Platform_name; discr_name: PDL_string_ptr :=
  TopLevel_Platform_discr_name; characteristic: PDL_string_ptr :=
  TopLevel_Platform_characteristic) is
  Z: TopLevel_Platform_type;

begin
  Z := new TopLevel_Platform_block;
  declare
    PIG : PIG_type renames Z.SUB.PIG;
    Parent_Process : Parent_Process_vector renames Z.SUB.Parent_Process;
    RW_Process : RW_Process_type renames Z.SUB.RW_Process;
    MYSELF : PDL_ptr renames Z.PDL;
  begin
    set_process_parent(MYSELF, null, my_name, discr_name, characteristic);
    if init_debug_level > 100 then
```

UNCLASSIFIED

UNCLASSIFIED

```
write_process_full(MYSELF,"*init> ", " before start_up");
end if;
initialize(PIG,MYSELF);
for i in 1..3 loop
  initialize(Parent_Process(i),MYSELF
    ,discr_name => new string(integer'IMAGE(i)));
end loop;
initialize(RW_Process,MYSELF);
ZZ := PIG;

internal_link (Z.SUB.Parent_Process(1).message_out,
  Z.SUB.Parent_Process(2).message_in);
internal_link (Z.SUB.Parent_Process(1).message_out,
  Z.SUB.Parent_Process(3).message_in);
internal_link (Z.SUB.Parent_Process(2).message_out,
  Z.SUB.RW_Process.message_in);
internal_link (Z.SUB.Parent_Process(3).message_out,
  Z.SUB.RW_Process.message_in);
internal_link (Z.SUB.RW_Process.message_out,
  Z.SUB.Parent_Process(1).message_in);
end;

if init_debug_level > 100 then
  write_process_full(Z.PDL,"*init> ", " after start_up");
end if;
exception
  when others => write_process_full(Z.PDL,"***Some error in ", "***");
end initialize;

***** Parent_Process.a *****

-----
----- Parent Process -----
-----

with PDL_pkg, Simple_Msg_pkg, Simple_Process_pkg;
package Parent_Process_pkg is
  use PDL_pkg, Simple_Msg_pkg;

  type Parent_Process_block;
  type Parent_Process_type is access Parent_Process_block;

  type Parent_Process_subprocesses is private;

  type Parent_Process_block is record
    PDL: PDL_ptr := new_PDL_block(nonleaf);
```

UNCLASSIFIED

UNCLASSIFIED

```
SUB: Parent_Process_subprocesses;  
message_in: Simple_Msg_iptr := new Simple_Msg_port(inport);  
message_out: Simple_Msg_optr := new Simple_Msg_port(outport);  
end record;
```

```
Parent_Process_name      : PDL_string_ptr := new string'  
  ("Parent_Process");  
Parent_Process_type_name : PDL_string_ptr := new string'  
  ("Parent_Process");  
Parent_Process_discr_name : PDL_string_ptr := empty_string;  
Parent_Process_characteristic : PDL_string_ptr := new string'  
  ("typename=Parent_Process");
```

```
procedure initialize (Z: in out Parent_Process_type; Parent: PDL_ptr;  
  my_name: PDL_string_ptr := Parent_Process_name;  
  discr_name: PDL_string_ptr := Parent_Process_discr_name;  
  type_name: PDL_string_ptr := Parent_Process_type_name;  
  characteristic: PDL_string_ptr := Parent_Process_characteristic);
```

```
private  
  use Simple_Process_pkg;  
  type Simple_Process_vector is array(integer range <>) of  
    Simple_Process_type;  
  type Parent_Process_subprocesses is record  
    Simple_Process: Simple_Process_vector(1..3);  
  end record;  
end Parent_Process_pkg;
```

***** Parent_Process_body.a *****

```
package body Parent_Process_pkg is  
  use PDL_IO; use TXT_IO, INT_IO, TIME_IO, DURATION_IO;  
  use Simple_Msg_pkg.PD.Procedures;  
  procedure initialize (Z: in out Parent_Process_type; Parent: PDL_ptr;  
    my_name: PDL_string_ptr := Parent_Process_name;  
    discr_name: PDL_string_ptr := Parent_Process_discr_name;  
    type_name: PDL_string_ptr := Parent_Process_type_name;  
    characteristic: PDL_string_ptr := Parent_Process_characteristic  
  ) is separate;  
end Parent_Process_pkg;
```

***** Parent_Process_link.a *****

```
separate (Parent_Process_pkg)  
procedure initialize (Z: in out Parent_Process_type; Parent: PDL_ptr;  
  my_name: PDL_string_ptr := Parent_Process_name;  
  discr_name: PDL_string_ptr := Parent_Process_discr_name;
```

UNCLASSIFIED

```
type_name: PDL_string_ptr := Parent_Process_type_name;
characteristic: PDL_string_ptr := Parent_Process_characteristic) is

wt: constant array(1..3) of PDL_time_type := (20,30,50);
begin
  Z := new Parent_Process_block;
  declare
    message_in : Simple_Msg_iptr renames Z.message_in;
    message_out : Simple_Msg_optr renames Z.message_out;
    Simple_Process : Simple_Process_vector renames Z.SUB.Simple_Process;
    MYSELF : PDL_ptr renames Z.PDL;
  begin
    set_process_parent(MYSELF,Parent,my_name,discr_name,characteristic);
    if init_debug_level > 130 then
      write_process_full(MYSELF,"*init> ", " before start_up");
    end if;
    initialize(message_in,MYSELF,"portname=message_in","message_in");
    initialize(message_out,MYSELF,"portname=message_out","message_out");
    for i in 1..3 loop
      initialize(Simple_Process(i),MYSELF,wt(i)
        ,discr_name => new string'(integer'IMAGE(i)));
    end loop;

    internal_link (Z.SUB.Simple_Process(2).message_out,
      Z.SUB.Simple_Process(1).message_in);
    internal_link (Z.SUB.Simple_Process(2).message_out,
      Z.SUB.Simple_Process(3).message_in);
    inherited_link (Z.message_in,
      Z.SUB.Simple_Process(2).message_in);
    inherited_link (Z.SUB.Simple_Process(3).message_out,
      Z.message_out);

    end;
    make_known(Z.PDL);

    if init_debug_level > 130 then
      write_process_full(Z.PDL,"*init> ", " after start_up");
    end if;
    exception
      when others => write_process_full(Z.PDL,"***Some error in ","***");
    end initialize;

***** Simple_Process.a *****
```

Simple Subprocess

UNCLASSIFIED

UNCLASSIFIED

```
with PDL_pkg, Simple_Msg_pkg;
package Simple_Process_pkg is
  use PDL_pkg, Simple_Msg_pkg;

  package Simple_Process_PARAM_pkg is
    type Simple_Process_parameterization is record
      waittime: PDL_time_type := 20;
    end record;
  end Simple_Process_PARAM_pkg;
  use Simple_Process_PARAM_pkg;

  type Simple_Process_block;
  type Simple_Process_type is access Simple_Process_block;

  task type Simple_Process_task is
    entry start_up(Z: Simple_Process_type);
  end Simple_Process_task;
  type Simple_Process_task_ptr is access Simple_Process_task;

  type Simple_Process_block is record
    PDL: PDL_ptr := new_PDL_block(leaf);
    SEM: Simple_Process_task_ptr;
    PRM: Simple_Process_parameterization;
    message_in: Simple_Msg_ipptr := new Simple_Msg_port(inport);
    message_out: Simple_Msg_opptr := new Simple_Msg_port(outport);
  end record;

  Simple_Process_name      : PDL_string_ptr := new string'
    ("Simple_Process");
  Simple_Process_type_name : PDL_string_ptr := new string'
    ("Simple_Process");
  Simple_Process_discr_name : PDL_string_ptr := empty_string;
  Simple_Process_characteristic : PDL_string_ptr := new string'
    ("typename=Simple_Process");

  procedure initialize (Z: in out Simple_Process_type; Parent: PDL_ptr;
    waittime_param : PDL_time_type := 20; my_name: PDL_string_ptr :=
    Simple_Process_name; discr_name: PDL_string_ptr :=
    Simple_Process_discr_name; type_name: PDL_string_ptr :=
    Simple_Process_type_name; characteristic: PDL_string_ptr :=
    Simple_Process_characteristic);
end Simple_Process_pkg;
```

***** Simple_Process_body.a *****

```
package body Simple_Process_pkg is
  use PDL_IO; use TXT_IO, INT_IO, TIME_IO, DURATION_IO;
```

UNCLASSIFIED

UNCLASSIFIED

```
use Simple_Msg_pkg.PD.Procedures;
task body Simple_Process_task is separate;
procedure initialize (Z: in out Simple_Process_type; Parent: PDL_ptr;
  waittime_param : PDL_time_type := 20; my_name: PDL_string_ptr :=
  Simple_Process_name; discr_name: PDL_string_ptr :=
  Simple_Process_discr_name; type_name: PDL_string_ptr :=
  Simple_Process_type_name; characteristic: PDL_string_ptr :=
  Simple_Process_characteristic) is separate;
end Simple_Process_pkg;

***** Simple_Process_link.a *****
separate (Simple_Process_pkg)
procedure initialize (Z: in out Simple_Process_type; Parent: PDL_ptr;
  waittime_param : PDL_time_type := 20; my_name: PDL_string_ptr :=
  Simple_Process_name; discr_name: PDL_string_ptr :=
  Simple_Process_discr_name; type_name: PDL_string_ptr :=
  Simple_Process_type_name; characteristic: PDL_string_ptr :=
  Simple_Process_characteristic) is
begin
  Z := new Simple_Process_block;
  declare
    message_in : Simple_Msg_ipptr renames Z.message_in;
    message_out : Simple_Msg_opptr renames Z.message_out;
    waittime : PDL_time_type renames Z.PRM.waittime;
    MYSELF : PDL_ptr renames Z.PDL;
  begin
    set_process_parent(MYSELF,Parent,my_name,discr_name,characteristic);
    if init_debug_level > 130 then
      write_process_full(MYSELF,"*init> ", " before start_up");
    end if;
    waittime := waittime_param;
    initialize(message_in,MYSELF,"portname=message_in","message_in");
    initialize(message_out,MYSELF,"portname=message_out","message_out");
  end;
  Z.SEM := new Simple_Process_task;
  Z.SEM.start_up(Z);

  if init_debug_level > 130 then
    write_process_full(Z.PDL,"*init> ", " after start_up");
  end if;
  exception
    when others => write_process_full(Z.PDL,"***Some error in ","***");
end initialize;

***** Simple_Process_task.a *****
```

UNCLASSIFIED

UNCLASSIFIED

```

separate (Simple_Process_pkg)
task body Simple_Process_task is
  use timing_ops;
  Z : Simple_Process_type := null;

  buffer: Simple_msg;
begin
  accept start_up(Z:Simple_Process_type) do
    Simple_Process_task.Z := Z;
    make_known(Z.PDL);
  end start_up;

  declare
    message_in : Simple_Msg_iptr renames Z.message_in;
    message_out : Simple_Msg_opptr renames Z.message_out;
    waittime : PDL_time_type renames Z.PRM.waittime;
    MYSELF : PDL_ptr renames Z.PDL;
    package WAITING_pkg is new Wait_pkg(MYSELF);
    use WAITING_pkg;
  begin
    wait_for_initialization;
  loop
    wait_for_activity(Z.PDL);
    buffer:= port_data(Z.message_in);
    consume(Z.message_in);
    wait(Z.PDL,Z.PRM.waittime);
    buffer.last_slot:= buffer.last_slot + 1;
    buffer.route(buffer.last_slot):= integer(Z.PDL.process_id);
    emit(Z.message_out,buffer);
  end loop;
exception
  when others =>
    write_process_id(Z.PDL,"AND THEN SOME EXCEPTION in simple_proc, ");
  end;
  write_process_full(Z.PDL,"***** Invalid SADMT Process");
  kill_process(Z.PDL);
end Simple_Process_task;

```

***** RW_Process.a *****

----- RW Subprocess -----

```

with PDL_pkg, Simple_Msg_pkg;
package RW_Process_pkg is

```

UNCLASSIFIED

```
use PDL_pkg, Simple_Msg_pkg;

type RW_Process_block;
type RW_Process_type is access RW_Process_block;

task type RW_Process_task is
  entry start_up(Z:RW_Process_type);
end RW_Process_task;
type RW_Process_task_ptr is access RW_Process_task;

type RW_Process_block is record
  PDL: PDL_ptr := new_PDL_block(leaf);
  SEM: RW_Process_task_ptr;
  message_in: Simple_Msg_ipptr := new Simple_Msg_port(inport);
  message_out: Simple_Msg_opptr := new Simple_Msg_port(outport);
end record;

RW_Process_name      : PDL_string_ptr := new string("RW_Process");
RW_Process_type_name : PDL_string_ptr := new string("RW_Process");
RW_Process_discr_name : PDL_string_ptr := empty_string;
RW_Process_characteristic : PDL_string_ptr := new string'
  ("typename=RW_Process");

procedure initialize (Z: in out RW_Process_type; Parent: PDL_ptr;
  my_name: PDL_string_ptr := RW_Process_name;
  discr_name: PDL_string_ptr := RW_Process_discr_name;
  type_name: PDL_string_ptr := RW_Process_type_name;
  characteristic: PDL_string_ptr := RW_Process_characteristic);
end RW_Process_pkg;

***** RW_Process_body.a *****
package body RW_Process_pkg is
  use PDL_IO; use TXT_IO, INT_IO, TIME_IO, DURATION_IO;
  use Simple_Msg_pkg.PD.Procedures;
  task body RW_Process_task is separate;
  procedure initialize (Z: in out RW_Process_type; Parent: PDL_ptr;
    my_name: PDL_string_ptr := RW_Process_name;
    discr_name: PDL_string_ptr := RW_Process_discr_name;
    type_name: PDL_string_ptr := RW_Process_type_name;
    characteristic: PDL_string_ptr := RW_Process_characteristic
  ) is separate;
end RW_Process_pkg;

***** RW_Process_link.a *****
separate (RW_Process_pkg)
procedure initialize (Z: in out RW_Process_type; Parent: PDL_ptr;
```

UNCLASSIFIED

UNCLASSIFIED

```
my_name: PDL_string_ptr := RW_Process_name; discr_name: PDL_string_ptr :=
RW_Process_discr_name; type_name: PDL_string_ptr := RW_Process_type_name;
characteristic: PDL_string_ptr := RW_Process_characteristic) is
begin
  Z := new RW_Process_block;
  declare
    message_in : Simple_Msg_iptr renames Z.message_in;
    message_out : Simple_Msg_opptr renames Z.message_out;
    MYSELF : PDL_ptr renames Z.PDL;
  begin
    set_process_parent(MYSELF,Parent,my_name,discr_name,characteristic);
    if init_debug_level > 130 then
      write_process_full(MYSELF,"*init> ", " before start_up");
    end if;
    initialize(message_in,MYSELF,"portname=message_in","message_in");
    initialize(message_out,MYSELF,"portname=message_out","message_out");
  end;
  Z.SEM := new RW_Process_task;
  Z.SEM.start_up(Z);

  if init_debug_level > 130 then
    write_process_full(Z.PDL,"*init> ", " after start_up");
  end if;
  exception
    when others => write_process_full(Z.PDL,"***Some error in ","***");
end initialize;

***** RW_Process_task.a *****

separate (RW_Process_pkg)
task body RW_Process_task is
  use timing_ops;
  Z : RW_Process_type := null;

  buffer      : Simple_Msg;
  start_up_time, last_time : PDL_time_type := 1000;
  which_port  : integer := -50;
begin
  accept start_up(Z:RW_Process_type) do
    RW_Process_task.Z := Z;
    make_known(Z.PDL);
  end start_up;

  declare
    message_in : Simple_Msg_iptr renames Z.message_in;
    message_out : Simple_Msg_opptr renames Z.message_out;
```

UNCLASSIFIED

UNCLASSIFIED

```
MYSELF : PDL_ptr renames Z.PDL;
package WAITING_pkg is new Wait_pkg(MYSELF);
use WAITING_pkg;
begin
  wait_for_initialization;
  start_up_time := Current_PDL_time;
  loop
    while not port_empty(Z.message_in) loop
      write_process_id(Z.PDL,"  DEQUEUEING-",",",false);
      put_msg(port_data(Z.message_in),0);
      consume(Z.message_in);
    end loop;
    if last_time /= Current_PDL_time then
      if (Current_PDL_time - start_up_time) mod 40 = 0
        or (Current_PDL_time - start_up_time) mod 40 = 30 then
        buffer.time_created := Current_PDL_time;
        buffer.last_slot := 0;
        emit(Z.message_out,buffer);
        last_time := Current_PDL_time;
      end if;
    end if;
    wait_for_activity(Z.PDL,(Z.message_out.PORT
      ,Z.message_out.PORT
      ,Z.message_out.PORT
      ,Z.message_out.PORT
      ,Z.message_out.PORT
      ,Z.message_out.PORT
      ,Z.message_in.PORT)
      ,which_port
      ,Time_out => 10);
  end loop;
exception
  when others =>
    put_line("AND THEN SOME EXCEPTION in rw_proc");
  end;
  write_process_full(Z.PDL,"***** Invalid SADMT Process");
  kill_process(Z.PDL);
end RW_Process_task;
```

UNCLASSIFIED

UNCLASSIFIED

UNCLASSIFIED

APPENDIX C - SIMULATION OUTPUT

The following is the output generated by running the SADMT description of the system of processes depicted in Figures 4 and 5 on the prototype SSF simulation facility:

hello

simulation begins.....

```

DEQUEUEING--RW_Process/[PL]PR=[1]10<t=160>|the message ts,r=0:2:3:5:6:
DEQUEUEING--RW_Process/[PL]PR=[1]10<t=160>|the message ts,r=0:2:3:8:9:
DEQUEUEING--RW_Process/[PL]PR=[2]21<t=185>|the message ts,r=25:13:14:16:17:
DEQUEUEING--RW_Process/[PL]PR=[2]21<t=185>|the message ts,r=25:13:14:19:20:
DEQUEUEING--RW_Process/[PL]PR=[1]10<t=230>|the message ts,r=30:2:3:5:6:
DEQUEUEING--RW_Process/[PL]PR=[1]10<t=230>|the message ts,r=30:2:3:8:9:
AND THEN SOME EXCEPTION in Simple_Process(1)/[PL]PR=[2]12|@|Parent_Process/[PL]PR=[2]-4|on|
AND THEN SOME EXCEPTION in Simple_Process(2)/[PL]PR=[2]13|@|Parent_Process/[PL]PR=[2]-4|on|
AND THEN SOME EXCEPTION in Simple_Process(3)/[PL]PR=[2]14|@|Parent_Process/[PL]PR=[2]-4|on|
AND THEN SOME EXCEPTION in Simple_Process(1)/[PL]PR=[2]15|@|Parent_Process/[PL]PR=[2]-5|on|
AND THEN SOME EXCEPTION in Simple_Process(2)/[PL]PR=[2]16|@|Parent_Process/[PL]PR=[2]-5|on|
AND THEN SOME EXCEPTION in Simple_Process(3)/[PL]PR=[2]17|@|Parent_Process/[PL]PR=[2]-5|on|
AND THEN SOME EXCEPTION in Simple_Process(1)/[PL]PR=[2]18|@|Parent_Process/[PL]PR=[2]-6|on|
AND THEN SOME EXCEPTION in Simple_Process(2)/[PL]PR=[2]19|@|Parent_Process/[PL]PR=[2]-6|on|
AND THEN SOME EXCEPTION in Simple_Process(3)/[PL]PR=[2]20|@|Parent_Process/[PL]PR=[2]-6|on|
AND THEN SOME EXCEPTION in RW_Process/[PL]PR=[2]21|@|TopLevel_Platform(2)/[PL]PR=[2]0<t=
AND THEN SOME EXCEPTION in gyro, Gyro_Process/[PL]PR=[2]22<t=260>
DEQUEUEING--RW_Process/[PL]PR=[1]10<t=310>|the message ts,r=40:2:3:5:6:
DEQUEUEING--RW_Process/[PL]PR=[1]10<t=310>|the message ts,r=40:2:3:8:9:
DEQUEUEING--RW_Process/[PL]PR=[1]10<t=390>|the message ts,r=70:2:3:5:6:
DEQUEUEING--RW_Process/[PL]PR=[1]10<t=390>|the message ts,r=70:2:3:8:9:
DEQUEUEING--RW_Process/[PL]PR=[1]10<t=470>|the message ts,r=80:2:3:5:6:
DEQUEUEING--RW_Process/[PL]PR=[1]10<t=470>|the message ts,r=80:2:3:8:9:

```

Jim Armitage
GTE SSD
1 Research Dr.
Westborough, MA 01581

David Audley, Associate
Financial Strategies
Prudential Bache Securities
26th Floor
199 Water
New York, NY 10292

Dr. Algirdas Avizienis
Computer Science Department
4731 Boelter Hall
University of California, Los Angeles
Los Angeles, CA 90024

Dan Baker
TASC
55 Walkers Brook Drive
Redding, MA 01867

Gary H. Barber
Program Manager
Intermetrics, Inc.
1100 Hercules, Suite 300
Houston, TX 77058

John Barry
SJ-72
Rockwell
P.O. Box 3644
Seal Beach, CA 90740-7644

Elizabeth Bently
Marketing Coordinator
Research Triangle Institute
P.O. Box 12184
Research Triangle Park, N.C. 27709

Cheryl Bittner
General Electric
Box 8555, Bldg. 19, Suite 200
Philadelphia, PA 19101

Grady Booch
Director, Software Engineering Program
Rational
1501 Salad~ Dr.
Mountain View, CA 94043

Gina Bowden
MS 202
Teledyne Brown Engineering
Cummings Research Park
Huntsville, AL 35807

James M. Boyle
Mathematics & Computer Science Division
Argonne National Laboratory
Argonne, IL 60549-4844

Craig Bredin
GTE Strategic Systems Division
3322 South Memorial Parkway
Suite 53
P.O. Box 14009
Huntsville, AL 35185

Capt. John R. Brill
USAF Space Division/ALR
DET 3 AFALC
Box 92960 WPC
Los Angeles, CA 90009

Alton L. Brintzenhoff
Manager, Ada Technology Operating Center
Syscon Corporation
3990 Sherman St.
San Diego, CA 92110

Dr. James C. Browne
Computation Center
Department of Computer Science
University of Texas at Austin
Austin, TX 78712

Dr. Robert R. Brown
Rand Corp.
1700 Main St.
P.O. Box 2138
Santa Monica, CA 90406

Miguel Carrio
Teledyne Brown Engineering
3700 Pender Dr.
Fairfax, VA 22030

Tom Cashion
CALSPAN Corporation
P.O. Box 9X
Lexington, MA 02123

Virginia Castor, Director
Ada Joint Program Office
1211 Fern St., Room C-107
Arlington, VA 22202

Yvonne Cekel
Marketing Services Manager
Cadre Technologies, Inc.
222 Richmond St.
Providence, RI 02903

Bijoy G. Chatterjee
Deputy Director
Advanced Technology Systems
ESL/TRW
495 Java Dr.
P.O. Box 3510
Sunnyvale, CA 3510

John L. Chinn
Manager, Advanced Technology program
General Electric Space Systems Division
4041 North First St.
San Jose, CA 95134

Starla Christakos
AFATL/SAI
Eglin Air Force Base, FL 320542

Dr. Joe Clema
ECAC/IITRI
185 Admiral Cochrane Drive
Annapolis, MD 21401

Karen Coates
Program Manager, Advanced Technology
ESL/TRW
495 Java Dr.
P.O. Box 3510
Sunnyvale, CA 94088-3510

Susan Coatney
Information Science Institute
University of Southern California
4676 Admiralty Way
Marina del Ray, CA 90292-5950

Mr. Danny Cohen
Director, System Division
Information Science Institute
University of Southern California
4676 Admiralty Way
Marina del Rey, CA 90292-6695

Christopher F. Cole
Marketing Representative
Technology Programs
General Electric Company
Space Systems Division
Valley Forge Space Center
P.O. Box 8555
Philadelphia, PA 19101

Carol Combs
National Security Agency
9800 Savage Road
Ft. Meade, MD 20755-6000

Edward R. Comer
Software Productivity Solutions, Inc.
122 North 4th Av.
Indialantic, FL 32903

Lawrence L. Cone
Cone Software Laboratory
312 East Summit Av.
Haddonfield, N.J. 08033

Robert P. Cook
Department of Computer Science
Thornton Hall
University of Virginia
Charlottesville, VA 22903

Chuck Cooper
Control Data Corporation
901 E. 78th Street
MS BMW 03M
Minneapolis, MN 55420

Lee Cooper
Advanced Technology
2121 Crystal Drive, Suite 200
Arlington, VA 22202

Mark Cosby
Science Applications International Corp.
1710 Goodridge Drive
McLean, VA 22012

L. Cristina
USASD
ATTN: DASD-H-SBY
P.O. 1500
106 Wynn Dr.
Huntsville, AL 35807-3801

Vincent Dambrauskas
Technical Director
Washington Technical Center
Strategic Systems Division
GTE Government Systems Corporation
6850 Versar Center, Suite 354
Springfield, VA 22151-4196

Samuel A. DeNitto
Romse Air Development Center
RADC/COE, Bldg. 3
Griffis AFB, NY 13441-5700

Cameron M.G. Donaldson
Software Productivity Solutions, Inc.
122 North 4th Av.
Indialantic, FL 32903

Ralph Duncan
Control Data Government Systems
300 Embassy Row
Atlanta, GA 30328

Stephen Edwards
1-55 Caltech
Pasadena, CA 91126

Jim Egolf
Ford Aerospace & Computer Corp.
10440 State Hwy. 83
Colorado Springs, CO 80908

David A. Fisher
Incremental Systems Corporation
319 S. Craig St.
Pittsburgh, PA 15213

Dave Fitz
STARS Program Office
OUS
OUSDRE (R&AT/CET)
3D139
1211 Fern St., C-112
Washington, D.C. 20301-3081

Michel A. Floyd
Integrated Systems Inc.
101 University Av.
Palo Alto, CA 94301-1695

Richard Frase
SRS Technologies
1500 Wilson Blvd., Suite 800
P.O. Box 12707
Arlington, VA 22209-8707

George Gearn
Applied Researsch & Engineering
7 Railroad Avenue, Suite F
Bedford, MA 01730

Victor Giddings
MITRE Corporation
Burlington Road
Bedford, MA 01730

Claren Giese
SDIO
Pentagon
T/KE
Washington, DC 20301-7100

Colin Gilyeat
Advanced Technology
2121 Crystal Drive
Arlington, VA 22202

Robert T. Goettge
Advanced Systems Technology
12200 East Briarwood Av.
Suite 260
Englewood, CO 80112

H.T. Goranson
Sirius Inc.
P.O. Box 9258
760 Lynnhaven Parkway
Virginia Beach, VA 23452

Barbara Guyette
Marketing Specialist
Ada Products Division
Intermetrics, Inc.
733 Concord Av.
Cambridge, MA 02138

Sarah Hadley
National Security Agency
9800 Savage Road
Fort Meade, MD 20755-6000

Shmuel Halevi
Ad Cad Inc.
University Place, Suite 200
124 Mt. Auburn St.
Cambridge, MA 02138

Robert Haley
Director, SDI Programs
Cray Research, Inc.
1331 Pennsylvania Avenue, N.W.
Suite 1331 North
Washington, DC 2004

Margaret Hamilton, President
Hamilton Technologies, Inc.
17 Inman St.
Cambridge, MA 02139

Duane Harder
MS B-218
Los Alamos National Laboratory
Los Alamos, NM 87545

Evans C. Harrigan
Software Consultant
Cray Research, Inc.
2130 Main Street., Suite 280
Huntington Beach, CA 92648

Hal Hart
TRW Defense Systems Group
One Space Park
Redondo Beach, CA 90278

Goran Hemdahl
Technical Director
Advanced Systems Architectures
Johnson House, 73-79 Park Street
Camberley, Surrey GU15 3PE United Kingdom

Dale B. Henderson
Los Alamos National Laboratory
Receiving Department
Bldg. SM-30
Bikini Road
Los Alamos, NM 87545

John W. Hendricks
Systems Technologies, Inc.
242 Ocean Drive West
Stamford, CT 06902

Stephan L. Hise
Advanced Development Programs
Marketing Department - MS 1112
Westinghouse Electric Corporation
Defense Group
Friendship Site
Box 1693
Baltimore, MD 21203

Jung Pyo Hong
Los Alamos National Lab
MS K488
P.O. Box 1633
Los Alamos, NM 87544

Don Horne
SRS Technologies
1500 Wilson Blvd., Suite 800
Arlington, VA 22209-8707

Bill Horton
MITRE Corp.
1259 Lake Plaza Drive
Colorado Springs, CO 80906

Greg Janee
General Research Corp.
5383 Hollister Avenue
Santa Barbara, CA 93111

Andy Jazwinski, Director
Advanced Development
TASC - The Analytic Sciences Corporation
1700 N. Moore St., Suite 1220
Arlington, VA 22209

James R. Jill
Manager, Advanced Technologies
NTB Design
Martin Marietta Information & Communications Systems
P.O. Box 1260
Denver, CO 80201-1260

Sumalee Johnson
Rockwell Institute
P.O. Box 3644
Seal Beach, CA 90704-7644

W.G. (Gray) Jones
Science Applications International Corporation
1710 Goodridge Drive
McLean, VA 22102

Irene G. Kazakova
Director, Marketing
Interactive Development Environments
150 Fourth Street, Suite 210
San Francisco, CA 94103

Peter Keenan
Science Ltd.
Wavendon Towe
Milton, Keynes
England MK17-8LX

Judy Kerner
TRW R2/1134
One Space Park
Redondo Beach, CA 90278

Rebecca Kidd
General Research Corp.
307 Wynn Drive
Huntsville, AL 35805

Virginia P. Kobler
Chief, Technology Branch
Battle Management Division
Department of the Army
Office of the Chief of Staff
U.S. Army Strategic Defense Command
P.O. Box 1500
Huntsville, AL 35807-3801

Dr. Ijur Kulikov
Intermetrics
607 Louis Drive
Warminster, PA 18974

Lt. Ann Kuo
ESD/ATS
Hanscom AFB, MA 07831

John Michael Lake
2311 Galen Dr. #7
Champaign, IL 61821

John Latimer
Teledyne Brown Engineering
300 Sparkman Dr.
MS 44
Huntsville, AL 35807

Steve Layton
Senior Software Engineer
Martin Marietta Denver Aerospace
MS L0425
P.O. Box 179
Denver, CO 80201

Larry L. Lehman
Integrated Systems Inc.
2500 Mission College Road
Santa Clara, CA 95054

Eric Leighninger
Dynamics Research
60 Frontage Road
Andover, MA 01810

Peter Lempp
Software Products and Services, Inc.
14 East 38th Street, 14th Floor
New York, NY 10016

Bob Liley
Rockwell International Corporation
2600 West Minister Blvd.
Seal Beach, CA 90740-7644

Frank Poslajko
U.S. Army SDC
CSSD-H-SI
Huntsville, AL 35807-3801

Brian Smith
Mathematics & Computer Science Div.
Argonne National Laboratory
Building 221, Room C-219
9700 South Cass Avenue
Argonne, IL 60439-4844

Norman G. Snyder
Director of Software Services
Jodgrey Associates, Inc.
462 Highfield Ct.
Severna Park, MD 21146

J.R. Southern
USA-SDC
DASD-H-SBD
106 Wynn Drive
Huntsville, AL 35807-3801

Henry Sowizral
Schlumberger Palo Alto Research
3340 Hillview Avenue
Palo Alto, CA 94304

Stephen L. Squires
DARPA
Information Processing Techniques Office
1400 Wilson Blvd.
Arlington, VA 22209

C.E.R. Story
EASAMS Ltd.
Lyon Way, Frimley Road
Camberley, Surrey GU16 5EX

Dr. Richard D. Stutzke
Science Applications International Corporation
1710 Goodridge Dr.
McLean, VA 22102

Agapi Svolou
Senior Scientist
Manager of Software Science
Mellon Institute
Computer Engineering Center
4616 Henry St.
Pittsburgh, PA 15213-2683

Kathy Tammen
General Research Corp.
P.O. Box 6770
Santa Barbara, CA 93160-6770

Kenneth C. Taormina
Director, Analysis and Technology Requirements
Teledyne Brown Engineering
West Oaks Executive Park
3700 Pender Dr.
Fairfax, VA 22030

Edward Town
Rockwell International Corp.
2600 West Minister Blvd.
Seal Beach, CA 90740-7644

Larry Tubbs
US Army Strategic Defense Command
DASH-H-5B
106 Wynn Dr.
Huntsville, AL 35807

Charles M. Vairin
Martin Marietta Denver Aerospace
MS L8079
P.O. Box 179
700 W. Mineral Avenue
Littleton, CO 80201

Dr. Brooks Van Horne
TRW
One Federal Systems Park Drive
Fairfax, VA 22033

John L. Walsh
Riverside Research Institute
Washington Research Office
1701 North Fort Myer Drive, Suite 700
Arlington, VA 22209

G. Karl Warmbrod
SPARTA, Inc.
7926 Jones Branch Road
Suite 1070
McLean, VA 22180

Erwin H. Warshawsky, President
JRS Research Laboratories, Inc.
202 W. Lincoln Av.
Orange, CA 92665-1040

Capt. Charles R. Waryk
OSD/SDIO/S/SA
Pentagon
Room 1E149
Washington, DC 20301-7100

Anthony Wasserman, President
Interactive Development Environments
150 Fourth St., Suite 210
San Francisco, CA 94103

Gio C. Weiderhold
Department of Computer Science
Stanford University
Stanford, CA 94305-2085

Bruce White
500 Montezuma Avenue, Suite 118
Santa Fe, NM 87501

Dave J. Whitley
Software Engineering Section
SCICON, Ltd.
Wavedon Tower
Wavedon Village
Milton Keynes, England MK178LX

John Wiley
BDM Corporation
2227 Drake Avenue
Huntsville, AL 83505

John D. Wolfe
Programmer/Analyst
Software Consulting Specialists, Inc.
P.O. Box 15367
Fort Wayne, IN 46885

Juan A. Wood
Los Alamos National Laboratory
Receiving Department
Bldg. SM-30
Bikini Road
Los Alamos, NM 87545

Richard M. Wright
0/96-01 B/30E
2100 East St. Elmo Road
Austin, TX 78744

Robert C. Yost
Corporate Vice-President
Director, Defense Research & Analysis Operation
SAIC (Science Applications International Corporation)
1710 Goodridge Dr.
McLean, VA 22102

Christine Youngblut
17021 Sioux Lane
Gaithersburg, MD 20878

Steve Zelazny
Science Applications International Corporation
4232 Ridge Lea Road
Amherst, NY 14226

Gerald A. Zionic
NTB Program Director
Martin Marietta Information & Communication Systems
P.O. Box 1260
Denver, CO 80201-1260

CSED Review Panel

Dr. Dan Alpert, Director
Center for Advanced Study
University of Illinois
912 W. Illinois Street
Urbana, Illinois 61801

1 copy

Dr. Barry W. Boehm TRW Defense Systems Group MS 2-2304 One Space Park Redondo Beach, CA 90278	1 copy
Dr. Ruth Davis The Pymatuning Group, Inc. 2000 N. 15th Street, Suite 707 Arlington, VA 22201	1 copy
Dr. Larry E. Druffel Software Engineering Institute Shadyside Place 480 South Aiken Av. Pittsburgh, PA 15231	1 copy
Dr. C.E. Hutchinson, Dean Thayer School of Engineering Dartmouth College Hanover, NH 03755	1 copy
Mr. A.J. Jordano Manager, Systems & Software Engineering Headquarters Federal Systems Division 6600 Rockledge Dr. Bethesda, MD 20817	1 copy
Mr. Robert K. Lehto Mainstay 302 Mill St. Occoquan, VA 22125	1 copy
Mr. Oliver Selfridge 45 Percy Road Lexington, MA 02173	1 copy

IDA

General W.Y. Smith, HQ	1 copy
Mr. Seymour Deitchman, HQ	1 copy
Mr. Philip Major, HQ	1 copy
Ms. Karen H. Weber, HQ	1 copy
Dr. Jack Kramer, CSED	1 copy
Dr. Robert I. Winner, CSED	1 copy
Dr. John Salasin, CSED	1 copy
Dr. Cathy J. Linn, CSED	100 copies
Dr. Joseph L. Linn, CSED	1 copy
Mr. Michael R. Kappel, CSED	1 copy
Mr. Howard Cohen, CSED	1 copy
Ms. Deborah Heystek, CSED	1 copy
Dr. Reginald Meeson, CSED	1 copy
Dr. Karen Gordon, CSED	1 copy
Dr. Norman Howes, CSED	1 copy
Dr. Dennis Fife, CSED	1 copy
Dr. Cy Ardoin, CSED	1 copy
Ms. Julia Sensiba, CSED	2 copies
Albert J. Perrella, Jr., STD	1 copy
IDA Control & Distribution Vault	3 copies