

NASA Contractor Report 3535

**Future Orbital Transfer
Vehicle Technology Study**

Volume I - Executive Summary

Eldon E. Davis

CONTRACT NAS1-16088
MAY 1982

19980819 152

NASA

400160

PLEASE RETURN TO:

BMD TECHNICAL INFORMATION CENTER
BALLISTIC MISSILE DEFENSE ORGANIZATION
7100 DEFENSE PENTAGON
WASHINGTON D.C. 20301-7100

NASA Contractor Report 3535

Future Orbital Transfer Vehicle Technology Study

Volume I - Executive Summary

Eldon E. Davis

*Boeing Aerospace Company
Seattle, Washington*

Prepared for
Langley Research Center
under Contract NAS1-16088

NASA

National Aeronautics
and Space Administration

**Scientific and Technical
Information Office**

1982

Use of trade names or names of manufacturers in this report does not constitute an official endorsement of such products or manufacturers, either expressed or implied, by the National Aeronautics and Space Administration.

1. Report No. NASA CR-3535		2. Government Accession No.		3. Recipient's Catalog No.	
4. Title and Subtitle FUTURE ORBITAL TRANSFER VEHICLE TECHNOLOGY STUDY VOLUME I - EXECUTIVE SUMMARY				5. Report Date May 1982	
				6. Performing Organization Code	
7. Author(s) Eldon E. Davis				8. Performing Organization Report No.	
9. Performing Organization Name and Address Boeing Aerospace Company P. O. Box 3999 Seattle, WA 98124				10. Work Unit No.	
				11. Contract or Grant No. NAS1-16088	
12. Sponsoring Agency Name and Address National Aeronautics and Space Administration Washington, D. C. 20546				13. Type of Report and Period Covered Contractor Report	
				14. Sponsoring Agency Code	
15. Supplementary Notes Langley Technical Monitor: John J. Rehder Volume I of Final Report					
16. Abstract <p>This study has the objective of identifying missions for future orbit transfer vehicles (1995-2010) and defining the technology, operations and vehicle concepts that satisfy the transportation requirements. Several issues were examined. The first involved comparison of reusable space and ground based LO₂/LH₂ OTV's. Both vehicles used advanced space engines and aero assist capability. The SB OTV provided advantages in life cycle cost, performance and potential for improvement. The second issue was the comparison of an all LO₂/LH₂ OTV fleet with a fleet of LO₂/LH₂ OTVs and electric OTV's. The normal growth technology electric OTV used silicon cells with heavy shielding and argon ion thrusters. In this case, the LO₂/LH₂ OTV fleet provided a 23% advantage in total transportation cost. The third issue dealt with the impact of accelerated technology. An accelerated technology LF₂/LH₂ OTV provided improvements in performance relative to LO₂/LH₂ OTV but had higher DDT&E cost which negated its cost effectiveness. The accelerated technology electric vehicle used GaAs cells and annealing but still did not result in the mixed fleet being any cheaper than an all LO₂/LH₂ OTV fleet. The study conclusion is that reusable LO₂/LH₂ OTV's can serve all general purpose cargo roles between LEO and GEO for the foreseeable future. The most significant technology for the second generation vehicle would be space debris protection, on-orbit propellant storage and transfer and on-orbit maintenance capability.</p>					
17. Key Words (Suggested by Author(s)) Chemical Orbit Transfer Vehicle Electric Orbit Transfer Vehicle Normal Growth Technology Accelerated Technology Life Cycle Cost Launch System and Operations				18. Distribution Statement Unclassified — Unlimited Subject Category 15	
19. Security Classif. (of this report) Unclassified		20. Security Classif. (of this page) Unclassified		21. No. of Pages 62	22. Price A04

FOREWORD

The Future Orbital Transfer Vehicle Technology Study, NASA Contract NAS1-16088, was managed by the NASA Langley Research Center (LaRC) and was performed by the Upper Stages and Launch Vehicles Preliminary Design organization of the Boeing Aerospace Company (BAC) in Seattle, Washington. The NASA Contracting Officer's Representative (COR) was John J. Rehder.

This final report is organized into the following two documents:

Volume 1: Executive Summary (NASA CR-3535)

Volume 2: Technical Report (NASA CR-3536)

The following Boeing personnel were key contributors to this study.

Eldon Davis	Study Manager, Systems Integration and Operations
Jim Jenkins	Configuration and Flight Performance
Bob Conrad	Mass Properties and Structural Design
Harry Whippo	Chemical Propulsion and Refueling
Jack Gewin	Avionics and Electrical Power Turnaround and Checkout
Roger Hall	Reliability and Maintenance
Cal Wilkinson	Thermal Control
Ed Goodrich	Maintenance
Dick Boch	Costing
Ray Sperber	Space Debris Analysis
Maurice Wilkinson	Space Radiation
Dana Andrews, Dick Savage	Transpiration Ballute
Don Grim	Electric Propulsion and Performance
Sid Silverman	Solar Array Analysis
Rebecca Reuter, Kevin Hayes, and Sharon McGee	Documentation Support
Vince Caluori	OTV Program Manager

For further information contact:

John J. Rehder
NASA LaRC
Hampton, VA 23665
(804) 827-3911

Eldon E. Davis
Boeing Aerospace Company
Seattle, WA 98124
(206) 773-4545

CONTENTS

	<u>Page</u>
1.0 INTRODUCTION.	1
2.0 SUMMARY OF KEY FINDINGS AND CONCLUSIONS	3
3.0 SPACE- VERSUS GROUND-BASED OTV SUMMARY	9
3.1 Introduction	9
3.2 Mission Model	10
3.3 Normal Growth Technology Vehicles.	10
3.3.1 Vehicle Descriptions	11
3.3.2 Key Basing Issue Results	15
3.3.3 Cost Comparison.	22
3.4 Accelerated Technology Vehicles	24
3.4.1 Vehicle Descriptions	24
3.4.2 Launch and Recovery	25
3.4.3 Cost Comparison With Normal Growth	26
3.5 Value of Normal Growth Technology	26
3.6 Findings	28
3.7 Recommendations.	29
4.0 ELECTRIC VERSUS CHEMICAL OTV SUMMARY	31
4.1 Introduction	31
4.2 Mission Model	32
4.3 Normal Growth Technology Vehicles.	33
4.3.1 Electric OTV Definition.	33
4.3.2 Chemical OTV Definition	41
4.3.3 OTV Fleet Comparison	41
4.4 Accelerated Technology Vehicles	42
4.4.1 Accelerated Technology Projections	42
4.4.2 System Options and Comparisons	44
4.4.3 OTV Fleet Cost Comparison	47
4.4.4 EOTV Use for GEO Refueling	48
4.5 Findings	49
4.6 Recommendations.	49
5.0 REFERENCES.	51

FIGURES

		<u>Page</u>
2.2-1	SB OTV and Hangar	8
3.1-1	OTV Basing Concepts	9
3.3-1	Aeroassisted Vehicle Maneuver	13
3.3-2	LO ₂ /LH ₂ OTV Configurations.	14
3.3-3	Debris Protection (Meteoroid) Impact	16
3.3-4	Performance Sensitivities	18
3.3-5	Launch System Selection	20
3.4-1	OTV Configuration Comparison—LF ₂ /LH ₂ Versus LO ₂ /LH ₂	25
4.2-1	FOTV High Mission Model Summary	32
4.3-1	EOTV Operational Concept	34
4.3-2	EOTV System Drivers	36
4.3-3	EOTV Recurring Cost Optimization	38
4.3-4	EOTV Recurring Cost Comparison	39
4.3-5	EOTV Configuration—Normal Growth Technology	40
4.4-1	EOTV Accelerated Technology	43
4.4-2	EOTV Cost Comparison—Accelerated Versus Normal Technology	46
4.4-3	Accelerated Versus Normal Technology—Electric OTV	47
4.4-4	Transportation Cost Summary—Mixed Versus All-Chemical Fleets	48

TABLES

3.2-1	FOTV Low Mission Model (1995-2005)	10
3.3-1	Normal Growth Technology Projections—Chemical OTV	11
3.3-2	Unscheduled Maintenance—Space-Based OTV	17
3.3-3	Selected OTV Refueling Concept	19
3.3-4	Launch Vehicle Manifesting Summary	21
3.3-5	OTV Basing Mode Impact on SOC	22
3.3-6	Life Cycle Cost Summary	23
3.4-1	Chemical OTV Life Cycle Cost—Accelerated Versus Normal Technology	26
3.5-1	Value of Normal Growth Technology—LO ₂ /LH ₂ OTV	27
4.3-1	EOTV Normal Growth Technology Projection	34
4.3-2	Performance Parameter Summary—EOTV Options	37
4.3-3	Transportation Cost Summary—Complete FOTV High Mission Model	42
4.4-1	Performance and Cost Characteristics of Accelerated Technology EOTV's	45

ABBREVIATIONS AND ACRONYMS

ACS	attitude control system
ASE	airborne support equipment
BAC	Boeing Aerospace Company
BITE	built-in-test equipment
BOL	beginning of life
C/O	checkout
COTV	chemical OTV
CR	concentration ratio
DDT&E	design, development, test, and evaluation
DOD	Department of Defense
EOL	end of life
EOTV	electric orbital transfer vehicle
EPS	electrical power system
FOTV	future orbital transfer vehicle
GaAs	galium arsenide (solar cell)
GB OTV	ground-based OTV
GEO	geosynchronous Earth orbit
IOC	initial operating capability
I_{sp}	specific impulse
IUS	inertial upper stage
LaRC	Langley Research Center
LCC	life cycle cost
LEO	low Earth orbit
LeRC	Lewis Research Center
LRB	liquid rocket booster
MLI	multilayer insulation
MMTR	mean missions to repair
MPD	magnetoplasmadynamic
MSFC	Marshall Space Flight Center
MT	metric ton
NASA	National Aeronautics and Space Administration
OTV	orbital transfer vehicle
P/L	payload
PPU	power processing unit

RCS	reaction control system
R&D	research and development
ROM	rough order of magnitude
RPS	reusable payload system
R&R	remove and replace
SB OTV	space-based OTV
SDV	shuttle-derived vehicle
SEPS	solar electric propulsion system
SOC	Space Operations Center
SPS	solar power satellite
SRB	solid rocket booster
SRU	space replaceable unit
SSME	Space Shuttle main engine
SSUS	spin-stabilized upper stages
STS	Space Transportation System
t	tonne
\bar{t}	shield thickness
TFU	theoretical first unit
TVC	thrust vector control

1.0 INTRODUCTION

This volume presents a summary of the overall study. The remainder of the introduction identifies the background, objectives and issues, and guidelines. Section 2.0 summarizes key findings and conclusions of the study. The remainder of the document is formatted to emphasize the two system level issues: (1) space- versus ground-based orbital transfer vehicles (OTV) in section 3.0 and (2) electric versus chemical OTV's in section 4.0. Within each issue, mission considerations and implications concerning normal growth and accelerated technologies are included.

Use of trade names or names of manufacturers in this report does not constitute an official endorsement of such products or manufacturers, either expressed or implied, by the National Aeronautics and Space Administration.

1.1 BACKGROUND

Orbital transfer vehicles currently included in the Space Transportation System (STS) are the inertial upper stage (IUS) and two spin-stabilized upper stages (SSUS). When combined with the Space Shuttle, these systems are expected to satisfy most mission requirements through the late 1980's.

Missions beginning in the late 1980's are anticipated to be more ambitious; to satisfy these requirements, NASA has recently focused on two additional types of OTV's for use with the shuttle. These include a reusable ground-based cryogenic stage, as defined in reference 1, and an expendable solar electric propulsion stage (SEPS), described in NASA contract NAS8-33753. Both vehicles can be defined as first-generation systems for their respective technologies.

Numerous studies, including the "Technology Requirements for Future Earth to Geosynchronous Orbit Transportation Systems" (ref. 2), have investigated advanced versions of both cryogenic and electric OTV's. In many cases, however, these studies were done using mission models and/or launch systems which at this time appear rather optimistic or the analysis did not consider all required transportation and orbital support elements.

1.2 OBJECTIVES AND ISSUES

Recognition of the above factors led to the initiation of the "Future Orbital Transfer Vehicle Technology Study." This study had the overall objective of building on the knowledge associated with first-generation OTV's to determine characteristics of the OTV fleet for the post-1995 timeframe. Specific issues addressed were:

1. Would space basing of future OTV's provide an improvement in terms of the total space transportation system and its operations?
2. Is there a role for an electric OTV in transporting cargo between low Earth orbit (LEO) and geosynchronous Earth orbit (GEO) when near-term mission models are employed?
3. Would the use of accelerated technology rather than normal growth alter the results of either of the above issues?
4. What technological advances are necessary and which have the most payoff for future OTV's?

1.3 STUDY GUIDELINES

The key guidelines used in performing the study are listed below. Those followed by an asterisk (*) are from the statement of work; those followed by two asterisks (**) have been mutually agreed upon by NASA and Boeing.

1. Point of departure to first-generation reusable LO_2/LH_2 OTV and SEPS both assumed available by 1988**
2. Technology to be available in 1990**
3. Vehicle to have initial operating capability (IOC) of 1995*
4. Technology to be considered only in terms of OTV application*
5. 1995-2010 time frame to be considered for potential missions with major emphasis on Earth orbital missions*
6. Two levels of traffic models to be considered*
7. Most cost-effective launch system to be selected**
8. Figure of merit to be life cycle cost (LCC) of total space transportation system (1980 dollars)*

2.0 SUMMARY OF KEY FINDINGS AND CONCLUSIONS

2.1 KEY FINDINGS

Principal findings of the study are reported here as responses to questions that address the study issues.

Would Space Basing of Future OTV's Result in an Improved Space Transportation System?

In terms of total transportation costs, there was no clear-cut answer. Cost differences between the basing modes range from an 11% advantage for the space-based (SB) OTV to a 7% advantage for the ground-based (GB) mode, depending on the mode used to recover (return to Earth) the key OTV elements. In the case of the GB OTV mode, the OTV's were to be recovered and reused (expendable OTV's were not cost effective). In the SB OTV mode, propellant tankers were the key element requiring recovery consideration. The significance of the recovery operations was that they had an influence on which launch vehicle would be used which, in turn, was the largest contributor to the mission model total transportation cost. Differences in flight performance, refueling, and orbital support provisions were of secondary importance to the cost comparison.

This issue was analyzed using an advanced space scenario involving a mission model beginning in 1995, covering 11 years, averaging 115t of GEO-equivalent payloads per year, and requiring 182 OTV flights. The basing issue was analyzed from a total transportation standpoint which involved all systems and operations necessary for launch and recovery, orbital support, and performance of the OTV mission itself. A permanently manned base was used to the best advantage of both basing modes. OTV's investigated were considered as second-generation reusable systems using LO₂/LH₂ propulsion and normal growth technology available as of 1990.

The most cost-effective launch system for the advanced space scenario involved use of both the Space Shuttle and a solid-rocket shuttle-derivative vehicle (SDV). The shuttle was used to launch personnel, supplies, and a portion of the OTV payloads. The SDV launched the majority of the payloads, OTV's, and/or propellant tankers. Cargo return (to Earth) capability was not provided by the initial SDV investigated. Design provisions were considered for the SDV that would allow cargo return, although this approach was judged to have relatively high technical risk concerning reentry control and payload survival with water landings.

The SB OTV mode was found to provide an 11% cost advantage for the case where return cargo capability was not provided by the SDV. This advantage was the result of the SB mode being able to resort to an expendable tanker but still use the SDV. The GB OTV

mode, however, could not tolerate an expendable OTV (due to cost) nor were there sufficient numbers of shuttle flights to return the OTV's. This situation required the switch to a launch vehicle with return capability, such as the liquid-booster growth shuttle. Launch cost (per unit mass) was higher with this vehicle than with the combination of shuttle plus SDV, and this was the major contributor to the cost penalty of the GB OTV.

Should the higher risk SDV cargo return mode be considered, both basing modes would benefit in relation to the results of no SDV cargo return capability. In this case, the GB OTV mode showed the greatest improvement, resulting in a 7% cost advantage. Contributing to the result is the fact that both OTV modes used the same launch vehicles; however, the GB OTV does not require a tanker and has less space base support cost.

In addition to cost, other factors were assessed to determine if differences existed between the basing modes. The SB OTV was found to provide advantages in terms of flight performance, launch manifesting, and more rapid access to GEO. The performance advantage of 6% in payload for a fixed propellant loading occurs even after provisions were incorporated for on-orbit maintenance and space-debris protection. More effective launch manifesting occurs because with on-orbit propellant storage capability, launches involving GEO-type payloads can also include a tanker loaded with enough propellant to ensure a mass limited launch condition. A more rapid access to GEO also results from there being an OTV and propellant storage availability at a LEO space base. Missions that may require this feature include rescue of a manned system, servicing of a critical space system (assuming spares are available at the base), or special reconnaissance. The SB OTV could initiate the mission in less than 1 day because it is kept in a state of readiness except for refueling.

In summary, the cost difference between the basing modes was not overwhelming; however, the SB OTV mode can provide operational advantages and has a greater cost improvement potential with use of accelerated technologies.

Is There a Role for an Electric OTV in Transporting Cargo to GEO?

This issue must be viewed in the context of total OTV transportation requirements. An electric OTV (EOTV) with long delivery times (cost optimum of 180 days) and much exposure to Van Allen radiation does not satisfy the delivery needs of most payloads or high priority missions such as manned and DOD payloads requiring rapid delivery. These requirements, however, can be satisfied by a chemical OTV. Consequently, the issue

becomes that of comparing two different fleets: the first is a mixed fleet of high-performance electric OTV's for trip-time-insensitive cargo plus chemical OTV's for high priority missions; the second is a fleet of chemical OTV's for all missions.

When viewed from this standpoint, the all-chemical SB OTV fleet provided a 23% advantage in transportation life cycle cost over the mixed fleet when normal growth technology was used. High production costs for the EOTV, in addition to the need for a chemical OTV, were the major contributors to the higher cost of the mixed fleet.

These results were based on a mission model that began in 1995, had a 16-year duration, and averaged 300 t/yr of GEO-equivalent payloads of which 110 t/yr were judged to be EOTV compatible. The launch vehicle fleet again consisted of a basic STS and SDV with reusable payload system (RPS). The EOTV used technologies that were considerably improved over those provided by SEPS, which was the assumed first generation electric OTV. Principal features of the power generation system were silicon cells that were 3% more efficient, six times larger, 25% as thick, and 50% as costly. Electric propulsion employed argon ion thrusters with twice the specific impulse and power processors with specific masses only 25% as large. The most dominating factor regarding sizing and ultimately the cost of the EOTV was the solar array degradation caused by Van Allen radiation. One LEO to GEO round trip with a lightweight array resulted in a 60% degradation of its initial power. Options investigated to minimize degradation and/or amount of power required were (1) a heavily shielded array, (2) faster transit through the radiation belts using chemical assistance, (3) concentrated arrays, and (4) thrusters using less power (arc jets). The heavy shielding concept using 300- μm cover, 50- μm cell, and 250- μm substrate had the best all-around characteristics when using normal growth technology that did not include annealing or gallium arsenide (GaAs) cells.

Would Accelerated Rather Than Normal Growth Technology Alter the Results of Either of the Above Issues?

Use of accelerated technology provided improvements to all vehicles investigated—however, not to the extent of changing the major conclusion associated with either the basing or fleet makeup issues.

In the case of the OTV basing issue, use of accelerated technology, such as the liquid fluorine/hydrogen (LF_2/LH_2) engine, provided substantial reductions in stage length (25%) and propellant loading (15%). Life cycle costs, however, were not appreciably different from the normal growth technology vehicle because of higher design, development, test, and evaluation (DDT&E) and production costs. The SB OTV tended to benefit more from

this technology because the reduction in propellant could be reflected in fewer SDV tanker launches.

Accelerated technology had a significant payoff for EOTV's. The most significant improvement was that of removing radiation damage by annealing. Little cost difference was found between silicon and GaAs solar arrays when both incorporated annealing features. The lower performance and slightly higher radiation sensitivity of the silicon cells were offset by their better effectiveness in terms of annealing and lower unit cost. The most advanced accelerated technology EOTV investigated reduced the average unit cost by 50% relative to the normal growth EOTV. However, when viewed in the context of total OTV transportation requirements, the all-chemical OTV fleet employing normal growth technology still provided a 5% cost advantage, as well as operational advantages over a mixed fleet comprised of chemical OTV's and accelerated technology EOTV's.

What Technological Advances Are Necessary and Which Have the Most Payoff for Future OTV's?

Based on the results of the two vehicle-level issues, the OTV having the greatest promise for the 1995-2010 time frame is an advanced, reusable LO_2/LH_2 system. The technologies suggested must be related to a point of departure—in this case a first-generation, ground-based, reusable LO_2/LH_2 OTV with RL-10 IIB main engine and an insulated ballute for aeroassist capability. The most significant critical/enabling technology associated with the second-generation OTV (GB or SB) is that of space-debris protection for large thin-walled cryogenic tanks designed to fracture mechanics criteria. Of particular interest are the shielding benefits provided by composite materials. On-orbit refueling and maintenance are necessary for the SB OTV. In the case of refueling, zero-g propellant transfer provisions must be provided in addition to systems that minimize propellant storage and transfer losses. Maintenance considerations will dictate very high quality components, modularization, and computer-aided self-diagnosis. Normal growth in LO_2/LH_2 engine technology is expected to provide higher performance and longer life. Improvements in ballutes for aeroassist capability should also be pursued in the areas of advanced materials and techniques that would allow use of transpiration cooling, resulting in significant performance gains.

2.2 STUDY CONCLUSIONS

The following conclusions are presented with the assumptions that (1) the basic STS is an operational system, (2) a reusable ground-based LO_2/LH_2 OTV with aeroassist

capability and a space base such as the Space Operations Center (SOC) are firmly in the planning cycle, and (3) GEO-equivalent payload mission models can be as high as 300 t/yr.

1. Reusable LO_2/LH_2 OTV's can serve all general-purpose cargo roles between LEO and GEO for the foreseeable future.
2. Electric propulsion used with photovoltaics may be worthwhile for specialty missions (e.g., high energy, heavy payload, on-orbit stationkeeping) but not for LEO to GEO cargo delivery in the foreseeable future.
3. Space basing of OTV's can provide cost and operational benefits relative to ground-based OTV's.
4. Normal growth LO_2/LH_2 technology efforts (aeroassist and new engine) should continue because they pay for themselves and offer performance margins.
5. Accelerated technology for chemical OTV's does not appear justified if the most cost-effective launch system (SDV) is employed.
6. Key critical/enabling technologies that should be initiated for future OTV's include space-debris protection and propellant storage/transfer.
7. A possible OTV evolutionary path may include the following steps:
 - a. Initiate operation with a shuttle-optimized, ground-based, reusable OTV.
 - b. Once a space base (e.g., SOC) is available, use capability to integrate ground-based OTV/payload and OTV/Earth-return system.
 - c. Switch to full space basing of OTV after key servicing features required by the OTV have been demonstrated at a space base. Key OTV support provisions to be provided by the space base include hangars and propellant storage facilities. A space-based OTV and hangar are shown in figure 2.2-1. The hangar has the dual role of providing OTV protection against space debris and serving as a facility in which to perform maintenance.
8. The most significant reduction in advanced space scenario transportation cost can be achieved through development of a shuttle-derivative cargo launch vehicle. (based on previous cost-per-flight estimates).

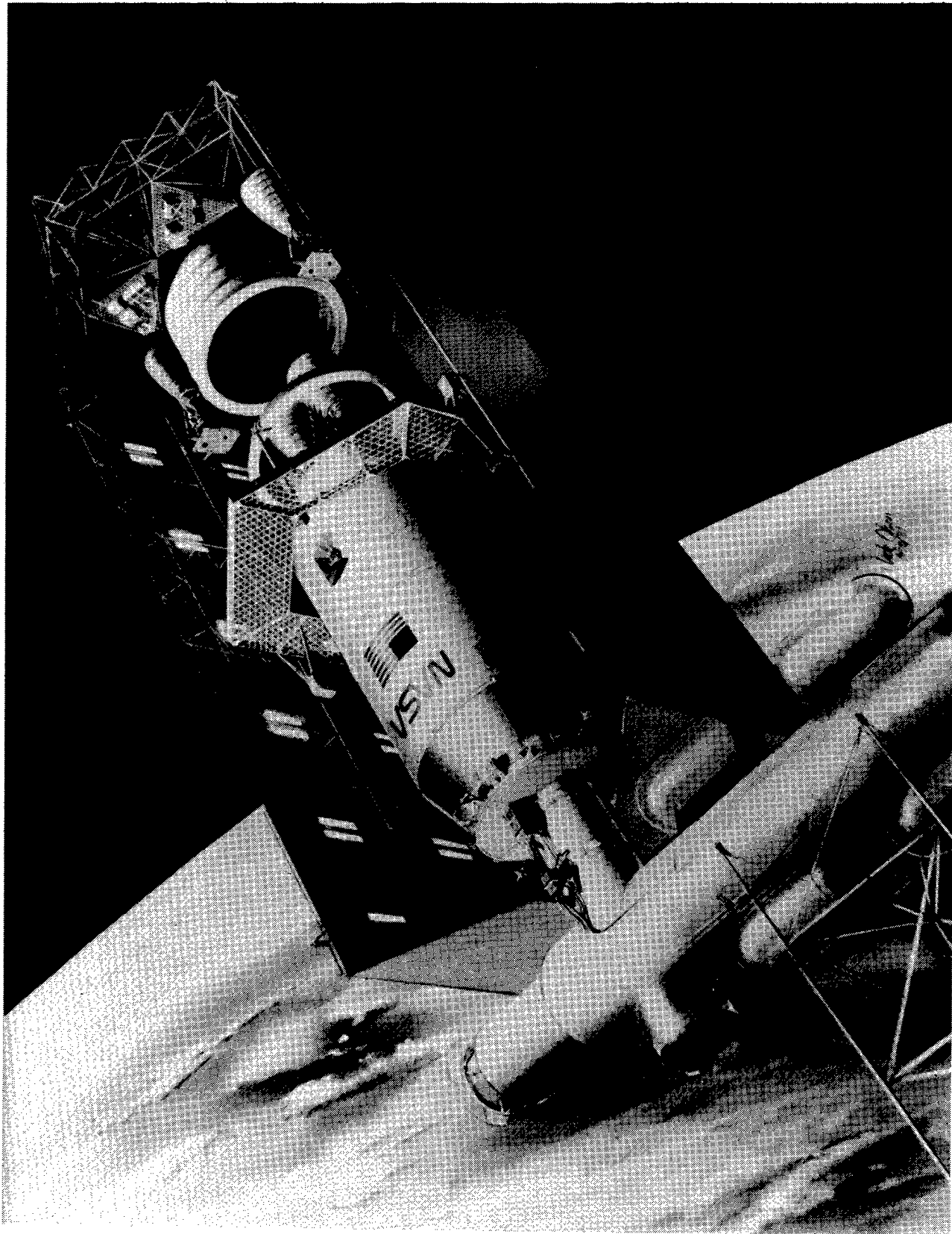

Figure 2.2-1. SB OTV and Hangar

3.0 SPACE- VERSUS GROUND-BASED OTV SUMMARY

Space-based OTV's have been analyzed in other studies and at times compared with ground-based OTV's. In many cases, however, the studies (1) were limited by the amount of data available on related support systems, (2) involved only a comparison of flight performance, or (3) did not consider all related aspects of space transportation and operations. The future OTV (FOTV) study, however, benefited from the recently completed Phase A OTV studies (ref. 1) and was conducted during the same time period as the Phase A study of an orbital support base, the Space Operations Center (Contract NAS9-16151). With the data from these studies, it was possible to define the design and operational features of a space-based OTV to a level comparable with the ground-based OTV and to provide a detailed system-level comparison.

3.1 INTRODUCTION

The scope of the OTV basing mode comparison is shown in figure 3.1-1. Once launched, the SB OTV essentially remains on orbit throughout its design life. The GB OTV

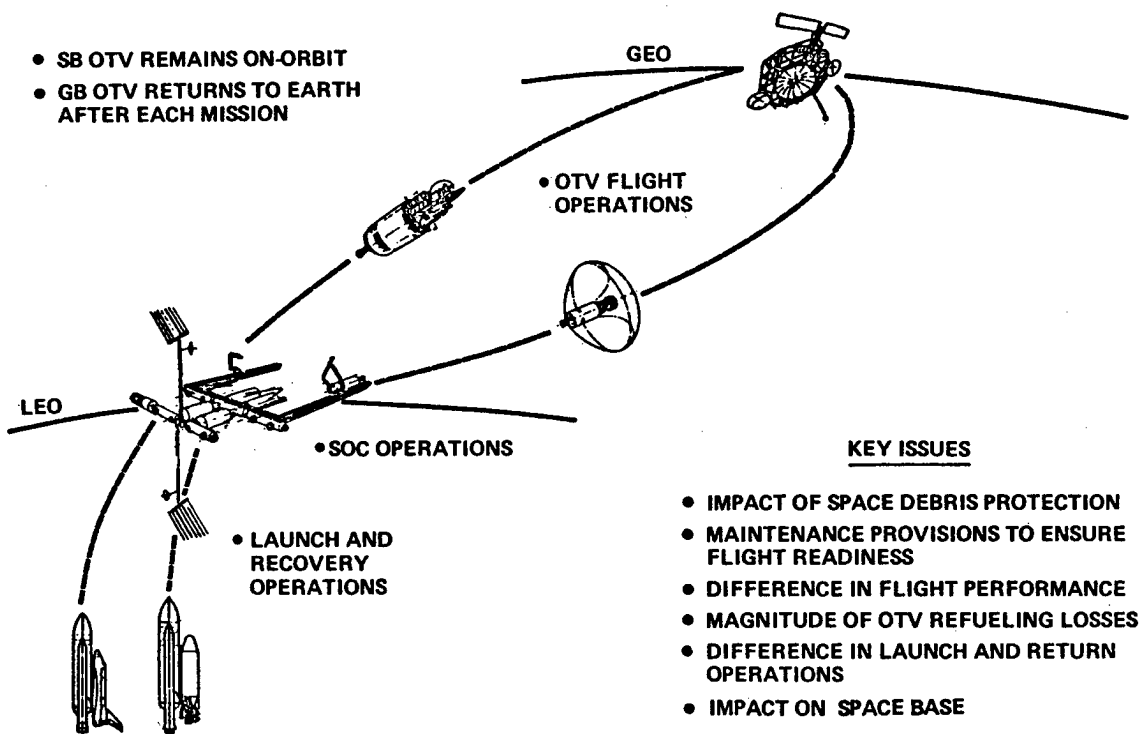



Figure 3.1-1. OTV Basing Concepts

is returned to Earth after each flight to allow servicing. The scope of an integrated transportation assessment of basing modes includes (1) all launch and recovery operations, (2) all operations necessary at an orbital base, and (3) all operations associated with the actual OTV flight. Areas expected to show a difference between basing modes are indicated as key issues and are discussed in subsequent paragraphs.

3.2 MISSION MODEL

The mission model used to assess the OTV basing modes is shown in table 3.2-1. This model is an expanded version of the MSFC Phase A OTV nominal model (rev. 2).

Table 3.2-1. FOTV Low Mission Model (1995-2005)

CATEGORY	MISSIONS	PAYLOAD QTY	PAYLOAD MASS (EACH IN M.T.)	UNIQUE REQMTS 
● COMMERCIAL	● PERS COMMUN	6	25	0.1g & ON ORBIT CONST 0.2g & ON ORBIT CONST
	● TRUNKLINE COMMUN	8	7 & 32 (1)	
	● SMALL SAT.	6	5	
● DOD	● CLASS 1A, 1B, 2, 3	39	3-11	CL3 0.1g (OTHERS 1-3g)
● SCIENCE SYSTEMS	● MEDIUM SAT.	2	7-11	0.1-0.2g
	● SMALL SAT.	6	5	
● GEO BASE	● MODULES & EQUIP	5	9-20	
● MANNED ROUND TRIP	● MAINT SORTIES (LEO)	11	5.9/5.9	
	● BASE CREW ROTATION/RESUPPLY	26	7.6/5.0	
	● SCIENCE SORTIES	2	8.1/8.1	
● UNMANNED SERVICING	● SUPPLIES	63	4	
● PLANETARY	● C ₃ = 55 KM ² /SEC ²	6	5	
● GEN. SERVICE	● SP. BASE RADAR	2	11	0.1g
FOTV TOTAL		182	1280 MT (115 MT/YR)	
PHASE A REV 2		131	740 MT (50 MT/YR)	

 3g LIMITED UNLESS SPECIFIED

More commercial platforms are included, and a GEO manned base occurs early in the model rather than at the end as with the Phase A model. Approximately 40% more payloads are involved, whereas while the GEO delivery equivalent mass (accounts for round trip payloads) is more than twice that of the Phase A model.

3.3 NORMAL GROWTH TECHNOLOGY VEHICLES

Normal growth vehicles are defined as those based on technology and operational capability that should occur as a result of current or planned expenditures. It should be

noted that a number of topics discussed in this section reflect the use of the selected launch vehicle family which consists of the basic STS and an SDV. The STS is used to launch crews and some payloads, whereas the SDV delivers OTV's, tankers, and most of the payloads.

3.3.1 Vehicle Descriptions

Technology Projections. Technology for the future OTV's was to be available by 1990. A summary of these projections relative to the assumed first-generation system is presented in table 3.3-1. Although improvements are identified in all subsystems, the most significant involve the ballute and main engine. The ballute is an inflatable device used to

Table 3.3-1. Normal Growth Technology Projections—Chemical OTV

SUBSYSTEM	BASELINE OTV (BAC PHASE A)	FOTV	BENEFIT
● STRUCTURE			
● TANKS	ALUM	NO CHANGE	—
● BODY SHELL	G/E SANDWICH	BETTER PROPERTIES	10% IN WT.
● AVIONICS RING	ALUM	G/E	40% IN WT.
● BALLUTE	INSULATED	TRANSPIRATION COOLED	50% IN WT.
● THERMAL CONTROL			
● RADIATOR	NO HEAT PIPES	WITH HEAT PIPES	10% LESS WT & AREA
● AVIONICS	PASSIVE	ACTIVE	20% NET WT REDUCTION
● AVIONICS	● REDUNDANT IMU ● SIGNAL CONDITIONERS	● LASER GYRO ● DATA BUS	{ 35% LESS POWER 30% LESS WT IMPROVED RELIABILITY
● ELECTRICAL POWER			
● FUEL CELLS	● MODIF. SHUTTLE	● ADVANCED	● 38% IN POWER/WT
● BATTERIES	● Ni H ₂	● ADVANCED	● 30% IN WHR/LB
● MAIN ENGINE	● RL-10 IIB	● NEW LO ₂ /LH ₂ ENGINE	● ISP = +23 SEC (485 vs 462) ● 100% IN LIFE (10 vs. 5 hrs) ● WT + 15 KG
● ATTITUDE CONTROL	● N ₂ H ₄ ● DECAYING THRUST	● NO CHANGE ● FIXED THRUST	● CONTROL AUTHORITY DURING DOCKING

reduce most of the vehicle velocity prior to insertion into LEO via drag rather than propulsion. Transpiration cooling of the ballute is accomplished by redesigning the Phase A OTV ballute structure to reduce or eliminate the insulation, thereby increasing porosity to provide natural cooling (ref. 3). The benefit of this approach is a 50% weight reduction (coolant plus bag) for the ballute unit and a 60% reduction in packaging volume. A new main engine is also projected for the future (second-generation) OTV. Key benefits are the higher specific impulse (485 versus 464 sec) and longer life (10 versus 5 hr).

Space-Based OTV Description. The SB OTV is initially launched without propellant and payload. The vehicle is based at an orbital space base in LEO. Payloads, fluids, and spares for the OTV are delivered to the base by the Earth launch system. Before each flight, the OTV is serviced in terms of scheduled and unscheduled maintenance, payload mating, and loading of consumables and flight programs. Flight operations for a typical LEO to GEO transfer involve a total delta V of 4300 m/s. The return trip requires a GEO to LEO transfer orbit burn, an aerobraking maneuver to reduce the velocity to near LEO circularity, a circularization burn into LEO, and docking at the orbital base for a total delta V of 2200 m/s. Highlights of the aeroassist maneuver are illustrated in figure 3.3-1. Once back at the base, the OTV is housed in a hangar which serves a dual role of providing space debris protection and a facility to perform maintenance. Housekeeping needs for the OTV (power, thermal, and data links) are provided by the orbital base.

The configuration of the SB OTV is shown in figure 3.3-2. The vehicle has an overall length of nearly 14.2m and a gross weight of 37 700 kg for the design reference mission of GEO base crew rotation/resupply mission. Major structural elements include the body shell and main propellant tanks. The body shell sustains all flight loads and consists of a honeycomb sandwich design using composite skin panels. An aluminum plate is attached inboard of the shell with the combination of both elements providing meteoroid/space debris protection for the main propellant tanks. The 2219-T87 aluminum tanks have been designed for a 45-flight life. Main propulsion is provided by two 66.7-kN-thrust engines. A hydrazine system provides all propulsion for attitude control and small velocity changes. Oxygen/hydrogen fuel cells located in the intertank area supply primary electrical power. Avionics equipment includes that necessary for guidance and navigation, communication, data management, rendezvous and docking, data measurement, and built-in-test equipment (BITE). Thermal control consists of multilayer insulation (MLI) blankets around the main propellant tanks and active radiators for the avionics and fuel cells. The transpiration-cooled ballute used for the aeromaneuver is stowed near the engine. Design provisions incorporated for on-orbit maintenance (remove and replace)

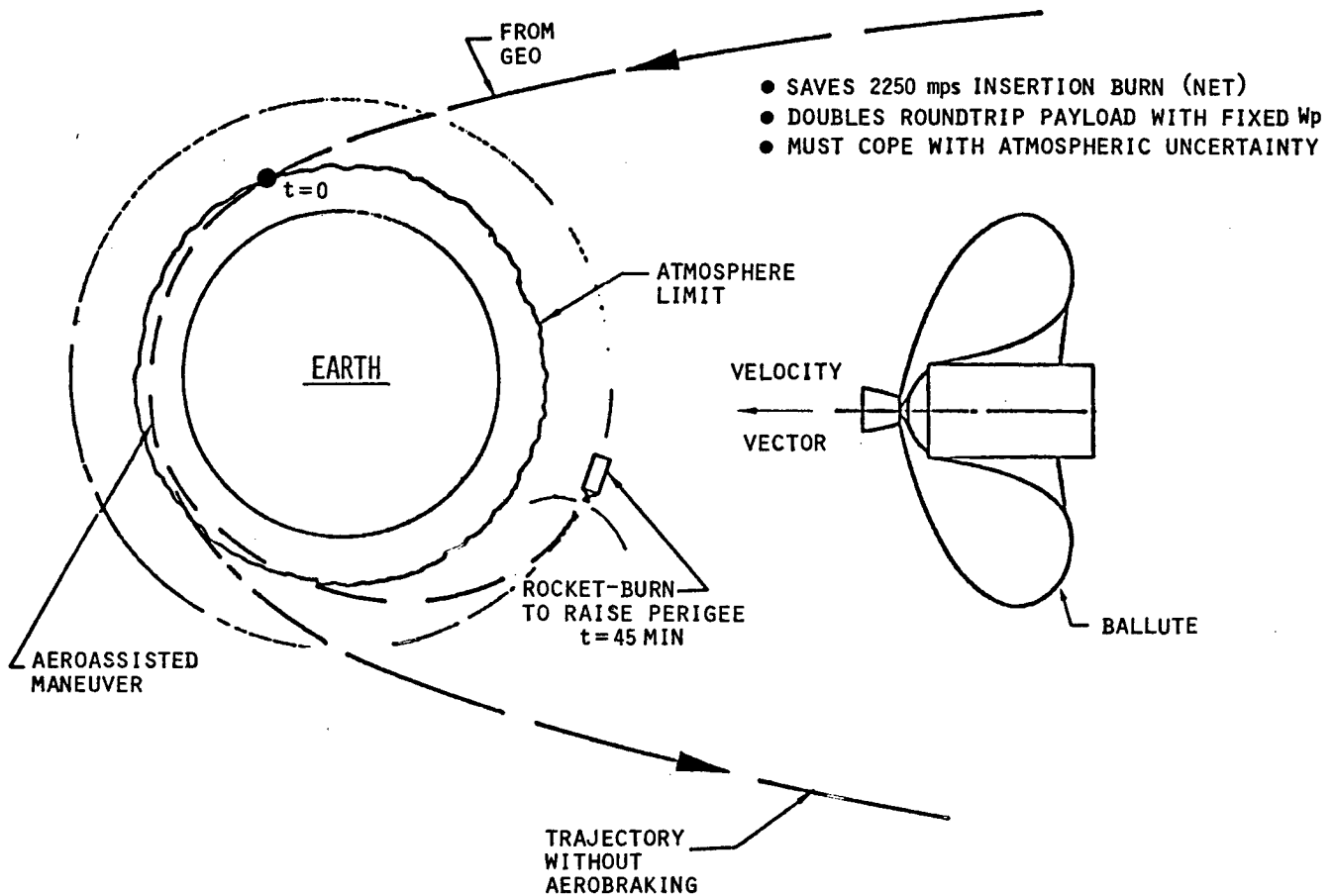

t = 0 sec h = 400,000 ft t = 64 sec h = 292,000 ft t = 100 sec h = 265,000 ft t = 120 sec h = 261,000 ft

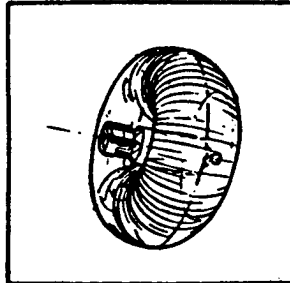

OPEN LH_2 VALVE TO CHILL H_2 LINES

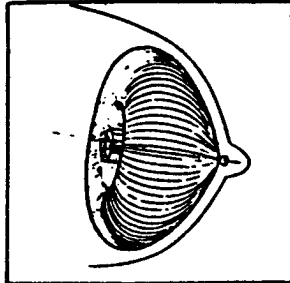

START ENGINE USING TANK HEAD IDLE

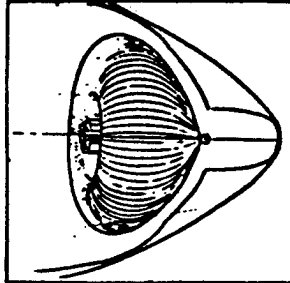

RAISE THRUST TO PUMPED IDLE

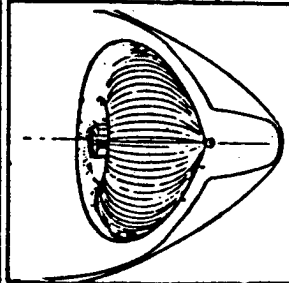

PERIGEE

t = 140 sec h = 262,500 ft t = 250 sec h = 320,000 ft t = 500 sec h = 520,000 ft t = 45 min. h = 400 nmi

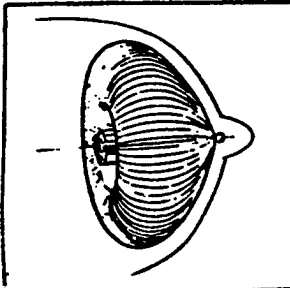

LOWER THRUST TO TANK HEAD IDLE

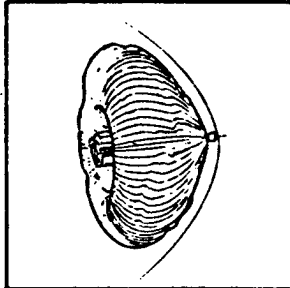

ENGINE SHUTDOWN

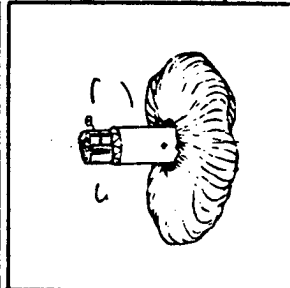

RELEASE RESTRAINING WEBS

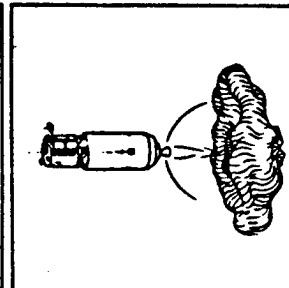

DISCARD BALLUTE DURING APOGEE BURN

Figure 3.3-1. Aeroassisted Vehicle Maneuver

● GROUND BASED

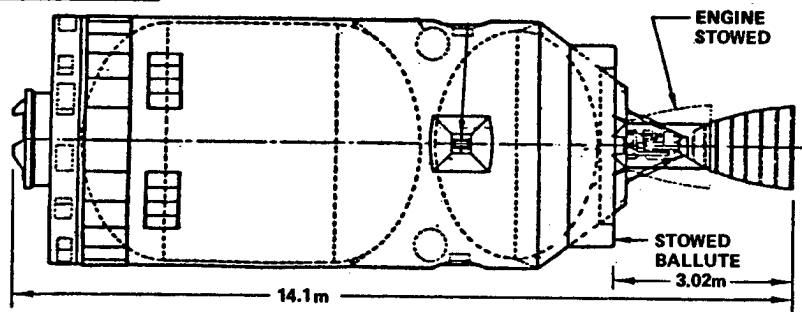

MASS (MT)	GB	SB
● DRY	3.9	3.6
● PROP	33.4	32.5
● GROSS	38.9	37.7
● MASS FRACTION	0.858	0.8638
● PAYLOAD		
● ROUND TRIP	7.6/5.0 MT	
● DELIVERY (0.2g)	12.7	13.0

● SPACE BASED

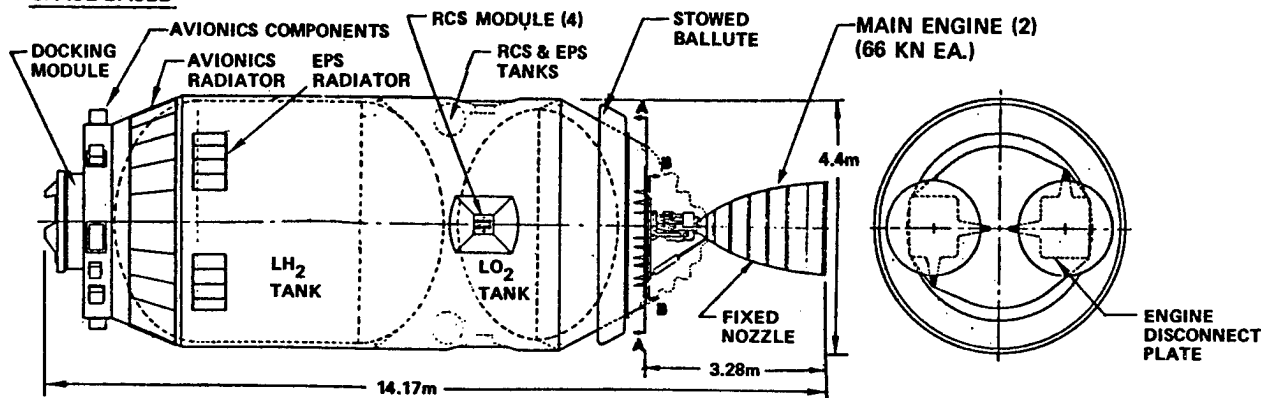

Figure 3.3-2. LO_2/LH_2 OTV Configurations

include external mounting of the avionics and special mounting plates and structural reinforcement for the main engines. Quick removal and replacement design features are also incorporated into the fuel cells and attitude control system (ACS) modules.

Ground-Based OTV Description. The GB OTV is usually launched fully fueled. Payloads can be launched with the OTV or launched separately with integration of the OTV and payload occurring at a space base. The separately launched mode was found to considerably improve the effectiveness of the GB OTV. Flight operations are the same as for the SB OTV. Upon returning to LEO, the OTV docks at the space base, followed by placement within the launch vehicle recovery system for return to Earth. Once back on Earth, all necessary maintenance is performed on the OTV and its airborne support equipment (ASE).

Two sizes of GB OTV were defined. The configuration of the larger one is shown in figure 3.3-2. This vehicle is sized for the same mission as the SB OTV and has an overall length of nearly 14.1m and a gross weight of 38 900 kg. The general appearance of this vehicle is very similar to that of the SB OTV. Major differences are slightly larger

main propellant tanks, a full diameter avionics/equipment ring assembly, and retractable nozzles on the main engines. The slightly larger tanks are necessary to accommodate an increase of 861 kg (nominal plus reserve) in main propellant mass. The full diameter avionics/equipment ring assembly is a preferred configuration for payload accommodation during launch and ascent to LEO and for internal packaging of avionics/equipment. There are no provisions for space maintenance.

A smaller GB OTV was also defined. This vehicle was sized to enable the launching of two vehicles at once by the shuttle-derivative launch system. In summary, the GB OTV is a shortened, single-engine version of the large GB OTV. The length is 10.5m and the gross weight is 26 783 kg, including 22 677 kg of main impulse propellant. The resulting payload capability was 7130 kg for delivery only, or a round trip payload of 3860 kg.

3.3.2 Key Basing Issue Results

Space-Debris Protection. Space debris includes both manmade objects and meteoroids. The manmade debris consists of active and inactive spacecraft and transportation elements and any small fragments that are in orbit. The debris model used was essentially the same as that used in Apollo, Skylab, and Space Shuttle. Meteoroids dominate the model between LEO and GEO, while manmade debris is the major contributor for operations occurring in LEO. The space debris protection goal assumed was 0.995 in terms of not hitting the propellant tank. This value, when combined with subsystem reliability, satisfied the total vehicle reliability goal of 0.97.

The impact of satisfying the space-debris protection goal on a per-flight basis is shown in figure 3.3-3. For the indicated design criteria, a shielding thickness (\bar{t}) of 0.62 mm (aluminum equivalent) is required, assuming a double wall design. The shield is made up of the body shell which serves as a bumper, an aluminum backwall, and the MLI. Fracture mechanics criteria do not allow tank walls to contribute to \bar{t} . The mass impact of providing this protection, relative to designs that do not, is also shown in the figure. A mass penalty of nearly 500 kg for the SB OTV and 200 kg for the GB OTV results when adequate debris protection is provided. To provide the required protection for the SB OTV during its on-orbit storage (time between flights), a \bar{t} of 1.05 mm is required. This protection was provided by placing the OTV in a hangar. In this manner, the SB OTV does not have to incur an additional structural penalty which would impact performance.

Reliability and Maintenance. Reliability and maintenance analyses were performed to determine what provisions were necessary to enable the OTV to have a 0.97 probability of mission success on each flight. The selected systems resulted in the GB OTV having a

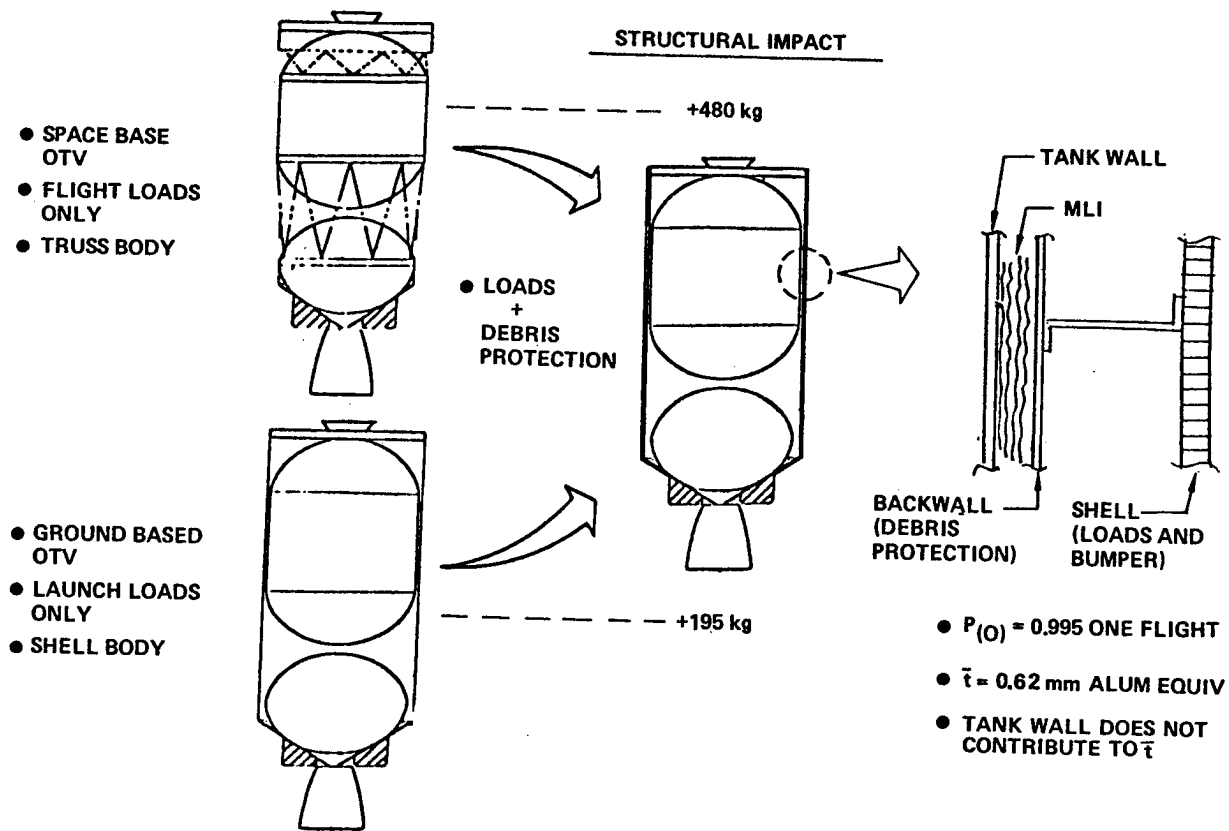

Figure 3.3-3. Debris Protection (Meteoroid) Impact

mission success probability of 0.986 while the SB OTV had 0.978.

Unscheduled maintenance (repair of random failures) of the SB OTV was viewed as particularly important because the impact of providing capability to handle all or most circumstances would be the greatest. The analysis was based on the results of a reliability assessment that identified the components which were failing and the rate. The results of the unscheduled maintenance analyses are summarized in table 3.3-2. These data indicate that, should no maintenance capability be provided, there would be an average of one component failure per flight. Should the failed unit not be repaired, the predicted reliability level for the next flight would be lower than desired. As an alternative, the vehicle could be returned to Earth after each flight but this would be uneconomical. The selected approach was to provide the means to remove and replace the indicated space-replaceable units (SRU). This enabled the OTV to remain on-orbit, except once in every 29 flights when a failure for which there was no maintenance capability provided, would require a return to Earth.

To obtain the on-orbit maintenance capability, however, there is an impact on the vehicle as well as the space base. Each SRU must have design features such as simplified

Table 3.3-2. *Unscheduled Maintenance—Space-Based OTV*

ISSUES --- IS MAINTENANCE NECESSARY?
 --- WHAT'S REQUIRED TO ENSURE A REASONABLE
 ON ORBIT STAYTIME

SRU's	FREQUENCY OF EARTH RETURN (NO. OF MISSIONS)	TOTAL MASS IMPACT (kg) [1]	MAINT TIME (HRS) (PER UNIT) [2]
• NONE	1.06	—	—
• ACS THRUSTER MODULES	4.75	12	2.0
• PLUS FUEL CELLS	7.38	12	4.0
• PLUS MAIN ENGINES	11.7	104	7.0
• PLUS AVIONICS MODULES	29.07	42	1.5

[1] PLUS BUILT IN TEST EQUIP (64 kg)
 TOTAL MASS IMPACT = 234 kg

[2] CREW OF 3

mounting provisions and quick disconnect electrical and fluid connections. These features resulted in a mass penalty of 234 kg, including that associated with the built-in-test equipment. A maintenance crew of three could perform the removal, replacement, and checkout operations in the indicated time. A hangar would be beneficial to provide necessary lighting, containment of personnel and spares, and storage area for spares and maintenance equipment; however, a shirtsleeve environment does not appear necessary.

Flight Performance. Performance sensitivities of the SB and GB OTV's are shown in figure 3.3-4. In terms of end-of-mission weight, the GB OTV reflects structure designed to sustain Earth launch loads with fully loaded propellant tanks. The SB OTV weight includes provisions for space maintenance and additional penalty for debris protection. With the design reference payload, the SB OTV requires 3% less propellant. If viewed in terms of a fixed propellant load, the SB OTV would provide 6% more payload. Each vehicle can also be flown in a two-stage configuration and deliver up to 32t to GEO or have a round-trip payload of 12.4t up and 10.5t down. In summary, the SB OTV still provides a flight performance advantage; however, the extent of the margin is small as a result of its on-orbit provisions and the fact that aeroassist maneuvers benefit GB OTV more because of their heavier end-of-mission weight.

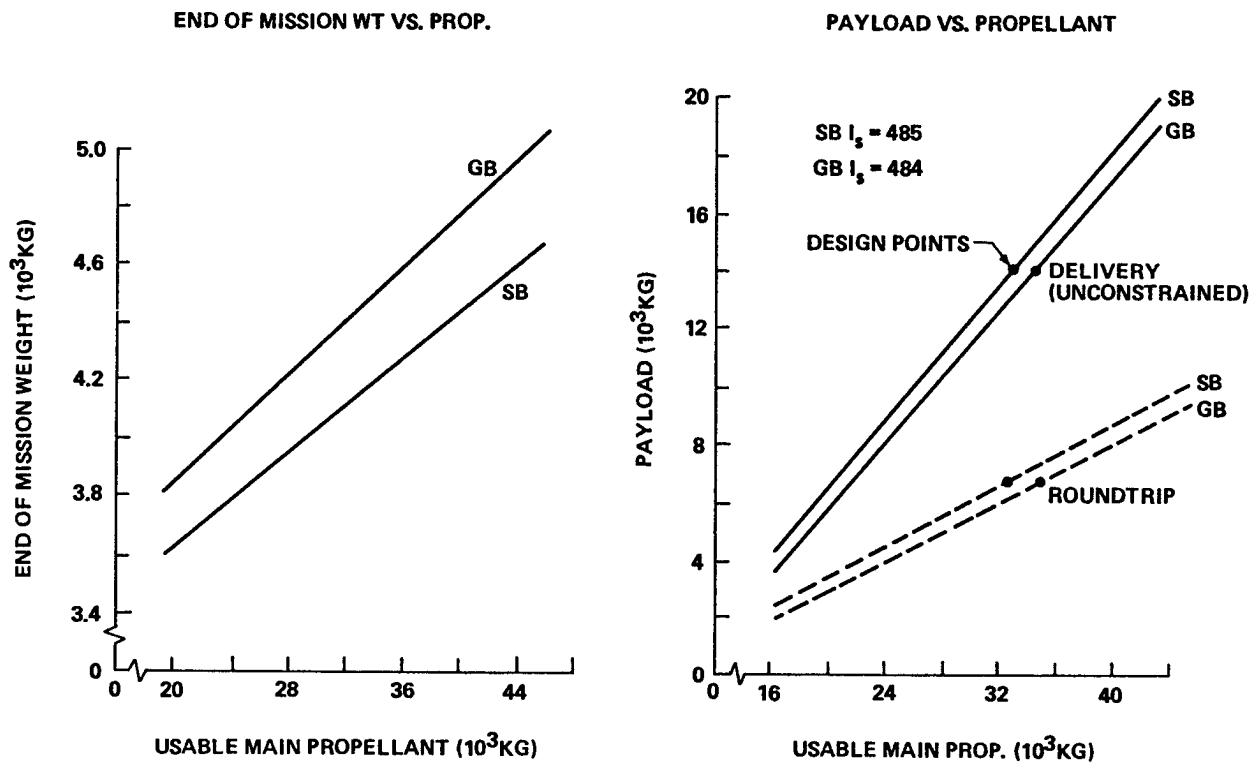

Figure 3.3-4. Performance Sensitivities

On-Orbit Refueling. A major issue associated with the on-orbit refueling of an SB OTV is the losses associated with the delivery, storage, and transfer of propellant. The major system elements in the refueling operations are (1) the tanker which delivers propellant from Earth to the SOC, (2) the SOC storage tanks (referred to as tank sets as each contains an LO₂ and LH₂ tank), and (3) the OTV.

Eight refueling concepts were analyzed for the storage and transfer of propellant from storage tanks to OTV. All used helium for transfer between the tanker and storage tanks. The concepts included several methods of providing pressure, use of liquifiers to reduce losses, subcooled propellant, and exchange of storage tanks when empty. The total refueling mass averaged approximately 500 t/yr. For the concepts investigated, the amount of refueling fluids to be launched over and above the basic mission (flight) requirement ranged from 6% to 14%. The total costs associated with refueling (primarily launch costs) had a 5% spread between the lowest and highest cost concepts.

The concept of recovered vapor pressurization was selected based on factors of risk, operational complexity, and cost. Key characteristics of this concept are shown in table 3.3-3. In summary, vapor is produced when saturated liquid in the SOC tank is throttled to the lower OTV tank pressure. A portion of the vented vapor is passed through a

Table 3.3-3. Selected OTV Refueling Concept

- ISSUE: THE AMOUNT OF LOSSES ASSOCIATED WITH DELIVERY, STORAGE AND TRANSFER

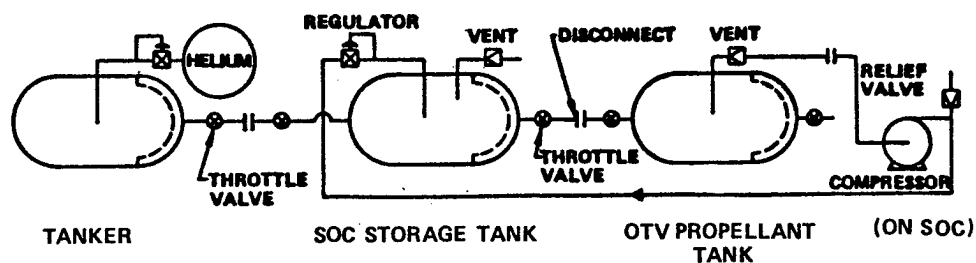

SOC STORAGE TANK FEATURES	TANK SET UTILIZATION				PROP. FLOW (Kg)		
	FLT	DAY	TS 1	TS 2	TANKER	STORAGE	OTV
● QUANTITY (2)	-	0	FULL	F	59090	56990	52350
● CAPACITY 59000Kg * OF LO ₂ /LH ₂	1	20	1/2	F			
● 50 LAYERS OF MLI	2	40	0	F			
● FULL SCREEN ACQUISITION	3	60	F	1/2			
	4	80	F	0			
						LOSSES	LOSSES
					RESID	1340	1800
					BOIL-OFF	120	1600
					CHILL-DOWN RCVR	640	1240
						● TOTAL LOSSES = 6740 KG	

compressor and is returned to the SOC tank to maintain SOC tank pressure. Both the tanker and SOC storage tanks use full screen propellant acquisition systems and MLI for thermal control.



Launch and Recovery. A key task was to determine the most cost-effective launch system for the indicated mission model. Once selected, the system was assessed to determine differences between OTV basing modes in terms of recovery (Earth return of key elements) and detailed launch manifesting.

1. **Launch System Selection**—Launch systems considered and initial comparisons are shown in figure 3.3-5. One option considered only the use of the basic STS. Another, the shuttle growth, replaced the solids with liquid rocket boosters. A third used the basic STS for crew and cargo and a shuttle derivative (SDV) for cargo only. In the SDV, the Orbiter was replaced by an expendable payload shroud and a reusable propulsion/avionics module. The fourth option was similar to the third except that it had liquid rocket boosters instead of solids. Indicated characteristics for these vehicles were obtained from previous NASA studies (refs. 1 and 4) with costs updated to 1980 dollars. Life cycle cost comparisons of the options indicate the least-cost system by a considerable margin is the combination of the basic STS and

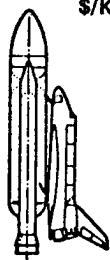
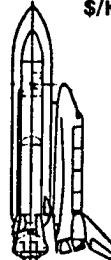
● CREW/CARGO VEHICLES

STANDARD SHUTTLE	SHUTTLE GROWTH (LRB)
<p>*  \$/KG = 970</p> <p>P/L = 29 MT</p>	<p> \$/KG = 570</p> <p>P/L = 47 MT</p>

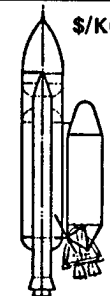
● CARGO VEHICLES

SHUTTLE DERIVATIVE (SOLID ROCKET BOOSTER)	SHUTTLE DERIVATIVE (LIQUID ROCKET BOOSTER)
<p>*  \$/KG = 320</p> <p>P/L = 70 MT</p>	<p> \$/KG = 220</p> <p>P/L = 84 MT</p>

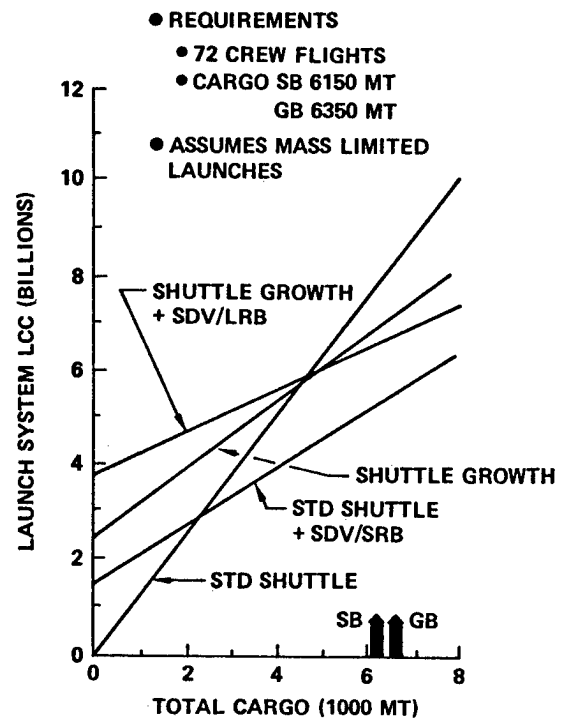







Figure 3.3-5. Launch System Selection





shuttle derivative, using solid rocket boosters. DDT&E and production costs show up at the zero cargo point. The operations cost, indicated by the slope of the lines, reflects 72 crew flights and launching of the indicated amount of cargo (propellant, stages, and payloads for both LEO and GEO).

2. Recovery—The least-cost launch systems, however, only have the capability to return OTV-related elements to Earth with the Orbiter because an expendable payload shroud was used with the SDV. The number of SB OTV propellant tanker flights (118) or the number of GB OTV flights (182) both exceeded the number of Orbiter flights (72); and, thus, an alternate approach was required if these elements were to be reused. The option selected was to use a reusable payload system with the SDV. This concept combines the payload shroud and propulsion/avionics module into one integral unit, making the whole system reusable. In this manner, either OTV's or tankers can be returned. There are, however, penalties associated with this type of system, including a decrease in payload capability to 60t and an additional DDT&E cost of \$100M. It should be mentioned also that reentry and recovery of a reusable payload system present challenging technical problems and must be viewed as having relatively high risk.

3. Launch Manifesting—The number of SDV launches for each basing mode was based on: (1) use of an SDV with reusable payload system and (2) consideration of actual payload lengths and allowable mixes rather than payload mass only. The number of STS launches is the same for all OTV options. Results of incorporating these factors are shown in table 3.3-4 for three OTV options. The first is the traditional GB OTV (one size) which is always launched with its payload. A total of 196 SDV launches are necessary. It should be noted that most of these launches used only 70% of the payload capability. The number of launches was reduced to 138 by using large and small GB OTV's. With the assumed mission model, the small OTV was used in 116 out of 182 missions. The SB OTV concept required the least number of SDV launches because propellant constituted the bulk of cargo to be launched (80%) and it can be loaded in a manner such that almost all launches can be mass limited.

Table 3.3-4. Launch Vehicle Manifesting Summary

STS	GROUND BASED ONE OTV SIZE	GROUND BASED TWO OTV SIZES	SPACE BASED ONE OTV SIZE
	(72)	(72)	TWO TANKER SIZES (72)
● LEO CR/RS	(44)	(44)	(44)
LM + SPM + DM	36	—	—
LM + SPM + P/L + DM	8	—	—
LM + P/L + DM	—	44 	44 
● GEO CR/RS	(28)	(28)	(28)
LM + DM	21	—	—
LM + P/L + DM	7	28 	28
<u>SDV/RPS</u>	<u>(196)</u>	<u>(138)</u>	<u>(121)</u>
● OTV + P/L	182	50 	—
● OTV ONLY	11	85 	—
● GEO P/L ONLY	3	3	3 
● TANKER ONLY	—	—	14
● TANKER + P/L	—	—	91
● OTV + TANKER	—	—	13

 2 P/L (12 FLTS)	 2 P/L (37 FLTS)	 2 P/L EA. FLT	LM = LOGISTICS MODULE
 2 P/L (6 FLTS)	 2 OTV'S/LAUNCH (58 FLTS)		SPM = SOC PROP. MODULE
			P/L = PAYLOAD
			DM = DOCKING MODULE
			RPS = REUSABLE PAYLOAD SYSTEM

Impact on Space Base. The OTV basing mode impact on the LEO space base (assumed to be SOC) is summarized in table 3.3-5. Data for the GB OTV mode are indicative of using two sizes of OTV's. OTV and/or payload handling (mating) operations are nearly as high

Table 3.3-5. OTV Basing Mode Impact on SOC

<u>IMPACT</u>	<u>GROUND BASED OTV (2 SIZES)</u>	<u>SPACE BASED OTV</u>
<ul style="list-style-type: none"> ● HANGAR <ul style="list-style-type: none"> ● DEBRIS PROTECTION ● MAINTENANCE CAPAB. 	<ul style="list-style-type: none"> ● NONE, UNLESS OTV STAYS AT BASE MORE THAN 3 DAYS (DEBRIS PROTECTION) 	<ul style="list-style-type: none"> ● 4 (ONE FOR EACH OTV) ● ONLY ONE WITH MAINTENANCE CAPABILITY
<ul style="list-style-type: none"> ● MAINTENANCE CAPAB. ● CHECKOUT CAPAB. 	<ul style="list-style-type: none"> ● NONE ● OTV/PAYLOAD 	<ul style="list-style-type: none"> ● SCHEDULED & UNSCHED. ● OTV ● OTV/PAYLOAD ● (2) 52 MT TANK SETS AND ALL ASSOCIATED PLUMBING & CONTROL SYSTEMS
<ul style="list-style-type: none"> ● REFUELING 	<ul style="list-style-type: none"> ● NONE 	<ul style="list-style-type: none"> ● (2) 52 MT TANK SETS AND ALL ASSOCIATED PLUMBING & CONTROL SYSTEMS
<ul style="list-style-type: none"> ● DOCKING PORTS 	<ul style="list-style-type: none"> ● OTV (3) ● PAYLOADS (3) 	<ul style="list-style-type: none"> ● OTV (4) ● TANKER (1) ● PAYLOADS (3)
<ul style="list-style-type: none"> ● HANDLING (MATING) PROVISIONS FOR: 	<ul style="list-style-type: none"> ● OTV/OTV (11) ● OTV/PAYLOAD (135) ● OTV/RECOVERY VEHICLE (193) 	<ul style="list-style-type: none"> ● OTV/OTV (11) ● OTV/PAYLOAD (182) ● OTV/RECOV. VEH (6)
<ul style="list-style-type: none"> ● PERSONNEL 	<ul style="list-style-type: none"> ● 1- 2, 10% DUTY CYCLE 	<ul style="list-style-type: none"> ● 3; 40% DUTY CYCLE

with the GB mode, primarily because of the 116 small OTV's launched separately from their payloads. The GB OTV approach also requires considerably more mating operations between OTV and recovery vehicle because all OTV's return to Earth. In the case of the SB OTV, the only OTV and recovery vehicle operations are those which return an OTV for unscheduled ground maintenance. The SB OTV refueling tanker remains within the SDV payload shroud and transfers propellant via lines, thus no handling is necessary. Crew size and duty cycle are greater with an SB OTV; however, their magnitude appears acceptable when considering a nominal crew of eight and the fact that OTV support is one of the three primary roles specified for SOC.

3.3.3 Cost Comparison

Cost comparison of the basing modes involved total transportation costs associated with the mission model. The results are shown in table 3.3-6. Because of the high risk associated with the SDV's reusable payload system, comparisons were made with and without the use of that system. The GB OTV is shown using two sizes of vehicles because the one-size concept required 58 more SDV launches and would not be as cost effective.

Table 3.3-6. Life Cycle Cost Summary

● 1980 DOLLARS IN MILLIONS

<u>HARDWARE ELEMENT</u>	<u>BASELINE COMPARISON (WITH SDV & RPS)</u>		<u>WITHOUT REUSABLE PAYLOAD SYSTEM</u>	
	<u>GB OTV (2 SIZES)</u>	<u>SB OTV (1 SIZE)</u>	<u>GB OTV 2 SIZES</u>	<u>SB OTV (1 SIZE)</u>
● OTV	1975	1700	1975	1700
● TANKER	N/A	730	N/A	1125 (EXPENDABLE)
● SOC SYSTEMS	TBD	205 + TBD	TBD	205 + TBD
● SDV/RPS	4585	4300	N/A	4150
● STS	2060	2060	N/A	2060
● STS GROWTH	<u>N/A</u>	<u>N/A</u>	<u>8600</u> ▶	<u>N/A</u>
TOTAL TO DATE	8620	8995	10575	9240
TBD EST	<u>100</u>	<u>300</u>	<u>100</u>	<u>300</u>
POTENTIAL TOTAL	8720	9295	10675	9540

GB BY \$575 M (5%)

SB BY \$1135 M (11%)

▶ ALL LAUNCHES

The comparison when using a reusable payload system with the SDV indicates the GB OTV mode provides a total transportation cost savings of approximately \$600M, or 7%, compared to the SB OTV mode. The OTV cost increment of the GB mode is greater than the SB OTV primarily because two sizes rather than one were involved. Tanker costs for the SB OTV reflect two sizes and include a total of four units. The SOC system cost is for propellant storage tanks. Both the GB and SB systems have hangar and user costs that are to be determined. A rough order of magnitude (ROM) for the GB OTV is \$100M; an ROM for the SB OTV is \$300M because of additional hangars and personnel. SDV costs are higher for the GB OTV mode because 138 launches are required versus 121 for the SB OTV mode.

The second cost comparison considered the SDV without a reusable payload system, which means the use of an expendable payload shroud. These data indicate the SB OTV mode provides a benefit of approximately \$1.1B, or 11%, compared to the GB OTV mode. The lower cost is primarily due to the SB OTV being able to use a more cost-effective cargo launch system. The SB OTV approach was to continue use of the SDV but to switch to an expendable tanker. In the case of the GB OTV, however, the most effective alternative was to use a launch system that could return the OTV to Earth for servicing and reuse (an expendable OTV was not cost effective). The least-cost launch system satisfying this requirement was the shuttle growth vehicle (see fig. 3.3-5 for launch system cost comparison), but this system had a higher payload delivery cost.

3.4 ACCELERATED TECHNOLOGY VEHICLES

Accelerated technology is defined as that which is judged technically feasible by the 1990 readiness date but which, at this time, is receiving little or no funding to bring about its development. Major emphasis of this analysis was twofold: (1) to evaluate the benefits of an LF_2/LH_2 main engine and a more advanced LO_2/LH_2 main engine and (2) to determine if use of these accelerated technology systems would impact the OTV basing mode.

3.4.1 Vehicle Descriptions

Technology Projections. Principal advantages of the LF_2/LH_2 system, relative to normal growth LO_2/LH_2 , are a higher specific impulse (511 versus 485 sec) and a higher propellant bulk density (612 versus 360 kg/m^3) which results in smaller tanks. Disadvantages include lower design life (7.5 versus 10 hr) and higher DDT&E costs (\$470M versus \$270M).

Improvements in combustion chamber thermal performance and/or turbomachinery efficiencies are projected to increase the specific impulse of the advanced LO_2/LH_2 engine to 499 sec. A 10% weight reduction is also envisioned with lighter weight turbomachinery. The indicated design changes result in a DDT&E cost estimate of \$335M versus \$270M.

Configuration Comparison. The configuration and key characteristics of the SB LF_2/LH_2 OTV are compared with the normal growth SB LO_2/LH_2 OTV in figure 3.4-1. The most notable feature of the LF_2/LH_2 OTV is that it provides a length reduction of 3.7m (25%) when compared with a normal growth LO_2/LH_2 . Major reasons for this reduction are less propellant, due to higher specific impulse, and higher propellant bulk density. Subsystem design approaches for this OTV are the same as for the SB LO_2/LH_2 OTV with the exception of the main engine, and use of helium for LF_2 tank pressurization. In terms of performance, the LF_2/LH_2 system requires 15% less propellant for a given payload; for a fixed propellant load, it provides 25% more payload. The GB and SB LF_2/LH_2 OTV configurations are similar in appearance with the former, requiring only an additional 400 kg of main impulse propellant for the same payload.

The advanced LO_2/LH_2 engine was analyzed for application with an SB OTV only. In terms of performance comparison with the normal growth LO_2/LH_2 engine, propellant

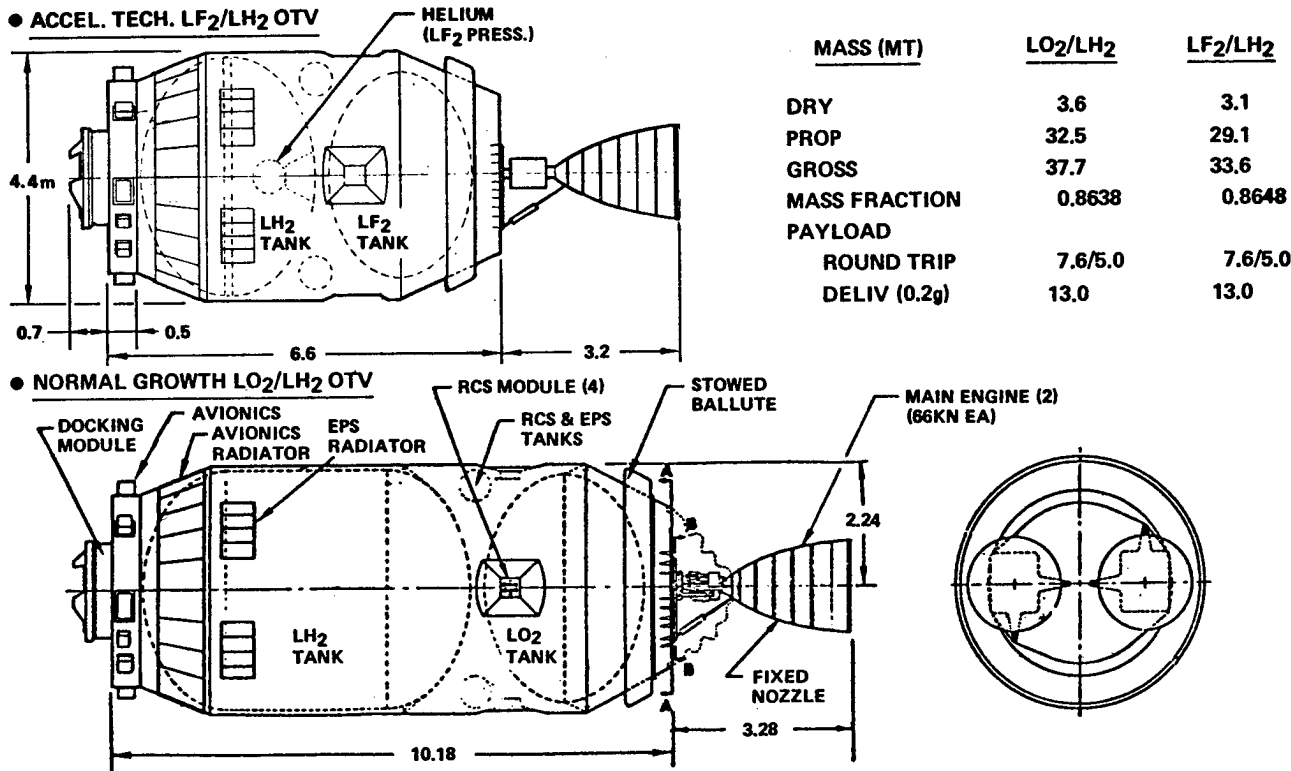

Figure 3.4-1. OTV Configuration Comparison— LF_2/LH_2 Versus LO_2/LH_2

loading was reduced by 6% with a fixed payload; for a fixed propellant load, payload capability was increased by 12%.

3.4.2 Launch and Recovery

The impact of LF_2/LH_2 OTV's on launch operations appears to be more significant for the SB OTV because it reduces the number of launches by 16 relative to the normal growth SB LO_2/LH_2 OTV. This occurs primarily because less propellant is required and it has an ability to mass limit launches by various propellant loadings in the tanker. No recovery operation benefits appear possible because the tankers are too large and too numerous for return by the Shuttle Orbiter. In the case of the two-size GB LF_2/LH_2 concept, benefits occur from increased length and mass margins on each launch, but there is not a reduction in the number of launches. In terms of recovery operations, the small size GB LF_2/LH_2 OTV would be compatible for return; however, with 116 small OTV's and only 72 Orbiter return flights, a mismatch still occurs. A reduction of 6 propellant tanker launches would occur for the advanced SB LO_2/LH_2 OTV relative to the normal growth OTV because of less propellant.

3.4.3 Cost Comparison With Normal Growth

An LCC comparison of accelerated and normal growth technology OTV's is presented in table 3.4-1. These data are for the case of an SDV with a reusable payload system. Should the RPS not be available, the general conclusions regarding the value of

Table 3.4-1. Chemical OTV Life Cycle Cost—Accelerated Versus Normal Technology

- MAIN ENGINE IMPACT
- 1980 DOLLARS (IN MILLIONS)

HARDWARE ELEMENT	HYBRID GB OTV		SB OTV		
	NORMAL LO ₂ /LH ₂	ACCEL. LF ₂ /LH ₂	NORMAL LO ₂ /LH ₂	ACCEL. LF ₂ /LH ₂	ACCEL. LO ₂ /LH ₂
OTV	(1975)	(2275)	(1700)	(1980)	(1770)
• DDTE	815	1045	695	905	765
• PRODUCTION	390	460	365	435	365
• OPERATIONS	770	770	640	640	640
SOC SYSTEMS	(TBD)	(TBD)	(205 + TBD)	(205 + TBD)	(205 + TBD)
TANKER	N/A	N/A	(730)	(730)	(730)
SDV/RPS	(4540)	(4540)	(4300)	(3950)	(4170)
STS	(2060)	(2060)	(2060)	(2060)	(2060)
COST TO DATE	8620	8920	8995	8925	8935
	REFERENCE	+ 300	REFERENCE	-70	- 60

accelerated versus normal growth technology are expected to remain the same. In summary, the accelerated technology OTV's do not provide an LCC which justifies the additional development risk. This is primarily because of higher development and production cost. Consequently, no engine advances beyond a normal growth, new LO₂/LH₂ appear warranted. Finally, the value of accelerated technology appears to be more beneficial to SB than to GB OTV's. This is indicated by both systems having the same cost when using advanced LF₂/LH₂ but the GB OTV having nearly a \$400M advantage when both use normal growth LO₂/LH₂.

3.5 VALUE OF NORMAL GROWTH TECHNOLOGY

The previous section indicated accelerated technology chemical OTV's did not significantly improve total transportation costs over normal growth technology. As a

result, there was an interest in defining the value of the assumed normal growth technology (second-generation OTV) relative to technology assumed available for the first-generation LO₂/LH₂ OTV defined in the Phase A studies (ref. 1).

Results of this assessment are presented in table 3.5-1, where several technology features are examined for two launch system options. These features are associated with

Table 3.5-1. Value of Normal Growth Technology—LO₂/LH₂ OTV

● FOTV LOW MISSION MODEL (1280 MT OF GEO PAYLOADS)
 ● COST REFLECTS NET DIFFERENCE IN DDTE, PRODUCTION AND LAUNCH

TECHNOLOGY FEATURES	LAUNCH SYSTEM	
	STS + SDV	STS ONLY
● NORMAL GROWTH NEW ENGINE NEW BALLUTE	REFERENCE TOTAL COST OF \$9 BILLION	REFERENCE TOTAL COST OF ≈ \$ 11.5 BILLION (+ 27%)
● WITHOUT NEW BALLUTE (BUY NEW ENGINE)	+\$65M (0.7%)	+\$160M (1.4%)
OR		
● WITHOUT NEW ENGINE (BUY NEW BALLUTE)	+\$30M (0.3 + %)	+\$320M (2.8%)
OR		
● WITHOUT NEW ENGINE OR NEW BALLUTE (USE RL-10IIB & STD BALLUTE)	+\$115M (1.3%)	+\$575M (5.0%)
OR		
● WITHOUT ANY BALLUTE (NEW ENGINE/ALL PROPULSIVE)	+\$250M (2.7%)	+\$820M (7.1%)

1 LO₂/LH₂ AT 485 SEC, 10 HR LIFE
 2 TRANSPIRATION COOLED
 3 INCLUDES ALL N.G. SUBSYSTEMS

the engine and ballute as applied to the SB LO₂/LH₂ OTV. Results indicate the penalty for not using normal growth technology is not too significant if the STS plus SDV launch systems are available, but the penalty becomes more significant if only the STS is used. These results can be seen where no new ballute or LO₂/LH₂ engine is used. For the STS plus SDV launch fleet, the penalty is only 1.3% (\$115M); for the STS alone, the cost penalty rises to 5% (\$575M).

As a final note, had the launch system been confined to the STS alone when evaluating accelerated technologies (LF₂/LH₂), results would have been more beneficial than indicated because the higher performance OTV would offset the higher cost launch system. Total transportation costs, however, would have been greater than those from normal growth OTV's using STS plus SDV. The conclusion, therefore, is that SDV procurement in conjunction with normal growth OTV's is more beneficial than accelerated technology OTV's used with the basic STS.

3.6 FINDINGS

Principal findings from the comparison of SB and GB OTV's are summarized below. These findings are highly related to the assumptions used, particularly to that of a first-generation, reusable LO_2/LH_2 OTV with aeroassist capability as the point of departure.

1. **There is no clear-cut winner.** The cost comparison is very dependent on recovery and reuse considerations, available launch systems, and orbital support facility.
2. **Configuration, design features, and performance are very similar.** This was the result of subjecting the SB OTV to a thorough transportation and operations analysis. The most significant impact on the SB OTV was from protection against space debris and provisions for on-orbit maintenance.
3. **Accelerated technology, such as LF_2/LH_2 engines, does not provide a cost benefit.** The engine does reduce stage length and improve performance. A SB OTV is improved more than a GB OTV because the reduced propellant allows fewer tanker launches as long as on-orbit propellant storage capability is available.
4. **Accelerated technology propellant storage/transfer has a payoff.** Concepts have the potential to reduce handling losses from 12% to 5%. Such systems include space-qualified refrigerators and liquefiers.
5. **SB OTV's provide a total transportation cost savings.** For an advanced space scenario using a low-risk shuttle-derivative launch vehicle, without a reusable payload system, and a manned orbit facility, such as the Space Operations Center, a savings of 11% was provided.
6. **OTV stage and propellant tanker return needs are key considerations in launch system selection.** This situation is caused by both length availability in the Shuttle Orbiter, when supporting SOC, and the number of Orbiter flights compared to OTV flights or tanker launches.
7. **The launch system used is the single most dominating factor.** Use of a basic shuttle plus its cargo derivative results in a 15% savings over the next most effective system which uses a liquid rocket shuttle and liquid rocket cargo derivative vehicle.
8. **Mission model size and makeup have the most influence on launch vehicle selection.** The launch vehicle selection, in turn, will influence the selected OTV basing mode.
9. **Space-based OTV impact on SOC appears acceptable.** A crew size of three is required at 40% duty cycle. Hangars are beneficial for maintenance and debris protection. Propellant storage tanks should provide sufficient capacity for an emergency OTV flight at any time.

10. **A space base could provide a valuable role with either a GB or SB OTV.** In the case of the GB OTV, the space base could be used for mating payloads and OTV's to enable more effective launch manifesting. This same function is provided for the SB OTV in addition to supporting the maintenance and refueling operations.
11. **Significant technology efforts are necessary for future OTV's.** The most significant new technology associated with the second-generation OTV (GB or SB) is that of space-debris protection. Refueling and maintenance demonstrations are necessary for the SB OTV. Normal growth in technologies, such as new LO_2/LH_2 engines and transpiration ballute, offers performance, operation, and cost benefits that justify their development.

In summary, SB OTV's offer the lowest total transportation costs for the least-risk approach regarding recovery and reuse and also provide flexibility in launch and flight operations for normal growth technology. In addition, greater potential exists for cost reductions when accelerated technology is employed. Finally, development of a shuttle-derivative cargo launch vehicle is the most significant way to reduce transportation costs in the 1995-2010 time frame.

3.7 RECOMMENDATIONS

The recommendations below are based on the assumption that a reusable LO_2/LH_2 OTV with aeroassist capability is in the procurement cycle.

1. **Continue to investigate the most effective shuttle-derivative launch vehicle.** This is judged extremely important because SDV operation proved the most dominating cost factor. Launch system cost comparisons should be updated to reflect related performance and cost data from the initial Space Shuttle flights rather than from the preliminary design data used in 1977 SDV studies. Cargo return needs must be considered; accordingly, special emphasis should be given to investigating the feasibility of a reusable payload system, its related performance, and its cost features.
2. **Consider the system implications of the following:**
 - a. **An unmanned platform instead of SOC for orbital support.** Although support for SOC is increasing, the required time frame is still somewhat controversial. Accordingly, an unmanned platform that can provide a "parking" location and housekeeping functions for the OTV is a possible precursor to SOC. Costs

associated with crew support for maintenance, launch, and/or revisions to the maintenance provisions onboard the OTV are the key features to be defined.

- b. **A launch system confined to the basic STS.** Although the cost analysis indicated a substantial benefit when using the SDV, this does not ensure its development. Consequently, the effect of the mass and envelope constraints associated with the STS need to be assessed in terms of impact on launch manifesting and number of required launches.

3. **Initiate future OTV technology efforts:**

- a. **Space debris protection studies and demonstrations.** Primary emphasis should be on establishing protection characteristics of materials associated with reusable cryogenic OTV's rather than extrapolation from data developed for habitats or expendable OTV's. Of major interest would be composite materials as well as MLI.
- b. **Propellant storage and transfer demonstration.** Cost effectiveness of the SB OTV is influenced by the additional amount of propellant which must be launched to cover all handling losses associated with its refueling. Further studies need to be performed on the most effective means of accomplishing this function, and relatively large-scale demonstrations of the top contender need to be conducted prior to commitment to an SB OTV.
- c. **Maintenance needs for SB OTV.** Consideration of on-orbit maintenance features should begin during the preliminary design phase of those systems requiring maintenance. Particular attention should be directed to the main engine. Demonstrations of maintenance crew and time requirements also appear warranted before commitment to an SB OTV due to its impact on SOC crew size and related user charges.
- d. **Development of key normal growth technologies.** Most significant of these are a new LO_2/LH_2 engine and a transpiration ballute. Although the cost benefits of these systems over first-generation systems were not significant, when used in conjunction with an SDV, they paid for themselves and provided increased performance when necessary. Moreover, should only the basic STS be available, over 5% in total transportation costs would be saved.

4. **Maintain surveillance of all aerospace products for development of OTV-type subsystems.** The most likely areas will include avionics (laser gyros and data bus), structures (composites), and electrical power generation systems.

4.0 ELECTRIC VERSUS CHEMICAL OTV SUMMARY

4.1 INTRODUCTION

Consideration of an electric OTV for LEO to GEO cargo delivery is based primarily on its high specific impulse (up to 10 000 sec versus 485 sec for LO_2/LH_2 OTV's). Several key disadvantages, however, include: (1) relatively long trip times due to low acceleration, (2) solar array damage when passing through the Van Allen radiation belts, and (3) relatively high costs associated with solar arrays and electric propulsion elements. A favorable comparison of the EOTV with a LO_2/LH_2 OTV, therefore, depends on how well disadvantages can be minimized and whether savings in operation costs can offset expected high production costs.

The comparison of electric versus chemical OTV's must take into consideration total transportation requirements associated with a given mission model. In most cases this means high-priority cargo (rapid delivery), manned missions, and general cargo. Consequently, the comparison involves an assessment of the following OTV fleets:

1. EOTV's for trip-insensitive payloads and chemical OTV's for manned and high-priority cargo
2. Chemical OTV's for all payloads

The major emphasis in this analysis was on defining the EOTV (the chemical OTV was defined in the SB versus GB issue), including both design and operational features. Key issues include:

1. Payload Compatibility - How many payloads could accept the long trip times? Should large payloads be transported as finished systems (LEO construction) or as components (GEO construction)?
2. Van Allen Radiation Impact - This involves the extent of the oversizing of the EOTV due to solar array degradation, design life limits imposed on other EOTV elements, and penalties imposed on payloads being transported.
3. Cost Sensitivity to Trip Time and Isp - Short trip times are desirable from a fleet size standpoint and for minimum radiation degradation; however, the higher thrust levels required mean more electrical power. High Isp reduces propellant requirements but requires more propulsion and, thus, more electrical power. The goal then was to find the combination of Isp and trip time giving the least system cost.

4.2 MISSION MODEL

The mission model for this comparison was developed with an intent that it be large enough that the benefits of a high-performance EOTV could be used. Characteristics of the resulting model are shown in figure 4.2-1. As compared with the model in the SB versus GB OTV analysis (designated as low model), missions have been added in the areas of communication platforms, DOD payloads, science and observation platforms, and manned activity. The model includes 477 payloads, resulting in a total GEO delivery equivalent mass of approximately 4600t, nearly twice the size of the low model. Approximately 45% of this mass is related to round trip payloads.

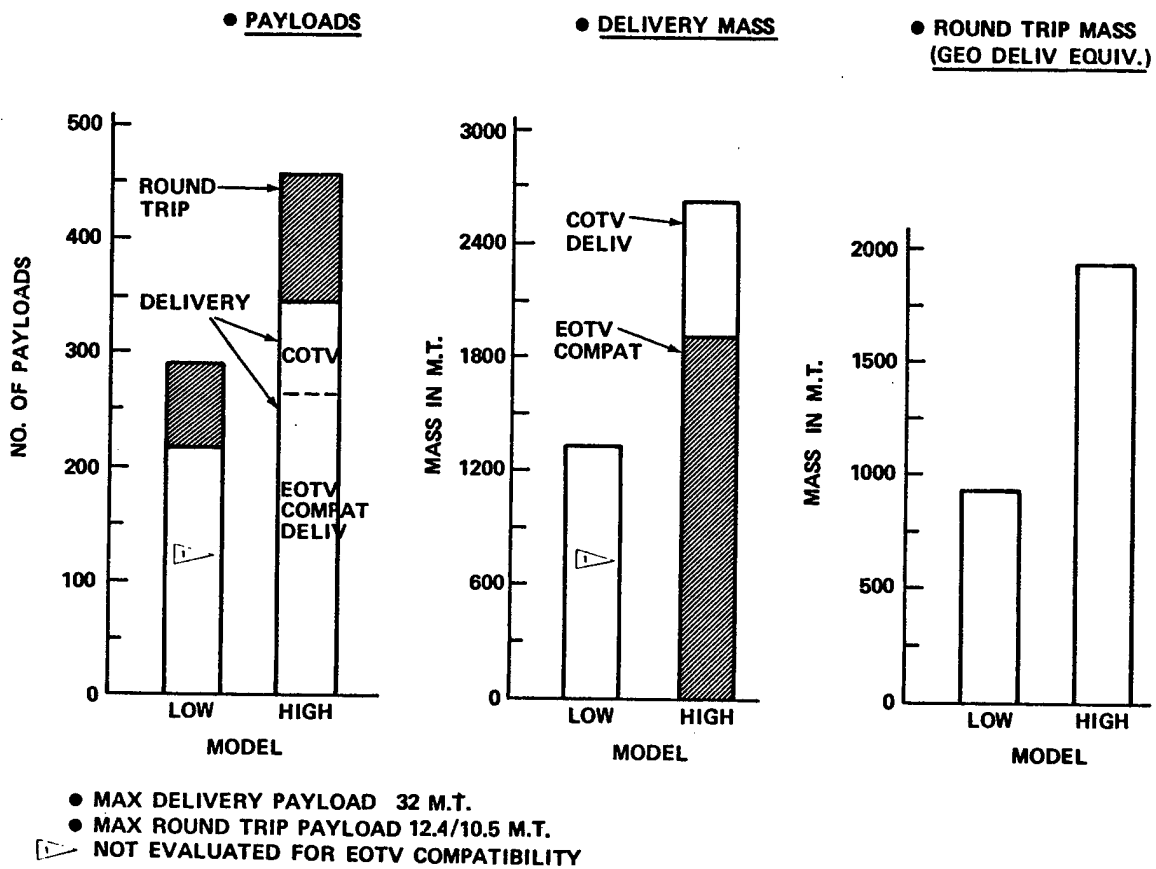

Figure 4.2-1. FOTV High Mission Model Summary

A total of 284 payloads were judged to be EOTV compatible in terms of relatively long trip times. In general, those judged incompatible due to trip times were the manned missions and some DOD missions. The compatible payloads resulted in a delivery mass of approximately 1900t, or 40% of the total model mass, which indicates considerable need for a chemical OTV to satisfy total transportation requirements.

Another compatibility issue dealt with whether payloads requiring construction should be transported from LEO as finished systems or as components with construction occurring in GEO. The recommendation is for transportation as components and construction in GEO. This approach eliminates the problems of docking and attaching large payloads to the EOTV while operating under aerodynamic and gravity gradient forces at LEO. It also eliminates potential flight-control problems during transit. The GEO construction base (eight-man) has been included in the mission model.

4.3 NORMAL GROWTH TECHNOLOGY VEHICLES

This section describes the electric and chemical OTV's judged possible with normal growth technology.

4.3.1 Electric OTV Definition

Use of a low-thrust electric OTV for cargo delivery to GEO requires awareness of those operational features that influence candidate design options and their effectiveness. Contributing to the overall definition was a guideline that the power source be confined to photovoltaics. This decision was based on the judgment that photovoltaics has the most near-term potential and the fact that other power sources are being examined in the "Advanced Propulsion System Concept Study" (Contract NAS8-33935).

Some unique EOTV operational features for LEO to GEO application are summarized in figure 4.3-1. Because of its anticipated size, the EOTV will be based in LEO near the SOC rather than attached to it. Thrust levels are quite low and, as a result, typical transfer times are as long as 180 days. Additional gravity losses result from the low-g transfer, with a one-way delta-V typically of 6000 m/s versus 4300 m/s for chemical OTV transfers. The most effective transfer trajectory involves a continuous spiral with as many as 1000 revolutions during the indicated transfer time. While in sunlight, the array remains pointed toward the Sun to provide continual thrust. Because of the Earth's shadow, however, occultations occur during each revolution until a relatively high altitude is reached. During occultations, attitude is held but no orbit-raising propulsion is applied. Return flights to LEO include the same operations; however, the downtime is usually only 25% to 50% of the up time because the payload is gone.

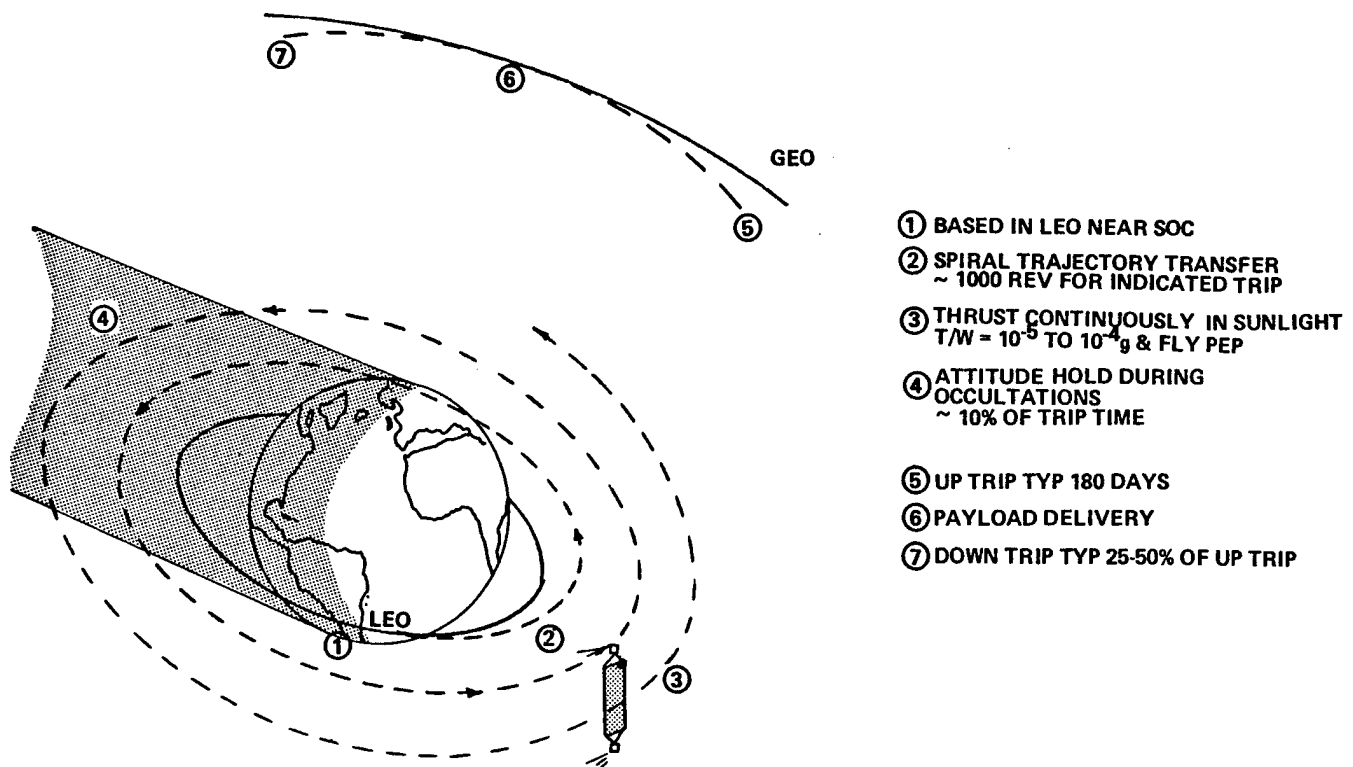

Figure 4.3-1. EOTV Operational Concept

4.3.1.1 Technology Projections

Normal growth EOTV technology projections are presented in table 4.3-1 along with characteristics of the SEPS vehicle, which is assumed to be the point of departure.

Table 4.3-1. EOTV Normal Growth Technology Projection

AREA	1980 (SEPS TYPE)	1990 FOTV
● SOLAR ARRAY		
● CELL (EFF.)	SILICON (13)	SILICON (16) (GaAs ACCEL TECH)
● SIZE	2 x 4	5 x 5
● THICK (MIL)	8	2
● BLANKET		
● MAKE-UP (MILS)	6-8-2	3-2-2 (COVER-CELL-SUBST)
● KG/KW	8.7	2.4
● DEPLOY. & SUPP (KG/KW)	3.1	0.6 (SPACE FABRIC. STRUCT)
● ANNEALING	NO	NO
● ELECTRIC PROPULSION		
● THRUSTER (DIA) ▽	ION (30 CM)	ION (50 CM) ARC
● PROP.	MERCURY	ARGON HYDROGEN
● Isp (SEC)	3000	5-10000 900
● EFF.	72	68-83 90
● POWER PROCESSING		
● (EFF.)	87-90	92 93
● (KG/KW)	13	3.1 1.8
● PPU THERMAL CONTROL	15 (HEAT PIPE)	(5 vs 12 SUPPLIES)
● (KG/KW)		8
		(ACTIVE RADIATOR)

▽ MPD THRUSTER ANALYSIS ASSIGNED TO MSFC/BAC STUDY OF ADVANCED PROPULSION CONCEPTS - - - PROVED NOT ATTRACTIVE

Significant improvement is indicated in all areas.

The solar array for the EOTV consists of the cell, cover, and substrate. Silicon cells are suggested as the only candidate for normal growth. Although GaAs cells are receiving considerable emphasis (including funding), the thin cell design desired by an EOTV still represents considerable challenge and is considered an accelerated technology, which is analyzed in section 4.4. The 16%-efficient silicon cell is assumed to result from the overall average of very large production quantities rather than from laboratory conditions. Improvements are envisioned in cell size, which benefits assembly cost, and in thickness, which reduces radiation degradation and weight. Specific mass of the 1990 array is only 35% that of the 1980 array due to differences in thickness of the cover-cell-substrate. Annealing capability was judged an accelerated technology.

Electric propulsion thrusters in this study were limited to ion and arc-jet systems. Through mutual agreement between the study manager and the NASA COR, magnetoplasmadynamic (MPD) thrusters were not considered because of their special emphasis in the Advanced Propulsion System Concept Study. The projected 50-cm-diameter ion thruster characteristics are indicative of those resulting from studies being conducted by Hughes Research Labs (HRL) and XEOS for NASA LeRC. Argon was selected to eliminate environmental objections associated with mercury when used for LEO to GEO application.

Thermal arc jets are judged obtainable based on work performed in the 1960's and most recently by Dr. Rolf Buhler of the University of Stuttgart. The characteristics reflect a concept with a mixing chamber downstream of the arc chamber to homogenize the propellant which is subsequently expanded in a conventional nozzle.

The ion-jet power processing unit (PPU) improvement in specific mass (3.1 versus 13 kg/kW) is primarily the result of reducing the number of power supplies by combining functions. Efficiencies as high as 92% can be expected. Arc-jet PPU's are expected to have slightly higher efficiency and lower specific mass than ion thruster PPU's because the arc jet requires only a single voltage, typically as low as 100V. Use of an active (pumped fluids) radiator, rather than heat pipe, is expected to reduce the specific mass of the thermal control system from 15 kg/kW to 8 kg/kW.

4.3.1.2 System Drivers

Two key factors which contribute to eventual effectiveness of the EOTV system are solar array power degradation, as a result of Van Allen radiation, and array production costs. The impact of these factors is summarized in figure 4.3-2.

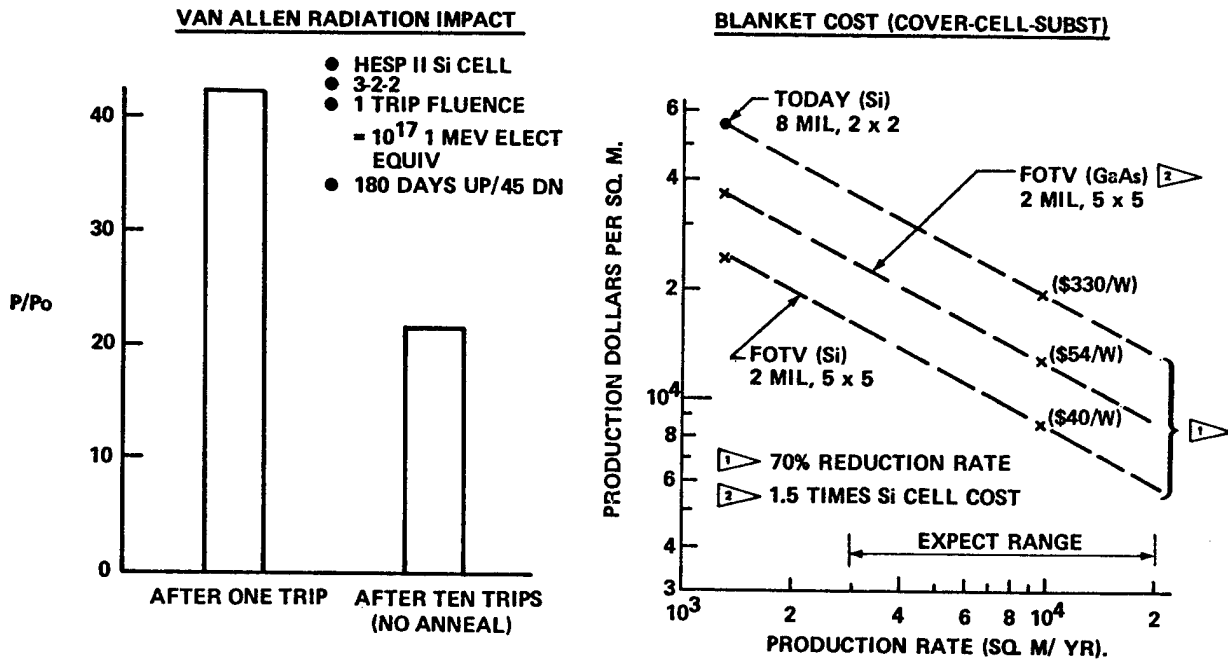

Figure 4.3-2. EOTV System Drivers

In the case of the Van Allen radiation impact, the fluence received from one LEO to GEO round trip with the indicted array is more than 500 times greater than that received in 10 years if located only at GEO. As a result, power output degrades nearly 60%, which gives a power ratio (power available to initial power) of 40%. The desired design life for the EOTV is 10 flights. Accumulation of radiation each flight results in a final power ratio of approximately 20%, indicating the array must be oversized by a factor of 5 when designing for end of life (EOL). Reductions in the extent of the degradation are possible through additional shielding, faster trip times, or starting above the worst portion of the radiation. The effectiveness of these options is discussed in section 4.3.1.3.

The solar array is by far the most expensive element of the EOTV, due in part to its large area and high cost per unit area. Production costs of today's arrays are on the order of $\$55,000/m^2$; however, several factors enable a lower unit cost for the EOTV discussed here. The biggest reduction results from using 5- x 5-cm cells, although a small benefit also results from an advanced thin cell (50 μm). A second factor in EOTV array production costs is that they reflect a 70% cost reduction expected with highly automated production of large numbers of units. Finally, the annual production rate was to reflect a total of nine vehicles during the 16-year mission model. For production quantities of $10^4 m^2/yr$, the silicon array cost is estimated at $\$40/W$, considerably greater than the $\$0.30/W$ used in the EOTV analysis of the solar power satellite (SPS) studies, however far less than

\$330/W if today's cells were used. Although they have been indicated as accelerated technology, costs are also shown for the GaAs cells. Predictions for these cells are even more uncertain than for silicon; the lowest estimate was 1.5 times that of a silicon array for a given production rate.

4.3.1.3 System Options and Comparisons

A listing of the EOTV options and their performance characteristics are presented in table 4.3-2. A point design was developed to serve as a means of comparison as well as to establish basic characteristics of EOTV-type subsystems. This design uses a planar array

Table 4.3-2. Performance Parameter Summary—EOTV Options

PARAMETER	POINT DESIGN	OPTION 1 SHIELDING	OPTION 2 CHEM ASSIST	OPTION 3 CR = 2	OPTION 4 ARCJET
ΔV (ONE WAY) M/S	6000	✓	3550 & 4050	✓	✓
SPECIFIC IMPULSE (SEC) ▷	6000	✓	✓	✓	900
NON THRUST TIME %	15		2	✓	✓
P/PO (10TH FLT @ 180 DAYS)	.22	.45	.54	✓	✓
POWER GEN SYS (Kg/Kw)	4	10	✓	3.5	✓
BLANKET OUTPUT (W/M ²)	179	✓	✓	260	✓
PPU EFF. ▷	92	✓	✓	✓	93
PPU (Kg/Kw) ▷	3.3	✓	✓	✓	2.1
PROP TANKS (% Wp)	4	✓	✓	✓	18
THRUSTER ▷ (Kg/Kw)	1	✓	✓	✓	0.5-1.0
RESERVES (%)	2	✓	✓	✓	✓
RADIATOR (Kg/Kw)	8	✓	✓	✓	✓
ESP STRUCT (% EPS)	15	✓	✓	✓	✓
OTHER SUBSYS (Kg)	2200	✓	✓	✓	✓

▷ PARAMETER VARIES BUT INDICATED VALUE IS TYPICAL
 ✓ SAME AS POINT DESIGN
 ▷ TYPICAL WITH INDICATED ISP

(CR = 1), 75-50-50 μm blanket, ion thrusters, and a self-power transfer mode to perform the entire LEO to GEO flight unassisted. Key features and exceptions to the point design are as follows: Option 1 was to determine whether the reduced degradation brought about by heavy shielding would offset the additional mass. As indicated, the power ratio improved by a factor of 2, but the power generation specific mass increased 2.5 times. Option 2 used chemical OTV assistance to transport the EOTV rapidly to an 11 100-km

altitude, above all or most radiation belts; then the EOTV completed delivery and returned to LEO. EOTV delta-V was reduced but this must be made up by the LO_2/LH_2 OTV which has a much lower I_{sp} (6000 versus 485 sec). The power ratio for the EOTV improved by a factor of 2.5. Option 3 involved a concentrated array (CR = 2) which would reduce the amount of array required. The power output was increased by a factor of 1.45 rather than 2, primarily because of lower cell efficiency when operating at higher temperatures. Option 4 used an arc-jet thruster, which operates at a lower I_{sp} than ion thrusters and requires less power and array. Improvements were also available in specific mass of thrusters and PPU's. A significant penalty in propellant tank mass fraction was the result of arc-jet use of low-density hydrogen propellant rather than argon.

Cost optimization of each option for trip time and specific impulse used the following factors: payload = 25t up/0 down, design life = 10 flights, array sized for end of life (10th flight).

Principal cost elements involved EOTV hardware, launch costs for vehicle and propellant for 10 flights, and the trip time interest cost (relating to interest paid on borrowed money associated with payload and launch costs). Cost optimization of the point design from the viewpoint of trip time and I_{sp} is presented in figure 4.3-3. The left-

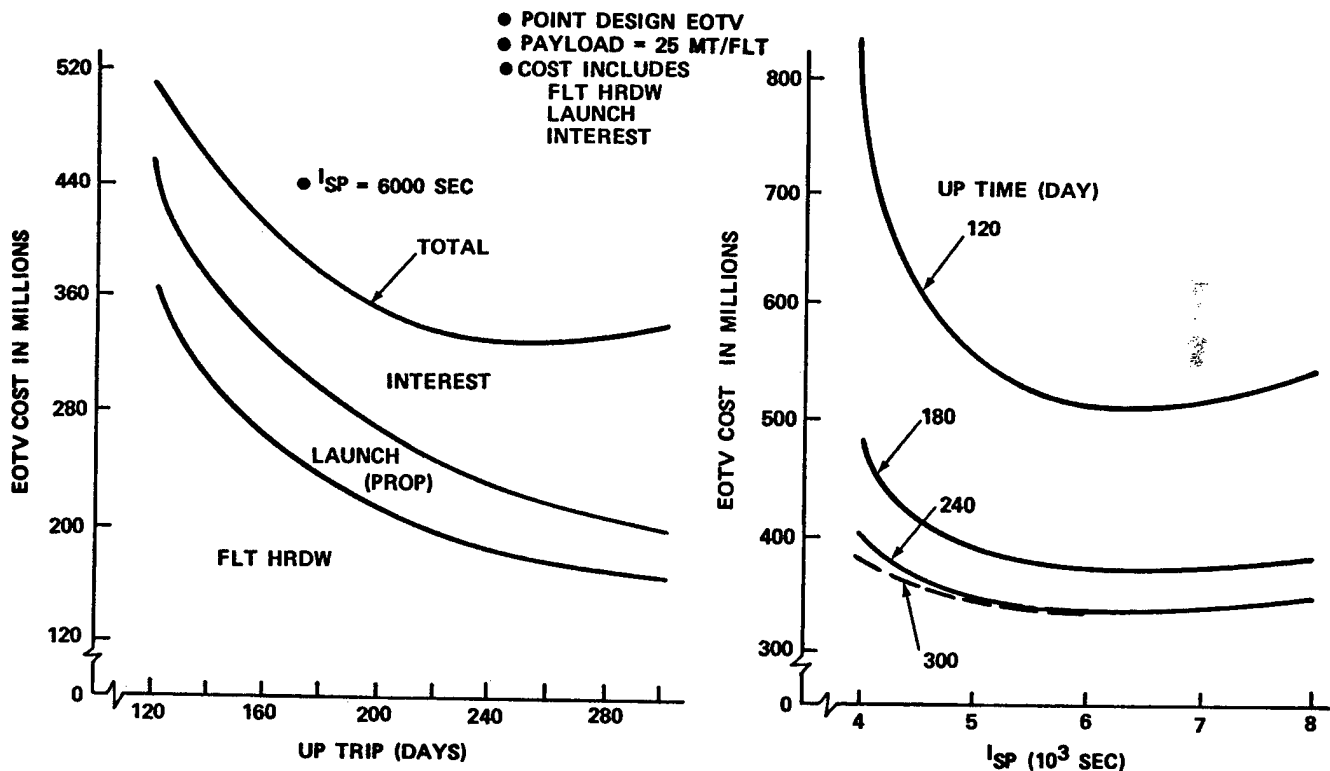

Figure 4.3-3. EOTV Recurring Cost Optimization

hand plot emphasizes the influence of trip time. If considering only traditional cost elements, such as hardware and launch, longer trip times are better. Including the cost of borrowed money (interest), however, moves the optimum trip time back to 220 to 240 days. This plot indicates that hardware costs for one EOTV are much greater than costs for launching the propellant (even for 10 flights)—a dramatic difference from chemical OTV costs. The right-hand plot emphasizes the effect of Isp for several trip times. In this case, the cost optimum for all trip times occurs with an Isp of 6000 sec, although the cost does not vary significantly between 5000 and 8000 sec. The other options had similar optimizations in terms of trip time and Isp (except for arc jet which was fixed at 900 sec but still had the same trip times).

Cost comparisons for all options performing 10 flights are presented in figure 4.3-4. All options are cost competitive with the exception of the arc-jet option, whose biggest cost contributor was for launch of the large amounts of hydrogen propellant. The

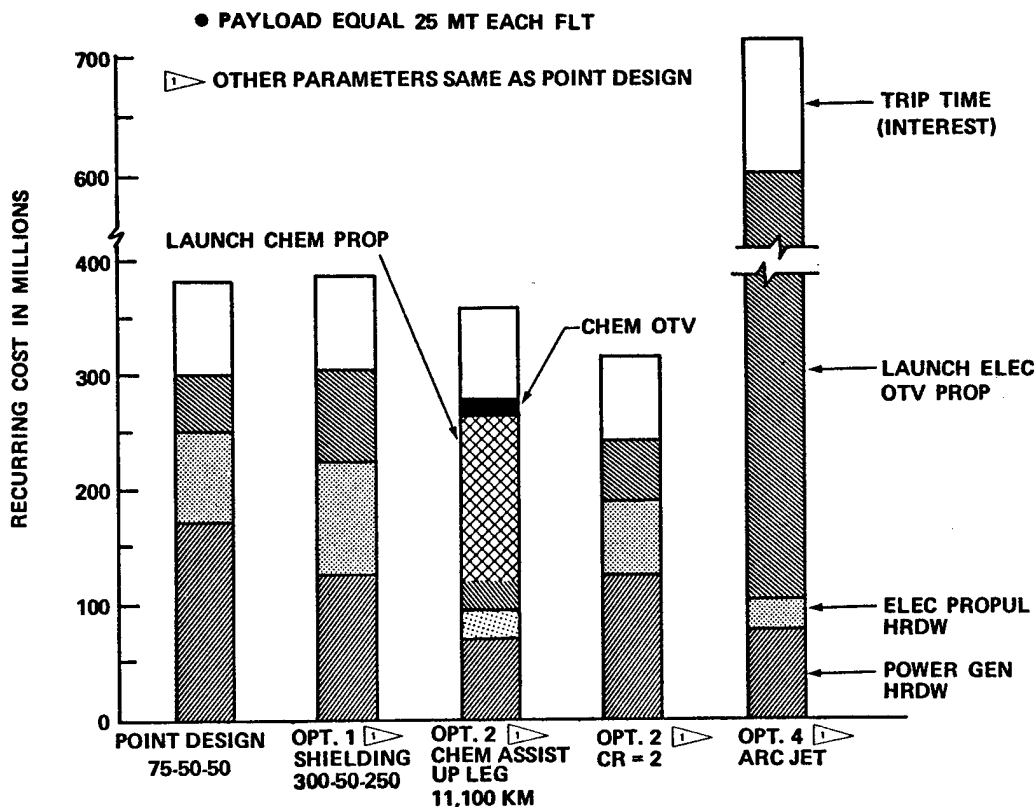

Figure 4.3-4. EOTV Recurring Cost Comparison

chemical-assist option provides the lowest EOTV hardware cost; however, launching of chemical propellant increases costs to nearly the same as for the point design and the heavy shielding option. As compared with the point design, the heavy shielding option

requires less array and thus less power generation cost; but because of being heavier, it requires more electric power system (EPS) hardware and propellant. The CR = 2 option has the least costs, primarily by virtue of its high power output per unit area, relatively low weight, and smaller amount of propellant.

Based on considerations of recurring cost, operational simplicity, constructibility, and "forgiveness" relating to radiation effects uncertainty, the heavy shielding option was selected as the normal growth EOTV.

4.3.1.4 Selected EOTV Description

The configuration and key characteristics of the selected normal growth EOTV are shown in figure 4.3-5. The system is sized to deliver 25t in 180 days using an Isp of 6000 sec. The beginning-of-life (BOL) power is 3600 kW (1600 kW EOL) which requires 19 600

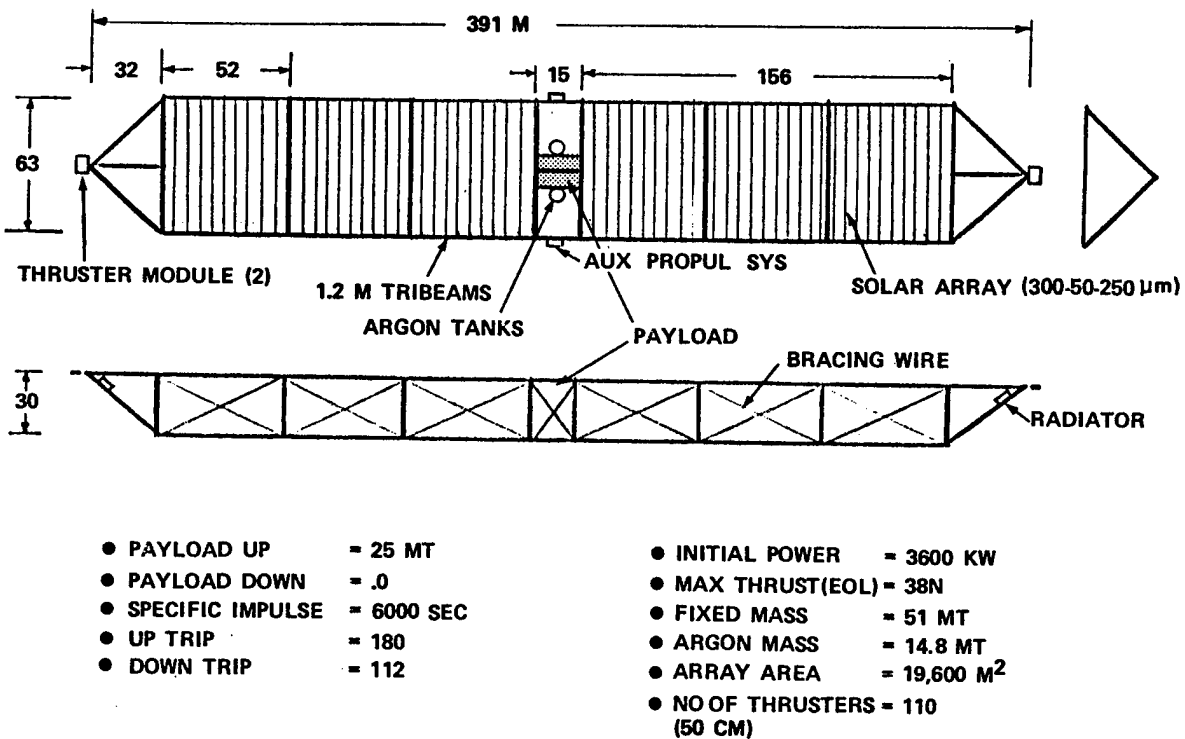

Figure 4.3-5. EOTV Configuration—Normal Growth Technology

m² of 300-50-250 μm array. The main propulsion modules are mounted on the vehicle centerline at each end by a yoke and gimbal system which allows them to be properly directed and operate whenever the vehicle is generating power. The modules contain 100, 50-cm thrusters, producing 38N of thrust, and 110 power processing units. The solar array is designed to dedicate one-half to each main propulsion module. Hydrazine auxiliary

propulsion modules, located at the vehicle center on the lateral axis, provide roll control during flight, stability during occultation, and stationkeeping. The framework is made up of space-fabricated composite tribeams. Payload and propellant are located at the center of the vehicle to provide optimum moment-of-inertia characteristics. Total vehicle dry weight is 51t, of which 14.5t is propellant.

When using a round trip time of 300 days, a total of four vehicles are required in the fleet at any given time. Included within the round trip time are the LEO servicing operations involving payload loading, thruster refurbishment, and propellant loading.

The EOTV average unit cost is \$361M with \$243M related to flight hardware and \$118M for related support. In the case of flight hardware, the solar array accounts for over 50% of the cost.

4.3.2 Chemical OTV Definition

The chemical OTV used in the fleet comparison is the same as that defined in section 3.3.3--an LO_2/LH_2 space-based system, sized for 32 500 kg of main impulse propellant. This vehicle can be used as both a single- or two-stage OTV. When compared with the EOTV, in terms of propellant required for payload delivery of 25t, the chemical OTV requires approximately 54t while the EOTV requires 15t. The average unit cost is \$30M.

4.3.3 OTV Fleet Comparison

An all-chemical OTV fleet was compared to one composed of electric and chemical OTV's (mixed fleet) using the entire mission model defined in section 4.2. The all-chemical fleet required 266 OTV flights while the mixed fleet required 73 EOTV flights and 193 chemical OTV flights. Both fleets required 112 STS launches for crews and cargo. The shuttle derivative was used to launch the majority of cargo and all OTV propellant. The all-chemical fleet required 231 SDV launches and the mixed fleet, 178.

Total transportation life cycle costs for the two fleet options are presented in table 4.3-3 for the total mission model. The all-chemical fleet provided a savings of approximately \$3B, or 25%. This savings results from lower DDT&E, considerably lower production costs, and no delta interest cost, which more than offset higher launch operations costs. The DDT&E difference is due to EOTV development. Production costs are overwhelmed by the high cost associated with the EOTV. Launch costs are less with the mixed fleet primarily because less total propellant is required and, thus, 50 fewer SDV flights. From a front-end-cost standpoint (DDT&E plus one-half of production), the all-chemical fleet is over \$2B less expensive.

Table 4.3-3. Transportation Cost Summary—Complete FOTV High Mission Model

	<u>EOTV + COTV</u>	<u>ALL COTV</u>	• COST IN MILLIONS • 1980 DOLLARS (2240)
<u>DDTE</u>	(3140)		
EOTV	900	—	
COTV	700	700	
TANKER	440	440	
SDV/RPS	1100	1100	
SOC	TBD	TBD	
<u>PRODUCTION</u>	(3495)		(935)
EOTV	2760	—	
COTV	210	360	
TANKER	75	125	
SDV/RPS	450	450	
SOC	TBD	TBD	
<u>OPERATIONS</u>	(8020)		(9205)
EOTV	290	—	
COTV	560	780	
TANKER	130	210	
SDV/RPS (LAUNCH)	3905	5080	
SOC	TBD	TBD	
STS (LAUNCH)	3135	3135	
<u>SUBTOTAL</u>	<u>14655</u>		<u>12380</u>
<u>OTHER</u>			
TRIP TIME (INTEREST)	(605)		(—)
<u>TOTAL</u>	<u>15260</u>		<u>12380</u>

Based on transportation life cycle cost considerations, when both options use normal growth technology, an all-chemical OTV fleet provides a significant advantage over a fleet of electric and chemical OTV's.

4.4 ACCELERATED TECHNOLOGY VEHICLES

The major emphasis in this analysis was to investigate accelerated technology alternatives with potential to reduce the unit cost of the EOTV. Based on results of the normal growth analysis, the area of most interest was that of the solar array.

4.4.1 Accelerated Technology Projections

Solar array accelerated technology projections focused on two areas: (1) improved solar cells performance and/or cost and (2) solar array annealing, which would effectively reduce the amount of oversizing required and, thus, the cost. Projections in these two areas are summarized in figure 4.4-1.

Other than planar silicon cells, only GaAs cells were judged to be adequately characterized in terms of performance, cost (marginal), radiation sensitivity, and annealability (marginal). Cells judged insufficiently characterized were vertical junction, multiband gap, and thin film. The principal value of the GaAs cell over the silicon cell was higher efficiency, less radiation sensitivity, and potential for self-annealing. Disadvantages included cost and mass.

An alternative to heavy shielding to minimize array degradation is thermal annealing. In thermal annealing, irradiated solar cells are subjected to elevated temperatures for certain durations, resulting in the removal of a portion of the damage and, thus, restoration of the power output. The key issue in the annealing operation is not whether it works but its degree of effectiveness in terms of how much damage (fluence) is removed. Projections regarding effectiveness are difficult to obtain for proton damage in silicon cells and even more so in GaAs cells.

Assumed annealing effectiveness is also shown in figure 4.4-1 for several cell types and operating conditions. In general, the values indicated are based on extrapolations from data presented at photovoltaic conferences. In the case of a silicon cell, a post-annealing approach is indicated; i.e., the annealing occurs after total damage for one trip

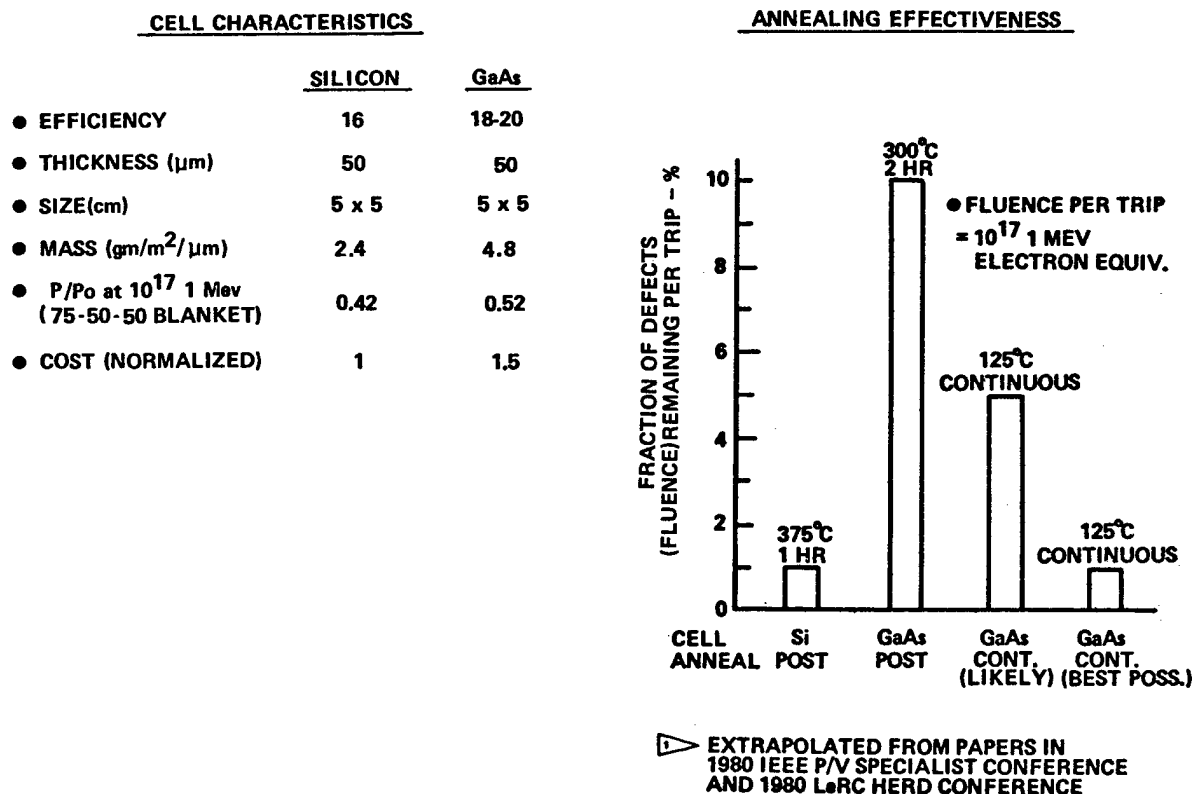

Figure 4.4-1. EOTV Accelerated Technology

has been received. Extrapolations of annealing conditions indicate all but 1% of the damage can be removed. Post-annealing is also indicated for a GaAs cell; but a larger portion of defects remain (10%), partly because the defects are more complex. The continuous annealing method involves operating the cell at a higher temperature than desired from an efficiency standpoint, but the benefit is a reduction in damage incurred. Temperatures of at least 125°C are necessary for removal or prevention of proton damage. GaAs cells are not as sensitive to high temperatures as silicon cells and, therefore, are candidates for this annealing approach. Use of a CR = 2 design can result in array temperatures of 125°C. The GaAs continuous case indicated as most likely (i.e., less data extrapolation) shows 5% damage remaining; and the best possible case (highest uncertainty), 1% damage remaining.

4.4.2 System Options and Comparison

4.4.2.1 System Options

Three basic accelerated technology system options were considered:

1. Option 1: Silicon array with post-annealing. Both a 75-50-50 μm array (Option 1A) and a 300-50-250 μm array (Option 1B) were considered to determine if annealing would make the use of lightweight arrays more beneficial.
2. Option 2: GaAs array with post-annealing (Option 2A) and continuous annealing (Option 2B).
3. Option 3: Most optimistic GaAs EOTV. This option investigated the more optimistic projections in technology and design features through use of higher performance cells, direct drive (minimum power processing), high beam current, and improved continuous annealing.

Principal performance and cost features of these options are shown in table 4.4-1. Differences from the normal growth technology EOTV are emphasized. All options continued to use 50-cm argon ion thrusters. Option 1A, using a lightweight silicon cell array, provides a lower specific mass for the power generation system and annealing improves the power ratio. Option 1B also uses silicon cells, and both heavy shielding and annealing further improve the power ratio to 0.70. Option 2A, using higher performance GaAs cells and annealing, has improved power output and power ratio but a higher array specific mass. Use of a CR = 2 design, as in Option 2B, considerably improves the power

Table 4.4-1. Performance and Cost Characteristics of Accelerated Technology EOTV's

PARAMETER	NORM. TECH.	ACCELERATED TECHNOLOGY				
		OPT. 1A	OPT. 1B	OPT. 2A	OPT. 2B	OPT. 3
● CELL TYPE	SILICON	✓	✓	GaAs	GaAs	GaAs
● BLANKET (μm) (COVER-CELL-SUBST)	300-50-250	75-50-50	✓	75-50-50	75-50-50	75-50-50
● CONCEN. RATIO	1	✓	✓	✓	2	2
● CELL EFF (AMO 25°C)	16	✓	✓	18	18	20
● POWER OUTPUT (W/M ²) ¹	179	✓	✓	210	342	380
● PWR GEN (KG/KW) ³	10.4	4.0	10.4	4.3	3.7	3.7
● ANNEALING	NO	POST	POST	POST	CONTINUOUS	CONTINUOUS
● DAMAGE REMAINING EACH TRIP ² (% OF TRIP FLUENCE)	100	1	1	10	5	1
● P/P _o AFTER 10th TRIP (%)	45	49	70	53	63	73
● PWR PROCESS (KG/KW)	3.1	✓	✓	✓	✓	1.5
● NORMALIZE COST PER CELL (SAME QTY)	1.0	✓	✓	1.5	1.5	1.5

- ¹ BOL REFLECTING ALL EXPECTED LOSSES EXCEPT RADIATION
- ² 180 DAYS UP/45 DAYS DOWN
- ✓ SAME AS NORMAL TECH.

- ³ SOLAR ARRAY, STRUCTURE & DISTRIBUTION

output and more effective annealing improves the power ratio. Option 3 is the most optimistic design. This system includes a 20% cell and more effective annealing resulting in the highest power ratio; a direct drive, which obtains power directly from the array and supplies it to the thruster screens to reduce the amount of power processing; and a thruster design approach that allows use of a 20A beam current for more thrust for a given Isp while still satisfying burn-life constraints.

4.4.2.2 Comparison and Selection

Cost comparisons of accelerated technology options and the normal growth EOTV are presented in figure 4.4-2. All options reflect trip times of 180 days up and an Isp of 6000 sec. All options offer considerable improvements over the normal growth vehicle, primarily from smaller solar arrays which reduce the amount of electric propulsion.

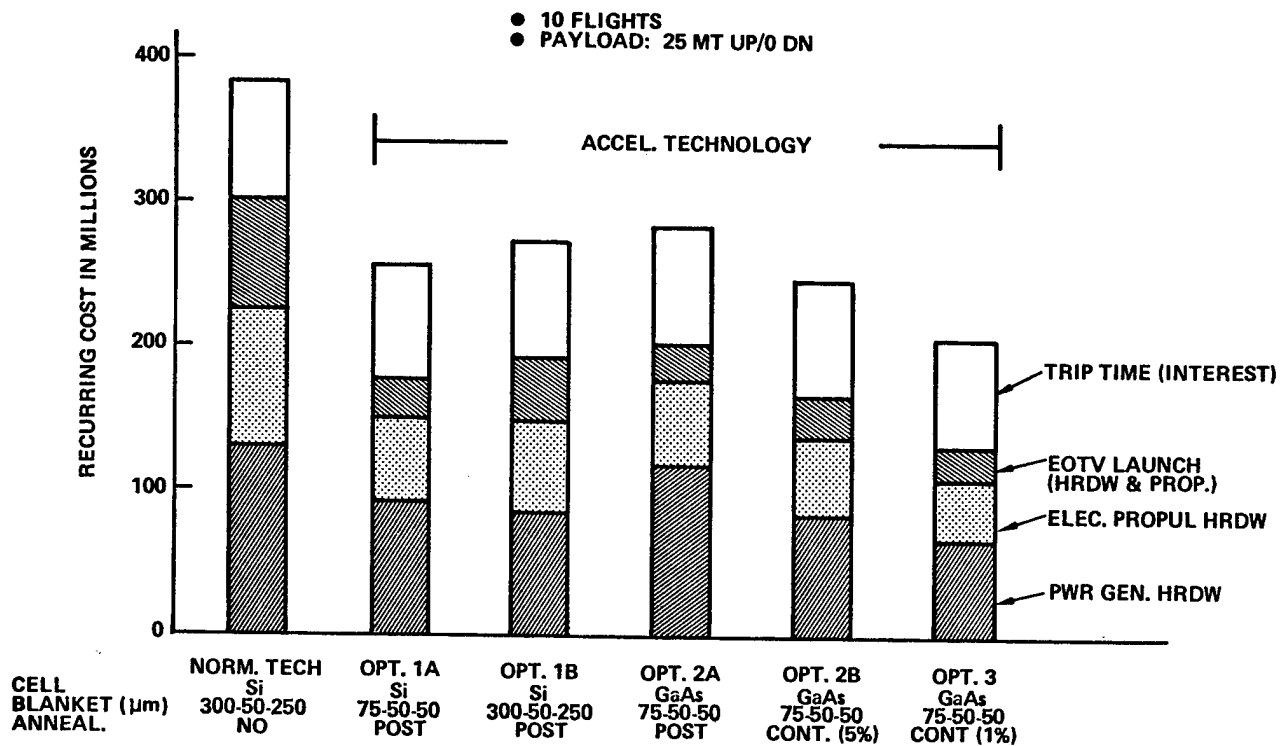
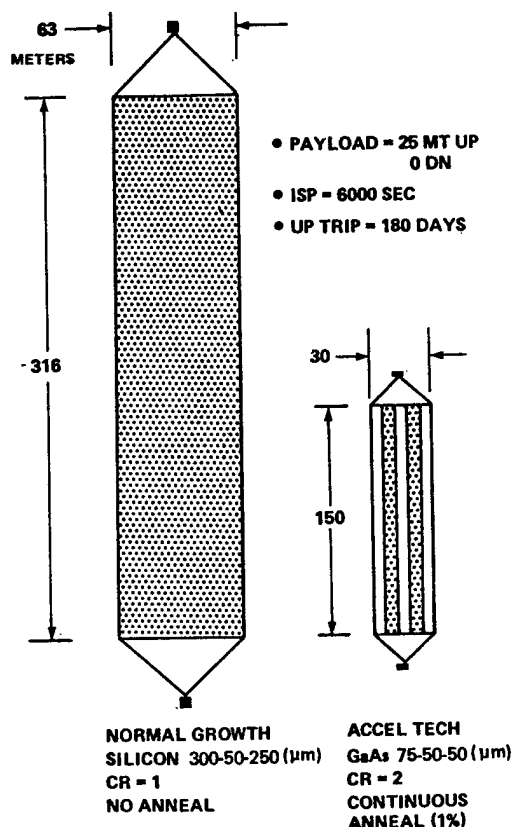

Figure 4.4-2. EOTV Cost Comparison—Accelerated Versus Normal Technology

In the case of the silicon options, the lightweight array with annealing provides an advantage over the heavy shielded option due to lower launch costs. The small advantage (delta 5%) in annealing effectiveness of the continuous annealing GaAs EOTV (Option 2B) over the post-annealable GaAs EOTV (Option 2A) escalated to approximately 14% in terms of cost, which indicates the leverage for continuous annealing if it is technically feasible. The GaAs Option 2B, however, provides only a small cost margin over the lightweight silicon option because its higher cost per unit area offsets its smaller area. Option 3, which had the most optimistic performance assumptions, resulted in the least-cost system.

A comparison of the least-cost accelerated technology vehicle and the normal growth EOTV is shown in figure 4.4-3. This comparison involves the most optimistic GaAs EOTV (Option 3) and the nonannealable heavy shielded silicon EOTV. Advantages associated with the accelerated system are primarily the result of annealing. The BOL power is reduced by 75%, the array area is only 16% as large, and dry weight is reduced because annealing is more effective than heavy shielding. The average unit cost is reduced 50% but is limited to a certain degree because the GaAs array has a higher cost per square meter. In summary, the advantages of this accelerated technology option



KEY CHARACTERISTICS

	NORMAL	ACCEL
• BOL POWER (KW)	3600	930
• AREA (10 ³ SQ M)	19.6	2.4 (ACTIVE)
• DRY WT (MT)	51.0	7.8
• PROP/FLT (MT)	14.5	4.8

AVG UNIT COST (\$ MILLIONS)

	NORMAL	ACCEL
POWER GEN	146	72
ELECT PROPULSION	81	36
AVIONICS	10	10
OTHER	6	6
FLT HRDW	243	122
ASSY & C/O	36	18
SUPPORT	82	39
TOTAL	361	179

Figure 4.4-3. Accelerated Versus Normal Technology—Electric OTV

appear significant enough to offset, temporarily, the concerns associated with some of its optimistic design and performance features. Consequently, Option 3 will be used to reassess a mixed OTV fleet versus an all-chemical OTV fleet.

4.4.3 OTV Fleet Cost Comparison

The cost comparison involves two OTV fleet options: (1) a mixed fleet of the selected accelerated technology EOTV for trip time insensitive payloads and a normal growth technology LO₂/LH₂ OTV for high-priority cargo, and (2) a normal growth LO₂/LH₂ OTV for all payloads. The number of flights for each vehicle is the same as defined in the normal growth comparison. The cost comparison of the two options for the total mission model is shown in figure 4.4-4. The mixed fleet using an accelerated technology EOTV shows a reduction of \$2B or 14% compared to the mixed fleet using the normal growth EOTV. This reduction is a result of a near 50% reduction in EOTV DDT&E and production costs and a 10% lower SDV launch cost. When compared to the all-chemical fleet, however, the cost of the best mixed fleet is still 5% higher.

As a sensitivity, a 50% increase in launch cost was considered to determine the benefits to the higher performance EOTV operating in a mixed fleet. In this case the cost

of the two OTV fleets was essentially equal, although some cost factors have not been taken into consideration.

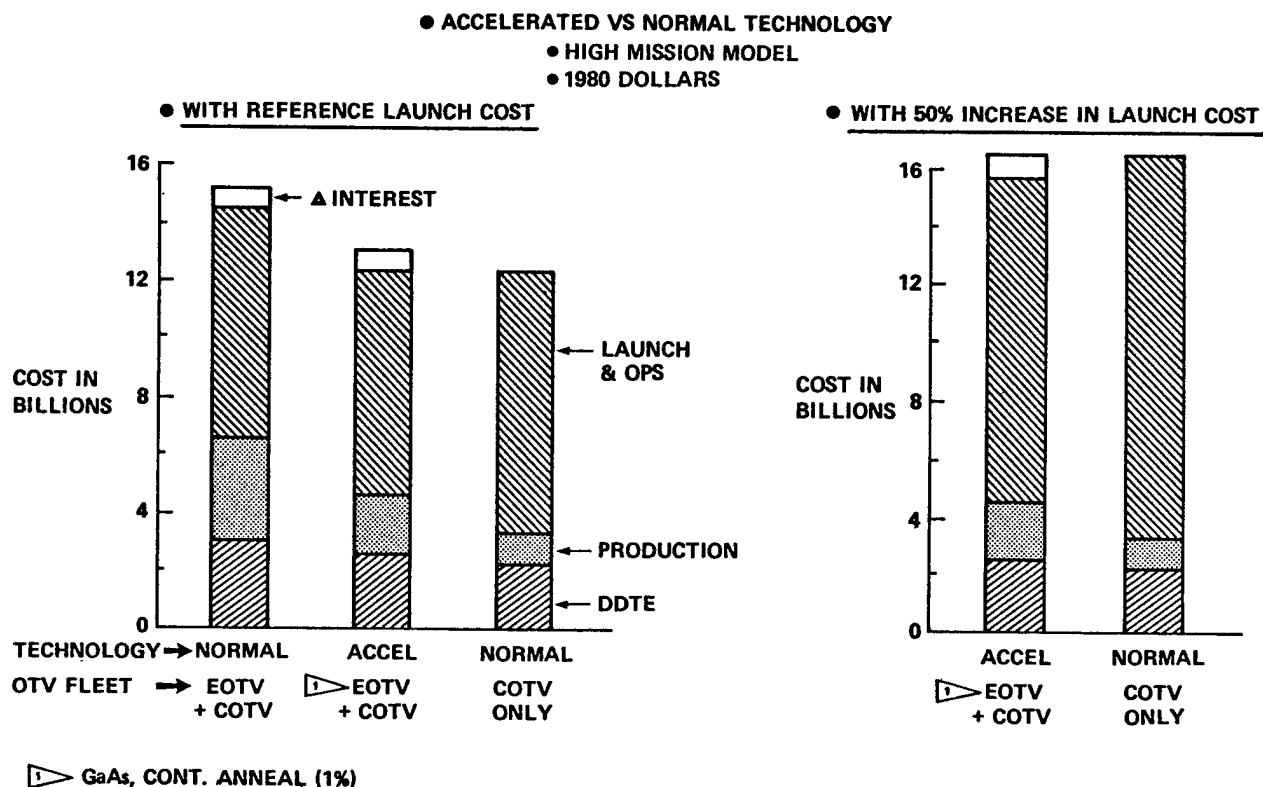

Figure 4.4-4. Transportation Cost Summary—Mixed Versus All-Chemical Fleets

These include: (1) research and development (R&D) to achieve the design and performance features identified for the most optimistic vehicle, (2) construction costs (SOC users charge), and (3) cost impact on EOTV payloads requiring radiation protection.

In summary, the potential additions to the cost comparison tend to further substantiate the belief that an all-chemical OTV fleet provides the least transportation cost within the constraints of the analysis.

4.4.4 EOTV Use for GEO Refueling

Consideration was given to using EOTV's to deliver propellant to GEO base storage facilities for use by LO₂/LH₂ OTV's for their return to LEO. This would permit sizing the LO₂/LH₂ vehicles for one-way trips, resulting in less propellant needed for the up leg of the trip. This did not prove cost effective, however, for the following reasons:

1. The selected LO₂/LH₂ concept uses aeroassist for return, which already reduces the amount of propellant needed relative to an all-propulsive vehicle.

2. The mission model did not include enough round-trip payloads to benefit from the GEO refueling concept.

4.5 FINDINGS

Principal findings from the comparison of electric and chemical OTV's apply only in terms of the guidelines and assumptions used; the most significant of which were that application was for cargo missions between LEO and GEO, and comparisons were performed in context of total transportation system requirements. These findings are:

1. **An all-LO₂/LH₂ OTV fleet was a clear winner.** Mixed fleets involving EOTV's did not provide cost or operational benefits. This was true with normal growth EOTV's (+24% LCC) and accelerated technology EOTV's (+5% LCC) for GEO payload mission models up to 300 t/yr. Launch cost would have to increase over 50% for the fleet cost to be the same.
2. **Use of EOTV's for GEO refueling of chemical OTV's does not provide a cost benefit related to LEO refueling.**
3. **Accelerated technology had a payoff for EOTV's.** The most significant improvement was annealing which reduced EOTV LCC by 50%. Annealing effectiveness is still an open issue.
4. **Annealable silicon and GaAs arrays had comparable costs.** Lower performance and higher radiation sensitivity were offset by annealing and lower costs per unit area.
5. **Solar cell cost prediction was speculative.** This applies to large quantities (5000 to 10 000 m²/yr). GaAs cell costs had greater uncertainty than silicon.
6. **EOTV use had major uncertainties.** Key concerns included design life as affected by radiation and payload exposure to radiation.

4.6 RECOMMENDATIONS

The recommendations below result from the EOTV definition and OTV fleet comparison.

1. **Give no further consideration to photovoltaic EOTV's for GEO cargo delivery.** Silicon or GaAs EOTV's with low concentration ratios are not cost effective. An exception would be if there were some major deviation in the assumed performance or costing of these systems.

2. **Focus on improving performance and operational capabilities of a space-based reusable LO₂/LH₂ OTV.** Mission models of the size investigated could justify accelerated technology refueling concepts and, potentially, LF₂/LH₂ systems.
3. **Focus any further EOTV technology on radiation and cost data.**
 - a. Conduct extensive radiation and annealing analyses including:
 - (1) Development of radiation tests that use rates related to cost-effective trip times (180 days).
 - (2) Multiple annealings of cells with radiation degradation comparable to that received in one round trip.
 - (3) Development of a common presentation format.
 - b. Obtain radiation and cost data for advanced cells identified by this study but not included in the analysis.
 - c. Assess design life limits due to multiple trips between LEO and GEO.
 - d. Develop cost data associated with large quantities of solar cells (5000 to 10 000 m²/yr).
 - e. Improve cost predictions for thin (50 μm) GaAs cells.

5.0 REFERENCES

1. Boeing Aerospace Company: Orbital Transfer Vehicle Concept Definition Study. Final Report. NASA CR's 161783 to 161788, 1980.
2. Caluori, V. A.; Conrad, R. T.; and Jenkins, J. C.: Technology Requirements for Future Earth to Geosynchronous Orbit Transportation Systems. NASA CR-3265, 1980.
3. Andrews, D. G. et al: Optimization of Aerobraked Orbital Transfer Vehicles. AIAA-81-1126, AIAA 16th Thermophysics Conference, June 1981.
4. Boeing Aerospace Company: Shuttle Derivative Vehicle Study - Operations, Systems and Facilities. Final Report. NASA CR's 150528 to 150531 and 150538, 1977.