

345050

JPRS-UMM-84-019

30 October 1984

19980825 166

USSR Report

MACHINE TOOLS AND METALWORKING EQUIPMENT

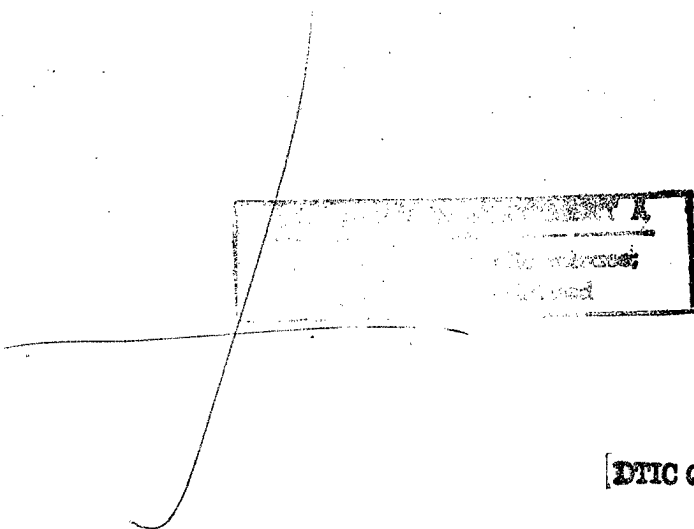

DTIC QUALITY INSPECTED 2

FBIS FOREIGN BROADCAST INFORMATION SERVICE

REPRODUCED BY
NATIONAL TECHNICAL
INFORMATION SERVICE
U.S. DEPARTMENT OF COMMERCE
SPRINGFIELD, VA. 22161

6
43
A03

NOTE

JPRS publications contain information primarily from foreign newspapers, periodicals and books, but also from news agency transmissions and broadcasts. Materials from foreign-language sources are translated; those from English-language sources are transcribed or reprinted, with the original phrasing and other characteristics retained.

Headlines, editorial reports, and material enclosed in brackets [] are supplied by JPRS. Processing indicators such as [Text] or [Excerpt] in the first line of each item, or following the last line of a brief, indicate how the original information was processed. Where no processing indicator is given, the information was summarized or extracted.

Unfamiliar names rendered phonetically or transliterated are enclosed in parentheses. Words or names preceded by a question mark and enclosed in parentheses were not clear in the original but have been supplied as appropriate in context. Other unattributed parenthetical notes within the body of an item originate with the source. Times within items are as given by source.

The contents of this publication in no way represent the policies, views or attitudes of the U.S. Government.

PROCUREMENT OF PUBLICATIONS

JPRS publications may be ordered from the National Technical Information Service (NTIS), Springfield, Virginia 22161. In ordering, it is recommended that the JPRS number, title, date and author, if applicable, of publication be cited.

Current JPRS publications are announced in Government Reports Announcements issued semimonthly by the NTIS, and are listed in the Monthly Catalog of U.S. Government Publications issued by the Superintendent of Documents, U.S. Government Printing Office, Washington, D.C. 20402.

Correspondence pertaining to matters other than procurement may be addressed to Joint Publications Research Service, 1000 North Glebe Road, Arlington, Virginia 22201.

Soviet books and journal articles displaying a copyright notice are reproduced and sold by NTIS with permission of the copyright agency of the Soviet Union. Permission for further reproduction must be obtained from copyright owner.

30 October 1984

USSR REPORT

MACHINE TOOLS AND METALWORKING EQUIPMENT

CONTENTS

INDUSTRY PLANNING AND ECONOMICS

Industry Minister Bal'mont on Modernization (B. V. Bal'mont; EKONOMICHESKAYA GAZETA, No 40, Oct 84).....	1
Plan Figures for Soviet Machine Tool Industry (EKONOMICHESKAYA GAZETA, No 40, Oct 84).....	6
Minpribor Enterprises Meet Output Targets (Yu. Ivanov; EKONOMICHESKAYA GAZETA, No 37, Sep 84).....	8
Briefs	
Leading Machine Tool Associations	9
Lagging Machine Tool Producers	9

METAL-CUTTING AND METAL-FORMING MACHINE TOOLS

Report on High-Precision Jig-Boring Machines (L. M. Kordysh; SOVIET EXPORT, No 3, 1984).....	11
---	----

OTHER METALWORKING EQUIPMENT

Electro-Spark Case-Hardening of Contoured Surfaces (V..L. Andreyev, et al.; MASHINOSTROITEL' No 4, Apr 84).....	15
Briefs	
Heavy-Lift Loading Platform	18
Magnetic Abrasion Polishing	18
New Heavy Duty Press	18
Precision Parts Casting Machine	19

ROBOTICS

Growth, Future of Soviet Robotics Sector Analyzed (Viktor Gerasimov, Nikolay Petrov; ZNAMYA, No 8, Aug 84)....	20
---	----

INDUSTRY PLANNING AND ECONOMICS

INDUSTRY MINISTER BAL'MONT ON MODERNIZATION

Moscow EKONOMICHESKAYA GAZETA in Russian No 40, Oct 84 p 6

[Article by USSR Minister of the Machine Tool and Tool Building Industry B. V. Bal'mont: "What Is New in Machine Tool Building"; passages rendered in all capital letters printed in boldface in source]

[Text] The further development of the production, scientific and technical potential of machine building and the increase of its efficiency, which is an important factor of intensification, in many ways are governed by the level of development of the domestic machine tool and tool building industry. The Ministry of the Machine Tool and Tool Building Industry is supplying the sectors, which produce more than a fourth of the total output of industry, with modern tools of labor.

Since the beginning of the current five-year plan we have been carrying out the large-scale changeover of production to the output mainly of machine tools and machines with numerical control, robots and robotized complexes and versatile production modules. The deliveries of automatic and semi-automatic lines and transfer machines have been increased. The list of our products is being updated more rapidly than before. This year the production of highly productive NC machine tools as compared with 1980 is being increased by 1.8-fold, including "processing centers" by 2.5-fold and automatic transfer lines by 1.5-fold. The production of automated forging and pressing equipment is increasing: automatic lines--1.4-fold, NC machines--1.7-fold, general-purpose machines, which are equipped with means of automation, and complexes--more than 2-fold. At the same time the share of equipment with manual control is decreasing.

THE RESULTS OF 3 YEARS AND 8 MONTHS SHOW THAT THE GROWTH RATE OF THE OUTPUT OF AUTOMATED EQUIPMENT, WHICH WAS PLANNED FOR THE FIVE-YEAR PLAN, IS BEING MAINTAINED.

At the present stage the technical improvement of the products of the sector is inseparably connected with the more extensive use of systems of automatic control, means of computer technology and diagnostics and the latest electric drives and automatic electric equipment and with the concentration in one unit of various technological processes. NC lathes, milling machines, drilling machines and other machine tools are being equipped with microprocessor

devices with a main permanent memory, in which a large number of standard processing cycles and ready-made control programs are stored. The proportion of multi-operation machine tools with the automatic change of the tool--"processing centers"--and highly efficient modified versions, which are being developed on their basis--so-called versatile automated production modules--is increasing rapidly.

The multipurpose machine tool with a 12-place storage unit of accessory tables, which has been assimilated by the Ivanovo Machine Tool Building Production Association imeni 50-letiya SSSR, can serve as an example of such a module. It is designed for the highly productive and precision machining of especially complicated base members. The drilling, trueing, reaming and boring of precision holes, milling, threading, as well as turning are carried out in one session. The module creates the possibility of multiple-machine attendance and is being incorporated as a fundamental part in versatile production systems (GPS's).

Schematically the versatile production system consists of several standardized modules, an automated storehouse of blanks and tools and a transportation system, which are controlled by a single electronic "brain." The computer synchronizes the handling of parts, the delivery of tools and the operation of machine tools and robots. Moreover, each module is equipped with its own microcomputer, the memory of which holds a supply of programs. Their change takes place at the signal of the main computer, and the machine tool is instantaneously changed over for the machining of a different part. Such systems ensure the minimum involvement of man in the technological process.

It should be noted that the efficient use of such equipment requires the carrying out of the comprehensive preparation of production and the appropriate organization of service. This gives rise to the need for the especially careful organization of the steady supply of the versatile production system with advanced types of blanks. Greater demands are made on the durability of the cutting tool and the quality of the operating means of monitoring.

It is customary to settle in advance the questions of the organization of production and the service of the versatile production systems. I want especially to direct the attention of planning organizations and enterprises to this aspect of the matter.

OUR SECTOR IS CALLED UPON TO BECOME THE BASIC SUPPLIER OF AUTOMATED METALWORKING EQUIPMENT FOR VERSATILE PRODUCTION SYSTEMS.

More than 70 percent of the versatile production modules will be produced by our plants. The pursuit of a unified technical policy in the area of versatile automated production systems has also been assigned to the Ministry of the Machine Tool and Tool Building Industry.

Versatile systems, as a rule, are most efficient in case of the production of small series, when frequent readjustment is necessary. As to enterprises with a large-series and mass nature of production, automatic and semi-automatic lines and transfer and special machines are required for them.

Considerable experience has been gained here in the development of such equipment, which is operating successfully at the Kama Motor Vehicle Plant, the Volga Motor Vehicle Plant, the Moscow Motor Vehicle Plant imeni Likhachev and many other machine building giants. According to all the parameters domestic automatic lines are at the present world technical level.

Hundreds of new sets have to be produced in the shortest possible time. During 1984-1985 alone more than 750 transfer lines will be produced, including for the production of grain combines of the Don family and new models of the Moskvich and Zaporozhets cars. The orders of the Gorkiy Motor Vehicle Plant and the Moscow Motor Vehicle Plant imeni Likhachev are next.

Of those introduced this year the system of lines for the complete machining of the cylinder head of a tractor engine should especially be noted. It was designed at the affiliate of the Moscow Special Design Bureau of Automatic Lines and Transfer Machines. It was produced at the capital's Stankoagregat Plant imeni 60-letiya SSSR.

The system consists of six lines, which are united into a single complex by the storage units of parts and the transport and other devices, which operate in automatic mode. In all 3 operators and 6 adjusters attend the entire complex made up of 36 transfer machines, which have 372 spindles and perform the operations of milling, drilling, hole trueing, reaming, boring and threading. The productivity is 40 parts an hour. Various devices for the monitoring of the size of the allowances of the billet and the adjustment of all types of tools outside the machine tool and counters of the cycles for giving the adjuster a signal on the time of the planned replacement of the cutting tool are used. The economic impact of the introduction of the system exceeds 1 million rubles.

As experience shows, great effectiveness is achieved from the use of automatic rotary and rotary conveyor lines, which are being employed in a number of sectors of machine building and the chemical and food industries. Such lines, which are characterized by the precision, stability and continuity of the technological processes, make it possible to increase sharply the level of the intensification of industrial production. Their use promotes the significant increase of labor productivity, the decrease of production areas, the freeing of a large number of personnel and the improvement of working conditions.

On the instructions of the Politburo of the CPSU Central Committee, which has examined the question of the introduction of rotary lines in the national economy, the appropriate ministries and departments will be enlisted in the development and use of this type of advanced equipment. The scientific research and design work in the area of the development of rotary lines for the machining of parts has been stepped up in our sector.

THE FUNCTIONS OF THE WORKER ARE NOW ACQUIRING A QUALITATIVELY DIFFERENT NATURE. MODERN EQUIPMENT REQUIRES THE SPECIALIZED TRAINING OF PERSONNEL.

Such work is now being performed at a number of vocational and technical schools and tekhnikums. However, the scale is obviously inadequate. For the

present the supply of educational institutions with the necessary equipment is also poor. I would like to draw the attention of the State Committee for Vocational and Technical Education, the machine building ministries and the USSR Ministry of Higher and Secondary Specialized Education to the solution of this problem. It is noteworthy that the Leningraders have formed the training of skilled personnel for work with modern, first of all computer, technology into one of the most important sections of the Intensification-90 Territorial-Sectorial Program.

The training of technicians in the specialty "The Operation and Adjustment of NC Machine Tools" has been organized in our sector. Moreover, NC machine tools are being studied in such specialties as "The Machining of Metals," "Metal-Cutting Machine Tools and Automatic Lines" and several others.

The assurance of a two- and three-shift "unattended" mode of operation of versatile production modules and versatile production systems involves the lengthening of the continuous trouble-free functioning of all the components of the equipment in the automatic cycle without the direct involvement of an attendant. The multiple increase of the reliability of all the components of versatile production systems is one of the most important practical tasks, which is now being worked on by the subdivisions of our ministry in cooperation with the organizations of the Ministry of Instrument Making, Automation Equipment and Control Systems, the Ministry of the Electronics Industry and the Ministry of the Electrical Equipment Industry.

BEING IN THE FRONT LINE OF THE DRIVE FOR THE ACCELERATION OF SCIENTIFIC AND TECHNICAL PROGRESS AND THE INCREASE OF THE INTENSIFICATION OF PRODUCTION, THE MACHINE TOOL BUILDERS ARE TAKING VIGOROUS STEPS FOR THE INCREASE OF THE EFFICIENCY OF THEIR WORK.

In 1984 during all the months the sector as a whole has been steadily fulfilling the plan assignments. A higher growth rate of the output as compared with the corresponding period of 1983 has been achieved. The level of fulfillment of the obligations on deliveries has improved noticeably. During the past period of the year the sale of products with allowance made for this factor came to 99 percent. However, the missing percent indicates that not all of our enterprises and all-union industrial associations have put the necessary reserves to use. The Collegium of the Ministry of the Machine Tool and Tool Building Industry is keeping the discipline of deliveries under special control and is holding its violators strictly accountable.

Since the beginning of the year more than 200 new items have been assimilated. The share of products of the highest quality category has reached 45.9 percent.

In 3 years of the five-year plan labor productivity has increased by 19.7 percent with a plan assignment of 16.8 percent. In 8 months of this year it has increased as against the corresponding period of last year by 7.4 percent with a plan assignment of 5.6 percent. An above-plan decrease of the production cost by 0.9 percent has been achieved. The specific expenditures of rolled metal products and cast iron have decreased slightly.

The ultimate effectiveness as a whole could have been better with respect to a number of indicators. Not all of the assignments and measures, which were specified by the sectorial goal programs, were fully accomplished during the past period.

At a number of enterprises there are still significant reserves of the increase of the efficiency of production, scientific and technical activity, the available potential is being used inadequately. The assignments on the increase of the machine shift coefficient are not being fulfilled. The conditions for the development of multiple-machine attendance are being created slowly. The elimination of these and other shortcomings is the most urgent task of the all-union industrial associations and the staff of the ministry.

In the set of measures being implemented in the sector a significant place is being assigned to the development of the specialized centralized production of standardized items for general sectorial and general machine building use. During the current five-year plan the volume of this output will increase by more than 47 percent. The proportion of the centralized production of individual types of standardized items in the total volume of its output in the sector has reached a high level, for example, 92 percent for hydraulic drives and automatic hydraulic equipment. As the result the enterprises, which are the producers of basic products, have been freed completely from the need to have their own sections and shops for the production of standardized items and fasteners, which is contributing to the decrease of expenditures and the increase of labor productivity.

The participation of the sector next year in the large-scale economic experiment, which is aimed at the broadening of the rights of production associations and enterprises in planning and economic operations and at the increase of their responsibility for the end results, will promote the further improvement of the work of machine tool building. Active preparation for work under the new conditions is now under way.

7807
CSO: 1823/68

INDUSTRY PLANNING AND ECONOMICS

PLAN FIGURES FOR SOVIET MACHINE TOOL INDUSTRY

Moscow EKONOMICHESKAYA GAZETA in Russian No 40, Oct 84 p 1

[Article: "What Is New in Machine Tool Building"]

[Text] In the area of machine tool building the 26th party congress posed for the 11th Five-Year Plan the tasks of increasing the productivity of the equipment being produced by 1.3- to 1.6-fold, increasing its reliability and durability and improving the precision of metal-cutting machine tools by not less than 20-30 percent. Particular attention in the decisions of the congress and the five-year plan is devoted to the increase of the production of NC machine tools and automatic lines, including readjustable complexes of metalworking equipment, which are furnished with automatic manipulators.

Among the sectors, which govern the rate of scientific and technical progress, machine tool building is in the front line of the drive for the increase of the intensification of social production, ensuring the renovation and retooling of enterprises of various sectors, and first of all machine building.

In 3 years of the five-year plan the number of mechanized flow lines in industry increased by 7,900, automatic lines--by 3,500. The number of completely mechanized and automated sections, shops and works increased from 91,000 in 1981 to 97,200 in 1983, completely mechanized and automated enterprises--from 6,500 to 6,800.

In accordance with the 1984 plan the production of industrial robots, which should exceed 11,000, is being increased intensively, versatile processing methods are being actively introduced. The production of NC machine tools is being increased as compared with 1983 by nearly 20 percent. The results of January-August show that as a whole these assignments are being fulfilled.

In 8 months 9,000 industrial robots have been produced--36 percent more than during January-August 1983. As compared with the same period last year the production of NC machine tools increased by 21 percent.

USSR Minister of the Machine Tool and Tool Building Industry B. V. Bal'mont tells about the work of the sector in 1984 in an article on page 6.

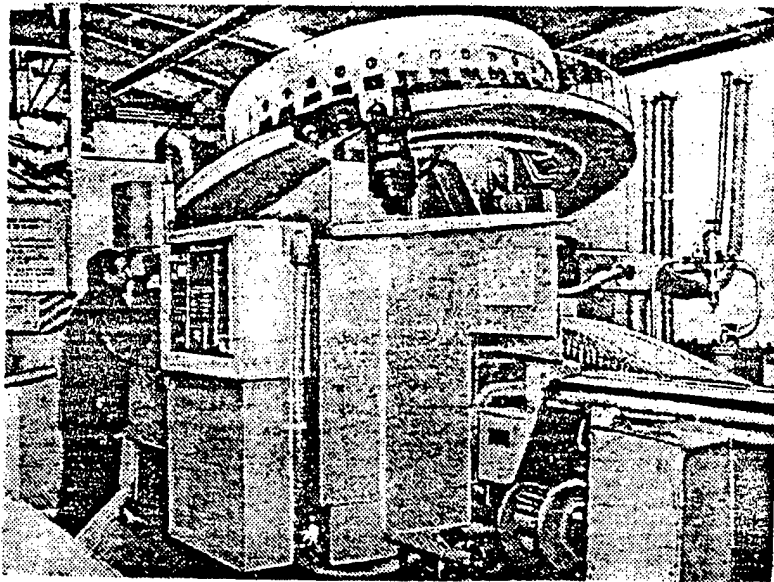

(1) ВЫПУСК МЕТАЛЛОРЕЖУЩИХ
СТАНКОВ С ЧИСЛОВЫМ
ПРОГРАММНЫМ УПРАВЛЕНИЕМ
[тысяч штук]

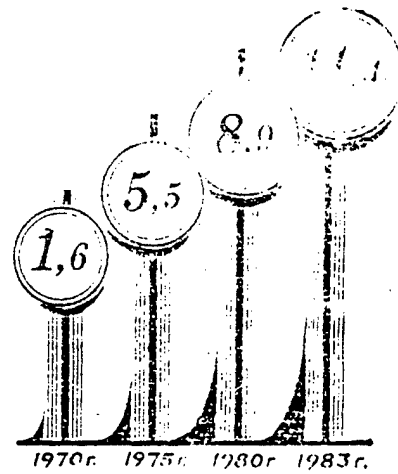

(2) КОЛИЧЕСТВО АВТОМАТИЧЕСКИХ
ЛИНИЙ В ПРОМЫШЛЕННОСТИ
[на 1 июля, тысяч]

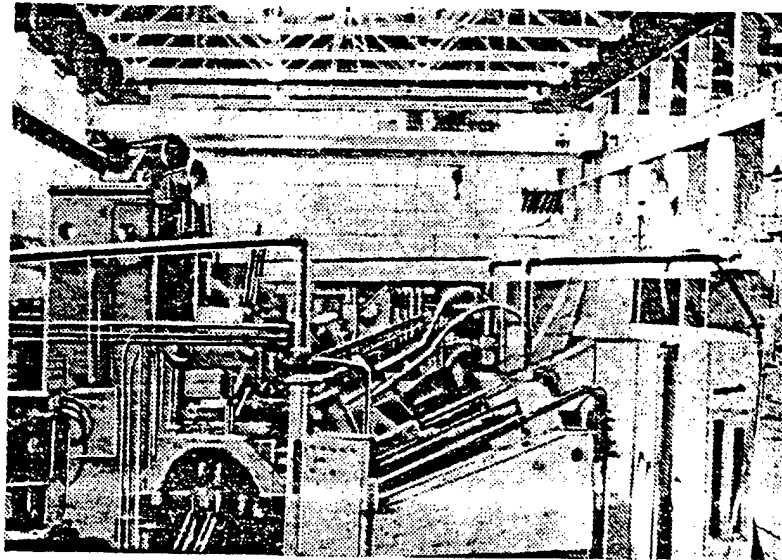
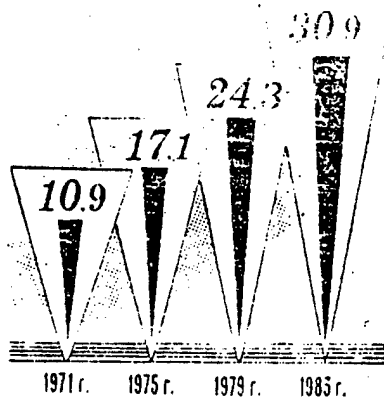

Key:

1. Production of NC metal-cutting machine tools (thousands)
2. Number of automatic lines in industry (on 1 July, thousands)

In the photographs: top--a versatile automated production module--the multi-purpose machine tool with a 12-place storage unit of accessory tables of the Ivanovo Association imeni 50-letiya SSSR; bottom--a system of lines for the complete machining of the cylinder head of a tractor engine of the Moscow Stankoagregat Plant.

7807

CSO: 1823/68

INDUSTRY PLANNING AND ECONOMICS

MINPRIBOR ENTERPRISES MEET OUTPUT TARGETS

Moscow EKONOMICHESKAYA GAZETA in Russian No 37, Sep 84 p 4

[Article by Yu. Ivanov: "In the Rhythm of the Obligations"]

[Text] The enterprises of the Ministry of Instrument Making, Automation Equipment and Control Systems as a whole are successfully fulfilling the socialist obligations which were assumed for 1984. As compared with the same period last year labor productivity has increased in 8 months by 8.2 percent as against 6.5 percent according to the annual assignment.

The entire increase of the production volume (6.2 percent as against the desired 4.6 percent) has been obtained by means of the increase of labor productivity. The preliminary data attest that the additional decrease of the product cost will come to more than 0.5 percent.

The assignment on the output of products, which have been certified for the highest quality category, has been fulfilled.

In 8 months of this year the plan of the sale of products with allowance made for deliveries has been fulfilled by 99.1 percent (during the same period last year--98.9 percent). With respect to the corresponding period last year the number of enterprises, which have not coped with this indicator, decreased from 105 to 85, while the amount of undelivered products decreased from 41.7 million rubles to 34.5 million rubles.

The brigade form of the organization and stimulation of labor is being improved and developed. At present 70.1 percent of the workers are united in brigades, of them 93.9 percent are paid in accordance with the end results of labor (at the beginning of the year they were respectively 69 and 93.2 percent). The share of cost accounting brigades has increased since the beginning of the year by 3.2 percent, having come to 19.2 percent.

As the tentative results of January-August show, the collectives of the Moscow Manometr Association, the Cheboksary Elektropribor Association and the Saransk Instrument Making Plant are in the lead of the socialist competition. At the same time a number of enterprises are lagging chronically. For example, the Tallinn Prompribor Association and the Leningrad Vibrator Association are operating unsatisfactorily.

7807

CSO: 1823/68

BRIEFS

LEADING MACHINE TOOL ASSOCIATIONS--The [Stankostroitel'nyy zavod imeni Sergo Ordzhonikidze] Association (General Director N. Chikerev) produced in excess of the plan of January-August seven highly productive metal-cutting machine tools. As compared with the same period of last year labor productivity increased by 14.85 percent with an assignment of 12.94 percent. The product cost was additionally reduced by 0.8 percent. The entire increase of the production volume was obtained by the increase of labor productivity. The share of products of the highest quality category came to 77.5 percent as against 74.4 percent according to the plan. [Text] [Moscow EKONOMICHESKAYA GAZETA in Russian No 40, Oct 84 p 6] Having exceeded the assignments of 3 years of the five-year plan on the growth rate of commodity production and labor productivity, the [Kiev] Machine Tool Building Association (General Director V. Kal'chenko) is successfully coping with the higher socialist obligations of this year. In 8 months nine highly efficient multiple-spindle automatic lathes were produced in excess of the plan. All the machine tool products are being produced with the State Emblem of Quality. As compared with January-August of last year labor productivity increased by 7.23 percent as against 5.93 percent according to the assignment. The product cost was additionally reduced by 2.57 percent. [Text] [Moscow EKONOMICHESKAYA GAZETA in Russian No 40, Oct 84 p 6] In 8 months the [Ryazan] Machine Tool Building Association (General Director V. Papanov) shipped to clients in excess of the plan 16 NC machine tools. The obligations on deliveries in conformity with orders and contracts are being completely met. With an assignment of 5 percent labor productivity increased as compared with the same period of last year by 7.1 percent. The product cost was additionally reduced by 0.5 percent. The entire increase of the production volume was achieved by the increase of labor productivity. [Text] [Moscow EKONOMICHESKAYA GAZETA in Russian No 40, Oct 84 p 6] 7807

LAGGING MACHINE TOOL PRODUCERS--The Novosibirsk Tyazhstankogidropress Association (General Director V. Aranovskiy) in 8 months failed to produce eight large metal-cutting machine tools. A decrease of labor productivity was permitted. The product cost increased by 3.35 percent. The volume of product sales with allowance made for the meeting of the obligations on deliveries came to only 72.2 percent. The lag of the association is due mainly to shortcomings in the organization and technical preparation of production and the unsatisfactory work on the attachment and the decrease of the turnover of personnel. The shift coefficient of the basic equipment at the enterprise

comes to only 1.03. [Text] [Moscow EKONOMICHEKAYA GAZETA in Russian No 40, Oct 84 p 6] The [Troitsk Machine Tool] Plant (Director G. Kolgan), which produces equipment for advanced electrophysical methods of machining, failed to produce during the past period 122 machine tools. The plan on commodity production was fulfilled by only 96 percent. A decrease of labor productivity and an increase of the product cost were permitted. The plant needs to increase significantly the technical and organizational level of production. [Text] [Moscow EKONOMICHEKAYA GAZETA in Russian No 40, Oct 84 p 6] 7807

CSO: 1823/68

REPORT ON HIGH-PRECISION JIG-BORING MACHINES

Moscow SOVIET EXPORT in English No 3 (150), 1984 pp 40-41

[Article by L. M. Kordysh, Cand. Sc. (Tech.), Head of Laboratory, Experimental R&D Machine-Tool Institute (ENIMS)]

[Text] The Soviet machine-tool industry produces a line of jig-boring machines with a table width from 250 to 1,400mm. The actual makers of these machines are Machine-Tool Building Amalgamations in Kaunas, Kuibyshev, and Leningrad, and the Moscow Jig-Boring Machine Factory (MZKRS). Products from these enterprises exported by STANKOIMPORT are successfully operated in many countries throughout the world.

Jig borers from the above line provide for machining parts to the most exacting geometric form and positional specifications, the operations including drilling, tapping, milling, and various boring jobs. The use of cutting tools made from superhard materials permits machining hardened parts. High-precision universal index tables make it possible to machine parts on all sides and at any angle.

Thanks to digital readout and coordinates presetting devices, machine members can be brought into position automatically and with a high accuracy. Projection-screen indicating devices, which are simpler in design and more reliable in operation, may be used in place of digital readout.

If necessary, the jig borers can be used as inspection and layout equipment for parts processed on machine tools of standard accuracy.

The jig-boring machines with a table width of 250 to 630mm have a single-column design. Axial motion of the spindle, mounted in a rigid sleeve, is the main feed motion in drilling and boring. An additional setup movement of the spindle head is provided for its optimum positioning with respect to the work-piece.

Double-column jig-boring machines with longitudinally moving table and transversely moving spindle head are built with a table width of 630 to 1,400mm. The spindle head is installed on a cross rail provided with a vertical positioning capability. The spindle is mounted in a sleeve in stiff precision rolling bearings.

At the customer's request, machines with a table 1,000mm wide are supplied with an additional horizontal spindle head, vertically movable on one of the columns, and a work steady-rest.

The version with two spindle heads is a standard one for machines with a 1,400mm wide table.

A stiff gantry-type design, good resistance to vibration, low temperature deformations of main machine units result in a steadily high accuracy of machining large, heavy parts. Digital readout systems with a resolution of 1 μ m allow highly accurate positioning of operative members and even the use of the machine tool as a measuring machine where such is unavailable.

At the customer's request, the jig borers can be equipped with Soviet- or foreign-made numerical control systems. Also available are precision index tables: vertical-axis ones and universal (inclinable) ones, with work surface diameters up to 1,000 and 500mm, respectively. The machines are supplied with sets of work-clamping accessories, precision boring bars, centring devices, marking tools, drill and tap chucks, copying devices, and various cutting tools and arbors.

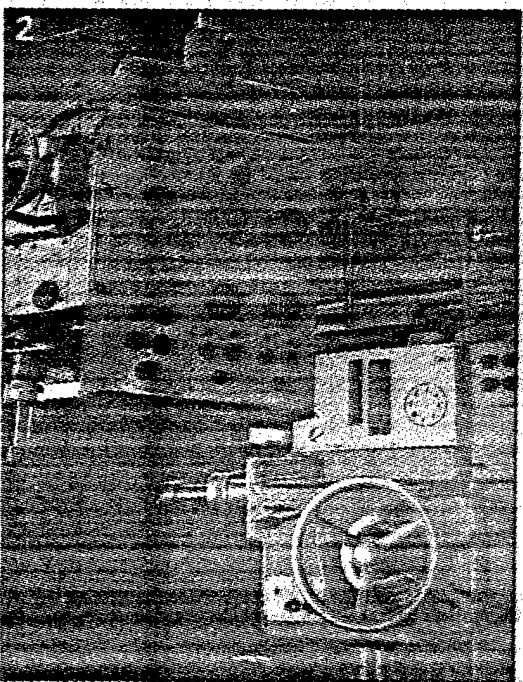

Key:

1. Jig-boring machines are equipped with simple and reliable optical projection devices for cutting tool position adjustment with a minimum scale division of 0.001 mm.
2. The machines with tables 1,400mm wide are made with vertical and horizontal spindle heads.

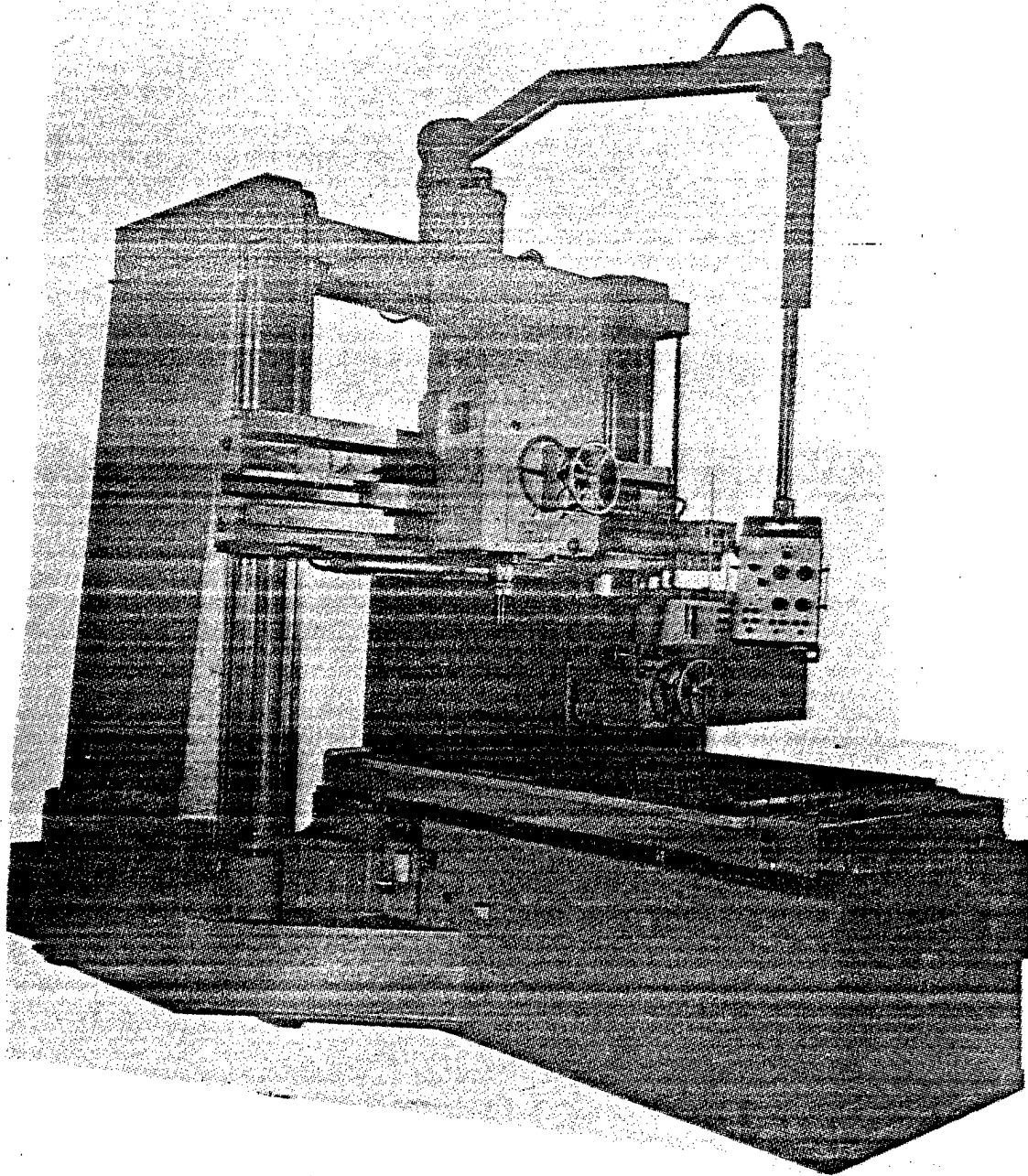

The 2E470A double-column high-precision jig-boring machine produced by Leningrad's Ya. M. Sverdlov Machine-Tool Building Amalgamation

Main Specifications of Single-Column Jig Borers

Characteristic	Model	2421S 2421SFO	2431S	2E440A	2E450 2E450AF11
Table surface, mm		250x360	320x560	400x710	630x1,120
Length of travel, mm:					
longitudinal table		200	400	630	1,000
cross slide		200	250	400	630
spindle		70	125	200	260
spindle head		250	400	270	310
Distance from spindle nose to table, mm		30-350	50-575	160-630	200-770
Main drive motor power, kW		0.55(0.75)	2.5	3.8(2.9)	7.2
Spindle taper		Morse 0	30 (7:24)	40 (7:24)	45 (7:24)
Spindle speed range, rev/min		150-3,000	10-3,000	50-2,000	10-2,000
Drilling capacity, mm		10	20	25	30
Boring capacity, mm		50	125	250	250
Maximum diameter of milling cutter, mm		--	60	125	160
Coordinate positioning accuracy of table, mm		0.002	0.0025	0.003	0.006
Resolution of table position readout, mm		0.001	0.001	0.001	0.001
Out-of-roundness of bored hole, mm		not over 0.001	0.0012	0.002	0.002
Builder		Kaunas MTBA		Kuibyshev MTBA	MZKRS

Main Specifications of Double-Column Jig Borers

Characteristic	Model	2455 2455AF1	2E460A	2B460A	2E470A
Table surface, mm		630x900		1,000x1,600	1,400x2,240
Length of travel, mm:					
table		800		1,400	2,000
spindle head		630		1,000	1,400
spindle		220		360	360
horizontal spindle head		--		720	-- 920
Distance from spindle nose to table surface, mm		80-800		60-1,100	170-1,400
Main drive motor power, kW		3.8		7.5	7.5
Spindle taper		45 (7:24)		50 (7:24)	50 (7:24)
Spindle speed range, rev/min		40-2,000		20-2,000	20-2,000
Drilling capacity, mm		30		40	40
Boring capacity, mm		250		250	250
Maximum diameter of milling cutter, mm		225		160	160
Resolution of table and spindle head position readout, mm		0.001		0.001	0.001
Table and spindle head coordinate positioning accuracy, mm		0.004		0.005	0.007
Out-of-roundness of bored hole, mm, not over		0.002		0.002	0.002
Builder		Kuibyshev MTBA		Leningrad MTBA	

ELECTRO-SPARK CASE-HARDENING OF CONTOURED SURFACES

Moscow MASHINOSTROITEL' in Russian No 4, Apr 84 pp 26-2

[Article by V. L. Andreyev, candidate of technical sciences, V. I. Kerevyenko and N. I. Beda: "Electro-Spark Case-Hardening of Rolls"]

[Text] Electro-spark case hardening of surfaces of parts (austenitic steel 70010) at currents $I = 270...300$ amperes and voltage $V = 32$ volts and depositing the VK8 alloy obtains a protective coating 0.3 to 0.45mm thick and forming a mat-finish of the macrocontour with evenly distributed microprojections and microdepressions with a roughness of $R_z = 180...320$ micrometers.

This was the basis for electro-spark case hardening of rolls for periodic rolling (weight of roll 2.5 tons, material 40Kh steel with surface hardening to a depth of 2 to 3mm and hardness of HRC 34 to 38) and blooming mill rolls (weight of roll 11 tons, material 50 Kh steel with thermal treatment to HRC 32-36), which are subjected to intensive wear in operation and fail comparatively rapidly. A mechanized, electro-spark technology was developed for case-hardening the working surfaces of large-size products to increase their service life.

The electro-spark case-hardening of rolls for periodic rolling was performed on a modernized model 163 turning-thread cutting machine tool. Roll 2 (Fig. 1) was installed and secured at one end in chuck 1 of the machine tool, while the other end was held by the center of tailstock 7.

The electro-spark case-hardening of the surface was done by rotating multi-electrode head 6, whose shaft was located in bearings in frame 4. Worm gear 3 was secured on the left end of the shaft rotated by electric motor 5 ($N = 1.5$ kw, $n = 1440$ rev/min) through a worm mounted on its shaft.

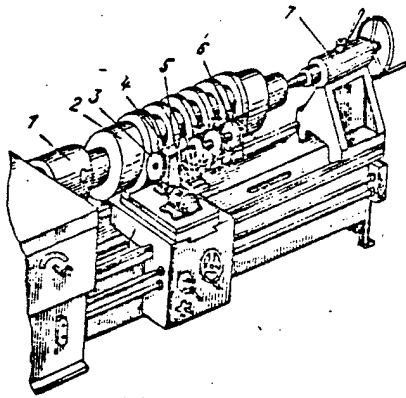

Fig. 1

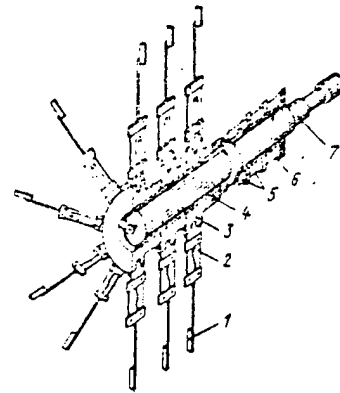

Fig. 2

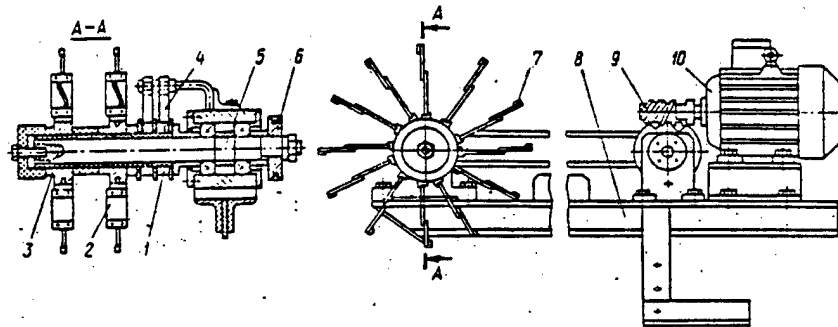

Fig. 3

Shaft 7 (Fig. 2) of the multi-electrode rotating head is insulated from disks 3 mounted on it by textolite bushings 4 and 6. Viscoelastic components 2 (of rubberized cloth) with electrodes 1 are secured to the disks. Collector rings 5 are secured to the right side of the disks. The current is carried to the electrodes of the head to each disk by flexible conductors.

When case-hardening, the roll revolution frequency is $n_1 = 4$ rev/min, the revolution frequency of the electrode head $n_2 = 40$ rev/min and longitudinal feed $s = 1.00$ mm/rev.

Electro-spark case-hardening of blooming mill rolls was done on a model 1825A-5 roll turning machine tool. The blooming mill roll was installed and secured like that described previously. However, in view of the considerably weight of the roll, sliding textolite supports were placed under its journals.

A special device secured to the tool holder on the machine tool carriage is used as the tool in electro-spark case-hardening. It consists of frame 8 (Fig. 3) with electric motor 10 ($N = 1.5$ kw, $n = 1440$ rev/min) installed whose rotation through worm and wormwheel 9, pulley and V-belt is transmitted to pulley 6 and shaft 5 of the electrode head. Electrical disks 3, insulated by textolite bushings from the shaft are secured on the left cantilever part of the shaft. Viscoelastic components 2 made of rubberized cloth with electrodes 7 (plate VK8) are secured to the disks. Current is carried to each head from current collectors 4 through collector rings 1.

The rotation frequency of the blooming mill roll when being case-hardened is $n_1 = 1.0$ rev/min, revolution frequency of head $n_2 = 40$ rev/min. and longitudinal feed $s = 1.2$ mm/rev. Alloy 1Kh18N9T is used for the material of the alloying electrode.

Since electro-spark case-hardening of the roll is most efficient at the indicated modes, current generators were used for each contour according to a circuit consisting of a starter, a VSZh-303 rectifier and a type RB-301 ballast rheostat with spark-arresters connected to them. The current from the positive pole of the generator is carried by the current collector through the collector rings and further to the electrodes, while the current from the negative pole flows directly to the part by a spring-loaded sliding contact.

As shown by experience in operating the rolls, electro-spark case-hardening of periodic rolling rolls and blooming mill rolls produces a microcontour on them that facilitates the elimination of skidding of rolls in operation and good gripping of the intermediate product, as well as increasing the durability of the rolling 1.5-fold on the average.

COPYRIGHT: Izdatel'stvo "Mashinostroyeniye", "Mashinostroitel'", 1984

2291

CSO: 1823/315

OTHER METALWORKING EQUIPMENT

BRIEFS

HEAVY-LIFT LOADING PLATFORM -- Kirov -- An original heavy-lift loading platform was developed at the Kirov Heavy Machinebuilding Institute. A platform with a 10-ton load can literally be moved by "one finger!" The loaded platform is lifted straight into the air overcoming the force of gravity by means of several modules, air cushions filled with air from the plant pneumatic network. Thus, the necessary pressure is produced and the loading platform, rising hundredths of a millimeter, can be moved in the desired direction by only one worker. The experimental plant of the institute will fill the orders of the Zhdanov, Sverdlovsk, Rostov machine builders in the country before the end of the year. [Text] [Moscow SEL'SKAYA ZHIZN' in Russian 19 Jul 84 p 1] 2291

MAGNETIC ABRASION POLISHING -- The Minsk Machine Tool Building Plant imeni S. M. Kirov introduced into production magnetic abrasion polishing of flat parts. This process was developed by the Minsk branch of the "Orgstankoprom" Institute. A special device is used for this purpose. It is a magnetic inductor that creates a magnetic field which retains a ferromagnetic powder at the poles of the electromagnetic cores. A vertical-milling machine tool with a rotary movement of the inductor and a reciprocating movement of the part does the polishing process. The use of the magnetic abrasion polishing facilitates a considerable increase in the quality of the polished surfaces and the productivity of labor, making it possible to reduce manual labor in polishing operations. [Text] [Minsk SOVETSKAYA BELORUSSIYA in Russian 20 Jul 84 p 2] 2291

NEW HEAVY DUTY PRESS -- Voronezh -- Units of a new 6300-ton superpowerful press were loaded on several RR flat cars for shipment to Chelyabinsk. This press was manufactured by the Voronezh Heavy Mechanical Press Manufacturing Production Association. It was made to stamp parts for heavy trucks up to 13.5 meters long. When assembled, this "supermachine" will weigh 1100 tons. And this after the designers of the association, in cooperation with scientists of the Moscow Machine Tool Building Institute, reduced its metal consumption by a third as compared to the best similar presses in the world! At the same time, the productivity of the giant press was increased 1.6-fold with a considerable increase in the accuracy of stamping by using computers. The press, considered unequalled by specialists will make it possible to save about a million rubles per year. At present the plant collective is assembling an automatic line which, in one "pass" will produce finished crankshafts and axle beams for "ZIL" by the hot stamping method. This line, 70 meters long, will include

the final heat treatment and will be essentially equivalent to an independent shop. The collective of such a "shop" will consist of ... four operators. [By PRAVDA correspondent A. Starukhin] [Text] [Moscow PRAVDA in Russian 5 Aug 84 p 1] 2291

PRECISION PARTS CASTING MACHINE -- A machine whose tests were completed in the Dnepropetrovsk Heavy Press Production Association is capable of producing parts directly from liquid metal. The new technology has great advantages: under pressure the molten metal fills the compression mold with uniform density insuring a homogeneous structure of the future product. Finished parts require only finishing machining. Metal waste is halved. [Text] [Moscow MASHINOSTROITEL' in Russian No 5, May 84 p 33] [COPYRIGHT: Izdatel'stvo "Mashinostroyeniye", "Mashinostroitel'", 1984] 2291

CSO: 1823/362

ROBOTICS

GROWTH, FUTURE OF SOVIET ROBOTICS SECTOR ANALYZED

Moscow ZNAMYA in Russian No 8, Aug 84 pp 161-176

[Article by Viktor Gerasimov and Nikolay Petrov]

[Text] A guest meeting of the board of the Ministry of Instrument Building, Automation Equipment and Control Systems was held in Leningrad in May 1982; at which a long-term sector program for robotization was adopted.

A representative seminar "Industrial Robots," in the work of which participated several hundred specialists from all industrial regions of the country, was held in July 1982 at Moscow within the framework of the program "Leningrad Days" at USSR VDNKh [Exhibition of Achievements of the National Economy].

An international exhibition "Robot Engineering and Robot Technology," in which participated enterprises and companies of 20 governments, was organized in October at Leningrad.

These three events are related in one way or another to the birth of a new sector of industry--robot construction. But the greatest experience in development and application of industrial robots (automatic manipulators with program control) and organizational forms of work in this direction has been accumulated at Leningrad. The problem was investigated here earlier than anywhere else on a serious basis and on wide scales and greater success was also achieved here than anywhere else. Leningrad has a long and stable reputation as a unionwide center of robotics; people travel here from the entire country for experience. One can often hear from the new arrivals: "Yes, it's not because of the good life that you are involved in this." And Leningrad residents do not conceal it: Yes, it is not because of the good life. An acute shortage of work force in our largest industrial center forced us to seek additional methods of increasing the labor productivity at enterprises. The search has long been conducted in many directions: specialization and concentration of production, which opens up the possibility of mechanization and automation of it, and reduction of the volumes of manual labor, optimization of the structure of production, improvement of management of production--development of a network of production and scientific production associations, and over a period of several of the last few years--also extensive robotization of shops and sections.

Several Leningrad associations debate where robots appeared for the first time. We will not judge this. And this is why.

One of us very long ago, it is terrible to say, managed to prepare a topical page of PRAVDA in 1958 about the experience in development and work of the first automatic shop in our country at the first Moscow Bearing Plant. This was an amazing shop. Many different types of mechanical devices, without human participation, themselves took the parts from storage racks, placed them in the machine, secured them and then transferred them either to the next machine or to the packing section, from where the finished product was sent to customers. This made a strong impression on an at that time quite young journalist. He was still looking for a word that would characterize clearly and precisely these amazing devices. He looked and he did not find it--after all, the word "robot" was not at that time in the broad engineering lexicon, but came into it later.

One now thinks: were these loading-unloading and transport devices robots according to our current concepts? Undoubtedly! True, they were the most elementary and with the lowest skills compared to modern robots--self-teaching, self-memory, capable of distinguishing visual symbols and so on and so on. But even these quite simple robots were necessary. They are now of course much improved over their predecessors, but in principle many of them have very similar kinematic diagrams and perform the same operations.

So that work on robot-type devices has been carried out for decades now in our country. The boundary between a robot and a device that transfers parts from machine tool to machine tool according to a specific program is unclear: one can call such a device a robot and one may not call it such--the essence of the matter hardly varies. Therefore, it is difficult and practically impossible to state: yes, robots appeared at such and such a plant earlier than at such and such an association. A factory is always found which presents proof that it had the first operating robot long before it was assembled at a plant and at an association.

And nevertheless, several Leningrad enterprises are still named where robots, seriously and with scope then became involved earlier than others. Specifically among the first ones are the Association Leningrad Electromechanical Plant.

The first robot appeared here almost 10 years ago. It did not arouse any special enthusiasm among the workers. This was a cumbersome device, serially produced at that time by industry, quiet-running and low-productive. One experienced stamp operator could easily surpass the norm of several of these "assistants" per shift.

Why then were they not immediately rejected at the association and why were experiments continued? We know the answer: not because of the good life. It was much more complicated to hire new stamp operators than to acquire tens of other robots.

And now in 1984 we are at a fully robotized stamping section. There are almost no people, few of them--28--are behind the presses--there are only

robots. The single figure of an adjuster is sometimes found at one or another unit. He inspects it, sometimes adjusts something and again returns to his place at the far end of the section. Incidentally, there are still operators and each "is responsible" for approximately five robots. But this is perhaps overinsurance. People are principally not necessary here and at some time they will not be here.

The stamping section operates without shift changes and without lunch breaks. And robots are gradually appearing in other sections--in drilling printed-circuit cards, manufacture of equipment chassis; there are also controller robots.

"By the end of the five-year plan, 150-180 robots will be introduced in the association," states the general director Yevgeniy Petrovich Sharapov. "We are simply unable to fulfill the plan without them: after all, the volume of production must be increased 1.6-fold, while the number of workers must be reduced by 2 percent. Incidentally, you cannot get along in any case without mechanical assistance: there is now no one who wants to work in stamping--such a large city as Leningrad is quite capable of offering people some more interesting and rewarding and even better-paying work. But the robot maintenance operator is a respected occupation and people willingly learn it. Incidentally, we are training operators at the PTU [vocational technical school] of our association.

There is still another plant--the Petrodvorets Clock Plant. It produces men's wristwatches, four million annually. Jewelers work--assembly of the watch mechanism--has truly been entrusted to robots.

The labor on an assembly line is monotonous and boring and people do not tolerate it continuously. Young workers were recruited and they were trained in a hurry. They were not very skilled assemblers and this was of course reflected in the quality of the watches. So that they could not get along without robots. Cooperation with the Moscow Special Design Office of Watch and Jewel Machine-Tool Building helped the plant here. Through their combined efforts, special lines and small standardized automatic manipulators with extensive production capabilities were designed and constructed within a comparatively short deadline. The design of the watches themselves was improved at the same time--it was adapted to robot technology.

And here we see how a robotized automatic assembly line operates. The watch mechanisms are placed in hoppers--five in each--and this is just about the only operation that is performed manually. The small robots that have replaced the assemblers install the parts on the positions designed for them (five parts at once!), lubricate the working surfaces and tighten the screws. A manipulator requires 6 seconds to install 10 parts. The shop managers produced a list: each foreman assembled from 200 to 600 sets of mechanisms per shift previously; a robot assembles up to 4,000.

The automated assembly section now consists of 42 lines equipped with more than 170 robots. Operation of this technology brings millions of rubles profit to the enterprise. The labor of 1,800 workers is saved--this is how many people

would have to be recruited to the plant additionally with regard to the continuously increasing volume of production. Turnover of personnel is reduced and no shortages of personnel have been experienced for a long time now.

"This is of course the direct effect of robotization, but there are also indirect effects," says the plant direction Vasilii Yakovlevich Gorshkov. "The volume of production noted by the State Badge of Quality, increased sixfold with introduction of manipulators. Watches are produced here with only the first and increased classes of precision. The output of watches with all types of additional devices increased fourfold during the past five-year plan --their fraction is approximately 40 percent in the total production volume.

It is not without interest that six watch mechanisms were previously produced, while now one "basic" model, adapted to robotized technology is produced. And watches with single or double calendar, automatic winding, antimagnetic and so on are produced on its basis. Moreover, the repair of the watches is facilitated and simplified.

We note in conclusion that a large group of workers of the Petrodvorets plant and other specialists of the clock industry was awarded the USSR State Prize in 1979 for a series of brilliant, original papers on industrial robotization.

Practically all Leningrad plants, associations and scientific research organizations of an industrial profile are making their contribution to industrial robotization. Take stamping robots, assembly robots and many others. Is there anything that robots will not be involved in? Absolutely not! Investigations are being conducted within the framework of the country's first regional program of industrial robotization.

Everything began with the decision several years ago of the office of the CPSU Obkom at Leningrad to form a territorial coordination council on problems of robotics. It included leading specialists and managers of planning, design and production organizations and production associations. The first robots of five modifications were developed on a cooperative basis. Specific organizations and enterprises were responsible for the production of each of them and of individual assemblies. The plants were determined at which it was planned to introduce robots, primarily sections with the most laborious and low-attractive processes: stamping, machining, casting and mass assembly of products. Moreover, a large-scale problem was then posed: to design and introduce robotized production complexes rather than individual robots so that the entire cycle of product manufacture--from delivery of blanks from the warehouse to transfer to the next section or to delivery to customers--be performed by manipulators in the automatic mode.

The first robots were manufactured and introduced at 10 basic enterprises with the participation of a number of production institutes. Approximately 50 plants and associations were then included. They thus did not begin from nothing--they mainly modified and adapted what had already been developed to their technology.

The clear organization of the matter, established on a carefully thought-out and universal plan, produced its fruits. During the last 3 years of the last

five-year plan, the stock of industrial robots increased sixfold at Leningrad enterprises. Comprising approximately 30 percent in the country's industrial potential, the city on the Neva concentrated approximately 10 percent of the unionwide stock of robots. The beginning robotization of industry, as at the Petrodvorets Watch Plant, not only released people from heavy, monotonous operations and led to an appreciable increase of labor productivity, but also produced a discernible side effect: the shift factor increased, the utilization of equipment was improved and product quality and overall production skills increased.

The second integrated five-year program on industrial robotics is now being implemented. A total of 88 enterprises and organizations is participating in implementation of it. And the main thing is that it has become a section of an integrated plan for the economic and social development of Leningrad Rayon and has acquired the force of law. In other words, the level of responsibility of everyone involved in its practical implementation has increased significantly.

The experience acquired during past years and scientific level were also felt: the quality of the document and its economic and organizational substantiation increased appreciably. The program envisions the development and introduction of standard robot production complexes and so-called "production cells" (machine tool and manipulator) at basic enterprises--they will be copied after extensive tests. There will be approximately 1,000 of these cells, which operate in the general production line and interact with other machine tools and units. Serial output of robots and control devices based on the modular principle is planned. This offers the capability of assembly of robots of different designation and "capacity" from single, standardized parts, similar to how the parts at machine building and other plants are assembled by universal assembly devices. It is also planned to create prototype demonstration sections and shops to develop completely new principles of integrated automation of production. A program for development of robots for automation of a number of processes in agriculture and in the light and food industry has been prepared. All this was not contained in the first program.

The second Leningrad robotization program is separated from the first by some 3 years. And even so a qualitatively new document has been developed. There are now several times more robotics specialists at Leningrad than in the previous five-year plan. They were concerned about this in time. A constituent part in the overall plan of industrial robotization included the program of training and retraining of specialists. Courses at the Polytechnical Institute imeni M. I. Kalinin were specifically organized for them--the 14th or 15th contingent is already being trained. The three faculties of this institute have graduated approximately 500 engineers in whose diplomas is noted: "Engineer in robotics and robot engineering complexes in such and such (the notations are different here) sector." Training of workers--specialists in adjustment and maintenance of robots--has been organized in 13 vocational-technical schools of the city. The training programs of a number of Leningrad technical and economic vuzes have been changed: upperclassmen take a course in robotics and they are trained to control manipulators during production practice; the same corrective courses will be introduced in the near future in

programs for students of junior courses as well and also technical schools and vocational-technical schools. An extensive training program in robot design and working with them is also planned for the current five-year plan.

A serious program--with lectures and seminar exercises, with course and diploma projects and with a solid theoretical basis--has been designed mainly for engineers, technicians and workers who have decided to devote themselves to robotics and who have elected it as their life's work. But thousands and even tens of thousands of other specialists should also have a knowledge of robotics. Let us say, economists, rate setters and technicians. Or specialists from those comparatively small enterprises--and there are rather many of them in Leningrad--were one or two from among tens of automatic manipulators who will appear during the next few years.

An extensive network of short-term and permanent seminars, cycles of lectures and also Specialist Days has been organized for these categories of workers--they are being conducted on the basis of the Leningrad House of Scientific and Technical Propaganda. On specific days, everyone who is interested in problems of robotics consults prominent scientists and important managers in this old house on Nevskiy Prospekt. And if one wants to see how robots operate, one can visit the same Petrodvorets Plant or another enterprise--more than 500 of these excursions have been conducted during the past 3 years. More than 2,000 specialists have participated in different activities that acquaint them with experience in the use of industrial robots.

As we see it, extensive work is being carried out in many directions. Who compiles the plans, corrects the vuz programs and organizes the lectures, consultations and excursions? Who conducts the large orchestra that performs a large-scale robot symphony and who coordinates and directs the work of the many enterprises and organizations and the combined efforts which solve on a general background the grandiose, large-scale problem of robotization of Leningrad industry?

The Central Scientific Research and Experimental Design Institute of Robotics and Engineering Cybernetics attached to the Leningrad Polytechnical Institute imeni M. I. Kalinin writes the score for the orchestra, while the Coordinating Council on Robotics attached to the Leningrad Obkom of the CPSU stands behind the conductor's podium. It was created by decision of the Obkom office in 1977. Professor of the Leningrad Polytechnical Institute Yevgeniy Ivanovich Yurevich heads it. The council operates mainly through its five sections.

The coordinating council is the main author of the Integrated Program for development and introduction of industrial robots at Leningrad enterprises and in Leningrad Oblast for 1981-1985. This program initially envisions the following positions: to create three shops, 24 sections and 951 robotized cells --to introduce approximately 1,200 robots--by the end of the five-year plan. We note that the word "initially" is not meaningless here--the program is now being reviewed and on a very substantiated basis at that. Its fruits are discernible. Let us say, 2,785 industrial robots and automatic operators had already been introduced at Leningrad enterprises at the beginning of the current five-year plan. Incidentally, not only the rates of introduction are

remarkable. The "ideology" of automation itself has been raised to a new level. The course has been taken toward development of flexible automatic plants, where the design and manufacture of articles are carried out by a complex of equipment at the instructions of a computer, which controls the entire process--from drawing to sending the parts to the warehouse. It is here that robots are most useful and efficient. But, as the operating experience of the first flexible plants shows, robots also should be improved so that they are capable of being subject to computer control over a wide range and not only in performing several permanently programmed movements. Unfortunately, there is presently a shortage of these robots. So that specialists in the field of engineering cybernetics were concerned early. The problem must be solved persistently and in time, without waiting until an extreme shortage occurs.

Leningrad already has something to show for what is planned for robots on a serious and long-term basis. Therefore, the guest meeting of the board of the USSR Ministry of Instrument Building, Automation Equipment and Control Systems was held here in the summer of 1982, at which only the sector "Specific integrated scientific and technical program for development and introduction of robots, manipulators and robot engineering complexes at enterprises of Minpribor for 1982-1986" was discussed and then adopted, similar to the Leningrad program.

It has sometimes become current to call this program "the second five-year plan of instrument building."

We asked the Minister of Instrument Building, Automation Equipment and Control Systems of the USSR Mikhail Sergeyevich Shkabardnya whether he feels that the robotization program is really the second five-year plan of the sector and whether the time has come for such extensive, truly mass introduction of robots which the program envisioned.

The minister is attracted by the idea of robotization and does not conceal this. Incidentally, the attractiveness is obviously inherent to him in general. The very effective Krasnodar system of labor and product quality management is very well known. So that, M. S. Shkabardnya was in fact the developer of this system during those comparatively recent years when he headed an instrument building plant in the kray.

"There is an urgent need for these industrial robots now rather than the remote future!" the minister exclaimed in response to our question. "Approximately 1,000 of them operated in the sector in 1982 when the sector program was adopted; there will be 30,000 in 1986!. This is a thirtyfold increase and can be no less. None of the subsectors of the ministry is taking such a sharp jump."

Questions immediately arise. For example, why is it now necessary to increase the output of robots? Perhaps, something was omitted or they were not concerned about something previously or because a need for an interruption or in a unique assault occurred? And in reality can the sector be equipped with thirtyfold more robots within such a short time?

"Why do you say 'assault'? The rate of introduction of technical innovations is ordinary after accumulated data and experiment has reliably confirmed the high effectiveness of widescale application of them. The very first robots appeared 10 years ago in the watch industry. They now operate in more than 100 instrument building enterprises. It is now clear: despite the relative complexity and expense, it is more feasible to use robots and it is more advantageous practically everywhere. And why postpone introduction of them 'until later'? Is it not better to take on the entire world and solve the problem within 10 or 12 years?"

The words "entire world" very precisely characterize the content of the sector robotization program, about which the minister told us somewhat later. And he named the period of 10-12 years because 30,000 robots, of course, sounds impressive but, according to the estimates of specialists, this is less than half as many of the number of automatic assistants which the sector needs. Only the short-term prospects have essentially been planned."

Thus 'sector robotization program.' This is a small book of 60 pages of small text. There are many tables--mainly the tasks for the All-Union industrial associations and sectors. We easily found the answer to practically all questions of interest to us in this small book.

Who will design the robots? The main burden falls on the Scientific Research Institute of Heat Engineering Instrument Building (NIItekhpribor) at Smolensk. And responsibility for scheduling the work and introduction of robots is entrusted to the Moscow Scientific Production Association Temp. Moreover, individual specialized and comparatively little-used types of robots will be developed at nine institutes and KB [design office] of the sector at Leningrad, Riga, Yaroslavl, Gomel and other cities. And who will manufacture the robots? This is perhaps the most interesting part of the program. Strictly speaking, there were no robot construction plants in the sector at the time the program was compiled. A total of 120 of 169 robots developed in the Minpribor system in 1981 was made at watch plants and were introduced in the watch industry.

By the end of the five-year plan, the sector will include five large, well-equipped plants, for which serial output of robots will become their main occupation. The largest of them--Ramenskoye and Mogilev--are designed to manufacture 2,000 robots each annually. The first lots--approximately 50 units each, were produced in 1982. Robots will become the main business for the All-Union Association Soyuztekhnopribor as well. The plants of this VPO [All-Union Production Association] will produce more than 7,000 robots during the last year of the five-year plan. The watch industry will produce another 6,000 or more. The plants of the sector will receive a total of a little more than 15,000 robots--almost 100-fold more than in 1982 and 25-fold than in 1983.

The figures are impressive. They would probably raise doubts if they were not so convincing. The future robot building plants will not begin to operate alone. These will actually be assembly enterprises while tens of other plants of the sector will deliver the most important components and elements of robots to them. This approach is logical. One wishes to find reliable assistance, help in production; then make your own contribution to implementation of the robotization program.

This program envisions not only expansion of robot production. For the sector to receive 15,000 robots this year rather than in 1985 when they simply do not have enough work. Why?

"If a worker finds that two parts do not go together and do not join, he can correct something, clean something, remove burrs or apply physical force," explains the chief engineer of Soyuztekhnopribor Ivan Danilovich Goloto.

"There is no reason to train this robot--only parts of excellent quality are delivered to it so that everything proceeds without a hitch and without problems. Extensive introduction of automatic manipulators requires a different, higher production skill. Robotization is not simply installation of robots alongside machine tools. In most cases this is also a fundamental restructuring of technology, an increase of the class of fit of parts, clearness and rhythm in interaction of sections and shops, training of cadres of highly skilled workers and specialists, improvement of management of the enterprise and much, much more."

Minpribor has now taken on itself to raise the level of the technical equipping of their own enterprises by extensive introduction of robots and different, but other ministries will tomorrow be faced with different, but also urgent problems that require urgent solution. And this experience and example of Minpribor may be helpful and useful in our view. There is much new in this experience--such that has not been previously used in our industry. Let us say, territorial robotization centers.

The enterprises of Minpribor are geographically dispersed through all industrial regions. And even so, if one looks at a map, one can detect some "constellations" of instrument building plants. There are approximately 10 of them in Leningrad, eight in Kiev and near it, as many in the Baltic region and 12 in the Volga region. And each such cluster (there are 19 of them) has one or two collectives which have become more successful in introduction of robots and which have accumulated some experience in this new business for the main mass of instrument builders. They have also been determined as the base organizations for all work related to robotization--each one is called upon in his own region to assist other collectives to prepare sections and shops for introduction of automatic manipulators.

Yevgeniy Petrovich Sharapov, the general director of the production association Leningrad Electromechanical Plant, manages the territorial robotization center at Leningrad. What has been done here?

"The basic robotization section of the All-Union Industrial Association Soyuzschetmash has been organized at our association," says Ye. P. Sharapov. "It includes approximately 10 specialists. Their functions are as follows: to study the situation at enterprises, to nominate sections that are most in need of the use of robots, to recommend which modifications it is best to utilize. A clear program was worked out on the basis of examination of Leningrad--associations Burevestnik, Petrodvorets Watch Plant, Soyuz, Vibrator and others: the number of robots must be brought up to 2,370 within 5 years at the Leningrad enterprises of Minpribor. But it is of course not a matter

of numbers. The main task of the center is to determine what and where to install them, bearing in mind integrated rather than partial automation of production, and to accustom managers and specialists to like it. With regard to our association, it frequently becomes a test range where very diverse robots and complexes will be offered. The purpose is to demonstrate models of progressive equipment and operation to the directors of production and to engineers: come, look, learn and select. Moreover, the doors are open not only to instrument builders but to representatives of other enterprises as well.

The director of NIItekhnopribor Stanislav Petrovich Kronshtofik is manager of the Smolensk Center.

"The colleagues of the institute, having examined all enterprises of our cluster, determined sections where it is feasible to use robots and determined the priority of installing them," says the director. "We help the plants to staff groups of specialists which will be involved in introduction and operation. A consultation station has been equipped--we give out advice and recommendations to engineers and managers of other enterprises regardless of their departmental subordination. Many have expressed interest in the new direction. The Orsha Machine Building Plant of Minleppishchemash [Ministry of the Light and Food Industry] has already developed close ties with our territorial center. As it turned out, the developers of sewing machines also need robots and they feel that cooperation with instrument builders in this field will help them to solve many problems."

The "Proposition" of a territorial center, confirmed by the board of Minpribor, has the following item: "Organization of direct ties to the enterprises and organizations of other sectors to produce and introduce robots and manipulators is included in the tasks and duties of the center."

Is not Minpribor taking a lot on itself, having voluntarily elected to assist "outside" enterprises that are not instrument building concerns in introduction of robots?

There is sufficient evidence that this is not a lot. Let us say that when an extensive conference of the managers of the sector, devoted to further development of technical progress, was held at Orel, the managers of many other non-instrument building enterprises were invited. This was a good school of leading experience for the hosts of Orel workers. The party Obkom recommended that the plant directors visit the Prompribor association--the base for introduction of robots--more frequently and borrow the methods of solving complex scientific and technical problems.

The enterprises of different sectors located in the same region frequently must solve similar problems: to develop production of consumer goods, to create auxiliary farms in rural locales and so on and so on. Things are going better in some collectives and worse in others. And why not create territorial interoblast and intersector centers here which would familiarize the collectives with leading experience? Large additional staffs would not be required and the benefit from borrowing leading experience and exchange of it would leave no doubt.

But let us return to the robotization program. Yet another important innovation considered by it is introduction of a main robot designer institute.

Four directions have been determined in the vast and scattered sector--robot engineering and robot technology: in his order, the minister appointed specialists responsible for development and introduction of manipulators for each of them. The range of duties of the specialists is just now "becoming settled." But it is clear that they should have greater rights. After all, personal responsibility also means personal rights.

Incidentally, we heard the words "personal responsibility" rather frequently during conversations at Minpribor, at its enterprises and in organizations. Robotization is a delicate and specific matter and it is necessary that there be people in each collective that are involved only in robotization and nothing else--both the minister and the chiefs of the All-Union associations and the directors of enterprises told us this.

These people are now present in almost all plants of Minpribor. And special robotization offices have been formed at many of them. They did not appear everywhere without resistance of individual managers. They said why is this necessary--there are already offices and departments of mechanization and automation at the plants?

True, there are. There was such an office, for example, at the Leningrad Association Vibrator--one of the largest in the sector. But matters were not proceeding with respect to robots--they were being introduced slowly and unwillingly. The forces of specialists were simply being scattered in many directions and they did not have enough time for manipulators. So a robotization office was created and within a year 12 robots appeared at Vibrator.

It was also mentioned that not all plants of Minpribor are ready for introduction and use of robots. Where the quality of blanks and parts is low and where there are few highly skilled workers and specialists who know how to handle complicated equipment and where there is simply a shortage of elementary procedures and where production skills are low. These collectives must still learn a lot. Experimental demonstration sections, equipped with a full set of robots, as it is said, on a high level, are being created for this. They will appear in other regions in time.

There are several of these sections at Orel Prompribor. One of them is in the stamping shop. Five presses, on which parts of 35 items are manufactured, have been equipped with robots. This is scarcely a large number, but due to the introduction of these manipulators the number of shop workers was reduced from 427 to 307 and output more than doubled. This is a saving. And there is a social effect. People of the lowest skills, whom it is not easy to hire at other enterprises, are willingly taken into the shop: those who must work for several months before going into the army or before entering an institute. After all, to "supervise" robots does not require special skills.

"What concerns the manager of this plant?" we asked the deputy chief of the shop V. V. Bolotin.

"How to keep the robots fully loaded and where to find storage spaces for the products produced by them," he answered. "After all, they complete the annual program for some parts within five 8-hour shifts."

There are 33 robots at another experimental demonstration section, where temperature regulators for refrigerators of almost all Soviet brands are manufactured. Previously, 700 persons produced two million temperature regulators annually. Only 350 persons now remain, but the program is seven million regulators.

"Our section was created last year, but all expenditures have already been recovered," said the deputy chief of the shop, manager of the All-Round Automated Temperature Controller Plant N. S. Serezhnin. "And not only because of the saving. The country has gained millions and millions of rubles due to improvement in the quality of instruments."

This is true. There was a time when letters with complaints about the quality of refrigerators literally arrived in bundles at the editorial offices of central newspapers (the refrigerators mainly failed due to low reliability of the temperature controllers). These letters have now decreased appreciably. Prompribor rarely receives complaints now. But the rejections usually occur from those production sections where there are no robots--part of the controllers are still manufactured by the old technique.

These same sections are agitating for introduction of robots where they are more effective than information materials and orders. And in order that the robotization program be fulfilled as rapidly as possible, Minpribor has introduced a number of additional incentives for enterprises and individual robot specialists who vigorously introduce robotics.

Thus, beginning in 1982, besides the "13th wage" known to everyone, workers and specialists who design, manufacture and introduce robots and who work with them and maintain them, have begun to receive a "14th" bonus at the end of the year--an impressive bonus in size. It was decided to award their participants with memorable gifts after completion of extensive and significant work in the field of robotics. The developers of the robotized production of temperature controllers received the first of these gifts--engraved watches. The minister M. S. Shkabardnya himself handed them to six engineers of Prompribor.

This is a joyful event, but there are still some sad reflections. Why does robotization of production--hardly an indisputably effective and feasible field--still require a unique type of "thrust?" Why is not everyone interested in introduction of robots into the national economy?

It is now difficult to encounter open opponents of robots and robot engineering. But there are people who have a reticent and careful attitude toward them who assure us that there is still much unclear here and they have not received reliable and conclusive answers to all their questions. The main argument was this: robots are still expensive and insufficiently efficient--they do not everywhere and do not always pay for themselves rapidly.

True. There are many robots in industry and in Minpribor itself which, if you believe the calculations according to the presently used methods, will not pay for themselves within 5 and even 10 or 20 years. The simplest robot costs as much as a Zhiguli automobile costs. They do not completely release people from sections--man is still necessary to monitor two-three or more rarely five robots. And there is the highly paid and skilled adjuster or one and the other to service them, adjust them and to repair them. Compare the wage of these people with the cost of robots and it will give you something to think about.

But we especially stipulated: "if you trust calculations according to the presently used methods." It is these methods that we can confirm are imperfect and do not take many factors into account.

We asked the general director of the Orel Association Prompribor L. F. Kuklik whether the shops have inadequately efficient, unprofitable robots and he answered frankly:

"Yes, there are!" And he added, "But we will continue to introduce them. Because they are effective for the country."

This is how the most experienced manager, director of almost the best association of the sector, for many years the leader in the competition, which annually confirms the rank of "enterprise of communist labor," and winner of the challenge Red Banner of the CPSU Central Committee, USSR Council of Ministers, AUCCTU and Central Committee of the Komsomols. One cannot help but agree with his opinion and his opinion must be taken into account when reviewing the methods of calculating the efficiency of robots and there is no doubt that the time has come to review this method.

But if only one were limited to the difficulties which the developers of robots encounter! The chief engineer of Soyuztekhnopribor I. D. Goloto related some of them.

Electric motors. They are special in robots--compact and even miniature, can change direction and rotational speed rapidly and obediently follow the assigned program. The plants of Minelektrotekhprom essentially do not make them and are not especially trying to.

Hydraulic assemblies and elements. It is quite possible to use hydraulic devices in robots. But the instrument builders did not even attempt to reach an agreement with the machine tool builders. Everyone knows that hydraulic devices are not themselves sufficient.

Sensors. The situation is somewhat better here. A plant was found in a related sector, which produces them, and an agreement with its "host" ministry was reached about exchange of several robots for sensors. These types of exchanges, incidentally, are not excluded by the robotization program. The instrument builders, for example, feel the agreement with the Volga Automotive Plant, which has taken on large-scale production of robots, very advantageous. Three hundred robots were "exchanged" for a large lot of plug connections which the motor vehicle builders needed.

What then, are the robots which the motor vehicle builders make completely adaptable at instrument building enterprises? Why then make a fuss--they would buy several thousand and then even tens of thousands of robots from the same VAZ [Volga Automotive Plant] and the matter would end. What sense is there in developing similar designs!

Two years ago Minpribor organized a large exhibition at the suburban Moscow town of Ramenskoye at the Tekhpribor Plant. Robots manufactured at enterprises not only of this ministry but in the automotive, electronics and radio industries as well, were displayed at it for comparison. To compare and make conclusions, it must be said, was not easy. The productivity of the same types of devices is approximately identical, the price also, but they differed extremely in external appearance. Each of the robots, identical in designation, productivity and operating principle, had their "own" parts. Each department was proceeding along a special path, clearly unproductively and inefficiently expending the efforts of its specialists.

Of course, there is nothing bad in competition of different sectors as to whose robot is better. It is important only to select in time the most efficient designs, supplement them with successful solutions found in other sectors and to organize mass production. Alas, this is always far from done.

Why it is never done is a special subject. We have already talked about establishing robot construction on the example of a single region--Leningrad and Leningrad Oblast--and in a single sector--instrument building, automation equipment and control systems. Let us stipulate at once: there are other ministries as well where work is being conducted on development and introduction of robots. There is also an intersector integrated robotization program, in implementation of which the enterprises of many departments participate. They will probably in time combine their efforts in development of robots and robot production complexes. But at present they have approached this important matter only at Minpribor as toward development of a new competent sector.

This is not a rebuke of the remaining ministries. After all, robots in themselves as engineering devices correspond more to the profile of instrument building enterprises. Creation and establishment of a new sector is a vital matter for instrument builders. In the given case, the most essential is not that they have taken it on as that they would have to take it on. It is important how they took it on--in an organized manner, with wide-range and initiative, inventively and at the same time on a planned basis. In short, at the level of modern control science.

How is the experience of the instrument builders valuable? Primarily by the fact that robot construction at Minpribor is acquiring the features of an independent sector more rapidly than in other sectors, with its inherent elements and attributes--this is a group of specialized robot building enterprises, scientific research institutes and design offices that are responsible for technical policy and this is a clear long-term plan that provides very high rates of growth of production. However, this does not mean that other sectors are standing aside.

Large-scale production of robots has been organized, for example, in the automotive industry. The Volga Automotive Plant at Tolgliatti supplies many enterprises of the sector with them. The machine tool builders are preparing to increase sharply the output of robots and, specifically, they will provide the excellently equipped building of the Moscow plant Krasnyy proletariy-- construction of it is now being completed.

And the establishment itself of a new sector was also begun much earlier with other than the sector robotization program. The director of the Central Scientific Research and Experimental Design Institute of Robotics and Engineering Cybernetics attached to the Leningrad Polytechnical Institute imeni M. I. Kalinin Professor Ye. I. Yurevich feels that the establishment of Soviet robotics has passed through three main phases.

The first was begun in 1972, when the State Committee for Science and Technology first formulated the problem and methods of solving it in its decree. The first plan of operations in the field of robotics was then confirmed, having encompassed 19 sectors and departments, including the USSR Academy of Sciences and the USSR Ministry of Higher and Secondary Specialized Education. Industrial robots of 30 brands, suitable for serial production, were developed during implementation of the decree and plan.

The beginning of the second phase was 1974. A program of investigations in the field of robotics was compiled for the 10th Five-Year Plan under the supervision of the State Committee for Science and Technology. Measures, directed toward integrated unification and standardization of robots and their elements, were undertaken. Robots of new types and of a higher class--with adaptive control (self-teaching)--were developed. A specific scientific and technical modification appeared. The main industrial ministries were the first to receive the assignment to produce industrial robots of different designation. The head organization was determined--the OKB [special design office] of Engineering Cybernetics, Leningrad Polytechnical Institute, subsequently transformed to TsNIOKI [Central Scientific Research and Experimental Design Institute] of Robotics and Engineering Cybernetics. Important fundamental and research work was carried out under the supervision of the Scientific Council of the USSR Academy of Sciences for Robots and Robotics Devices.

Regional robotization programs, based on combining the efforts of several enterprises and cooperative production of robots, were developed during the same phase in a number of the country's oblasts. These programs--they became a constituent part of the regional integrated plans for economic and social development--were specifically developed at the initiative of the Leningrad and Vladimir Obkoms, the Krasnoyarsk Kraykom of the CPSU and the Nikolayevsk Obkom of the Ukrainian Communist Party. As was already noted, the Leningrad workers were more successful than the remaining ones in development and introduction of robots. The number of robots in Leningrad and in Leningrad Oblast increased fourfold during the second half of the 10th Five-Year Plan and comprised 10 percent of all the country's robots by the beginning of 1981.

The third phase was the 11th Five-Year Plan. The decree of the CPSU Central Committee "On measures to increase the production and extensive use of

automatic manipulators in sectors of the national economy in light of the instructions of the 25th CPSU Congress," was adopted in July 1980 and the decree of the CPSU Central Committee and of the USSR Council of Ministers "On increasing the production and introduction of automatic manipulators with program control (industrial robots) into the national economy during 1981-1985" was adopted in June 1981. The problem thus became statewide in nature.

Has much been done during all three, let us assume the first phases of robotization of the Soviet economy? Generally much has been done. Let us cite the opinion of a specialist. This is what the deputy chief of department of USSR Gosplan V. Lebedev in an article published by PLANOVOYE KHOZYAYSTVO:

Soviet robotics has travelled the path during the past 7-8 years from development of the first experimental models of robots to organization of serial production of them and introduction into industry. More than 100 models of industrial robots and manipulators have been developed for automation of the processes of stamping, machining parts, application of galvanic coatings, casting, welding and painting, assembly and other production operations. Production of individual complexes of machines has been organized for pressure casting, equipped with industrial robots; automatic adjustable sheet-stamping lines based on mechanical presses with force up to 100 tons with industrial robots and individual modules of robot machine tools have been developed. Automated sections are being created.

At the same time, the rates of assimilation and organization of developments and the volumes of production and introduction of robots did not meet the requirements of the national economy. The absence of coordination of work in robotics leads to unjustified duplication of engineering developments and insufficient, economically substantiated use of one or another manipulators. A single method of calculation and manufacture of both universal and of the simplest inexpensive industrial robots and manipulators must be developed. Upon introduction of universal industrial robots at individual enterprises, one must avoid steps and functions of them that are not required in specific types of production, which leads to unjustified expenditures. Minstankoprom [Ministry of the Machine Tool and Tool Building Industry], Minpribor and Minelektrotekhprom [Ministry of the Electrical Equipment Industry] have not yet organized serial production of a number of makeup parts for industrial robots--hydraulic and pneumatic equipment, special electric motors, program control systems, different sensors and other products. Industrial robots and manipulators were usually developed for automation of machine building alone, although there are considerably more workers engaged in manual labor in plants other than machine building.

The planning institutes are inadequately studying the capabilities of using industrial robots and manipulators in their sectors and essentially are not providing for introduction of them in designs of new and renovated enterprises.

These are some of the problems with which the new sector is faced. And although approximately 2 years have passed since publication of this article, in the opinion of specialists, little has changed.

Of course, the vigorous measures that have now been undertaken are bearing fruit. In 1982 the journal EKONOMIKA I ORGANIZATSIYA PROMYSHLENNOGO PROIZVODSTVA (EKO) published a diagram that characterizes the growth of the Soviet stock of robots compared with the worldwide level. In 1975, the column "In the USSR" is quite modest alongside the column "In the world"--only 3.1 percent of the total number of robots. Further, "our" column begins to increase gradually: 1976--4.6 percent, 1977--7.6 percent, 1978--14.4 percent; the measures undertaken during the first two phases of robotization began to yield results. More than one-fifth of all world robots were operating in the Soviet Union in 1980 and, according to the estimate of the journal EKO, the figure will be half the total world stock of robots at the end of the five-year plan and it will be 57.1 percent by 1990.

But in the same issue of the journal, three pages after the first, another diagram was placed. This time there were three groups of columns--three in each group.

1980. The smallest column is the volume of robot production planned for this year: 6,000. The column above it is the total applications of ministries: 25,000. And the uppermost column is the calculated need for robots, determined on the basis of preliminary analysis of operators' positions with regard to the entire stock of production equipment which can be serviced by using robots and manipulators: 68,000.

There is still a shortage of robots, we have already said this. But as one can assume, matters will apparently change in the future, there will be more robots and they will begin to be used at enterprises more widely than now.

It was not always so. The forecast for 1985 is as follows: planned output of robots--40,000, robots applied for--60,000 and calculated need--125,000. The forecast for 1990 is: volume of production--100,000, need--120,000, calculated need--375,000.

The increase of production is therefore small. The needs from year to year will be satisfied more and more completely. It is calculated that robots in the same 1990 will release more than 250,000 workers and will save the country approximately one billion rubles. But many more workers--approximately one million--could be replaced and three billion rubles could be saved with proper organization of matters.

The diagram indicates the specific mistrust of robots and of undervaluation of their position in subsequent improvement of production. And one must say that there are some bases for this undervaluation and mistrust.

Complaints that robots are inadequately efficient and that production suffers losses due to introduction of them are alas frequent. And the arguments in favor of robots are hardly convincing: besides an economic effect, they also yield a social effect, replacing workers in hazardous, health-harmful, monotonous or fatiguing operations. Not only are robots expensive, they are also complicated to maintain and operate. The designs of many of them are insufficiently reliable, they fail frequently and they require highly skilled personnel for repair.

A report appeared recently in our press about an outstanding achievement of Japanese engineers and scientists: highly automated plants have been developed where robots manufacture robots: IZVESTIYA correspondent K. Rashidov visited one of the plants--Hino of the Fujitsu FANAK Company. Here is what he wrote:

"Robots produce computers and a mass of the most diverse parts of machines, from which they then assemble robots similar to themselves. True, not entirely without the assistance of people. But within 2-3 years, according to the director, workers will leave the assembly shop. And for now there are only 60 persons here. They monitor the robots. And even so it would be more true to say they help to make this complicated electronic unit, consisting of computers having a unique memory and other rare properties and of efficient robots, the grasping devices of which are amazingly similar to human hands."

The journalist also noted that only one of 100 workers at the plant is on night duty, "supervising" the robots. And during the year a breakdown in operation of a robot at night was noted only once. And that rejects do not exceed 0.03 percent. And that 200 persons are engaged in further scientific and technical development of production. And that the company has organized 206 maintenance centers for the robots produced by it in Japan, without counting such centers in the United States, West Germany, France, England and other countries. All this is undoubtedly significant, important and interesting. But the journalist evaluated all this as some extremely interesting technical experiment or as a demonstration of the enormous capabilities of robots and nothing more.

The specialist is a different matter. Doctor of Economic Sciences, Professor of Leningrad Polytechnical Institute A. Konson writes in an article "Modern Problems of Application of Industrial Robots," published in SOTSIALISTICHESKIY TRUD, about this Japanese plant: "'Robotization' of an entire enterprise yields the greatest saving." And further: "Since the duty personnel and a very small repair team provide service of not only several tens of industrial manipulators but of a large amount of other automatic equipment simultaneously in two and three shifts, there is a very insignificant fraction of wage per robot. The use of robots in serial production together with machine tools with numerical program control in the form of integrated automated systems, controlled by digital computers, yields the greatest economic and social effect. Such systems permit more efficient restructuring of production when changing parts to be machined with minimum expenditures for readjustment."

Despite the somewhat dry exposition, the essence of the problems is clear. Robots are not effective everywhere. And they should be introduced primarily in large complexes--in the form of entire automated shops and plants--rather than at individual workstations and sections. This method is crowned with the greatest success and the greatest economic advantage. Alas, everything is more frequently the opposite with us. The press is filled with reports that "a robot has arrived" at one or another production section. Robots should be sent to plants and associations in primarily large lots rather than singly and rather than in individual detachments. And they should be sent not only to operating plants, where inevitably, upon introducing robots, much must be modified, sometimes in clusters and also perhaps even perhaps mainly to new shops, designed from the very beginning with high level of robotization.

One can understand the desire of specialists of Minpribor and of directors of instrument building enterprises to implement the sector robotization program more rapidly and to develop a new sector. Just as one can understand, for example, the automotive builders, "electronics specialists" and electrical engineers, who are rushing to develop and introduce robots. One can understand their desire to rely primarily on their own intrasector forces. After all, it is still difficult to organize clear intersector ties and to implement large-scale intersector programs. This is also explained by the fact that robots, similar in parameters and designation, are produced in many versions; there is also duplication of design efforts and of the capabilities of plants. Few robots are produced for the time being and each sector tries to meet mainly its own needs and this practice can be regarded as relatively acceptable (although it will undoubtedly result in losses and large ones at that). But generally the time has come to bring order.

The current phase of robotization of industry and of other sectors of the national economy is somewhat similar to the time, remembered by elderly and middle-aged people, when we first began to develop the energy and other natural resources in the country's eastern regions and to construct new cities on the banks of the Siberian rivers on large scales during the first postwar decade. You recall how much enthusiasm there was: "Ah, Bratsk!" or "Ah, Ust-Ilimsk!" Development of these cities was really the exploit of the people and of selfless and even heroic labor. But when the time of enthusiasm had passed, it became clear that these cities are alas uncomfortable, not very pretty and, the main thing, are inefficiently laid out--people are forced to expend much time on travel to the job and home; the operation of the heating runs, water pipelines and other supply lines is very expensive. If only they had thought about this earlier!

This is robot construction. Extensive funds have now been invested in it. Robot designs are being developed which will be delivered to a conveyor and some series will be delivered for a very long time--possibly up to the year 2000. One would not err or miscalculate in correctly and accurately determining the long-term technical policy in the new sector.

The All-Union Scientific Research Institute for Standardization in Machine Building (VNIINMASH) of the State Committee for Standards is located in Moscow. And this institute contains a quite modest, of less than 10 workers, laboratory for standardization and unification of industrial robots, headed by Al'bert Yefimovich Dashevskiy. The collective of this laboratory is performing very important work, principally important for the future of the new sector: it is attempting (and it is attempting, since not everything alas depends on the institute and on the State Standard) to work out and introduce standards--common for all sectors--for robots and also for their assemblies and elements.

The task is an improbably complicated one! After all, having considered a number of designs, one must select the most efficient and effective and frequently on the basis of this selection one must suggest that designers develop one or another assembly, having utilized several progressive engineering solutions in it. And one must then see that the specialists of all

sectors, designing new types of robots, use the engineering solutions common and unified for everyone. The laboratory also conducts seminars--sector and intersector: it teaches the specialist to design robots and to embody in them the most standardized designs. The laboratory and institute are understandably not conducting all the work alone, but together with basic organizations on standardization of industrial robots (they exist at practically all industrial ministries).

The matter is complicated by the fact that the interests of three or five and even 10 sectors must be reduced to a single denominator and the most efficient and rational design, not your own but of your allied worker, must be proved. Nevertheless, there is hope that by the end of the five-year plan it will be possible to standardize and perhaps bring order to the technical parameters and design elements of robots, regardless of the sector that manufactured them.

There is a small demonstration room of the laboratory. There are approximately two tens of robots along the walls. And some, although they are different in dimensions and in the nature of operations performed, have been made from very similar but at the same time generally identical assemblies and elements--modules.

"Robots can be assembled like toys in a children's 'Konstruktor' set, from standard, unitized elements," says A. Ye. Dashevskiy. "There is a total of 50 of these elements. But many versions--literally hundreds of robots, differing in parameters, designation and technical capabilities--can be manufactured on their basis."

The modular principle has enormous advantages. It is sufficient to say that the design and manufacturing period of each new robot is reduced from 2-3 to 3-4 months.

This principle is far from a discovery of VNIINMASH. The Leningrad Scientific Research Institute of Robotics and the same Minpribor are much involved in it. The Smolensk Institute of NIITekhnopribor designed and the Mogilev plant Tekhnopribor organized production of the "PR5-2 device," about which it is said in the catalogue: "This is a unit modular system of hardware for construction of one-, two-, three-, four- and five-degrees of freedom of industrial robots, the total number of modifications of which reaches 425."

There are only five different "cubes"--the "modules" themselves--that are included in the "Konstruktor" set for the engineer-robot builder. And, by assembling them in different combinations, he can offer 425 different robots to the plants!

The modular principle of robot design is the most significant achievement of the last few years and the most important and most efficient path toward technical development of the new sector. It is no accident that the specialists of different sectors of industry during the seminars at VNIINMASH immediately select from the many benches arranged along the walls of the demonstration hall that in which the advantages of the modular principle of robot design are outlined in detail.

This principle is also being introduced abroad--in Japan, Sweden, West Germany and the United States. Production of robots of this type--Pirin--has been organized in Bulgaria. We have also carried out interesting work in this direction. But it is being conducted, alas, in a haphazard manner and again in separate sectors. A unified intersector system of modules is just now being developed.

The rates of robotization of industry throughout the world are vigorous and the process of intensive introduction of robots into almost all sectors of industrial and agricultural production is irreversible. It has been confirmed by practice that automation of production by ordinary, traditional methods permits an increase of labor productivity of workers by 20-70 percent, introduction of robots permits an increase of several fold, while introduction of robot engineering systems permits an increase by an order of magnitude, that is, no less than tenfold. Research is now being conducted on a broad front everywhere and experimental models of so-called "intelligent robots," including those with machine-aided vision, are now being developed. Introduction of them will make it possible to automate, for example, such a complicated, laborious and crucial operation as welding--in shipbuilding and in construction of main gas pipelines.

With regard to the social consequences of robotization of production, they are undoubtedly great, although still difficult to predict.

Thus, the problem of robotization is not so much an engineering problem as a human and social problem. It will introduce many significant correcting factors, for example, in the education system and in personnel training. There is also no doubt that robotization will give birth to new, presently unforeseen occupations, and new principles of organization of labor and production.

COPYRIGHT: Izdatel'stvo "Pravda", "Znamya", 1984.

6521

CSO: 1823/15

END