

NAVAL POSTGRADUATE SCHOOL
Monterey, California



THESIS

**A FUNCTIONAL INTRANET
FOR THE UNITED STATES COAST GUARD UNIT**

by

Robert Todd Hannah

September 1998

Thesis Advisor:
Associate Advisor:

Suresh Sridhar
Carl R. Jones

Approved for public release; distribution is unlimited.

19980824 162



United States Department of the Interior
U.S. Geological Survey

Environmental Management Technical Center
575 Lester Avenue, Onalaska, Wisconsin 54650-8552

IN REPLY REFER TO:

August 19, 1998

Authors
Reviewers
Upper Mississippi River Basin Association
Environmental Management Program Coordinating Committee
Long Term Resource Monitoring Program (LTRMP) Analysis Team
Mississippi River Advisory Group
Science Review Committee
U.S. Geological Survey Science Centers and Regional Offices
Minnesota/Wisconsin Boundary Area Commission
U.S. Army Corps of Engineers

Dear LTRMP Participant:

I am enclosing "1994 Annual Status Report: A Summary of Aquatic Vegetation Monitoring at Selected Locations in Pools 4, 8, 13, and 26 and La Grange Pool of the Upper Mississippi River System" by Sara Rogers, Theresa Blackburn, Heidi Langrehr, John Nelson, and Andrew Spink.

Please contact me at (608) 783-7550, extension 51, if you have questions regarding this report.

Sincerely,

Robert L. Delaney
Center Director

Enclosure:
LTRMP Program Report 98-P009

REPORT DOCUMENTATION PAGE

Form Approved
OMB No. 0704-0188

Public reporting burden for this collection of information is estimated to average 1 hour per response, including the time for reviewing instruction, searching existing data sources, gathering and maintaining the data needed, and completing and reviewing the collection of information. Send comments regarding this burden estimate or any other aspect of this collection of information, including suggestions for reducing this burden, to Washington headquarters Services, Directorate for Information Operations and Reports, 1215 Jefferson Davis Highway, Suite 1204, Arlington, VA 22202-4302, and to the Office of Management and Budget, Paperwork Reduction Project (0704-0188) Washington DC 20503.

1. AGENCY USE ONLY (Leave blank)		2. REPORT DATE September 1998	3. REPORT TYPE AND DATES COVERED Master's Thesis
4. TITLE AND SUBTITLE : A Functional Intranet for the United States Coast Guard Unit			5. FUNDING NUMBERS
6. AUTHOR(S) Hannah, Robert T.			
7. PERFORMING ORGANIZATION NAME(S) AND ADDRESS(ES) Naval Postgraduate School Monterey, CA 93943-5000			8. PERFORMING ORGANIZATION REPORT NUMBER
9. SPONSORING / MONITORING AGENCY NAME(S) AND ADDRESS(ES)			10. SPONSORING / MONITORING AGENCY REPORT NUMBER
11. SUPPLEMENTARY NOTES The views expressed in this thesis are those of the author and do not reflect the official policy or position of the Department of Defense or the U.S. Government.			
12a. DISTRIBUTION / AVAILABILITY STATEMENT Approved for public release; distribution is unlimited.			12b. DISTRIBUTION CODE
13. ABSTRACT (maximum 200 words) This thesis describes the complete development process of a fully functional Intranet for an operational United States Coast Guard (USCG) Electronic Support Unit (ESU) in Alameda, California. The final product is suitable for immediate use. It may also be used as a prototype for future Intranet development efforts. The methodology used to develop a finished, working product provides the core subject matter for this thesis. The discussion concentrates on why certain applications were developed and what benefits they provide. The Intranet was developed in seven unique stages of the Waterfall Model of information systems design. The Waterfall Model traces a systems development lifecycle from planning, to logical design, through physical design, and finally ends with the implementation process. Each stage of the model is addressed in this thesis. Intranet technology provides a radical new means of communicating throughout an organization. This new technology has the potential to change the organization. Elaboration on both the social and technical aspects of introducing an information systems change to the ESU is included.			
14. SUBJECT TERMS Intranet, Information Systems Design, HTML, Active Server Pages, Web Enabled Database, Internet, World Wide Web, Waterfall Model, Rapid Prototyping, Coast Guard, ESU Alameda			15. NUMBER OF PAGES 169
			16. PRICE CODE
17. SECURITY CLASSIFICATION OF REPORT Unclassified	18. SECURITY CLASSIFICATION OF THIS PAGE Unclassified	19. SECURITY CLASSIFICATION OF ABSTRACT Unclassified	20. LIMITATION OF ABSTRACT UL

NSN 7540-01-280-5500

Standard Form 298 (Rev. 2-89)
Prescribed by ANSI Std.

239-18

Approved for public release; distribution is unlimited

**A FUNCTIONAL INTRANET FOR THE
UNITED STATES COAST GUARD UNIT**

Robert Todd Hannah
Lieutenant, United States Coast Guard
B.S., United States Coast Guard Academy, 1991

Submitted in partial fulfillment of the
requirements for the degree of

MASTER OF SCIENCE IN INFORMATION TECHNOLOGY MANAGEMENT

from the

**NAVAL POSTGRADUATE SCHOOL
September 1998**

Author:

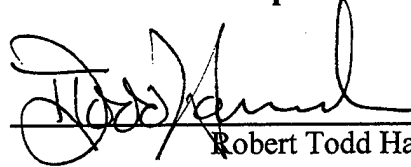

Robert Todd Hannah

Approved by:



Suresh Sridhar, Thesis Advisor



Carl Jones, Associate Advisor

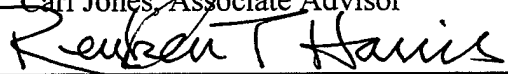

Reuben T. Harris, Chairman
Department of Systems Management

ABSTRACT

This thesis describes the complete development process of a fully functional Intranet for an operational United States Coast Guard (USCG) Electronic Support Unit (ESU) in Alameda, California. The final product is suitable for immediate use. It may also be used as a prototype for future Intranet development efforts.

The methodology used to develop a finished, working product provides the core subject matter for this thesis. The discussion will concentrate on why certain applications were developed, how they are intended to be used, and what business benefits they provide.

The Intranet was developed in seven unique stages of the Waterfall Model of information systems design. The Waterfall Model traces a systems development lifecycle from planning, to logical design, through physical design, and finally ends with the implementation process. Each stage of the development model is addressed in this thesis.

Intranet technology provides a radical new means of communicating throughout an organization. This new technology has the potential to change the organization. Elaboration on both the social and technical aspects of introducing an information systems change to the ESU is included.

TABLE OF CONTENTS

I. BACKGROUND.....	1
A. INTRODUCTION	1
B. CUSTOMER.....	1
C. OBJECTIVE	2
D. INTRANET DEFINED	2
E. INTRANET OBJECTIVE	3
F. METHODOLOGY	3
G. INTRANET DESIGN AND APPLICATION FEATURES.....	4
H. INTRANET IMPLEMENTATION.....	5
I. CONTENTS.....	5
II. INTRANET	9
A. INTRODUCTION	9
B. INTRANET DEFINED	9
C. INTRANET BENEFITS.....	10
D. INTRANET SCOPE.....	12
E. HOW INTRANETS WORK.....	13
1. Client-Server Model.....	13
2. Network.....	14
3. Static and Dynamic Web Pages	14
F. INTRANET APPLICATIONS	15
1. Web browser as Application Interface.....	15
2. Other TCP/IP Applications.....	16
3. ESU Intranet Applications	16
G. CONCLUSION.....	16
III. LIMITATIONS AND ASSUMPTIONS.....	19
A. INTRODUCTION	19
B. INTRANET DEVELOPMENT ASSUMPTIONS	19
1. Introduction.....	19
2. Qualifications.....	19
3. Coast Guard Perspective	20
4. Remote Development Site	20
5. Resource Constraints	21
6. Assumptions.....	22
7. Technical Ability Bias	22
8. Time Constraint	23
C. CONCLUSION.....	23
IV. METHODOLOGY.....	25
A. INTRODUCTION	25
B. WATERFALL MODEL DEFINED	26
C. WATERFALL MODEL APPLIED.....	28
1. Project Identification and Selection.....	28
2. Project Initiation and Planning.....	29
3. Analysis.....	30

4. Logical Design	30
5. Physical Design.....	31
6. Implementation	32
7. Maintenance.....	32
D. RAPID PROTOTYPE METHOD	33
E. CONCLUSION.....	35
V. ANALYSIS	37
A. INTRODUCTION	37
B. PROCESS ANALYSIS METHOD	37
1. Systems Perspective.....	37
2. Method	38
C. ESU ALAMEDA BUSINESS MODEL	42
1. Overview.....	42
2. ESU Customers.....	42
3. Organization.....	43
4. Information Flows.....	44
5. Business Model Analysis.....	44
D. CRITERIA FOR SELECTION OF INTRANET SOLUTIONS	45
1. Command's Top Goals	45
2. Feasibility.....	46
3. Showcase Intranet Potential	46
E. LOGICAL DESIGN	47
1. Requirements Analysis	47
2. Data Flow Diagrams	47
3. Desired Functionality.....	50
4. Functional Partitioning	50
F. CONCLUSION.....	51
VI. SOFTWARE TOOLS	53
A. INTRODUCTION	53
B. SOFTWARE TOOLS	53
1. General Selection.....	53
2. Web Browser	54
3. Web Page Authoring and Web Site Management	55
4. Databases	56
5. Middleware	56
6. Internet Web Server	58
C. CONCLUSION.....	58
VII. PHYSICAL DESIGN	59
A. INTRODUCTION	59
B. PHYSICAL DESIGN STEPS.....	59
1. Web Server.....	59
2. Web Authoring Tools	59
3. Middleware	60
4. Database.....	60
5. Data Source Name (DSN).....	60

- 6. Intranet 60
- C. CONNECTING TO A DATABASE WITH ASP 61
 - 1. Introduction..... 61
 - 2. Database..... 61
 - 3. ODBC and the Data Source Name..... 62
 - 4. Connection Object 62
 - 5. Recordset Object..... 63
 - 6. Define SQL 63
 - 7. Execute the Query 63
 - 8. Display the Results 63
- D. GRAPHIC USER INTERFACE DESIGN PRINCIPLES..... 64
 - 1. Introduction..... 64
 - 2. Consistency 65
 - 3. Current Content..... 65
 - 4. Usability 66
 - 5. Deletions 66
 - 6. Site Navigation and Menu Bars 67
- E. SECURITY FEATURES..... 68
 - 1. How to Use the Security Features:..... 68
 - 2. Security Policy Considerations:..... 69
 - 3. How Security Works:..... 71
- F. CONCLUSION..... 72
- VIII. APPLICATIONS..... 73**
 - A. INTRODUCTION 73
 - B. APPLICATION NAVIGATION STRUCTURE..... 73
 - C. HOME PAGE 75
 - D. PERSONNEL APPLICATION 76
 - 1. Introduction..... 76
 - 2. Web Pages of the Personnel Application..... 76
 - E. LEAVE APPLICATION 84
 - 1. Introduction..... 84
 - 2. Web Pages of the Leave Application..... 84
 - F. TAD APPLICATION 92
 - 1. Introduction..... 92
 - 2. Web Pages of the TAD Application 92
 - G. ANNOUNCEMENTS APPLICATION 96
 - 1. Introduction..... 96
 - 2. Web Pages of the Announcements Application..... 96
 - H. PERSONNEL REPORTS APPLICATION..... 100
 - 1. Introduction..... 100
 - 2. Web Pages of the Personnel Reports Application 100
 - I. SUPPLY APPLICATION 108
 - 1. Introduction..... 108
 - 2. Web Pages of the Supply Application 109
 - J. SECURITY APPLICATION 117

1. Introduction.....	117
2. Web Pages of the Security Application	117
K. CONCLUSION.....	120
IX. IMPLEMENTATION.....	121
A. INTRODUCTION	121
B. IMPLEMENTATION.....	122
C. STRATEGIES FOR CHANGE.....	124
1. Introduction.....	124
2. Change Formula.....	125
3. Systems Loops	129
D. PHYSICAL INSTALLATION.....	130
E. CONCLUSION.....	131
X. CONCLUSION.....	133
APPENDIX A. ASP APPLICATION - DESIGN AND CODE.....	135
A. INTRODUCTION	135
B. FRONT PAGE 98 VISUAL DEVELOPMENT ENVIRONMENT OF ANNOUNCEMENTS_FORM.ASP.....	136
C. HTML CODE OF ANNOUNCEMENTS_FORM.ASP	140
D. CONCLUSION.....	144
APPENDIX B. GLOSSARY OF TERMS	145
LIST OF REFERENCES.....	149
BIBLIOGRAPHY	151
INITIAL DISTRIBUTION LIST	153

LIST OF FIGURES

Figure 2.1 Intranet Benefits and Challenges from (CIO Insider)	10
Figure 2.2 Client-Server Model	13
Figure 4.1 Waterfall Model of the Systems Development Lifecycle	26
Figure 4.2 Stages of Waterfall Model and Thesis Chapters	28
Figure 4.3 Iterative Development using the Rapid Prototyping Process	34
Figure 5.1 Original Process Interview Questionnaire	39
Figure 5.2 DFD of Supply and Parts Ordering Business Process	41
Figure 5.3 ESU Alameda Organization	43
Figure 5.4 ESU Alameda Business Model Chart.....	45
Figure 5.5 Level 0 DFD for Entering Intranet	48
Figure 5.6 Level 1 DFD for Intranet.....	48
Figure 5.7 Level 2 DFD of Supply Application	49
Figure 5. 8 Logical Applications with Criteria for Selection.....	50
Figure 5.9 Functional Decomposition Diagram of ESU Intranet	51
Figure 6.1 Software Tools Chosen for Intranet Development	54
Figure 7.1 Person Table of Phonebook Database	61
Figure 7.2 ODBC System DSN Setup Window	62
Figure 8.1 Intranet Navigation Structure	74
Figure 8.2 ESU Alameda Intranet Home Page	75
Figure 8.3 Personnel Administration Application Navigation Structure.....	76
Figure 8.4 Table of Web Pages and Corresponding Figures	76
Figure 8.5 Personnel Administration Welcome Page	77
Figure 8.6 Personnel Details	78
Figure 8.7 Edit Personnel Details	79
Figure 8.8 Add New Personnel On-line Form	80
Figure 8.9 Successful Update to Database.....	81
Figure 8.10 Warning Box for Deleting Records	82
Figure 8.11 Delete a Record	82
Figure 8.12 Leave Admin Application Navigation Structure	84
Figure 8.13 Table of Web Pages and Corresponding Figures	84
Figure 8.14 Home Page with Leave Application Highlighted.....	85
Figure 8.15 On-line Leave Request Form.....	86
Figure 8.16 Leave Approval Chain.....	87
Figure 8.17 Status of all Pending Leave Requests.....	88
Figure 8.18 Summary of Current and Upcoming Leave.....	89
Figure 8.19 Details of a Leave Request	90
Figure 8.20 Past Leave Archive	91
Figure 8.21 TAD Application Navigation Structure.....	92

Figure 8.22 Table of Web Pages and Corresponding Figures	92
Figure 8.23 Home Page with TAD Application Highlighted	93
Figure 8.24 On-line TAD Notification Form.....	94
Figure 8.25 Summary of TAD Information.....	95
Figure 8.26 Announcement Application Navigation Structure	96
Figure 8.27 Table of Web Pages and Corresponding Figures	96
Figure 8.28 Home Page with Announcements Application Highlighted	97
Figure 8.29 Announcement Details	98
Figure 8.30 On-line Announcement Form.....	99
Figure 8.31 Personnel Reports Application Navigation Structure.....	100
Figure 8.32 Table of Web Pages and Corresponding Figures	100
Figure 8.33 Recall Log	101
Figure 8.34 Department Phonebook	102
Figure 8.35 Alphabetical Phonebook.....	103
Figure 8.36 Marks Due this Month.....	104
Figure 8.37 Status of All Marks Due	105
Figure 8.38 Complete Marks Schedule.....	106
Figure 8.39 Edit Marks Schedule.....	107
Figure 8.40 Supply Application Navigation Structure	108
Figure 8.41 Table of Web Pages and Corresponding Figures	109
Figure 8.42 Supply Database Home Page.....	110
Figure 8.43 On-line Purchase Request – Part 1	111
Figure 8.44 On-line Purchase Request – Part 2	112
Figure 8.45 Complete Purchase Request	113
Figure 8.46 Warning About Assigning PR Numbers	114
Figure 8.47 Storekeeper Form to Assign PR Number	114
Figure 8.48 Status Log Update Form.....	115
Figure 8.49 Order Marked as Received	116
Figure 8.50 Table of Web Pages and Corresponding Figures	117
Figure 8.51 Home Page with Security Application Highlighted	118
Figure 8.52 Successful Login	119
Figure 8.53 Unsuccessful Login	119
Figure 8.54 Access Denied	119
Figure 9.1 Spectrum of Possible Implementation Outcomes.....	123
Figure 9.2 Limits to Growth System Loop of Intranet Implementation.....	130
Figure A.1 View of Intranet in Front Page 98 Explorer	136
Figure A.2 Announcements Form in FP98 Editor (Part 1).....	137
Figure A.3 Announcements Form in FP98 Editor (Part 2).....	138
Figure A.4 Announcements Form in FP98 Editor (Part 3).....	139

ACKNOWLEDGMENT

I thank my wife Leesa for her generous love. She has endured many lost weekends and late nights without seeing me over the course of this project. I also thank my two beautiful daughters, Annalise and Sophie Rose, who are my inspiration.

I. BACKGROUND

A. INTRODUCTION

This thesis describes the complete development process of a fully functional Intranet for an operational United States Coast Guard (USCG) Electronic Support Unit (ESU) in Alameda, California. The final product may be used as an operational Intranet for the ESU, or it may simply be a prototype, which can be used as a baseline for future development efforts.

The Intranet was developed in seven unique stages of the Waterfall Model of information systems design. The Waterfall Model traces a systems development lifecycle from planning, to logical design, through physical design, and finally ends with the implementation process. Each stage of the development model is addressed in this thesis.

The development effort resulted in a complete physical product, which will be delivered to the customer. The discussion will concentrate on how and why certain applications were developed, how they are intended to be used, and what business benefits they provide. Both the management aspects and the technical solutions for the Intranet will be addressed.

Intranet technology provides a radical new means of communicating throughout an organization. The product of this thesis is a well designed and technically solid, Intranet tool with significant potential to enhance, improve and eliminate current ESU business processes. This new technology has the potential to change the organization.

The final success or failure of the implementation does not depend solely on the technical merits of the system. Instead, the social aspects of introducing a powerful new information system to an organization must be considered. The way the change is managed will determine the final outcome of the implementation process. The results of the new change will not be known for some time.

B. CUSTOMER

The sponsoring Command was United States Coast Guard Electronic Support Unit Alameda (ESU). ESU Alameda's mission is to provide support and maintenance

resources for all electronics, telecommunications and computer equipment aboard USCG units in the Eleventh Coast Guard District. The Eleventh District encompasses the entire State of California as well as any USCG units requesting assistance while in California waters. The ESU has a central office located in Alameda, California where there are about 50 full time employees. ESU Alameda also has three remote ESU Detachments which are located in San Pedro, San Diego and Oxnard, California.

C. OBJECTIVE

The thesis objective is to build a functional prototype Intranet. The customer may find many different ways of using it. The possible outcomes from the implementation process are listed here in order of increasing success. First, the Intranet may be considered solely as a prototype, which demonstrates the capabilities of Intranet technologies. In this case, it would rarely be used in daily operations. Next, the Intranet may actually be integrated and used in the ESU's daily operations as a fully functional tool. Finally, it may be both an operational tool as well as a prototype that is maintained and enhanced at the ESU. This foundation of an Intranet may grow larger over time as the ESU takes ownership of it. This is the ideal goal.

In all cases, the ESU will benefit from this thesis. Their Intranet is custom built with over 80 dynamically generated pages. A commercial Web site costs a minimum of \$1000 for a basic site, designed from template, with a maximum of 20 static pages (www.Interland.net). The ESU Intranet is essentially free. Even if the Intranet implementation fails over the long term, the ESU will have had a working prototype to test. This will give them an advantage on any future Intranet requirements determination cycle. They will have had a more comprehensive understanding of their own needs and the capabilities of the technology.

D. INTRANET DEFINED

An Intranet is simply a private version of the Internet. Intranets conveniently make internal company information available to all employees using the same protocols and technologies that make the World Wide Web so successful. Where the Internet is

global in reach, an Intranet is private and usually access is either physically or virtually restricted to a particular company's members. An Intranet opens the channels of communication to allow sharing, updating and querying for information throughout the network without regard to time or distance.

The minimum requirements for an Intranet include a local area network, a Web Server, Web browsers, and Web authoring tools. Intranet information is typically displayed on Web pages in a client terminal's Web browser window.

E. INTRANET OBJECTIVE

The objective of the Intranet is to provide a technology tool that will add value to the ESU's daily operations. The Intranet is a tool that should be incorporated into a broader organizational management plan.

The goal of the developer was to address the Command's top needs with Intranet solutions. Analysis of the ESU's business model uncovered many business processes, which could benefit from Intranet technologies. Choices had to be made about which applications were most feasible and which would actually be developed for the ESU Intranet. Availability of technology, the author's expertise, and time constraints were limiting factors that narrowed the scope of applications development. The final product successfully addresses aspects of two major concerns of the ESU Command, personnel administration and supply tracking. Other business benefits, such as remote availability of up-to-the minute dynamic information and enhanced communications across the organization, were also realized.

F. METHODOLOGY

The goals of the project were both to develop an actual working product and to design a prototype that demonstrates the capabilities of the technology. The Waterfall Model or Systems Development Lifecycle (SDLC), with its process of clearly defined steps, was used to develop the working Intranet product. The Waterfall Model approach was helpful in structuring the development progress from requirements analysis at the start until final implementation at the ESU by the end.

G. INTRANET DESIGN AND APPLICATION FEATURES

The project design incorporates two partitions labeled "Intranet" and "Extranet". "Intranet" information is protected by security access levels and authorized users are specifically limited to ESU employees use only. "Intranet" information includes access to personnel and supply databases and the ability to execute Intranet applications that take their data from those databases. "Extranet" information is available to anyone who is on the Coast Guard Data Network Web (CGWEB). The CGWEB, as defined in USCG Commandant Instruction 5230.57, uses Internet technology inside the USCG security perimeter (users behind USCG firewalls) to provide a "private Internet". ESU "Extranet" information includes a phone and e-mail directory, access to other ESU Alameda department Web sites, and the daily list of who is on leave or away for temporary duty.

Security is implemented on a page by page basis. When a page is requested, the security access level is checked and access is granted or denied based on the access level the user has logged in at.

On-line form processing is a significant application feature on the Intranet. Forms that were once filed and routed through office inboxes and outboxes can now be instantaneously routed through virtual inboxes and outboxes. The form data is automatically stored in databases. This provides new ways to query and manipulate data that was once only stored in filing cabinets or not at all.

The site design is generic enough to be installed at other Coast Guard units. Once ESU Alameda tests the Intranet and fine tunes it, it could possibly be deployed to other local commands, to other ESU's or any other Coast Guard units.

The Leave, Temporary Assigned Duty (TAD), and Recall Log are three applications that support the ESU's priority of keeping better track of personnel. The Marks Application supports the Command's goal of forecasting when personnel marks are due. The Supply Application introduces on-line form processing and status updates for Purchase Requests. This supports the ESU's interest in improving the supply ordering processes. The Announcements Application facilitates better communications throughout the ESU. The Phonebook Application provides "Extranet" visitors with up-to-date phone numbers and email addresses.

H. INTRANET IMPLEMENTATION

The Intranet will be installed at the ESU during the summer of 1998. There are many issues of managing social and technical change which could affect the complete adoption of a new tool like an Intranet.

In order for the ESU to take ownership for and maintain their new Intranet site, both the management solutions and the technical solutions must be addressed during implementation. From the business perspective, the ESU will have to write their own policy on Intranet use to include guidance on security, acceptable use instructions and backups. Recommendations on change management, or how to introduce a new information system to an organization, were included as part of this thesis. Technical details of the Intranet were included in this thesis as well.

I. CONTENTS

This section contains a brief summary of the thesis chapters.

1. Chapter I. Background

This chapter introduces the thesis topic, customer and a brief definition and discussion of the Intranet, its applications and implementation issues.

2. Chapter II. Intranet

This chapter introduces terms used throughout the thesis. Discussion in this chapter focuses on what an Intranet is, how it can affect an organization, and the technical requirements for implementing one.

3. Chapter III. Limitations and Assumptions

This chapter describes the limitations and assumptions that affected decisions about what Intranet applications were actually developed for the ESU.

4. Chapter IV. Methodology

The Intranet development and design methodology is described in this chapter. The stages of the Waterfall Model are defined here. Discussion of how each stage was conducted is presented in this chapter. The Rapid Prototyping model is also defined here.

5. Chapter V. Analysis

Analysis of ESU Alameda's business model is covered in this chapter. The criteria for selection of business processes for Intranet solutions are described here. These criteria drove Intranet development. The chapter finishes with a logical design of an ESU Intranet.

6. Chapter VI. Software Tools

This chapter identifies what software tools were used for developing the Intranet. The reasons why these tools were chosen are explained here.

7. Chapter VII. Physical Design

A brief tutorial of how to physically build an Intranet is provided in this chapter. The guiding principles, such as the Graphic User Interface, behind hundreds of hours of code and development effort are discussed in this chapter.

8. Chapter VIII. The Applications

The applications are the final products from the physical design phase. This chapter details each specific Intranet application and how it is meant to be used. Screen shots of each relevant Web page of the applications are included.

9. Chapter IX. Implementation

This chapter covers implementation primarily from a management perspective. The idea that it is the social aspect, not solely the technical, that determines the outcome of an information systems change in an organization is discussed in this chapter. An organizational change formula is also presented here.

10. Chapter X. Conclusion

This chapter contains the conclusion. A look to the future for further development ideas and lessons learned are also presented here.

11. Appendix A: ASP Application Design and Code

The appendix contains a short explanation of how Active Server Pages were used to implement the Announcements Application on the Intranet. The on-line announcements form queries the user for information, updates the database, and displays a result. These interactions are typical and found in most of the applications across the

Intranet. The HTML, Visual Basic Script and ASP code listings are presented in both a visual context as well as textual.

12. Appendix B: Glossary of Terms

This glossary is reprinted from various on-line services. It provides the thesis reader with the definitions of some of the technical terms used throughout the thesis.

13. Enclosures

The source code for the thesis is contained on a CD-ROM disk. This disk contains a folder named "prototype2" with all the Web pages of the Intranet site. This folder may be copied to the WWWROOT directory of any Windows Internet Information Server, running Active Server Pages, for an instant Intranet. A "ReadMe" file is included to address the specifics of installation. The disk contains three Access databases named "phonebook", "supply", and "announcements". The text of this thesis is also on the CD-ROM. (Note that this CD-ROM is not included with all copies of this thesis. It can be checked out from the Dudley Knox Library at NPS.)

II. INTRANET

A. INTRODUCTION

An Intranet opens the channels of communication to allow sharing, updating and querying for information throughout the network without regard to time or distance. This chapter briefly defines what an Intranet is, what benefits may result from having one, and how it works. Discussion of the ESU Intranet is also included here.

B. INTRANET DEFINED

An Intranet adapts the technologies used on the World Wide Web for use on an internal network. In essence, it is a private Internet. An Intranet uses a client-server model. This means it is run from a central Web server with client computers accessing it through Web browsers.

The reference to "ESU Intranet" throughout the thesis primarily refers to the actual Web pages the end-user sees in their Web browser window. In reality, the scope of the ESU Intranet is broader and it includes all the underlying components and code necessary to run the client-server Intranet site. When a client computer makes a request on the Intranet, these components allow back-end databases to feed data to the Web server. The Web server then dynamically generates Web pages, from the results of the database query, and outputs the pages to client Web browser that made the request.

To develop and maintain an Intranet, the minimum requirements include a Transmission Control Protocol/Internet Protocol Local Area Network (TCP/IP LAN), a

Web server, Web browsers, and Web authoring tools. Intranet information is typically displayed on Web pages in a client terminal's Web browser window.

C. INTRANET BENEFITS

There are numerous benefits to an Intranet. The essence of it is that more information is available to more people in a common, accessible format. An Intranet is

“... a TCP/IP network inside a company that links the people and information in a way that makes people more productive, information more accessible, and navigation through all the resources and applications more seamless than ever before.” (p.57, Burleson, 1994)

The Benefits

- distributed access to wide range of information and services

- increased platform independence
- enterprise information sharing
- information provided in context
- historical/over time sharing
- easier interaction with experts

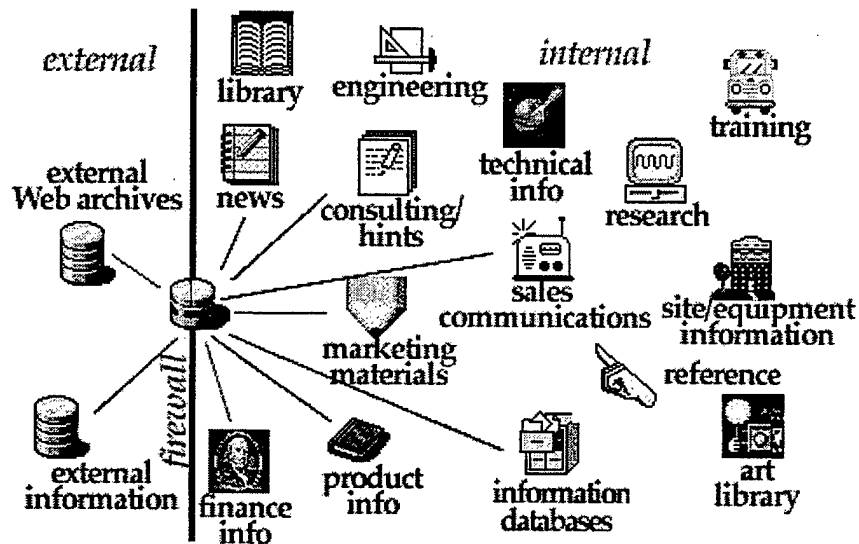

Figure 2.1 Intranet Benefits and Challenges (CIO Insider)

These common applications usually are the first to be implemented on a new Intranet. Initially, they tend to demonstrate the capabilities of the new technology and

often have an immediate and dramatic impact on the organization. The applications include:

- phone directories
- employee information
- company policies
- product information
- training information

Other powerful applications include:

- database interactions
- groupware
- knowledge capture
- decision support

Remote access to the Intranet is possible through a common, platform independent, interface. Platform independence means that even clients running different operating systems on different kinds of computers can access the Intranet. For example, an Intranet that is hosted on an Intel Pentium-based computer running Microsoft NT Internet Information Server can be accessed by Sun Solaris UNIX-based computers or even Macintosh clients. Any computer capable of running a Web browser, that has a connection to the Intranet network, can access the Intranet and its Web enabled databases. The Web browser takes the place of a traditional application specific interface.

These and other Web-enabled applications have the power to change an entire organizational environment by “making information, once buried in hundreds of places in the organization, available to everyone” (pp. 15-16, Burleson, 1994).

D. INTRANET SCOPE

An Intranet’s scalability is virtually unlimited since it uses the same technologies that make the global World Wide Web possible. One of the most powerful features of an Intranet is access to enterprise-wide information without regard to time or distance. The term “enterprise” means the entire organization. For example, the Ford Motor Company Intranet could provide employee benefits information to all of its employees worldwide through an enterprise wide Intranet.

The U.S. Coast Guard is the enterprise with regard to the ESU Alameda Intranet. The USCG enterprise wide Intranet is currently under construction on the Coast Guard Data Network Web (CGWEB). The CGWEB, as defined in USCG Commandant Instruction 5230.57, uses Internet technology inside the USCG security perimeter (users behind USCG firewalls) to provide a “private Internet”.

Any USCG employee who has access to the CGWEB will be able to access the ESU Alameda Intranet. This gives the ESU the power to update its own information, such as its phone directory, and the change is immediately reflected and available throughout the enterprise.

Not all Intranet information is appropriate for enterprise wide distribution. Payroll or financial data, for example, should not be distributed as widely as phone directory information. An Intranet typically will have internal and external customers.

The ESU Intranet is modeled with two distinct Intranet areas. Information posted on the ESU "Extranet" is available enterprise wide to anyone with access to the CGWEB. The ESU "Intranet" data is only available to ESU employees and access requires a login and password check.

E. HOW INTRANETS WORK

1. Client-Server Model

The client-server model is very simple. One computer on a network, the server, acts as a central processor for a group of client computers. The server is dedicated to responding to requests from client computers. For example, an application server would host a shared application, such as a word processing program, which could then be executed on any client computer on the network.

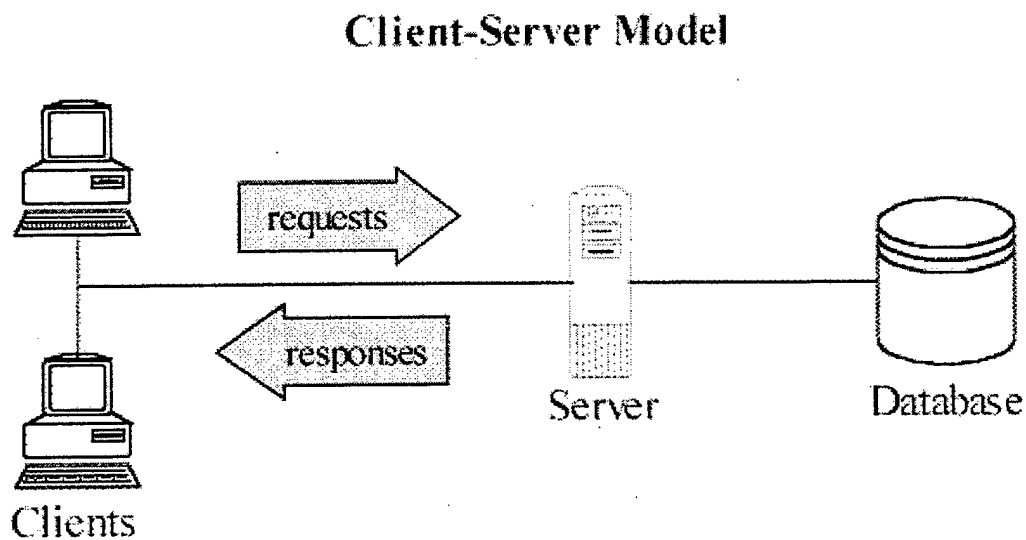

Figure 2.2 Client-Server Model

A Web browser and Web server emulate the client-server information systems model. The Web server on the ESU Intranet responds to requests from clients by

querying its databases and then dynamically generating Web page code. The Web server returns the code to the client's Web browser window.

The ESU Intranet client-server models work with a middleware component that facilitates the interaction of the databases with the Web browser. The Web server hosts the Intranet site by generating and serving HTML code to the client Web browsers upon request. The database holds all the relevant data for Intranet applications.

2. Network

The ability to have an Intranet depends on having computers that can communicate with each other. If two computers want to exchange data, they must speak the same language. Transmission Control Protocol/Internet Protocol (TCP/IP) is the protocol, or common network language, that allows computers to exchange data. There are other protocols available, but TCP/IP is the one used to transmit data across the Internet. It is such a versatile language that data can be sent from one computer, routed over the Internet, and arrives across the globe just as it was sent.

3. Static and Dynamic Web Pages

Typical Web pages are static documents, which means that they do not change. Static pages are written once and served to the client's Web browser in Hypertext Markup Language (HTML) code. For example, a Web page that contains the text of the Constitution of the United States would be static because the HTML code could be written once and then never (or rarely) need to be changed.

Most of the Web pages on the ESU Intranet are different because the pages are dynamic. The HTML code for a dynamic Web page is individually recreated on the Web server every time a client browser requests a page. This is called "server side scripting" because the server rewrites every HTML page at the server before passing it to the client. For example, a Web page that displays the results of an Web search on the keyword "constitution" would be dynamic because the Web server would have to generate a new and unique response, in HTML for the client, specifically on that keyword search.

F. INTRANET APPLICATIONS

1. Web browser as Application Interface

The traditional view of an application is that it is a standalone program that is launched with its own uniquely developed human to computer interface. With a Web enabled Intranet application, the user can navigate through an application with a customized interface created for the Web browser. While there are certainly limitations with what one can accomplish visually in a Web browser window, there is a huge benefit in that every single Web-enabled application can be launched through the same human to computer interface window.

For example, in a traditional Microsoft Access database application, the user navigates the database through either the default Access interface or a customized interface created by the developer from within Access. Either way, the user is still running the database through the Access application program. The Intranet view of the

application is always through the Web browser. In fact, on the Intranet the Access application program is never launched or even seen by the user.

2. Other TCP/IP Applications

Applications and other protocols “ride” on top of TCP/IP. Although the Web browser, which uses the HyperText Transport Protocol (HTTP), is the most common Intranet application, any program that can use TCP/IP can be implemented across an Intranet network. Other useful applications include e-mail and video teleconferencing.

3. ESU Intranet Applications

Applications on the ESU Intranet are defined as groups of interrelated, dynamic Web pages that interact with a back-end database. The Web browser window is the standard interface for all ESU Intranet applications.

G. CONCLUSION

An Intranet is a powerful tool that is reshaping the way people communicate throughout the enterprise. It has tangible benefits, it is fairly easy to deploy, and just as the Internet’s growth is seemingly unlimited, an Intranet’s scalability is virtually unrestricted. There are also countless challenges, such as maintaining current content, and consequences, such as changing existing business processes, of using this new technology.

The rest of this thesis will explore these challenges and consequences of turning the idea of an Intranet into a reality for a mid-sized USCG unit. Designing the product,

aligning the technology with the unit's business goals, and successfully introducing a change will be covered.

III. LIMITATIONS AND ASSUMPTIONS

A. INTRODUCTION

The author faced limitations of competency and technical skill and made assumptions for this project. Choices, which affected the ultimate design of the system, were governed, in part, by these factors so discussion of them is warranted.

B. INTRANET DEVELOPMENT ASSUMPTIONS

1. Introduction

The focus of this thesis is on the complete process of Intranet systems development. This thesis concludes with an actual physical product that is ready for operational testing and daily use.

2. Qualifications

The scope of thesis had to be narrowed to a practical and attainable goal. This means that choices had to be made about which processes would be modeled and what priority they would take. The abilities of the author were a significant factor in which choices were made for the final product. For that reason, some discussion of what those abilities are and how they were acquired is relevant.

Qualifications to undertake this project were acquired over eighteen months of classroom instruction and self-study in the Naval Postgraduate School's Information Technology Management curriculum. The curriculum covers many methodologies and theories of the logical process of information systems analysis, design, development and

implementation. The management aspects of introducing information system change to an organization are also covered in this curriculum.

The technical aspects of developing code and choosing appropriate software tools for the physical design of the Intranet were mainly learned through self-study. The tools and applications that were learned during the four-month development phase included various Web site design tools, database applications, Internet servers, middleware, Visual Basic script and JavaScript programming languages. A method for learning these tools included consulting many books, tutorials, on-line guides, trade journals, Internet resources and resorting to serendipitous trial and error. A proficiency, but not expertise, in all of the critical areas was attained.

3. Coast Guard Perspective

Being a United States Coast Guard officer, the author had relevant experience, which provided a foundation for analyzing the needs and processes of a USCG unit. This USCG background had natural advantages for requirements analysis. It also led to some assumptions of how a USCG unit should look. A USCG consultant working for a USCG customer does face the danger of simply automating existing business processes instead of re-thinking them in fresh new ways. The author was conscious of this possible bias.

4. Remote Development Site

Although there was a comprehensive analysis of the ESU's business model, the Intranet developer will not use the ESU Intranet on a day to day basis. The Intranet was not created on site in the true ESU Alameda working environment. Instead, it was

developed remotely at Naval Postgraduate School. This offered the advantage of a fresh perspective. There is, however, a danger that some aspects of the ESU business model were missed which may affect the chances of long term Intranet success.

5. Resource Constraints

Naval Postgraduate School, not the thesis customer, provided almost all of the resources necessary to complete the project. These resources included access to a Windows NT server class computer, a dedicated Internet Protocol address registered with the InterNic Domain Name Service as "cg.nps.navy.mil", and various software development tools.

Money played a role in the selection of software development tools. The sponsor had limited funds and only agreed to pay for a few days of thesis travel and one technical book. The sponsor purchased one \$50 software component which was required, but was unwilling to spend a significant amount of money for new, non-Coast Guard standard software for a research project. A primary criterion for selection of software tools was therefore price and academic availability.

Since the science of and tools for Intranet development are relatively new, there are few books and references in the NPS library. Most of the books and relevant reference material had to be purchased or looked up on-line over the Internet. Technical books on Intranets and software generally cost \$60 to \$100. Aside from the one technical book the customer purchased, all other relevant technical books were borrowed from NPS or purchased individually. This constraint meant the developer was highly selective in

which tools to attempt to learn. Buying the books to learn too many different software tools was prohibitively expensive.

6. Assumptions

Assumptions made for this project affected the development and outcome of it in various degrees. A brief list of these assumptions follows.

The biggest assumption was that ESU Alameda actually wanted a new Intranet developed as part of an NPS thesis. The Intranet idea was proposed from the author to the customer, not the other way around. Also, it was assumed that the thesis would not be funded to the degree of other projects whose sponsors have specific research goals or agendas. Since the Intranet proposal did not come from within the ESU, it was assumed that some employees of the unit would resist the change the new Intranet introduces.

A belief that Intranet technologies could improve, enhance or re-engineer existing aspects of the ESU Alameda business model was also presupposed. Finally, it was assumed that the project was feasible. There was a faith that acquiring the technical skills and qualifications to see the project through to completion was possible.

7. Technical Ability Bias

The lack of a comprehensive technical expertise may have introduced bias into the selection of business process Intranet applications to develop and the software tools to design with. Inexperience may have prevented an entirely critical evaluation of the variety of Intranet software development tools available. A bias towards picking

software tools that were the easiest to use and learn, and a tendency to choosing the least complex business processes for application design, occurred in this project.

8. Time Constraint

Ideally, the author would have liked to create a more comprehensive Intranet site for the customer. The site would contain more applications for more Web enabled business processes. There would be rich content organized by knowledge area, more decision support tools would be available and easy content development applications would be used on the Intranet to empower all members of the organization to communicate in new ways. In reality, the most significant constraint that stood in the way of such a comprehensive effort was that there simply was not enough time.

C. CONCLUSION

Despite these biases, constraints, and assumptions, the final product works and meets many of the ESU's goals and needs. This Intranet may yet be the seed of a new USCG information system, which could grow into a much larger implementation, as the customer discovers its power and utility.

IV. METHODOLOGY

A. INTRODUCTION

A methodology is a “comprehensive, multi-step approach to systems development” (p.8, Hoffer, George, Valacich, 1996). The development methodology of the ESU Intranet project was the Waterfall Model. Aspects of the Rapid Prototyping approach were also used to physically design the product.

The Waterfall Model, otherwise known as the Systems Development Lifecycle (SDLC), is a relatively formal process of clearly defined steps, which occur discretely one after another. The Waterfall Model is typically used to develop large-scale information systems.

Rapid Prototyping sometimes referred to as Rapid Application Design (RAD), is a much less formal method of iterative development. RAD is intended to quickly develop a prototype that can either become immediately operational or redesigned later using a more comprehensive formal approach.

The first goal of this project was to develop an actual working Intranet product. The Waterfall Model was used as the complete lifecycle model for development from beginning to end. The Waterfall Model provides a comprehensive framework for information systems development from requirements analysis at the outset until a final implementation by the close.

A second goal of the project was to develop a prototype that demonstrates the capabilities of the technology. The final product can actually be regarded as one phase of

a Rapid Prototype iterative design loop. From this perspective, the Intranet is never really completed. Following the initial installation, it is continuously improved and refined locally by the client.

B. WATERFALL MODEL DEFINED

The Waterfall Model is a multi-stage, comprehensive methodology with seven clearly defined steps. The approach uses a formal process to systems design that reduces the probability of bugs in the design. With its emphasis on proper requirements analysis at the beginning and on proper implementation and maintenance at the end, it widens the development perspective to include more than just a focus on writing computer code.

The seven stages, as described in the textbook Modern Systems Analysis and Design (p.24, Hoffer, George, Valacich, 1996), are presented below.

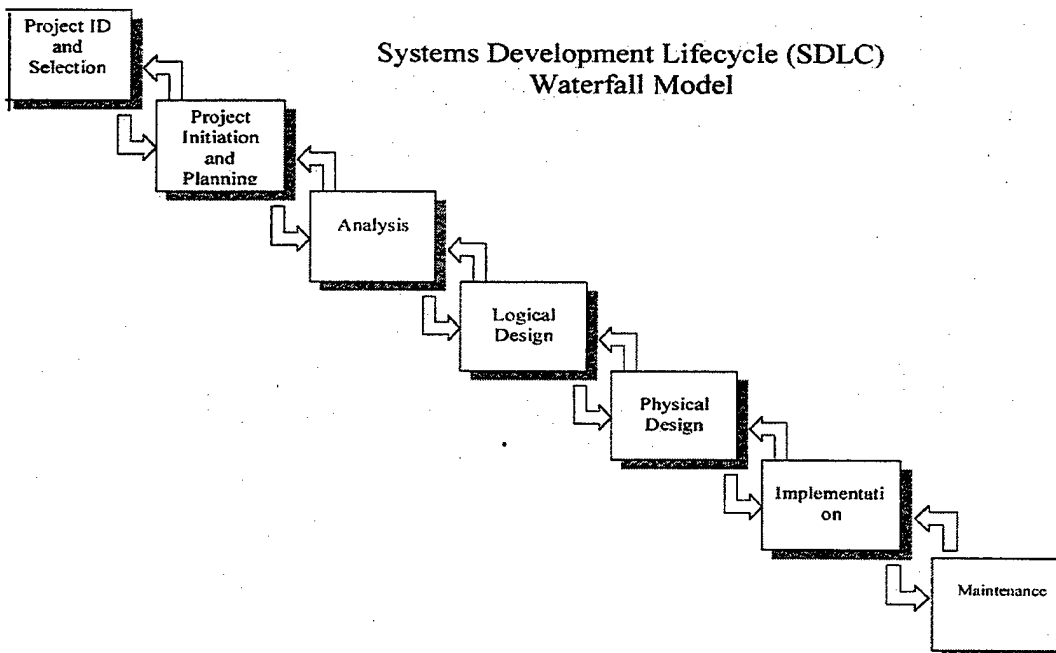

Figure 4.1 Waterfall Model of the Systems Development Lifecycle

The Waterfall Model is an excellent choice for a structured development effort conducted in discrete phases. The project is scheduled with timelines and critical milestones. It is a very good method for developing systems to meet well defined, mathematical requirements. The customer tends to prefer this methodology as the progress of the development effort is well documented and scheduled in phases.

There are disadvantages of the model. It is difficult to use when a customer cannot clearly and specifically articulate system requirements. Documentation and analysis using Data Flow Diagrams (DFD), Entity-Relationship Diagrams and other Computer Aided System Engineering (CASE) tools can lead to a never ending cycle of analysis, or "analysis paralysis". There is very little room for risk analysis as the project progresses on its schedule.

Although not all aspects of the Waterfall Model were entirely appropriate for the ESU Intranet development, it did provide a structured methodology to follow. The chapters of this thesis, and the development aspects they cover, are related to each phase of development under the Waterfall Model. The seven development stages of the Waterfall Model, with the thesis chapters that correspond to a particular development stage, are presented in Figure 4.2.

<i>Waterfall Model Stages</i>	<i>Thesis Chapters</i>
1. Project Identification and Selection	Chapters II, III, IV
2. Project Planning	Chapters II, III, IV
3. Analysis	Chapter V
4. Logical Design	Chapter V
5. Physical Design	Chapters VI, VII, VIII
6. Implementation	Chapter IX
7. Maintenance	Chapter IX

Figure 4.2 Stages of Waterfall Model and Thesis Chapters

C. WATERFALL MODEL APPLIED

1. Project Identification and Selection

The first phase of the waterfall is project identification and selection. During this phase, a range of projects and ideas is considered and a general conceptual project idea is selected (p.24, Hoffer, George, Valacich, 1996). Selection is based on various factors such as feasibility, cost versus benefit, the readiness of the organization and the capabilities of the development team.

For this thesis, several potential USCG test environments were considered. These included an Intranet for a USCG cutter, for a small boat station, or for an office environment. Electronic Support Alameda was the final choice.

ESU Alameda was selected as the thesis sponsor primarily because it is an innovative Command which is on the cutting edge of the Coast Guard information technology changes. The ESU's Commanding Officer officially states in ESU Alameda Standard Operating Procedures Instruction 5400.1B that he expects each employee "to improve our system of doing business, to be innovative" (p.1, Lane, 1996).

ESU Alameda was especially receptive to the idea of sponsoring a prototype Intranet development effort. Unlike most Coast Guard units who have older, non-Windows based computers, ESU Alameda already had the hardware and software requirements necessary for a Microsoft Windows based Intranet. Specifically, they had networked IBM-compatible computers running Microsoft Windows NT Server and Workstation operating systems.

2. Project Initiation and Planning

During the project initiation and planning phase, the general information systems concept begins to take shape. The project is initiated when the customer is contacted. The feasibility of the project, the costs and benefits of it, the scope, and objective are all considered. For large scale systems development using the Waterfall Model, a formal report would generally be written after this stage which would cover all of these issues at length. (p.25, Hoffer, George, Valacich, 1996).

For this project, the process was much less formal. ESU Alameda was contacted and the Intranet idea proposed. The ESU Command welcomed the development effort and pledged its support. A cursory analysis of the current state of the ESU's information systems was done via telephone and the project was determined to be feasible. The ESU made money available for travel to Alameda in order to conduct the business analysis and agree on requirements.

3. Analysis

The Analysis phase is one of the most important steps to information systems design. It is when the client's business model is examined in detail. The design team must thoroughly understand current business processes and select candidate processes for Intranet development. The customer's requirements for a successful system are determined. The flow of information, data and business processes are exhaustively explored and diagrammed. (p.25, Hoffer, George, Valacich, 1996)

The business model analysis was conducted over a two day visit to the ESU. Interviews were conducted, meetings were facilitated, and documents researched in order to reach a clear understanding of the ESU's mission, their business model, and their way of doing business. Requirements analysis revealed the top goals and problems the ESU faced.

Following the business analysis, it was possible to narrow the scope of the project to focus on the Command's top priorities. These three top priorities were found to be:

- keeping better track of personnel movements and administration
- improving the supply ordering and procurement process
- status monitoring of Casualty Report (CASREP) service requests

The business analysis is thoroughly explored in Chapter V.

4. Logical Design

The logical design phase is when the components of the information system are defined without regard to any specific hardware or software platform. The functional goals of the system are visualized without consideration of the physical implementation.

The logical design phase focuses on business processes and conceptual system solutions for them. By the end of this phase developers should have a clear idea of what they want their system design to do. (p.25, Hoffer, George, Valacich, 1996)

A functional decomposition diagram (see Figure 5.9), which is the logical blueprint for the Intranet, was the main product for this phase of development. The diagram included all the system design goals without regard to actual physical design, software tools or hardware platform.

5. Physical Design

In this phase, the logical design is converted into an actual physical implementation. The process of turning the concept into a reality includes deciding what software tools to use, what platform to develop on, what language to code with. Chapter VI describes in detail why certain software tools were selected for developing the ESU Intranet. Chapter VII details the necessary steps to building the product.

It is impossible to express the tremendous amount of effort it took to learn, plan, write and document bug-free code to make the Intranet engine turn. Fortunately, it was possible to reduce the complexity by following the logical blueprint of a functionally decomposed system. Functionally decomposed means the Intranet was modular and broken down into parts. Individual parts and applications could be separately developed in discrete modules.

The interactions between modules of the system are complex enough, however, that good documentation of the code was absolutely critical to success. Considerable effort went into ensuring that descriptive documentation accompanied all code.

6. Implementation

Implementation includes all aspects of introducing the new information system into the organization. This includes installation, testing, and support (p.26, Hoffer, George, Valacich, 1996). The implementation phase is more than the technical aspects of physical installation and software loading. The social aspects of introducing an information systems change into an organization must also be considered. It is the social aspect, far more than the technical, which will ultimately determine the outcome of the implementation.

Managerial obstacles to a successful implementation of the Intranet are abundant. Any change that redefines the lines of communication in a system is likely to meet with resistance from employees who may prefer old, established patterns. These and other social change issues are explored in Chapter IX.

7. Maintenance

The final phase of the Waterfall Model is maintenance. Most of the lifecycle costs associated with a new information system occur during the maintenance phase. (p.26, Hoffer, George, Valacich, 1996) In many instances, the system designers are long gone when real problems occur. For this reason, it is incumbent upon the developer to provide the client with good documentation, training and a method for system change requests.

The ESU Intranet was designed with maintenance in mind. The code is painstakingly documented to allow for a higher degree of maintainability. A separate

"Help" Web site was included on the Intranet to provide information regarding maintenance, support, and systems feedback.

D. RAPID PROTOTYPE METHOD

Many customers don't know what to ask for or how to describe their information system needs. Showing them an example, or prototype, is a very effective method for allowing customers to clarify their requirements. The prototype can demonstrate capabilities of a technology that the customer did not even know existed. It provides a good starting point, which may then be adapted to the individual customer needs. The final result of this thesis, the ESU Intranet, is essentially a prototype.

Rapid Prototyping is a series of iterative loops of development, testing, feedback, and then development again (p.28, Hoffer, George, Valacich, 1996). Customer requirements are initially highly abstract, meaning they are fuzzy and unclear. The iterative loops of the Rapid Prototype method clarify the system requirements until, eventually, a working model takes shape. The prototype may then be used as a functional system or as a model for a larger development effort.

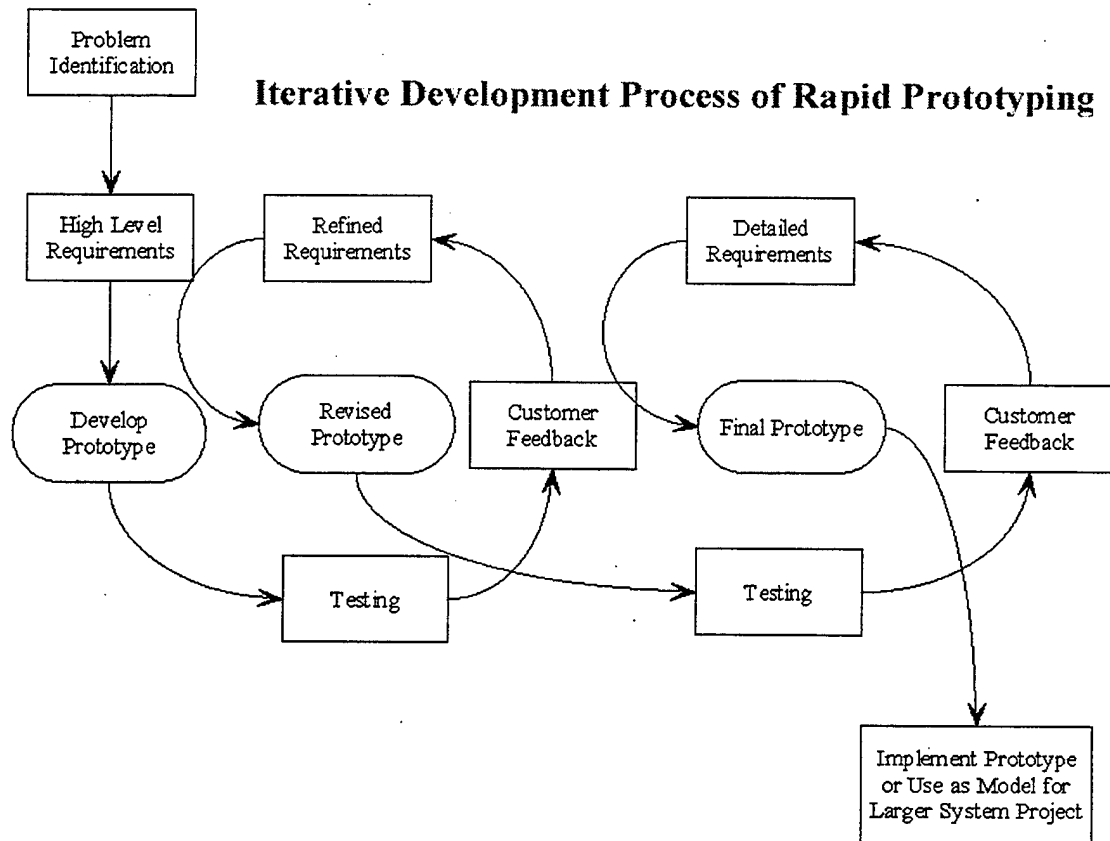

Figure 4.3 Iterative Development using the Rapid Prototyping Process

The Rapid Prototype method has advantages. It is ideal for a small, uncomplicated project. Development can begin before final approval of funds becomes available. Various modules and portions of the project can be developed without having to stick to a schedule or await critical milestones.

The method also has dangers. Unlike the Waterfall Model, which proceeds sequentially through seven well-defined steps including a physical design phase, the Rapid Prototype is always in the physical design phase. Since the requirements for the system are continually refined or changed throughout the development, the final product may turn into a “build and fix” solution. The resulting system code might not flow consistently and it is likely that it will be patchy and disorderly. This kind of tangled

“spaghetti code” can be difficult to maintain or understand. By contrast, a system developed using the Waterfall Model should have reasonably consistent code because all the requirements and specifications have been defined and logically modeled prior to physical design. The cost of a system developed by the informal Rapid Prototype model may be greater than the Waterfall Model in the long run.

E. CONCLUSION

This chapter defined two methodologies for systems development that were relevant to this thesis. The thesis progressed through each sequential phase of the Waterfall Model because it provided a baseline plan for the entire development effort. The result of the development under the Waterfall Model was a prototype ESU Intranet.

The Rapid Prototype model is relevant because the final result of the thesis, an ESU Intranet, can be regarded as simply one iteration of the model. The implementation process at ESU Alameda will determine if the final outcome falls to the left (first prototype), middle (revised prototype), or right (final prototype) in Figure 4.3. In any case, the ideal goal of the thesis was to provide the ESU with a “vision of what is possible” with Intranet technologies. If the prototype is adopted as a functional, operational system that is constantly revised and enhanced, as shown in Figure 4.3, then the goal will have been far surpassed. (See Chapter IX for more discussion on implementation issues.)

V. ANALYSIS

A. INTRODUCTION

The analysis phase focuses on the business model and processes of the client. A systems perspective was adopted to analyze the ESU business model. Instead of simply focusing on discrete linear processes, the potential benefits and consequences of Intranet technologies for the entire organizational system were considered. The idea that one should not simply automate existing paper processes was a guiding principle during the analysis phase. The goal was to obliterate, or re-define, old processes with the power of new Intranet technology.

This chapter will explore the business analysis and how it was conducted at ESU Alameda. The most important findings, specifically the identification of the ESU's top priorities, are presented. These top goals drove the Intranet development and narrowed the field of candidate processes to be modeled for Intranet applications. A logical, or conceptual, model was derived from the business analysis results. The logical model is presented here.

B. PROCESS ANALYSIS METHOD

1. Systems Perspective

The Fifth Discipline, by Peter Senge, advocates a systems approach to thinking about organizations, which provided the basis for exploration of the ESU business model. Systems thinking involves seeing the organization as whole system of circular interdependencies. The opposite of systems thinking would be to view the organization

as being broken up into unrelated, independent, linear processes. Systems thinking is about “seeing processes of change rather than snapshots” and “seeing interrelationships rather than linear cause-effect chains”. (p.73, Senge, 1990)

Simply automating existing paper trails with new Intranet technology would be like taking a “snapshot” of the process. Instead of approaching business processes one at a time, the research focused on business areas. The goal was to find ways of altering, enhancing or eliminating processes in ways that would benefit the entire organizational system, not just a single person. With its ability to improve communications across organizational boundaries, an Intranet is an ideal tool to approach from a systems thinking perspective.

2. Method

The field research consisted of two days of exhaustive interviews, meetings and documentation reviews. The original interview plan was to identify business processes, and match factors, such as how many people a process affects, against certain criteria. Correlation of these factors with these criteria was designed to indicate a process' suitability for an Intranet solution. The plan had to be modified mid-way through the site visit, as it became apparent that a much different method of analysis illustrated the business processes more clearly.

The research began with interviews of key personnel. Using a pre-planned set of questions and forms (see Figure 5.1), these interviews were intended to identify specifics of business processes and provide a foundation to rank order the suitability of a process for an Intranet solution.

ESU Alameda Process Analysis

Please pick one important process you do in your job (i.e. order parts) and answer these questions. Thank-you.

ESU Alameda Process Analysis Interview

What is your Rank, Rate and Job Title?			
Please pick one important process you do in your job (i.e. order parts) and answer these questions. Thank-you.			
What is this process?			
Please Describe it briefly.			
1. How many people does this process affect?	<input type="checkbox"/> One <input type="checkbox"/> Two <input type="checkbox"/> 3-5 <input type="checkbox"/> 6-10 <input type="checkbox"/> 10+ <input type="checkbox"/> 20 + <input type="checkbox"/> Everyone at Unit Other _____		
2. Who are the people or things that are affected by this process?			
3. How does this process affect them?			
4. Who are the people or things that use this process?			
5. How many people are involved in doing it?	<input type="checkbox"/> One <input type="checkbox"/> Two <input type="checkbox"/> 3-5 <input type="checkbox"/> 6-10 <input type="checkbox"/> 10+ <input type="checkbox"/> 20 + <input type="checkbox"/> Everyone at Unit Other _____		
6. Who is the primary owner (doer) of process?			
7. How often is this process used?	<input type="checkbox"/> Daily <input type="checkbox"/> Weekly <input type="checkbox"/> Monthly <input type="checkbox"/> Quarterly <input type="checkbox"/> Annually Other _____		
8. How often is this process updated?	<input type="checkbox"/> Daily <input type="checkbox"/> Weekly <input type="checkbox"/> Monthly <input type="checkbox"/> Quarterly <input type="checkbox"/> Annually Other _____		
9. Please identify some key personnel or things and how they interact with this process?	<table border="0" style="width: 100%;"> <tr> <td style="width: 50%; vertical-align: top;"> Person/Thing _____ <input type="checkbox"/> It is Updated Once, Used Once <input type="checkbox"/> It is Updated Once, Used Many Times <input type="checkbox"/> It is Updated Many Times, Used Once <input type="checkbox"/> Updated Many Times, Used Many Times </td> <td style="width: 50%; vertical-align: top;"> Person/Thing _____ <input type="checkbox"/> It is Updated Once, Used Once <input type="checkbox"/> It is Updated Once, Used Many Times <input type="checkbox"/> It is Updated Many Times, Used Once <input type="checkbox"/> Updated Many Times, Used Many Times </td> </tr> </table>	Person/Thing _____ <input type="checkbox"/> It is Updated Once, Used Once <input type="checkbox"/> It is Updated Once, Used Many Times <input type="checkbox"/> It is Updated Many Times, Used Once <input type="checkbox"/> Updated Many Times, Used Many Times	Person/Thing _____ <input type="checkbox"/> It is Updated Once, Used Once <input type="checkbox"/> It is Updated Once, Used Many Times <input type="checkbox"/> It is Updated Many Times, Used Once <input type="checkbox"/> Updated Many Times, Used Many Times
Person/Thing _____ <input type="checkbox"/> It is Updated Once, Used Once <input type="checkbox"/> It is Updated Once, Used Many Times <input type="checkbox"/> It is Updated Many Times, Used Once <input type="checkbox"/> Updated Many Times, Used Many Times	Person/Thing _____ <input type="checkbox"/> It is Updated Once, Used Once <input type="checkbox"/> It is Updated Once, Used Many Times <input type="checkbox"/> It is Updated Many Times, Used Once <input type="checkbox"/> Updated Many Times, Used Many Times		
10. What is the type of information or data input for this process?	<table border="0" style="width: 100%;"> <tr> <td style="width: 50%; vertical-align: top;"> <input type="checkbox"/> General (i.e.. ALCOAST messages) <input type="checkbox"/> Private or <input type="checkbox"/> Classified or <input type="checkbox"/> Low Volume or <input type="checkbox"/> Medium Volume or </td> <td style="width: 50%; vertical-align: top;"> <input type="checkbox"/> Customized (i.e. writing the Plan of Day) <input type="checkbox"/> Non-private <input type="checkbox"/> Unclassified <input type="checkbox"/> High Volume </td> </tr> </table>	<input type="checkbox"/> General (i.e.. ALCOAST messages) <input type="checkbox"/> Private or <input type="checkbox"/> Classified or <input type="checkbox"/> Low Volume or <input type="checkbox"/> Medium Volume or	<input type="checkbox"/> Customized (i.e. writing the Plan of Day) <input type="checkbox"/> Non-private <input type="checkbox"/> Unclassified <input type="checkbox"/> High Volume
<input type="checkbox"/> General (i.e.. ALCOAST messages) <input type="checkbox"/> Private or <input type="checkbox"/> Classified or <input type="checkbox"/> Low Volume or <input type="checkbox"/> Medium Volume or	<input type="checkbox"/> Customized (i.e. writing the Plan of Day) <input type="checkbox"/> Non-private <input type="checkbox"/> Unclassified <input type="checkbox"/> High Volume		
11. What is the current status of data storage and computer or network automation of this process?	<input type="checkbox"/> Manual (i.e. using desk folders, filing cabinets, etc.) <input type="checkbox"/> Partly Automated (non-networked standalone computer) <ul style="list-style-type: none"> • Using Word Processing files • Using Database <input type="checkbox"/> Fully Automated (using non-networked standalone computer) <input type="checkbox"/> Fully Automated and Networked with links to other processes <ul style="list-style-type: none"> • Computers exchange information, files, data with other people or processes <input type="checkbox"/> Already on the Intranet		
12. Comments or any other			

Figure 5.1 Original Process Interview Questionnaire

Using the prepared interview questionnaires was not as successful as anticipated. Personnel were unable to clearly articulate, in words, the specific information flows and processes of their day to day work. One on one interviews failed to produce useful

information until the approach was modified to drawing pictures that modeled an employee's daily processes.

The most valuable method of understanding the ESU Alameda organization and business process flows was to talk through the jobs of key personnel by drawing them on whiteboards as Data Flow Diagrams (DFD). The DFDs helped ESU employees articulate what information flowed to whom, why, where it was stored and how it was used. The parts and supply ordering process, for example, was so complicated that it was almost impossible to describe without using a drawing. The process is shown in Figure 5.2 as a DFD.

solution to the supply process were developed which significantly reduce the complexity found in Figure 5.2. (See Figures 5.5 through 5.7 for the new DFDs.)

C. ESU ALAMEDA BUSINESS MODEL

1. Overview

ESU Alameda is responsible for the maintenance and support of all electronics throughout their Coast Guard geographic area of responsibility. They are a mid-sized service oriented organization with roughly 50 employees. They are a fairly typical USCG unit with most of the same pressures, procedures, and paperwork of any other unit.

2. ESU Customers

The ESU has internal and external customers who could benefit from Intranet solutions to day-to-day business needs.

Internal customers can be grouped in many ways, from command or management level to the office worker. Internal customers could be grouped by rank, civilian or military. Internal customers have different needs depending on which group they belong to.

Its' external customers, those whom the ESU provides services for, would be interested in ESU products and news relevant to their service requests. Other external customers could be anyone who needs to reach the internal employees of the ESU.

3. Organization

ESU Alameda is a typical hierarchical organization organized in a tree structure. It has a military chain of command beginning with the Commanding Officer (CO) and Executive Officer (XO) at the top. The ESU is then divided into distinct divisions, or branches, with a Division Head in charge of each.

ESU Alameda Organization (Active Duty)

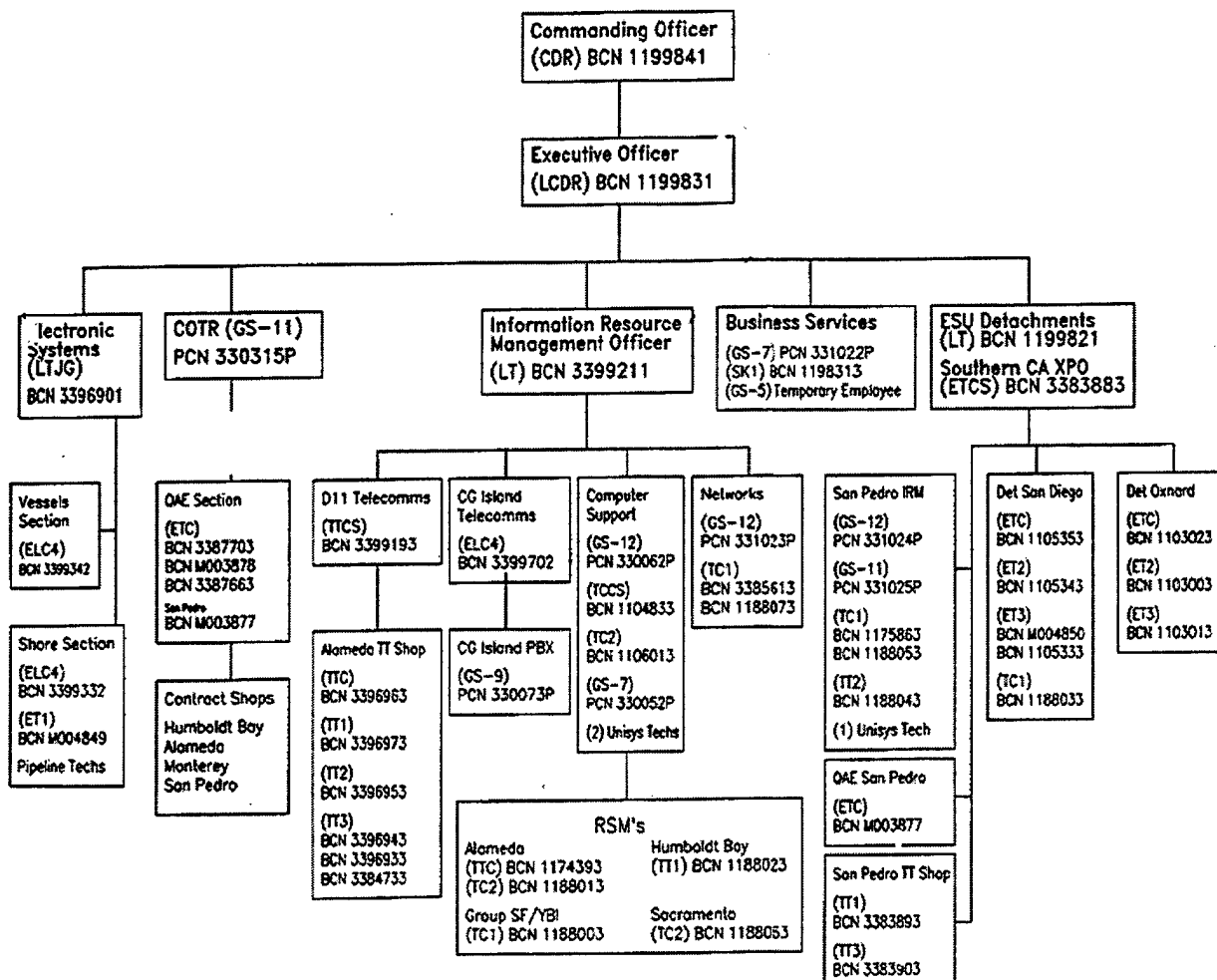

Figure 5.3 ESU Alameda Organization

4. Information Flows

Approval authority for ESU policy decisions, personnel actions or budget allocation follows the traditional military chain of command. Final responsibility for all decisions at the Command rests with the CO.

The CO delegates his authority as appropriate. ESU Alameda considers itself an innovative organization. Despite the traditional hierarchical structure, information flows are not strictly linear. The CO states clearly in the ESU Standard Operating Procedures that he expects employee empowerment and communication across organizational boundaries.

“My intent is ... to encourage action and decision making at all levels... Use the organizational chart as a starting point; it's not set in stone... (p.2, Lane, 1996)”

5. Business Model Analysis

The business model analysis was approached from a high level of abstraction where, first, the fundamental mission of the organization was identified. Following that, the long-term goals that support the mission were ascertained. Next, the critical success factors necessary to accomplish the long-term goals were found. Finally, the specific processes that contributed to each critical success factor were determined. Figure 5.4 provides a snapshot of this analysis.

Missions <i>USCG ESU Alameda is responsible for..</i>	Goals <i>To accomplish the mission, USCG Alameda's goal is to...</i>	Critical Success Factors <i>To be successful and accomplish the goal, USCG Alameda must have...</i>	Processes <i>To be successful, these processes occur..</i>
Providing world class, top quality electronic support to customer units	Ensure operational readiness of all mission essential equipment onboard USCG units in the area of responsibility	<ul style="list-style-type: none"> • Means to determine inventory, parts, and supply order status. • Means to anticipate personnel administrative needs and whereabouts far enough in advance to budget these costs • Means to determine status and location of outstanding Casualty Reports (CASREPS) • Means to track results of repairs and customer satisfaction • Means of communicating with internal and external customers 	<ul style="list-style-type: none"> ⇒ Track supply order chain. ⇒ Track and forecast current personnel whereabouts and admin ⇒ Information flow to ESU to maintain database with current outstanding CASREPS and work orders ⇒ Measure customer satisfaction and store data ⇒ Measure trouble calls and store data

Figure 5.4 ESU Alameda Business Model Chart

This systems thinking approach to analysis was intended to eliminate noise by identifying the truly important processes, which could be, traced back to supporting the ESU's mission. Business practices that were not aligned with the ESU's strategic goals, or did not add value to the ESU's critical processes, were not considered candidates for Intranet solutions.

D. CRITERIA FOR SELECTION OF INTRANET SOLUTIONS

1. Command's Top Goals

So many processes were suitable for Intranet solutions that the scope had to be narrowed in order to have any reasonable chance of accomplishment. The Command's top goals, or problems to manage, were clearly uncovered during the research. The top three were found to be:

- keeping track of personnel movements and administration
- improving the supply ordering and procurement process
- status monitoring of Casualty Report (CASREP) service requests

The development effort concentrated on broadly meeting the top goals of the ESU Command rather than focusing on a specific workgroup's narrowly defined problems. The high level focus makes the most sense from a systems perspective because the Command's priority processes are global, meaning their impact stretches throughout the entire organization.

2. Feasibility

The scope of the Intranet project was limited on a practical basis due to constraints such as limited time, technical feasibility, and developer skill. The difficulties of turning a logical, or conceptual, design into a reality were significant. These constraints are addressed in Chapter III.

3. Showcase Intranet Potential

Bearing in mind that one goal of this thesis is to demonstrate the power of an Intranet for a Coast Guard unit, it follows that one of the criteria for selection of Intranet processes was to showcase the potential and capabilities of the technology. Applications that could change the organization, obliterate inefficient processes, or distribute information horizontally across departments, were conceived. The CO's principle, as stated in the SOP, to "allow maximum flexibility ... for action and decision making at all levels" was guiding. (p.1, Lane, 1996)

E. LOGICAL DESIGN

1. Requirements Analysis

Informal requirements analysis was used because the goal of the project was to demonstrate the capabilities of a new technology and the requirements were unclear. The business model was examined, as described above, and an informal conceptual idea of the desired functionality was attained. Informal requirements analysis was a continual process of refinement because, basically, people did not know what an Intranet is so they could not articulate firm requirements for one. This is why one simple goal of the project is to build a prototype and demonstrate what is possible.

2. Data Flow Diagrams

Data Flow Diagrams, resulting from research into the ESU business model revealed the critical elements of ESU business practices. It was then possible to imagine new methods of doing business, and new DFDs, that take advantage of Intranet technologies. These new logical designs change many elements of the process including the forms used, the persons involved, and the roles played by each.

The chaotic complexity of the parts ordering system, as seen earlier in Figure 5.2, is significantly changed when remodeled with Intranet technologies. The new DFD redefines the roles of the storekeeper and the person who places an order. In the new DFD, the person placing the order has more information immediately available to them, but they also must take more responsibility for personally tracking the order's status. This alleviates time the storekeeper previously spent tracking orders.

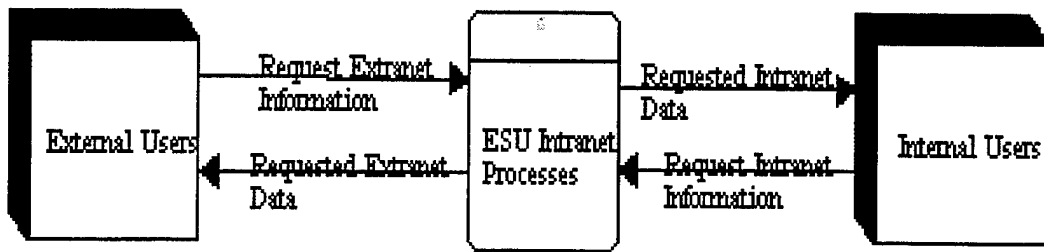

Figure 5.5 Level 0 DFD for Entering Intranet

In the Context Level DFD shown in Figure 5.7, either an internal or external user enters the ESU Intranet.

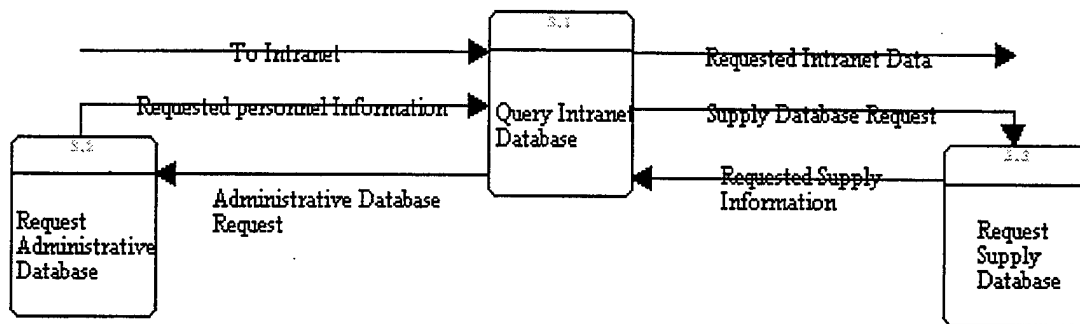

Figure 5.6 Level 1 DFD for Intranet

In the Level 1 DFD, the Intranet user can select to enter the Supply application.

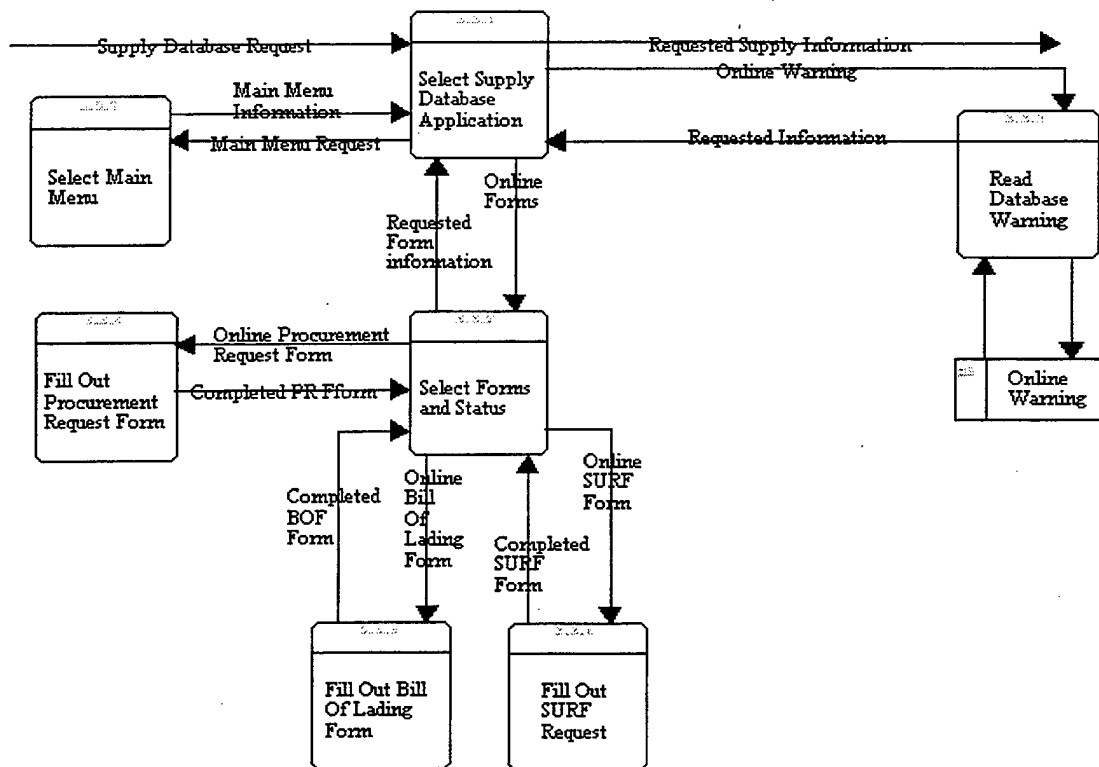

Figure 5.7 Level 2 DFD of Supply Application

The Level 2 DFD shows the logical information flow for a Supply database application. This new model greatly reduces the complexity of the original supply and parts ordering processes shown earlier in Figure 5.2.

New DFDs that incorporate Intranet solutions were developed for other processes uncovered during analysis. They included DFDs for personnel administration, leave tracking and distributing communications.

The decomposition of the processes beginning from a high level of abstraction and working down into the details of the process clearly illustrates the systems focus of the Intranet logical design. DFDs were crucial to understanding the information flows of the system. They provided excellent conceptual blueprints of the system processes and interrelationships, as well as good starting points for actual physical design.

3. Desired Functionality

The desired functionality of a prototype Intranet was determined by the criteria indicated above; the command's top goals, feasibility, and a showcase for the potential of Intranet technology. Using those guidelines, the developer settled on several functional application concepts for the Intranet. They are listed here in a table with the desired logical application and the selection criteria.

Application	Does it Address Command's Top Goals?	Is it Technically Feasible?	Does it Showcase Intranet Technology?
Leave Request	yes	yes	yes
Phonebook	yes	yes	yes
Customer Service Hotline	yes	yes	yes
Supply Tracking	yes	somewhat	yes
Temporary Assigned Duty	yes	yes	yes
Personnel Reports	yes	yes	yes
File Uploads/Downloads	yes	yes	yes
On-line Discussion Forum	yes	yes	yes
CASREP Tracking	yes	yes	yes

Figure 5. 8 Logical Applications with Criteria for Selection

4. Functional Partitioning

Functional partitioning is a process of describing what a system is intended to accomplish, and then breaking the system into the components that will do it. The desired functionality of the Intranet is shown in Figure 5.9 as a functionally decomposed logical design. This method of logically viewing a system is neat and modular which provides a good starting point for the actual physical design. All of the components that were anticipated for development, starting with the top "system level", and layering down, are shown.

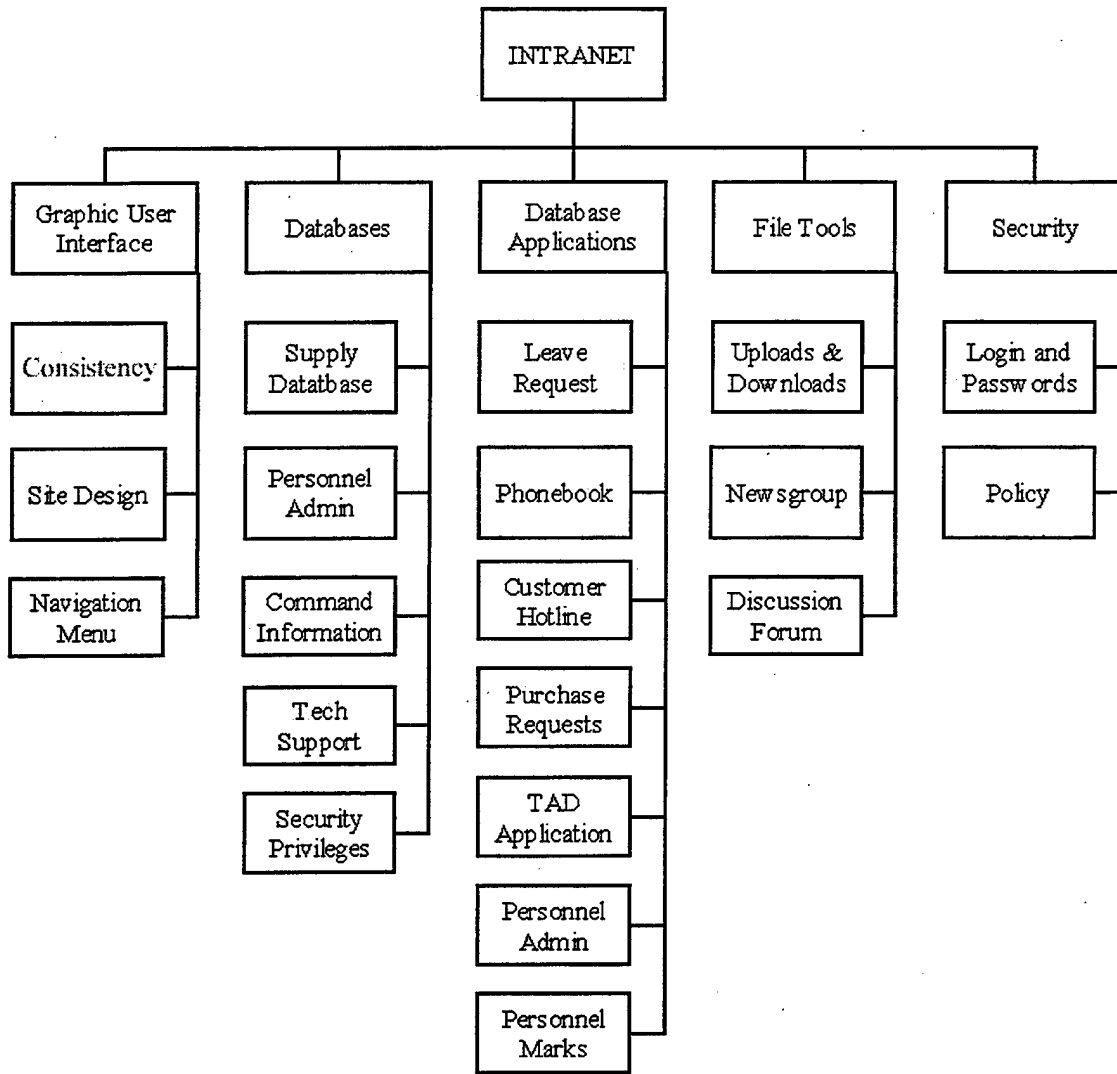

Figure 5.9 Functional Decomposition Diagram of ESU Intranet

This functional decomposition diagram was a major product of the logical design phase of ESU Intranet development. The diagram includes all the system design goals without regard to actual physical design, software or hardware platform.

F. CONCLUSION

This chapter described the process of research and analysis of the ESU Alameda business model. The criteria for selection of Intranet processes were introduced and the

logical design of an Intranet system was presented. The end of the Analysis Phase marked the demarcation point between concept and reality. The first five phases of the Waterfall Model resulted in a logical picture of the desired system. What remained ahead was the hard work of building the system to the blueprint.

VI. SOFTWARE TOOLS

A. INTRODUCTION

Specific software tools are required to create an Intranet. All Intranet users require a Web browser to view Web pages on the site. The developer must have a tool to design individual Web pages as well as to visually develop an organized Intranet site layout and navigation scheme. A database program is necessary to store, query and add Intranet data to. The middleware component facilitates interaction between a Web browser and a database. Finally, an Internet Web Server is required to host the Intranet site.

B. SOFTWARE TOOLS

1. General Selection

The criteria for selecting software tools included assessing cost, availability, ease of use, functionality and compatibility with current Coast Guard platforms. A complete Microsoft solution was chosen primarily because their software tools met all of those criteria. Microsoft's tools were easy to learn, they were available at no cost, and each product seamlessly integrated with another. As well, Microsoft Windows NT and Microsoft Office Suite are the official standard Coast Guard operating system and office tools, respectively.

The software tools necessary and the ones chosen are listed below:

Software Tool:	Version Used:
1. Web Browser	Microsoft Internet Explorer 4.0
2. Web Page & Site Authoring	Microsoft Front Page 98
3. Database	Microsoft Access 97 (ODBC Compliant)
4. Database Middleware Component	Microsoft Active Server Pages 1.0
5. Web Server	Microsoft Internet Information Server 3.0
6. Operating System	Microsoft Windows NT 4.0
7. Miscellaneous Components	Microsoft ODBC ASPMail 2.5

Figure 6.1 Software Tools Chosen for Intranet Development

2. Web Browser

An Intranet is viewed through any standard Web browser. Web browsers translate the coded text files, mostly written in Hypertext Markup Language (HTML), into graphic pages displayed in the browser's window. One of the most powerful features of a Web browser is that it provides a standard application interface for any Internet or Intranet content, regardless of the hardware platform the Web browser is running on.

Internet Explorer 4.0 (IE4) was chosen for its easy integration with other Microsoft Office applications, its stability, its support for Web scripting languages, and its optimal suitability for interfacing the Microsoft Active Server Pages middleware component.

The other alternative was to adopt Netscape Communicator. There are, in fact, only very minor differences, such as slight color variations and small differences in where graphics are displayed, in the way Web pages appear in the different browser windows.

One of the most significant features of the Intranet is that it is platform and Web browser independent. It can be viewed on any standard Web browser. The Intranet is only optimized for IE4 in the sense that the day to day testing and development effort was done using IE4.

3. Web Page Authoring and Web Site Management

Web pages are the essential components of the Intranet site. The Web page authoring tool is the most frequently used software tool for the site's development and management.

Requirements for selection of this tool included ease of use, reliability, standardization and site management capabilities. Front Page 98 (FP98) was chosen as the Web site and Web page authoring tool because of its strong support for total site management. It seamlessly integrates with the other Microsoft products such as Windows NT, Windows 95, Internet Explorer 4.0, and Active Server Pages. The visual development environment of FP98 was easy to use and learn. The development interface also allows for immediate access to the raw, underlying HTML code. Access to HTML code is necessary because some elements of Web page design cannot be accomplished through a visual interface alone.

An alternative to FP98 is Net Object's Fusion site tool. Fusion has a very intuitive visual interface for Web page and site design. Fusion was not chosen because, before publishing to the Web server, it pre-stages the visual layout of a Web page and site in a proprietary file format called NOF. It isn't possible to edit underlying HTML code

when the files are stored as NOF files. Since it is sometimes important to access HTML code while programming, Net Objects Fusion was not a good solution.

4. Databases

Database development was with Microsoft Access 97. Familiarity with the product, the fact that it is in everyday use at the sponsoring command, and the fact that it is a Microsoft product were the leading criteria for its selection as the Intranet database tool. Access 97 is designed for a small office environment but can easily scaled up to a more powerful tool like Microsoft SQL Server.

Access 97 is Open Database Connectivity (ODBC) compliant. ODBC is a standardized interface, which allows applications to have access to the data inside a variety of different databases, regardless of their unique formats. ODBC provides a middle layer that hides the differences between database formats (Fleet, Warren, Chen, Stojanovic, 78).

Any ODBC compliant database, such as those offered by IBM, Oracle or Informix, could be used on the Intranet. These options are designed for enterprise wide applications and were considered beyond the scale of this small project.

5. Middleware

Middleware provides the language for communication between a database on a server and the pages generated dynamically and output to a client's Web browser. Deciding on a powerful, yet easy to use, middleware solution is a crucial decision for the Intranet developer. This project uses Microsoft's Active Server Pages.

The field of alternatives is wide. There were many alternatives for large database, enterprise wide solutions from Oracle and Informix. These solutions were more appropriate for large mainframe based operations. For the mid-sized organization, middleware products such as IBM's Domino and Microsoft's SQL server compete. The alternatives for a small office setting included Allaire's Cold Fusion and Microsoft's Active Server Pages (ASP). Both Cold Fusion and ASP can be scaled to larger settings, all the way up to enterprise. The enterprise products, however, were considered too powerful for this thesis.

Cold Fusion is arguably the most established middleware product available today. Allaire's most recent version even includes a visual development tool for Web enabling databases. Cold Fusion has been on the market for several years and is currently in use by such companies as Federal Express, Dell Computer and Ticketmaster (Forta, 1997).

Microsoft's Active Server Pages middleware product is relatively new. The term Active Server Pages is less than two years old. Microsoft currently has no visual tool available for writing ASP code and everything must be handwritten using a text editor.

Both ASP and Cold Fusion are middleware products that run on a host server and are very similar in their implementation and execution. The code is executed on the Web server, which will then query a database, and finally dynamically generate a Web page based on that query.

The primary criteria which led to the selection of one product, Microsoft's Active Server Pages, over another, Allaire's Cold Fusion, was cost. Microsoft's product is free and will run on any Windows NT server where ASP is installed. Cold Fusion costs close to one thousand dollars per license.

Other criteria included Microsoft's implementation of Visual Basic Script (VBScript) as the language to manage the interactions between the Web server and client. VBScript is an extension of the Visual Basic language, which is widely supported. New components that work with ASP are constantly being developed and sold by third-party vendors other than Microsoft. Cold Fusion, in contrast, uses a proprietary scripting language and specialized "tags" throughout for its code.

6. Internet Web Server

The Internet Web Server hosts the site. Microsoft's Internet Information Server 3.0 (IIS) was the natural choice because it is free as an integral part of the Windows NT 4.0 operating system. Windows NT 4.0 is the Coast Guard's official standard operating system. ASP was also designed to run on IIS.

C. CONCLUSION

The software choices made here determined the shape of the resulting Intranet product. These tools have both their strengths and limitations when compared with other tools. Nevertheless, they all met the most important criteria for selection, which was cost, ease of use, functionality, and quality.

VII. PHYSICAL DESIGN

A. INTRODUCTION

Physical design is the fifth phase of the Waterfall Model. The physical design phase took four months of development effort during which, the prototype Intranet was physically built. Intranet applications took shape through an iterative, Rapid Prototype process of design and redesign.

This chapter briefly describes the technical aspects of physically building an Intranet. A tutorial on how to connect to a database through a Web browser, using Active Server Pages, is presented here. Finally, graphic user interface design principles and security aspects of the Intranet are discussed in this chapter.

B. PHYSICAL DESIGN STEPS

Turning an Intranet concept into a reality requires following certain general steps. This following section describes, as a short tutorial, the basic design steps for a Windows NT based Intranet using Active Server Pages.

1. Web Server

A Web server must be installed on the machine that will host the Intranet site.

2. Web Authoring Tools

Web authoring tools used to build the site must be installed on the Intranet design machine. The machine must be on the network in order to publish to the Web server.

3. Middleware

The middleware component that will allow an ODBC compliant database to communicate with a Web server must be installed.

4. Database

A database to hold Intranet data must be developed. Care should be taken to note the design details, such as table and field names, as familiarity with the data structures is crucial to allow the Intranet to interact with them.

5. Data Source Name (DSN)

Using the ODBC control panel from the Windows Operating System, Data Source Names (DSN) for the databases must be created. These names will be used in the middleware code to reference the Intranet databases.

6. Intranet

The physical design should follow the logical blueprint. Authoring Web pages and building a site layout creates the Intranet. Some of the Web pages may use scripting code and to communicate with a database (through middleware) for information retrieval, queries and updates.

C. CONNECTING TO A DATABASE WITH ASP

1. Introduction

This section is a brief introduction of how to connect to a database through the Web browser using Active Server Pages. The example only provides a very basic overview of the most general method used to do this on the ESU Alameda Intranet.

The examples found here show the ASP code as it is written into the Web page. The code for ASP pages are found only on the server because the server uses the underlying ASP code to dynamically generate HTML code when a page is requested. The client browser that initiates a request to the Web server never sees the ASP code.

2. Database

An Access database used on the ESU Intranet is called "phonebook.mdb". The database has several tables. This tutorial will focus on one table called PERSON, which contains fields for employee data.

PERSON : Table			
	Field Name	Data Type	Description
	Rank	Text	Enter the rank of the CG person
	Rate	Text	Enter the rate of the CG person
	FirstName	Text	Enter the first Name of the person
	MiddleInit	Text	Enter the middle initial of the person
	LastName	Text	Enter the Last name of the person
	Street	Text	Enter the street address of the person
	City	Text	Enter the city the person lives in
	State	Text	Enter the state the person lives in
	Zip	Text	Enter the zip code at the person's living quarters

Figure 7.1 Person Table of Phonebook Database

3. ODBC and the Data Source Name

This database has been configured as an ODBC compliant DSN with the name “phonebook”. The DSN name is important to remember because it is used to reference the database in the ASP code.

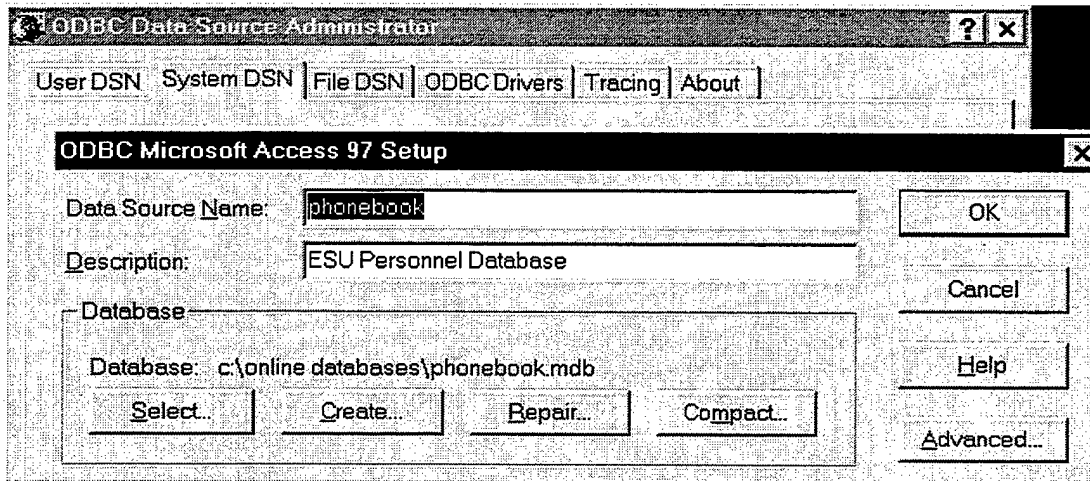

Figure 7.2 ODBC System DSN Setup Window

4. Connection Object

ASP code is written in Visual Basic script. In this example, a connection object is instantiated and named **Conn**. The connection is made to the ODBC DSN “phonebook”. Objects can have properties about them and methods that act on them. In this case, the open method is used on the connection object.

```
<% // Set up connection and open it  
  
Set Conn = Server.CreateObject("ADODB.Connection")  
  
Conn.Open "Phonebook" %>
```

5. Recordset Object

The recordset object is used primarily to store the results of a database query. It may be thought of as a virtual table in memory, made up of rows and columns. In this example a recordset object is instantiated and given the name **rs**.

```
<% ' // Set up recordset  
  
Set RS = Server.CreateObject("ADODB.RecordSet") %>
```

6. Define SQL

The Structured Query Language, SQL, for the desired database query is assigned to a variable named **SQL** in this example.

```
<% ' // Define SQL  
  
SQL = "SELECT FirstName, LastName FROM Person" %>
```

7. Execute the Query

Using the recordset open method, the SQL query can be executed.

```
<% ' // Run Query  
  
RS.Open SQL, Conn %>
```

8. Display the Results

Finally, the results of the SQL query, which are stored in the recordset object "rs", can be displayed. The response.write command (composed of a response object and its write method) is used to display the contents of the recordset. A Visual Basic loop, the MoveNext method, and the End of File property are used to loop through the recordset until all records are displayed.

```
<% ' // Write each row  
  
DO WHILE NOT RS.EOF  
  
    response.write RS("LastName") & ", "  
  
    response.write RS("FirstName") & "<BR> "  
  
RS.MoveNext  
  
LOOP  
  
RS.close%>
```

D. GRAPHIC USER INTERFACE DESIGN PRINCIPLES

1. Introduction

Simplicity, consistency, elegance, content and usability were the underlying Graphic User Interface (GUI) design principles. The following brief list highlights some of these principles:

- **Minimal use of distracting colors, flashy logos, or pictures.**
- **Focus on consistency across all pages.** A common background and header is used on all Web pages.
- **Cautious use of frames.** Frames are used to divide the Web browser window. Frames are tricky to program and can be distracting and annoying if they are used improperly. The ESU Intranet only makes use of frames once, for the left side navigation bar.
- **Content is king.** Every page on the site must have some function, purpose, or utility to be included on the site.

The design principles are discussed in greater detail in the paragraphs below. Screen shots of the Intranet's pages are presented in Chapter VIII.

2. Consistency

Consistency was key in designing the site. Every page has a consistent visual background, color scheme and titles. Tasks performed within specific applications are performed in a similar manner across all application areas. For example, submitting an on-line Leave Request in the Leave Application is almost identical to submitting an on-line Temporarily Assigned Duty (TAD) Notification in the TAD Application.

3. Current Content

Currency and relevancy was another important GUI design principal. The most dynamic data, which changes with the greatest frequency, is immediately presented up front on all page layouts. For example, the Intranet Home Page presents the visitor with the most current data from four application areas. At a glance, the visitor can see who is currently on leave, who is currently away on TAD, what general announcements have been broadcast for the command and what user access level they are logged in at. The user may follow hyperlinks to drill down into more details of this data. They may also scroll down the Home Page for other information that changes less frequently. All pages across the Intranet are designed with the principle of putting the most current and relevant data at the top of the page. A link is included to further drill down into details about the data.

4. Usability

Usability was another GUI design principle. The applications were designed to be used intuitively with little or no user training and with minimal danger of user errors. All interactions with the back-end databases are through a common Web browser interface. Anyone who is familiar with using a standard Web browser to navigate the Internet should have no difficulty understanding how to use these Intranet applications. A user only needs to know how to follow hyperlinks and to submit on-line forms.

The only foreseeable areas where users can make mistakes is in either the submission of on-line forms or in the unintended modification or deletion of on-line records. In submitting on-line forms users may enter invalid datatypes in certain fields which could cause the back end database to reject the entire form. Care has been taken in the design process to validate data before it is submitted to the database to minimize this risk. There are cases however where data validation is not easily implemented, such as validating date formats. In these instances, the possibility exists that the user may enter invalid data or an unrecognized format, which will cause an error. In all cases, the user has to redo their form or delete the erroneous data.

5. Deletions

All deletions across the Intranet are handled in the same manner. Deleting records is not a simple one-click process. The user is clearly informed of what they are about to delete and given the opportunity to back out. When a delete request is made, a warning alert box pops up in the browser window which informs the user that deleting records is a serious matter and should only be performed by personnel authorized to do so. The user

must click "OK" to continue. Next the user is presented with all the information that will be deleted. There is a warning banner in red across the top of the page. A cancel button is prominently displayed in case the user made a mistake. Finally, to perform the delete the user must press a very large red button that clearly indicates they are about to delete a record.

Deleting records requires deliberate, informed action on the part of the user. The site was designed so that there is very little possibility that the user will mistakenly delete data. The possibility exists, however that an unauthorized person will delete records that do not belong to them. Backups are recommended in case this happens. Command policy on acceptable use should specifically address this issue of unauthorized deletion and modification of data.

6. Site Navigation and Menu Bars

A left-hand vertical navigation bar is implemented as a frame and is always present in the Web browser window. The menu bar contains links to general application areas. The bottom of each page contains a horizontal menu bar with links to the specifics in each of the application areas. The menu also has a link to a site map, which displays all links available to Intranet users.

The left-hand navigation menu is implemented in JavaScript. This enhances the GUI human computer interaction because the links change color when the mouse pointer is passed over them.

E. SECURITY FEATURES

1. How to Use the Security Features

The command will need to decide on at least four username and password combinations to cover the four security access privilege levels. These levels are “sec admin”, “admin”, “user” and “guest”.

A visitor to the Intranet may choose to log in at one of the security levels (assuming they have the appropriate username and password) or they may browse the “Public Access” areas of the site that are available to the “guest” access privilege level.

Once a user has successfully logged in, a variable containing the security access privilege level value is set and maintained for the duration of their visit. The variable is temporarily stored as a cookie in the Web browser using the Active Server Pages session object. The session object stores the security access level for the duration of a visit. It expires when the visitor exits the Web browser or after twenty minutes of inactivity.

- **Guest** access is the default access level for anyone who has not logged in and is browsing the “Extranet -public access” areas of the Intranet. This level is intended for outside visitors and anyone who is not a part of the ESU unit..
- **User** access is the default access level for anyone who is a member of the ESU unit. This level allows access to most areas under the “Intranet - members only” banner of the menu bar. It requires logging in with a valid username and password. All members of the unit should be given the username and password for this access level. Logged in users can view most information that is specific to the ESU such as personnel information and recall logs. Users

may also add, edit and delete most records contained in the back-end databases. Submitting on-line forms such as leave requests, temporary duty notifications, and the posting of general announcements can be done once logged in under the user access level.

- **Admin** access is designed as the default access for supervisory level positions at the ESU. This level is used to restrict access to pages that require on-line approvals of forms submitted on-line. Admin access allows everything that can be done under **user** as well as access to all remaining areas of the site. It is recommended that a limited number of personnel hold this access level as one can do almost everything on the site already under the user level. Admin access should only be granted those persons who hold supervisory positions such as department heads, the executive officer and the commanding officer.
- **Sec Admin** access is the highest privilege level. This level is designed as the top level primarily for administering the databases and deleting sensitive records. Only one or two people should have sec admin access. Presently, only one application, deleting a personnel record, requires this access level. Because deleting a personnel record causes a cascade delete, where the primary record and all related records are deleted, one should be cautious in who has access to the delete feature.

2. Security Policy Considerations

The command is encouraged to test the security implementation as presented and modify it as necessary. As a matter of policy, the command may want to further restrict,

or allow greater access to certain information contained on the site. The command may want to implement individual usernames rather than the four generic usernames.

- **Usernames:**

The default Intranet username which allows **user** access should be distributed freely to all members of the ESU. A specific warning should prohibit ESU members from disclosing the username and password to **anyone** who is not a part of the unit. It is recommended that all users sign a form to attest to their compliance.

- **On-line "Digital Signatures":**

Many on-line forms are simply automated versions of an equivalent paper form. These forms have the same approval chain as the paper forms which were previously routed through the various inboxes and outboxes of the ESU. Instead of a pen and paper signature, these forms rely on a "digital signature". The digital signature generally consists of no more than a check in a box and the pressing of a submit button in the Web browser.

Access to these pages where approvals occurs is limited to users logged in with security access level of **admin**. It is recommended that ESU command policy for acceptable use of the Intranet specifically address the following: that only authorized personnel may digitally sign (hit the submit button) on-line forms and requests. It should be pointed out that an unauthorized digital signature on-line is the same as forging a signature on the equivalent paper form. Presently, even if the digital signature policy was abused, it would not

cause mission critical harm (i.e. no money would be misappropriated or personnel records lost). At the worst, a member might forge his or her own signature for a leave request. Nevertheless, the viability of this security model for “digital signatures” should be tested and policy adjusted accordingly.

3. How Security Works

Username and passwords are stored in the “phonebook” database under a table named “users”. Security is implemented on a page by page basis. Every request for a page that is protected will first be redirected to a security access level check. One simple line in the HTML code, called a “server side include”, will redirect the request to a file which is executed before the HTML page is loaded. The include file contains code which checks the a session object variable. This variable stores the security access privilege level variable assigned to users based on their login. Presently there are three server side include files implemented for user, admin, or sec admin access respectively.

1. `<!--#include file="../user_access.inc"-->`
2. `<!--#include file="../admin_access.inc"-->`
3. `<!--#include file="../secadmin_access.inc"-->`

Only one of each type needs to be included before the HTML header for pages that are to be protected.

The following code is an example of using the server side include file to restrict access to a page. First the page is commented with an Active Server Pages header, next the server side include file is in bold, and finally the beginning of a typical HTML page is

shown. If the user successfully negotiates the "admin_access.inc" file then the rest of the HTML page is loaded. Otherwise the user is redirected to a "No Access Allowed" page.

```
<%  
  
' * For every page that you want to enable access control, put the include  
' * file and this file in the same directory.  
  
' * Type <!--#include file="../LoginCheck.inc" -->  
  
' * BEFORE the <html> tag (very important) at the top of the page you  
' * want to control access to. %>  
  
<!--#include file="../admin_access.inc"-->  
  
<html>  
  
<head>  
  
<title>Pending Leave Requests</title>
```

The source code for the page by page security solution was taken from Jon Mnemonic's article "Access Control With a Database" published on-line at "The ASP Hole".

F. CONCLUSION

This chapter discussed the technical details of the physical design phase. The actual development effort took months of ASP and HTML code programming.

VIII. APPLICATIONS

A. INTRODUCTION

This chapter shows the results of the physical design phase, which are the Intranet and its applications. The Intranet is composed of over 80 custom built Web pages. Screen shots of important pages, with brief descriptions of how the applications should be used, are presented here. The goal is to present the reader with an idea of the basic feel and functionality of the Intranet application areas.

B. APPLICATION NAVIGATION STRUCTURE

The navigation menu of the Intranet is arranged functionally by application area. Figure 8.1 shows each the significant pages of Intranet and how they are navigated.

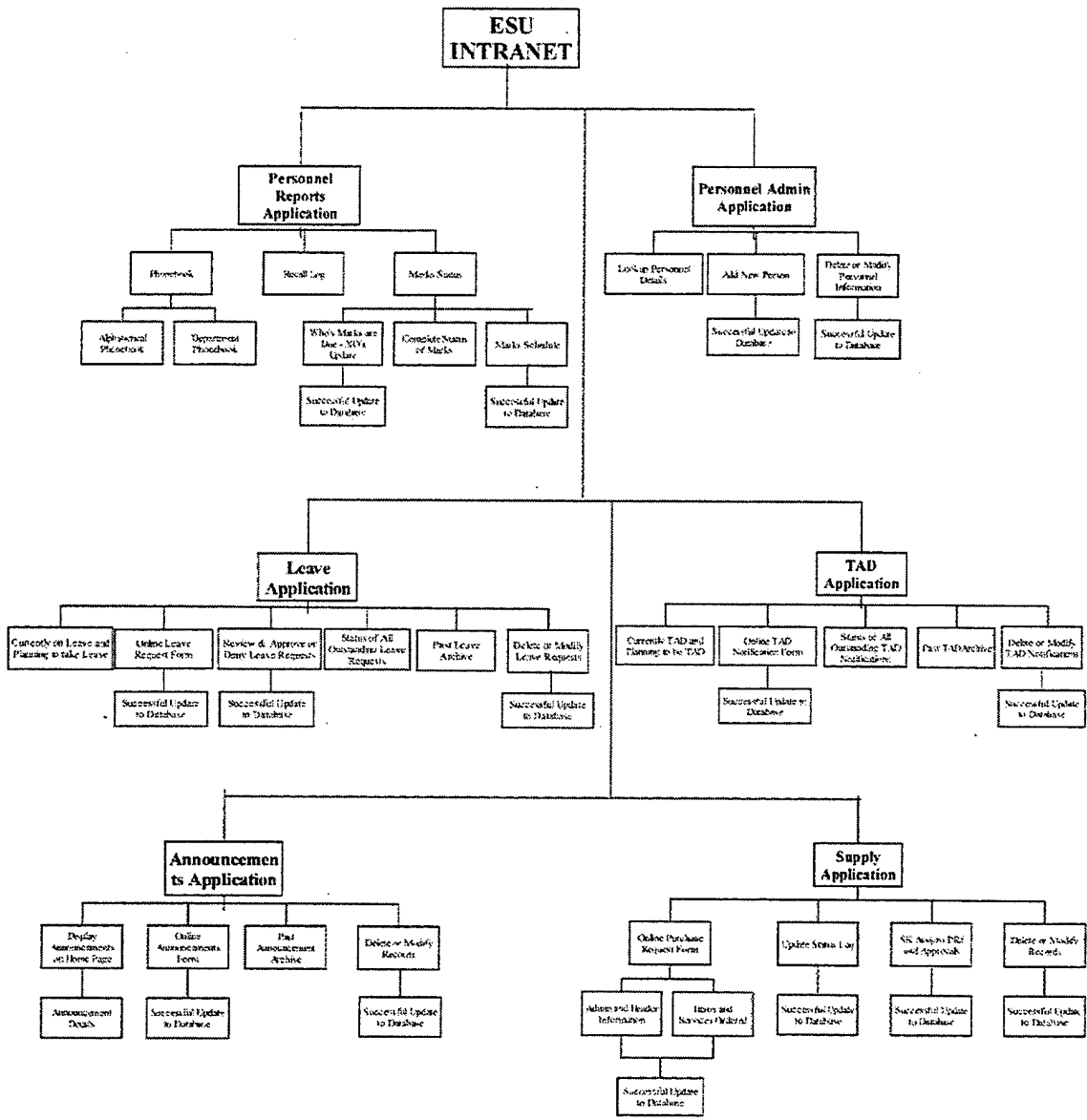

Figure 8.1 Intranet Navigation Structure

C. HOME PAGE

The ESU Alameda Intranet Home Page is the starting point for the Intranet. From the home page the user may login, view the most current and immediate content, or jump off to any of the various Intranet applications.

Home Page
Site Map

Intranet
Members Only

1. Databases:
[Personnel](#)
[Statbook](#)

2. Reports:
[Recall Log](#)
[Current Leave](#)
[Current TAD](#)
[Marks Due](#)

3. Online Forms:
[Leave Request](#)
[TAD Notification](#)
[Announcement](#)
[Purchase Request](#)

Extranet
Public Access

4. Public Info:
[Phonebook](#)

5. Departments:
[Contact and Info](#)
[CMTF Branch](#)
[IRMC Branch](#)
[Business Office](#)

6. Support:
[Intranet Help](#)

Electronic Support Unit Alameda Intranet

Welcome admin . You are logged in with security level admin

General Announcements

Announcement	Posted by
Picnic Today! 1400 details	Benhart, Ralph (LT) , 5/4/98

[Post a New Announcement](#)

Security

Intranet Login

Allows for access to pages intended for ESU members only. You MUST login to have access to databases.

Username:

Password:

Personnel on Leave Today

Name	Leave Period ends on:
Doolittle, Doctor (LT)	5/15/98 after 15 days.

[Leave Summary](#)

Personnel TAD Today

Name	TAD until	Where
Byrd, Scott (TC2)	5/10/98	USCGC RELIABLE
Fife, Barney (LT)	5/10/98	USCGC Bittersweet

[TAD Summary](#)

OERs/Marks Due in the next 31 Days

Who	When
O6	5/10/98
E7	6/1/98
CWO2	6/1/98

Whose Marks are Due

Click here to see the names and status of people whose marks are due.

Plan of the Week

 [Click Here!](#)

Today is 5/4/98

Figure 8.2 ESU Alameda Intranet Home Page

D. PERSONNEL APPLICATION

1. Introduction

The purpose of the Personnel Application is to track, forecast, and manage information about ESU Alameda personnel. The application interacts with the "phonebook" database. Access to this application is restricted to users who have logged in at the security session level "user". Access to the application includes the ability to view records, add new records and update existing records. Only users logged in at the highest security session level of "sec admin" may delete records.

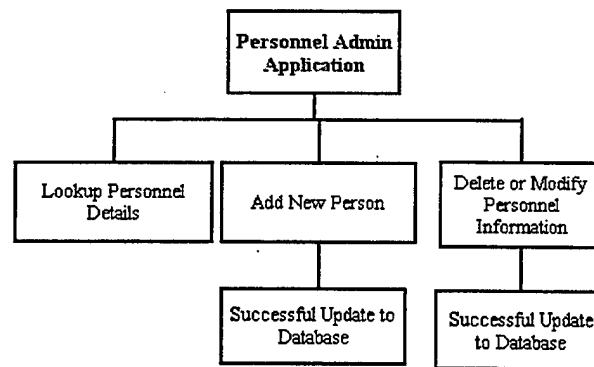

Figure 8.3 Personnel Administration Application Navigation Structure

2. Web Pages of the Personnel Application

a. **List of Web Page Figures:** The following table lists the names of the Web pages of this application and the corresponding figure numbers.

Web Page	Figure
Welcome Page	8.5
Lookup Personnel Details	8.6
Edit or Update Personnel	8.7
Add New Personnel On-line Form	8.8
Delete Personnel Record	8.9

Figure 8.4 Table of Web Pages and Corresponding Figures

Electronic Support Unit Alameda Intranet

Personnel Administration Web Database Application

Select a name from the pull down menu and click "Lookup". You will then be able to view, edit or update the data.

Baker, Jeff (ET1)

Lookup

Can't find your record? [Click Here to Add new personnel to the database](#)

Complete ESU Personnel Roster

Name	E-Mail	Department	
Baker, Jeff (ET1)	thehannahs@thegrid.net	ESU Business Services Branch	details edit delete
Bartlett, Rex (ETC)	thehannahs@thegrid.net	COTR Branch	details edit delete
Benhart, Ralph (LT)	thehannahs@thegrid.net	Detachment Oxnard	details edit delete
Bennett, Darwin (SKC)	thehannahs@thegrid.net	Business Services Branch	details edit delete
Brewster, Punkies (AM2)	thehannahs@thegrid.net	Detachment San Pedro	details edit delete
Byrd, Scott (TC2)	thehannahs@thegrid.net	IRM Branch	details edit delete
Cantu, Edward (TT3)	thehannahs@thegrid.net	IRM Branch	details edit delete
Clarke, Brian (TCCS)	thehannahs@thegrid.net	IRM Branch	details edit delete
DARDIS, DEAN (LT)	thehannahs@thegrid.net	Electronic Systems Branch	details edit delete
Doolittle, Doctor (LT)	thehannahs@thegrid.net	ESU Business Services	details edit delete
Enberg, Melvin (TC1)	thehannahs@thegrid.net	IRM Branch	details edit delete
Farms, Toad (LTJG)	me@esu.alameda.ca	Detachment San Pedro	details edit delete
Farms, 653456 (LTJG)	me@esu.alameda.ca	Detachment San Pedro	details edit delete
Farms, dfgh (LTJG)	me@esu.alameda.ca	Detachment San Pedro	details edit delete
Fife, Barney (LT)	thehannahs@thegrid.net	Detachment San Pedro	details edit delete
Fontaine, Trevor (TT3)	thehannahs@thegrid.net	IRM Branch	details edit delete
Gainer, Joanne (GS12)	thehannahs@thegrid.net	IRM Branch	details edit delete
Gardner, Bob (ETC)	thehannahs@thegrid.net	Contracted Source	details edit delete
George, Joe (ENS)	thehannahs@thegrid.net	COTR Branch	details edit delete
Gutierrez, Laura (ETC)	thehannahs@thegrid.net	COTR Branch	details edit delete
Gunther, Bobcat (LCDR)	thehannahs@thegrid.net	Detachment Oxnard	details edit delete
Hamlin, Chuck (ETC)	thehannahs@thegrid.net	SoCal Detachment Organization	details edit delete

Figure 8.5 Personnel Administration Welcome Page

b. **Welcome Page:** The Welcome Page presents the user with a list of all ESU Alameda personnel. Links are available for sending email, viewing more details, editing or deleting personnel records.

Personnel Details

LT Todd Hannah

SSN: 544699911

Work Information

Job Title: Webmaster
Department: Detachment San Pedro
Work Phone: () 1234567 ext:
E-Mail: thehannahs@thegrid.net

Home Information

Address: 459 Chips Way
Monterey CA 93955-5000
Home Phone: (408) 6580989
Beeper #, Cell Phone:

Administrative

Leave Requested

edit this record	fill out an online leave form	delete this record
Add new personnel	<input type="text" value="Baker, Jeff (ET1)"/> <input type="button" value="Lookup Person"/>	Personnel Administration Database

Figure 8.6 Personnel Details

c. Lookup Personnel Details: The main detail page provides more in depth detail of each person in the database. This page is accessed either by following the "details" link from the Personnel Database Welcome Page or by using any of the personnel lookup boxes found throughout the application.

Electronic Support Unit Alameda Intranet

Update or Edit Personnel Details

Rank	Rate	First Name	MI	Last Name	SSN
O3	LT	Todd	R	Hannah	544699911

Work Information

Job Title	Webmaster		
Department	Detachment San Pedro		
Work Phone	1234567	ext.	
E-Mail	thehannahs@thegrid.net		

Home Information

Address:			
Street	459 Chips Way		
City, State, Zip	Monterey	CA	93955-5000
Home Phone	408	6580989	
Beeper #	5675678		

[fill out an online leave form](#)

[delete this record](#)

[Add new personnel](#)

Baker, Jeff (ET1)

[Personnel Administration Database](#)

Figure 8.7 Edit Personnel Details

d. **Edit or Update Personnel:** This page allows users to edit or update their own record. It contains all of the same information found in the Lookup Details Page, but with text boxes available to submit updates. The Social Security Number (SSN) field is not updateable because that is the unique identifier, or primary key, of the database. If the SSN number is changed the record is essentially deleted.

Add new Personnel Record

Rank	Rate	First Name*	MI	Last Name*	SSN*
...					
Work Information					
Job Title					
Department*					
Work Phone*	408		ext:		
E-Mail	me@esu.alameda.ca				
Home Information					
Address:					
Street					
City, State, Zip					
Home Phone*					
Beeper #					
Administrative Information					
Intranet Username*	user				
Intranet Password*	****				
Confirm Password*	****				

* required fields

Add New Personnel **Reset**

Figure 8.8 Add New Personnel On-line Form

e. **Add New Personnel On-line Form:** This page is the form used to enter new personnel into the database. An Intranet username and password may also be assigned at this time. The default security access level on a new username is "user".

Electronic Support Unit Alameda Intranet

Successful Update to Personnel Details

LT Todd Hannah

SSN: 544699911

Work Information

Job Title Intranet Application Designer
Department Detachment San Pedro
Work Phone () 1234567 ext:
E-Mail thehannahs@thegrid.net

Home Information

Address: 459 Chips Way
 Monterey CA 93955-5000
Home Phone (408) 6580989
Beeper #, Cell Phone 5675678;

Administrative

Leave Requested

Finished. Proceed to Home Page

Figure 8.9 Successful Update to Database

f. Successful Update to Database: This page confirms that data was successfully entered into the database. A similar page is displayed after every successful submission of data to the Intranet databases.

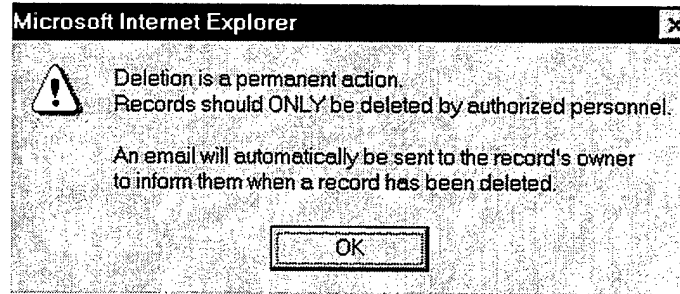

Figure 8.10 Warning Box for Deleting Records

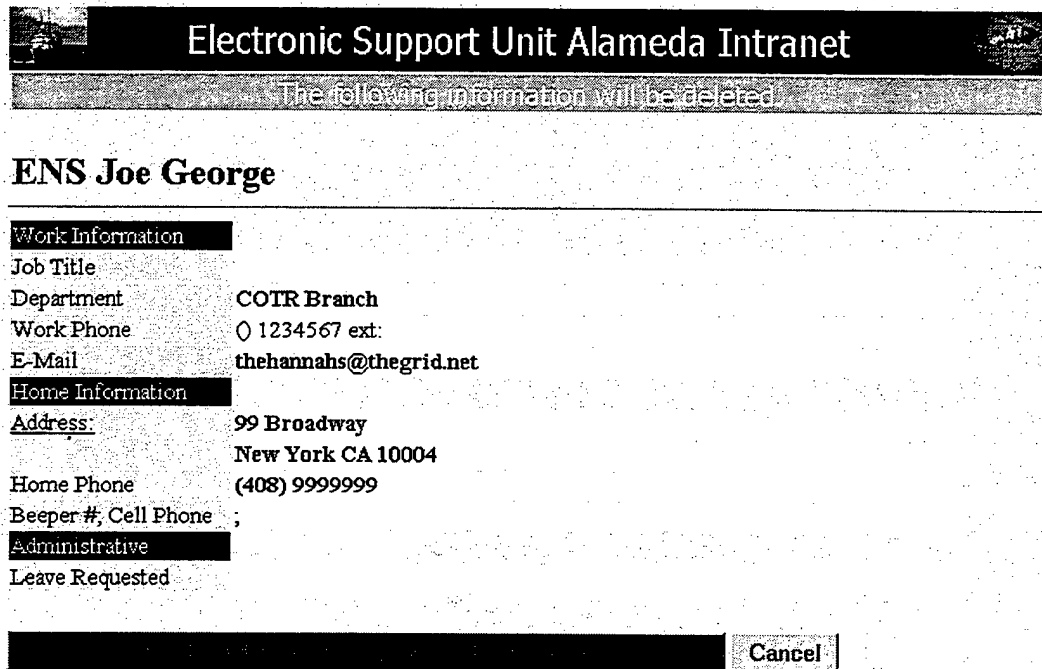

Figure 8.11 Delete a Record

g. Delete Records: Deleting information is handled with caution throughout the Intranet. First, the user must be logged in at an appropriate security access level. In the Personnel Application, the user must be logged in at security access level "sec admin" to even get to this page. When this page is called, a Warning Box (Figure 8.10) is immediately displayed. The user must click "OK" to continue. In order to perform a

deletion, the user must click on a large red button. Email is automatically forwarded to the record's owner informing them of the deletion.

E. LEAVE APPLICATION

1. Introduction

The purpose of the Leave Application is to provide better tracking of personnel for the ESU Command and its members. This application addresses one of the Command's top goals as identified during the Analysis Phase. Users who have logged in at security access level "user" have full access to the Leave Application. Full access allows users to view, add, update and delete records.

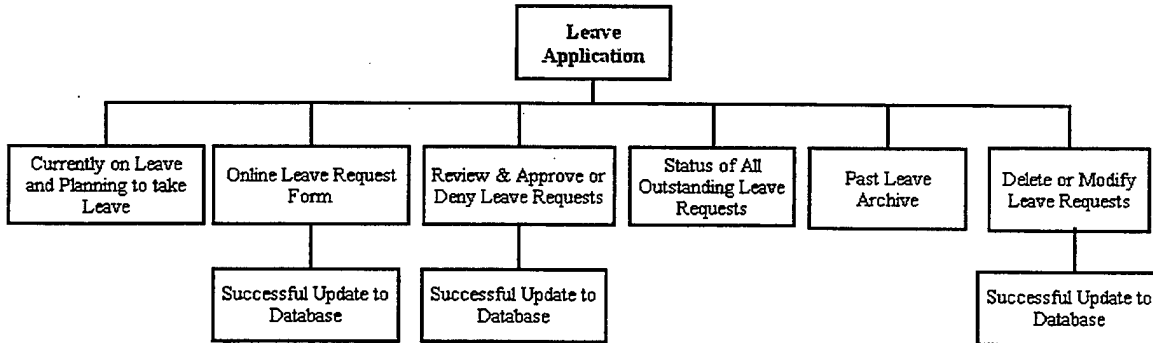

Figure 8.12 Leave Admin Application Navigation Structure

2. Web Pages of the Leave Application

a. **List of Web Page Figures:** The following table lists the names of the Web pages of this application and the corresponding figure numbers.

Web Page	Figure
Home Page (with Leave Application highlighted)	8.14
On-line Leave Request Form	8.15
Leave Approval Chain	8.16
Status of Pending Leave Requests	8.17
Summary of Leave Information	8.18
Details of a Leave Request	8.19
Past Leave Archive	8.20

Figure 8.13 Table of Web Pages and Corresponding Figures

Electronic Support Unit Alameda Intranet

Welcome admin . You are logged in with security level admin

General Announcements

Announcement	Posted by
ESU Picnic Today! details	Farms, Toad (LTJG), 4/6/98

[Post a New Announcement](#)

Personnel on Leave Today

Name	Leave Period ends on:
McClain, Chuck (ETC)	4/15/98 after 7 days.
Rauschkolb, Mark (TT2)	5/1/98 after 24 days.

[Leave Summary](#)

Security

Intranet Login

Allows for access to pages intended for ESU members only. You MUST login to have access to databases.

Username:

Password:

Personnel TAD Today

Name	TAD until	Where
Byrd, Scott (TC2)	5/10/98	USCGC RELIABLE
Nelson, Patrick (LT)	4/9/98	RTC Yorktown
Murray, John (TC1)	4/17/98	USCGC SHERMAN

[TAD Summary](#)

OERs/Marks Due in the next 31 Days

Who	When
E3	5/1/98
CWO3	5/1/98
O1	5/1/98

Whose Marks are Due

[Click here to see the names and status of people whose marks are due](#)

Plan of the Week

 [Click Here!](#)

Today is 4/6/98

Figure 8.14 Home Page with Leave Application Highlighted

b. Home Page: The Leave Application is highlighted here on the Home Page. It shows the user which personnel who are away on leave for the day.

Electronic Support Unit Alameda Intranet

Online Leave Request Form

Name: *

Leave Address:
Street *
City, State, Zip *
Leave Phone *

Begin Leave * (mm/dd/yyyy)
End Leave *
Number of Days on Leave
Reason for Request

My e-mail address is: *
First Approval
Second Approval
Final Approval

* Required Fields:

When this form is submitted, an email notification of your leave request will be sent along the approval chain of command.

Can't find your record? [Click Here to Add New personnel to the database.](#)

[Currently on Leave](#) [Review, Approve/Deny Pending Leave Requests \(restricted access\)](#) [Status of All Pending Leave Request](#) [Past Leave Archive](#) [Online Leave Request Form](#)

Figure 8.15 On-line Leave Request Form

c. **On-line Form Leave Request:** This page is a form for a user to request leave.

The information is entered into the database for action.

Electronic Support Unit Alameda Intranet

Review Pending Leave Requests

Restricted Access Page: Only make a selection in the block that you are Approval Authority for. Each person in the approval chain will review these requests and click the Submit button for each individual request that is reviewed. This is like a signature so don't "sign" someone else's name in another block. (i.e. Only select Submit in the Final Approval block if you are the Final Approval Authority).

Name	When	Why	Immediate Supervisor	Department Head	Final Approval
ETC McClain	4/6/98 thru 4/15/98 for 7 days leave.	To visit mom.	ETC Hamlin	LT DARDIS	LCDR Hernandez
			approved	approved	Not Yet Reviewed
Click here to view more details about this Leave Request			<input type="radio"/> Approved <input type="radio"/> Disapproved <input type="button" value="Submit"/>	<input type="radio"/> Approved <input type="radio"/> Disapproved <input type="button" value="Submit"/>	<input checked="" type="radio"/> Approved <input type="radio"/> Disapproved <input type="button" value="Submit"/>
Name	When	Why	Immediate Supervisor	Department Head	Final Approval
IT2 Rauschkolb	4/6/98 thru 5/1/98 for 24 days leave.	To vacation with my son	ETC Hamlin	LT Keyes	LCDR Hernandez
			Not Yet Reviewed	Not Yet Reviewed	Not Yet Reviewed
Click here to view more details about this Leave Request			<input type="radio"/> Approved <input type="radio"/> Disapproved <input type="button" value="Submit"/>	<input type="radio"/> Approved <input type="radio"/> Disapproved <input type="button" value="Submit"/>	<input type="radio"/> Approved <input type="radio"/> Disapproved <input type="button" value="Submit"/>

[Currently on Leave](#)
 [Review, Approve, Deny Pending Leave Requests \(Restricted access\)](#)
 [Status of All Pending Leave Requests](#)
 [Past Leave Archive](#)
 [Online Leave Request Form](#)

Figure 8.16 Leave Approval Chain

d. Leave Approval Chain: Supervisors may review, approve, or deny on-line leave requests in this area. The page is restricted to supervisors by security level.

Electronic Support Unit Alameda Intranet

Status of Pending Leave Requests

Not Yet Reviewed Leave Requests

Name	Leave Period and Duration	Immediate Supervisor: Status	Department Head: Status	Final Approval: Status	
Reagen, Danielle (AEC)	4/8/98 thru 4/10/98 for 2 days leave.	LTJG Rausch	LT Benhart	LCDR Hernandez	details APPROVE delete
		Not Yet Reviewed	Not Yet Reviewed	Not Yet Reviewed	

Approved Leave Requests

Name	Leave Period and Duration	Immediate Supervisor: Status	Department Head: Status	Final Approval: Status	
Doolittle, Doctor (LT)	5/1/98 thru 5/15/98 for 15 days leave.	LT Fife	LT Benhart	LCDR Hernandez	details APPROVE delete
		approved	approved	approved	
McClain, Chuck (ETC)	4/6/98 thru 4/15/98 for 7 days leave.	ETC Hamlin	LT DARDIS	LCDR Hernandez	details APPROVE delete
		approved	approved	approved	
Rauschkolb, Mark (TT2)	4/6/98 thru 5/1/98 for 24 days leave.	ETC Hamlin	LT Keyes	LCDR Hernandez	details APPROVE delete
		Not Yet Reviewed	Not Yet Reviewed	approved	

Disapproved Leave Requests

Name	Leave Period and Duration	Immediate Supervisor: Status	Department Head: Status	Final Approval: Status	
Seagar, Bob (AD2)	4/7/98 thru 5/1/98 for 23 days leave.	ETC Hamlin	LT Keyes	LCDR Hernandez	details APPROVE delete
		disapproved	disapproved	disapproved	

Currently on Leave	Review, Approve/Deny Pending Leave Requests (restricted access)	Status of All Pending Leave Request	Past Leave Archive	Online Leave Request Form
------------------------------------	---	---	------------------------------------	---

Figure 8.17 Status of all Pending Leave Requests

e. **Status of Pending Leave Requests:** This page contains the current approval status of all leave requests entered in the database.

Summary of Personnel Leave Information Currently on Leave (approved)

Name	Leave Period and Duration	
McClain, Chuck (ETC)	4/6/98 thru 4/15/98 for 7 days leave.	details delete
Rauschkolb, Mark (IT2)	4/6/98 thru 5/1/98 for 24 days leave.	details delete

Requested Current Leave (not yet reviewed or denied)

Name	Leave Period and Duration
------	---------------------------

Planning to Begin Leave within the Next 30 Days

Name	Leave Period and Duration	
Doolittle, Doctor (LT)	5/1/98 thru 5/15/98 for 15 days leave.	details APPROVE delete
Seagar, Bob (AD2)	4/7/98 thru 5/1/98 for 23 days leave.	details APPROVE delete

Planning to Begin Leave Over 30 Days from Today

Name	Leave Period and Duration
------	---------------------------

Currently on Leave	Review, Approve/Deny Pending Leave Requests (restricted access)	Status of All Pending Leave Request	Past Leave Archive	Online Leave Request Form
------------------------------------	---	---	------------------------------------	---

Figure 8.18 Summary of Current and Upcoming Leave

f. **Summary of Leave Information:** Users may check up on the status of their own leave requests or see others at this page. The application displays who is currently on leave, who will be on leave and contains an archive of who was on leave. Users may also follow links to view, edit or delete details of their requests from here.

Details of LT Doolittle's Leave Request

LT Doctor Doolittle

Leave Address:

Street: Mayberry Lane
 Monterey
 City, State: , CA
 Leave Phone: (888) 888-8889

Begin Leave: 5/1/98
 End Leave: 5/15/98
 Number of Days on Leave: 15
 Reason for Request: To tend the sheep

e-mail address is:	thehannahs@thegrid.net	Approval Status
First Approval	LT Fife	approved
Second Approval	LT Benhart	approved
Final Approval Authority	LCDR Hernandez	approved

Currently on Leave	Review, Approve/Deny Pending Leave Requests (restricted access)	Status of All Pending Leave Request	Past Leave Archive	Online Leave Request Form
------------------------------------	---	---	------------------------------------	---

Figure 8.19 Details of a Leave Request

g. Details of a Leave Request: This page displays the details of a leave request in the database.

Electronic Support Unit Alameda Intranet

This archive displays all leave taken one year from today's date. Today is 5/13/98.

One Year Leave Archive by Last Name [\(View by Date\)](#)

Name	Duration	Began Leave	Leave Ended
Bernhart, Ralph (LT)	1 days	1/1/98	1/2/98
McClain, Chuck (ETC)	7 days	4/6/98	4/15/98
Reagen, Danielle (AEC)	2 days	4/8/98	4/10/98
Seagar, Bob (AD2)	23 days	4/7/98	5/1/98
Weeks, Steven (ETC)	7 days	3/28/98	4/5/98

[Back to top](#)

One Year Leave Archive by Date [\(View by Person\)](#)

Leave Ended	Began Leave	Duration	Name
5/1/98	4/7/98	23 days	Seagar, Bob (AD2)
4/15/98	4/6/98	7 days	McClain, Chuck (ETC)
4/10/98	4/8/98	2 days	Reagen, Danielle (AEC)
4/5/98	3/28/98	7 days	Weeks, Steven (ETC)
1/2/98	1/1/98	1 days	Bernhart, Ralph (LT)

[Back to top](#)

Figure 8.20 Past Leave Archive

h. Past Leave Archive: This page displays the names of all personnel who have taken leave over the past year. The archive is sorted both by name and by date. A similar archive page is used for the TAD Application, the Announcements Application, and the Supply Application,

F. TAD APPLICATION

1. Introduction

The purpose of the TAD Application is to provide better tracking of personnel for the ESU Command and its members. This application addresses one of the Command's top goals as identified during the Analysis Phase. Users who have logged in at security access level "user" have full access to the TAD Application. Full access allows users to view, add, update and delete records.

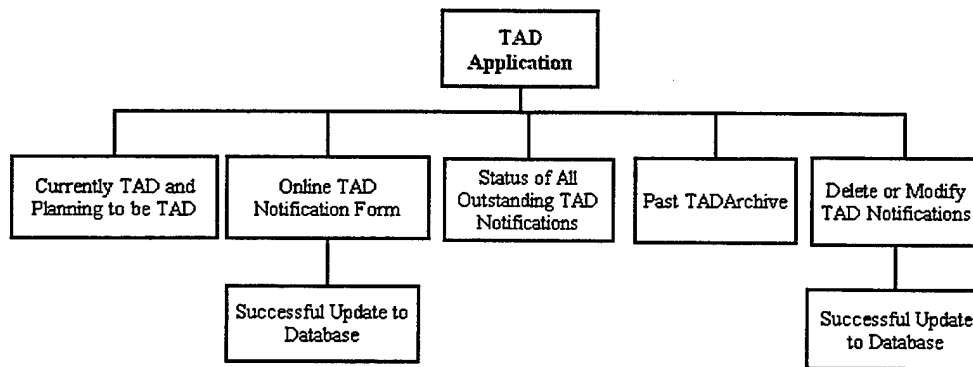

Figure 8.21 TAD Application Navigation Structure

2. Web Pages of the TAD Application

a. List of Web Page Figures: The following table lists the names of the Web pages of this application and the corresponding figure numbers. Some pages, which were included as parts of the Leave Application, are nearly identical in the TAD Application. Screen shots of these pages, such as the Past TAD Archive page, are not shown.

Web Page	Figure
Home Page (with TAD Application highlighted)	8.23
On-line TAD Notification Form	8.24
Summary of TAD Information	8.25

Figure 8.22 Table of Web Pages and Corresponding Figures

Electronic Support Unit Alameda Intranet

Welcome admin . You are logged in with security level admin

General Announcements		Personnel on Leave Today														
<table border="1" style="width: 100%; border-collapse: collapse;"> <thead> <tr> <th style="text-align: left;">Announcement</th> <th style="text-align: left;">Posted by</th> </tr> </thead> <tbody> <tr> <td>Picnic Today! 1400 details</td> <td>Benhart, Ralph (LT), 5/4/98</td> </tr> </tbody> </table> <p style="text-align: center;">Post a New Announcement</p>	Announcement	Posted by	Picnic Today! 1400 details	Benhart, Ralph (LT), 5/4/98	<table border="1" style="width: 100%; border-collapse: collapse;"> <thead> <tr> <th style="text-align: left;">Name</th> <th style="text-align: left;">Leave Period ends on:</th> </tr> </thead> <tbody> <tr> <td>Doolittle, Doctor (LT)</td> <td>5/15/98 after 15 days</td> </tr> </tbody> </table> <p style="text-align: center;">Leave Summary</p>	Name	Leave Period ends on:	Doolittle, Doctor (LT)	5/15/98 after 15 days							
Announcement	Posted by															
Picnic Today! 1400 details	Benhart, Ralph (LT), 5/4/98															
Name	Leave Period ends on:															
Doolittle, Doctor (LT)	5/15/98 after 15 days															
Security		Personnel TAD Today														
<div style="border: 1px solid black; padding: 5px;"> <p style="text-align: center;">Intranet Login</p> <p style="font-size: small;">Allows for access to pages intended for ESU members only. You MUST login to have access to databases.</p> <table style="width: 100%; border-collapse: collapse;"> <tr> <td style="border: 1px solid black; padding: 2px;">Username:</td> <td style="border: 1px solid black; padding: 2px;">user</td> </tr> <tr> <td style="border: 1px solid black; padding: 2px;">Password:</td> <td style="border: 1px solid black; padding: 2px;"></td> </tr> <tr> <td colspan="2" style="border: 1px solid black; padding: 2px; text-align: center;">Login</td> </tr> </table> </div>	Username:	user	Password:		Login		<table border="1" style="width: 100%; border-collapse: collapse;"> <thead> <tr> <th style="text-align: left;">Name</th> <th style="text-align: left;">TAD until</th> <th style="text-align: left;">Where</th> </tr> </thead> <tbody> <tr> <td>Byrd, Scott (TC2)</td> <td>5/10/98</td> <td>USCGC RELIABLE</td> </tr> <tr> <td>Fife, Barney (LT)</td> <td>5/10/98</td> <td>USCGC Bittersweet</td> </tr> </tbody> </table> <p style="text-align: center;">TAD Summary</p>	Name	TAD until	Where	Byrd, Scott (TC2)	5/10/98	USCGC RELIABLE	Fife, Barney (LT)	5/10/98	USCGC Bittersweet
Username:	user															
Password:																
Login																
Name	TAD until	Where														
Byrd, Scott (TC2)	5/10/98	USCGC RELIABLE														
Fife, Barney (LT)	5/10/98	USCGC Bittersweet														

Figure 8.23 Home Page with TAD Application Highlighted

b. Home Page with TAD Application Highlighted: The Leave Application is highlighted here on the Home Page. It shows the user which personnel who are away on leave for the day.

Electronic Support Unit Alameda Intranet

Online Temporary Assigned Duty (TAD) Notification Form

If you are going to be TAD, please fill out this form.

Who	<input type="text" value="Fife, Barney (LT)"/>
Leaving	<input type="text" value="5/4/98"/>
Returning	<input type="text" value="5/10"/>
Where: (Command Name)	<input type="text" value="USCGC Bittersweet"/>
Reason for TAD	<input type="text" value="To fix the radar."/>
<input type="button" value="Submit TAD Form"/> <input type="button" value="Reset"/>	

Can't find your record? [Click Here to Add New personnel to the database.](#)

[Current and Upcoming TAD](#) [TAD Notification Form](#) [Past TAD Archive](#)

Figure 8.24 On-line TAD Notification Form

c. **On-line TAD Notification Form:** This page is a form for a user to notify the Command that they will be away TAD. The information is entered into the database.

Summary of TAD Information

Currently TAD

Name	TAD Period	Where	Reason	
Byrd, Scott (TC2)	4/6/98 thru 5/10/98	USCGC RELIABLE	Fix the radar	details delete
Fife, Barney (LT)	5/4/98 thru 5/10/98	USCGC Bittersweet	To fix the radar.	details delete

Planning to Begin TAD within the Next 30 Days

Name	TAD Period	Where	Reason
------	------------	-------	--------

Planning to Begin TAD Over 30 Days from Today

Name	TAD Period	Where	Reason	
Wallace, Tony (GS9)	6/8/98 thru 6/10/98	NPS	2 day seminar on Intranets	details delete

[Current and Upcoming TAD](#)

[TAD Notification Form](#)

[Past TAD Archive](#)

Figure 8.25 Summary of TAD Information

d. **Summary of TAD Information:** The application displays lists of personnel who are currently TAD and who will be TAD in the future. Users may also follow links to view, edit or delete details of their notifications from here.

G. ANNOUNCEMENTS APPLICATION

1. Introduction

The purpose of the Announcements Application is to provide better communications throughout the ESU. It also empowers employees to make broadcast announcements instantly.

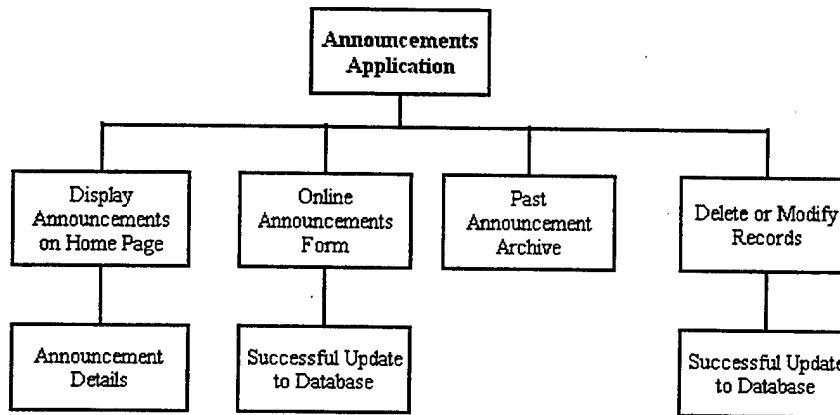

Figure 8.26 Announcement Application Navigation Structure

2. Web Pages of the Announcements Application

a. List of Web Page Figures: The following table lists the names of the Web pages of this application and the corresponding figure numbers. The application also has pages for updating announcements, deleting announcements and viewing a past announcement archive. Screenshots of these pages are not provided because they are similar to the ones from other applications.

Web Page	Figure
Home Page (with Announcements Application highlighted)	8.28
Announcements Details	8.29
On-line Announcement Form	8.30

Figure 8.27 Table of Web Pages and Corresponding Figures

Electronic Support Unit Alameda Intranet

Welcome admin . You are logged in with security level admin

General Announcements		Personnel on Leave Today																	
Announcement	Posted by	Name	Leave Period ends on:																
Picnic Today! 1400 details	Benhart, Ralph (LT), 5/4/98	Doolittle, Doctor (LT)	5/15/98 after 15 days.																
Post a New Announcement		Leave Summary																	
Security		Personnel TAD Today																	
<table border="1" style="margin: auto; border-collapse: collapse;"> <thead> <tr> <th colspan="2" style="text-align: center;">Intranet Login</th> </tr> </thead> <tbody> <tr> <td colspan="2" style="text-align: center; font-size: small;">Allows for access to pages intended for ESU members only. You MUST login to have access to databases.</td> </tr> <tr> <td style="text-align: right;">Username:</td> <td><input type="text" value="user"/></td> </tr> <tr> <td style="text-align: right;">Password:</td> <td><input type="password"/></td> </tr> <tr> <td colspan="2" style="text-align: center;"><input type="button" value="Login"/></td> </tr> </tbody> </table>		Intranet Login		Allows for access to pages intended for ESU members only. You MUST login to have access to databases.		Username:	<input type="text" value="user"/>	Password:	<input type="password"/>	<input type="button" value="Login"/>		<table border="1" style="margin: auto; border-collapse: collapse;"> <thead> <tr> <th style="text-align: left;">Name</th> <th style="text-align: left;">TAD until</th> <th style="text-align: left;">Where</th> </tr> </thead> <tbody> <tr> <td>Byrd, Scott (TC2)</td> <td>5/10/98</td> <td>USCGC RELIABLE</td> </tr> </tbody> </table>		Name	TAD until	Where	Byrd, Scott (TC2)	5/10/98	USCGC RELIABLE
Intranet Login																			
Allows for access to pages intended for ESU members only. You MUST login to have access to databases.																			
Username:	<input type="text" value="user"/>																		
Password:	<input type="password"/>																		
<input type="button" value="Login"/>																			
Name	TAD until	Where																	
Byrd, Scott (TC2)	5/10/98	USCGC RELIABLE																	
		TAD Summary																	

Figure 8.28 Home Page with Announcements Application Highlighted

b. Home Page with Announcements Application Highlighted: The

Announcements Application is highlighted here on the Home Page. This is where the announcement headline is broadcast. A person follows the link for more details of an announcement.

Announcement Details

Details of that announcement are as follows:

Headline: **Picnic Today! 1400**
Details: The ESU Picnic will be held on the front lawn at 1300. Volleyball net will be available.
Posted on: 5/4/98
Post expires: 5/5/98
Point of Contact: Benhart, Ralph (LT)

[Post a New Announcement](#)

[View Past Announcement Archive](#)

[Delete this Announcement](#)

Figure 8.29 Announcement Details

c. Announcement Details: This page contains further details of the announcement headline posted on the Home Page.

Electronic Support Unit Alameda Intranet

Add a new Announcement to the Home Page

These announcements are for general all-hands broadcast and will be visible to ANYONE visiting the ESU Alameda Home Page. Bear this in mind when making a post and keep it professional. Any validated ESU Alameda Intranet user may post announcements.

Point of Contact	<input type="text" value="Benhart, Ralph (LT)"/>
Date of post	<input type="text" value="5/4/98"/>
Date post expires and removed from Home Page	<input type="text" value="5/5/98"/>
Announcement Headline for Home Page: (Please limit to one or two lines without carriage returns.)	<input type="text" value="Picnic Today! 1400"/>
Details of Announcement: (Only headline visible on Home Page. Details upon following hyperlink. No carriage returns.)	<input type="text" value="The ESU Picnic will be held on the front lawn at 1300. Volleyball net will be available."/>

[Post Announcement to ESU Alameda Home Page](#)

[Post a New Announcement](#)

[View Past Announcement Archive](#)

Figure 8.30 On-line Announcement Form

d. **On-line Announcement Form:** This form is used to post an on-line announcement. Anyone in the Command who has logged on to the Intranet is able to broadcast an announcement using this form.

H. PERSONNEL REPORTS APPLICATION

1. Introduction

The purpose of the Personnel Reports Application is to provide better communications throughout the ESU. It contains reports for information the ESU Command considers vital.

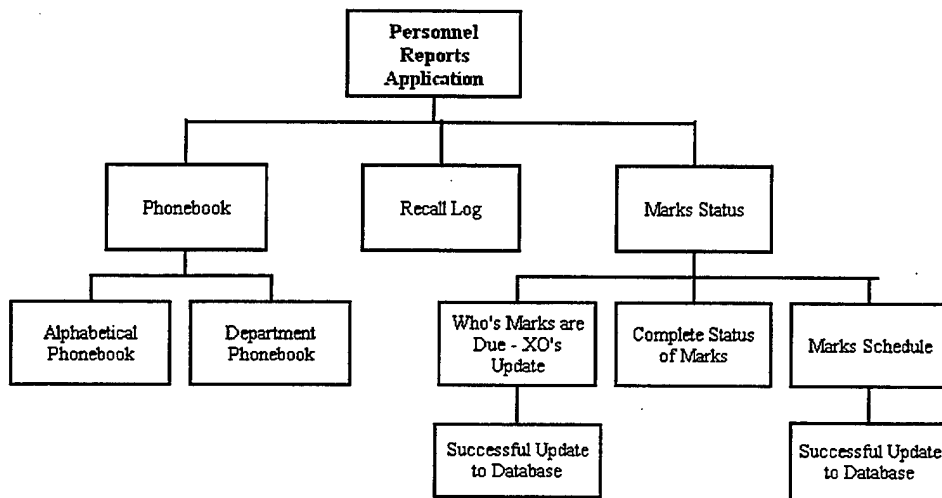

Figure 8.31 Personnel Reports Application Navigation Structure

2. Web Pages of the Personnel Reports Application

a. **List of Web Page Figures:** The following table lists the names of the Web pages of this application and the corresponding figure numbers.

Web Page	Figure
Recall Log	8.33
Department Phonebook	8.34
Alphabetical Phonebook	8.35
Marks Due this Month	8.36
Status of all Marks Due	8.37
Complete Marks Schedule	8.38
Edit Marks Schedule	8.39

Figure 8.32 Table of Web Pages and Corresponding Figures

Electronic Support Unit Alameda Intranet

Recall Log

Work Phone & E-Mail Listings - Alphabetical

Work Phone & E-Mail Listings - by Department

Recall Log is FOR OFFICIAL USE ONLY

Name	Address	Home Phone #	Beeper #
Baker, Jeff (ET1)	Mulberry Way, Alameda(CA)	(408) 8768768	
Bartlett, Rex (ETC)	Friar Tuck Lane, Alameda (CA)	(408) 980909	
Benhart, Ralph (LT)	3568B Jurassic Park Ave., Monterey(CA)	() 6588958	
Bennett, Darvin (SKC)	Stourport Av, Alameda(CA)	(408) 8768768	
Brewster, Punkies (AM2)	20 Punky way, Seaside(CA)	() 3938444	546654564
Byrd, Scott (TC2)	, (CA)	(408)	
Cantu, Edward (TT3)	thers, (CA)	(408)	
Clarke, Brian (TCCS)	, (CA)	(408)	
DARDIS, DEAN (LT)	222 RAMAGEN DR, GULA GULA (CA)	(408) 3932563	
Doolittle, Doctor (LT)	Animal Way, Pacific Grove(CA)	(408) 6582074	

Figure 8.33 Recall Log

b. Recall Log: The Recall Log is used to display the home addresses and phone numbers of ESU personnel. Its primary purpose is, in case of a general recall, for the duty officers to be able to locate personnel who are off duty.

Electronic Support Unit Alameda Intranet

Phone & E-Mail Listings - by Department



[Click Here](#) for Phone & E-Mail Listings - Listed Alphabetically

[Electronic Systems Branch](#) | [IRM Branch](#) | [COTR Branch](#) | [ESU Business Services Branch](#) | [Detachment Ozark](#) | [Contracted Source](#) | [Other](#) | [Detachment San Pedro](#) | [Detachment San Diego](#)

Commanding Officer:	Work Phone #	email
Lane, Ed (CDR)	(510) 437-3923:	thehannahs@thegrid.net
Executive Officer:		
Hernandez, Mark (LCDR)	(510) 437-3921:	thehannahs@thegrid.net

Electronic Systems Branch

Name	Job Title	Work Phone #	email
DARDIS, DEAN (LT)	DEANER OF WINNERS	(408) 393-1404:	thehannahs@thegrid.net
Jackson, Carol (ASM3)		Ø 1234567:	thehannahs@thegrid.net
Joes, Stalin (CDR)	Dictator	(408) 79698 : 8970	thehannahs@thegrid.net
Olsen, Chris (CWO2)	Vessels Section (WHEC, WMEC, WLB)	(510) 437-3913:	thehannahs@thegrid.net
Rausch, Nathan (LTJG)	Elec Sys Branch Chief	(510) 437-5351:	thehannahs@thegrid.net
Reagen, Danielle (AEC)		Ø 1234567:	thehannahs@thegrid.net
Reichert, Tracy (ET2)	Pipeliners Supervisor / DGPS	(510) 437-5894:	thehannahs@thegrid.net
Smith, Malcom (LTJG)		Ø 1234567:	thehannahs@thegrid.net
Stokes, John (LT)	Kodiak IRM Branch Chief	(408) 1211234:	thehannahs@thegrid.net
Welden, John (CWO4)	Shore Section (WPB)	(510) 437-3795:	thehannahs@thegrid.net

[Back to Top](#)

IRM Branch

Name	Job Title	Work Phone #	email
Byrd, Scott (TC2)	RSM	(707) 839-6109:	thehannahs@thegrid.net
Canhu, Edward (TT3)	TT Shop	(510) 437-3290:	thehannahs@thegrid.net
Clarke, Brian (TCCS)	D11 Frequency Manager	(510) 437-5305:	thehannahs@thegrid.net
Erberg, Melvin (TC1)	RSM	(415) 399-3405:	thehannahs@thegrid.net
Fontaine, Trevor (TT3)	TT Shop	(510) 437-3290:	thehannahs@thegrid.net

Figure 8.34 Department Phonebook

c. Department Phonebook: This phonebook is organized by department. If the departments change, the phonebook structure will change dynamically. For example, users may add new departments to the database and the phonebook will update itself automatically. It doesn't need to be redesigned.

Electronic Support Unit Alameda Intranet

Phone & E-Mail Directory - Alphabetical



[Click Here](#) for Phone & E-Mail Listings - Listed by Department

[A](#) [B](#) [C](#) [D](#) [E](#) [F](#) [G](#) [H](#) [I](#) [J](#) [K](#) [L](#) [M](#) [N](#) [O](#) [P](#) [Q](#) [R](#) [S](#) [T](#) [U](#) [V](#) [W](#) [X](#) [Y](#) [Z](#)

A

Name	Job Title	Department	Work Phone #	email
------	-----------	------------	--------------	-------

[Back to Top](#)

B

Name	Job Title	Department	Work Phone #	email
Baker, Jeff (ET1)	TT Shop	ESU Business Services Branch	(510) 437-5668:	thehannahs@thegrid.net
Bartlett, Rex (ETC)	Alt-COTR	COTR Branch	(510) 437-3874: 9999	thehannahs@thegrid.net
Benhart, Ralph (LT)	Network Engineer PCS	Detachment Oxnard	() 1234567:	thehannahs@thegrid.net
Bennett, Darwin (SKC)	Storekeeper	Business Services Branch	(510) 437-5301:	thehannahs@thegrid.net
Brewster, Punkies (AM2)	Tech Support	Detachment San Pedro	(515) 1234567:	thehannahs@thegrid.net
Byrd, Scott (TC2)	RSM	IRM Branch	(707) 839-6109:	thehannahs@thegrid.net

[Back to Top](#)

C

Name	Job Title	Department	Work Phone #	email
Cantu, Edward (TT3)	TT Shop	IRM Branch	(510) 437-3290:	thehannahs@thegrid.net
Clarke, Brian (TCCS)	D11 Frequency Manager	IRM Branch	(510) 437-5305:	thehannahs@thegrid.net

[Back to Top](#)

Figure 8.35 Alphabetical Phonebook

d. **Alphabetical Phonebook:** This phonebook is arranged alphabetically by last name.

Electronic Support Unit Alameda Intranet

Marks Due this Month

Rank/ Rate	Name	Marks Due by	Current Status	XO to Update Status (For XO's use only!)	
CWO2	Hannah, Leesa	6/1/98	finished	Finished Not Finished	<input type="checkbox"/> <input type="checkbox"/> <input type="button" value="Update"/>
AEC	Reagen, Danielle	6/1/98	Not Finished	Finished Not Finished	<input type="checkbox"/> <input type="checkbox"/> <input type="button" value="Update"/>
TCCS	Clarke, Brian	6/1/98	Not Finished	Finished Not Finished	<input type="checkbox"/> <input type="checkbox"/> <input type="button" value="Update"/>
ATC	Robertson, Jill	6/1/98	Not Finished	Finished Not Finished	<input type="checkbox"/> <input type="checkbox"/> <input type="button" value="Update"/>

Marks Due Next Month

Rank/Rate	Name	Marks Due
AE1	Louie, Baby	7/1/98
AM1	Johns, Sherri	7/1/98

[Complete Marks Status Page](#)

[Marks Due](#)

[Complete OER/Marks Schedule](#)

Figure 8.36 Marks Due this Month

e. **Marks Due this Month:** This page is primarily for the Executive Officer's benefit. It provides the XO with the ability to quickly determine whose marks must be completed and when. It allows him to update the status of when the marks were last completed. This application addresses one of the XO's top goals as determined during the analysis phase.

Electronic Support Unit Alameda Intranet

Status of Marks

Name	Marks Status	Date of Last Update by XO
Farms, Toad (LTJG)		
Farms, dfgh (LTJG)		
Farms, 653456 (LTJG)		
Joes, Stalin (CDR)		
DARDIS, DEAN (LT)	finished	3/26/98
Lane, Ed (CDR)	finished	3/26/98
Welden, John (CWO4)	finished	3/26/98
George, Joe (ENS)	finished	4/1/98
Hannah, Leesa (CWO2)	finished	5/4/98
Baker, Jeff O	Not Finished	
Bartlett, Rex (ETC)	Not Finished	

Figure 8.37 Status of All Marks Due

f. Status of all Marks Due: This page displays the status of everyone's marks. It also indicates the date when the last update occurred.

Electronic Support Unit Alameda Intranet

Enlisted Marks and OERs Schedule by Date Due (view by Rank/Rate)

Rate/Rank	Marks are Due by	
Seaman (E2)	1/1/98	edit
Seaman (E1)	2/1/98	edit
LTJG (O2)	2/1/98	edit
LCDR (O4)	3/1/98	edit
LT (O3)	3/14/98	edit
CDR (O5)	4/1/98	edit
CWO4 (CWO4)	4/1/98	edit
Seaman (E3)	5/1/98	edit
ENS (O1)	5/1/98	edit
CWO3 (CWO3)	5/1/98	edit
CAPT (O6)	5/10/98	edit
Chief Petty Officer (E7)	6/1/98	edit
CWO2 (CWO2)	6/1/98	edit
First Class Petty Officer (E6)	7/1/98	edit
CWO1 (CWO1)	7/15/98	edit
Second Class Petty Officer (E5)	10/1/98	edit
Third Class Petty Officer (E4)	11/1/98	edit

[Back to Top](#)

Enlisted Marks and OERs Schedule by Rank/Rate (view by Date Due)

Figure 8.38 Complete Marks Schedule

g. Complete Marks Schedule: This page displays the dates when a particular rank or rate's marks are due. LTJG marks, for example, are due by February 1st according to this schedule.

Edit Enlisted Marks and OERs Schedule

Rate/Rank	Marks Currently Due by	Enter New Date Marks are Due by (mm/dd/yy)
CWO2 (CWO2)	6/1/98	<input type="text"/> <input type="button" value="Submit"/>

[Return to Review of Marks Due](#)

[Complete Marks Status Page](#) [Marks Due](#) [Complete OER/Marks Schedule](#)

Figure 8.39 Edit Marks Schedule

h. Edit Marks Schedule: The schedule of when marks are due can be edited using this form. Sometimes the Coast Guard will make changes to the marks schedule.

I. SUPPLY APPLICATION

1. Introduction

The purpose of the Supply Application is to improve the supply ordering and parts tracking process. Users may submit on-line Purchase Requests (PRs), follow up on the status of their orders, and view a past order archive with this application.

The Supply Application radically redefines work roles by pushing responsibility for Purchase Request status updates back down to the individual who submitted the order. This design addresses one of the Commands top goals, to liberate the Storekeeper of the tedious and mundane task of checking up on everyone else's PRs.

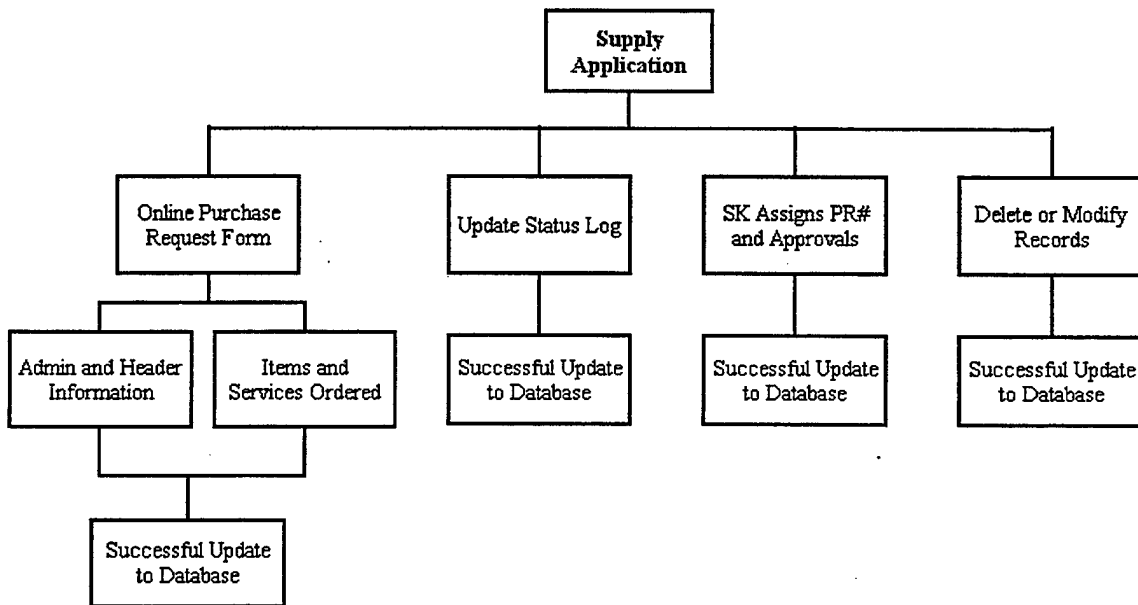

Figure 8.40 Supply Application Navigation Structure

2. Web Pages of the Supply Application

a. **List of Web Page Figures:** The following table lists the names of the Web pages of this application and the corresponding figure numbers.

Web Page	Figure
Supply Database Home Page	8.42
On-line Purchase Request Form – Part 1	8.43
On-line Purchase Request Form – Part 2	8.44
Complete Purchase Request	8.45
Warning Box about Assigning PR Numbers	8.46
Storekeeper Form to Assign PR Number	8.47
Status Log Update Form	8.48
Order Marked as Received	8.49

Figure 8.41 Table of Web Pages and Corresponding Figures

Electronic Support Unit Alameda Intranet

Supply Web Database Application

[Click here to fill out a New Purchase Request](#)

[Past Purchase Request Archive](#)

Storekeeper's To Do List: Outstanding PR's without assigned PR numbers

Date PR Submitted	Department/Branch	Name of Person to Contact	Assign PR number etc.
5/4/98	COTR Branch	ETC Chuck McClain (562) 732-7271; Location: ESU Det San Pedro	details Assign PR #

[Back to Top](#)

Crewmember's To Do List: Outstanding orders are listed by department. Individuals who submit PRs are required to periodically review their order(s) here and update the status by following link to the PR status log.

[Electronic Systems Branch](#) [IRM Branch](#) [COTR Branch](#) [ESU Business Services Branch](#) [Detachment Ozark](#) [Contracted Source](#) [Other](#) [Detachment San Pedro](#) [Detachment San Diego](#)

Electronic Systems Branch

Name of Person to Contact	Purchase Request Number	Date of Last Status Update	Click for Details	Received or Delete
LT Todd Harnah () 1234567; Location:	123123	5/4/98	* PR details * View Status Log * Update Status Log	* Order Received * Delete PR

[Back to Top](#)

IRM Branch

Name of Person to Contact	Purchase Request Number	Date of Last Status Update	Click for Details	Received or Delete
GS7 Brenda Rios (510) 437-5784; Location: ESU Alameda	1231234	4/7/98	* PR details * View Status Log * Update Status Log	* Order Received * Delete PR

Figure 8.42 Supply Database Home Page

b. Supply Database Home Page: The Supply Database Home Page presents the user with a list of all outstanding Purchase Requests (PR) at the ESU. There is a "To Do" list for the Storekeeper which shows all PRs that have been submitted but have not yet been assigned a PR Number. The remainder of the page contains ESU personnel "To Do" lists, organized by department. Each person who has submitted a PR is required to periodically check on the status of the request, with the supply vendor, and update a status log. Previously, this information was not available to all employees and the Storekeeper had to individually check up on the status of each outstanding PR.

Electronic Support Unit Alameda Intranet

Step 1: Fill out the following initial data for the PR.

P	PROCUREMENT PROCESS	R	REQUEST APPLY
1. Name, Phone Number and Branch of Person to Contact			
Name: <input type="text" value="LT Todd Hannah () 1234567; Location:"/>			
Branch: <input type="text" value="Electronic Systems Branch"/>			
Location: <input type="text" value="ESU Alameda"/>			
2. Type of Request			
New Request <input checked="" type="radio"/>			
4. Additional Information (Suggested supply sources, etc.)			
Name: <input type="text" value="Joes Hardware"/>			
Address: <input type="text" value="Downtown"/>			
City: <input type="text" value="Monterey"/>		State: <input type="text" value="CA"/>	Zip: <input type="text" value="93940"/>
Phone: <input type="text" value="5555555"/>		ext: <input type="text"/>	Attention: <input type="text"/>
5. Approving Officials			
	Approving Officials (A)	Routing Symbol (B)	Date (C)
(1) Authorized Requisitioner Name			
Name: <input type="text" value="CDR Ed Lane"/>		<input type="text" value="XO"/>	
(2) Accounting Certification Officer			
Name: <input type="text" value="SKC Darwin Bennett"/>		<input type="text" value="Storekeeper"/>	
(3) Supervisor			
Name: <input type="text" value="LT Barney Fife"/>		<input type="text" value="Electronic Systems Branch"/>	
(4) Requester			
Name: <input type="text" value="LT Todd Hannah"/>		<input type="text" value="Electronic Systems Branch"/> 5/4/98	
6. Consignee and Destination			
Name: <input type="text" value="COMMANDING OFFICER, ESU ALAMEDA"/>			
Address: <input type="text" value="BLDG 21 RM128 COAST GUARD ISLAND"/>			
City: <input type="text" value="ALAMEDA"/>			
State: <input type="text" value="CA"/>		Zip: <input type="text" value="90000"/>	
Priority: <input type="text"/>			
7. Date Required <input type="text"/>		Unit/Unit Providing LUMS Support (Program Element Code) <input type="text" value="ESU Alameda/MLCP(T)"/>	
8. Government Furnished <input type="radio"/> Yes <input checked="" type="radio"/> No		Unit/OPFAC this PR Supports (Cost Center) <input type="text"/>	
Submit Initial Data - Start a New Purchase Request Form			

Figure 8.43 On-line Purchase Request – Part 1

c. On-line Purchase Request – Part 1: This is the first half of a Purchase Request Form. It contains all the same fields, organized the same way, as a traditional paper PR form.

Electronic Support Unit Alameda Intranet

Part 2: Fill out the Description of Items or Services you wish to purchase.

P ROQUIREMENT ROCESS **R** EQUEST RAPIDLY

9. Description of Items or Services

Item No	Item or Service <small>(Please DO NOT press return in this input box. Use a single, continuous sentence - everything after a return will not get entered.)</small>	QTY	Unit	Unit Cost
1	Hammers	15	EA	6.00
2	Nails	15	DZ	5.00
3			EA	
4			EA	
5			EA	

Figure 8.44 On-line Purchase Request – Part 2

d. On-line Purchase Request – Part 2: This is the second half of a Purchase Request Form. It contains all fields for ordering up to five items. If the user wants to order more than five, they can press the "Order More" button and fill out another five items.

Electronic Support Unit Alameda Intranet

The following Purchase Request has been submitted and is now pending For Action:

PROUREMENT **R**EQUEST
PROCESS RAPIDLY

Purchase Request Number

1. Person to contact:	LT Todd Hannah () 1234567; Location:
2. Type of Request:	New Request
3. Orig Office Branch & Location	Electronic Systems Branch;
4. Suggested Source of Supply	Joese Hardware Downtown Monterey, CA 93940: 5555555 ext. Attn:
5. Approving Officials	
Authorized Requisitioner	CDR Ed Lane, XO
Accounting Certification Officer:	SKC Darwin Bennett, Storekeeper
Supervisor:	LT Barney Fife, Electronic Systems Branch
Requester:	LT Todd Hannah,
6. Consignee and Destination:	COMMANDING OFFICER, ESU ALAMEDA BLDG 21 RM128 COAST GUARD ISLAND ALAMEDA, CA
7. Date Required	
8. Government Furnished:	No
Unit/Unit Providing LUFS Support	30/0/5A
Unit/OPFAC this PR Supports	53700

Item Number	Description of Items or Services	Qty	Unit	Unit Cost	
1	Hammers	15	EA	6	edit
2	Nails	15	DZ	5	edit

[Edit Admin Data \(1-8\)](#)

[Add New Item \(9\)](#)

[Go to Supply Home](#)

Mark Order as Received

[Fill out Another Purchase Request](#)

[Supply Database Status Page](#)

[Past PR Archive](#)

[View Status Log History](#)

Figure 8.45 Complete Purchase Request

e. Complete Purchase Request: This is the page the viewer sees when the final PR order has been completed and has been submitted to the database.

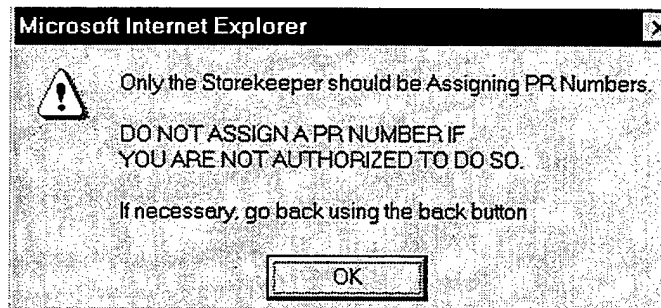

Figure 8.46 Warning About Assigning PR Numbers

Electronic Support Unit Alameda Intranet

The following PR will be assigned a PR Number

Assigne PR Number here:

1. Person to contact:	LT Todd Hannah () 1234567; Location:
2. Type of Request:	New Request
3. Orig Office Branch & Location	;
4. Suggested Source of Supply	Joese Hardware Downtown Monterey, CA 93940: 5555555 ext. Attn:
5. Approving Officials	

Figure 8.47 Storekeeper Form to Assign PR Number

f. Storekeeper Form to Assign PR Number: The Storekeeper can use this form to assign a PR number to a submitted request once the funding and other administrative tasks have been completed. The warning box alerts users that only the Storekeeper is authorized to assign PR numbers.

Electronic Support Unit Alameda Intranet

Status Log Updates

Status Log Update: Updates this PR

Update Text:	<input type="text" value="Joe's Hardware is still out of hammers."/>
Updated By:	<input type="text" value="Hannah, Todd (LT)"/>
Date of Update:	<input type="text" value="5/4/98"/>
<input type="button" value="Submit Update"/> <input type="button" value="Reset"/>	

or

[Mark Order as Received](#)

Status Log Update History: History of Status Log updates for this PR

Date of Update	Updated by:	Update Text:
	PR #	
	Date Submitted	5/4/98
	Point of Contact	LT Todd Hannah () 1234567; Location:

[View Status Log History](#)

[Supply Database Status Page](#)

[Past PR Archive](#)

[Fill out new Purchase Request](#)

Figure 8.48 Status Log Update Form

g. Status Log Update: The user may use this form to update the database status log. On the Intranet, this becomes an individual responsibility. Before the Intranet solution, the Storekeeper had to maintain the status updates of all PRs because all the PR forms were kept in a paper file folder. By distributing the PR status information across the Intranet, the unreasonable burden of tracking everyone's PRs is distributed from the Storekeeper to the entire organization. This was one of the Commands top goals.

Electronic Support Unit Alameda Intranet

The following PR will be **MARKED AS RECEIVED**

Enter the Date the order was received (mm/dd/yy format): 5/5/98

Procurement Request Number: 123123

1. Person to contact:	LT Todd Hannah () 1234567; Location:
2. Type of Request:	New Request
3. Orig Office Branch & Location	;
4. Suggested Source of Supply	Joes Hardware Downtown Monterey, CA 93940: 5555555 ext. Attn:

Figure 8.49 Order Marked as Received

h. Order Marked as Received: This form is used so those individuals may mark off when a PR order process has been completed. This removes the PR from the outstanding PR "To Do" lists on the Supply Database Home Page. The information is recorded in the Past PR Archive page (not shown).

J. SECURITY APPLICATION

1. Introduction

The Security Application is present throughout all other applications on the Intranet. Security is handled on a page by page basis as explained in detail in Chapter VII. This section provides screen shots of successful and unsuccessful logins.

2. Web Pages of the Security Application

a. List of Web Page Figures: The following table lists the names of the Web pages of this application and the corresponding figure numbers.

Web Page	Figure
Home Page with Security Application Login Highlighted	8.51
Successful Login	8.52
Unsuccessful Login	8.53
Access Denied	8.54

Figure 8.50 Table of Web Pages and Corresponding Figures

Electronic Support Unit Alameda Intranet

Welcome to the ESU Alameda Intranet Site! As a guest user you may browse any pages found under the "Extranet" banner in the navigation bar. All information is For Official Use Only.
 (Please note that you are not currently logged in as a validated ESU Alameda Intranet user and you will not have access to internal ESU pages.)

<h3>General Announcements</h3> <table border="1" style="width: 100%; border-collapse: collapse;"> <thead> <tr> <th style="width: 60%;">Announcement</th> <th style="width: 40%;">Posted by</th> </tr> </thead> <tbody> <tr> <td style="text-align: center;">Post a New Announcement</td> <td></td> </tr> </tbody> </table>	Announcement	Posted by	Post a New Announcement		<h3>Personnel on Leave Today</h3> <table border="1" style="width: 100%; border-collapse: collapse;"> <thead> <tr> <th style="width: 60%;">Name</th> <th style="width: 40%;">Leave Period ends on:</th> </tr> </thead> <tbody> <tr> <td>Doolittle, Doctor (LT)</td> <td>5/15/98 after 15 days.</td> </tr> </tbody> </table> <p style="text-align: center;">Leave Summary</p> <h3>Personnel TAD Today</h3> <table border="1" style="width: 100%; border-collapse: collapse;"> <thead> <tr> <th style="width: 50%;">Name</th> <th style="width: 25%;">TAD until</th> <th style="width: 25%;">Where</th> </tr> </thead> <tbody> <tr> <td></td> <td></td> <td></td> </tr> </tbody> </table> <p style="text-align: center;">TAD Summary</p>	Name	Leave Period ends on:	Doolittle, Doctor (LT)	5/15/98 after 15 days.	Name	TAD until	Where			
Announcement	Posted by														
Post a New Announcement															
Name	Leave Period ends on:														
Doolittle, Doctor (LT)	5/15/98 after 15 days.														
Name	TAD until	Where													

Security

Intranet Login

Allows for access to pages intended for ESU members only. You MUST login to have access to databases.

Username:

Password:

Figure 8.51 Home Page with Security Application Highlighted

b. Home Page with Security Application highlighted: This is the page the user logs into the Intranet from.

Electronic Support Unit Alameda Intranet

Your Login Succeeded!

You are logged in as: admin
Security Session Access Level: admin

Please [return to the ESU Home page](#) to begin.

Figure 8.52 Successful Login

Your Login Failed

Please [return to the ESU Home page](#) to login again or access areas that require no security privileges.

Figure 8.53 Unsuccessful Login

Electronic Support Unit Alameda Intranet

You are logged in as
Security Session Access Level

You do not have access to that web page. The page you have requested requires for you to log in at a Security Session Access Level higher than .



[LOGIN: Click here](#) to return to the ESU Welcome page where you may Login.

Figure 8.54 Access Denied

c. **Security Login Pages:** The top two pages are displayed for either a successful or an unsuccessful login attempt. The Access Denied page is displayed when a user requests a page that is restricted to a security access level which is higher than what the user is logged in at.

K. CONCLUSION

It is difficult to capture the way a software system works by presenting it on paper. There are over 80 Web pages on the Intranet and, of course, not all of them were presented in this chapter. This section attempted to describe the basic feel and functionality of the Intranet with selected screen shots from its applications.

IX. IMPLEMENTATION

A. INTRODUCTION

The Intranet will be installed at the ESU about six months after the project's initiation. From a technical standpoint, the physical installation is straightforward. The implementation process, however, is far more than just the physical installation of software. It involves complex management issues of organizational change leveraged through information technology. The final outcome of the implementation process, and its impact on the organization, will not be fully understood for quite some time.

The goal of this project is a successful implementation of a new Intranet that adds value to the ESU. The minimum definition of success is an implementation resulting in a prototype. This basic prototype could then serve as a foundation for future independent development efforts. If the implementation is more successful, the Intranet could become an operational, working product that would be used daily and maintained, and improved locally.

The Intranet is a powerful, technically sound, well-designed and fully functional tool that has the potential to add significant value to the ESU Command. The fact that the Intranet is a high quality product, however, does not guarantee its acceptance or use throughout the organization.

Implementation is an organizational wide process of change that will alter current lines of communication and business practices. This change has both social and technical aspects (Lawrence, 197). The development of the product, up to this point, has focused

on the technical aspects of analysis and physical design. It is, however, the social aspect of the change that determines the final result.

The implementation process includes both the Implementation and Maintenance Phases of the Waterfall Model. This section focuses on the management and change issues that are involved, and a formula for change is introduced. The change formula is a tool for assessing organizational readiness and a plan of action for change.

B. IMPLEMENTATION

The Implementation and Maintenance Phases of the Waterfall Model include steps such as installing the new software, preparing the training plan, and establishing the long-term maintenance schedule for the new system. These are the technical steps that must be taken for any successful system's implementation.

The technical steps are essential to a successful implementation, but the social considerations are what determine the final outcome. Introducing an information system, which radically alters the way people communicate, will have social consequences for the entire organization. These consequences, and different ways of seeing and managing them, should be considered.

There is a wide spectrum of possible organizational responses to the new tool. At one end of the spectrum, the Intranet could be resisted, completely ignored, and never used after the first install day. At the other end, it could be adopted wholeheartedly and the ESU could take complete ownership for the system. ESU ownership means they would use it daily, maintain it locally, and improve it constantly. There are many reasons why the implementation outcome might be somewhere in the middle. Even if the Intranet

is simply recognized as a “vision of future possibilities”, the goal of this thesis will have been met.

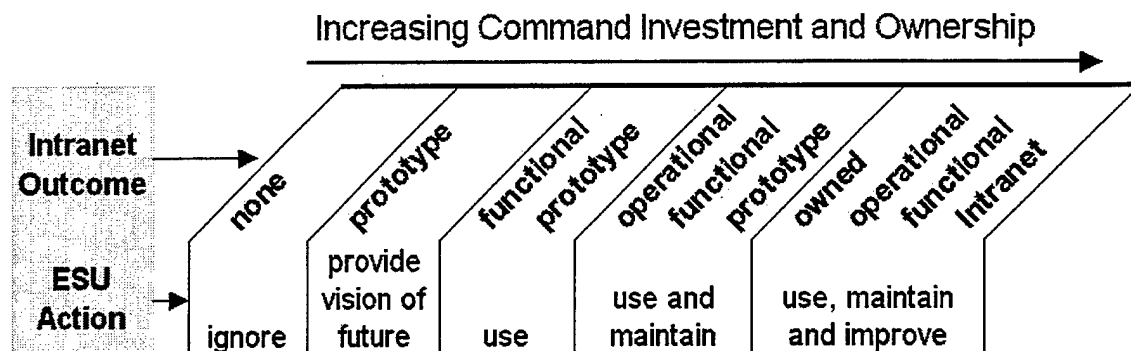

Figure 9.1 Spectrum of Possible Implementation Outcomes

Figure 9.1 illustrates the possible spectrum of Intranet implementation outcomes and the corresponding organizational reactions to them. In the figure, “functional” means some employees use the system. “Operational” means the system is relied upon as a tool for the ESU’s daily business. “Owned” indicates a Command investment of resources for both maintenance and improvement of the new systems. The spectrum of success increases from left to right with a corresponding increase of Command investment and ownership.

In all possible outcomes, the Intranet can serve as one prototype in the Rapid Prototyping model of systems development. Rapid Prototyping, as explained in Chapter IV, is an iterative process of development. The left end of the spectrum in Figure 9.1 corresponds to the early prototypes of the Rapid Prototyping iterative development model (see Figure 4.3). The increasing Command investment and ownership of the system found towards the right end of the spectrum correspond to more mature prototypes which the Command itself could test, revise and enhance to their own requirements.

There are many possible reasons why the implementation process might not be successful. If old business processes still occur, in parallel with the new Intranet methods, confusion could arise. If the new technology is misused by employees who perform unauthorized deletions of records or mistaken submission of on-line forms, the Command could conclude that the costs of doing business a new way outweigh benefits of the old. Resistance to change, a poor maintenance plan, no backup policy, no training plan, or no commitment to improving the Intranet are all possible reasons that could also lead to a failed implementation.

The solution to these potential problems is to consider the Intranet implementation from a systems thinking perspective. The new Intranet must be considered as a dynamic, living entity that must have attention. The databases require current, accurate data in order to be relevant. The phone book application database, for example, must be populated with accurate phone numbers. The Intranet can not be installed and be expected to maintain itself. A complete management plan, including decisions on who will own the Intranet, who will maintain it, who will enter data, and who will use it, must be considered. The new Intranet policy should, at a minimum, address security issues, acceptable use instructions, and a backup plan.

C. STRATEGIES FOR CHANGE

1. Introduction

A general strategy for introducing change into an organization includes three basic stages. First, the organization must be “unfrozen”. This is when the organization

prepares for a change. The leadership should foster an environment that is dissatisfied with the status quo. The middle stage is the transition period when the change actually occurs. An ideal vision of the future state, after the change has been implemented, should be articulated by the change advocates. The final stage is when the change has been completed. During this stage, the organization should support and maintain the change.

The General Accounting Office (GAO) Executive Guide on Improving Mission Performance Through Strategic Information Management and Technology describes three key processes that the GAO considers critical to introducing an Information Technology change to an organization. They are: "(1) *deciding* to work differently... (2) *directing* resources ... and (3) *supporting*" (GAO Report, 7). These three processes parallel the three stages of unfreezing, transitioning, and supporting change.

The following section introduces a change formula that is useful for assessing the first two stages of introducing change, unfreezing and transitioning. The next section introduces the concept of a systems loop. The systems loop describes the possible outcome of a change after it has been implemented and is in the third and final stage of maintenance and support.

2. Change Formula

a. Definition: One way of introducing change is to consider it in the context of a formula for change. The change formula, adapted from Professor Michael Beer's article "Leading Change" (p.3, Beer, 1988), can be used to assess organizational readiness for change and to implement the change. The change formula, and its relevance to the ESU Intranet implementation, is presented below.

$$\text{successful change} = \frac{\text{"dissatisfaction with present"} \times \text{"ideal vision of future"} \times \text{"process of change"}}{\text{"cost of change"}}$$

The formula states that there are three critical factors that must be considered for a successful change. These factors are multiplied, meaning if one is missing then the whole formula is equal to zero, and the change will fail. All three factors must be present with sufficient strength to be greater than the cost of change (p.3, Beer, 1988).

b. Successful Change: Implementation of the Intranet would be a successful change for the ESU. The Intranet would add value to the ESU by allowing them to do current business processes in a new, more efficient and effective, way. The change could be considered increasingly successful as one moves farther to the left on the scale presented in Figure 9.1.

c. Dissatisfaction with Present: Dissatisfaction with the status quo is critical because it provides the energy for overcoming organizational resistance to change (p.4, Beer, 1988). An advocate of change must be someone who is unsatisfied with the current way of doing business and believes that there is a better way. During the requirements capture phase of the project, the Command at ESU indicated that there were in fact some processes that they would like to see improved. Each of these goals are technically addressed with functioning Intranet applications. The Intranet was developed to specifically address these problems and issues.

From a top down perspective, the Command must become the advocate of change. The Command can create an environment that is ready for it by insisting on using the Intranet applications. Urging employees to do business in a new way will indicate to the

rest of the organization that the Command is not satisfied with the status quo. This will create an environment that is ready for change. Command advocacy of the Intranet will send the signal that is good to use the Intranet.

If the Command is content with old business processes, in spite of the availability of new Intranet solutions, then they are effectively satisfied with the status quo. If the Command doesn't create the environment for change through advocacy, then the rest of the organization will not have the incentives to change.

An environment of dissatisfaction with the status quo can also be fostered from the bottom up. If the employees of the organization find that the Intranet is a technically sound solution that has potential to add value to their work, then they are likely to use it. The more key personnel who share this idea that the Intranet is useful, or has the potential to be of use, the more likely the environment for change will be ready.

d. Ideal Vision of the Future: Many personnel at ESU must share the "vision of what is possible" with a new Intranet. They must recognize it as an improvement over the status quo. A sufficient number of key stakeholders must understand how new Intranet applications will add value to their daily work. The ESU Command can do this by ensuring all personnel have seen the system and are trained in how to use it.

e. Progress of the Change: The change to using the Intranet will not occur overnight. Simply dropping the Intranet into the ESU will not mean it will be adopted immediately. The idea must be sold to the employees of the organization who will judge the new tool over time.

The training and demonstration sessions can be used to showcase the merits of the system and to gather feedback on ways it can be improved. The Command could appoint

various personnel, who are proficient in HTML code, to improve aspects of the system. People will become committed to a project that they help create (p.5, Beer, 1988).

Initially, the physical installation of the Intranet is critical to get right. The first few days of its deployment is a crucial time when most people will form strong opinions about whether or not it adds value to the ESU. Before it is presented for ESU use, the Intranet should be running normally, error-free, on the Web server. If the system is slow and inefficient, plagued with frequent crashes or bugs, is difficult to use or has other problems that makes its use unpleasant, then it is unlikely people will make any effort to fix it.

f. Cost of Change: Every change has consequences. Although the physical cost of building the Intranet was almost nothing, the long-term cost of implementation is more significant. The ESU will have to invest resources into the maintenance of the system. Someone will have to spend time writing policy on Intranet use, validating the accuracy of the databases, and ensuring the Web server is running. Training costs will be incurred in order to ensure someone at the Command has a proficiency in administering the Web server, authoring Web page code, and possibly even learning how to use Active Server Pages.

The social cost of implementing an Intranet should also be considered. The Intranet opens a new avenue of communication across the organization. This new means of communication could, for example, have consequences for job roles and positions of power.

g: Conclusion: All of the criteria of the change formula must be present for an environment for change to exist. These factors must cumulatively outweigh the cost of the change in order for it to have a reasonable chance of actually occurring.

3. Systems Loops

The third and final stage of introducing a change is the support and maintenance phase after the change has occurred. It is anticipated that the introduction of the Intranet will be met with initial enthusiasm and excitement at the ESU. Since it is a technically sound product, the Command is likely to realize the potential the new system has to add value to the organization. The excitement is likely to generate Command and organizational investment in the product, which will in turn lead to growth and use of the Intranet. Initially, the implementation is likely to be a success.

At some point, however, the growth experienced at the beginning will slow. If the Command has not heeded the advice about preparing the environment for change presented above, then the limits to growth will quickly appear. The slowdown could become so significant that eventually everyone stops using the system, marking the end of the value it can add to the ESU's daily operations.

This process of growth and then slowing will almost certainly happen at some point during the implementation process. The only question is if it will happen sooner rather than later. The key principle for the Command to consider is that removing the factors that limit growth will delay the eventual slowing.

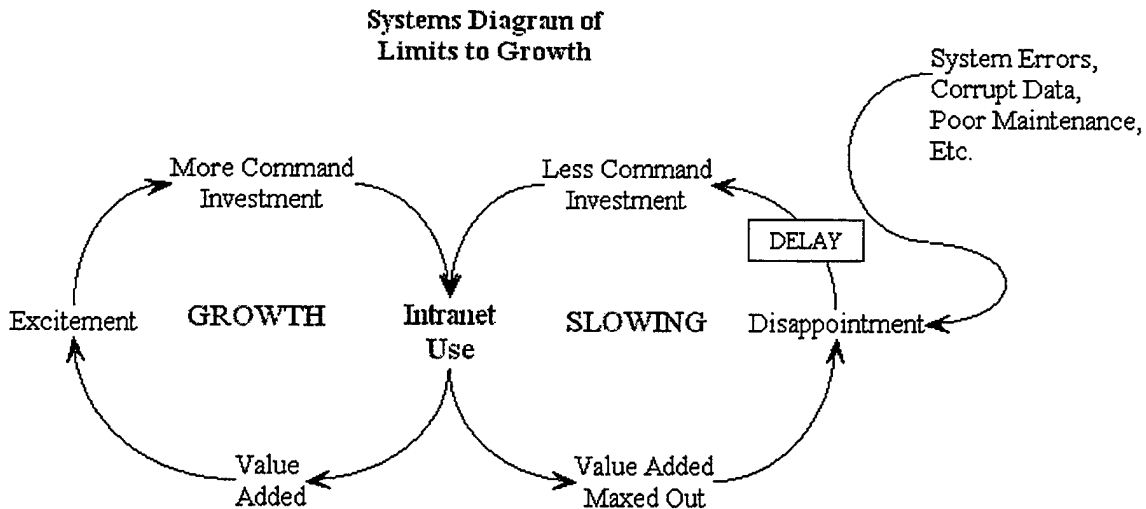

Figure 9.2 Limits to Growth System Loop of Intranet Implementation

This diagram of considering systems as loops of growth and slowing is adapted from Peter Senge's "Limits to Growth" system loop archetype (p.73, Senge, 1990). It is presented in the context of an ESU Intranet implementation. The limiting factor is represented as a poor maintenance plan, which could lead to system errors, corrupt data, or security violations. The consequences of the limiting factor reveal themselves after a period of delay.

D. PHYSICAL INSTALLATION

The technical aspects of a physical installation are straightforward. The general steps were outlined in Chapter VII. On-line documentation regarding setup and installation of these commercially available products is extensive.

The Intranet software requirements must exactly match between the NPS machine the Intranet was developed on and the ESU Web server the Intranet will actually be deployed on. The ESU had to prepare their Web server with the latest software versions

used for the project development. Some upgrades were necessary to host the site. The physical installation will occur over the summer of 1998.

E. CONCLUSION

There is little doubt that the Intranet is a quality product that can add significant value to the organization. Technically, it operates reliably, without errors, and has a clean, easy to use design. Unfortunately, successful integration of the Intranet into the ESU will not depend on its technical merits. It is the social aspect of the change that will determine the final outcome of the implementation process. It may take up to a year to accurately judge the final effects of introducing Intranet technologies into the ESU Alameda workplace.

X. CONCLUSION

The development effort resulted in a functional, operational Intranet for a USCG unit. Commercial development of such a system would cost well into the thousands of dollars.

This prototype for this Intranet is generic enough to be adaptable to almost any USCG setting. It provides solutions to business processes that are common at almost all USCG units. Applications for up to date phone listings, recall logs, leave requests, temporary duty requests, marks schedules, and unit-wide announcements would probably be desirable to have at any USCG unit.

Whether the implementation process for this Intranet leads to an operational tool that is used daily, or if the implementation leads to a simple prototype, this thesis has been a success. A simple idea has grown into a reality. By following an information systems software design methodology, a working product has been developed. Along the way the author has acquired technical skills in software development, business analysis skills for information systems requirements analysis, and managerial skills for implementing an information systems change into an organization.

APPENDIX A. ASP APPLICATION - DESIGN AND CODE

A. INTRODUCTION

The Announcements Application on-line form is used as example here to illustrate the development of an Active Server Pages Web page. An ASP page, ending in the ".asp" extension, consists of both HTML code and Visual Basic Script. The HTML code is mostly accomplished with a visual Web page development tool, Front Page 98 Editor in this case. The VB Script had to be written into the page line by line, without the assistance of any visual development environment. The VB Script code is shown in Figures A.2 through A.4 as comments on the FP98 Editor page. (The real code is inside the dark boxes.)

There are over 80 Web pages on the ESU Intranet. Most of them are Active Server Pages. The code for each page takes up roughly five to ten typewritten pages of HTML and VB Script. Listing hundreds of pages of code here is impractical, so what follows is a look at the code, for just one page, through the visual development environment of Front Page 98.

This ASP page is named "announcements_form.asp". It is an on-line form that requests user input and then updates the Announcements database with it. The form is spread across three figures because it would not fit on just one page. The basic concepts of using ASP to perform these operations are briefly explained. These operations are similar throughout all the pages of the Intranet. The 5 pages of HTML and ASP code that are behind this visual development are also included.

B. FRONT PAGE 98 VISUAL DEVELOPMENT ENVIRONMENT OF ANNOUNCEMENTS_FORM.ASP

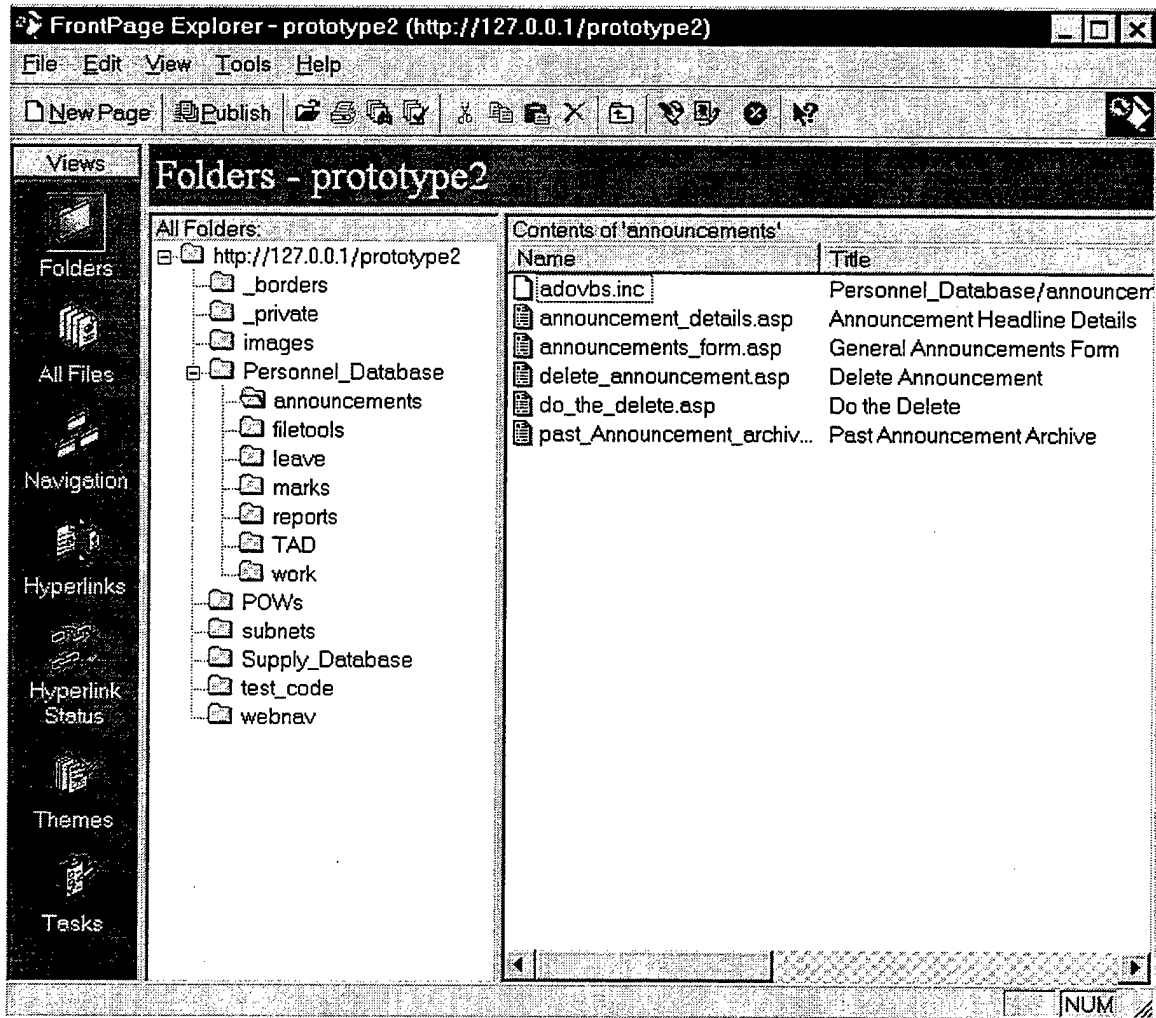

Figure A.1 View of Intranet in Front Page 98 Explorer

The entire ESU Alameda Intranet is shown here in the FP98 Explorer window.

The Announcements Application folder is open.

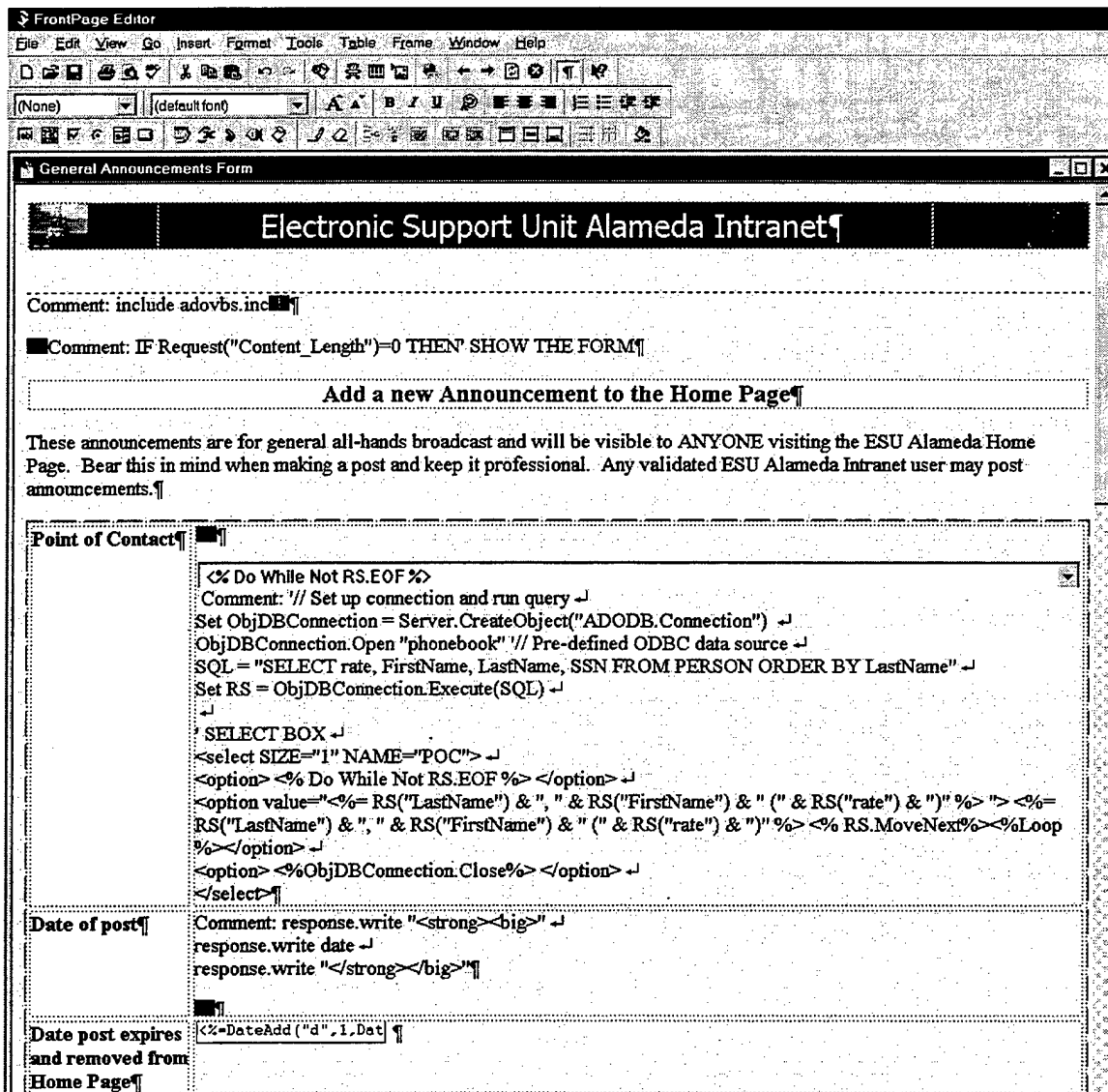

Figure A.2 Announcements Form in FP98 Editor (Part 1)

The first part of the form is shown here. Using an IF-THEN LOOP, the page checks to see if the form has been filled out yet. If it has not, then it displays the announcement form.

Announcement Headline for Home Page: ↵ (Please limit to one or two lines without carriage returns.) ↵	<input type="text"/>
Details of Announcement: ↵ (Only headline visible on Home Page. Details upon following hyperlink. No carriage returns.) ↵	<input type="text"/>
<input type="submit" value="Post Announcement to ESU Alameda Home Page"/>	

```

■ Comment: ELSE ' Do the update' ↵

■ Comment: '// Set up connection and run query ↵
Set Conn = Server.CreateObject("ADODB.Connection") ↵
Conn.Open "announcements" '// Pre-defined ODBC data source ↵
↵
SQL = "SELECT * FROM Announcements" ↵
↵
set rs = server.CreateObject("ADODB.Recordset") ↵
↵
' // unlock recordset RS ↵
RS.LockType = adLockOptimistic ↵
↵
' // create and open a new RS ↵
RS.open SQL, Conn, adOpenKeySet ' openkeyset to navigate and reuse this recordset ↵
↵
' //update the recordset ↵
'// note the use of AddNew as ALL requests will be new ↵
↵
poc = request.form("poc") ↵
begin_date = date() ↵
end_date = request.form("end_date") ↵
announcement = request.form("announcement") ↵
details = request.form("details") ↵

```

Figure A.3 Announcements Form in FP98 Editor (Part 2)

This is the second part of the form. When the user completes the form and presses the submit button, the form is submitted back to itself on this same page. The IF-THEN LOOP will detect that data has been submitted and the page will begin processing after the ELSE ' DO THE UPDATE statement shown above.

This form is a typical ASP Web page that collects information from the user, inserts the data into an ODBC database, and displays the results. The code used on this page is re-usable in the sense that the same general method is used throughout the ESU Intranet.

```

RS.AddNew ↵
RS("poc") = poc ↵
RS("begin_date") = begin_date ↵
RS("end_date") = end_date ↵
RS("announcement") = announcement ↵
RS("details") = details ↵
'//UPDATE it ↵
RS.update ↵
↵
' Close connection ↵
Conn.close¶

```

Success. ↵

Your announcement has been posted to the ESU Alameda home page as follows:¶

Headline:¶	<input type="text"/> ¶ <small>Comment: response.write("<BIG>") ↵ response.write announcement ↵ response.write("</BIG>")¶</small>
Details:¶	<input type="text"/> ¶ <small>Comment: =details¶</small>
Posted on:¶	<input type="text"/> ¶ <small>Comment: =begin_date¶</small>
Post expires:¶	<input type="text"/> ¶ <small>Comment: =end_date¶</small>
Point of Contact: ¶	<input type="text"/> ¶ <small>Comment: =poc¶</small>

■Comment: END IF ¶

Figure A.4 Announcements Form in FP98 Editor (Part 3)

The ASP pseudocode for the update is presented below (see Figures A.3 and A.4):

- a Connection object named "Conn" is created with the ODBC datasource "Announcements"
- a variable named SQL is assigned as an SQL statement
- a RecordSet object named "rs" is created
- the open method is used on the object "rs" which runs the SQL
- a new RecordSet is created
- the RecordSet is populated with the values from the users form
- the RecordSet is updated
- the connection is closed

C. HTML CODE OF ANNOUNCEMENTS_FORM.ASP

The HTML code that is behind the visual development environment of Front Page 98 is presented below. The Visual Basic Script, used for making the Web page an Active Server Page, is highlighted in bold typeface.

```
<%
' *****
' * PERSONNEL DATABASE - Announcements
' *
' * For every page that you want to enable access control, put the
include
' * file and this file in the same directory.
' * Type <!--#include file="../LoginCheck.inc" -->
' * BEFORE the <html> tag (very important) at the top of the page you
' * want to control access to. Also include the following script.
' *
' * If session("security") = "Guest" then
response.redirect("../no_access.asp")
' * end if
' *
' *****
%>
<!--#include file="../user_access.inc"-->
<%
If session("security") = "Guest" then
response.redirect("http://cg.nps.navy.mil/prototype/no_access.asp")
end if
%>
<html>

<head>
<meta name="GENERATOR" content="Microsoft FrontPage 3.0">
<title>General Announcements Form</title>

<meta name="Microsoft Border" content="t, default"></head>

<body stylesrc="http://127.0.0.1/prototype2/_private/style.htm"
background="../../images/Fleck.gif" vlink="#0000FF"><!--msnavigation--
><table border="0" cellpadding="0" cellspacing="0" width="100%"><tr><td>

<table border="0" width="100%" cellspacing="0" cellpadding="0"
height="45">
  <tr>
    <td width="121" bgcolor="#000040" height="11" valign="top"></td>
    <td width="730" bgcolor="#000040" height="11" valign="middle"><p
align="center"><big><font color="#FFFFFF" face="Tahoma"><big>Electronic
Support Unit Alameda Intranet</big></font></big></td>
    <td width="148" bgcolor="#000040" height="11" valign="top"><p
align="right"></td>
  </tr>
</table>
</td>
</tr>
</table>
</body>
</html>
```

```

</table>
</td></tr><!--msnavigation--></table><!--msnavigation--><table
border="0" cellpadding="0" cellspacing="0" width="100%"><tr><!--
msnavigation--><td valign="top">

<p><!--webbot bot="PurpleText" preview="include adovbs.inc" --><!--
#include file="adovbs.inc" --></p>

<p><%IF Request("Content_Length")=0 THEN' SHOW THE FORM%><!--webbot
bot="PurpleText" PREVIEW="IF Request(&quot;Content_Length&quot;)=0 THEN'
SHOW THE FORM" --></p>

<table border="0" width="100%">
  <tr>
    <td width="100%" bgcolor="#FFFF80"><p
align="center"><strong><big>Add a new Announcement
to the Home Page</big></strong></td>
  </tr>
</table>

<p>These announcements are for general all-hands broadcast and will be
visible to ANYONE
visiting the ESU Alameda Home Page.&nbsp;&nbsp;&nbsp;Bear this in mind when making
a post and keep it
professional.&nbsp;&nbsp;&nbsp;Any validated ESU Alameda Intranet user may post
announcements.</p>

<form ACTION="announcements form.asp" METHOD="POST" onsubmit="return
FrontPage_Form1_Validator(this)" name="FrontPage_Form1">
  <table border="0" width="100%" cellspacing="4" cellpadding="0">
    <tr>
      <td width="35%" valign="top" bgcolor="#E8E8E8"><font
color="#000000"><strong>Point of
Contact</strong></font></td>
      <td width="50%" valign="top">
<%// Set up connection and run query
Set ObjDBConnection = Server.CreateObject("ADODB.Connection")
ObjDBConnection.Open "phonebook" '/// Pre-defined ODBC data source
SQL = "SELECT rate, FirstName, LastName, SSN FROM PERSON ORDER BY
LastName"
Set RS = ObjDBConnection.Execute(SQL)%>
<p><!--webbot bot="Validation" B-Value-Required="TRUE" B-Disallow-First-
Item="TRUE" --><select SIZE="1" NAME="POC">
  <option> <% Do While Not RS.EOF %> </option>
  <option value="<%= RS("LastName") & ", " & RS("FirstName") & "
(" & RS("rate") & ")" %> "> <%= RS("LastName") & ", " & RS("FirstName")
& " (" & RS("rate") & ")" %> <% RS.MoveNext%><%Loop %></option>
  <option> <%ObjDBConnection.Close%> </option>
</select> </td>
    </tr>
    <tr>
      <td width="35%" valign="top" bgcolor="#E8E8E8"><strong><font
color="#000000">Date of post</font></strong></td>
      <td width="50%" valign="top"><%response.write "<strong><big>"
response.write date
response.write "</strong></big>"%>
    </td>
  </tr>
  <tr>

```

```

        <td width="35%" valign="top" bgcolor="#E8E8E8"><font
color="#000000"><strong>Date post
        expires and removed from Home Page</strong></font></td>
        <td width="50%" valign="top"><input TYPE="text"
VALUE="<%=DateAdd("d",1,Date)%>" SIZE="20" NAME="end_date"> </td>
    </tr>
    <tr>
        <td width="35%" valign="top" bgcolor="#E8E8E8"><font
color="#000000"><strong>Announcement
        Headline for Home Page: <br>
        </strong><small>(Please limit to one or two lines without carriage
returns.)</small></font></td>
        <td width="50%" valign="top"><textarea ROWS="2" COLS="40"
NAME="announcement">
</textarea></td>
    </tr>
    <tr>
        <td width="35%" valign="top" bgcolor="#E8E8E8"><font
color="#000000"><strong>Details of
        Announcement:<br>
        </strong><small>(Only headline visible on Home Page. Details upon
following hyperlink. No
        carriage returns.)</small></font></td>
        <td width="50%" valign="top"><textarea ROWS="4" COLS="40"
NAME="details">
</textarea></td>
    </tr>
</table>
    <div align="center"><center><p><input TYPE="submit" VALUE="Post
Announcement to ESU Alameda Home Page" NAME="post"> </p>
    </center></div>
</form>

```

```

<p><%ELSE ' Do the update%><!--webbot bot="PurpleText" PREVIEW="ELSE '
Do the update" --></p>

```

```

<p>
<%'// Set up connection and run query
Set Conn = Server.CreateObject("ADODB.Connection")
Conn.Open "announcements" ' // Pre-defined ODBC data source

SQL = "SELECT * FROM Announcements"

set rs = server.CreateObject("ADODB.Recordset")

' // unlock recordset RS
RS.LockType = adLockOptimistic

' // create and open a new RS
RS.open SQL, Conn, adOpenKeySet ' openkeyset to navigate and reuse this
recordset

' //update the recordset
' // note the use of AddNew as ALL requests will be new

poc = request.form("poc")
begin_date = date()
end_date = request.form("end_date")
announcement = request.form("announcement")
details = request.form("details")

```

```

RS.AddNew
RS("poc") = poc
RS("begin_date") = begin_date
RS("end_date") = end_date
RS("announcement") = announcement
RS("details") = details
' //UPDATE it
RS.update

' Close connection
Conn.close%>
</p>

<table border="0" width="100%">
  <tr>
    <td width="100%" bgcolor="#FFFF80"><p
align="center"><big><strong><big><big>Success.</big></big></strong></big>
<br>
    Your announcement has been posted to the ESU Alameda home page as
follows:</td>
  </tr>
</table>

<table border="0" width="558" cellspacing="4" cellpadding="0"
height="158">
  <tr>
    <td width="20%" valign="top" height="24">Headline:</td>
    <td width="80%" bgcolor="#E6FFE6" valign="top"
height="24"><%=response.write ("<STRONG><BIG>")
response.write announcement
response.write ("</STRONG></BIG>")%>
</td>
  </tr>
  <tr>
    <td width="20%" valign="top" height="21">Details:</td>
    <td width="80%" bgcolor="#FFFFFF" valign="top"
height="21"><%=details%>
</td>
  </tr>
  <tr>
    <td width="20%" valign="top" height="22">Posted on:</td>
    <td width="80%" bgcolor="#E6FFE6" valign="top"
height="22"><%=begin_date%>
</td>
  </tr>
  <tr>
    <td width="20%" valign="top" height="25">Post expires:</td>
    <td width="80%" bgcolor="#FFFFFF" valign="top" height="25"><%=
end_date%>
</td>
  </tr>
  <tr>
    <td width="20%" valign="top" height="46">Point of Contact: </td>
    <td width="80%" bgcolor="#E6FFE6" valign="top" height="46"><%=poc%>
</td>
  </tr>
</table>

<hr>

```

APPENDIX B. GLOSSARY OF TERMS

AOR (Area of Responsibility)

This is the term used to describe the geographic area where a USCG unit works,

BACK-END DATABASE

This term is used to describe the database that holds data used to generate pages on an Intranet.

BROWSER

A Client program (software) that is used to look at various kinds of Internet resources.

DFD (Data Flow Diagram)

A graphical display that illustrates business processes and data interfaces from a data perspective.

ESU (Electronic Systems Support Unit)

A U.S. Coast Guard facility that maintains and supports all facets of Coast Guard electronic equipment.

FTP (File Transfer Protocol)

A protocol used to transfer a complete file from one computer to another.

GUI (Graphical User Interface)

A GUI replaces the keyboard commands typical of old-fashioned computers with point-and-click buttons and menus.

HOME PAGE

The Web page that your browser is set to use when it starts up. The more common meaning refers to the main Web page for a business, organization, person or simply the main page out of a collection of Web pages

HTML (Hypertext Markup Language)

The coding language used to create Hypertext documents for use on the World Wide Web. HTML looks a lot like old-fashioned typesetting code, where you surround a block of text with codes that indicate how it should appear, additionally, in HTML you can specify that a block of text, or a word, is linked to another file on the Internet. HTML files are meant to be viewed using a World Wide Web Client Browser.

HTTP (Hypertext Transfer Protocol)

The protocol used to transport a WWW page from one computer to another.

HYPertext LINKS

Generally, any text that links to another document - words or phrases in the document that can be chosen by a reader and which cause another document to be retrieved and displayed.

INTERNET

The vast collection of inter-connected networks that all use the TCP/IP protocols and that evolved from the ARPANET of the late 60's and early 70's. The Internet now connects hundreds of thousands of independent networks into a vast global Internet.

INTRANET

A private network inside a company or organization that uses the same kinds of software that you would find on the public Internet, but that is only for internal use.

LAN (Local Area Network)

A network of computers that transmits data along a single shared medium in a small geographical area (i.e. a single office building or college campus).

LINK (See Hypertext LINK)

SK (Storekeeper)

An enlisted rating responsible for providing and accounting for the constant stream of supplies, clothing, commissary items and spare.

TAD (Temporary Assigned Duty)

The temporary assignment of a service member away from the parent command to perform duties at a different command.

TCP/IP (Transmission Control Protocol/Internet Protocol)

The collection of transport and application protocols used to communicate on the Internet and other networks.

URL (Uniform Resource Locator)

An address or location of a site to be viewed on the WWW.

WEB BROWSER (See BROWSER)**WWW (World Wide Web)**

Computers which are linked and which provide hyperlinks to Internet resources worldwide.

LIST OF REFERENCES

- Beer, M. A. (1988). Leading Change Harvard Business School. (9-488-037)
- Burleson, D. (1994). Managing Distributed Databases. New York: John Wiley & Sons
- Christensen, R. (1996, May). Intranet: Misspelling...or Megatrend Atlanta Computer Currents
- The CIO Insider URL: http://www.cio.com/WebMaster/sem3_benefits.html
- Fleet, D., Warren, M., Chia-Hsun Chen, J., Stojanovic, A. (1997). Teach Yourself Active Database Programming in 21 Days Indianapolis: Sams.net Publishing.
- Forta, B. (1997). Cold Fusion Web Database Construction Kit Indianapolis: Que Publishing. p. 10
- Government Accounting Office. (1994). Executive Guide: Improving Mission Performance Through Strategic Information Management and Technology (GAO/AIMD-94-115).
- Hoffer, J. A., George, J. F., Valacich, J. S. (1996). Modern Systems Analysis and Design. Menlo Park: Benjamin/Cummings
- Lane, E. (1996). Organization and Standard Operating Procedures (ESUALAMEDAINST 5400.1B)
- Lawrence, P. R. (1954). How to Deal with Resistance to Change Harvard Business Review
- Mnemonic, J. (1997, December). Access Control With a Database The ASP Hole URL: <http://asphole.stellarvision.com/asphole/default.asp?a=showarticle&id=6&page=2>
- Senge, P. M. (1990). The Fifth Discipline. New York: Doubleday.
- U.S. Coast Guard Office of Architecture and Planning (G-SIA), (1997). Strategic Information Resources Management Plan (FY97); Appendix A: Jumbo SIRMP business Model (COMDTPUB 5230.46)
- USCG Commandant (1997). USCG Intranet - CGWEB (COMDTINST 5230.57)

BIBLIOGRAPHY

Guengerich, S., Graham, D. (1997). Building the Corporate Intranet. New York: Wiley Computer Publishing

Hills, M. (1997) Intranet Business Strategies. New York: Wiley Computer Publishing

Intranet Journal: URL <http://www.intranetjournal.com/>

Kroenke, D. (1995). Database Processing. New Jersey: Prentice Hall

60 Minute Intranet Kit, Microsoft Corporation URL: www.microsoft.com/office/intranet

Web Techniques Magazine: URL <http://www.webtechniques.com/>

INITIAL DISTRIBUTION LIST

1. Defense Technical Information Center 2
8725 John J. Kingman Road, Suite 0944
Fort Belvoir, VA 22060-6218
2. Dudley Knox Library 2
Naval Postgraduate School
411 Dyer Road
Monterey, CA 93943-5101
3. Prof. Suresh Sridhar (Code SM/Sr) 1
Naval Postgraduate School
Monterey, CA 93943-5103
4. Prof. Carl Jones (Code SM/Js) 1
Naval Postgraduate School
Monterey, CA 93943-5103
5. Commandant (G-SRF) 1
2100 Second Street SW
Washington, DC 20593-0001
Attn: CDR J. Hall
6. Commandant (G-SIA) 1
2100 Second Street SW
Washington, DC 20593-0001
7. Commanding Officer 1
USCG ESU Alameda
BLDG #21, Coast Guard Island
Alameda, CA 94501-5100
8. Commanding Officer 1
USCG Research and Development Center
1082 Shennecossett Road
Groton, CT 06340-6096
9. Commanding Officer 1
USCG Operations Systems Center
175 Murall Drive
Martinsburg, WV 25401-0200

10. LT Todd Hannah 4
103 Leidig Circle.
Monterey, CA 93940