

R  
249179

JPRS-TTP-84-022

3 August 1984

# Worldwide Report

TELECOMMUNICATIONS POLICY,  
RESEARCH AND DEVELOPMENT

19980826 124

**DISTRIBUTION STATEMENT A**

Approved for public release;  
Distribution Unlimited

DTIC QUALITY INSPECTED 2

**FBIS**

FOREIGN BROADCAST INFORMATION SERVICE

REPRODUCED BY  
NATIONAL TECHNICAL  
INFORMATION SERVICE  
U.S. DEPARTMENT OF COMMERCE  
SPRINGFIELD, VA. 22161

48  
A03

#### NOTE

JPRS publications contain information primarily from foreign newspapers, periodicals and books, but also from news agency transmissions and broadcasts. Materials from foreign-language sources are translated; those from English-language sources are transcribed or reprinted, with the original phrasing and other characteristics retained.

Headlines, editorial reports, and material enclosed in brackets [ ] are supplied by JPRS. Processing indicators such as [Text] or [Excerpt] in the first line of each item, or following the last line of a brief, indicate how the original information was processed. Where no processing indicator is given, the information was summarized or extracted.

Unfamiliar names rendered phonetically or transliterated are enclosed in parentheses. Words or names preceded by a question mark and enclosed in parentheses were not clear in the original but have been supplied as appropriate in context. Other unattributed parenthetical notes within the body of an item originate with the source. Times within items are as given by source.

The contents of this publication in no way represent the policies, views or attitudes of the U.S. Government.

#### PROCUREMENT OF PUBLICATIONS

JPRS publications may be ordered from the National Technical Information Service, Springfield, Virginia 22161. In ordering, it is recommended that the JPRS number, title, date and author, if applicable, of publication be cited.

Current JPRS publications are announced in Government Reports Announcements issued semi-monthly by the National Technical Information Service, and are listed in the Monthly Catalog of U.S. Government Publications issued by the Superintendent of Documents, U.S. Government Printing Office, Washington, D.C. 20402.

Correspondence pertaining to matters other than procurement may be addressed to Joint Publications Research Service, 1000 North Glebe Road, Arlington, Virginia 22201.

3 August 1984

# WORLDWIDE REPORT

## TELECOMMUNICATIONS POLICY, RESEARCH AND DEVELOPMENT

### CONTENTS

#### ASIA

##### PEOPLE'S REPUBLIC OF CHINA

Newspaper Facsimile Transmission Developed  
(Wu Jincai; XINHUA Domestic Service, 19 Jun 84) ..... 1

Briefs  
New Telecommunications Fiber Developed ..... 3

##### THAILAND

Ericsson Axe Switching Stations Ordered From Sweden  
(Elisabeth Sandlund; SVENSKA DAGBLADET, 20 Jun 84) ..... 4

#### EAST EUROPE

##### GERMAN DEMOCRATIC REPUBLIC

GDR Coordinates 'Interkosmos' Research Project  
(W. L. Bykow, W. Liebsch; NACHRICHTENTECHNIK  
ELEKTRONIK, No 4, 1984) ..... 5

##### HUNGARY

Situation of Telecommunications Industry Viewed  
(MAGYAR HIRLAP, 26 Jun 84) ..... 17

Deficiencies in Telephone Service Discussed  
(Agoston Braun; MAGYAR HIRLAP, 24 Jun 84) ..... 20

LATIN AMERICA

BARBADOS

Nation's Second Earth Satellite Planned in Next 4 Years  
(Patrick Ward; THE NATION, 20 Jun 84) ..... 23

ECUADOR

Briefs  
Telephone Exchange Equipment From Sweden ..... 24

NEAR EAST/SOUTH ASIA

BANGLADESH

Representative Addresses UN Information Committee  
(THE BANGLADESH OBSERVER, 21 Jun 84) ..... 25

INDIA

Briefs  
TV Transmitters Commissioned ..... 26  
66th TV Transmitter ..... 26

SUB-SAHARAN AFRICA

ZAMBIA

Briefs  
New 500 KW Transmitter Site ..... 27

USSR

Nonaligned Nations Set Up News Agency Pool  
(APN DAILY REVIEW, 16 May 84) ..... 28

WEST EUROPE

EUROPEAN AFFAIRS

Controversy Over Luxembourg GDL System Outlined  
(Michael Wett; FRANKFURTER ZEITUNG/BLICK DURCH DIE  
WIRTSCHAFT, 7, 8 Jun 84) ..... 29

Role of TV-Sat, TDF-1  
Channels, Costs Involved

FINLAND

Mobira Firm Finds Success in Exports of Mobile Phones to U.S. (Heikki Arola; HELSINGIN SANOMAT, 5 Jun 84) .....	34
Teleste Developing Third Generation of Satellite Antennas (Birgitta Jernvall Ingman; HUFVUDSTADSBLADET, 30 Jun 84)	39

SWEDEN

Telecommunications Agency To Spend Record Amount in 1984-85 (Bo Ostlund; SVENSKA DAGBLADET, 8 Jun 84) .....	43
--	----

PEOPLE'S REPUBLIC OF CHINA

NEWSPAPER FACSIMILE TRANSMISSION DEVELOPED

OW200424 Beijing XINHUA Domestic Service in Chinese 0155 GMT 19 Jun 84

[By reporter Wu Jincai]

[Text] Beijing, 19 Jun (XINHUA) -- In China, more and more readers are paying attention to how fast the newspapers arrive. Time has always been a factor determining the success or failure of a certain event. Seeing the newspaper and obtaining information promptly may help people make early decisions on handling their affairs and making arrangements for their livelihood.

Newspaper editorial departments are most concerned about sending newspapers to the readers as soon as possible.

In recent years, more and more newspaper offices file applications with the telecommunications departments for the utilization of the advanced technology of facsimile transmission to send a copy of their newspaper to the printing centers in various localities. Facsimile technology began to serve the press some 70 years ago, but it was not popular. During the transmission, it is only necessary to put an original copy on the facsimile machine, and after an hour or so, it will be transmitted to a place thousands of miles away. The copy at the receiving site is as clear as the original. Then, the local printing workers begin work, and readers, living far from Beijing, will be able to read the central newspapers on the same day as the people in the capital.

Currently, nine newspapers in the capital are publishing radiophotographic editions in other cities. Some of the newspapers have published their radiophotographic editions in as many as 14 localities, such as Urumqi, Kunming, Chengdu, Chongqing, Guangzhou, Nanning, Changsha, Wuhan, Fuzhou, Hangzhou, Nanjing, Nanchang, Lanzhou, and Guiyang. Some newspapers such as JINGJI CANKAO are only being transmitted to one locality, while most, such as GUANGMING RIBAO and GONGREN RIBAO, send their radiophotographic editions to several cities. Printed newspapers are generally transported by train to cities near Beijing, such as Tianjin and Shijiazhuang. Paper matrix is usually sent by air to relatively distant cities, but with transport facilities such as Shanghai, Jinan, Shenyang, and Changchun, so that newspapers are printed and published locally.

By utilizing the aforementioned 3 methods, the people in 21 cities at the provincial capital level in China are able to read RENMIN RIBAO on the same day. The delivery of other newspapers to various localities has also been more prompt than before. Many newspaper publishers point out: Of all methods, the most advanced is facsimile technology. China's telecommunications departments are busy developing technical transformation, and expanding the capacity of facsimile circuits, so that more newspapers will reach various localities on time by means of this advanced technology, and more people in remote areas will be able to learn what has happened at home and abroad more promptly.

It is reported that Shanghai's WEN HUI BAO will soon publish its radio facsimile copies in Beijing, and become the first newspaper published in Beijing from another locality through radio facsimile transmission.

CSO: 5500/4138

PEOPLE'S REPUBLIC OF CHINA

BRIEFS

NEW TELECOMMUNICATIONS FIBER DEVELOPED--Shanghai, 16 Jul (XINHUA)--Scientists in Shanghai have developed an optic fiber which can be used to transmit TV and 1,900 telephone calls. Specialists approved the results of the tests conducted by the Institute of Silicate Research of the Chinese Academy at the weekend and said the new fiber measured up to world standards. The new product is of the long wave length fourth order group multiple mode graded kind. [Text] [OWL61346 Beijing XINHUA in English 1155 GMT 16 Jul 84]

CSO: 5500/4139

ERICSSON AXE SWITCHING STATIONS ORDERED FROM SWEDEN

Stockholm SVENSKA DAGBLADET in Swedish 20 Jun 84 p IV

/Article by Elisabeth Sandlund/

/Text/ Ericsson has received an order valued at 460 million Swedish kronor from Thailand's Telecommunications Administration (TOT). The order is for new and expanded AXE exchanges for 28 cities in Thailand.

The order means that the number of digital AXE lines in Thailand will be doubled to about 275,000. The first AXE exchange is located in Chiang Mai and went into operation in March of this year.

The equipment will be manufactured in Sweden and mainly at Ericsson's factories in Norrkoping and Katrineholm. Deliveries will begin in 1985.

The order includes a number of so-called rural subscriber installations designed for the more sparsely-populated parts of the country. These affect between just over 100 and 2,000 subscribers and are placed in containers.

The AXE system has not been sold to 50 countries. Almost 10 million lines are in operation or on order. There are still a number of countries which have not chosen a telephone system and where Ericsson has chances for making sales. Many negotiations, however, are concerned with continued deliveries to countries which have already decided to choose the AXE.

12562

CSO: 5500/2728

GDR COORDINATES 'INTERKOSMOS' RESEARCH PROJECT

East Berlin NACHRICHTENTECHNIK ELEKTRONIK in German Vol 34, No 4, 1984  
pp 122-126

[Article by W. L. Bykow, Moscow; W. Liebsch, East Berlin]

[Text] The entire development of radio technology is inseparably linked with the solution of scientific and practical tasks aiming at opening up new frequency bands. The exploitation of new frequency bands not only expands the transmission capacity of presently operating radio engineering systems but because of the specific characteristics of these bands it also opens up techniques for creating what are basically new or more perfect systems of communication transmission.

Presently existing satellite systems meeting the communications needs of our national economies are for the most part operated in the 6/4 GHz frequency range. But this frequency range is already for practical purposes fully occupied. There are already more than 220 communications satellites listed on the geostationary orbit which serves as the primary orbit for communications satellites. The positioning of new satellites in this orbit in the frequency range 6/4 GHz requires careful international coordination extending over a long period of time. It is not possible to have a substantial increase in the capacity of the systems presently operating or planned for operation in this range.

For these reasons increasing attention has been given recently worldwide to the opening up of new frequency bands above 10 GHz--primarily in the ranges 14/11 GHz and 30/20 GHz.

In these ranges the Radio Implementation Ordinance of the International Communications Union has assigned frequency bands to the fixed radio services. These bands contain almost five times the band width which is available in the 6/4 GHz frequency range.

However, the transition to higher frequencies is associated with a deterioration of the energy budget of satellite radio paths as a result of the influence of certain external factors--produced by an increased attenuation and depolarization of the radio waves and a change in the signal structure. Generally the opening up of new frequency ranges is a complex problem because in

addition to the investigation of peculiar features of the radio wave propagation it is also necessary to develop all the radio engineering equipment--antennas, receivers, transmitters, measuring devices, etc., for these frequency ranges and this development must be preceded by the development of new structural elements.

#### 1. Experimental System for Opening up New Frequency Ranges Within the Context of the Interkosmos Program

In order to solve these problems rapidly and with high efficiency for the needs of the socialist countries, the participating countries Czechoslovakia, Romania, Bulgaria, Poland and the USSR under the leadership of the GDR, within the context of the working group for cosmic communication, as part of the Interkosmos program, have developed a project for an international communications satellite experimental system in the 11/14 GHz range and have jointly begun to carry out this project. The project provided at first only for the creation of national observation complexes which are equipped with experimental earth-based radio stations of various classes and with terrestrial observation paths. The project also provided for the development and stationing of two cosmic stations of the "Lutsch" type in the geostationary orbit.

In accordance with its assigned goal the experimental system, in addition to aiming at the comprehensive opening up of the above-mentioned frequency range, and at the same time was designed for preliminary research in the frequency ranges 20 and 30 GHz which prospectively shall also be employed for satellite radio services.

Consistently with the division of labor which had been agreed upon the USSR took over the development of the Lutsch Cosmic Station and the earth-based radio station of Class 1 having an antenna diameter of 12 meters; Czechoslovakia took over the development of the earth-based radio station of Class 2 with a 3-meter antenna and radiometers for the frequency ranges 11 and 18 GHz; the People's Republic of Bulgaria assumed responsibility for the transmitters and receivers for terrestrial observation pathways in the ranges 20 and 30 GHz; the People's Republic of Romania and the People's Republic of Poland assumed responsibility for the development of equipment designed to measure the intensity of precipitation and the GDR undertook the creation of a computer-supported measurement evaluation complex in addition to the development of narrow-band receivers for measuring radio wave attenuation over satellite pathways in addition to providing apparatus for data transmission from the individual observation points to the evaluation center. In addition, the GDR was given the task of overall coordination of the activities.

In 1980 after consultation with the national coordinating organs of the Interkosmos program it was resolved, jointly with the participating countries to create an international test complex in the region of the town called Dubna in the USSR. This test complex is becoming the center of the international experimental system and it is here that joint scientific-experimental investigations are being conducted with the aim of opening up new frequency ranges.

In this way it has been possible to concentrate the principal facilities in one location and to limit the equipment of the national observation sites of the participating countries essentially to the scope necessary for the investigation of propagation conditions prevailing at the individual local sites of the earth-based radio stations. Figure 1 shows the structure of the international experimental system.

Practical studies toward the creation of the international test complex in Dubna began in the middle of 1981.

The first satellite with a "Lutsch" space station was launched in March of 1982 and stationed in the geostationary orbit at 53° east longitude (E.L.) and after completion of the testing it was made available for studies within the context of the Interkosmos program.

An additional satellite having an 11/14 GHz transponder was launched in 1983 and stationed at 14° west longitude (W.L.). The international test complex was officially opened and placed in operation in September 1982.

## 2. International Test Complex

### 2.1. Structure and Tasks

The Dubna International Test Complex makes possible the effective performance of scientific and experimental investigations designed to open up new frequency ranges for space communications links, with special emphasis being placed upon:

- i. complex investigation of radio wave propagation conditions in the frequency ranges above 10 GHz over terrestrial and satellite paths; acquisition of long-term statistical data for the absorption and depolarization of radio waves in the troposphere, measurement of precipitation intensity distribution and the temperature of cosmic noise; determination of the correlation between these factors;
- ii. evaluation of the effects of the troposphere and of meteorological conditions upon information transmission over satellite paths in frequency ranges above 10 GHz; investigation of prospective procedures of information transmission and procedures of multiple access together with their adaptation to the variable atmospheric factors;
- iii. testing of new radio engineering equipment for earth-based radio stations and satellites for systems of the fixed-station satellite radio service and systems of nonfixed satellite radio which are being developed within the context of international cooperation;
- iv. workup and experimental testing of principles and recommendations for the construction of prospective communications satellites and satellite radio systems intended for international and national use by participating countries in the Interkosmos program.

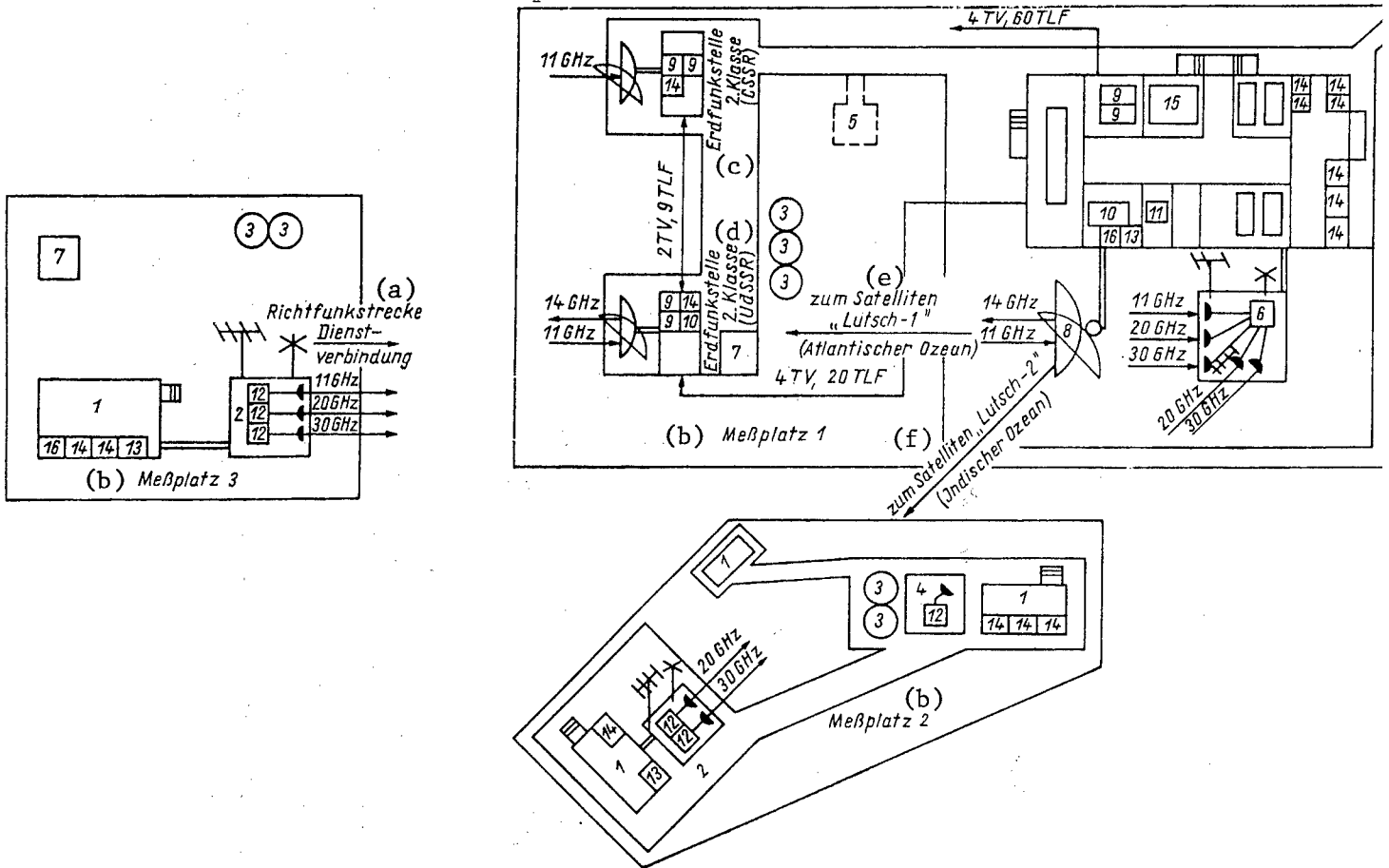

Fig. 1. International experimental system for space communications in the Interkosmos program.

- Key:
- a. Microwave service link
  - b. Observation site ...
  - c. Earth-based radio station Class 2 (Czechoslovakia)
  - d. Earth-based radio station Class 2 (USSR)
  - e. To the "Lutsch-1" satellite (Atlantic Ocean)
  - f. To the "Lutsch-2" satellite (Indian Ocean)

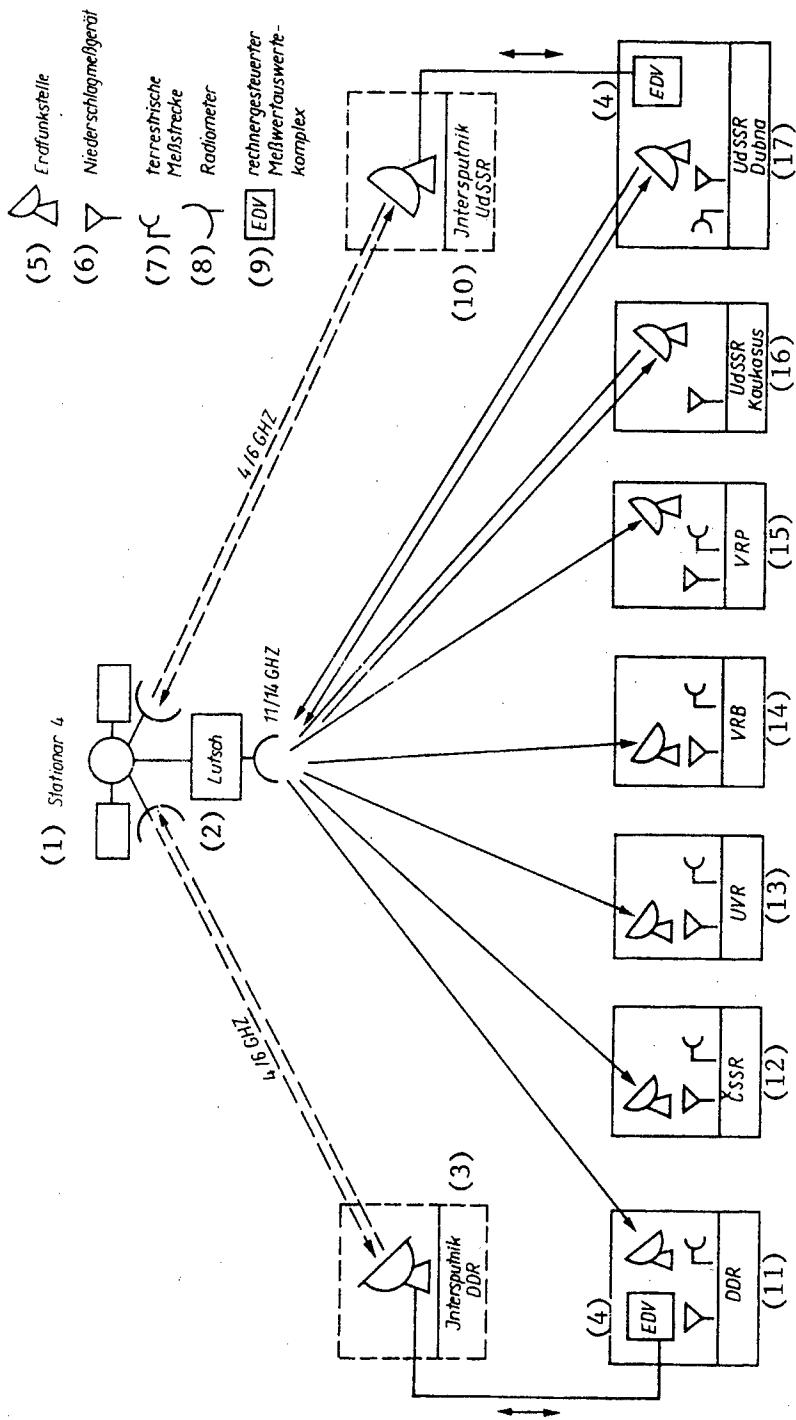

Fig. 2. Dubna International Test Complex--structural scheme: [Fig. 1] 1--engineering building (USSR); 2--mast for microwave service link, terrestrial observation path and service links (USSR); 3--precipitation measuring device (Poland/Romania); 4--adjustable mast (USSR); 5--radiometer (Czechoslovakia); 6--receiver for terrestrial observation paths (Bulgaria); 7--meteorological station (USSR); 8--antenna station Class 1 (USSR); 9--receiving equipment (GDR/USSR/Czechoslovakia); 10--transmitting equipment (USSR); 11--observation processing and evaluation complex (GDR); 12--transmitter for terrestrial observation paths (USSR/Bulgaria); 13--microwave station (USSR); 14--measuring equipment (USSR); 15--6-channel converter for meteorological data (Poland); 16--Ursatrans data transmission equipment (GDR).

Key to Figure 2:

- |   |                                    |
|---|------------------------------------|
| (1) Stationary 4  | (10) Intersputnik USSR             |
| (2) Lutsch  | (11) GDR                           |
| (3) Intersputnik GDR  | (12) Czechoslovakia                |
| (4) EDP   | (13) People's Republic of Romania  |
| (5) Earth-based radio station                               | (14) People's Republic of Bulgaria |
| (6) Precipitation measuring device                          | (15) People's Republic of Poland   |
| (7) Terrestrial observation path                            | (16) USSR Caucasus                 |
| (8) Radiometer  | (17) USSR Dubna                    |
| (9) EDP--computer-controlled measurement evaluation complex |                                    |

The international test complex is located in the vicinity of Dubna 128 km north of Moscow and includes three observation sites (see Figure 2). Measurement site No 1 is located on the terrain of the already operative international center for cosmic communication links in Dubna. At this observation site there are situated:

- i. the engineering building of the observation site (see frontispiece) in which the principal equipment of the test complex is housed. This latter includes the transmitting and receiving equipment of the Class 1 station, various laboratories and the central measurement evaluation complex;
- ii. an antenna system for the Class 1 station having a mirror diameter of 12 meters (Figure 3) [Photo not reproduced];
- iii. earth-based radio stations of Class 2 in container design with an antenna diameter of 3 meters (Figure 4) [Photo not reproduced] and 4 meters;
- iv. a steel lattice tower having a height of 30 meters for terrestrial observation paths; on the upper platform of the mast there are antennas and receiving equipment for measurement paths in the ranges 11, 20 and 30 GHz;
- v. precipitation measuring devices of various types (see Figure 3) as well as a meteorological station;
- vi. a radiometer for measuring the temperature of cosmic noise in the ranges 11 and 20 GHz.

The observation site No 2 is located at a distance of 1 km from observation site No 1 in the azimuthal direction toward the Lutsch-2 space station (53° E.L.). The principal constituents are transmitters for the terrestrial observation paths in the 20 GHz and 30 GHz range together with precipitation measuring devices. In addition, at this observation site there is a calibrating complex which is intended for calibration of antenna systems and for measuring parameters of the radiated signals. The observation site No 3 lies 12 km away from observation site No 1 in the azimuthal direction toward the Lutsch-1 space station (14° W.L.). At this observation site there are also installed transmitters for terrestrial observation paths in the ranges of 11, 20 and 30 GHz, in addition to precipitation measuring devices.

Further precipitation measuring devices are located along the line between observation sites 1 and 3. They serve for the investigation of the three-dimensional structure of precipitation regions. All three observation sites are coupled with microwave links and equipped with radio equipment which permit telephone conversations between the observation sites.

The transmission of data from the individual observation sites to the central evaluation complex is accomplished by means of structural components of the Ursatrans (GDR) system via telephone channels. The Dubna International Test Complex and the national observation complexes of the participating countries are located in the second climatic zone (in accordance with the CCIR classification) which is characterized by a moderate intensity of precipitation. Since the precipitation statistics and the associated statistics for radio wave attenuation depend essentially upon the geographic location of the receiving point it is also of practical interest to record signals at points which are located in other climatic zones.

In order to acquire statistical data for regions of high precipitation intensity there is being set up within the context of the Dubna International Test Complex a measurement site located in the fifth climate zone on the coast of the Black Sea in the vicinity of Sochi. This observation site is equipped with apparatus for recording precipitation intensity and signal attenuation; its principal constituent is a transmit-receive station of Class 2 with the aid of which the measured parameters are transmitted via the Lutsch space station at observation site No 1 to Dubna and are then automatically fed to the measurement evaluation complex of the international test complex.

The construction of the engineering building of the international test complex as well as the assembly of the equipment has been carried out by the Soviet side. The radio engineering equipment was developed and manufactured jointly by the participating countries. Since all data which are acquired on the terrestrial and satellite paths as well as the results of computer-supported long-term statistical evaluation are stored in the memory of the computer at observation site No 1 it is possible for failures at the computer complex to result in loss of data. To increase the security of the data acquisition and storage an equivalent computer complex is provided at the national observation site of the GDR in Neu Golm (in the vicinity of Fuerstenwalde).

Both computer complexes are continuously linked to one another via a duplex telephone channel in the Intersputnik system; in this way there is a guarantee of continuous data exchange and when necessary of the requisite substitute circuits.

## 2.2. Earth-Based Radio Stations

In working out the projects for the international experimental system it was agreed to develop experimental earth-based radio stations with various different quality ratings.

The stations of Class 1--central (or base) stations with a 12-meter antenna--are provided for transmission and reception of all types of information even

including television and telephone signals as well as measurement signals for the investigation of radio wave attenuation and service channel links.

The stations of Class 2--peripheral stations having an antenna of from 3 to 4 meters--are for the reception of television signals, for telephone traffic with low transmission capacity and for the reception of measurement signals used in the investigation of radio wave attenuation.

At the international test complex sample stations of the two types were installed.

The earth-based radio station of Class 1 was developed in the USSR; it consists of an antenna system with a 12-meter parabolic mirror, a Klystron transmitter with an output power of 1.5 kw and a receiver having a low noise amplifier which is located in a building immediately adjacent to the antenna dish. The antenna system rests on a tubular structure cylinder which is immediately next to the engineering building.

Satellite tracking by the antennas can be either programmed or performed automatically while using an electronic scanning procedure or with the aid of an extreme value automaton.

The band width of the radiator system and of the wave guide amounts both in the transmission and reception frequency range to 500 MHz. The band width of the parametric amplifier amounts to 250 MHz and the band width of the transmitter amounts to 50 MHz.

The engineering equipment currently set up in the station guarantees operation in a broad band tube and permits transmission and reception of a frequency modulated TV signal or the transmission of 24 duplex telephone channels with the aid of the SCPC process (single channel per carrier) while using frequency modulation in the frequency multiplex (Figures 5 and 6) [Photos not reproduced]. The engineering parameters of the station are shown in Table 1.

The earth-based radio station of Class 2 (Figure 4) was developed in Czechoslovakia. It includes an antenna system having a mirror diameter of 3 meters and a standard transport container with radio engineering equipment and auxiliary equipment. The rotating and support apparatus of the antenna permits a rough dish positioning in the angular range  $\pm 180^\circ$  in azimuth and an exact antenna tracking following the satellite within the limits  $\pm 10^\circ$  in azimuth and  $0^\circ$  to  $+90^\circ$  in elevation. The Class 2 earth-based radio station in Dubna is designed as a receiving version. The SHF input component is located in a hermetically sealed housing at the rear of the antenna dish. It consists of a low noise parametric amplifier and an 11 GHz/70 MHz frequency converter. The receiving equipment, the tracking equipment for the antennas are housed ... [text missing in photocopy].

In the existing equipment versions the station guarantees the reception of a TV signal and of a measurement signal for wave propagation measurements over satellite transmission paths. The design and the parameters of the

measurement signal receiver are the same as in the Class 1 station. The engineering parameters of the station are likewise contained in Table 1.

The two earth-based radio stations are used in the program to carry out experiments over the international experimental complex. This means that the earth-based radio station of Class 1 transmits in addition to information signals a measurement signal on the 14.341 GHz frequency (unmodulated carrier) which is received and amplified by the Lutsch space station and radiated at the 11.541 GHz frequency and used for measuring radio wave attenuation at the national observation sites of the participating countries. At the Dubna International Test Complex the signal can be received both by the earth-based radio station of Class 1 and also by the Class 2 station. For signal evaluation 70 MHz "search-run" receivers (evaluation band width 3 kHz, search-run range  $\pm 1.5$  MHz) are used which were especially developed for this purpose in the GDR.

### 2.3. Terrestrial Observation Paths

For measuring radio wave attenuation over terrestrial paths and for determining the correlations with attenuation over satellite transmission paths two terrestrial measurement paths were created within the context of the test complex. They had a length of 12 km and 1 km, respectively.

The terrestrial observation path having a length of 12 km is operated in the ranges 11, 20 and 30 GHz.

Antennas are employed having a diameter of 1 meter and constructed on the focal-ring principle.

The transmitters are equipped with semiconductor components. The engineering parameters of these paths are contained in Table 2.

The antenna systems of the terrestrial measurement paths and the transmit-receive equipment for 11 GHz were manufactured in the USSR and the transmit-receive equipment for 20 and 30 GHz was manufactured in the People's Republic of Bulgaria.

### 2.4. Precipitation Measuring Devices

The applicable CCIR recommendations standardize the average hour values and minute values of noise in communication channels. This presupposes a knowledge of average minute values of the precipitation distribution employed in calculating radio paths. For this it was necessary to develop new and rapidly responding measurement equipment.

To measure precipitation intensity two types of rain gauge are used at the international test complex:

- i. precipitation measuring devices based upon the condenser principle (developed in the People's Republic of Romania) and

- ii. whipping rain gauges (developed in the People's Republic of Poland).

In this way it is possible to compare their measured values and to increase measurement accuracy by deriving methodical and instrumental errors characteristic of the measuring devices of each type. Each rain gauge possesses an electronic adapter for linkage with the computer. In the Polish design of the rain gauge there are versions capable of autonomous operation with magnetic tape recording; in these versions the transport velocity of the magnetic tape depends upon the precipitation intensity so that it is possible to increase the time of tape cassette use by reducing the tape velocity during periods of low rain intensity.

## 2.5. The Measurement Evaluation Complex

The great number of measured parameters, the need to record seconds values or minutes values over long periods of time (in order to acquire long-term statistics) and the goal of determining correlations between these parameters impose high demands upon the equipment used to record and evaluate the measurements. The manual evaluation of oscillograph records is practically impossible with so great a volume of data. In order to solve this problem a special automatic evaluation complex has been developed in the GDR on the basis of a Robotron 4201 minicomputer and the associated software required for this processing operation has been developed.

The installation (Figures 7 and 8) [Photos not reproduced] consists of the actual computer which carries out the processing operation, two magnetic drum storages, peripheral equipment for input and output of program data and also two control and measurement panels which serve for analog recording of measured values on oscillograph paper and also for digitalizing measurements for input into the computer. The described complex permits the interconnection of up to 16 different observation sites and carries out their evaluation in an interval of 1 second; the capacity of the computer memory amounts to 16,000 words of 16 bits each; the capacity of each magnetic drum storage amounts to 69,000 words.

The evaluation program is so constructed that the measured data are first input into the computer's memory and stored there for 72 hours. Within this time it is possible to carry out a correction of measured values for the purpose of eliminating possibly existing errors which can be brought about through equipment failure or through power supply failures. After 72 hours data are condensed and then put into the primary storage (magnetic drum storage) used to obtain long-term statistics and also for automatic computation of the correlation coefficient relating to the individual series of measurements.

## 2.6. Program of Experimental Studies at the International Test Complex

The program of experimental studies at the international test complex arranged for the period 1982 through 1985 includes nine experiments which encompass all essential aspects of the complex of problems relating to the opening up of new frequency ranges. These experiments are carried out in

accordance with detailed programs and methodologies. The experiments have varying durations and some investigations in the domain of wave propagation (e.g., attenuation, precipitation and depolarization measurements) last for several years.

For each experiment a scientific leader has been named from one of the participating countries.

In evaluating the experiments attention is given both to the measurements obtained at the international test complex and also those obtained at the national observation sites of the participating countries and these measurements are compared with one another. In the meantime a start has been made with the performance of the scientific experiments.

The creation of the international test complex is an important contribution by the participating countries of the Interkosmos program to the scientific and practical opening up of space for peaceful purposes.

Table 1. Technical Parameters of the Research Facility's Earth Station

Parameter	Class 1 Station	Class 2
Antenna diameter in m	12	3
Range frequencies in GHz		
--for transmitting	14.0 to 14.5	--
--for receiving	11.45 to 11.7	11.45 to 11.7
Antenna direction power in dB		
--for transmitting	60	--
--for receiving	59.3	48.2
Equivalent noise temperature		
--of the receiver in K	250	200
Quality factor of earth station under clear-sky conditions, when coverage angle is $10^\circ$ in dB/K	32.6	23.2
Output power of transmitter in kW	1.5	--
EIRP of station in dBW	89.5	--

Table 2. Technical Parameters of Terrestrial Measured Sections

Parameter	11 GHz	20 GHz	30 GHz
Output of transmitter in mW	300	67	50
Antenna direction power (with protective sheathing of Antenna) in dB	38.5	43	46
Limiting sensitivity of receiving device in dBW	-100	-126	-123
Attenuation range of the signals to be measured in dB	34	55	52

PHOTO CAPTIONS

1. p 124, left. Antenna system of the earth-based radio station of Class 1; in the foreground measuring devices for measuring precipitation intensity.
2. p 124, right. Earth-based radio station of Class 2.
3. p 125, top. [Caption missing in photocopy]
4. p 125, bottom. Earth-based radio station of Class 2, transmitter equipment.
5. p 126, left. Computer-supported measurement evaluation complex.
6. p 126, right. Computer-supported measurement evaluation complex.

8008

CSO: 5500/3014

## SITUATION OF TELECOMMUNICATIONS INDUSTRY VIEWED

Budapest MAGYAR HIRLAP in Hungarian 26 Jun 84 p 7

/Unsigned article: "Session of National Assembly Committees; On the Agenda--the Telephone Network"

/Text/ Representatives on the industrial, construction and transportation committees heard a report yesterday about the status of the signal technology industry and the telephone network. The joint session itself indicates the importance of the theme, and the fact that the developments cannot be thought about without a knowledge of all the affected areas. The debate which developed proved that the lack of telephones causes the most serious problems in this area.

The written report established that the Post Office receives about 30-32 percent of the production of the telecommunications industry, and that the export ratio is significant. So when we talk about the uneven performance of the industry it may be that the domestic area is being forced into the background temporarily because of export. It is also a fact that the Hungarian Post Office has not had sufficient money evenly, so the orders are submitted in waves, and sometimes these exceed the possibilities of the industry. At other times there has not been enough work. The shortage in this area has had an effect; for example, there have virtually never been enough communications cables, and the manufacture of landline transmission equipment can be regarded as a tension point also. In addition, the developments based on license purchases started with delays of 1 to 1½ years--for various reasons.

As a result of all this there has developed a situation so that when we evaluate the Sixth 5-Year Plan we can report only the most mixed results. The average indexes are favorable--the telephone network developed in the Sixth 5-Year Plan above the planned level. But even with this the international backwardness could hardly be moderated....

In his verbal commentary Zoltan Koteles, deputy minister of industry, emphasized that telecommunications is one of the stressed areas of the central economic development program. But the tensions cannot be liquidated immediately; in any case better cooperation of the Post Office and the industrial enterprises could ease the problems. Where necessary a central stand will be taken. Thus, for example, the domestic area received unambiguous priority in cable manufacture, even at the expense of export.

Bela Doros, deputy chairman of the Hungarian Post Office, emphasized that the development of telecommunications means not only maintaining and expanding the telephone network but also includes data transmission and telex. There is much to be done in these areas. Experience shows that the operability of the telephone network has deteriorated. This must be stopped urgently, because otherwise it is in vain to bring more settlements into the telephone network, the service will only appear to improve. According to calculations about 9-7 billion forints must be spent on reconstruction in the Fourth 5-Year Plan [as published], and this did not give a single new telephone to those requiring one. As for the cooperation of industry and the Post Office, it is true that the backwardness cannot be put to the account of industry only; among the causes the lack of capital played at least as great a role. At the same time, the Post Office was forced to transfer a 110 million forint developmental fund to the cable factory to ease somewhat the financial difficulties of the enterprise.

Following the verbal commentaries the representatives gave their opinions. Antal Kangyalka (Csongrad County) asked if there was a way to replace the many sorts of import cable with domestic cable. At the same time, he noted--and a number of his fellow representatives joined in this--that the development of telecommunications cannot be imagined without a retraining of experts. Ferenc Herczeg (Borsod-Abauj-Zemplen County) described in dramatic tones what social tensions might arise due to the shortage of telephones. It would be correct to better coordinate the telecommunications industry centrally, he noted, because in addition to the restricted assets there are also parallel developmdnts which tie down energies superfluously. Naturally this central coordination should not decrease enterprise independence, but at the same time it would make it possible to start more intensive capital regrouping among the affected enterprises. He asked that a determined position be taken in the matter of cable manufacture for it can be seen clearly that the enterprise will not have free developmental resources in the Seventh 5-Year Plan either. It is intolerable that this bottleneck should determine the development of the telephone network, because the backwardness here can cause gigantic material damage to the economy.

Laszlo Mezei (Budapest) noted that in the beginning there are no telephones in the newly-built residential areas, so there is no way to call for help. He recommended that mobile telephones be installed in such places which could be used to call the most important institutions. Gabor Szilagyi (Hajdu-Bihar) proved with figures that the telephone is representing an ever greater social problem in Hungary. In 1970 they recorded 139,000 people waiting for telephones; this year the number is 380,000. The long-range conception of the Post Office, up to the year 2000, is aimed only at reaching the present European average.

Ferenc Gajdos (Budapest), Imre Koltai (Pest County), Janos Reidl (Somogy) and Imre Antal (Pest County), among others, noted that in a shortage situation it is extraordinarily important that freed or newly-established telephone lines be assigned in a circumspect manner. At present it often happens that those in greatest need do not get them.

In response Zoltan Koteles and Bela Doros pointed out that the developmental trend of telecommunications is clearly seen. But the Seventh 5-Year Plan is only now being sketched out, so the developmental resources available are not known in their entirety either. It is certain that this area counts as a stressed developmental goal.

8984

CSO: 5500/3019

## DEFICIENCIES IN TELEPHONE SERVICE DISCUSSED

Budapest MAGYAR HIRLAP in Hungarian 24 Jun 84 p 3

/Article by Agoston Braun: "Hellp, Central? Difficult Connections"

/Text/ For a long time yet domestic interurban and international telephone calls will require manual connections. Very much depends on the postal employees sitting in the exchanges. The operators, most of them women, know very well that the slightest mistake or discourtesy in the course of their work can have serious consequences. But do the conditions make it possible for them to meet the strict requirements over a long time?

The green lamp means that due to the load one must wait at least  $\frac{1}{2}$  an hour; when the red light goes on it means all lines are occupied; following the yellow light the lines being requested cannot be used. In the Budapest domestic exchange of the Interurban Telephone Directorate the names of the more important stations can be read on a great panel dividing the room in two--and at least two lamps burn beside the great majority of the cities. If you want to call Eger or its environs or the Miskolc zone you can count yourself fortunate for the moment; but the minute quickly passes because first the green and then the red lamps go on for the two county capitals also.

"There are 98 work positions here and at this time, in the forenoon peak period, virtually all of them are overloaded," explained Laszlo Szegedi, deputy director for operations. "The situation is entirely different at night or on weekends when even a few people can handle the traffic easily."

## Ten Thousand Calls

A microfilm directory also helps the work of the telephone operators; of the earlier cord switchboards only one is now orphaned in the corner of the hall, to be wondered at as a museum relic. But independent of this the 9,000 to 10,000 calls per day, the great majority of which fall between 0800 and 1600 hours, place no small burden on the workers.

"We can go out for 10 minutes for breakfast; we get 20 minutes for lunch," the ladies complain. "Often the two times come so close together that we do not starve. And we must treat the customers like painted eggs--however irritated they are--or we can lose all our sliding wages."

Laszlo Szegedi had the following opinion about all this:

"The work schedule really is very tight because each operator, as a daily average, must handle 12 connections per hour. At peak times it is not rarely 20 or 25 connections, and certainly this tempo permits no relaxation. We cannot make allowances from the behavioral norms, for in the well-known unfortunate telephone situation we cannot make the lives of the subscribers more difficult by talking to them in an irritated manner."

A special staff watches that connections are made according to the rules and watches for a courteous tone. They spot check and work positions; and the worker can listen to the recording of a questioned conversation if she does not believe the warning or wants to learn from her own offense. Those who make serious mistakes or are not inclined to change their behavior fall into the net of supervision ever more frequently and if in the end they are "irredeemable" they are advised to seek another career, despite the 35 percent turnover at the domestic center.

Not a Sanatorium

"Our work is certainly not agreeable. At least they are happy to see us if we tell them they are getting extra pay for exemplary work noted in the course of an inspection," said Mrs Geza Berki, chief of the operations group. "In any case, our studies prove that 80 percent of the operators are working according to the rules; 6 to 10 percent of them offer outstanding performance. But there is always trouble with the remainder."

Laszlo Szegedi added: "A secondary school diploma and language knowledge are obligatory, but in the domestic service, because of the already mentioned labor shortage, we must make allowances and will accept applicants with an eighth grade education. Of course, then we try to get them to study further, but this is not always successful. Not even to speak of the fact that young people very easily leave us and find jobs at similar pay with easier work elsewhere."

Those working domestically say that compared to their work the international exchange is a veritable sanatorium. Marton Fetzler was amused to hear that:

"We must meet entirely different requirements here. In addition, holidays, nights and weekends are much heavier than for us. The extra pay, with the language supplement, is relatively attractive, but even so we are not much better off with personnel."

It is true, as I look around, in more than one place gray heads peer from under the hoops of the earphones, and people much younger than the average also handle the switches.

"In the summer, when vacations start and the nurseries and kindergartens close, there is an especially great need for the help of pensioners and university students willing to do temporary work," the chief of the exchange explained. "Fortunately we have a stable staff from both generations, so we do not easily get into trouble."

"I came here by chance more than 13 years ago, but since then I have liked my work very much. I make connections with places and continents where I have never been. It almost gives me the adventure of travel. Of course there are down periods too when one feels one cannot bear it anymore. Our technical conditions are certainly not among the best and sometimes no matter how I try I cannot satisfy the desires of the customer. Of course he does not know that, or is not inclined to admit it, and so he is agitated. One must be patient at such times, but sometimes one gets mad. For me it was in the 6th or 7th year after starting that a time came when I almost gave it up. Luckily my children were born then and so I could leave for a while. But if one of my colleagues were to tell me tomorrow that she would not do it any more I would not be a bit surprised."

At the End of the Field

The evaluation of the deputy director for operations sounds like this:

"We have modernized in recent years, but it subtracts much from the value of this that some of the domestic exchanges can receive our calls only amidst conditions which have not changed for decades. The cities of Gyor, Pecs, Szeged, Kecskemet, Debrecen and Miskolc have been connected into the international system; Eger will be added to the list in August. But for all this we are still lagging at the end of the field in Europe, and our workers feel the disadvantages of this as much as anyone."

That afternoon I wanted to make a telephone call to Bekescsaba, but I knew it was useless to try. I was there when they told Laszlo Szegedi that a work machine had cut the coaxial cable leading there and in the exchange I was under the spell of the persistently burning lamps. Only they were not inclined to sleep.

8984

CSO: 5500/3018

NATION'S SECOND EARTH SATELLITE PLANNED IN NEXT 4 YEARS

Bridgetown THE NATION in English 20 Jun 84 p 1

[Article by Patrick Ward]

[Text]

**BARBADOS is expected to get a new multi-million dollar Satellite Telecommunications Earth Station within four years.**

The station — Barbados' second — will vastly improve the island's communications links throughout the world and, at the same time, make Barbados the most important communications link in the Eastern Caribbean.

Chairman of the Cable and Wireless group of companies, Sir Eric Sharpe, said yesterday in an exclusive interview with THE NATION that the Barbados External Telecommunications Co. Ltd. (BET) had taken over the running of a very efficient operation and had deliberately developed the skills of Barbadians so that the company would be run with fewer expatriates.

He was pleased to see how efficiently the technical and commercial aspects of the operation were now.

Sir Eric said that there was a programme for significant capital investment over the next three to four years that would embrace the new satellite earth station, which would be the most

modern of its type to exist anywhere in the world.

It was only a matter now for the board of directors of the BET to consider, when they meet to review the capital requirements for the next five years which is expected to be in the millions of dollars, Sir Eric stated.

This earth station, he said, would have highly sophisticated equipment and would require skills of the highest order, but the BET would be well equipped to handle it, and it would also enhance the country, in terms of the services that would be offered, both industrially and domestically.

It will offer high speed data and voice contacts with the outside world while the construction of the station would boost employment.

The board of directors of the BET is expected to meet tomorrow. Government has a 25 per cent shareholding in the operation.

The other earth station at Bath, St. John, an Intelstat Satellite system linking Barbados directly with many parts of the world is one of the most modern and reliable telecommunications services.

Sir Eric also announced that BET is expected to widen and increase its share ownership. He said that BET would soon be discussing plans for such a step.

The Cable and Wireless chairman yesterday paid a courtesy call on the Governor-General, Sir Hugh Springer.

## BRIEFS

TELEPHONE EXCHANGE EQUIPMENT FROM SWEDEN--Ericsson has received an order from Ecuador valued at 80 million Swedish kronor for the delivery of telephone exchange equipment. The order is part of a 5-year plan to improve the country's telephone network. The contract from Ecuador's State Telecommunications Administration (IETEL) is for the delivery of 21 telephone exchanges of the type ARF to the capital city of Quito and to other places in the country. The equipment will be manufactured in Sweden and at the Ericsson concern's Mexican subsidiary. The sale is made with the support of Mexican export credits. Installation work will be carried out by IETEL. /Text/ /Stockholm DAGENS NYHETER in Swedish 26 Jun 84 p 8/ 12562

CSO: 5500/2728

REPRESENTATIVE ADDRESSES UN INFORMATION COMMITTEE

Dhaka THE BANGLADESH OBSERVER in English 21 Jun 84 p 8

[Text] NEW YORK, June 20--Bangladesh has stressed the urgent need for establishment of a new world information and communication order in the United Nations Committee on Information. The 67 member Committee began its three-week long annual meeting on Monday in New York, reports BSS.

Lt. General Khwaia Wasiuddin Permanent Representative of Bangladesh to the United Nations is leading a four-member Bangladesh delegation to the Committee's session.

While addressing the Committee yesterday the leader of the Bangladesh delegation said that the rights to seek, receive and impart information and ideas had been affirmed by the universal declaration of human rights--as fundamental human rights, but the existing global information and communication system was not conducive to the enjoyment of these rights by the developing countries.

Ambassador Wasiuddin observed that the traditional monopoly and technological predominance of the western information agencies had resulted in the dependent status of the developing countries in the field of information.

He stressed the need for the establishment of a new world information and communication order for correcting the existing imbalance in the news flows to the disadvantage of the developing countries.

He said that the ultimate goal of the new order would be to strengthen peace and international understanding based on free circulation and broader dissemination of information guaranteed diversity of sources of information, greater balance in the dissemination of information and change in the state of dependence of the developing countries in the field of information.

Ambassador Wasiuddin called upon the UN Department of Public Information to enlarge its areas of active cooperation with various regional inter-governmental organisations, particularly the Non-Aligned Movement and the Organisation of the Islamic Conference, in their efforts to promote the establishment of the new world in information and communication order.

CSO: 5550/0022

## BRIEFS

TV TRANSMITTERS COMMISSIONED--A TV transmitter was commissioned today at Nellore in Andhra Pradesh. It will have a range of 2,000 square kilometers and will cover a population of nearly 500,000. [Excerpts] [Delhi Domestic Service in English 1530 GMT 11 Jul 84 BK] A TV transmitter was commissioned today at Cuddapah, Andhra Pradesh. It will have a range of 25-km and will serve a population of about 3 lakh. [Summary] [Delhi Domestic Service in English 1530 GMT 12 Jul 84 BK] A TV transmitter was commissioned today at Shahjehanpur, Uttar Pradesh. It will cover a population of nearly 8 lakhs. Some of the towns which will come within its range are Shahganj and Rastra. It is the 60th TV transmitter in the country. [Text] [Delhi Domestic Service in English 1230 GMT 13 Jul 84 BK] The 61st TV transmitter in the country was commissioned today at Gaya in Bihar. It will cover 2,000 square kilometers and a population of over 11 lakhs. [Excerpt] [Delhi Domestic Service in English 1230 GMT 14 Jul 84 BK] A TV transmitter was commissioned in Karimnagar, Andhra Pradesh, today. It will have a range of 2,000 square kilometers and will cover a population of more than 4 lakhs. [Summary] [Delhi General Overseas Service in English 1330 GMT 15 Jul 84 BK]

66th TV TRANSMITTER--A TV transmitter was commissioned today at Akola in Maharashtra. It is the 66th TV transmitter in the country. It will have a range of 2,000 square kilometers and will cover a population of about 5 lakh. [Text] [Delhi Domestic Service in English 1530 GMT 19 Jul 84 BK]

CSO: 5500/4738

## BRIEFS

NEW 500 KW TRANSMITTER SITE--The minister of information and broadcasting services, Mr Cosmas Chibanda, has expressed satisfaction at the ground work for the installation of a 500-kilowatt mediumwave transmitter for the Zambia Broadcasting Services [ZBS]. The Minister, who this morning toured the (Twin Farms) transmitters in the company of ZBS acting director general, Rev Roger Ngombe, and other senior ministry officials, was told work is expected to be completed by December this year. Once operational, it is expected that reception will improve throughout the country, especially at night. Later, Rev Ngombe said 2 engineers and 4 technicians have just completed a 3-month course in France, where the transmitter was bought. He said, however, that they were expected to continue on-the-job training after the operational phase. [Text] [MB171948 Lusaka Domestic Service in English 1800 GMT 17 Jul 84]

CSO: 5500/92

## NONALIGNED NATIONS SET UP NEWS AGENCY POOL

Moscow APN DAILY REVIEW in English 16 May 84 pp 1-2

[Article: "For a New Information Order"]

[Text] A pool of the news agencies of non-aligned countries was officially instituted in New Delhi on July 17, 1976, Veniamin Shurygin writes in PRAVDA answering to a question by a reader of the newspaper about cooperation between the news agencies of non-aligned countries. The principal aim of the pool is to promote a free and balanced flow of information on events in the non-aligned and other developing countries and in the territories the peoples of which still struggle for national liberation. At present the pool includes 87 participants.

The seventh non-aligned summit which was held in March last year expressed satisfaction with the progress achieved by the news agencies' pool. In the past eight years the volume of its information grew both quantitatively and by the scope of topics. Nowadays the pool exercises influence on the activities of other international and regional systems of news exchange, the newspaper goes on.

At the same time, as was pointed out at an international seminar of the pool participants in New Delhi in April this year, there are a number of drawbacks and difficulties in the pool's work. Those include a shortage of modern equipment and means of communication, high international communications tariffs, and a shortage of experienced personnel. Recommendations drawn up by the seminar point out the need to further increase the volume of transmitted information and to raise its quality. Special attention is drawn to the need to cover international events more widely and to exchange all-round information about life in the non-aligned countries.

The 38th session of the UN General Assembly in its resolutions pointed out the need for cooperation between all states in the establishment of a new, fair order in the field of information. The resolutions expressed full support for the young independent states' efforts aimed at combatting the information dominance of imperialism. There is no doubt that the activities of the pool of the news agencies of non-aligned countries make their contribution to this lofty cause, Veniamin Shurygin emphasises.

(PRAVDA, May 14. Summary.)

CSO: 5500/1025

CONTROVERSY OVER LUXEMBOURG GDL SYSTEM OUTLINED

Role of TV-Sat, TDF-1

Frankfurt/Main FRANKFURTER ZEITUNG/BLICK DURCH DIE WIRTSCHAFT in German  
7 Jun 84 p 7

[Article by Michael Wett: "The GDL System Is Expected To Make Television Channels Cheaper: Direct Reception Through Parabolic Antennas/GDL Coronet Introduced in Luxembourg/15 Channels"]

[Text] Frankfurt. In the beginning of June 1984 investors and other persons interested in the GDL/Coronet satellite project met in Luxembourg. On 25 May the Luxembourg Government granted the concession for this project to the Luxembourg satellite company SLS (participants: Luxembourg banks and an American promoter). The programs broadcast over 16 channels by the GDL satellite system--legally a communications satellite with the technical features of a radio satellite--are said to be receivable throughout all western Europe in a region inhabited by about 200 million Europeans, using 90-cm individual antennas and also by means of cable networks and community antennas. On 6 June the minister presidents of the FRG states, bearing authority in radio affairs, assembled in order to make a decision regarding the distribution of 13 out of a total of 15 satellite channels throughout the FRG.

Included are six channels of the telecommunications satellite Intelsat V (Intelsat is an association of telecommunications administrators in all continents which was founded in 1964 by the United States and 10 other countries). Also included are five channels of "Kopernikus," the first communications satellite (DFS--German Telecommunications System) of the FRG, and two channels of the FRG radio satellite "TV-Sat." Thus far these heads of the states have only decided on two channels of the European communications satellite ECS which are used by the ZDF (east beam) and by private program organizers (west beam).

Because now the realization of the GDL/Coronet project, so long coveted by the European telecommunications administrators, can no longer be held back. Those who are potentially interested in this project are Bertelsmann, Philips, Teleclub (Switzerland), Euro-TV (Holland) and a number of others. There is certainly plenty of reason for the Eutelsat Company, an association of 20 telecommunications administrators in European countries founded in Paris in 1978, to make an assault against GDL/Coronet.

For one thing: although the GDL system involves only a "medium-strength" satellite and although it will be equipped with 16 channels (active retransmitters) and works with frequencies which are also used by communications satellites having weaker transmission energy, nevertheless it will permit direct reception with 90-cm parabolic antennas. The GDL system thus combines advantages of both types of satellite: those of the communications satellite which requires only a low transmission power (around 20 to 40 watts) combined with the advantages of the directly radiating radio satellites (high transmission power: about 260 watts) whose broadcast radio and television programs will be receivable directly by anyone. According to rumor the 16 channels available reduce the cost per channel to a third; against this the German and the French radio satellite of the same design, the TV-Sat (FRG) with only three operating channels, and the TDF (France) also with only three channels could not compete.

Secondly, Eutelsat perceives in the GDL/Coronet project a sort of Trojan horse for American interests in Europe: the promoter and joint owner of the project (45 percent in the Luxembourg satellite company SLS) is the American C. T. Whitehead. In this connection it is important to note that at this present point in time European technology for medium-power satellites, of which the GDL system is one, is lagging behind the United States.

The various interrelationships may be better understood if one examines more closely the currently planned and already realized satellite projects. Basically one distinguishes communications satellites such as Intelsat, ECS, Kopernikus/(DFS) and Telecom from radio satellites such as Unisat, TV-Sat and TDF.

Radio satellites, also called direct broadcasting satellites (DBS), are technically more expensive than communications satellites and require a relatively high transmission power (about 260 watts). The radio and television programs broadcast via radio satellites can be directly received essentially by everyone within the transmission area by using individual antenna installations of, for example, 90-cm diameter or better of 180-cm diameter. The operation of radio satellites presupposes the use of efficient solar generators. The rental for a radio satellite channel is more expensive than for a communications satellite channel because in the radio satellite the active retransmitters (channels) require more engineering outlay.

In the fall of 1985 it is expected that two satellites of the same design, TV-Sat 1 and TDF 1, will be placed in orbit as the first European radio satellites. While the German satellite TV-Sat 1 is a test satellite and is intended for 2 years of experimental operation the French radio satellite TDF 1 is to be put in operation immediately. Both satellites will be equipped with five channels each, but because of current performance limitations on solar generators only three channels can be used (the remaining channels are provided as a reserve). The TV-Sat could be used for digital stereo audible programs (first channel) as well as for television programs both for public use (second channel) and also for private use (third channel). Decisions have still to be made regarding the final channel occupancy of the FRG TV-Sat--as also of the French TDF.

Whether after the 2 years of testing with the TV-Sat 1 there will be a commencement of the operational phase of the TV-Sat 2 (five operating channels) and the start of the TDF 2 (France) 1987 (five channels) is questionable. Because for TV-Sat and also for TDF the cost covering use fees would probably be about 30 million marks per year, which amounts to 10 million marks per each channel. On the other hand it is claimed that the GDL/Coronet company will offer a channel for a third of that price.

Thus the great interest in the GDL/Coronet project on the part of potential program suppliers is understandable and it appears to be entirely possible that the German-language RTL-plus-program planned by Radio Tele Luxembourg (RTL), in which Bertelsmann is participating at 40 percent, will not as planned be broadcast over the French TDF satellite but via the Luxembourg GDL satellite system.

The question arises as to how the GDL/Coronet company can offer the communications channel at a substantially cheaper price? Is the technological design of its satellite system so superior? Legally the GDL system is a telecommunications satellite; technically it possesses the characteristics of a radio satellite. Thus it combines advantages of the communications satellite (low transmission power) with those of the radio satellite (direct broadcasting and hence reception by everybody).

#### Channels, Costs Involved

Frankfurt/Main FRANKFURTER ZEITUNG/BLICK DURCH DIE WIRTSCHAFT in German  
8 Jun 84 p 7

[Article by Michael Wett: "The Satellite Costs Can Be Distributed Over 16 Channels: The GDL System Is Expected To Make Television Channels Cheaper"]

[Text] With regard to the technological design of the GDL system: GDL is a medium-power satellite; it uses the frequencies of the communications satellites (which get along with weaker transmission energy). The GDL satellite system differs in this respect from high-power satellites which employ the frequencies of directly broadcasting radio satellites. The frequencies for radio satellites were established in 1977 in Geneva. Each European country received five channels. Since the entire cost of satellite manufacture and launching must be distributed over this small number of channels the cost per channel is correspondingly high.

On the other hand the GDL satellite system is expected to use the frequencies of the SFS (Service Fixe Par Satellite) and hence is not subject to the limitation to five channels; it is designed for 16 channels. That is probably the nub of the matter: the satellite manufacturing and launching costs can be distributed over 16 channels and thus lower the cost per communication channel to about one-third.

But how is it technically possible to feed 16 active retransmitters with even that much energy and still make it possible for the broadcast programs to be received everywhere in western Europe with 90-cm individual antennas? Do the

operators of the GDL/Coronet project have access to a new generation of solar generators? That European technology in medium-power satellites is behind American technology may hardly be disputed. But in the area of receiving equipment European industry is not essentially behind. Is it possible that special know-how in medium-power satellites, the details of which are secret, accounts for the entire superiority of the GDL system?

It is still not yet possible to answer that question. The functioning and the reliability of the new satellite technology is said to have been verified by independent experts who were present at the various tests conducted in Canada and in the United States. This appears to be supported by both the number and the quality of the interested parties.

There remains some skepticism: Does the energy generated by (possibly technologically superior) solar generators suffice to broadcast programs over 16 channels which can actually be received in Europe with 90-cm individual antennas (price of the individual receiving equipment, consisting of antenna, converter and installation is at the present time about 2,000 marks)? Or for direct reception are the essentially more expensive 180-cm individual antennas necessary? Moreover, as long as individual antennas cannot be used in sufficient number for direct reception the programs broadcast by GDL can also be received through cable networks and through community antennas.

The commercial design of the GDL/Coronet project envisages its income as coming from the provision of satellite channels for various program companies. Thus it differs from those program, radio and television companies which get their income from advertising. The GDL satellite system can broadcast programs which are financed through advertising and can also broadcast programs without advertising which in other words are paid for by contributions made by the television viewers (pay TV). In successfully obtaining the concession the GDL/Coronet project is filling up a gap which arose in Luxembourg: the Compagnie Luxembourgeoise De Telediffusion (CLT) has given up the Luxsat project--a purely Luxembourg satellite. For broadcasting its television programs the CLT intends to use the French TDF satellite. This decision led to the GDL/Coronet project for which the Luxembourg Government granted the concession to the SLS company on 25 May 1984.

International communications satellites: Commercial communications satellites of the Intelsat type have been used internationally since 1965. The international network of the Intelsat organization with at the present time over 100 member countries is operated with 15 commercial communications satellites for international television transmissions and telephone links. Intelsat I was capable of transmitting only one television program or 240 telephone conversations simultaneously from continent to continent. Intelsat VI which is to be put into operation in 1986 will be able to simultaneously transmit four television programs and 33,000 telephone conversations.

The "Kopernicus" communications satellite (officially: DFS = Deutsches Fernmeldesystem) of the German Postal System and Telecom of the French Postal System are used on a strictly national basis. "Kopernicus" is intended to supplement the existing terrestrial cable and microwave networks and in addition

to the distribution of all five ARD III television programs it is expected to be used for the construction of a wide-area surface network for new communications services (data and text communication, facsimile, video conference). In addition it is expected to be used for digital telephone and data links. The DFS will consist of two operational satellites and two replacement satellites, developed by a German consortium of companies and placed in a geostationary orbit in 1987 and 1988 by means of Ariane rockets.

Regionally: The European communications satellite system ECS is being constructed by the Eutelsat organization, in which the FRG participates at 10.8 percent, regionally for intra-European telephone and data traffic as well as for the distribution of television programs. The ECS will be a constituent of the public telecommunications network and for reasons of security will consist of one operating satellite and one replacement satellite. The first communications satellite (ECS-F1) has already been in use since 1983. ECS-F2 is expected to be put in orbit in July 1984 by the powerful launching rocket Ariane 3. These two flight models are the first step in the ECS program. In 1985 there will be added to the two German ECS channels an additional channel (ECS-F3) and at least six via the Intelsat system.

The ECS-F1 is equipped with 12 transponders, all having the same design (transponders are the communications engineering devices used for preparing and converting the signals). Each transponder will have a band width of 80 MHz and an output power of 20 watts. Nine of them may be operated simultaneously. Through each transponder it is possible to simultaneously transmit about 3,000 telephone conversations or one television program. The ECS-F2 has 14 transponders with transmission and reception antennas for the following services: fast data transmission, office communication, video conferences (satellite multiservices (SMS)). The transmission in the upward direction is in the 14-GHz range while in the downward direction it is in the 11-GHz range. The ECS receives the signals from the transmitting earth-based radio installation in Usingen/Taunus (19-meter dish diameter) through one antenna and transmits it through four antennas (one for coverage all over Europe and one each additional for smaller regions). The signals are received by earth-based radio reception stations having parabolic antennas which are 3 to 5 meters in size and then fed into cable television equipment. Direct reception by everybody is not possible. In the FRG at the present time there exist two receiving earth-based radio stations of this type: the cable pilot project facilities in Ludwigsburg and Munich. The German Postal System now wants to erect seven more ECS earth-based radio receiving stations in Berlin, Kiel, Hanover, Hagen, Meschede, Stuttgart and Weiden (Oberpfalz). The four television programs broadcast by ECS-F1 will then be fed into the cable networks of these cities. An additional 64 earth-based radio receiving stations are planned.

The ECS fees are understood to be about 6 million marks per channel. But let us recall once more: in the GDL/Coronet project which is designed for direct reception fees are being mentioned which amount to around 3 or 4 million marks per channel.

8008

CSO: 5500/2725

MOBIRA FIRM FINDS SUCCESS IN EXPORTS OF MOBILE PHONES TO U.S.

Helsinki HELSINGIN SANOMAT in Finnish 5 Jun 84 p 25

[Article by Heikki Arola: "Mobira's Black Box Beeps to America"]

[Text] A black beeping box has created an almost 100-million markka trade -- by chance -- in the United States for the Mobira Corporation. This enterprise, which has taken off like a rocket, intends to take advantage of this chance in order to drum up additional markets. Mobira is insolently breaking into the markets of the large manufacturers and believes it will persevere.

The Mobira Corporation's main plant is located in Salo in the shadow of the Salora Corporation's plant in Halikon Valley. The wits have christened this place "Halikon Valley" after the famous electronics valley of "Silicon Valley".

Previously, Mobira was owned by Salora, now both firms are sister corporations in the Nokia concern. But it will not be very many years before Mobira reaches the status of its former owner. Mobira's Managing Director Jorma Nieminen considers that at this rate sales will exceed the billion-markka mark in 1988, and the possibilities may be even greater. Salora's sales turnover was 737 million last year.

#### Surprise Transaction

Managing Director Nieminen smilingly fingers Mobira's new success article, a portable pocket-size call finder [paging unit], which was the basis of a transaction concluded last week with an American firm.

From the outside the box does not appear to be anything out of the ordinary, but Nieminen boasts without any reservations that this is the best paging unit in the world at this time. And there is good reason for this boast since it is doubtful that an American firm would have otherwise selected this particular unit.

According to Nieminen, this piece of equipment is the "first second-generation product" in this field, in which competition is very stiff.

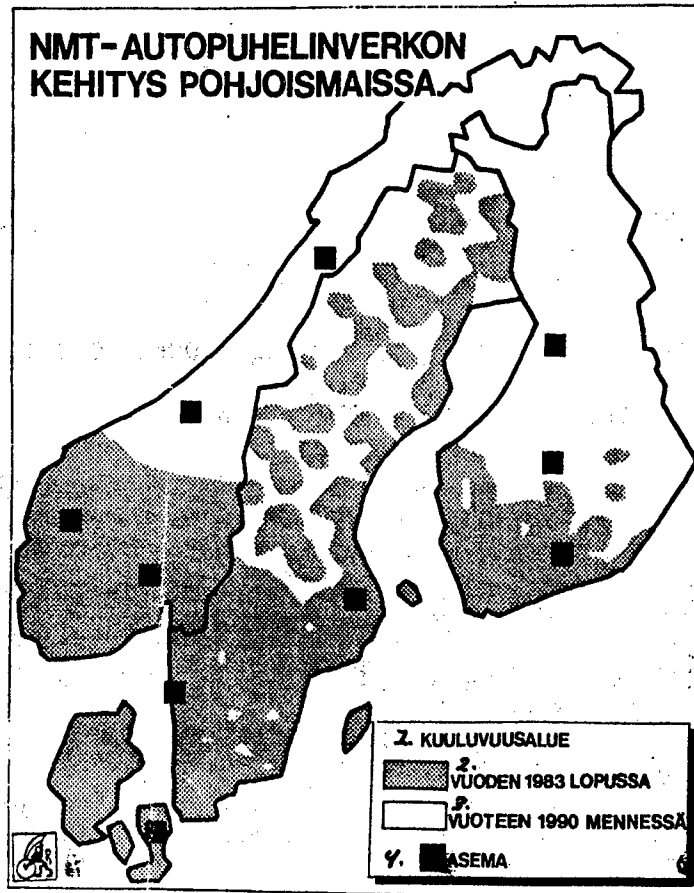

Development of NMT Mobile Phone Network in Nordic Countries

Key:

- |                      |            |
|----------------------|------------|
| 1. Area of reception | 3. By 1990 |
| 2. By end of 1983    | 4. Station |

The fact that this transaction materialized was, indeed, a surprise even to the manufacturers of the unit. At one time consideration was even given to halting product development, but in the final count there was no desire to give up the 10-million markka markets in Sweden.

Now Mobira is blessing the day that the decision was made to continue the project. Stated in economic terms, the U.S. transaction opened up a surprising crack in the market for Mobira, and this crack could yet expand into a chasm since after the United States Mobira is awaiting the kind of decision the Western European countries will make in their personal paging system.

Only in Sweden

Mobira's unit is intended for a nationwide paging system, which so far can only be found in Sweden. There already 40,000 people carry a small black box in their pocket, a large portion of them manufactured by Mobira.

The figures being contemplated in the United States are of a completely different category. The network will include 200 of the largest cities and hundreds of thousands of people. Thus it is no wonder that there are itchy fingers in Salo.

The paging system uses the television as well as the radio networks. The person doing the paging dials his own number and the number of the unit belonging to the individual being paged into a telephone company computer, which transfers the number to the computer. The recipient's unit beeps and the display screen shows the number which should be called.

In Finland there is no use for Mobira's unit since the Finnish Broadcasting System did not want to provide its network for paging purposes. The Postal and Telecommunications Administration will soon develop its own network for this purpose. Mobira is deliberating whether it will begin development of a suitable unit or whether to surrender the field voluntarily to foreign competitors.

#### Only a By-Product

Mobira's present and future growth is not, however, based on this paging unit, which is only a by-product. Its main business pertains to mobile telephones, which, in fact, are competing with the paging unit and before long will supplant it.

The mobile phone will be reduced in size until it will be perhaps the size of a checkbook in 10--20 years, and it will no longer have to be confined just to an automobile, but will be carried in one's pocket. And compared to the paging unit it is superior since it is bidirectional.

Mobira is basing its growth on the mobile phone and on the fact that the mobile phone markets are now opening up in the world. For the time being the Nordic countries have been ahead of the rest of the world since the world's only unified network is here, but others are now beginning to become seriously involved.

#### Several Systems

The NMT-markets (Nordic Mobile Telephone) of the Nordic countries are exceeding the 100,000 subscriber mark, but when the United States begins developing this field this year, this number will be quickly surpassed.

The markets are further confused by the fact that several different types of telephone systems are being developed so that maintaining communications between them will be impossible.

In addition to the NMT system of the Nordic countries, the AMPS-system is being developed in the United States. In December England will start up its TACS, which is related to the U.S. system, but operates on a different set of channels. West Germany and France are considering their own procedures, and a fifth system will be Japan's NTT, which is still in the initial stage of development.

The reason for this state of confusion is the absence of an international agreement. However, the fact that Europe's telecommunications administrations recently agreed on a new audibility figure on which all European systems will be able to operate, will be of help over the long term.

Managing Director Nieminen does not consider it impossible that within 10--20 years there will be one unified mobile telephone network in Europe covering the whole continent.

#### Indifference

However, it is quite a matter of indifference to Mobira as a business enterprise as to how many systems there will be in the world. The products of even the smallest changes in this unit will be marketable for whatever system.

And this is what has happened. Along with Ericsson Mobira has kept pace with the others in the Nordic countries. Mobira is building a plant in the Far East with the American Tandy Corporation in order to gain a foothold in the U.S. markets. A transaction was concluded with England at the end of last year and efforts to obtain a French and West German decision are in the initial stage.

Mobira will not be able to sell the telephone made in the Far East with the Tandy Corporation under its own name in the United States, but this restriction does not apply to units manufactured in Finland, and Mobira intends to enter the markets on the other side of the Atlantic under its own name also, a suitable distribution network must be found.

#### Competitive Race

Nieminen believes that after a couple years the competitive race in the United States will be resolved to the benefit of a few manufacturers. In spite of the large and well-known competitors, he believes in Mobira's possibilities since the competition in the Nordic countries was already of a worldwide scale. The mobile telephone fever is now at its height in U.S. economic circles. Indeed, Wall Street does not talk about "mobile phones", but about "cellular phones", a term which Mobira's people would like to see used even in Finland. It is, indeed, a question of a telephone network operating on a cell principle, which in itself has nothing to do with an automobile.

In the United States the Mobira people are asked why the cellular phone is more developed and prevalent in the Nordic countries. Nieminen says that he gives the credit to the telecommunications systems of these countries, which understood the benefits of a unified and integrated network in the beginning of the 1970's already. Later the countries included those firms interested in this matter in the development work. "Cooperation has been splendid," states Nieminen.

#### New Dimension

The quick success of mobile phones in the Nordic area was a total surprise to the manufacturers. Subscribers to the system came more quickly than expected.

In Mobira they began to ask what is the essence of this. They came to the conclusion that a new product had been found which brought a totally new dimension to people's lives. In the same manner that the automobile in its time gave people a new mobility, the mobile phone brought a new availability, decided the people in Mobira.

"There are people who want to be available at all times, and we believe that in the future it will be just as difficult for organizations to manage without mobile phones as it is now impossible to manage without traditional phones.

"This is the reason why we strongly believe in this business," explains Nieminen.

#### Army Was Impetus

Mobira can thank the Army for its existence. In 1963 the General Staff wanted to order so-called company radios. The appropriations were not obtained, but four radio plants were built in the country, Salora, Nokia, Televa, and AGA.

In 1975 Salora and Nokia began to seek cooperation when foreign competition began to appear. In 1979 Salora and Nokia jointly established Mobira. In 1982, Salora sold its shares to Nokia and last year Mobira purchased the Telenokia Radio Telephone Plant, the former Televa, from the parent company in Espoo.

According to Managing Director Nieminen, the primary problem now is to maintain control over the operation. The decisive year will next be year when the sales turnover will increase to 500 million. "If we do well in America, I believe that then everything will become easier."

In Nieminen's opinion Nokia's entry as a supporter was inevitable from the point of view of the firm's expansion: "Without Nokia this kind of success would not have been possible and the guarantees would have run out in mid-stream."

Nokia's shareholding enterprise, Micronas, which manufactures semiconductor components, is also indispensable to Mobira. For the time being, the planning will take place in Finland and the manufacture in California, but in 1986 even the manufacturing operation should be transferred in its entirety to Finland.

10576

CSO: 5500/2709

## TELESTE DEVELOPING THIRD GENERATION OF SATELLITE ANTENNAS

Helsinki HUFVUDSTADSBLADET in Swedish 30 Jun 84 p 11

[Article by Birgitta Jernvall Ingman: "Tailwind for Teleste; Satellites Give Growth"]

[Text] "Scandinavia's most attractive high-technology company!"

Managing director Erkki Backman displays no false modesty when talking about the company he heads, Teleste Oy in Turku.

Rightly so, because it is in the midst of a strong growth period; the staff is increasing at the average rate of about 10 a month and turnover this year is expected to rise to 100 million Finnish marks. The primary source of this growth is television satellites.

The company manufactures cable television systems including satellite receivers. This takes place within the Teleste Antenn division, which is responsible for 40 percent of the company's turnover and which in the next few years is expected to grow by nearly 100 percent a year. Forty percent is also contributed now by Teleste Ljud, which produces transmission systems for public areas such as hospitals, hotels and large ferries. The company's third leg is Auditek, which manufactures language laboratories.

Teleste was founded 30 years ago by Olavi Ahonen and Pekka Valkama. To begin with, the company manufactured radio antennas, among other things. Then came the advance of television and new antennas were needed, and new amplifiers as well, since there were few transmitters.

In 1970 the development company Sponsor entered as joint owner, in order gradually to take over the entire amount of outstanding stock.

### In the Lead

Seven years later Teleste decided to begin development of satellite receivers. At that time it was said that the satellites would not come until 1986, but the work was initiated and the first prototype completed in 1981. This meant maximum luck for the company, because the television satellites also appeared in 1981 and Teleste alone in all of Europe was capable of manufacturing receivers for them.

"This put us in the lead," Backman says and adds that the company has been able to retain this lead and is still the leading firm in Europe.

Teleste is the only company in Europe producing parabolic mirrors from fiberglass, or, rather, its subcontractor Fiskars is making them.

The Finns had learned how to make large fiberglass boats, which requires maximum accuracy, just as do satellite antennas, Backman says. The problem was only how to make the fiberglass electrically conducting. After a few visits to the United States, among other places, this was accomplished--which is now Teleste's well-kept secret.

Another Teleste specialty is that they have learned how to use coaxial cable, delivered by Nokia, for the transmission of information.

The telephone network is now often used for transmission, but its bandwidth is only 5 MHz and it cannot accommodate a television channel requiring 10 MHz. A 1,000-MHz coaxial cable, on the other hand, can contain 100 television channels.

"We want to build large-capacity information transmission networks," Backman states.

#### Export Growing

Teleste's exports represent about 30 percent of the turnover and is constantly increasing. Antenn exports approximately half of its production and Auditek about 70 percent, while Ljud's export is quite small.

Who are your biggest competitors?

"The West Germans have been difficult. But now we officially have 90 percent and in practice almost 100 percent of the cable television market in Finland, 60-70 percent in Sweden and 40 percent in Norway." (For experimental reasons a cable television network is maintained for 500 households near the factory.)

"As for satellite receivers, we have about half of the European market. Our worst competitors are the Americans, who fortunately are quite far away."

Why is it that the Finns have succeeded so well in electronics?

"The Finns are stubborn, have something like a guerrilla soldier quality and are not stupid. Software developers are artists, project-oriented and not tied to one place of work. The question is only how to get these people to cooperate and stay. The head of personnel has a key position here; it is vital for him to choose people who are emotionally compatible."

## Harmonious Surroundings

"In the high tech sector it is also not possible to put everyone under the same roof. Teleste has its production in five places," Backman says and stresses the importance of harmonious and beautiful surroundings.

Teleste now has about 420 employees, half of whom are salaried. Of the salaried employees, nearly half are at least graduate engineers.

The cooperation with colleges and institutes is intimate and "a large bundle of brains is needed," as Backman puts it.

## Foreign Engineers?

But he is not satisfied with the training at our institutions of higher learning. Ten years ago an incorrect evaluation was made, he says. Too few people are now being trained for the industry and, furthermore, the institutions lack the advanced--and expensive--equipment which teaching would require. If nothing is done, the day is not far away when we may have to begin importing foreign engineers, Backman maintains.

But so far the company has not had any problems getting labor, despite the fact that it does not pay very well, according to the managing director. Contributing factors are the company's profile and the location of the factories.

One of the men behind Teleste's success is graduate engineer Henry Gylen, who designs microwave units and antennas for satellite reception. He lives in Sarkisalo and has an engineering degree from the Helsinki Institute of Technology. He came to Teleste 3 years ago, having met the head of the division in the army.

## Women Make Printed Circuit Boards

Hannu Eromaki works as supervisor at the factory in Nousis, where network equipment is manufactured. He is a technician and came to the company 2 years ago, directly out of school. Hannu lives in Nousis and says that he likes it there.

"Best is the short distance to work. Furthermore, it is an interesting branch of industry, developing and a little different."

Maarit Sillanpaa also lives in Nousis. She is a cosmetologist by profession, but now she sits and assembles circuit boards from components.

She also regards the short commute as a major advantage.

Teleste offers work to both men and women. And Backman emphasizes with satisfaction that in the company there is no barrier between office and factory. Working on the factory side does not imply lower status.

But the circuit boards are manufactured solely by women.

"It wouldn't work out if men were to make them. After 2 hours they would start thinking about whether it couldn't be done in a different way instead."

Time to Sell or Buy More?

Teleste is wholly owned by the development company Sponsor Oy. The purpose of such a company is to help enterprises develop and later to withdraw, when everything functions. Is it time to sell Teleste? This question is directed at Hannes Kulvik, managing director of Sponsor.

"Previously, the way we did it was to build up company groups and gradually sell them. We had no other alternatives when we needed money. Now that we are listed on the stock exchange we have other opportunities for raising stock capital and are not forced to sell. We have changed our philosophy and are letting the Sponsor group grow. The Teleste group will also be allowed to grow."

Are you aiming toward acquiring companies?

"We are, but the time for that is open. It might take 3 months or 3 years."

At home or abroad?

"We are interested in companies both in Finland and abroad. For example, right now we are looking at some companies in Europe. Most interesting are those which can offer synergistic effects, companies whose activity is close to Teleste's."

On the other hand, as far as Sponsor is concerned the Aspo chapter is closed, according to Kulvik.

11949

CSO: 5500/2733

## TELECOMMUNICATIONS AGENCY TO SPEND RECORD AMOUNT IN 1984-85

Stockholm SVENSKA DAGBLADET in Swedish 8 Jun 84 p 27

/Article by Bo Ostlund/

/Text/ The Swedish National Telecommunications Administration will carry out its biggest investment program ever in the fiscal year 1984-1985, beginning on the 1st of July. At the same time, the National Telecommunications Administration is the first state administration to enter the credit market on its own since Parliament granted the administration financial independence.

The record investments will amount to 6 billion kronor and were set by the National Telecommunications Board on Thursday. However, this does not signify higher prices for telephone calls. The National Telecommunications Administration explained at a press conference on Thursday that the main part of the investments will be furnished by depreciation allowances and their own profit sources. According to the prognosis, the turnover for 1983-1984 will be 2.5 billion kronor after depreciation allowances.

The new money will mainly be invested in expanding the telephone network. All told, routine telephone assistance is the most requested service even if other telephone sectors such as computer and data processing as well as NMT [Nordic mobile telephone] are currently growing at the fastest rate. The investments mean that 300 new people will be employed next year.

Earlier this year Parliament decided that the National Telecommunications Administration would receive greater responsibility for financing beginning in the next fiscal year. It was previously the case that every penny had to be approved by Parliament. The change means that the administration may borrow on the public credit market and from firms and financial institutions. Loan transactions will be managed by the National Telecommunications Administration's own organ, Teleinvest AB.

Teleinvest will sell so-called telecertificates or promissory notes and telecommunications bonds for 4 billion Swedish kronor. The telecommunications bonds will be issued at the minimum denomination value of 1 million Swedish kronor.