

R  
302091

JPRS-TTP-85-019

1 August 1985

Worldwide Report

TELECOMMUNICATIONS POLICY,  
RESEARCH, AND DEVELOPMENT

19980828 114

DTIC QUALITY INSPECTED 4

**FBIS** FOREIGN BROADCAST INFORMATION SERVICE

REPRODUCED BY  
NATIONAL TECHNICAL  
INFORMATION SERVICE  
U.S. DEPARTMENT OF COMMERCE  
SPRINGFIELD, VA. 22161

2  
137  
A07

## NOTE

JPRS publications contain information primarily from foreign newspapers, periodicals and books, but also from news agency transmissions and broadcasts. Materials from foreign-language sources are translated; those from English-language sources are transcribed or reprinted, with the original phrasing and other characteristics retained.

Headlines, editorial reports, and material enclosed in brackets [ ] are supplied by JPRS. Processing indicators such as [Text] or [Excerpt] in the first line of each item, or following the last line of a brief, indicate how the original information was processed. Where no processing indicator is given, the information was summarized or extracted.

Unfamiliar names rendered phonetically or transliterated are enclosed in parentheses. Words or names preceded by a question mark and enclosed in parentheses were not clear in the original but have been supplied as appropriate in context. Other unattributed parenthetical notes within the body of an item originate with the source. Times within items are as given by source.

The contents of this publication in no way represent the policies, views or attitudes of the U.S. Government.

## PROCUREMENT OF PUBLICATIONS

JPRS publications may be ordered from the National Technical Information Service, Springfield, Virginia 22161. In ordering, it is recommended that the JPRS number, title, date and author, if applicable, of publication be cited.

Current JPRS publications are announced in Government Reports Announcements issued semi-monthly by the National Technical Information Service, and are listed in the Monthly Catalog of U.S. Government Publications issued by the Superintendent of Documents, U.S. Government Printing Office, Washington, D.C. 20402.

Correspondence pertaining to matters other than procurement may be addressed to Joint Publications Research Service, 1000 North Glebe Road, Arlington, Virginia 22201.

1 August 1985

WORLDWIDE REPORT  
TELECOMMUNICATIONS POLICY, RESEARCH AND DEVELOPMENT

CONTENTS

ASIA

AUSTRALIA

Reportage on Progress in National Satellite Development  
(Sydney THE AUSTRALIAN, 20, 25-26 May 85; Melbourne  
Overseas Service, 24 Jun 85) ..... 1

Controversy Continues Over Structure, by Helen Meredith 1  
Contract Combines Resources, by Helen Meredith 2  
Military Use Considered, by Ross Peake 2  
TV Network Negotiations Continue, by Errol Simper 3  
Loans for Satellites Signed 3

CAMBODIA

Briefs  
PRK Media Delegation in Moscow 4

HONG KONG

Preparatory Committee To Form Media Council Set Up  
(Hong Kong SOUTH CHINA MORNING POST, 10 Jun 85) ..... 5

Powers Bill Said To Endanger Flow of Information  
(Agnes Chen; Hong Kong SOUTH CHINA MORNING POST, 12 Jun 85) 6

Newsman Calls for Freedom of Press in Basic Law  
(Patricia Tse; Hong Kong SOUTH CHINA MORNING POST,  
17 Jun 85) ..... 7

'Breakthrough' Modem Released  
(Hong Kong HONGKONG STANDARD, 13 Jun 85) ..... 8

Briefs		
	Minicomputer Connection Approved	9
	Datacraft's Network Processor	9
INDONESIA		
	Minister on Launching of Palapa B-3 Satellite (Jakarta Domestic Service, 13 Jul 85) .....	10
Briefs		
	Palapa A-1 Sent Into Distant Orbit	11
JAPAN		
	No Progress in Telecommunications Talks With U.S. (Tokyo KYODO, 7 Jun 85) .....	12
	Report Favors Asian Satellite Telecommunications Network (Tokyo KYODO, 11 Jun 85) .....	13
MALAYSIA		
	Fujitsu Wins Telecommunications Contract (Vong Nyam Ming; Kuala Lumpur BUSINESS TIMES, 3 Jun 85) ...	14
PEOPLE'S REPUBLIC OF CHINA		
	Hainan Imports Italian Microwave Equipment for Radio-TV Use (Hainan Island Service, 30 May 85) .....	15
	Merits of Fiber-Optic Communications Discussed (Xiao Xizhang; Shanghai XIANDAI TONGXIN, No 1, 8 Jan 85)	16
	Method of Measuring Omnidirectional Satellite Antenna Tested (Zhang Jinbiao; Beijing DIANZI KEXUE XUEKAN, No 6, Nov 84)	22
	Encryption Method for Images Described (Zhang Pingsheng, Bi Houjie; Beijing TONGXIN XUEBAO, No 3, Jul 84) .....	34
Briefs		
	Largest Telecommunications Project Completed	44
	Telecommunications Committees Set Up	44
	First Mobile Field Satellite Station Developed	44
	New Broadcasting Station in Liaoning	45
SOUTH KOREA		
	High Tech Stride in Communications Reported (Tokyo NYU MEDIA, No 2, Feb 85) .....	46

THAILAND

Briefs  
Mobile Phone System From Ericsson 52

CANADA

Canadian Firm Providing Cable TV Service in Amazon  
(Toronto THE GLOBE AND MAIL, 7 Jun 85) ..... 53

EAST EUROPE

GERMAN DEMOCRATIC REPUBLIC

GDR Opposes Planned Commercial Radio Expansion  
(Hamburg DER SPIEGEL, 10 Jun 85) ..... 54

HUNGARY

Construction of Cross-Bar Telephone Exchange Described  
(Budapest VASARNAPI HIREK, 2 Jun 85) ..... 55

LATIN AMERICA

INTER-AMERICAN AFFAIRS

Space Conference Issues Satellite Placement Recommendations  
(Bogota EL TIEMPO, 1 Jun 85) ..... 58

BAHAMAS

Nation Becomes 10th Member of INTELSAT Agreement  
(Nassau THE TRIBUNE, 17 Jun 85) ..... 60

CUBA

Briefs  
Television Modernization Plans 61

JAMAICA

Briefs  
Data Satellite 62

NEAR EAST/SOUTH ASIA

AFGHANISTAN

Faizabad TV Station in Operation (Kabul KABUL NEW TIMES, 15 Jun 85) .....	63
--	----

ALGERIA

Briefs Radio, TV Accord With Iraq	64
--------------------------------------	----

BANGLADESH

Papers Report Telecom Situation, Future Plans (Dhaka, various sources, various dates) .....	65
Third Five-Year Plan Aims	65
More Details Given	67
Editorial Examines Prospects	68

EGYPT

Briefs Plan To Launch Satellite	70
------------------------------------	----

INDIA

Broadcasting Minister on Liberalization Policy (V. N. Gadgil; Calcutta THE TELEGRAPH, 16 Jun 85) .....	71
Indian TV To Experiment With Teletext Service (Madras THE HINDU, 12 Jun 85) .....	74
Ministry Seeks To Equip Relay Centers for State Capitals (Calcutta THE TELEGRAPH, 18 Jun 85) .....	75
Hindu Cables Expansion Plans Detailed (Calcutta THE TELEGRAPH, 10 Jun 85) .....	76
Joint Venture To Manufacture Telecom Equipment (Calcutta THE STATESMAN, 4 Jun 85) .....	77

PAKISTAN

Briefs 'Advanced Stage' Satellite Plans	78
--	----

SUB-SAHARAN AFRICA

INTER-AFRICAN AFFAIRS

Briefs  
     PANA Appointments 79

DJIBOUTI

Satellite Earth Station Inaugurated  
     (Paris AFP, 24 Jun 85) ..... 80

MADAGASCAR

Briefs  
     TASS, ANTA Cooperation 81

MOZAMBIQUE

Briefs  
     Pact With IPS 82

NIGERIA

Briefs  
     Army School Head on Communications 83  
     Government To Change TV Authority 83

SOUTH AFRICA

Viewers Fund Ciskei Television Station  
     (Graham Fysh; Port Elizabeth EVENING POST, 5 Jun 85) ..... 84

Briefs  
     SABC Head Discusses Educational Television 85  
     TV3 Transmitter Starts Operation 85

ZAIRE

Romania Offers Assistance in Telecommunications  
     (Kinshasa AZP, 1 Jul 85) ..... 86

USSR

Ideological Subversion Via Space  
     (Moscow SELSKAYA ZHIZN, 26 Jun 85) ..... 87

WEST EUROPE

EUROPEAN AFFAIRS

Telecommunications R&D Program 'Race' in Definition Phase (D. Levy; Paris ELECTRONIQUE ACTUALITES, 12 Apr 85) .....	89
Agreement Signed on Use of European 'Olympus' Satellite (Paris AFP SCIENCES, 30 May 85) .....	92
Seven Firms in Joint Second-Generation 'Eutelsat' Proposal (Paris AFP SCIENCES, 6 Jun 85) .....	94
Briefs	
European Public-Switching Research	95

BELGIUM

Six Firms Vie for Huge Telephone Contract (Zurich NEUE ZUERCHER ZEITUNG, 19 Jun 85) .....	96
--	----

DENMARK

Opposition to Hybrid Network Makes Realization Uncertain (Knud Lindholm Lau; Copenhagen BERLINGSKE TIDENDE, 31 May 85)	99
Agency To Inaugurate Electronic Mail Network This Year (Sv. Aa. Jensen; Copenhagen BERLINGSKE TIDENDE, 30 May 85)	101

FEDERAL REPUBLIC OF GERMANY

Cabinet Earmarks DM939 Million for Data Systems (Hamburg ARD Television Network, 25 Jun 85) .....	103
FRG Research Network 'DFN' Promotes Data Exchange (G. H. Altenmueller; Duesseldorf VDI NACHRICHTEN, 15 Mar 85)	104
DBP Designs ISDN System According to CCITT Standards (Peter Kahl; Heidelberg NACHRICHTEN ELEKTRONIK & TELEMATIC, Jan 85) .....	106

FINLAND

Satellite To Bring Programs From Other Nordics' Television (Helsinki HELSINGIN SANOMAT, 12 Jun 85) .....	111
Decision on Nordics' Tele-X Network Awaits Fall Election Results (Editorial; Helsinki HELSINGIN SANOMAT, 16 Jun 85) .....	112
Briefs	
Tele-X Advancement	113

FRANCE

Decrease in Orders at Alcatel-Thomson Space (H. Pradenc; Paris ELECTRONIQUE ACTUALITES, 12 Apr 85) ...	114
PTT Invests FF 2 to 3 Million in Telematics, Software (Paris ELECTRONIQUE ACTUALITES, 5 Apr 85) .....	117
Equipment at Mulhouse Earth Station for Telecom 1 (Paris REVUE FRANCAISE DES TELECOMMUNICATIONS, Feb 85) ...	119
CIT-Alcatel Enters U.S. Long-Distance Market (D. Levy; Paris ELECTRONIQUE ACTUALITES, 29 Mar 85) .....	122
Briefs 'Spot' Successors by 1990	124

ICELAND

Freedom of Air Will Bring Ratings War (Einar Sigurdsson; Reykjavik NEWS FROM ICELAND, Jul 85) ..	125
Private Broadcasting To Begin Next Year (Reykjavik NEWS FROM ICELAND, Jul 85) .....	127

SWEDEN

Swedish-EEC Joint Research Agreement Reached (Bjorn Anders Olson; Stockholm DAGENS NYHETER, 12 Jun 85).	128
--	-----

AUSTRALIA

REPORTAGE ON PROGRESS IN NATIONAL SATELLITE DEVELOPMENT

Controversy Continues Over Structure

Sydney THE AUSTRALIAN in English 20 May 85 p 12

[Article by Helen Meredith]

[Text]

"THE development of a national satellite system is a catalyst for change that will create a revolution in Australia's communication system," general manager and chief executive of Aussat Pty Ltd, Mr Graham Gosewinckel, said in Sydney last week.

"It is a challenge to the norm, to what has been for the past 100 years or more the accepted way in which we provide communications services, and as with anything that threatens change or established practice, it was bound from the start to be controversial."

Mr Gosewinckel was delivering the Noel Griffiths lecture to the Public Relations Institute of Australia.

He said controversy had raged ever since 1977 when the task force set up by the Federal Government recommended that a national satellite system be established.

The controversy was not only in terms of what the

system should be capable of doing, but whether in fact there should even be a system at all.

From the time Aussat Pty Ltd was formed in late 1981 the debate had covered such matters as how the company should be owned, if it should be publicly owned or partly privately owned, or should be part of Telecom, a new statutory corporation or a separate government body.

Mr Gosewinckel said the decision to create Aussat had been, in terms of ownership and structure, unusual in Australian commercial and government organisations.

It was not a statutory corporation. It had been established under a memorandum and articles of association which required it to conduct its business in a non-discriminatory way, to set fair and equitable charges and to return a dividend to its shareholders.

"For all intents and purposes Aussat conducts its business as a normal commercial tax-paying enterprise," Mr Gose-

winckel said.

Even the manner in which the satellite project was funded was unusual, he said.

Equity capital — taxpayers' investment — stood at a maximum of \$100 million, while the remaining funds for the project were provided through commercially negotiated banking loans totalling more than \$350 million.

It was not until April last year that it was decided Aussat would remain essentially a government-owned organisation, with the Federal Government holding 75 per cent and Telecom the remaining 25 per cent.

Despite the controversial nature of the structuring of the Aussat organisation, it was the use of the satellites for communication purposes that would continue to be the subject of intense debate, Mr Gosewinckel said.

"Naturally in a project of this magnitude there are the sceptics and knockers."

"But the sceptics and knockers will be proven wrong," Mr Gosewinckel predicted.

## Contract Combines Resources

Sydney THE AUSTRALIAN in English 20 May 85 p 12

[Article by Helen Meredith]

[Text]

THE signing of a space contract between Telecom and Aussat heralded a new era for commercial and domestic users of communications services, the Minister for Communications, Mr Duffy, said.

Mr Duffy said Telecom was Aussat's first customer and the agreement represented a significant and historic milestone in the development of Australia's telecommunications system.

The combined resources of the two national carriers would be applied to developing communications in Australia.

The contract, signed in Melbourne, enables Telecom to lease transponder capacity on the Aussat satellite system to

provide telecommunications services across the nation.

The first two satellites are to be launched in the second half of this year.

The use of Aussat's satellite technology and new forms of terrestrial services, such as digital radio concentrator systems being installed in remote areas by Telecom, would greatly enhance and strengthen the existing telecommunications infrastructure, Mr Duffy said.

By using the satellite, Telecom will be able to extend business services through its Iterra program to very remote parts of Australia.

"The complementary nature of the space and terrestrial

technologies would ensure the most efficient use of Telecom's network.

"It would also lead to the development of new services in highly important areas, such as distance education, and the provision of health care for people disadvantaged through living a long way from cities and towns."

Mr Duffy said high-risk ventures, such as mining and exploration, would be carried out in a more cost-effective way through vastly improved data transfer and telephonic communications and better television and radio reception for people working in remote areas.

## Military Use Considered

Sydney THE AUSTRALIAN in English 20 May 85 p 12

[Article by Ross Peake]

[Text]

THE Department of Defence is examining the possibility of incorporating a national satellite communications component in the overall defence strategic communications system.

The Minister for Defence, Mr Beazley, said recently that the proposed system, if approved, would use Australia's Aussat satellite system.

The plans call for earth stations to be established at major defence bases and transportable earth stations to be used by forces deployed in Australia.

Mr Beazley said an invitation to register interest to supply the earth stations had been released around the world.

Subject to further government consideration, tenders

would be invited later this year.

Mr Beazley said Australian participation was expected to exceed 40 per cent of the cost.

## Remote

"The proposed satellite communications system will complement the existing land-based system and would provide a greater degree of security, wider coverage, and greater flexibility and survivability," he said.

"The development of this system would allow the Defence Force to operate more effectively in the remoter areas of Australia where land-based communications systems are not well developed and radio is not always reliable."

TV Network Negotiations Continue

Sydney THE AUSTRALIAN in English 25-26 May 85 p 3

[Article by Errol Simper]

[Text]

REPRESENTATIVES of the three commercial television networks were still negotiating with Aussat late last night over whether they would lease transponders on Australia's planned domestic satellite system.

The networks have been unwilling to commit themselves to hiring satellite space since the Federal Minister for Communications, Mr Duffy, indicated that they would not be encouraged to beam their signals direct to remote and regional areas.

Instead, four zonal remote area television licensees are to be set up - likely to be consortiums of existing regional television operators - which, the networks say, would severely

curtail the use to which they could put the satellite.

However, in a statement on Thursday Mr Duffy went some way toward meeting the networks' requirements by saying that the Government hoped regional television operators would be providing three commercial services within three years and by not later than 1990.

This would provide a bigger market for programs and national advertising, which the metropolitan networks could service.

Mr Duffy's suggestion that regional stations speed up the introduction of three commercial channels was described by the Australian Telecommunications Employees Association

last night as "ill-considered" and a blueprint for national networking.

The chief executive of Aussat Pty Ltd, Mr Graham Gosewinckel, said Aussat had had to impose some kind of deadline because it needed to know whether or not the networks intended to take up the transponders.

The 30-watt transponders would cost each of the networks - Ten, Seven and Nine - \$3.36 million a year. The second satellite, which the commercial stations would use, is expected to be launched in October. The first satellite, likely to be used largely by the ABC, is expected to be launched in August.

Loans for Satellites Signed

Melbourne Overseas Service in English 0830 GMT 24 Jun 85

[Text]

The management of Australia's proposed national satellite system -- Aussat -- has signed an agreement to borrow almost \$400 million to finance the system. Aussat's general manager, Mr Graham Gosewinckel, said the funds would be used to buy and launch three satellites and to establish major city earth stations. Mr Gosewinckel said the funds which would also cover insurance costs had been raised entirely within the Australian banking community. Aussat's first satellite is due to be launched from Cape Canaveral in the United States in 2 months.

CSO: 5500/4342

CAMBODIA

BRIEFS

PRK MEDIA DELEGATION IN MOSCOW--The PRK radio and television delegation, which is visiting Moscow at the invitation of the Soviet radio and television commission, is continuing its activities here. The delegation is led by Comrade Kim Yin, member of the KPRP Central Committee and director general of the PRK radio and television. During its stay, the Cambodian colleagues will be introduced to the structure and principle of the Soviet radio and television. Today, the Cambodian delegation was received by Comrade Sergey Lapin, chairman of the State Committee for Television and Radio of the Soviet Union. In a cordial and friendly atmosphere, the two sides held talks on various issues aimed at further expanding cooperation between the organizations of the two countries. [Text] [Moscow in Cambodian to Cambodia 1330 GMT 26 Jun 85]

CSO: 4212/89

1 August 1985

HONG KONG

## PREPARATORY COMMITTEE TO FORM MEDIA COUNCIL SET UP

Hong Kong SOUTH CHINA MORNING POST in English 10 Jun 85 p 2

[Text]

AFTER years of discussion, the media in Hongkong has finally moved to set up a body to control abuses and to maintain the standard of ethics in the media fields.

A preparatory committee was established during a meeting on May 28, which was followed by a press release, put out by the Government Information Service which called on the public to give its views on the formation of a Media Council.

The press release said that a preparatory committee had been formed, but it failed to identify the people involved, except for those holding the offices of chairman, vice-chairman and honorary secretary.

It said judge, Mr Justice Simon Li, "had been invited to become chairman by the members" — without qualifying who the members were, while Mr Justice Kutlu Faud and Mr Archie Zimmern, QC, were elected vice-chairmen, and Mrs Doreen Dutton became the honorary secretary.

Besides the four people who were named, however, *The Standard* has learned the names of 12 other people who attended the first meeting of the preparatory com-

mittee. They are all top executives in local media and prominent professionals.

The list of those attending the first meeting showed that they came from a variety of backgrounds.

There were media men from television and radio, and the printed media; of the English and the Chinese press; from the employers organisations and from employees industrial unions. A Legislative Councillor and judges and lawyers were also present.

The membership of the new council appears to cover the entire political spectrum with some members pro-Beijing, others pro-Taipei, and others preferring the British line.

The names of the 16 members who attended the first Media Council meeting are:—

- Mr Justice Simon Li, Justice of Appeal, a public figure of independent and impartial image who was appointed by the British government to the team monitoring the work of the Assessment Office last year;

- Mr Justice Kutlu Faud, Justice of Appeal;

- Mrs Selina Chow, Legislative Councillor, who has keen interest in mass media and mass entertainment;

- Mr Archie Zimmern, QC;

- Mr David Robinson, solicitor;

- Mr Leslie Sung, solicitor;

- Mr Stuart Wilkinson, the Director of Broadcasting in charge of Radio Television Hongkong, and an appointed member of the Broadcasting Review Board.

- Mr Peter Pun, assistant general manager of Commercial Radio;

- Mr Robert Chan, general manager of the Television Broadcasting Limited;

- Mr Raymond Wong, news controller of the TVB;

- Mr Deacon Chiu, chairman of the Asia Television;

- Mr Robin Hutcheon, former editor-in-chief of the *South China Morning Post* and chairman of the Newspaper Society. Mr Hutcheon has been actively promoting the setting up of a Media Council.

- Mrs Doreen Dutton, Mr Hutcheon's secretary in SCMP;

- Dr Margaret Ng, executive editor of *Ming Pao Daily News*;

- Mr Cliff Bale, chairman of the Hongkong Journalists Association and a reporter at RTHK;

- Mr Chuck Stolbach, from the Hongkong Publishers Society.

Many of the people invited to the first meeting of

the Media Council were unable to attend.

Miss Sally Aw, the chairman of the Sing Tao Newspapers, Mr Li Xia-wen, the chief editor of *Ta Kung Pao*, and Mr Brian Tisdall, the newly elected president of the Law Society, were among the absentees.

There appears to be some confusion among the members of the council about whether they are representing themselves or organisations. Certainly here is a number of possible council members who, by their profession, are entitled to sit on the council and are not represented. In the main these are members of the Chinese press.

Most of the Chinese-language newspapers claim they had no knowledge of the meeting beforehand, according to an editorial in the *Hongkong Financial Daily* (May 31).

One member has already said that the council would simply become "the game for the big boys" unless the membership is enlarged.

However, a survey conducted earlier by the Newspaper Society which has not yet been released, showed that news organisations are reluctant to comment on the formation of a media council.

CSO: 5550/0113

1 August 1985

HONG KONG

## POWERS BILL SAID TO ENDANGER FLOW OF INFORMATION

Hong Kong SOUTH CHINA MORNING POST in English 12 Jun 85 p 18

[Article by Agnes Chen]

[Text]

The Legislative Council (Powers and Privileges) Bill, if introduced, could be abused by a future government, the Asian Editor of Fortune Magazine, Mr Louis Kraar, warned yesterday.

He also emphasised the risk of Hongkong becoming a backwater without a free flow of information instead of a global financial centre.

And he said it was up to Hongkong to decide what to do.

Mr Kraar said it was quite clear the Bill, if introduced, could have a serious effect on local press freedom — if not in the hands of the present administration, then in the hands of some future government beyond 1997.

He said he found it rather odd that the British Government, which worked so hard to negotiate a joint declaration to preserve the basic freedoms of Hongkong, would now voluntarily compromise some of those freedoms.

"If Hongkong is to remain essentially as it is now for 50 years beyond 1997, why change it now?" he asked.

Mr Kraar, who was speaking to reporters after addressing a Rotary Club of Hongkong lunch meeting, said anything that prevented journal-

ists from serving the public was alarming.

For example, if a legislative body was to meet secretly to conduct business that might affect public interests, journalists learning about it had a duty to report it, he said.

Mr Kraar expressed fear that Hongkong could radically change from a global financial centre to a backwater if there was no free flow of information.

Financial centres, he said, depended on money flow which in turn depended on information.

Mr Kraar said if investors could not get their hands on information freely to base their decisions, they would go somewhere else with freedom of information.

On the warning by the former Chief Secretary, Sir Philip Haddon-Cave, to local journalists that there was a limit to criticism the Government could take during a delicate transition period, Mr Kraar said: "I think it is important the media show responsibility and be aware of the sensitive period, but I think the present Government can stand up to a lot of criticism."

CSO: 5550/0112

HONG KONG

## NEWSMAN CALLS FOR FREEDOM OF PRESS IN BASIC LAW

Hong Kong SOUTH CHINA MORNING POST in English 17 Jun 85 p 9

[Article by Patricia Tse]

[Text]

If freedom of the press dies in Hongkong, it would affect Hongkong's stability and prosperity, the chairman of the Journalists' Association, Mr Cliff Bale, said yesterday.

And the best way to protect freedom of the press after 1997 and in the transition period is through the Basic Law, he said.

Although the joint declaration had promised press freedom, the Basic Law should go a step further in stipulating exactly what kind of press freedom the people should have in Hongkong.

Mr Bale told a City Hall forum yesterday of suspicions among journalists, sparked off by several incidents in the past year, that Hongkong was headed towards a more authoritarian system.

The forum called "Freedom of speech and the endangered species" was attended by about 100 members of the public and the press.

The incidents Mr Bale referred to included:

- The Legislative Council (Powers and Privileges) Bill, in its maiden form.

- The call by the Attorney-General recently for the establishment of an objectionable publications tribunal.

- The call made by Sir Philip Haddon-Cave for the press to regulate itself as too much criticism in the sensitive transitional period was bad for Hongkong.

- A similar call by a former editor of a Chinese newspaper.

- The banning of the press from the Carrion committal.

- Behind-the-scenes Government support for a media or press council.

Mr Bale said the Powers and Privileges Bill caused deep concern in his association as the original provisions did not give any right to the public or the press to enter the Legislative Council chamber to listen to certain meetings.

A strange concept called "intentional disrespect" was introduced which would have made any sort of critical commentary potentially liable to criminal prosecution.

The proposed tribunal for objectionable publications had also raised concern that it could be misused as a censorship tool instead of weapon against pornography.

Mr Bale, turning to a speech Sir Philip Haddon-

Cave had made recently at the Foreign Correspondents' Club, said Sir Philip described Hongkong as being in a sensitive transitional period when it might not be able to take too much adverse criticism.

A former newspaper editor, Mr Sze Chusian, vice chairman of the Hongkong Belongers, had also written an article recently on similar lines, saying that Hongkong's main objective is prosperity and stability and this outweighs the importance of freedom of the press and other freedoms.

All these incidents made journalists wonder whether Hongkong is stepping backwards in order, perhaps, to be more in line with China — since Hongkong is more open and advanced in allowing freedom of speech and of the press.

People in business depend on the free flow of information to make the best decisions, and this free flow is even more important as Hongkong is an international business centre, he said.

"If this is curbed, international companies would limit their activities here or even move elsewhere," Mr Bale said.

Freedom of the press is not only extremely important in this respect, but is also the first thing to go when a Government plans to curb other freedoms, he said.

Mr Bale said he believed Hongkong people can preserve the freedom promised in the joint declaration if they would only fight for it.

He cited two examples of recent victories for the press.

Last October, during the Carrion committal proceedings, when the media was excluded from attending even though the public was allowed.

This decision was reversed but it would not have been so if the media did not fight it in court, he said.

The Legislative Council (Powers and Privileges) Bill was also amended, with the most contentious clause 20, which was a direct attack on press freedom, being deleted, clause 8 reworded in a much more acceptable form and clause 17(d) also deleted.

The association is concerned, however, over alternative legislation promised by Miss Maria Tam and Mrs Selina Chow on the prohibition of coverage of closed meetings.

1 August 1985

HONG KONG

## 'BREAKTHROUGH' MODEM RELEASED

Hong Kong HONGKONG STANDARD in English 13 Jun 85 Supplement p 1

[Text]

DATA-CRAFT Hongkong, the leading data-communications specialist, has introduced a new modem, manufactured in the company's Australian factory which has been described as a breakthrough product in specifications and price.

The Datacraft 5096 is a Universal Data Modem supporting communications at 9600, 4800 or 2400 bits per second but is priced lower than the current generation of low-priced 4800 bps-only modems.

The new Universal Data Modem, which was developed solely by Datacraft's own engineers, is the only high speed data modem supplied by the Australian Telecommunication Authority. The product has now gained type-approval from Hongkong Telephone Company.

Datacraft's Melbourne factory is currently producing the 5096 UDM at a rate of 1200 units per month, most of which are going to Australian Telecoms. However plans are ready for increasing the rate of production to meet the expected demand from the SE Asian region.

The Datacraft 5096 can operate in point-to-point or multipoint fast-

poll modes using the standard CCITT protocols for the corresponding communications rates:  
9600bps — CCITT V.29;  
4800bps — CCITT V.27;  
2400bps — CCITT V.26.

"We call this a breakthrough product because no one before has been able to offer the kind of performance given by this modem at such a low price," explained Mr Kevin Slattery, Managing Director, Datacraft Hongkong.

Mr Slattery added that the 5096 UDM has already generated considerable interest among those datacoms users who were shown it in pre-release form, but that serious marketing of the new product has been awaiting Hongkong Telephone approval, which was just recently granted.

"Because of the interest in this product already shown in the marketplace, we are considering appointing OEM's to help market the new product," said Mr Slattery.

Datacraft Hongkong is a leading supplier of data-communications equipment and also offers a design and consultancy service for the installation and maintenance of more complex datacom networks.

CSO: 5550/0116

1 August 1985

HONG KONG

## BRIEFS

MINICOMPUTER CONNECTION APPROVED--Hongkong Telephone Co Ltd has given approval for the connection of the ICL System 25 mini-computer to their X25 based Datapak service which provides economical and reliable packet switch connection throughout the world. Although System 25 is better known in Hongkong as a small business computer, it is also known worldwide as an excellent networking mini-computer. As part of the ICL Networked Product Line, the System 25 takes full advantage of Telco packet switching to provide remote access, distributed transaction processing, and file transfer to other ICL systems or to other manufacturers equipment throughout the world. The X25 facility is implemented on the System 25 as firmware in the standard communications coupler; no hardware or programme changes are therefore required to take advantage of the feature. System 25 is used in a varied assortment of business; users include large multiple retailers, multinational manufacturing firms and international distributor of products. British Telecom uses the System 25 for their motor transport division. [Excerpt] [Hong Kong HONGKONG STANDARD in English 6 Jun 85 Supplement p 3]

DATA-CRAFT'S NETWORK PROCESSOR--A new intelligent X.25 network processor that can accommodate up to 1000 separate channels has been introduced by Datacraft Hongkong, the leading supplier of datacommunications equipment in the territory. The new IXP 660 Processor is manufactured by the US-based company Motorola Information Systems. Designed to increase the flexibility and cost effectiveness of X.25 networking, the IXP 660 integrates fully with the fast growing range of X.25 products now appearing on the market. "Host computers and X.25 terminals can be connected directly to the IXP 660 via anyone of 28 synchronous interfaces, each operating at link speeds of 72KBPS EDCN, can carry up to 255 separate data channels, depending on the application. The new device is also compatible with the IXP 650 and the complete Codex 6000 series processors," explained Mr Richard Duval, Marketing Manager of Datacraft. "A maximum of 1000 channels can be supported by the new processor, depending on the application involved. When a user defined routing is used, the IXP 660 is unable to establish connection to a particular destination port, it will automatically 'hunt' for the next free port of the same resource class. This means that a far more efficient network system is achieved," Mr Duval explained. [Excerpt] [Hong Kong HONGKONG STANDARD in English 6 Jun 85 Supplement p 3]

CSO: 5550/0114

INDONESIA

MINISTER ON LAUNCHING OF PALAPA B-3 SATELLITE

BK131234 Jakarta Domestic Service in Indonesia 0600 GMT 13 Jul 85

[Text] The Palapa B-3 satellite is scheduled to be launched in July 1986 with an Indonesian loading expert aboard. The tourism, postal, and telecommunications minister, Akhmad Tahir, disclosed this after calling on President Suharto at Cendana Mansion this morning. Minister Tahir reported to President Suharto on the termination of functioning by the Palapa A satellites. The Palapa A-1 satellite finished its work last May after functioning for 7 years. The Palapa A-2, which is being rented by a neighboring country, will be out of its orbit in November at the latest.

Minister Akhmad Tahir explained that the functions of the Palapa A-1 satellite have been taken over by the Palapa B-1 satellite. The government is making preparations for the launching of the Palapa B-3 satellite in July next year following the failure of the launching of the Palapa B-2 satellite.

The tourism, postal, and telecommunications minister also reported on the planned arrival of a National Aeronautics and Space Administration [NASA] expert, Dr Robert (Sprichter), in connection with the selection of an Indonesian astronaut and on the planned departure of a student, Bambang Trionon, for the United States to attend a summer program at NASA.

CSO: 5500/4343

INDONESIA

BRIEFS

PALAPA A-1 SENT INTO DISTANT ORBIT--Jakarta, 14 Jul (AFP)--Indonesia's Palapa A-1 telecommunications satellite, which sopped functioning in 1983, has now been sent into distant orbit, it was announced here. Ahmad Tahir, minister of tourism, posts and telecommunications said yesterday that the satellite was sent into orbit May 6. Launched in 1976, the Palapa A-1 was built to operate for 7 years, but it was sent into an orbit situated 58,000 kilometers (36,000 miles) instead of 36,000 kilometers (22,000 miles) above the earth. The satellite was replaced in 1983 by the Palapa B-1. The minister said that the U.S. space shuttle with an Indonesian astronaut on board is to launch Indonesia's New Palapa B-2 satellite in 1986. The first Palapa B-2 was sent into an incorrect orbit by the shuttle in February 1984 and was later retrieved by the shuttle discovery in November last year.  
[Text] [Hong Kong AFP in English 0705 GMT 14 Jul 85 HK]

CSO: 5500/4343

JAPAN

NO PROGRESS IN TELECOMMUNICATIONS TALKS WITH U.S.

OW071421 Tokyo KYODO in English 1235 GMT 7 Jun 85

[Text] Tokyo, June 7 KYODO -- Japanese and U.S. experts on wireless telecommunication equipment Friday ended four days of talks here on the opening of the Japanese market to U.S. products without reaching a conclusion, conference sources said.

The sources said the experts discussed U.S. requests on the entry into Japan of automobile phones based on the U.S. system, simplification of licensing and approval procedures for wireless equipment and type-certification on the basis of foreign makers' data.

The Japanese side avoided a clear-cut reply to the automobile phone question, saying simply that the matter is being discussed at the current session of the telecommunication technology council. They also put off replies on the two other questions for a future meeting, the timetable for which was left undecided.

CSO: 5560/14

JAPAN

REPORT FAVORS ASIAN SATELLITE TELECOMMUNICATIONS NETWORK

OW111309 Tokyo KYODO in English 1204 GMT 11 Jun 85

[Text] Tokyo, June 11 KYODO -- The Economic Planning Agency Tuesday released a report advocating formation of an international telecommunications network covering the east Asian area in cooperation with South Korea and China.

The report, titled "Impact on Japan's Information Industry of the U.S. Communications Satellite and Information Industry," was prepared by Nippon Research Institute under assignment by the agency. The U.S. Administration has approved projects by U.S. firms, non-members of the International Telecommunications Satellite Consortium (Intelsat), to launch commercial communications satellites above the Pacific Ocean, the report said.

In Japan, three Japan-U.S. ventures -- Uchu Tsushing set up by Ford Aerospace Satellite and Mitsubishi group, Japan Communications Satellite Co. formed by Hughes Communications Inc., Itoh and Co. and Mitsui and Co., and Satellite Japan led by Sony Corp., Marubeni Corp. and Nissho Iwai Corp. -- have made public their plans to provide commercial services three years from now, according to the report.

Referring to these moves in Japan and the U.S., the report stressed the necessity of establishing a business data exchange network via communications satellites in eastern Asia by an organization involving Japan, China and South Korea.

The report also recommended promotion of foreign entry into the Japanese telecom market and legal preparations for protection of data and privacy to cope with internationalized and liberalized information systems.

CSO: 5560/12

MALAYSIA

## FUJITSU WINS TELECOMMUNICATIONS CONTRACT

Kuala Lumpur BUSINESS TIMES in English 3 Jun 85 p 1

[Article by Vong Nyam Ming]

[Text]

FUJITSU has been nominated by Telecoms to install the nation-wide fibre optic network which attracted eight international bids ranging from \$45 million to \$85 million.

The recommendation report was submitted to the Treasury and Finance Minister Daim Zainuddin for approval last week following a final tender board meeting on the bids on May 10.

The price difference between Fujitsu's and GEC Marconi's offer is about eight per cent. Fujitsu submitted its tender in partnership with Sapura Holdings and GEC Marconi with GEC Malaysia Sdn Bhd.

NEC, one of the early favourites to get the job because of its appointment to the pilot fibre optic project, was placed third in the Telecoms evaluation of the total package.

Total package evaluation took into consideration three elements — technical specifications,

financing, and price.

Phillips bid through two companies, but were placed fourth and fifth consecutively.

Phillips-Binafon-NKF was ranked fourth despite earlier predictions that the success of the NKF-Phillips partnership in the giant Saudi Arabia project would be repeated in Malaysia with the help of Binafon, one of the top two local cable laying companies.

When the tenders were opened, the Phillips-Binafon-NKF quote was found to be half as much again as Fujitsu's offer.

The Talasco-Fujikura-Phillips combination was placed fifth, LM Ericsson sixth and STC seventh. STC, a major UK telecommunications company, quoted through International Aeradio Sdn Bhd.

Telettra-Siecor, quoting through MOIC, put in the highest bid at \$81 million. Siecor is a joint venture between Siemens and the

US company, Corning Glass. MOIC quoted in four currencies to give more flexibility in hedging options.

GEC-Marconi's offer includes a \$11 million grant from the British government but after discounting, GEC-Marconi's offer is said to be still substantially above Fujitsu's.

The contract calls for the installation of about 200 routes connecting exchanges within a town while a few will be trunk routes between towns. Cable ducts themselves are expected to cost about \$10 million.

For Fujitsu, the contract will be its flagship in Malaysia and will help re-establish its foothold in the market — a footing which it lost when it was beaten to the backbone transmission system by Standard Elektrik Lorenz, the largest of ITT's telecommunications subsidiaries.

Telecoms should be signing its letter of intent

by June 12 — the tender validity deadline — but some sources say that there can be an extension of the tender validity period if last minute lobbying finds a sympathetic ear.

The chances of this happening can't be ruled out but other sources feel that Telecoms can ill-afford another hitch to the national telecommunications development plan which has as its first target 1.6 million working phone lines by the end of the year.

The technical recommendation will be a bitter blow to GEC Marconi — widely reckoned to be the most persistent bidder — which has been in a neck-to-neck race with Fujitsu. The bidding was so keen that Telecoms had to call the nine shortlisted bidders to re-submit prices by Apr. 19. The two-week deadline was at least one reason why Standard Elektrik Lorenz (SEL) pulled out from the second round bidding.

CSO: 5500/4341

1 August 1985

PEOPLE'S REPUBLIC OF CHINA

HAINAN IMPORTS ITALIAN MICROWAVE EQUIPMENT FOR RADIO-TV USE

HK310215 Haikou Hainan Island Service in Mandarin 0400 GMT 30 May 85

[Text] Haikou City yesterday held an agreement-signing ceremony for importing a full set of microwave circuit equipment from Italy for the district's radio and television broadcasting.

Representatives of the (Telai Tele) Company from Italy, the (Eda) Electronics Engineering Company from Hong Kong, the Hainan Joint Trading Company and Hainan Radio and Television Bureau signed the agreement.

The ceremony was attended by Lei Yu, principal responsible person of the Hainan District People's Government, (Zhang Jingtao), Standing Committee member of the District CPC Committee and director of the Propaganda Department; and others.

With the approval of the Hainan Administrative District's People's Government and Guangdong Province's Radio and Television Department, the district has agreed to import a full set of advanced microwave circuit equipment from the (Telai Tele) Company of Italy worth more than \$1.6 million. The equipment is able to simultaneously transmit three color television programs as well as to receive eight broadcast channels. Its standards are advanced ones of the 1980s.

After the agreement was signed, the equipment will be sent to the district in parts. It is expected that the equipment will be installed and tested during the first half of next year.

This microwave circuit is part of the microwave circuit of Western Guangdong, which links up with the district's 11 counties, cities and towns. The total length will be 509.6 kilometers. This circuit consists of 14 microwave relay stations. After being put into operation, the district's people of various nationalities will be able to watch the Central Television Station and Guangdong Television Station's three color television programs that very day, which will be transmitted from Guangzhou. The people will also be able to receive Guangzhou's multichannel broadcast programs. Therefore, the district's radio and television undertaking will enter a new stage.

Also present at the signing ceremony were representatives of Guangdong Province's Radio and Television Department and the No 2 Engineering Company of the Posts and Telecommunications Ministry.

PEOPLE'S REPUBLIC OF CHINA

## MERITS OF FIBER-OPTIC COMMUNICATIONS DISCUSSED

Shanghai XIANDAI TONGXIN [COMMUNICATIONS TODAY] in Chinese No 1, 8 Jan 85  
pp 1-2

[Article by Xiao Xizhang [5135 6932 4545]: "A Public Fiber-optic Communications Network"]

[Text] The development of fiber-optic communications systems in the public communications network may be summed up under four conditions: the first is high-capacity long-distance toll trunk circuits with service distances generally from 100 to several thousand kilometers. The second is toll legs or trunk circuits between major cities and their suburbs, with service distances commonly from over 10 to approximately 100 kilometers. The third type of condition is the use for trunk circuits between various branch exchanges and subexchanges within a local telephone network, with actual distances from 1 or 2 kilometers to more than 10 kilometers. The fourth condition is the application of fiberoptics to primary subscriber cables or direct lines in local telephone [networks]. This article will discuss the application and technical economics characteristics of fiber optic communications systems on the basis of these four types of conditions.

### I. Toll Trunk Lines

The more common long-distance telecommunications transmission facilities in use in China currently are, principally, 1800-channel medium coaxial cable carrier, 300-channel small coaxial cable carrier, 960-channel microwave and a large number of open-wire carrier circuits. Inasmuch as fiber-optic communications have a high traffic capacity, long relay hops, abundant sources of material, economize on nonferrous metals, are resistant to magnetic interference, are resistant to radiation, are corrosion-resistant, have strong security characteristics, and other advantages, in communication network development now and henceforth, they have a great competitive advantage. Not only will fiber-optic communications progressively replace traditional long-distance transmission measures, but they will also go hand in hand with communication satellites not under construction to become the two pillars in the development of our domestic long-distance communications network. The cost of satellite communication long-distance transmission circuits is low, but they will not be able to compare with fiber-optic communications from the aspect of security and communication reliability.

Multifrequency mutually controlled signals are used for register signaling in our country's current toll telephone exchanges. Should an exchange of communications pass over a single satellite circuit, the transmission time for each position of a mutual-control type signal would increase about 1.2 seconds. This would cause overall connection time to increase by an average of over 10 seconds. Such delays obviously lower the quality of communication service and at the same time are an uneconomical element which cannot be overlooked with respect to the providing of switching and transmission equipment. These problems are difficulties which cannot be overcome by communication satellites; however, when discussing fiberoptic communications, signal transmission delays need not even be considered. Therefore, the corresponding advantage of fiberoptic communications is most obvious.

In brief, in view of the above reasons combined with the developmental situation of fiberoptic communications abroad, henceforth the emphasis in the development of fiberoptic communications will shift from local telephone to long-distance communication. It is true that many inherent advantages are present in fiberoptic communication, but to realize the advantages in actual engineering practice, we must still organize scientific research, production, communication construction, communication maintenance and other strengths into a coordinated whole, solidly performing detailed work before results can be achieved. Discussing long-distance communication, fiber optic communications should emphasize the development of long wavelengths and advance in the direction of single-mode fiber optics. The distance between microwave relay stations in general use is about 50 kilometers. For fiber optic communications regenerative repeater distances to reach this would be difficult in the near term. Not only does the short distance between stations bring on problems of construction difficulties and increased investment, but, more importantly, it creates difficulties in maintenance and management. Therefore, in the development of fiber optic communication in the long-distance communication field, the principal objectives are improving fiber optics and devices, and increasing distances between relay stations while at the same time researching in earnest the problem of unattended regenerative repeater stations. This topic affects two other aspects. The first is the problem of the reliability and stability of the optical regenerative repeaters themselves; the reliability index of optical regenerators must be specific and must also be more than one order of magnitude higher than the reliability index of the terminal equipment. The second aspect is that active research must be carried out regarding power transmission to unattended repeaters, their alarm equipment, remote control, telemetering, and other security and protection measures. These techniques are very important in engineering practice, and will also have the effect of ensuring the promotion and application of optical fiber communication.

Practically all transmission equipment in current use in long-distance communication networks is of the analog type. Fiber optic communication is generally suited to digital transmission, therefore in fiber optic communication the problems of analog-to-digital and digital-to-analog switching as well as signal and order switching must be solved. Analog-to-digital and digital-to-analog switching techniques on a single-voice-channel basis are already mature and are widely used. The advanced method, however, is to

switch with carrier groups or supergroups as the basis to realize FDM/TDM\* switching, this being a new technique of major significance in the application and development of fiber-optic communication and of great importance in the step-by-step digitizing of communication networks.

With our country's very long coastline and coastal islands scattered all along the shore, it is anticipated that henceforth as economic development of the ocean is promoted, the development of coastal communications will be accelerated, and microwave and undersea optical cable will have a high probability of becoming the principal transmission media for communications in seacoast areas. Therefore developmental research in undersea optical cable and undersea regenerative repeaters is undoubtedly very important and should receive sufficient emphasis.

## II. Suburban Trunk Circuits and Toll Legs

Currently in communication transmission between large cities, central cities and satellite cities and towns, and between suburban xian, primary reliance is placed upon carrier circuits on open wire or carrier circuits on balanced quad cable. Distances for such communication are roughly in the tens of kilometers. It is estimated that digital transmission equipment to be used henceforth in this field will be limited to the following types

1. PCM on balanced cable
2. Digital microwave
3. Fiber-optic cable

Similarly, an important premise in the application of fiber-optic communication between cities and xian is whether to use long wave-length multimode fiberoptics or to advance to the adoption of single-mode fiber-optics. Discussing the situation in the Municipality of Shanghai, the greater part of the distances between xian centers and satellite industrial cities and towns on one hand and the urban area are from 30 to 50 kilometers, with the greatest distance being as great as more than 80 kilometers. With such distances, regardless of whether long wave-length technology or short wave-length technology is adapted, the establishment of optical regenerative repeater stations cannot be avoided. Such regenerative repeater stations should be unattended if possible, otherwise it will be difficult to promote wide utilization.

The economic benefit of fiber-optic communication still depends upon the amount of service which can be foreseen practically on the same communication route. Speaking of the near term requirements of this city, the placing of a tertiary PCM group (480 voice circuits) between most suburban xian and the tandem office in the urban area is already sufficient. A minority of the area could need to activate a fourth order group or utilize multiple parallel tertiary group systems.

---

\*Frequency-division multiplex transmission/time-division multiplex transmission)

Currently, the telephone is the principal and only method of communication between municipalities and xian, with data and image communication traffic capacity being limited in the near term. Should the need arise, it may be met temporarily by means of leased dedicated lines. The development of data communications networks between municipalities and xian is generally somewhat slower than development within municipalities.

### III. Interoffice Trunk Circuits in Local Telephone Networks

Trunk distances between local telephone offices generally do not exceed 2-5 kilometers, with exceptionally long ones up to more than 10 kilometers. Most fiber-optic communication development abroad has started with local telephone office trunks, a possible reason being that the transmission characteristics of early production optical fibers and optical devices were deficient, so that they could only be used relatively easily to good effect in short-distance communication. Fiber-optic communication is a type of digital multiplexing system, and when replacing metallic pairs with such systems, terminal equipment, power sources, buildings and other factors must be increased at both ends. These buildings and terminal equipment bear no relation to communication distance, therefore economic rationality is not easily achieved by the application of fiber-optic communication to short-distance trunking. The transmission attenuation of multimode short-wavelength optical fibers has now fallen to 2-3 decibels per kilometer, and that of long-wavelength multimode optical fibers can be as low as 0.5 decibels. Therefore, high-quality fiber-optics systems with low transmission attenuation and a broad [frequency] band should achieve dominance in long-distance communication. They should be placed into logical use in local telephone trunking in accordance with the actual situation. For example, conditions for relatively wide application exist in local telephone networks for low-priced optical fibers with bandwidth from 200 megahertz to 400 megahertz and attenuation between 3 and 5 decibels.

Practically, the greatest advantages of using fiber-optic communication in local telephone networks lie in saving conduit ducts, reducing road surface excavation, and increasing the speed of construction. Local telephone offices in Shanghai have already adopted the internal conduit method, a construction technique in which a conduit duct is divided into sections to lay three optical cables. Optical cables generally consist of 12, 24 or even more conductors. Therefore it is temporarily not pressing to adopt fiber-optic communication systems with higher-order groups and higher code speeds for telephone networks within cities. Tertiary groups (480 voice channels) may be activated for interoffice trunks where distances are relatively short and traffic volume is very high, and secondary group systems (120 voice channels) may be activated for long interoffice distances to meet traffic growth requirements for a fairly long time. Further capacity expansion may be achieved by the method of increasing the number of systems activated. Of course whether this suggestion is reasonable will be determined by looking at the bandwidth-to-cost ratio of the fiber-optic system. Should there be a technological breakthrough making broadband systems both reliable and economical, we might utilize fourth order group systems (1920 voice channels) where necessary.

The characteristics of local telephone trunking are short distances, large numbers, complex signaling, and high tension in operations rooms. Henceforth, in the application of fiber-optic communication systems in local telephone networks, they should be used between digital exchanges wherever possible, because with the introduction of optical-fiber communication systems into digital exchanges, the installation of huge primary group terminals and signal interface equipment may be avoided, requiring only optical terminals and secondary or higher group multiplex terminals. Comparing digital offices with analog offices, the volume of fiber-optic terminal equipment may be reduced by three-quarters, with corresponding reduction in floor space occupied and investment required as well as greatly simplified maintenance. When a fiber-optic communication system is used as trunk transmission equipment between a digital exchange and an analog exchange, the installation of digital-to-analog conversion equipment cannot be avoided at the analog end, that is PCM primary groups and signal interface circuits. This makes the whole system complex but it is still somewhat more economical and rational in comparison with communication between analog exchanges. Therefore the use of fiber-optic communication systems or other digital transmission equipment within a completely analog local telephone network is not very economical.

#### IV. Local Telephone Subscriber Lines

Traditional intracity telephone subscriber cable distances are comparatively short, have relatively small diameter conductors, are generally well dispersed, and to adapt to the characteristic subscriber requirements for flexibility and change, subscriber lines generally are of two modes --spliced distribution and multiple distribution. Telephone subscribers in the Shanghai Municipality primarily use the multiple tapered distribution mode. Generally speaking, to supply a voice-frequency cable pair to a subscriber from a telephone branch exchange requires on the average a 400-to-500-yuan investment, including engineering expense. Currently it would be comparatively difficult to replace subscriber cable with optical fibers. First, looking at it from the economic view, to bring in a single-core fiber--optic cable from a subscriber 3 kilometers distant from the exchange would require an investment of 3000-4000 yuan for the fiber-optic cable alone, to which must be added the optical-electrical conversion equipment and digital-analog conversion equipment at both ends, which could make the total investment an order of magnitude greater than that of voice-frequency cable. Besides, for some time to come, wideband high-signaling-rate data communications will not become a broad requirement of a great number of subscribers, and can only be limited for use by certain specified subscribers. Therefore, it may be said that, unless our country's electronics industry can achieve a fundamental breakthrough, the probability is very low for the realization of fiber-optic communication for subscriber distribution. Of course it is quite reasonable to use fiber-optic communications between digital program-controlled exchanges and their remote subscriber modules. Although such employment of fiber-optic communications systems is identical to trunking between digital exchanges, from the viewpoint of effectiveness it may be counted as subscriber lines relying on fiber-optics for their extension. In brief, the higher the level of digitization in local telephone networks, the greater the capability of fiber-optics to bring their advantages into play.

Therefore, fiber-optic communication and network digitization are interdependent.

The development of integrated services digital networks (ISDN) is already in research programs of developed countries and testing is in progress in local networks. Some units in our country are also carrying on investigative research. The speed with which integrated service digital networks will be realized depends principally on the society's science and technology, the society's economy, and the level of development of the people's standard of living. From the view of the requirements of our country's general development objectives according to the four modernizations, that in the latter part of this century we will achieve the level of developed nations at the end of the seventies and the beginning of the eighties, we must definitely put our hands to proceeding with the pertinent research topics, and must also occupy the necessary positions in the state or municipal long-range science and technology development programs. There is no doubt whatsoever that fiber-optic communication will become an important mainstay of the development of the integrated services digital network.

8174

CSO: 5500/4138

PEOPLE'S REPUBLIC OF CHINA

METHOD OF MEASURING OMNIDIRECTIONAL SATELLITE ANTENNA TESTED

Beijing DIANZI KEXUE XUEKAN [JOURNAL OF ELECTRONICS] in Chinese Vol 6, No 6,  
Nov 84 pp 495-502

[Article by Zhang Jinbiao [1728 6855 2871], Wireless Department, Tianjin  
Institute of Technology: "Method of Measuring a Flight Vehicle-based  
Omnidirectional Antenna"]

[Text] I. Introduction

There are two difficulties in measuring omnidirectional antennas, especially ultrashort wave omnidirectional antennas, which are mounted on satellites and other flight vehicles.

1. Omnidirectional antennas on satellites have microwave wave sections and ultrashort wave sections. Because of the demands of the satellite shell and the transceiving distances, measuring the radiation characteristics of an omnidirectional antenna sometimes must be carried out in an external field. Because the wavelength of the ultrashort wave sections in particular is long, the transmitting antenna beam used to irradiate the diameter of the omnidirectional antenna being measured cannot be too narrow. Thus, when measuring the radiation characteristics of an omnidirectional antenna using the free space wave method, reflection and scattering produced by the earth's surface and other obstacles is unavoidable. This makes the wave motion of the inner field of the measured antenna's (i.e., the receiving antenna) diameter very large. And the antenna being measured is also an omnidirectional antenna thus waves from all directions can be received and even make the measurement error larger and even be distorted beyond recognition.

Documents [1] and [2] first presented the surface transmission field method which could resolve this problem. This method isn't a scheme to reduce surface reflection, but utilizes surface reflection to make the transmitting antenna's direct waves and the surface reflection waves coherent in the receiving antenna's diameter to create a narrow beam to irradiate the antenna being measured.

2. Because the beam of a satellite-mounted omnidirectional antenna is very wide, naturally an electric current is excited on the satellite's shell and thus the satellite-mounted omnidirectional antenna, especially the ultrashort wave omnidirectional antenna radiation field is the sum (i.e., iterative

addition) of the omnidirectional antenna and the satellite shell's radiation fields, therefore, the directional map, axial ratio of the polarization ellipse, and the polarized rotational direction of the satellite-mounted ultrashort wave omnidirectional antenna all change. Document [3] explains this problem from the theoretical standpoint.

These conditions create difficulties for measuring because these characteristics of the omnidirectional antenna must be known before the satellite is launched, otherwise before the satellite's attitude is stabilized, the telemetry data sent to the surface may not be received and signal interruption may be caused.

This paper presents a method for using the surface reflection field method to simultaneously measure the direction map, polarized axial ratio, and polarized rotational direction of a satellite-mounted ultrashort wave omnidirectional antenna. It analyses measurement error, especially when the transmitting antenna's axial ratio is not 1, and analyzes the gain of the measured antenna and the error created by the axial ratio. Use of this method for measurement of certain satellite ultrashort wave omnidirectional antennas has proven that it is feasible.

## II. Measurement Method

As described above, the measured antenna was used as a receiving antenna. The transmitting antenna first transmitted a left-hand circular polarized wave then transmitted a right-hand circular polarized wave, the signals of the left-hand and right-hand circular polarized waves received are added together to get the directional map of the measured antenna. Then this is compared with the standard gain antenna to get the gain of the measured antenna at this point. Then the results of two measurements are process to get the axial ratio of the measured antenna at that point. Through observation of which rotational direction received is stronger, the rotational direction of the measured antenna at that point can be determined.

1. Measurement of directional map and polarized rotational direction. As illustrated in Figure 1, the transmitting antenna's field is divided into components  $E_x$  and  $E_y$  and  $+z$  is taken as the propagation direction, thus we have

$$E = \alpha_x A_x(\theta, \varphi) e^{j(\omega t - \beta z)} + \alpha_y A_y(\theta, \varphi) e^{j(\omega t - \beta z + \theta)} = E_x \alpha_x + E_y \alpha_y \quad (1)$$

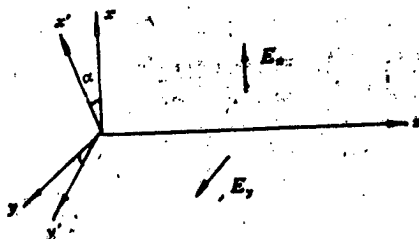

Fig. 1. Transmission field and coordinate system

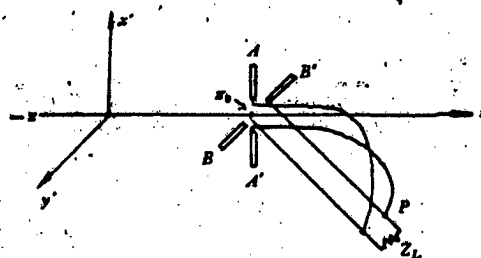

Fig. 2. Receiving antenna and its coordinate system

In the x-y plane, taking the x-axis counterclockwise direction angle of turn  $\alpha$ , we get:

$$\vec{E} = a_x E_x + a_y E_y, \quad (2)$$

in which

$$E_x = [A_x^2 \cos^2 \alpha + 2A_x A_y \cos \alpha \sin \alpha \cos \theta + A_y^2 \sin^2 \alpha]^{1/2} e^{i(\omega t - \beta z + \tau)} \frac{A_y \sin \alpha \sin \theta}{A_x \cos \alpha + A_y \sin \alpha \cos \theta},$$

$$E_y = [A_x^2 \sin^2 \alpha - 2A_x A_y \sin \alpha \cos \alpha \cos \theta + A_y^2 \cos^2 \alpha]^{1/2} e^{i(\omega t - \beta z - \tau)} \frac{A_y \cos \alpha \sin \theta}{-A_x \sin \alpha + A_y \cos \alpha \cos \theta}.$$

As illustrated in Figure 2, the receiving antenna is placed in  $z = z_0$ , it is composed of a pair of cross-shaped intersecting vibrators. One vibrator is parallel to the  $x'$  axis and the other is parallel to the  $y'$  axis, the feeder of the vibrator parallel to the  $x'$  axis is either shorter or longer ( $\Delta l$ ) than the feeder of the vibrator parallel to the  $y'$  axis, thus the induced voltage on the feeder at  $z = z_0$  is:

$$V_x = K_x E_x e^{-j\beta(\pm \Delta l)}, \quad V_y = K_y E_y. \quad (3)$$

$K_x$  and  $K_y$  are coefficients. It is not hard to obtain the voltage of load  $Z_L^x$  of the equivalent circuit drawn at this point. According to Kirchhoff's theorem

$$|V| = \frac{K_0}{2 + R/R_L} \{A_x^2 + A_y^2 + 2[-A_x^2 \sin \alpha \cos \alpha + A_x A_y \cos 2\alpha \cos \theta + A_y^2 \sin \alpha \cos \alpha] \cos(\beta \Delta l) \mp 2A_x A_y \sin \theta \sin(\beta \Delta l)\}^{1/2}. \quad (4)$$

Now, if we assume that the impedance  $Z_{x'}$  and  $Z_{y'}$  of the two vibrators is the same and match it with the impedance of the transmission line, i.e.,  $Z_{x'} = Z_{y'} = R$ ,  $Z_L = R_L$ , and let  $K_x = K_y = K$ .

Eq. (4) is the voltage obtained for any elliptical polarized wave as transmitting and the cross-shaped intersecting vibrators of any elliptical polarized wave as receiving antennas. From the reciprocity theorem we know that if we make cross-shaped intersecting vibrators as the transmitting antenna and the other elliptical polarized wave antenna as the receiving antenna, the voltage received will be the same. When  $0 < \beta \Delta l < \pi$ , the  $-z$  direction of Figure 2 is the transmission wave propagation direction. In Eq. (3) in the exponential brackets, (+) is taken as a right-hand circular wave and (-) as a left-hand circular wave. If we transmit a right-hand circular polarized wave, then

$\Delta l = \frac{\pi}{2}$ . If (+) is taken in the brackets in Eq. (3), then correspondingly (-) is taken in Eq. (4), then we have

$$|V|_R^2 = \left| \frac{K_0}{2 + R/R_L} \right|^2 \{A_x^2 + A_y^2 - 2A_x A_y \sin \theta\}. \quad (5)$$

$|V|_{Rc}^2$  is the strength of the signal received when the transmitting wave is right-hand circular polarized and the receiving antenna is elliptically polarized in any direction.

By the same token, if the transmitting antenna transmits left-hand circular polarized waves, then Eq. (4) correspondingly should taken the (+) below, thus we have:

$$|V|_{Lc}^2 = \left| \frac{K_0}{2 + R/R_L} \right|^2 \{A_x^2 + A_y^2 + 2A_x A_y \sin \theta\}. \quad (6)$$

$|V|_{Lc}^2$  is the strength of the signal received when the transmitting wave is right-hand circular polarized and is received as a polarized wave of any rotation.

Adding Eqs. (5) and (6) together, for any polarized receiving antenna (the measured antenna) we have:

$$|V|_c^2 = |V|_{Rc}^2 + |V|_{Lc}^2 = \left| \frac{K_0}{2 + R/R_L} \right|^2 \{A_x^2(\theta, \varphi) + A_y^2(\theta, \varphi)\}. \quad (7)$$

and this is the directional map of the measured antenna. This is identical to the results obtained by the method of measuring the horizontal polarized component and then measuring the vertical polarized component.

From Figure 1 and Eq. (1) it can be seen that when  $0 < \theta < \pi$ , the +z axis is the radiation wave propagation direction and the measured antenna radiation left-hand wave,  $\sin \theta > 0$ , from Eqs. (5) and (6) we get:

$$\begin{aligned} |V|_{Lc-L}^2 &= \left| \frac{K_0}{2 + R/R_L} \right|^2 \{A_x^2 + A_y^2 + 2A_x A_y \sin \theta\} \\ &> \left| \frac{K_0}{2 + R/R_L} \right|^2 \{A_x^2 + A_y^2 - 2A_x A_y \sin \theta\} = |V|_{Rc-L}^2 \end{aligned} \quad (8)$$

in which  $|V|_{Lc(Rc)-r}^2$  is the strength of the signal received when the left-hand (right-hand) circular polarized wave is transmission and the left-hand elliptical polarized wave is reception.

By the same token, when  $-\pi < \theta < 0$ , for the right-hand elliptical polarized wave,  $\sin \theta < 0$ , then

$$|V|_{Lc-R}^2 > |V|_{Rc-R}^2 \quad (9)$$

in which  $|V|_{\text{Rc(Lc)-R}}^2$  is the strength of the signal received when the right-hand (left-hand) circular polarized wave is the transmission and the right-hand elliptical polarized wave is the reception.

In this way, the rotation of the measured antenna is determined entirely by the strength of a signal of any rotation received when receiving the circular polarization of the transmitting antenna.

2. Measurement of the polarized elliptical axial ratio of the measured antenna. We know that when the polarized elliptical primary axis coincides with the  $x'$  axis and the  $y'$  axis,  $E_x'$  and  $E_y'$  is the length axis of the ellipse, and the axial ratio formula is<sup>[4]</sup>:

$$r = \frac{E_x'}{E_y'} = \frac{2A_x A_y \sin \theta}{A_x^2 + A_y^2 \pm \sqrt{(A_x^2 + A_y^2)^2 - 4A_x^2 A_y^2 \sin^2 \theta}} \quad (10)$$

let

$$K = \frac{2A_x A_y \sin \theta}{A_x^2 + A_y^2}, \quad 0 \leq K < 1,$$

then 
$$r = \frac{K}{1 \pm \sqrt{1 - K^2}} \quad (11)$$

If we take  $0 \leq r \leq 1$  as  $r$ 's scope of change, then we have

$$r = \frac{K}{1 + \sqrt{1 - K^2}} \quad (12)$$

when  $0 < \theta < \pi$ , from Eq. (8) we see:

$$P_{\text{Lc-L}} \propto A_x^2 + A_y^2 + 2A_x A_y \sin \theta, \quad P_{\text{Rc-L}} \propto A_x^2 + A_y^2 - 2A_x A_y \sin \theta.$$

$P_{\text{Lc(Rc)-L}}$  represents the power received when the left-hand (right-hand) circular polarized wave is the transmission wave and the left-hand elliptical polarized wave antenna is reception.

$$K = \frac{P_{\text{Lc-L}} - P_{\text{Rc-L}}}{P_{\text{Lc-L}} + P_{\text{Rc-L}}} = \frac{2A_x A_y \sin \theta}{A_x^2 + A_y^2} \quad (13)$$

For  $-\pi < \theta < 0$ , similarly we can obtain Eq. (13) (as long as we let  $\theta' = -\theta$ ).  $P_{\text{Lc-L}}$ ,  $P_{\text{Rc-L}}$ ,  $P_{\text{Rc-R}}$  and  $P_{\text{Lc-R}}$  were actually measures therefore through Eqs. (11) and (13) we can compute  $r$ .

The deduction of the above formulas is based on document [5] and is only slightly augmented to suit our goal. Although the model we propose is simple, it is suited to any type of antenna. It is just as universal as the polarization loss formula they deduced.

3. Error analysis. All the above formulas were derived under the conditions where the axial ratio  $r_t$  of the transmitting antenna is 1. But actually,  $r_t$  can not really be 1, but is always less than that, though close to 1. It can be proven that when the transmitting antenna's axial ratio  $r_t > 0.9$ , the measurement error of the directional map and the measurement error of the circular polarized antenna axial ratio are both within the permissible range.

If the transmitting antenna's axial ratio  $r_t$  is less than 1 but close to 1, and the transmission right-hand and left-hand polarization time is equal then  $r_R = r_L$ ; and supposing the left-hand polarization time and the long axis of the polarized ellipse coincide with the transmission right-hand direction; without losing universality, supposing  $A_x = A_y = A$ ; and supposing  $\beta\Delta l = \frac{\pi}{2} \pm \delta$ ,  $\delta$  is a small quantity; then from Eq. (7) we get:

$$P_c \propto |V|^2 = \left( \frac{2KA}{2 + R/R_L} \right)^2$$

in which  $P_c$  is the energy received by the receiving antenna when the transmission antenna is not an elliptical polarized wave of  $r_t = 1$ .

$$10 \log_{10} \frac{P_c'}{P_c} = 10 \log_{10} (1 \mp \cos 2\alpha \cos \theta \sin \delta) \approx \mp 4.34 \cos 2\alpha \cos \theta \sin \delta, \quad (14)$$

in which  $P_c$  is the energy received by the receiving antenna when the circular polarized wave acts as the transmission. From Eq. (14) and Figure 3 it can be seen that if the measured antenna is circular polarized, i.e.  $\cos \theta = 0$ , then the error is small. When the transmitting antenna's axial ratio is 0.9, the maximum measurement error of the linear polarized antenna is  $\pm 0.46$ dB.

It can be proven that as long as the transmitting antenna's axial ratio  $r_t > 0.9$ , the measurement error of the measured antenna's axial ratio can be less than 1dB. Under assumptions similar to those above, if

$$\varphi' = \beta\Delta l = \frac{\pi}{2} \pm \delta,$$

then

$$r(\varphi') = r\left(\frac{\pi}{2}\right) \pm \frac{dr(\varphi')}{d\varphi'} \Big|_{\varphi'=\frac{\pi}{2}} \cdot \delta,$$

$$\frac{r(\varphi')}{r\left(\frac{\pi}{2}\right)} = 1 \pm \frac{1}{r\left(\frac{\pi}{2}\right)} \frac{dr(\varphi')}{d\varphi'} \Big|_{\varphi'=\frac{\pi}{2}} \cdot \delta = 1 \pm \frac{1}{r\left(\frac{\pi}{2}\right)} \frac{dr(K)}{dK} \frac{dK}{d\varphi'} \Big|_{\varphi'=\frac{\pi}{2}} \cdot \delta.$$

It is not hard to see that

$$\frac{dr}{dK} = \frac{1}{(1 + \sqrt{1 - K^2})\sqrt{1 - K^2}},$$

$$K = \frac{\sin \theta \sin \varphi'}{1 + \cos 2\alpha \cos \theta \cos \varphi'},$$

$$\left. \frac{dK}{d\varphi'} \right|_{\varphi' = \frac{\pi}{2}} = \sin \theta \cos \theta \cos 2\alpha,$$

$$\frac{r(\varphi')}{r(\frac{\pi}{2})} = 1 \pm \cos 2\alpha \cdot \delta,$$

Therefore

$$20 \log_{10} \frac{r(\varphi')}{r(\frac{\pi}{2})} = 20 \log_{10} (1 \pm \cos 2\alpha \cdot \delta).$$

(15)

therefore we say that if the measurement error is 1dB, then  $\delta = 6.6^\circ$ , i.e., the transmitting antenna's axial ratio  $r_t = 0.89$ .

### III. Specific Considerations of the Experiment and Experimental Results

In actual measurements, there are some specific questions which must be considered.

1. On the site and the erection of the receiving antenna. First of all the following relationship<sup>[1,2,6]</sup> should be satisfied:

$$4h_t h_r = R\lambda, \quad (16)$$

in which  $h_t$  is the transmitting antenna altitude,  $h_r$  is the receiving antenna altitude,  $R$  is the receiving distance,  $\lambda$  is the free space wave length.  $h_t$  should be greater than  $\lambda$ .

Next, the remote field conditions should be satisfied, i.e.,

$$K_1 = \frac{\lambda R}{D^2} \geq 2, \quad (17)$$

in which  $D$  is the diameter of the measures antenna.

As illustrated in Figure 4, projection angle  $\theta$  should be smaller than the Brewster angle, generally less than  $10^\circ$ , i.e.,

$$\theta = \text{tg}^{-1} \frac{h_t + h_r}{R} \quad (18)$$

The receiving antenna (the antenna being measured) should be aimed at the equivalent phase center of the transmitting antenna [6].

$$h_p = \frac{h_t}{y}, \quad y = \frac{1 + |R_{\perp}|}{1 - |R_{\perp}|} \quad (19)$$

in which,  $h_t$  is the equivalent phase center of the transmitting antenna's vertical polarization;  $|R_{\perp}|$  is the modulus of the vertical polarization time surface reflection coefficient. When the transmission is circular polarized, its phase center is  $\frac{1}{2} h_t$ .

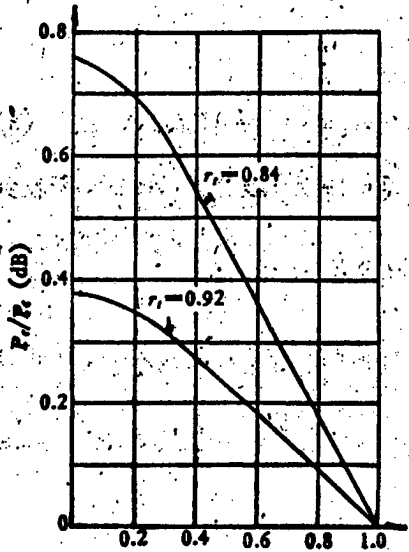

Fig. 3. Relational curve of the receiving power of the antenna being measured and the axial ratio  $r_r$  of the receiving antenna, with the transmitting antenna's axial ratio  $r_t$  as a parameter

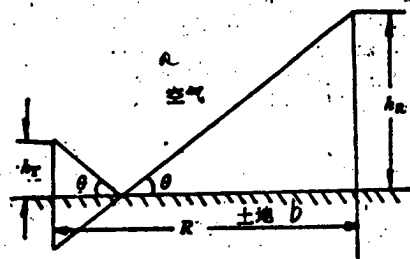

Fig. 4. Geometric relationship of the surface reflection field method's field ground

Key: a: atmosphere  
b: ground

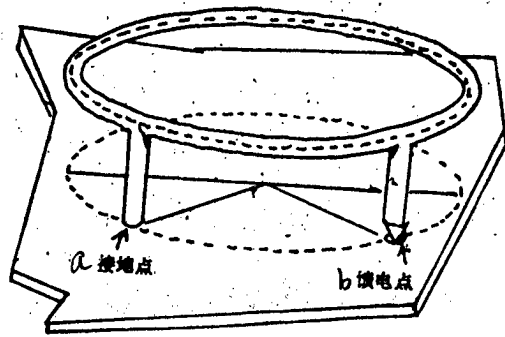

Fig. 5. Geometrical structure of ring-shaped antenna

Key: a. Grounding point  
b. Feeding point

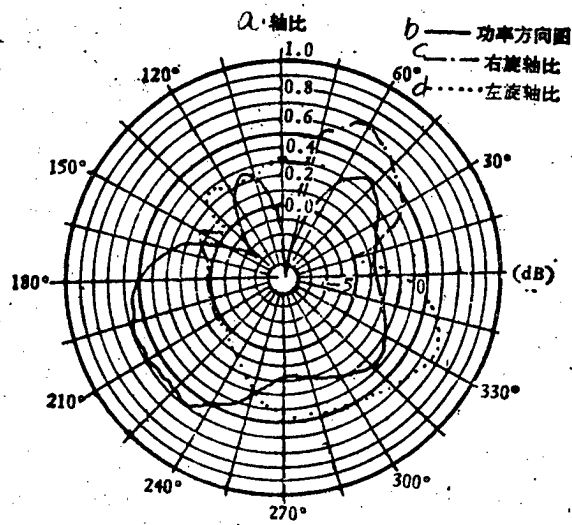

Fig. 6. Directional map at  $\varphi = 67.5^\circ$

Key: a. Axial ratio  
b. Power direction map  
c. Right-hand rotation axial ratio  
d. Left-hand rotation axial ratio

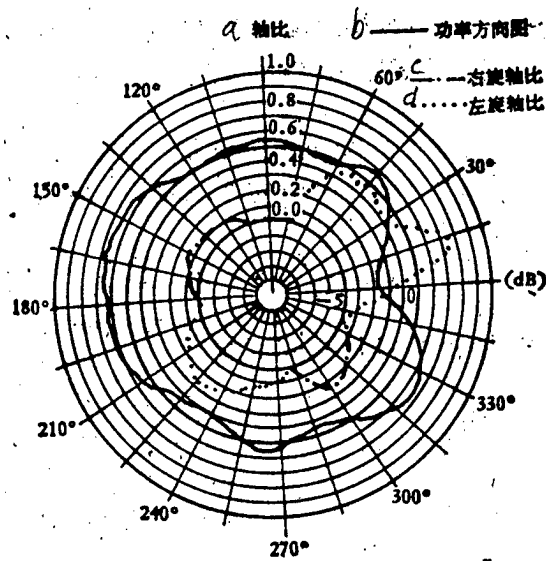

Fig. 7. Directional map at  $\varphi^n = 157.5^\circ$

- Key:
- a. Axial ratio
  - b. Power directional map
  - c. Right-hand rotation axial ratio
  - d. Left-hand rotation axial ratio

2. On the transmitting antenna. Because the surface reflection coefficients of vertical polarization and horizontal polarization are different, when the surface reflection coheres again with the direct waves, the circular polarized waves transmitted by the transmitting terminal are no longer circular polarized waves. Therefore it is necessary to adjust the amplitude and phase of the transmitting antenna so that circular polarized waves of an axial ratio greater than 0.9 will be realized within the diameter of the receiving antenna. We used a bridge to draw out two equal signals with a difference of  $90^\circ$ , and by suitable adjusting the amplitude and phase in the middle fed them separately to the two cross-shaped intersecting vibrators. Finally, the transmitting antenna's axial ratio above 0.9 measured inside the receiving antenna's diameter was taken as a standard.

3. On measuring the diameter field. Measurement of the receiving antenna's diameter field is a problem related to whether or not it can be used with the field ground and whether or not the characteristics of the antenna being measured can be believed. We use a semi-wave vibrator to probe the measurement field distribution of the three dimensions of the receiving antenna's diameter: above and below, left and right, and front and back. The measurement range was just slightly larger than the diameter of the antenna being measured.

The important factors that influence diameter field distribution are: first, the surface is uneven, second the framework which supports the satellite shell. If the surface is very level and the framework is as simple as possible, then the comparative purity of the diameter field can be guaranteed, of course, the bodies that scatter the electromagnetic field, such as electric cables and trees, should be reduced in the field ground environment.

How large the wave motion in the diameter field should be before it can be used should be determined by measurement error. Generally, when the diameter field wave motion is about 0.5dB measurement of the omnidirection antenna can be carried out. Measurement of the diameter field is illustrated in Table 1.

Table 1 Diameter field wave motion

	Front to back		Horizontal		Up and down	
	Vertical	Horizontal	Vertical	Horizontal	Vertical	Horizontal
Field wave motion 5dB	0.7	0.4	0.3	0.7	0.8	0.8

4. Experimental results. We calculated  $h_t = 6m^*$  [\*actually, due to limiting conditions, we adopted it as 5.3m] according to Eq.. (16) we using  $h_r = 7.6m$ ,  $R = 110 m$ , and  $\lambda = 1.7m$ . We measured the transmitting antenna's axial ratio right-hand rotation as  $r_R = 0.927$ ; left-hand rotation  $r_L = - 0.932$ . Because  $r_R$  and  $r_L$  were different, when processing the data we had to revise it.

Measuring  $|R_{\perp}| = 0.65$ , we calculated  $h_v = 1.12m$ . We carried out measurement tests using the ring-shaped antenna (see Figure 5) scheme presented in document [7]. Partial results of the measurement tests are as illustrated in Figures 6 and 7. This is a meridian plane directional map. The meridian  $\phi'' = 67.5^\circ$  in Figure 6 is the plane through the feeder point, ring center, and satellite shell center given in Figure 5. Figure 7 is the meridian perpendicular to Figure 6.

Table 2 gives the antenna's axis forward power values, i.e., the gain at  $0^\circ$  axis of Figures 6 and 7. It can be seen that the measurement error of the axis forward gain is  $\pm 0.55dB$ . Document [8] points out that the main beam of the omnidirectional antenna on the Apollo flight vehicle has an error of  $\pm 1dB$ . This proves that the standards we chose are rational.

Table 2. Power values of Antenna on Satellite Axis Forward

Measurement surface $\phi''(^{\circ})$	0	22.5	45	67.5	90	112.5	135.	157.5
Axis forward power normalization (dB)	-0.5	0	-0.29	-0.86	-0.92	-0.57	-0.75	-1.11

#### IV. Conclusion

To make the measurements of flight vehicle-mounted omnidirectional antennas, first the measurement field surface should make the diameter field extremely pure. Second, the left and right-hand axial ratio of the transmitting antenna should be as close to 1 as possible. Third, measurement should be automatic and fast.

In this project we received beneficial guidance from assistant researchers Zhang Jingcheng [1728 2529 6134] and Hu Mingru [2073 2494 0320] and some of the data in the paper was compiled by Comrades Gao Xuanzheng [7559 6693 2973], Yi Nianxue [2496 1819 1331], and Guo Wenjia [6753 2429 0857], and I would here like to express my heartfelt thanks.

#### References

1. E.T. Ford, CONFERENCE ON AEROSPACE ANTENNAS, 8-10 June 1971, 89-71.
2. Albert Cohn and A.W. Maltese, THE MICROWAVE JOURNAL, 4 (1961) 57.
3. W.G. Scott and K.W. Soohoo, IEEE TRANS. On Ap. Ap-14 (1966) 587.
4. Lu Baowei [0712 0202 4850] DIANBO CHUANBO [ELECTRIC WAVE PROPAGATION] Zhongguo Keji Daxue Jiangyi [China Science and Technology University Lectures], 1961.
5. W. Sichak and S. Milazoo, PROC. I.R.E. 36 (1948) 997.
6. Zhang Jinbiao [1728 6855 2871], WULI XUEBAO [ACTA PHYSICA], 27 (1978) 526
7. M. Boella, C. Cuigiani, and A. Villa, R. Zich, RADIO ANTENNA FOR AIRCRAFT AND AEROSPACE VEHICLES, AGARD Conference Proceedings, No 15, 321-337.
8. T. Lindsey III and L. Leopold, THE MICROWAVE JOURNAL 12 (1969) 71.

8226

CSO: 5500/4144

PEOPLE'S REPUBLIC OF CHINA

ENCRYPTION METHOD FOR IMAGES DESCRIBED

Beijing TONGXIN XUEBAO [JOURNAL OF CHINA INSTITUTE OF COMMUNICATION] in Chinese Vol 5 No 3, Jul 84 pp 85-90

[Article by Zhang Pingsheng [1728 1456 3932] of Wuxi TV Plant and Bi Houjie [3968 0624 2638] of Nanjing Institute of Posts and Telecommunications]

[Text] Abstract

This paper presents an image encryption method that combines disturbances of pixel addresses with the encryption technology of RSA systems. Under the premise of not increasing the information content of the image, its encryption can be more speedily accomplished. The estimation of the time to break the cryptogram shows that it will take too much time with the aid of available computer technology. This communication method using coded images, regardless of key distribution of encryption information transmitted does not require adoption of secret channels. Thus it is an economical and practical method.

I. Introduction

In November 1976, Drs Martin E. Hellman and Whitfield Diffie proposed in their paper "New Directions in Cryptography,"<sup>1</sup> for the first time a system of secret coding for communication via public key channels. In this system, each user keeps a pair of encrypt code (public key) and decoding keys (secret key code), so that it is almost impossible for an illegal interceptor to solve the message from public key code. All users can distribute this encrypting code openly and let the corresponding side encrypt messages for transmission.

In February 1978, Drs R.L. Rivest, A. Shamir and L. Adleman of the United States published "A Method for Obtaining Digital Signatures and Public Key Crypto-system"<sup>2</sup> in which they proposed a mathematical model to facilitate secret correspondence via public key. This is what Dr Hellman called "RSA public key code secret code system," which makes digital signature with distribution of secret code over open channels possible. It is very difficult and takes a very long time to decipher secret messages. It is therefore

superior to the sectionalized encryption with conventional secret key system.

RSA system calls for large amounts of calculation in encryption and deciphering. Evidently it is not possible to employ this technology to encrypt huge amounts of image signals (element) directly. Here in this writing, it is proposed to retain the advantages of RSA system's encryption method (open distribution of encrypting code, digital signature and difficulty to break the cryptogram), but in the meantime does not increase the volume of image signals, so that it is relatively fast to encrypt, and the encryption itself will not introduce diffusion of coding errors. It is suitable for secret image transmission in military, diplomatic and intelligence organizations.

## II. RSA Public Key Encryption System

Block diagram Figure 1 illustrates the structure of public key code encryption system. In it,  $M$  represents public key code,  $C$  represents secret code, and  $\hat{M}$  is the erroneous message as solved by the analyst. According to RSA system, encrypting code  $(e, n)$  can be transmitted through public channels to instruct the sender how to encrypt messages, but decoding keys  $(d, n)$  prepared alongside with  $(e, n)$  are kept in secrecy by the users.  $E(M)$  is used to represent the encryption of public code ( $M$ ), and  $D(C)$  to represent the decoding of secret code ( $C$ ). Set  $0 < M < n$ ,  $0 < e < \varphi(n)$  (where  $\varphi(n)$  is the Euler number and is expressed as less than  $n$ , and is a single digit positive integer relatively prime to  $n$ ),  $0 < d < \varphi(n)$ , also  $M$ ,  $n$ ,  $e$ , and  $d$  are all integers.

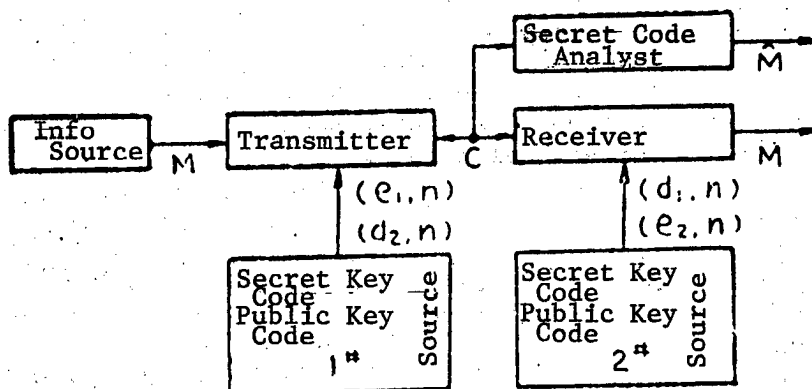

Figure 1. Block Diagram of Public Key Code Encryption

According to the theory of numbers, the theoretical definition of RSA system can be shown as

$$C \equiv E(M) \equiv M^e \pmod{n} \quad (1)$$

If the only decoding key  $(d, n)$  can be found, so that

$$M \equiv D(C) \equiv C^d \pmod{n} \quad (2)$$

becomes valid. Then the reciprocal process of decoding and encryption can be accomplished.

Let,  $n = p \cdot q$  ( $p, q$  are both huge and randomly picked prime numbers)

From Eulerian theory, when

$$\begin{aligned} M^{\varphi(n)} &\equiv 1 \pmod{n} \text{ (where } M, n \text{ are relatively primed)} \\ \varphi(n) &= (p-1)(q-1) = n - (p+q) + 1 \end{aligned} \quad (3)$$

Any randomly picked  $e$ , and let  $0 < e < \varphi(n)$ , and  $e$  is relatively prime to  $\varphi(n)$ , by the linear congruence induction,<sup>3</sup> it is possible to get one, but only one, "d" smaller than  $\varphi(n)$  to satisfy

$$e \cdot d \equiv 1 \pmod{\varphi(n)}$$

The above can also be expressed as:

$$e \cdot d = k \cdot \varphi(n) + 1 \text{ (k is a certain positive integer)} \quad (4)$$

solving (3) and (4), we get

$$M^{e \cdot d} \equiv M^{k \cdot \varphi(n) + 1} \equiv (M^{\varphi(n)})^k \cdot M \equiv 1 \cdot M \equiv M \pmod{n} \quad (5)$$

Establishing formula (5) assures the simultaneous existence of (1) and (2), and

$$D(E(M)) \equiv E(D(M)) \equiv M \pmod{n} \quad (6)$$

Formula (6) explains the encryption of public code  $M$  with  $(e, n)$ , followed by decoding with  $(d, n)$  will arrive at the same result of public code  $M$  as if it is first encrypted with  $(d, n)$  and then decoded with  $(e, n)$ . Since  $d$  is kept in secret, using  $(d, n)$  to encrypt the message, that embodied the signature, has the function of digital signature, so that a receiver can verify its authenticity, and not sent by anyone else (counterfeiter).

The RSA system is built on the basis that it is not difficult to search for two huge prime numbers, but is very difficult to break down their product. There are a number of methods to decode the RSA system, all by means of factorizing  $n$  to get  $p$  and  $q$ , from which  $\varphi(n)$  can be found, and solve  $d$  from  $e$ . The methods to factorize  $n$  are: (1) direct factorization of  $n$ ; (2) search for  $d$  and factorize  $n$ ; (3) search for  $\varphi(n)$  to factorize  $n$ .<sup>2</sup> The latter two methods require about the same amount of calculation as that of the first method. Time required for direct factorizations of various digit lengths  $n$  is listed in Table 1<sup>2</sup>:

Table 1. Time To Break n, and Its Relation to the Number of n Digits

n Digits	Number of Computer Operations	Break Time*
50	$1.4 \times 10^{10}$	3.9 hours
75	$9.0 \times 10^{12}$	104 days
100	$2.3 \times 10^{15}$	74 years
200	$1.2 \times 10^{23}$	$3.8 \times 10^0$ years
300	$1.5 \times 10^{29}$	$4.9 \times 10^{15}$ years
500	$1.3 \times 10^{39}$	$4.2 \times 10^{25}$ years

(\*Time needed for a computer to operate at  $10^6$ /sec to break)

When p and q are both 50 digits long and both are random prime numbers, to decode this RSA encryption in reality is very difficult.

Michel O. Rabin of the Hebrew University in Jerusalem, Israel,<sup>4</sup> studied the improved model of RSA system (E=2) and said that it has the same degree of crypto-analytic difficulty as that of direct factoring the n-mode. Although RSA system has not strictly proven the degree of difficulty solve the E=1 encryption, but in the general sense the search for d or  $\varphi(n)$  calls for an amount of calculation not less than that of direct factorization of n, hence it could be taken that the amount of time shown in Table 1 equals approximately to that of the analysis of the secret code.

According to the mathematical theory of RSA system, the authors compiled a computerized encryption and decoding (including digital signature) program; using a  $3 \times 10^5$ /sec. computer FACOM-230-38 to encrypt the telegram shown in Figure 2 (including digital signature), the result is shown in Figure 3.

To encrypt open code, one uses public key code ( $e_1, n$ ). The third group is re-encrypted once more with secret code ( $d_2, n$ ) to achieve the function of digital signature.

One can use secret key code ( $d_1, n$ ) to solve the secret coded message. But for the third group, it should be decoded once more with public key code ( $e_2, n$ ) to recover the original plain code message. The example is successful, where

n=2760 6698 5387 1622 5514 9739 0234 4910 7931 6684 5871 6142 6206 0116  
 9954 8030 0080 3329  
 $e_1 = 817263426261718292019172641325$   
 $d_1 = 8010177069151716031712825841034692308201199845709577935218762363351649$   
 $e_2 = 1163426109612335781098341523579873$   
 $d_2 = 8519349739417798493137072943053039143300643844785862400000652603350889$

	定	于	12月	1日	至	12月	15日	在	南	京	举
0000	1353	2456	9712	9901	5267	9712	9915	0961	0589	0079	5282
	行	保	密	通	信	体	(Group I message)				
5887	0202	1378	6639	0207	7555						
	制	的	讨	论	会	。	希	你	暂	将	在
0000	0455	4104	6062	6158	2585	9975	1585	0132	2548	1412	0961
	京	的	研	究	工	作	(Group II message)				
0079	4104	4282	4496	1562	0155						
	交	托	他	人	员	责	，	乘	乙	机	来
0000	0074	2094	0106	0086	6298	6307	9976	0042	7378	2894	0171
	宁	。	6	3	所	。	(Group III message)				
1337	9975	9966	9963	2076	9975						

Figure 2 Public Code Telegram Text

0066	9959	0871	6800	6320	7687	6554	2795	6729	0869	0823	6721
	况	曠	酷	贺	夸	软	棍	邳	嗽	喜	邦
8066	7585	7356	5339	8014	6974	(Group I secret code message)					
	弃	管	顿	瓦	鏖						
0269	5935	9542	3798	2548	7858	9590	9616	5991	9228	3574	5953
	徕	程	玳	暂	畿		碱	裆	罅	熊	裸
4030	1285	9042	5039	9509	1899	(Group II secret code message)					
	捕	嫫	簏	科	炒	闷					
0239	4368	0683	7630	1131	6071	2081	1436	6206	6419	7814	9789
	倦	祐	后	鮎	天	池	辰	解	谩	跡	浴
3620	5424	0761	2447	6902	9515	(Group III secret code message)					
	烂	萄	哈	斩	銜	瑟					

Figure 3 Secret Code Telegram Text

Using public key code (e,n) to encrypt one section of message takes about an average of 26 seconds, and to solve it with secret key code (d,n) takes an average interval of about 67 seconds. Because the binary number of d has a length more than twice as long as that of e.

Originators of RSA system claimed that it takes only a few seconds to encrypt a message M with a 200 digit number, on a high-speed computer. According to the program compiled by the author can be encrypted as a 72 digit integer because of the fact that number n is already longer than 68 digits and operation number of digits is increased by increments of 4 digits. If it is run on a high-speed machine (say  $10^6$ /sec.), it will need 26 seconds  $\times 30/1000 = 0.78$  seconds. The increase of time for encryption is slightly

larger than the square of the ratio of increase of message lengths. Using this program and working on a high-speed computer ( $10^7$  times/second), to encrypt a 200 digit signal takes about 0.78 sec.  $\times (200/72)^2 = 6$  sec. This is almost the same as the standard encryption time for RSA system.

Obviously, RSA system is completely suitable for the software encryption of telegraphic code, which has significant importance in application to the secret telegrams.

### III. Image Encryption

As mentioned in the introduction, to encrypt the tremendous amount of image signals directly with RSA system is not practical. How to apply their merit to image encryption? This author designed a way to scramble the column address twice to form two digital and random numbered columns  $\{R_i\}$  and  $\{S_i\}$ . Using this  $\{R_i\}$  and  $\{S_i\}$  to scramble the addresses of a frame of image, the encrypted image is obtained. Meanwhile, using RSA system's encrypt technique,  $\{R_i\}$  and  $\{S_i\}$  are encrypted to get  $\{R'_i\}$  and  $\{S'_i\}$ . The sender transmits  $\{R'_i\}$  and  $\{S'_i\}$  via public channels to the receiver, and only the receiver can use the secret key code to decipher  $\{R'_i\}$  and  $\{S'_i\}$ .

Provided that an image consists of 256 x 256 elements,  $\{R_i\} = R_1R_2R_3\cdots R_i\cdots R_{256} = 007060131\cdots 207\cdots 035$ ,  $\{S_i\} = S_1S_2S_3\cdots S_i\cdots S_{256} = 063105035\cdots 001\cdots 056$ . With  $\{R_i\}$  and  $\{S_i\}$ , addresses can be scrambled in three steps:

Step one: Cyclically shift the horizontal line elements according to the random number. For instance,  $R_i = 207$  means that all elements of the original line address  $(i,207)$  is to be shifted to a new line address of  $(i,1)$ , and other elements on this line  $i$  are to be shifted in sequence, the result will be image A (A is a low level encrypted image).

Step two: Randomly scramble columns. For instance,  $S_i = 063$ , means all elements in column 63 of image A remain in their line address, but are transferred to column 1. The result image after the transport of column addresses of image A is image B (image B is an image of relatively high degree of secrecy).

Step three: Randomly transposition columns elements in sequence. For instance,  $R_i = 207$  meaning that all elements with address  $(207,i)$  of image B undergo transport to  $(1,i)$  columnwise, so are the other elements on this column  $i$  be transported in sequence columnwise. Elements of every column of image B, after randomly transferred cyclically, a desired image encryption is thus arrived at as image C (C is a highly secret form of image).

Encrypted image C has a set of elements with their relative positions entirely different from the elements of the original. For those without knowledge of  $\{R_i\}$  and  $\{S_i\}$  values, every element of the original image can be considered to have left their original position and randomly fallen onto a new position, so that it is an image of high secrecy.

The first and third steps of the three-step scrambling can be done instantly with hardware circuitry, and no extra encryption time is required. The second step also does not require encryption time, but the entire image signals must be stored in the memory before they are on-time retrieved according to the random order designated by  $\{S_i\}$ , for different columns of elements of image A. Therefore, the time to encrypt a single frame is the time spent to store a complete frame of image A. The authors have successfully designed a portion of the hardware for the control of signals that directs the scrambling and shifting.

During the encryption of an image, the density of every element is not modified (therefore the statistical rectangular diagram is also unchanged); only the addresses are changed so that the signal quantity will not be increased.

$\{R_i\}$  and  $\{S_i\}$  are not sent to the receiver by direct transmission, but only the  $\{R_i'\}$  and  $\{S_i'\}$  are transmitted; the receiver can solve for  $\{R_i\}$  and  $\{S_i\}$  from  $\{R_i'\}$  and  $\{S_i'\}$  by using the RSA technic. Henceforth the merits of RSA system (public key code (e,d) being distributed openly and realization of digital signature) are preserved intact.

Decoding of the image is the reverse of the encryption process. The block diagram in Figure 4 illustrates these processes.

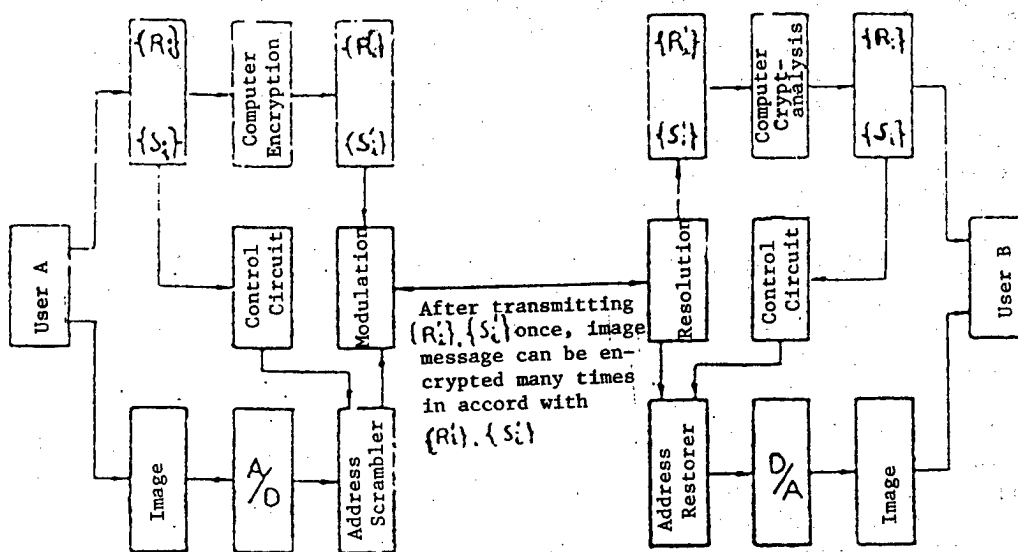
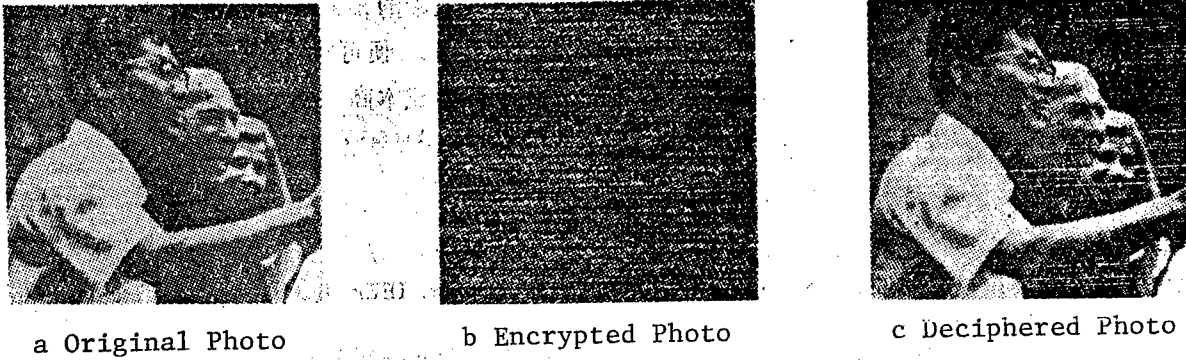

Figure 4. Block Diagram of Image Encryption System

The authors, utilizing the image-system of a Z80 microprocessor, encrypted an original three-person photo with the above-mentioned method. The result is an encrypted image of spotty and scattered ensemble. After decoding, the original equivalent is recovered as shown in Figure 5.



a Original Photo                      b Encrypted Photo                      c Deciphered Photo

Figure 5 Original, Encrypted, and Deciphered Pictures

The encrypted image shows a field of evenly distributed scattering spots. The relative properties of the elements in the original is actually non-existent.

There are two comparatively good methods to analyze the encrypted image:

1. Using crypto-analysis of  $\{R_i\}$  and  $\{S_i\}$  within the RSA system. It is impossible to solve secret key code  $(d,n)$  from public key code  $(e,n)$ , then again using  $(d,n)$  to convert  $\{R_i\}$  and  $\{S_i\}$  into the original  $\{R_i\}$  and  $\{S_i\}$ .
2. Using screen display method to restore a certain original image. It is further impossible to solve for  $\{R_i\}$  and  $\{S_i\}$ . Because the relative properties of individual elements have been completely lost, and  $\{R_i\}$  and  $\{S_i\}$  are arranged randomly; even if the analyst knows the scrambling process in detail, the best he can do is to search among all of their possible arrangements for  $\{R_i\}$  and  $\{S_i\}$  in order to be able to decode the signals. The amount of searching work is prohibitive, for a  $256 \times 256$  format, the possible arrangement is of the order of  $A_{256}^{256} = 256!$  each, reaching a total of  $A_{256}^{256} \times A_{256}^{256} = (256!)^2 \approx 2.670384627 \times 10^{1009}$ .

Suppose it takes 1 minute to store one frame of image elements for every change of address, the maximum searching time will be  $5.08064 \times 10^{1003}$  years, even the average will still be  $2.54032 \times 10^{1003}$  years, an astronomical figure indeed.

The duration to employ a certain set of  $\{R_i\}$  and  $\{S_i\}$  for secret image transmission can be rather flexible. To prevent it from being attacked by (comparing with) known messages,  $\{R_i\}$  and  $\{S_i\}$  can be changed after using for a certain period of time. It has been mentioned that a frame of  $256 \times 256$  element square image has  $(256!)^2$  or  $2.670384627 \times 10^{1009}$  number of  $\{R_i\}$  and  $\{S_i\}$  combinations, so that it is ample enough for practical use in encrypt-image communication. If the  $\{R_i\}$  and  $\{S_i\}$  pair is to be changed 10 times every year, and without repetition, it can last  $2.670384627 \times 10^{1008}$  years. For extremely secret image,  $\{R_i\}$  and  $\{S_i\}$  pair can be changed right after each usage. But generally speaking,  $\{R_i\}$  and  $\{S_i\}$ , once ascertained, can be used many times. For hardware circuitry,  $\{R_i\}$  and  $\{S_i\}$  should be converted into binary form and stored into EPROM, where they can be easily erased and changed.

Three separate units can be built to perform the three stepped address scrambling. They can be employed separately or jointly as deemed necessary. It is rather flexible and convenient. Selection of hardware components can be determined by the different transmission speed of image transmission.

#### IV. Discussions

##### 1. Transmission Problems of $\{R_i'\}$ and $\{S_i'\}$

During the transmission of  $\{R_i'\}$  and  $\{S_i'\}$  erroneous code could be introduced by the noise interference in the transmission channel. It hampers the solution of  $\{R_i\}$  and  $\{S_i\}$  by the receiver a great deal. Steps are necessary to correct the error codes. For instance, due to the duration of  $\{R_i'\}$  and  $\{S_i'\}$  transmission is very short, they can be transmitted repeatedly. For correction of  $\{R_i'\}$  and  $\{S_i'\}$  plain Chinese code can be used. It can also be done by using the telegraphic machine to convert the digital numbers of  $\{R_i'\}$  and  $\{S_i'\}$  into ASC [II] code [?].

##### 2. Transmission Problems of Encrypted Image Signals

Due to the message channel's noise interference, erroneous signals could be introduced into the encrypted image message in the course of transmission. Since the encrypting method changes only the addresses of the elements, their density remains the same, so that errors will not spread. If the message signals were treated with DPCM [differential pulse-code modulation] before encryption, then the erroneous code will spread, not because of the encryption but due to the DPCM.

##### 3. Examples of Application

(1) For secret code telegrams; encryption of the plain code is done by the RSA system in software, followed by the conversion of digital number into ASC [II] code [?] and transmitted over the regular telegraphic office to the receiver. Therefore ordinary post offices can handle this kind of encrypted telegram as an additional service. The sender gives the software encrypted message to the post office, where neither the dispatcher nor the receiving-operator (of the post office) can gain any knowledge of the actual contents; except that the receiver with the proper knowledge for de-encryption can solve it.

(2) Still-image application: Facsimile, freeze TV images (i.e. transmission of one frame of TV image every minute), can be encrypted with the methods discussed above, using the three-step scrambling of the three continuous units of address scrambler. For facsimile, the original can be encrypted by means of microprocessor before being transmitted. The time consumed may be slightly longer than that with hardware circuitry, but it still has its practical value.

(3) Application in moving images: In foreign countries, secret TV does not destroy the relative properties of image elements, it is used primarily

in satellite transmission and cable TV. Address scrambling using the first step (or the third step) by the address scrambler is sufficient for those TV messages that do not demand high secrecy. It can be done by two sets of address scrambler working on alternate frames of pictures with higher equipment investment, but the encrypted TV is difficult to be decoded. It fits into military, intelligence organizations that have special requirements.

#### REFERENCES

1. Diffie, W. and Hellman, M.E., "New Directions in Cryptography," IEEE TRANS. INFORM. THEORY, Vol IT-22, November 1976 pp 644-654.
2. Rivest, R.L., Shamir, A. and Adleman, L., "A Method for Obtaining Digital Signatures and Public Key Cryptosystems," COMMUN. ACM, Vol 21 No 2, February 1978 pp 120-126.
3. Dudley, U., "Elementary Number Theory," translated by Zhou Zhongliang, Shanghai Scientific and Technical Documents Publishing House, 1980 p 40.
4. Diffie, W. and Hellman, M.E., "Privacy and Authentication; An Introduction to Cryptography," PROC. IEEE, Vol 67 No 3, March 1979 pp 397-427.

(Received 23 June 1982)

12804

CSO: 5500/4158

PEOPLE'S REPUBLIC OF CHINA

BRIEFS

LARGEST TELECOMMUNICATIONS PROJECT COMPLETED--Shanghai, 20 Jun (ZHONGGUO XINWEN SHE)--The telecommunications project which links the Baoshan iron and steel complex to other parts of Shanghai was completed recently. The project cost some 20 million yuan and is the largest local telephone communications project in the Shanghai area. This project includes the laying of a 48-kilometer-long communications pipeline and various communications cables with a total length of 450 kilometers, as well as the erection of 940 wire poles. Automatic and digital controlled telephone exchanges will be adopted in this communications system, and advanced pulse circuits will be imported from abroad and installed in this project. The completion of this project will improve the communications conditions between the Baoshan iron and steel complex and Shanghai urban areas, so it is of great importance for the further development of the northern part of Shanghai. It will also allow the Baoshan iron and steel complex to have access to domestic and international automatic long distance telephone facilities. [Text] [Beijing ZHONGGUO XINWEN SHE in Chinese 0655 GMT 20 Jun 85 HK]

TELECOMMUNICATIONS COMMITTEES SET UP--Qingdao, 17 Jun (XINHUA)--Two specialized committees--the Committee of Electronics Industry and Telecommunications Science and Technology, and the Committee of Radio and Television Science and Technology--were established in Qingdao yesterday. These two committees are institutions organized by the Ministry of Electronics Industry and will carry out scientific and technological research and provide consultative services. They will take part in making major decisions on scientific and technological development as well as in industrial construction projects in their special area; provide consultative services to the nation's special economic zones, open cities, and areas where electronics industry is undeveloped with regard to development of telecommunications, radio, and television services; offer advisory services on importing advanced foreign technology, construction of major projects, and carrying out scientific and technological cooperation with other countries; examine and appraise important new products and results of major systems, engineering and research projects; and recommend outstanding scientists and technicians to departments concerned. The two committees are made up of 112 experts, professors, engineers, and senior engineers of over 60 enterprises, institutions, and schools of higher education in the country. [By Yin Jianhua] [Text] [Beijing XINHUA Domestic Service in Chinese 1501 GMT 17 Jun 85 OW]

FIRST MOBILE FIELD SATELLITE STATION DEVELOPED--China has successfully developed its first [words indistinct] vehicle-carried satellite ground station which can

1 August 1985

be used in field communication. This mobile ground station has attained an advanced technical level. It communicated through satellite with another ground station on the afternoon of 17 June. [Text] [Beijing Domestic Service in Mandarin 1200 GMT 17 Jun 85 OW]

NEW BROADCASTING STATION IN LIAONING--The Panjin People's Broadcasting Station in Liaoning Province began trial transmission on 23 May with the approval of higher authorities. The frequency of the station is 1314 khz. [Excerpt] [Shenyang Liaoning Provincial Service in Mandarin 1030 GMT 23 May 85 SK]

CSO: 5500/4146

## HIGH TECH STRIDE IN COMMUNICATIONS REPORTED

Tokyo NYU MEDIA in Japanese No 2 Feb 85 pp 11-17

[Text] The Fast-Rising Korean Telecom Business Will Not Simply Overtake Japan But Will Surpass It

## Birth of DACOM

A "second electronics" has already been established in Korea. With the support of the presidential group and the Communications Sector (MOC = Ministry of Communications) behind the development of the Korean telecommunications industry, the KTA (Korean Telecommunications Authority) is presently serving as the lone common carrier. This KTA was only formed on December 10, 1981.

The revision of the telecommunications law, enacted in December 1961, which is the basis for the actual separation of the telecommunications administration from the operations system, stopped at a limited level. Nonetheless, the KTA retains a "liberated" administrative function and is a business administration in a liberated state and, since 1982, the move to conduct administrative and business in a clearly defined manner by revamping the telecommunications law and the public communications law has been underway. Then the position of the KTA and the "Second telecommunications" in the form of the Data Communications Corp. of Korea (DACOM) was defined. It needs to be cautioned here that it was in March 1983 that DACOM was born--during the regime of the old law. Under Article 54 of this law which states that it is possible "to appoint special foreigners in exceptional positions," it has assumed a "democratized" form. However, one third of the company belongs to KTA and two thirds are taken up by a total of 26 companies representing various national KBS and other industrial work groups. The DACOM, which was a data communications recovery service of half government-half private workers, became, with the 1984 revamping law, an "avowed" form for advancing individual rights. Its office is separate from KTA and it is taking up space in the Korean National Securities Building. Its capitalization is set at 12 billion yen and it hires 320 workers. Its roster will swell to over 600 names in 1985 to nearly double its present capacity.

DACOM does not have any circuits of its own and cannot be properly called a "second telecommunications system" but it seems to be studying the acquisition of its own data communications lines in the future. At the present time, it is functioning as a KTA line utilizer in the form of a

repurchasing communications enterpriser, but participation in this area is limited, and this is seen to lead only to a 4- to 5-year participation by DACOM.

#### Korea's VT--Chollian

The main bosses of DACOM along administrative lines are KTA and KBS. KBS is equivalent to the Japanese NHK. On the other hand, KBS passes through CM. Although the Korean radio and television advertisements do not all pass through the Korean Broadcasting and Recording Company, the electrowave medium is formally controlled by the nation. On the other hand, there is no dark image, and there is a very light screen through which all information filters through. In the midst of this Korean media situation, DACOM is seeking to function as an important private system in private industry. It was in December of 1980 when the decision to establish DACOM was made. Since being set up in March 1982, it has functioned as a common carrier for data communications. It has been conducting systems introductions necessary to data communications services and related adjustments with foreign countries, and has established a considerable record. Then in July 1984 it set up the public data network for domestic communications. At the international level, the DACOM-NET is connected to the United State and 52 foreign countries.

The principal business items handled can be roughly divided into the following three categories.

- (1) Data transmission service: public data transmission network (DACOM-NET), circuit fees, fiscal information transmission service, electronic mail box service.
- (2) Data handling service: administrative-related soft development projects, automatic information systems, remote computing service.
- (3) Data bank service: overseas DB services, video tech, local DB mechanisms.

The abc's of the data communications system are on the whole covered in these categories, but the above subjects include a number of them. As the culture of human nature is a sharp and urgent problem, one branch is assigned to educational training. At the same time, strength is being placed on the next network formation:

- (1) administrative network
- (2) fiscal network
- (3) educational, research network

What merits particular attention is the video network development.

Already DACOM seems to have decided to make the Korean type of VT a NANPLPS mode. The present system at DACOM are puresuteru (phonetic) but the large manufacturers such as Samsung and KETRI (Korean Electronic Telecommunication Research Institute) are making machines compatible to

(Teridon) on an experimental basis. To be sure CAPTAIN countermeasures are being researched, but no one recognizes that export of hardware systems to Japan is possible and, based on market theory, it may decided to export to North America. To be sure the vast North American market should offer a large "vacuum" for Korean VT exports. No matter what the final mode of selection is for VT the choice has already been made.

Written CHOLLIAN according to the alphabet, it is a very fancy name. It has a harmonius sound. In meaning, it ranks better than CAPTAIN or (teridon). One might come across this brand several years from now in the United States. On the other hand, considerable time will be required for the VT introduction and this VT has not yet been entered in the data service manual for the Seoul Olympics. On the other hand, considerable channel TV service is anticipated, and the occasion may present itself for this source to be mentioned. The Seoul Olympics Organization Committee is supposed to have engaged the news media of Pacific Telex just as did the Los Angeles Olympic Committee. To be sure, this should appeal to the telecom powers of Korea who are busy representing their own.

DACOM is expected to continue to function as a fast-moving data communications service company until the Seoul Olympics gets started.

Complete Automation by 1987

As Korea's Telecom message the total story of KTA is given in the 1983 Annual Report published in July 1984 in the following manner.

"The various countries of the world, in order to prepare for the coming information age are placing all their force into the early resolution of today's ISDN. ISDN will play a great role in Korean society and economics. KTA will put all its effort into the realization of the ISDN concept through the digitalization of the optical fiber network. At the dawn of the day when ISDN is completed, telephone communication will be possible, and data communications, telex, video deck, and video conversation will most likely be possible. By 1987 the entire country will probably be completely automated."

This total account presented the dream of the Korean INS. The effort of all this work is to completefull automation of the entire country by the time the Seoul Olympics rolls around and the later plan of ISDN is to bring about a system to resemble the NTT (Telephone and Telegraph Public Corporation) of the latter half of the 1970s. Now what form of naming will they adopt? Consider Table 1 on the popular rise of the telecom service. The manner in which the speed of service has been achieved each year is clearly revealed.

Table 1. Principal Data for KTA Users

表1 KTAの主要数値

Item	1977	1978	1979	1980	1981	1982	1983
Telephone Capacity Lines Installed	1,666,120	1,997,390	2,426,050	2,834,970	3,491,270	4,492,660	5,337,450
Telephone Subscribers	1,537,139	1,897,263	2,292,686	2,704,504	3,263,322	4,079,590	4,809,897
Applications in Backlog	196,733	418,089	619,195	604,525	497,920	426,991	464,449
Telephone Subscribers per 100 of Population	4.2	5.0	6.3	7.2	8.4	10.4	12.3
Telephone Sets	1,976,051	2,387,336	2,898,687	3,386,800	4,179,721	5,158,357	5,947,536
Public Telephones	31,598	37,615	48,512	56,921	62,025	70,864	88,227
Telegraph Lines	2,600	2,747	3,199	3,232	3,464	5,112	5,145
Telex Lines	2,400	2,900	5,900	5,900	5,900	13,920	13,355
Telex Subscribers	2,321	2,770	3,685	4,318	5,201	6,231	7,539
Long Distance Telephone Transmission Lines	30,399	39,648	50,783	76,749	88,571	123,540	153,063
Domestic Telegram Traffic (Thousand)	42,483	43,241	44,043	42,702	41,571	36,807	36,933
DDD Lines	5,087	10,596	15,653	20,680	26,230	32,971	34,421
Int'l Telecommunication Circuits	701	875	1,083	1,157	1,353	1,480	1,699
Int'l Telegram Traffic (Thousand)	917	821	669	532	496	443	393
Int'l Telephone Traffic (Thousand)	4,604	5,519	6,057	6,759	8,616	10,894	13,024
Int'l Telex Traffic (Thousand)	4,614	6,756	7,839	9,429	11,479	13,910	15,723

\*KTA 1984

Be it DACOM or be it KTA, the determination to emphasize the infra of infra-structure by the 1988 Olympics is evident. Furthermore this independent technology is not the sole resource in attaining this infrastructure, if necessary, Sweden's Ericsson as well as the United State's ITT and WE are being purchased to conduct a multibranch technological approach, one that is surprisingly advanced.

Certainly KTA has been promoting with vigor, in addition to a completely automated dialing system, an annual average of 1 million telephone ownerships, an electronic switchboard system, and a telephone source in every village to expand basic telecom services.

#### The Growing Information Industry

The spirit to overtake Japan is inundating the entire information industry. To be sure, there is still a wide spread between the Koreans and the Japanese, in their leading technologies and applications, but its growth is quickening in tempo.

Although it is the computer which supports the important hardware role in the development of telecom munications, the degree of computer popularization and production of related equipment, and the export situation would make an excellent subject of discussion here.

Production is centered on the four large manufacturers--Kinhoshi, Mihoshi, Toyo Seimitsu and Oaza--who are handling the high tech production system.

First of all, introduction according to computer type and various machine types is shown in Table 2. IBM and VAX (DEC) stand out, as does the encroaching of Fujitsu (FACOM) within the Japanese units. Also note that the industrial world has pushed the others aside where introductory work is concerned. At the same time, the data treatment companies as of 1983 totaled 103 companies. This number slowly increased into the 1980s. There were 6 companies in 1980, 11 in 1981, 8 in 1982 and 35 at the start of 1983. And this number is expected to rise sharply after 1984.

Table 2. Number of Computers Introduced by Manufacturers and Producers  
(As of December 1983)

表2 メーカー・機種別コンピュータ導入数(1983年12月現在)

Manufacturers	Main-frame	Super-mini	Small Business	Mini	Micro	Total
IBM	47	60	61	50	1	219
FACOM	7	14	32	4	-	57
UNIVAC	13	3	21	5	-	42
CYBER	5	8	4	1	3	21
PRIME	-	14	21	21	3	59
VAX (PDP)	-	2	24	36	80	142
NCR	3	3	11	3	18	38
HP	-	1	7	63	7	78
ECLIPSE	-	-	4	28	7	39
Honeywell	-	2	1	13	12	28
BURROUGHS	-	-	2	19	1	22
WANG	-	-	1	5	51	57
NOVA	-	-	-	2	31	33
FOURPHASE	-	2	2	10	10	24
Others	1	5	23	58	168	255
Total	76	114	214	318	392	1,114

\*総務庁 \* General Affairs Agency

While it cannot yet be said that the true computer age has arrived, it is predicted that computers will be rapidly introduced into every phase of work. By the Olympics of 1988, a considerable buildup is expected. Moreover, of the 135,000 personal computers units produced in 1983, 5700 units were exported. In OA equipment, including word processors and printers, the power of the Korean telecom industry is increasing.

Furthermore, although uncertain as to how advertisements, publications, newspapers, and broadcasts relate to the world, I would like to treat this subject in another article.

All for the Benefit of the Olympics

What was it that received a boost at the 1964 Olympics held in Japan.

The Seoul of today is being tailored to the 1988 Olympics to be held there and also to the 1986 Asian meet preceding it in order to "be prepared" to fit precisely into the needs of the time.

One accomplishment the Seoul Olympics can "boast" to the world is the manner in which the telecom business will have developed by then. On part of this can be seen in the Olympic support plan. The details will show that KTA had laid its support plan before the Asian contest of '86 to take effect by the end of 1985. Then a number of modifications would be added for the actual performance. Of course, radio and TV telecasts have taken over most of the systems, and the two large sports broadcasters will probably encircle Korea's national field with a high tech field.

KTA has a total of 42,761 workers and sales of 1.17 trillion won. When the KTA figures of a steadily growing Korea are compared with the NTT figures, they are far smaller but, when the 1988 of a bigger Korea rolls around, what will their relative positions be?

Tabel 3. Number of Computers Introduced According to Type  
(As of December 1983)

表3 コンピュータの分野別導入数 (1983年12月現在)

Sector	Main-frame	Super-mini	Small Business	Mini	Micro	Total
Gov't	10	9	27	13	22	81
Educational, R&D Org.	5	5	31	68	138	247
Financial, Insurance	20	29	32	35	19	135
Industry	41	71	124	202	213	651
Total	76	114	214	318	392	1,114

\*総務庁 \* General Affairs Agency

Fig. 1 Number of Circuits for Control of the Seoul Olympic Games

図1. ソウル・オリンピックゲーム支援の回線数

TV (included CCTV) 96 (International 8) (1%)

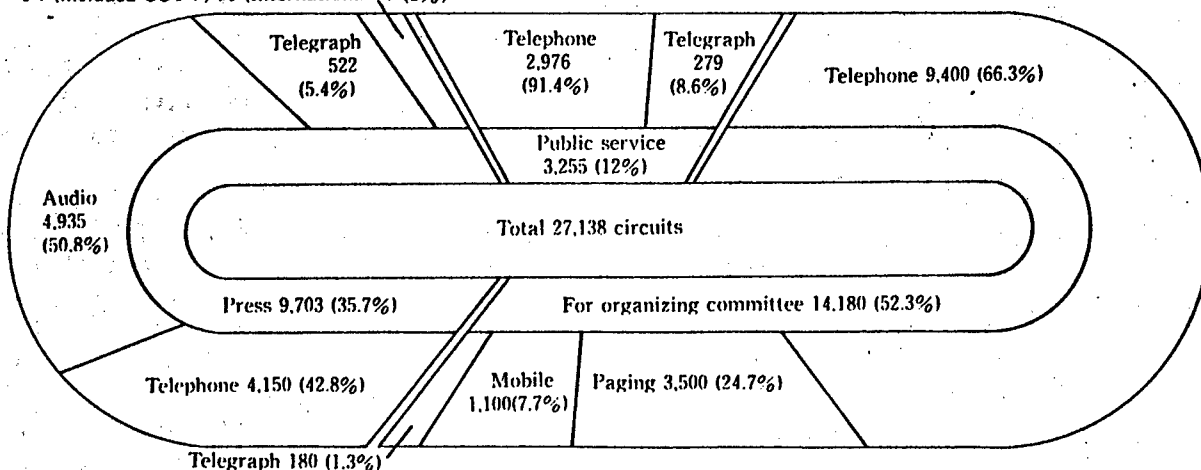

THAILAND

BRIEFS

MOBILE PHONE SYSTEM FROM ERICSSON----Thailand has ordered a mobile telephone system from Ericsson Radio. The order is worth 100 million kronor. The order includes an MTX mobile phone exchange in Bangkok and the coastal area around Rayong. The system in the long run will be expanded to cover most areas of Thailand. The first stage is planned to be in operation during 1986. [Text] [Stockholm SVENSKA DAGBLADET in Swedish 2 Jul 85 p 21]

CSO: 5500/2685

CANADA

## CANADIAN FIRM PROVIDING CABLE TV SERVICE IN AMAZON

Toronto THE GLOBE AND MAIL in English 7 Jun 85 p B21

[Text] The first thing Stanley Tyminski noticed three years ago when he flew into Iquitos, Peru, in the middle of the jungle, was that the houses were built on stilts to protect them from the changing level of the Amazon River.

And the second thing was that thousands of them had television antennas.

The communications engineer was on vacation, relaxing from the pressures of building Transduction Ltd. from a small computer company into a thriving cross-Canada business with annual sales of almost \$7-million. His partner, Ron Shawley, was at home in Mississauga, Ont., minding the store.

Today, the partnership is in business in Iquitos, a city of 100,000 about 600 kilometres west of the Peruvian capital of Lima, where Mr. Tyminski is running TVS Iquitos, a

profitable cable TV service.

"People were starving for entertainment, yet there was only one local television channel, offering limited programming only until 10 p.m.," he said.

The Government refused Mr. Tyminski a licence to open a second channel. But no licence is needed to operate a cable station in Peru.

With funds supplied by his partner, he hired a local cameraman and a reporter and began producing his own shows. Then he built a 300-kilometre cable through the thick jungle terrain to supply the service to isolated jungle villages.

It wasn't easy.

"Animals were chewing on the cable and disrupted the signal," he recalled. "So we laid heavier cable and elevated the lines off the ground."

TVS Iquitos also had to cope with a scarcity of skilled manpower and supplies, government upheavals, terrorism and a rainy season that made work

virtually impossible for a substantial part of the year.

Early in 1984, the company installed the first satellite dish in the region. Within weeks, dozens of Amazon communities had heard of the exciting television programs available in Iquitos and were asking for satellite dishes of their own. By the end of the year, two more were in operation.

Today the company has 3,600 subscribers who pay \$15 a month for the service.

"Our subscribers can receive clearly up to 20 channels, not only from Lima but from neighboring countries like Brazil, Colombia and Ecuador," Mr. Shawley said. "For \$10,000 we can install a complete receiver-only TV system anywhere in the Amazon region."

Two months ago, TVS sold a system to an army base about 250 kilometres downriver from Iquitos.

"We now have a product that works well under very diffi-

cult conditions," Mr. Tyminski said. "We're about three years ahead of anyone who tries to compete with us in Latin America."

Mr. Shawley, whose laid-back style makes him the perfect foil for his intense, innovative partner, estimates that there is a market worth \$4-million a year in Peru alone and said the company plans to expand into neighboring Brazil and Colombia, creating a score of jobs at the Transduction Ltd. plant in Mississauga which supplies equipment for the South American venture.

"In the next two years we will probably triple our work force in Canada, from 30 to 90 employees."

But in Peru the partners have avoided the common practice of foreign companies of parachuting in outside experts and hiring locals only as laborers.

"We have hired and trained 60 Peruvians," Mr. Shawley said. "Stanley is the only Canadian there."

Canadian Press

GERMAN DEMOCRATIC REPUBLIC

GDR OPPOSES PLANNED COMMERCIAL RADIO EXPANSION

DW111033 Hamburg DER SPIEGEL in German 10 Jun 85 p 14

[Unattributed article: "GDR Puts Brakes on Commercial Radio"]

[Text] In an as yet unpublished letter to the Federal Government, the GDR last month came out against Bonn's plans for commercial radio. This will delay the setting up of the new radio stations using ultrahigh frequencies that Minister of Post and Telecommunications Christian Schwarz-Schilling (CDU) wants to push forward.

The Ministry of Post and Telecommunications in East Berlin refers in its rejection to an international law that prohibits the use of radio frequencies designated for national use by radio stations in neighboring countries. The GDR has the right to use until 1 July 1987 those ultrahigh frequencies (100 -- 104 MHz) that Bonn planned to use in its accelerated launching of commercial radio. The international radio conference in Geneva decided that Bonn may use the frequencies in question only after 1 July 1987. Although it no longer uses these frequencies, East Berlin rejected Schwarz-Schilling's proposal that the date be brought forward. This means delays above all for the program plans of the laender governed by the Christian Democrats. Lower Saxony and Schleswig-Holstein had intended to launch commercial radio programs broadcast from Hannover and Kiel, respectively, to corner the advertising market in Hamburg. The establishment of radio programs will be delayed in Rhineland Palatinate and Baden-Wuerttemberg for up to 20 months.

Only in Munich was the land government able to bring about a fait accompli, which remained unaffected by the GDR's veto. In the state capital, Bayerischer Rundfunk handed over to 11 new radio stations -- from Axel Springer to Radio "Xanadu" -- 3 frequencies of its own previously held in reserve.

Media experts in Bonn assume that the GDR intends to exploit the CDU/CSU/s haste in moving forward in radio policy to get a concession for giving up the frequencies ahead of schedule, a concession such as shielding the GDR from FRG ultrahigh frequency radio stations or directing Deutschlandfunk away from the east. This would lead to conflicting goals for the Christian Democrats: If they keep to the schedule for introducing commercial radio, they would have to accept a restriction on the amount of information freely passing to the GDR.

CSO: 5500/2681

1 August 1985

## HUNGARY

## CONSTRUCTION OF CROSS-BAR TELEPHONE EXCHANGE DESCRIBED

Budapest VASARNAPI HIREK in Hungarian 2 Jun 85 p 4

[Article by M.G.L.: "Where Will the Telephone Numbers Change in Buda? New Subscribers, Telephone Booths, Supplement to the Directory. Information Service Starting Monday"]

[Text] The largest postal investment of the sixth 5-year plan in the capital, the construction of the new Krisztina cross-bar telephone exchange and the associated network improvement and expansion, is nearing conclusion. After completion of the 2-billion forint project, starting in November of this year, the telephone situation in Budapest will improve markedly.

The favorable changes were summarized at a press conference last weekend by the spokesman of the Hungarian Postal Service as follows: In the exchange area of the old and new Krisztina center-- in the first, second and 12th districts of the capital, several antiquated telephone exchanges will be decommissioned, old cables will be exchanged, the lines will be expanded by more than 96,000 kilometers and the number of subscribers wired for long-distance calls and time-metered service will increase by 4,000. Telephone booths from which local and long-distance calls can be made will increase by a hundred.

This year and next the Postal Service will install 13,340 new stations in the concerned districts of Buda.

The startup of the "new Krisztina" will impact other parts of the city as well. The 8,200 stations that were formerly "on loan" from other exchanges will be returned so that in two or three years, in proportion of the development of the network, new subscribers can be connected primarily at Lagymanyos, Terezvaros and Obuda.

The linkup of the new subscribers to either the old or the new Krisztina exchange cannot happen from one day to the next. The experts of the post office have proposed a well-considered plan about this, according to which already this year 6,250 new stations will begin operation. At the same time, because of technical considerations, 22,000 stations must change their call numbers at Kozep-Buda.

The Postal Service cannot help this! For this reason, at the end of October, the post office will publish a supplement to the telephone directory. By the way, a service, reachable at 179 666, will furnish information until the end of the year about the changed numbers. Starting Monday, customers will be received in Budapest in a building in the 12th district at Maros St 32, every day. The attached map and the material in the text give information about the changes in the affected parts of Buda and, in a simplified way, about the call numbers.

The limits of the "A" sector are: Zsigmond Sq, Szerena Rd, Csejtei St, Pusztaszeri Rd, Also-Zoldmali Rd, Felso-Zoldmali Rd, Torokvesz Rd, Gabor Aron St, Hankoczy Jenó St, Filler St, Lorantffy Zsuzsanna St, Szilagyi Erzsebet Rd, Moszkva Sq, the northern and eastern wall of the palace-district (Sziklai Sandor Rd, Hunfalvy St), Dobrenței Sq and the right bank of the Danube.

The phone numbers starting with the digits 15, 16, 35 and 36 will not be changed here.

There will be changes in the call numbers of some high volume non-private stations and in the numbers of stations borrowed from other exchanges. In this area 34 percent of the persons on the official waiting list will receive a telephone in the first half of December, the others can get one only at the end of the seventh 5-year plan or at the beginning of the eighth.

The "B" sector is the district bounded by the following: Dobrenței Sq, the eastern and northern walls of the palace-district, Moszkva Sq, Szilagyi Erzsebet Rd, Lorantffy Zsuzsanna St, Filler St, Hankoczy Jenó St, Gabor Aron St, Szilagyi Erzsebet Rd, Kutvolgyi Rd, Feszek St, Galgoczy St, Susogo St, track of the funicular railway, Zsiboi St, Istenhegyi Rd, Nagyenyed St, Krisztina beltway, Dobrenței Sq.

In this area all call numbers will be changed in the second half of November.

In the "B" sector there will be a large number of new stations opened during the next year. The spokesmen for the Postal Service indicated that 72 percent of those waiting will get a telephone.

The limits of the "C" sector are as follows: Dobrenței Sq, Krisztina beltway, Nagyenyed St, Istenhegyi Rd, Orban Sq, Fodor St, Tallya St, Burok St, Farkasreti Cemetery, Jagello Rd, Csorsz St, Alkotas St, Hegyalja Rd and the right bank of the Danube.

In this area, all call numbers will be changed in the second half of November. New stations can be expected from the second half of next year. A piece of favorable news for the people living here: three-fourths of the officially recorded installation requests can be honored by the Postal Service.

The "D" sector falls between the following limits: Bela Kiraly Rd, Kutvolgyi Rd, Galgoczy St, Susogo St, Zsiboi St, Istenhegyi Rd, Orban Sq, Fodor St, Burok St, Janos Zsigmond St, Adorjan St, Irhas trench, Nagykapocs St and the western limit of Budapest.

Here non-private call numbers will be changed in the second half of November and the private numbers during the next year.

In this area no new stations can be expected to be established before 1988.

According to present plans, substantial improvement will come with the further expansion of the telephone exchanges at the end of the seventh and the beginning of the eighth 5-year plan.

12846

CSO: 5500/3025

INTER-AMERICAN AFFAIRS

SPACE CONFERENCE ISSUES SATELLITE PLACEMENT RECOMMENDATIONS

Bogota EL TIEMPO in Spanish 1 Jun 85 p 7-C

[Text] Representatives of Colombia, Ecuador, Peru and Bolivia yesterday approved 10 recommendations aimed at achieving a joint position on the use of the geostationary orbit and backed Colombia's charge regarding the placement of U.S. satellites over that country.

The decision was adopted at the third preparatory meeting for the World Administrative Conference on Space Radiocommunication Services Planning, which was held in Bogota for 3 days.

The recommendations insist on the need for a priori planning in view of the growing degree of congestion caused by the highly technologically developed countries, as well as support for Colombia's position in its charge regarding the lack of compliance with international radiocommunications regulations in the cases of the satellites Galaxy-2 and Usassat-8B.

The importance of this charge was emphasized inasmuch as the Andean countries proceeded on the disputed orbital position--72 degrees West--the anticipated placement for one of the satellites of the projected Andean regional system, the "Condor."

At the same time, they will favor planning of fixed service by satellite in the 6/4 gigahertz and 11/14-12 gigahertz bands of frequencies and will decide the advisability of convening a conference for planning on the geostationary orbit and the radioelectric spectrum that may not merit an immediate plan because of its less intense utilization.

Similarly, the approval of a number of planning principles and elements was recommended based on Resolution Number 3 of 1979 to guarantee equal access to the geostationary orbit and the radioelectric spectrum, in technical, economic and juridical terms.

At the same time, they emphasized the need to adopt all timely technical measures in order to restrict to the maximum the spillover of radiocommunications signals over countries other than the responsible one by its satellite telecommunications networks.

The Andean Group also recommended the banning of international coverage that affects countries or groups of countries without their prior authorization.

Another suggestion is based on the adoption of a schedule to incorporate technical parameters that will permit effective utilization of the geostationary resource according to the criterion of minimum economic impact on the developing countries.

Finally, the spokesmen of the Andean countries requested preferential access by the equatorial and Andean countries to orbital positions situated in geostationary arcs located over their territories in view of their geographic and orographic situation as countries cut from north to south by mountain ranges.

8711

CSO: 5500/2085

BAHAMAS

## NATION BECOMES 10TH MEMBER OF INTELSAT AGREEMENT

Nassau THE TRIBUNE in English 17 Jun 85 p 7

[Text]

WITH the signing of the International Telecommunications Satellite Organization's (INTELSAT) Operating Agreement on May 30 the Bahamas became the 110th member of INTELSAT.

The signing ceremony took place at the Department of State in Washington, DC. Signing on behalf of the Bahamas were Mr Edison Key, Chairman of BaTelCo and Robert Bartlett, General Manager. Also present from the Bahamas Embassy in Washington were Miss Maria Teresa Butler, First Secretary and Mr Winston Munnings, Second Secretary.

Although The Instrument of Accession to the INTELSAT Agreement was signed in Nassau on April 11 by Minister of External Affairs Clement Maynard and lodged with the secretary of State, the Agreement did not come into force until the Operating Agreement was signed by BaTelCo, the designated telecommunications entity. The Operating Agreement had to be signed at the Department of State in Washington.

As a member, the Bahamas through BaTelCo, has become a shareholder in INTELSAT.

INTELSAT is a co-operative made up of 110 countries, which owns and operates the global communications satellite

system used by countries all over the world for both international and domestic communications. Two-thirds of the world's international telephone service and virtually all international television transmissions are carried over INTELSAT satellites.

BaTelCo is now in the process of evaluating tenders for a Standard 'A' INTELSAT earth station, which will be ready for service by the end of 1986. This facility will comprise a 30-metre diameter parabolic antenna which will enable BaTelCo to establish direct telecommunication circuits with many foreign countries around the world. It will provide the capability and diversity required to enhance BaTelCo's international network in addition to offering the security of a restoration facility in the event of failure of the existing submarine cable between the Bahamas and Florida.

After the signing ceremony, INTELSAT hosted a luncheon in honour of Messrs Key and Bartlett at the new INTELSAT Headquarters Building on Van Ness and Connecticut Avenues, N.W. The building is unique in design, energy efficient and is expected to have an annual energy bill equal to only 40 per cent of the average cost for other Washington buildings of comparable size.

CSO: 5540/043

CUBA

BRIEFS

TELEVISION MODERNIZATION PLANS--Ninety percent of the nation's territory receives television signals. The Ministry of Communications plans to buy from CSSR in the next 5 years 12 large transmitters which will substitute the present ones which are 30 years old. One hundred and thirty relay stations built domestically will be installed for remote areas which have problems receiving signals. High gain antennas will be installed in the mountains. A third television channel is planned for Havana. Extension to other provinces is possible, depending upon funds available. [Text] [Havana Domestic Service in Spanish 1700 GMT 8 Jul 85]

CSO: 5500/2089

1 August 1985

JAMAICA

## BRIEFS

DATA SATELLITE--Prime Minister Edward Seaga said Thursday that negotiations on the establishment of an enormous high speed data transmitting satellite capable of transmitting satellite capable of transmitting 30 typed pages per second which were being pursued by the JNIP, was at a very advanced staged. In his Budget speech Mr. Seaga said that the introduction of the satellite would open vast opportunities for new data processing enterprises and the establishment of off-shore offices, which were high employment operations, in Jamaica. [Text] [Kingston THE DAILY GLEANER in English 8 Jun 85 p 3]

CSO: 5540/042

AFGHANISTAN

FAIZABAD TV STATION IN OPERATION

Kabul KABUL NEW TIMES in English 15 Jun 85 p 2

[Text] Faizabad (BIA)--The installation of a TV station in the centre of Badakhshan Province has been completed here and it operates on the 12th SECAM channel.

A spokesman of the concerned source saying the above added that the station was installed in accordance with the joint plan of the State Committee and ministry of communication of Radio-TV and Cinematography of the DRA.

The new TV station equipped with modern technology is to have two hours' programmes daily. It is consisting of two parts, i.e. to rally news reportages, informational and educational programmes, etc being transmitted by the 'Shamshad' satellite communication system from the central TV station and the second part of its programmes are prepared from the archives of the province itself.

CSO: 5500/4740

ALGERIA

BRIEFS

RADIO, TV ACCORD WITH IRAQ--At the Iraqi radio headquarters in Baghdad, a protocol of cooperation between the Algerian and Iraqi Radio and Television in the field of cultural and artistic programs exchange, was signed in Baghdad today. The protocol was signed on behalf of the Algerian side by brother Algerian Ambassador to Iraq Al-Haji Hamdadoui and (Majid Ahmad), the director general of radio and television on behalf of the Iraqi side. On the occasion, there was an exchange of speeches by the two sides. They lauded the agreement which tends to strengthen cooperation between the two fraternal countries especially in cultural and artistic fields. [Text] [Algiers Domestic Service in Arabic 1900 GMT 4 Jul 85 LD]

CSO: 5500/4607

BANGLADESH

PAPERS REPORT TELECOM SITUATION, FUTURE PLANS

Third Five-Year Plan Aims

Dhaka THE BANGLADESH TIMES in English 11 Jun 85 pp 1, 8

[Text] Bangladesh Telephone and Telegraph (T&T) is planning to change its present billing system of counting the holding time of telephone conversation to charge on "bit by bit" process of counting the words spoken by the caller.

This would be possible because of digitalisation of switching, transmission and local networks, said Engineer M.A. Salam, Director, Planning T&T Board, while delivering a talk on "telecommunication system in Bangladesh--past, present and future"--at the Institution of Engineers on Monday.

Describing the past of T&T which started with 1,500 manual telephones all over Bangladesh in 1947 including 900 line CB exchange in Dhaka, Mr Salam said that it would introduce mobile telephones within the city and for long distance radio telephones would be used in large numbers for the rural areas and infra-ray cordless telephone in the city areas, Mr Salam said.

The country's potential demands for telephones were rising with about five lakh sets. But due to financial constraint T&T would provide 1,80,000 new telephones during the Third Five-Year Plan period. Out of this, Greater Dhaka would have 90,000 sets.

The lecture session was presided over by Dr S.I. Khan, Chairman, Seminar and Conference Committee of the Institution of Engineers. Dr Mahfuzur Rahman Khan, Chairman, Department of Electronics and Computers, University of Engineering and Technology, was the main speaker. Earlier, Engineer Ruhul Matin, General Secretary, Institution of Engineers, introduced Mr Salam to the audience.

Giving a description of current use of telephones in Bangladesh, Mr Salam said that at present there are 1,57,000 automatic and 25,000 manual telephone capacity in T&T's installed network making the total installed capacity to 1,82,000 providing a density of 1.8 telephone per 1,000 population.

However, Mr Salam said the rural penetration of telephone was very low. In the upazilas 144 magneto manual exchanges were installed. But almost all the district towns have automatic exchanges. In all T&T had 79 automatic exchanges in its network, he added.

#### Other Facilities

On other facilities of T&T Mr Salam said that there are about 600 telegraph offices in the country with important district towns interconnected by point to point teleprinter circuits. In other places Morse codes or Phonogram service was available. Telex installed capacity was 1,418 lines including a 1,000 line digital telex exchange in Dhaka. Chittagong and Khulna are connected with Dhaka telex by line concentrators.

One standard-A earth station at Betbunia and a standard-B earth station at Talibabad are providing 130 overseas telephone circuits and 96 telegraph--telex circuits with 18 overseas countries.

#### Modernisation

For nationwide dialling (NWD) four-digital electronic trunk exchanges have been installed at Dhaka, Chittagong, Khulna and Bogra. So far 25 districts have been connected with these NWD exchanges for intercommunication. A digital International Trunk Exchange (ITX) had also been installed at Dhaka for overseas direct dialling and operator assisted trunk services.

#### Revenue Jump

About the revenue of T&T he said that it was rising with the introduction of modernised systems. The annual revenue receipt increased to Taka 142 crore during the last financial year compared to Taka 60 crore in the previous year. This jump in revenue was possible due to introduction of NWD and ITX services, Mr Salam added.

On the expansion of telecommunication facilities in the rural Bangladesh, Mr Salam said that digital switching system would be installed in all the district headquarters. Remote line units would be installed in the upazila headquarters for direct communication with district headquarters. The upazilas would be provided with a 100 line digital concentrator each.

The facility of digital concentrator could provide telephone connection, pay phones, coin box etc to union parishads from upazila headquarters directly, making it possible to extend good telephone facilities in all the 5,000 union councils.

1 August 1985

## More Details Given

Dhaka THE NEW NATION in English 11 Jun 85 pp 1, 8

[Text]

The telephonic overcrowding in the city may linger for another five to seven years, or get even worse. But the jam in the inter-district traffic may be free by the end of 1986.

This was revealed in a discussion yesterday at the auditorium of the Institution of Engineers on "Telecommunication in Bangladesh Past Present and Future". The key-note paper was presented by Mr M A Salam, director, planning long distance & long term, T&T Board. Dr S. I. Khan presided over the seminar.

Referring to the expansion scheme of the T&T Board Mr Salam said, during the Third Five Year Plan with a plan size of Tk. 698 crore with foreign exchange component of 255 crores 91,000 new telephone connections would be given. This would be in addition to the 90,000 connections in Dhaka. The city's expansion scheme is a part of the carry-over of the original Second Five-Year Plan.

With the completion of the project the existing telephone lines would register a 100 per cent rise over a period of five years. The growth rate for the previous corresponding period of five years was 50 per cent. Referring to the T&T development scheme that features these projections, he said during the period the country's telecommunication technology would record a big leap towards digital switching technology. This would interlink the upazilas with the nearest district headquarters as a part of the city subscribers thus enabling them to enjoy the facilities of nationwide dialling.

Replying to a question he said, the digital technology would require major renovation of the existing system thus making the present system almost wholly obsolete. He said, the technology is being adopted only because

donors are sponsoring it. Whether the telephone industry of the country would be able to produce adequate number of sets and exchanges required to make a switch-over to digital viable, he said, a manufacturing plant is only feasible with an annual capacity of three million sets but the country's demand is around 40,000 per annum. He said steps are afoot to produce necessary number of exchanges in the country by assembling though the number is not adequate for having even an assembling plant.

Giving an outline of the Third Five-Year Plan he said the second phase of the nation-wide dialling has been given the first priority. In the second phase four trunk automatic sub-exchange (TAX-SE) would be set up to expand the nationwide dialling as well as simplifying the mechanism and making it more cost effective.

Another feature of the T&T's Third Plan exertions would be the Gentex, an improved method of telex with an electronic memory device. Answering a question he said, instead of importing a microwave link, an earth station of the communication satellites would be set up as Betunia would be out of order within five years. This earth station would solve the jam in nationwide dialling but due to the delay in importing and installation of the sophisticated exchanges, junctions and radio equipment the telephonic system within the city would remain troublesome, especially during the peak-load hours, for another five to seven years.

Mr Salam revealed that there was a potential demand of over five lakh connections all over the country while by the end of the Third Plan in 1990 the number of connections would be around 3,65,000.

Editorial Examines Prospects

Dhaka THE NEW NATION in English 13 Jun 85 p 5

[Text]

It is good to know that the telephonic jam in inter-district traffic may be cleared by the end of 1986, a move that will be a great improvement over the constraints that our telephone system currently suffers from. A discussion held in Dhaka the other day also revealed that the telephonic overcrowding that is to be noticed in the capital city could persist for another five to seven years and even holds the possibility of getting worse. That, as one is tempted to say, is certainly not encouraging news.

The discussion, styled "Telecommunication in Bangladesh, Past, Present and Future," was a good endeavour in that it was able to inform the general public of the problems and prospects regarding our telephone services. It was revealed that during the Third Five-Year Plan, the expansion of the T and T Board envisages a total spending of Tk. 698 crore, of which the foreign exchange component is to the tune of Tk. 255 crores. Under the expansion plan, 91,000 new telephone connections are to be provided in Dhaka in addition to the 90,000 connections that already exist. An important aspect of the expansion scheme is that over a period of five years from now, the existing telephone lines will register a hundred per cent rise as against the fifty per cent growth of the previous five years.

As the discussion has revealed, an important move that is being envisaged now is a switch-over to the digital system. Such a step is being considered in view of the need to interlink the upazilas with the nearest district headquarters. However, the fact remains that the country-wide adoption of the digital system would entail a major renovation of the existing system and, as we have been told, the task is being undertaken only because donors are sponsoring it. What remains to be seen is to what extent the country's telephone industry is able to produce the required number of sets and exchanges if the digital system is to be

brought in. A digital system oriented manufacturing plant, we are told, is feasible with an annual capacity of three million sets; and our annual demand is a mere 40,000. Surely, the matter deserves to be given more thought.

The telecommunication seminar, let us say, has been useful in the sense that

it has enabled us to take stock of our telephonic position; and, obviously, good suggestions have emanated from it. For us now, it is a question of how far we can proceed in our overall scheme of telecommunication development with the resources that we possess. We would expect our telecommunication authorities to address themselves to the task of development they have set for themselves. Country-wide, the potential demand for telephone connections is about 5,00,000 but by the end of the TFYP in 1990, the number of connections is expected to be 3,65,000. It would be worthwhile to do something in this particular area as a first step.

CSO: 5550/0117

EGYPT

BRIEFS

PLAN TO LAUNCH SATELLITE--AL-RA'Y AL-'AMM has learned that a high-level committee has been formed under Dr 'Abd al-Qadir Hatim, general supervisor of the national council for the preparation of final concepts on the feasibility study of a project to launch an Egyptian satellite for information and telecommunications with the rest of the world. The committee has estimated the cost of manufacturing, equipping, and launching the satellite to be \$200 million. The decision by Egypt to launch a satellite comes in response to the launching of the Arab satellite and the denial of permission for Egypt to use its services. [Text] [Kuwait AL-RA'Y AL-'AMM in Arabic 14 May 85 p 1]

CSO: 5500/4606

INDIA

BROADCASTING MINISTER ON LIBERALIZATION POLICY

Calcutta THE TELEGRAPH in English 16 Jun 85 p 6

[Interview with V.N. Gadgil by Tavleen Singh]

[Text]

**Q:** *You have recently been quite critical of the press, I think in connection with the coverage of the bomb blasts in Delhi. Could you explain what exactly you felt was wrong?*

**A:** I didn't criticise. I said, I speak with anguish—that was the word I used. It was really two newspapers (that the criticism was directed against). One published a story saying that a terrorist had been arrested by the police because a neighbour overheard a telephone conversation and that there was a cordless telephone and that is why the conversation could be overheard. In the present situation to publish this sort of thing, when a man is doing his civic duty, is it right? Now he will be on the hit list. The second newspaper published the bomb formula. Is this the sort of thing that the press should do?

So what I said was that some self-introspection was required. The government does not want to evolve a code (for the press) but maybe the press needs to evolve one itself. For instance, the recent *Illustrated Weekly of India* cover said 'Target Rajiv Gandhi'—I don't think it's the kind of thing that should be done by the press.

**Q:** *What do you feel about the Punjab coverage in general?*

**A:** Well, I said in the speech I made in Cochin that by and large the press has behaved very responsibly. I have no complaints, except these two instances which I mentioned. And they are all the more disturbing because they appeared in the national media, I can expect some cheap, district newspaper doing it, although even it shouldn't do so.

**Q:** *What exactly do you mean by a media policy?*

**A:** The origin (of the idea) goes back to when I was minister for communications for two years. The year 1983 was observed as World Communication Year and a lot of seminars were held. When I go into a new ministry I do a lot of reading on the subject and so, I found myself reading a lot about the concept of an information society in the west. It struck me since we have an education policy we could as well have a national communication policy. I got a rough draft prepared with the idea that it should be circulated among all the ministries and then be presented as a paper to the nation, debated in Parliament and then approved.

My idea was to involve newspapers, AIR and TV, education, the technical side of com-

munication, the printing press industry, the government and even the citizens, and the object would be to find out the role of each one of these components in the national communications policy for the establishment of an information society. It is nothing to do with censorship or how the press should behave.

**Q:** *But who is to decide?*

**A:** Let there be a discussion. For example, there are various points of view about the role of the press, let it be debated, what role should the press play in evolving an information society.

**Q:** *What exactly do you mean by an information society?*

**A:** In the west, there has long been a debate (over such a society). Today the ordinary citizen claims he has the right to know certain facts because communication has become much faster and no economic development, leave aside political, can take place without correct information.

**Q:** *So, basically, you are just talking about the availability of information, not the control of it?*

**A:** No, I am not talking about controls.

**Q:** *Well, recently printing presses have been removed from the OGL (open general*

licence) list and put under restricted imports, and people are thinking that this is perhaps an attempt to exercise some form of control.

A: Frankly, I do not know why this has been done but I have already taken up the matter with the finance ministry. Some people had come to me from the printing press industry and there is some substance in what they say. They say that offset and photo-composing are technologies that have already been acquired by big newspapers, but the present policy will prevent medium newspapers from acquiring them.

Q: To come to television, there is an impression going around that there has been a great deal of liberalisation in the past few months. 'Janavani' is a case in point. Has this been a conscious policy decision?

A: I would put it this way, we are trying now to increase the credibility of AIR and Door-darshan and for that we have taken a number of steps. I don't want to bore you with statistics, but if you take the period of the elections, October to December, the Opposition was given double the time the ruling party got. Secondly, when Assembly elections were being analysed, there were two or three independent journalists who made very critical comments about the ruling party.

For example, they said that in the south, the Congress had lost because removing N.T. Rama Rao was a wrong step. They spoke frankly about Sikkim, too. We also had a very sensitive discussion on Punjab when two of the participants were very outspoken and even the moderator took sides. We said, let it go, we will present the other side tomorrow.

There is *Point-counterpoint* every month and *Panorama* (both of which are objective programmes). Again, from January to March, we brought 25 Opposition MPs on TV on issues before Parliament, budget reactions, whatever, whereas only nine Congress(I) MPs came on. Then we have brought a number of independent academicians, journalists, etc., on TV, who are not

pro-establishment by any stretch of the imagination. Take *Janavani*. It was entirely the Prime Minister's idea. He told me I want my ministers to come face to face with the common man—so we evolved the programmes.

What I have allowed is complete editorial freedom, subject to the guidelines that were evolved by the ministry 20 years back.

Q: So, is this a conscious policy coming from the Prime Minister?

A: It is his general directive. He said we should have all points of view on AIR and TV. The rest was left to me.

Q: What are your views on autonomy?

A: I am against it.

Q: Why?

A: Autonomy is no solution, because if I want to interfere I can interfere in an autonomous corporation, but if somebody doesn't want to interfere, even if it is a government department, objectivity and impartiality can be there.

Q: Do you therefore feel that something like the BBC wouldn't work here?

A: Well, my views are not liked by most people but I don't believe that the BBC is that objective. I can quote several instances including from autobiographies and biographies of their ministers. First, James Margau, *London Times* Special Correspondent covering Westminster for nearly 50 years, wrote a book called *Abuse of Power* in which he says except for Attlee and Hume all the Prime Ministers interfered with the media. Second, Lord Hill, who was the chairman of the BBC and wrote a book called *Behind the Screen*, has quoted instances of the Labour Party saying that the BBC was dominated by the Conservative Party and the Conservatives saying the opposite. Towards the end of the book he says that there is a distinct bias in the news given by BBC. Then there is a book called *Culture Gap*, written by a British minister in which he says that BBC is a cage and they take care to see that you are not made aware of the cage.

Or, take the *London Economist*, which I have quoted in Parliament. It says that one Labour MP has said recently that not only does the BBC not project the views of the working class but it tries to mould the views of the working class and that the BBC itself has become part of the establishment like the Church of England or the Bank of England. So it is not as if the BBC is very impartial or objective; it never has been. That autonomy is no solution is the point I am trying to make.

Q: Then, what is the solution? At the moment we are lucky enough to have a Prime Minister who believes in liberalisation, what happens if tomorrow we have one who doesn't...

A: Ultimately, it is always the men (who run the government) who decide. In some totalitarian countries they have the most democratic constitutions in the world. Some of them even grant the right to secede after a referendum. But it doesn't make any difference. Ultimately, it depends only on the men who work the system.

Q: So you feel that no institutionalisation of autonomy is required?

A: It doesn't help beyond a point. It will not make any distinct difference. With the kind of liberalisation you mentioned, you know what will happen: you will have a corporate body, offices, chairman, management, the whole paraphernalia, which is unnecessary in a developing country. And that is why I think Pandit Jawaharlal Nehru was right when he said in the Constituent Assembly in 1948 of the provisional Parliament though the government would like to have something like a semi-autonomous corporation, the time was not ripe for it. India is a developing country where these foreign ideas cannot be implemented straightway.

Q: Do you feel that in Door-darshan there is room for much more professionalism?

A: Yes, we have introduced a lot of it in the form of sponsored programmes. By and large I'm satisfied with

the entertainment aspect of TV but the other aspects, educational and information, in my view need a lot of improvement.

*Q: The impression one gets from watching the sponsored programmes, is that the producers are not aware that India is a multi-lingual and multi-cultural country. The programmes are all in Hindi and they purvey the north Indian culture.*

*A: Yes, there is substance in what you say. We have taken two decisions recently. One is that like Hum Log there should be a serial based on a rural family because more and more of our viewers are going to be rural. Today, though they watch Hum Log they cannot identify with it. Secondly, we have decided to give more time for sponsored programmes to people from Madras or Calcutta.*

*Q: But what are you going to do about language, because it will still all be in Hindi?*

*A: There the problem is technical. Today we have three systems operating, one is Delhi, connected with some adjoining stations; then there are the metropolitan cities; and lastly, there is the national network—174 stations. Since*

*we have only one channel, only one programme can go to these 174 stations. To remedy this only two things are available. The first is a transponder (the mechanism to give the audio channel) INSAT-1B, has only one transponder. In INSAT-1C we have asked for three, one as a standby, two to be used. This means that from 5.30 pm-8.30 pm, instead of seeing Delhi programmes you can have, for instance, Kannada programmes, produced in Bangalore, telecast all over Karnataka. It will give us the choice of more channels and the possibility of local language programmes, at least between 5.30 and 8.30 every evening.*

*The second remedy is a microwave link. If such a link is established by the P&T department, then again we can have the same facility and this we have proposed in the Seventh Plan.*

*Q: The other thing that is worrying us is the message of consumerism that some of these new TV soap operas and situation comedies seem to convey. Is this the right kind of fare for rural audiences—imported telephones, imported TV sets and so on?*

*A: We have tried to convey messages of social relevance with entertainment...*

*Q: Where are these messages?*

*A: For instance, prohibition, and dowry. I am told that after the Hum Log serial was started, dowry deaths have come down in Delhi. It may be a coincidence but this is the position. We are trying to pass the message in a subtle way. I agree that, at the moment, the entertainment part is dominant.*

*Q: What is the message in Idhar Udhar, Yeh Jo Hai Zindagi, Khaandaan?*

*A: Khaandaan has a message, it shows what goes on in society, what should not be there... The setting of most of the serials is a Bombay flat. I have suggested that it be changed—to a chawl, for instance.*

*Q: These sponsored programmes are there to advertise certain products. But has any attempt been made to ensure that certain commercials that can be harmful, particularly to rural audiences are not allowed? I may mention baby-food commercials in this context.*

*A: No, this has not come to my notice.*

CSO: 5550/0113

INDIA

## INDIAN TV TO EXPERIMENT WITH TELETEXT SERVICE

Madras THE HINDU in English 12 Jun 85 p 6

[Text]

NEW DELHI, June 11.

A teletext service based on the French system called "Antiope" will be introduced shortly by Doordarshan on an experimental basis in Delhi. It will enable television viewers in the capital get the latest information on a variety of topics like weather forecast, flight and train timings, foreign exchange rates and share price movement whenever they want during transmission period.

The Government has opted for the French system on the basis of the recommendation of a team of officials, who visited Britain, France and Japan a few months ago and examined the different systems in vogue. The French system has been favoured as it can be adapted easily for transmitting messages in Indian languages as well.

**Within six months:** A team of officials drawn from Doordarshan, the Electronics Corporation of India (ECIL) and the National Informatic Centre (NIC) is now in France for familiarisation and inspection of the equipment offered by that country. The equipment is expected to be received by July-end or early August. After initial testing, the service is expected to be offered on a regular basis within six months.

To utilise this service, the television receiver sets have to be fitted with decoder facility. Initially, a certain number of decoders are being secured from France and these will be fitted to the TV sets belonging to Doordarshan and of some select VIPs. Meanwhile, indigenous production of decoders will be taken up. Each decoder is estimated to cost Rs. 2,000 now, but as demand grows and production increases, the price may come down.

**Continuous feeding:** The scheme envisages continuous feeding of information from various sources to the imported equipment set up at

the studio and transmission through the TV network. Even when a regular programme is on, the viewer, by switching on the decoder, can get the latest news on the TV screen.

To ensure regular flow of news and other information, Doordarshan is making arrangements with sources like International Airport Authority for flight timings, the Meteorological Department for weather forecast and the news agency, Press Trust of India, for spot news on general subjects and on foreign exchange rates, etc.

The ECIL has been chosen as the prime contractor for importing the equipment from France and erecting it in Doordarshan studio.

The Sofratev Broadcasting Development Company, the consultancy wing of the official Telecom Department of the French Government—with whom the Indian team had negotiated for the "Antiope"—offered both broadcast version and interactive version but the Government of India, for the present, has gone in for the former.

In the broadcast version, a viewer whose TV is equipped with a decoder and is tuned to a channel containing video text information may select on his keypad any page among the thousands available on call. The page of text and diagram is displayed on the TV screen for as long as the viewer wishes.

In the interactive version, a viewer whose TV set is equipped with a decoder can use his telephone to request any page among the thousands stored in a database. The page of text and diagram is displayed on the TV screen for as long as the viewer wants.

The use of the teletext service is expected to ease the load on telephone service due to calls making enquiries about plane and train timings, currency and commodity quotations, etc.

INDIA

MINISTRY SEEKS TO EQUIP RELAY CENTERS FOR STATE CAPITALS

Calcutta THE TELEGRAPH in English 18 Jun 85 p 5

[Text]

Darjeeling, June 17: The Union information and broadcasting ministry has initiated a dialogue with the ministry of space for equipping and allotting three transponders in the next Insat satellite to be launched in June next year.

Mr V.N. Gadgil, minister of state for information and broadcasting, said on Friday at the end of his five-day visit here that with the transponders it would be possible to allot three hours' time to various production centres for the telecast of regional programmes and then switch over to the national programmes for the next two hours till 10.30 pm.

Mr Gadgil said the "strategically sensitive and politically important" North Bengal region, particularly Darjeeling district, would receive due priority in equipping relay centres with production units. The first priority would be given to state capitals under the Seventh Plan.

Earlier, addressing civic receptions accorded to him by the Darjeeling Municipality and Nepali Sahitya Sammelan, Mr Gadgil said he would convey to the Centre the various facilities sought by them. Mr B.K. Pradhan, municipal chairman, and Mr R.P. Lama, Sammelan president, had sought Central finance for producing documentary films on Darjeeling using local talents, research and publication of literary works and the establishment of a central news service agency here.

Mr Gadgil also told various delegations including the Welfare Association, that the Kurseong TV relay centre was being upgraded from 1 KW to 10 KW strength which would be operational by January. He, however, said nothing could possibly be done to ensure proper reception in the areas of Darjeeling, blocked by mountains.

CSO: 5550/0114

INDIA

## HINDU CABLES EXPANSION PLANS DETAILED

Calcutta THE TELEGRAPH in English 10 Tun 85 p 6

[Text]

Calcutta, June 9: Hindustan Cables Limited, a government of India undertaking, has undertaken expansion and diversification schemes estimated at Rs 231 crores inclusive of carryover of Sixth Plan schemes, for building additional capacities during the Seventh Plan (1985-90). Currently, negotiations are in progress with the World Bank for financing the foreign exchange component of Rs 94 crores out of the total Rs 231cr under its 9th telecommunication loan.

The chairman of the company, Mr S.K. Roy, said here on Friday that tenders for selection of the technical collaborators for the fibre optics project will be opened in the middle of July. The site has not been finalised. However, he added that several sites are being considered and they include Bhimtal and Dehra Dun in UP, Bhubaneswar in Orissa and Budge Budge and Jalpaiguri in West Bengal.

The potential collaborators for the fibre optics project, according to Mr Roy, are Corning of the US, Standard Telephones and GEC of the UK, Sumitomo Corporation (Japan), Philips, (Holland) and Siemens AG (West Germany) among others.

This project for setting up of manufacturing capacity of 40,000 fibre-km and associated optical line system is proposed at a cost of Rs 28.67 crores with a foreign exchange component of Rs 12.42 crores. The project cost covers civil works, plant and machinery, engineering and project management including know-how transfer and R&D tieup.

He further informed that the fibre optics facilities will be completed in three phases. Phase one, which would be ready 15 months from the date of approval, would involve cabling of imported fibres, assembly of line terminals with fully imported pretested line system products. Phase two and three, to be completed 27 months from the date of approval, would involve fibre drawing and cabling for optical line system, preform making, complete fibre optics system and updating R&D facilities and training.

Besides, the company has taken up a 30 lakh conductor-km project in Jaunpur, UP, for the manufacturer of jelly-filled cables. The revised capital cost of this project is now estimated

at Rs 65 crores with a foreign exchange component of Rs 33 crores.

Other projects include, conversion of the paper insulated cables to jelly-filled cables at Rupnarainpur, modernisation of the Hyderabad unit and development of R&D activities at a cost of Rs 15.74 crores, Rs 12 crores and Rs 10 crores respectively.

During 1984-85, the company's production from Rupnarainpur and Hyderabad units was 31.55 lakh ckm and the sales was worth Rs 143.80 crores. The profit before tax improved to Rs 9.16 crores against Rs 8.47 crores.

The company's new unit at Hyderabad with a capacity of 30 lakh ckm set up at a cost of Rs 70 crores started commercial production in March 1985 and is expected to save Rs 30 crores in foreign exchange on attainment of full capacity.

In the meantime, the company has set a production target of Rs 600 crores and a profit of Rs 40 crores in the terminal years of the Seventh Plan.

CSO: 5550/0111

INDIA

JOINT VENTURE TO MANUFACTURE TELECOM EQUIPMENT

Calcutta THE STATESMAN in English 4 Jun 85 p 1

[Text] THE West Bengal Government has decided to start a joint venture with the Birlas for the manufacture of electronic tele-communication equipment, it is officially learnt. WEBEL and TEXMACO are to collaborate on setting up the joint sector unit which will initially produce digital telephones and electronic private automatic branch exchanges (PABX).

The total cost of the project is likely to be Rs 20 crores. The unit, it is learnt, will be set up in the Salt Lake electronics complex. To start with, it will manufacture 500,000 digital telephones and 50,000 PABX annually. The unit, to be taken as WEBEL-TEXMACO, will employ about 600 people, a large number of them engineers.

The new company will soon enter into an agreement with a French firm, called Jeumont-Schneider, for the transfer of technical know-how for the manufacture of the electronic PABX. The agreement with the French firm is likely to be signed by the end of this month. Arrangements are also being made for training the employees both in India and in France. For the import of technical know-how for the manufacture of digital telephones, negotiations are going on with a number of foreign firms.

In the proposed firm, WEBEL will hold the majority equity share of 26% and TEXMACO will have 25%. The rest of the 49% equity will be distributed among the public. Though WEBEL will have the majority share, TEXMACO will look after the day-to-day management of the firm. It may be recalled that WEBEL is a subsidiary of the West Bengal Industries Development Corporation, a West Bengal Government undertaking. The chairman of TEXMACO is Mr K. K. Birla, the well-known industrialist.

The construction of the factor is expected to start this year and production will begin early next year. The letter of intent for the project had initially been given in the name of WEBEL. An application has already been made to the Centre for transfer of the letter of intent in the name of the new joint sector firm.

CSO: 5550/0112

JPRS-TTP-85-019  
1 August 1985

PAKISTAN

BRIEFS

'ADVANCED STAGE' SATELLITE PLANS--The Space and Upper Atmospheric Research Commission is carrying out a study of the effects of rainfall in different areas of Pakistan on satellite transmissions as part of a number of preliminary steps in the implementation of the Paksat project. ASSOCIATED PRESS OF PAKISTAN says plans to place a Pakistani domestic communications satellite in earth orbit around 1988 have reached an advanced stage and detailed design and feasibility studies on all aspects of the project have already been completed. [Text] [BK291040 Karachi Domestic Service in English 1005 GMT 29 Jun 85]

CSO: 5500/4739

1 August 1985

## INTER-AFRICAN AFFAIRS

## BRIEFS

PANA APPOINTMENTS--Dakar, June 24 (AFP)--A three-member management committee has been appointed to run the PAN-AFRICAN NEWS AGENCY (PANA) on an interim basis while the organization continues to wait for a new director, informed sources said here today. The committee is to be headed by Abraham Dagash, 41, of Sudan, who is the deputy director of the Organization of African Unity Information Division, the sources said. The committee is to run PANA until a meeting of OAU information ministers scheduled for Cairo next November 19-21 can elect a director to replace Cheick Ousmane Diallo of Niger, whose term in office expires on Sunday. The sources said Mr Dagash would be assisted by Alfred Opuor, professor of mass communications at Lagos University, and a second person to be chosen by the United Nations Educational, Scientific and Cultural Organization which has contributed financially to PANA. The sources said the decision to create the three-member committee was taken by the chairman of the council of OAU information ministers, currently Egypt, in consultation with the OAU Secretariat. The sources said Mr Diallo would hand over control of PANA to Mr Dagash on July 8. [Text] [Dakar PANA in English 1848 GMT 24 Jun 85 AB]

CSO: 5500/167

DJIBOUTI

SATELLITE EARTH STATION INAUGURATED

AB252200 Paris AFP in French 1905 GMT 24 Jun 85

[Text] Djibouti, 24 Jun (AFP)--Mr Hassan Gouled Apidon, president of Djibouti, inaugurated on Monday the nation's second satellite communication earth station, specially made for use by ARABSAT, and a center for research and utilization of renewable sources of energy, mainly based on solar energy.

This double inauguration ceremony takes place 3 days before the celebration of Djibouti's eighth anniversary of independence.

Only five stations are currently functioning in the 22 Arab countries listed for the exploitation of the two ARABSAT satellites launched into orbit by the rocket Ariane on 7 February last and the shuttle Discovery on 10 June. The other four stations are sited in Bahrain, Jordan, Tunisia and Saudi Arabia.

Djibouti's financial contribution of \$4 million out of a total investment of \$334 million was provided by the Arab Fund for Socioeconomic Development. It will be recalled that Djibouti's first earth station, which uses the American INTELSAT satellite, has been operating since 1980.

On the other hand, the center for renewable sources of energy, which mostly operates on solar energy, was financed with \$890,000 in aid provided by the American Agency for International Development (USAID).

CSO: 5500/170

MADAGASCAR

BRIEFS

TASS, ANTA COOPERATION--Moscow, 4 Jul, TASS--The news agency of the Soviet Union (TASS) and Madagascar's national news agency ANTA today signed a protocol on expanding cooperation in the sphere of information. The document was signed by TASS director general Sergey Losev and Pierre Simon, [name as received] minister of information, ideological orientation and cooperatives of the Democratic Republic of Madagascar. [Text] [Moscow TASS in English 0940 GMT 5 Jul 85 LD]

CSO: 1812/282

MOZAMBIQUE

BRIEFS

PACT WITH IPS--Maputo, 18 June (AIM/PANA)--The MOZAMBIQUE NEWS AGENCY (AIM) and the Rome-based agency INTER-PRESS SERVICE (IPS) yesterday signed a new agreement in Maputo, widening the cooperation between them. As well as the exchange of news services, AIM will now use the IPS communications network for its correspondents and bureaus outside the country, for the exchange of news with other agencies, and for the transmission of daily bulletins to Mozambican diplomatic missions abroad. The agreement also includes clauses related to professional training and technical assistance. The agreement was signed in the presence of the Mozambican minister of information, Jose Luis Cabaco, by the chief news editor of AIM, Fernando Lima, and by the coordinator of the IPS network, Mario Dujisin. IPS is a journalists cooperative, specialising the Third World problems. Its first agreement with AIM was signed in 1977. [Text] [Dakar PANA in English 1011 GMT 18 Jun 85 AB]

CSO: 5500/167

NIGERIA

BRIEFS

**ARMY SCHOOL HEAD ON COMMUNICATIONS**--Lagos June 28 (NAN)--The commandant of the Nigerian Army School of Signals, Lt Col Michael Alao, yesterday in Lagos urged developing countries intending to acquire satellite communications systems to find ways of protecting them from outside interference. Delivering a keynote address at the 1985 annual conference of the Nigerian Union of Planetary Radio Science, he said that recent events had shown that military operations were entirely dependent on reliable, efficient and secured communications systems. He said that over-dependence on the advanced countries for the supply of communications equipment was likely to affect the success of military operations in developing countries, adding that adequate steps should be taken to minimize the problems of frequency management, manpower shortage and electronic warfare. The two-day conference is jointly organized by the Geophysical Association of Nigeria, Nigeria Association of Geodesy and the Nigerian Association of Radio Science. [Text] [Lagos NAN in English 1623 GMT 28 Jun 85]

**GOVERNMENT TO CHANGE TV AUTHORITY**--The general structure of the Nigerian Television Authority, NTA, is to be abolished and the authority's section channel seven at (?Shogbo) in Lagos is to be moved to Abuja. These are parts of the decision taken by Federal Military Government on the report of the committee set up in October last year to look into the rationalization of the service of NTA. A white paper published in Lagos today says that the government also accepted the committee's recommendation that NTA transmitters and terrestrial links in the state should continue to exist and be operated by the authority. [Excerpt] [Lagos Domestic Service in English 21 GMT 8 Jul 85 AB]

CSO: 5500/171

SOUTH AFRICA

VIEWERS FUND CISKEI TELEVISION STATION

Port Elizabeth EVENING POST in English 5 Jun 85 p 11

[Article by Graham Fysh]

[Text]

AMERICAN television viewers have given \$750 000 (R1,5 million) toward a full-time Christian television station being built in Ciskei.

The station, being constructed by the Trinity Broadcast Network (TBN), headquartered in California, will broadcast from Windy Ridge, near Bisho, as soon as the South African authorities allocate a channel from which it can operate, TBN says.

It will be the first full-time Christian television station in Africa, according to TBN.

A total of \$25 000 (R50 000) for the transmitter building — which has been built on Windy Ridge — was sent to Ciskei in mid-May.

Now TBN has raised an additional \$750 000 (R1,5 million) for the transmitting equipment. A special road had to be built to the transmitter site and cable to provide the power had to be laid down.

The money was raised during a week-long "Praise-a-thon" during

which viewers were asked to send in money for various TBN projects, including the use of a satellite to transmit programmes across the United States.

A total of \$30 million (R60 million) was raised during the week.

About three hours of programming on one night during the week was devoted exclusively toward raising money for the Ciskei transmitter. Viewers were invited to telephone the station and pledge money toward the project.

Calls came into the station at a rapid rate and the programme organisers excitedly called out the pledges that were being made: "\$1 000... \$500... \$120 a month... \$10 000..."

Within the three hours more than the requested \$750 000 had been raised.

During the programme, video film of the transmitter building being erected on Windy Ridge was shown.

Also featured in the video was Paul Crouch, one of the leading person-

alities on TBN, who flew to South Africa to make arrangements for the broadcasts. With him was Arthur Blessed, a man who has spent many years walking around the world, carrying a cross with him. Some years ago he walked through South Africa.

Crouch said the programmes from TBN would first be beamed by satellite from the United States, but local programming would be added later.

The scenes from Ciskei also featured an interview at the transmitting site with Douw Steyn, Ambassador for Ciskei. He told the television audience that the building of the Christian station was a result of the vision of Ciskei President Lennox Sebe.

Crouch said TBN hoped that this first station at the southern tip of Africa would be the start of a string of Christian television stations across the continent of Africa.

Politics was not discussed during the pro-

gramme. But at one stage Crouch asked Steyn whether the unrest in South Africa had affected the Ciskei. Steyn replied that "in all the time of racial trouble, Ciskei has remained peaceful". He complimented the Ciskeian Government on that.

TBN — which broadcasts around the clock — has a number of outlets across the United States and also has stations in Italy, Guatemala and the Caribbean. All the programmes are directly Christian in content, featuring preaching, singing, talk shows, and Christian music videos.

It is one of the major Christian television networks in the United States, largest of which is the Christian Broadcasting Network (CBN), headquartered in Virginia.

Not all Christian organisations make use of stations such as TBN or CBN. Many, including the Billy Graham organisation, prefer to buy time on regular television networks in order to broadcast their messages.

SOUTH AFRICA

BRIEFS

SABC HEAD DISCUSSES EDUCATIONAL TELEVISION--The director general of the SABC, Mr Riaan Eksteen, says the education mealtime television which begins on 1 September will make a valuable contribution to the demands made of young people by rapid change. He said this evening at a Rapporteurs [Dispatch Riders Afrikaner Youth Organization] meeting at Vanderbijlpark that amazing developments in technological and other fields required a renewed effort to educate young people in broad terms. Mr Eksteen said the SABC wanted to take part in the process of solving the country's problems. He said the SABC wanted to help young people to play a constructive role in building a country in which all groups will have a secure future. The task could only be achieved if the parents accepted co-responsibility and partnership with the SABC. [Text] [Johannesburg Domestic Service in English 1700 GMT 12 Jun 85]

TV3 TRANSMITTER STARTS OPERATION--Johannesburg, June 27, SAPA--The TV3 transmitter at Suidrand, Kroonstad, will start with full-time transmission from July 1, SABC-TV announced today. In a statement, the corporation said the first month would be considered as a test period during which "transmissions may be interrupted without warning or apology to carry out necessary adjustments or repairs." The transmission will be on channel 59 and vertically polarised. Existing VHF receiving antennas, colour coded green or white and presently used for receiving TV1 transmissions, will take the new service. The transmitter will broadcast TV4 after the end of TV3 transmissions at 9:30 PM. [Text] [Johannesburg SAPA in English 0906 GMT 27 Jun 85 MB]

CSO: 5500/168

ZAIRE

ROMANIA OFFERS ASSISTANCE IN TELECOMMUNICATIONS

AB022158 Kinshasa AZP in French 1526 GMT 1 Jul 85

[Text] Kinshasa, 1 Jul (AZAP)—Romania is ready to contribute to the development of telecommunications in Zaire, notably through a greater participation of Romanian enterprises in the implementation of certain projects in the sector which have been planned under the third 7-year term of office of Marshal Mobutu Sese Seko.

This desire of the Bucharest government was expressed by Andrei Mircea, ambassador of the Socialist Republic of Romania to Zaire, who led a delegation of the Romanian holding "Electronum" in talks with N'dokay Kolop'wo, managing director of the Zairian National Posts and Telecommunications Office [CONPTZ]. The delegation, which is in Zaire within the framework of a prospection mission, has visited some technical installations of the ONPTZ in Kinshasa.

Experts of the firm "Electronum" are interested in switching, a sector where the Romanian enterprise has great experience with the construction of gigantic installations in Algeria, Greece, USSR, and other countries.

"Electronum" thus proposes an offer to evaluate the existing exchanges in Zaire and, following that, present equipment for installation.

Ambassador Andrei Mircea repeated the invitation made by his government to posts and telecommunications officials in Zaire to visit Bucharest to hold serious talks aimed at increasing cooperation between Zaire and Romania in this sector.

Citizen N'dokay on this occasion praised the Romanian partners for their desire to cooperate and recalled some priorities of his enterprises during this third 7-year term of President Mobutu.

Rehabilitation of the exchanges in Kinshasa which include proposals for the extension of 5,000 new lines form part of these priorities, stressed the managing director of the ONPTZ who, also emphasized the need to harmonize the existing equipment and that to be installed for better operation.

CSO: 5500/170

1 August 1985

USSR

**IDEOLOGICAL SUBVERSION VIA SPACE****PM271035 Moscow SELSKAYA ZHIZN in Russian 26 Jun 85 p 3**

[APN article written especially for SELSKAYA ZHIZN: "Ideological Subversion Via Space"]

[Text] Reports which, on the pretext of the "free flow of information," propagate in every way U.S. plans to organize radio and television broadcasting for the population of foreign states via satellite are appearing with increasing frequency in the Western press. Radio stations belonging to the United States, the FRG, and other countries persistently give technical instructions on how to receive these transmissions in their broadcasts in the languages of socialist community countries.

As APN has been informed by the competent organs, the realization of these intentions affects the broad problem of states' rights and obligations in the matter of the international use of the mass media.

It is well known that specialists in UN bodies who have studied this question have come to the conclusion that international television broadcasting via satellite opens up enormous potential to increase the level of the population's culture and improve mutual understanding among the peoples.

However, the experts also noted the potential for foreign television broadcasts to have an adverse effect upon people's lives. Account was taken here of the experience of foreign radio broadcasting. As a result of many years of discussion, the UN General Assembly adopted in 1982, on the initiative of the socialist and developing states, "Principles for the Use by States of Satellites for Direct Television Broadcasting." They allow for the relaying of broadcasts via satellite specifically for a foreign population only on the basis of agreements among the broadcasting and receiving states.

This problem has also been discussed by technical specialists in the International Telecommunications Union, which has decided to allocate special wave bands for satellite television broadcasting. So far as the satellite television broadcasting service is concerned, the International Telecommunications Union has decided (and the U.S. representatives in the organization agreed with this) that every state should be assigned a zone to which its satellites may transmit a signal receivable by ordinary television sets. The national principle forms the basis of zone allocation. In other words, a state has the right to organize television broadcasting via satellite only on its own territory, apart from a few cases where a group of countries have agreed to have a single, common broadcasting zone (for example, the Scandinavian countries).

Thus, organizing the transmission of special television programs for the population of foreign states via satellite without the agreement of those states' governments would

be a gross breach of international law, that is to say, the decisions of the International Telecommunications Union and the recommendations of the UN General Assembly.

Certain U.S. lawyers are trying to prove that the principle of freedom of information exists under international law. These claims have no real basis. All questions of disseminating mass information among the population of one's own country fall within the internal jurisdiction of the sovereign state in question. It is no accident that no unanimous opinion regarding this question exists in the United States. The well-known American specialist Professor I. Kristoll considers that if "a state deems broadcasts unacceptable on the basis of its own political, security, or other national interests, it may employ traditional methods of jamming."

The socialist countries do not advocate limiting the freedom of radio and television broadcasting, as the American mass media try to make out. The Soviet Union and the other socialist countries fully support the broad movement in the world to establish a firm procedure for the international use of the mass media on the air waves, including various television channels.

Competent Soviet circles have informed APN that "pirate" television broadcasting via satellite may be regarded as ideological aggression. With all the ensuing consequences. Every state has the right to take measures available to it to counteract illegal television broadcasting, not only on its own territory but in outer space too.

**CSO: 5500/1029**

EUROPEAN AFFAIRS

TELECOMMUNICATIONS R&D PROGRAM 'RACE' IN DEFINITION PHASE

Paris ELECTRONIQUE ACTUALITES in French 12 Apr 85 pp 1, 11

[Article by D. Levy: "The RACE Program Should Be Accompanied by Industrial Projects"]

[Text] The community R&D program on communications technologies (RACE) proposed by the European Community Commission is viewed positively although not uncritically by the French industry and PTT [Post and Telecommunications Administration].

Indeed, these circles are well aware that--like Aesop's tongues--this operation can be for the best or for the worst. For the best, if the developments undertaken jointly by manufacturers' groups find their natural outlet in industrial projects and if the constitution of such groups leads to the emergence of an industrial telecommunications power in Europe. For the worst, if community resources are scattered haphazardly and if individual countries, if not individual manufacturers, are looking out for number one.

Following close on the ESPRIT program [European Strategic Program for Research and Development in Information Technologies], the European Economic Commission took the initiative of proposing to the 10 EEC member countries an R&D program in the field of telecommunications technologies (see ELECTRONIQUE ACTUALITES dated 29 March). The project, called RACE (R&D in Advanced Communications Technologies for Europe), is still not on the same plane as ESPRIT, the latter involving essentially two partners (industry-Commission), while RACE involves a third partner, the PTT.

The latter, having their own strategy and European policy, should indeed have their say in this matter. In France, the PTT--which can hardly be suspected of lacking enthusiasm for European cooperation--declared their dual commitment in this respect: to bilateral and multilateral agreements for the short and intermediate term (for instance, the French-German radiotelephone and the CIT-Alcatel/Italtel/Siemens agreement), and to broader cooperation in the long term, within the EEC.

However, on the latter point the French administration clearly stated that it was in favor of a "reasonable and not oversized" RACE program. Actually, it had to dismiss the Commission's first proposals that were judged too ambitious. "If we had gone along with them, they would have concentrated all our resources on this single program," the PTT explained. But, for them, RACE is "a complement to the national program."

These nuances conceal the French administration's determination to retain control of its market, as opposed to the idea of a supranational Europe of telecommunications managed from Brussels (a position that is less popular with the new Commission).

#### Part I Sponsored by the PTT

As a result, preparatory work leading to a "definition stage" of the RACE program has taken a new turn, marked by caution and moderation. The tasks to be accomplished during the 18 months of this definition stage can be divided into two parts: Part I covers the working out of an IBC [expansion unknown]/wideband integrated communications reference model, which would mean that all of Europe would have ground support facilities capable of supporting existing services as well as a variety of new services involving voice, data and image transmission, by 1995; and Part II covers key R&D activities requiring long implementation periods, but necessary for immediate evaluation and technical-economic analysis.

It was decided that Part I would be tackled under PTT direction. Indeed, the latter are responsible for defining a strategy of evolution toward wideband networks, taking into account existing facilities, current developments leading to the narrow-band ISDN [Integrated Services Digital Network] (which are far from convergent as far as Europe is concerned) and cable plans (for which France has chosen a star configuration and fiber optics whereas the FRG decided in favor of coaxial cables). The CEPT (European Post and Telecommunications Conference), which has created a "special wideband group," is preparing standards in this field and was invited to make a contribution to the RACE definition stage.

Initially, the reference model will be in the form of operational and functional specifications for a wideband integrated communications network (IBC). The model will have to consider the three major aspects of the IBC: the network itself (functional specifications describing a hierarchy of systems and subsystems capable of providing the services identified; definition of specifications and technical standards for interfaces and switching and signalling subsystems); the environment of terminals (requiring the definition of a reference structure or model for terminals outlining optimum standardization; terminals will range from simple portable devices connected to the network via radio to sophisticated professional workstations); and the evaluation of future applications (in particular an assessment of the services that could be offered by a wideband network in the 1990's, and a market analysis).

## A European Force

Part II of the RACE program definition stage focusses on the technological effort necessary to achieve the cost/performance goals required for the implementation of the IBC until 1995. The approach to this part would take the form of transeuropean cooperation. It is practically certain that the same formula would be used as for the ESPRIT program (participation of manufacturers from several countries to a joint project financed 50-50 by the Commission and by the manufacturers).

For this second part, eight domains were defined and will be the subject of exploratory R&D work on the most promising technological options: ultra-high-speed integrated circuits, high-complexity integrated circuits (especially for signal processing), integrated optoelectronics, wideband switching, passive optical components, components for long-distance high-thruput links, specialized communications software, wide flat-screen displays.

Faced with the Commission's initiative in favor of the RACE program, manufacturers reacted very positively, viewing the operation as a means to consolidate their positions while preparing the "network of the day after tomorrow." In France, however, and more precisely in the Alcatel-Thomson group, the appointed national telecommunications champion, it is felt that the advantage of the RACE program is that it outlines the constitution of an industrial force "among those manufacturers who feel closest," leading to investment economies as far as systems development is concerned (as systems costs are now no longer on a single-country scale) and to increased consultation with international organizations, leading to product standardization. However, R&D work and incipient European cooperation would not be very promising if it were not for the underlying solid industrial projects from the PTT. To the extent that these projects would materialize, the RACE program would assume its full significance.

After the rapprochement between CIT-Alcatel and Thomson-Telephone at national level, we can now see the beginning of a European regrouping between Alcatel-Thomson, Italtel and Siemens (to be joined by Plessey later this month), in particular to cooperate on the future ISDN cards. One need not be a genius to detect in this group the hard core of a European telecommunications force. Certainly, the relations of this group with other international and national manufacturers (in France, in particular, SAT [Telecommunications Company] and CGCT [General Telephone Engineering Company]) will have to be defined. As far as international manufacturers are concerned, we should distinguish the cases of IBM, ITT and Philips-AT&T. Involved in preparatory work on RACE were the 12 European telecommunications manufacturers, (including a representative of Philips-AT&T), representatives of the PTT and of the Eucatel professional union organization (one member of SI3T [expansion unknown] and another from BTM [expansion unknown], the Belgian subsidiary of ITT). IBM, therefore, did not participate. The European ITT subsidiaries do not seem to be the object of any discrimination, but there appears to be difficulties in the case of Philips-AT&T: many participants see the tandem as an AT&T beachhead in Europe.

9294

CSO: 5500/2674

AGREEMENT SIGNED ON USE OF EUROPEAN 'OLYMPUS' SATELLITE

Paris AFP SCIENCES in French 30 May 85 p 18

[Article: "ESA-EBU Agreement on the Olympus Direct TV Satellite"]

[Text] Geneva--European direct television broadcasting just took another step forward when, on 28 May in Geneva, the ESA [European Space Agency] and the European Broadcasting Union (EBU) signed an agreement concerning the use of the Olympus satellite scheduled to be launched in 1987.

The Olympus satellite, whose total cost is estimated at 625 million accounting units (approximately \$500 million) was financed through the ESA by the Austrian, Belgian, Canadian, Danish, Italian, Dutch, Spanish and British governments. It is one of the many pre-operational projects undertaken by the ESA in recent years, others being the OTS [expansion unknown], Meteosat 1 and 2 and ERS-1 [European remote-sensing] satellites.

With this satellite, the ESA intends to demonstrate that it is possible to put into orbit a heavy satellite that will become a versatile platform for a series of future applications in the field of telecommunications and in particular in that of direct satellite broadcasting and television, under competitive conditions worldwide.

Under the agreement, four radio-TV broadcasting organizations belonging to the EBU--ARD [Working Group of FRG Broadcasting Institutes], NOS [Netherlands Broadcasting Foundation], RTE [Irish Radio and Television] and RAI [Italian Radio and Television]--formed a consortium and, as an experiment, will have free use of Olympus for three years to broadcast a paneuropean television program and complete technical tests. Under a previous agreement, one of the satellite repeaters had been placed at the disposal of the RAI; the other organizations will share the second. But all experiments will be planned and coordinated by the EBU.

The paneuropean television program--the so-called Olympus program, designed, prepared and financed by the 4 above-mentioned organizations for 4 years--will be broadcast over increasing periods during the 3 years considered (3 hours during the first year, 8 hours during the second year and 10 hours during the last year).

To enable the participants to acquire some experience before Olympus is placed into orbit, the consortium will broadcast a 5-hour daily program to European cable networks between 19:00 and 24:00 hours, through the ECS European communications satellites of the Eutelsat European communications organization.

The Olympus program will consist of TV material supplied by EBU members that may or may not belong to the consortium, or purchased from other sources, including Eurovision material and material supplied by the EBU.

In addition, on 24 May, Eutelsat suggested that the existing national TV satellites, when they reach the end of their lifetimes, around 1992, be relayed by a joint program involving several European countries: a single direct-TV satellite with 12 to 20 channels and covering all participating countries could thus replace the first-generation direct-TV satellites.

9294

CSO: 5500/2678

EUROPEAN AFFAIRS

SEVEN FIRMS IN JOINT SECOND-GENERATION 'EUTELSAT' PROPOSAL

Paris AFP SCIENCES in French 6 Jun 85 pp 30-31

[Article: "Joint Offer From Seven European Companies for 'Eutelsat' Second-Generation Satellites"]

[Text] Paris--The seven largest European telecommunications companies--Aerospatiale, Aeritalia, Alcatel-Thomson Space, ETCA [Central Technical Establishment for Armament], Ericsson, Marconi Space Systems and MBB-Erno [Messerschmitt-Boelkow-Blohm/Erno]--have announced that they were working on a joint proposal for the realization of second-generation "Eutelsat" satellites.

According to a communique from Aerospatiale, the French company will be the leader of this team of European manufacturers, which is planning to answer the call for bids published on 26 January by Eutelsat, the European satellite telecommunications organization, concerning the construction and launching of three second-generation satellites, the first of which should be placed in orbit by mid-1989.

The joint proposal, to be submitted to Eutelsat this month, is viewed in expert circles as an interesting approach, politically and technically, on the part of these firms which, until now, seemed rather inclined to engage into fierce competition. It shows that their managements have become fully aware of the need to regroup and pool their efforts now that sales have slowed down as a result of technical progress and increased satellite manufacturing costs and insurance premiums.

The satellite proposed by the six [as published] companies would be based on the "Spacebus 100" platform that was already used, in particular, for the "Arabsat" satellite which was placed into orbit for the first time a few months ago.

The firms associated for this proposal have much experience: over the past 20 years, they have launched a total of over 35 satellites and participated in all major European and international telecommunications projects.

9294  
CSO: 5500/2678

EUROPEAN AFFAIRS

BRIEFS

EUROPEAN PUBLIC-SWITCHING RESEARCH--On 25 April in Paris, four major European telephone manufacturers, CIT-Alcatel (France), Italtel (Italy), Siemens (FRG) and Plessey (Great-Britain), officially signed the agreement in principle arrived at last January, covering research collaboration. The partners intend to pool their R&D efforts on basic subassemblies for public-switching systems, such as subscribers' hookup circuits and associated components. Work has already started on subscribers' cards and on the definition of an international interface standard for the next generation of exchanges. Four new areas of collaboration are currently under consideration: subscribers' access, management and maintenance centers, operators' centers, and software development tools. The benefits expected from this cooperation are a reduction of research costs, an improvement of overall performance, a contribution to the definition of European or international standards, and a reduction of component costs through standardization, CIT-Alcatel pointed out. Under the five-year agreement, the four partners will contribute equal amounts toward the cost of studies, each company remaining in charge of its own personnel. A technical coordination committee will monitor the progress of joint studies and, if needed, may decide to initiate additional work.  
[Text] [Paris AFP SCIENCES in French 2 May 85 p 44] 9294

CSO: 5500/2667

BELGIUM

SIX FIRMS VIE FOR HUGE TELEPHONE CONTRACT

Zurich NEUE ZUERCHER ZEITUNG in German 19 Jun 85 p 14

[Article: "Fight for the Contract of the Century for the Belgian Regie des Telephones"]

[Text] Brussels, 17 June--It is possible that the Belgian government must make the most important decision in financial terms shortly before the parliamentary elections in December. It involves the renovation of the telephone network. The contract being sought by six companies is worth between 58 billion and 150 billion Belgian francs depending upon which technical solution is ultimately chosen.

Problems that are not so much technical as political are the reason why the contract has been discussed for months without its size even being clear. Originally, the telephone exchanges were to be replaced by up-to-date digital systems. The only suppliers being considered were Bell Telephone and GTE-Atea, with whom the Belgian Regie des Telegraphes et des Telephones (RTT) has been cooperating for decades. As everyone knows, there is practically no true competition in these large public contracts. Every country endeavors to take care of its domestic industry despite an EEC resolution to open these markets gradually. In the case of Belgium, the matter is complicated because this time Wallonia wants to have a piece of the cake, whereas the two traditional suppliers are active mainly in Flanders. Wisely foreseeing political adversity, Bell made a timely effort to bring in a Walloon company. A year ago, an agreement was reached with the Ateliers de Constructions Electriques de Charleroi (ACEC) that involved research, production and export. But the dominant position of ITT subsidiary Bell in commutators, the actual telephone exchanges, was not to be touched. Bell holds about 80 percent of the Belgian market for telecommunications installations and wants to use the large contract to recoup a portion of the development costs for the new System 12.

## Walloon Game of Hide-and-Seek

But the ACEC are playing a double game, having entered into a contract with the Swedish company Ericsson shortly after the agreement with Bell. Since they themselves do not have a system for telephone exchanges, they were to take over the technology from Ericksson. This agreement meant that the ACEC would disloyally be competing with Bell in Bell's very own terrain. Bell acted accordingly and terminated the contract with the ACEC. But that was not all, for other competitors have arrived in the form of Siemens, Philips and the CGE-Thomson subsidiary CIT-Alcatel. Whereas Siemens and Philips are represented in Belgium by factories, CIT-Alcatel has only a sales office and therefore cannot compete for a share of the multi-billion franc project by presenting arguments to the state concerning favorable effects on domestic additions to value and the balance of trade. In this area, Bell is clearly in the best position. The company can refer to large orders from China and Turkey, which improve not only the business of the Belgian subsidiary but also the balance of trade. The word of warning is that if the new RTT contract is snatched away from Bell, then the financing of the costly research could be put in question. It is estimated that other suppliers who, in turn, cover research outlays through the domestic market, could deliver for up to 30 percent less. This would apply for Ericsson, for example.

## Renewed Harmony

After the ACEC were taken over by a company that Belgium's largest holding company Societe Generale founded jointly with CGE-Thomson, the chances for an internal Belgian agreement again became somewhat greater. Indeed, last week Bell entered into a new agreement with the ACEC. The conflict of interest is now to be eased by increasing the size of the cake. The two reunited partners are proposing to the government or to the RTT that now not only the telephone exchanges but also the telephone lines should be renovated to proceed with the incorporation of the conversion to an integrated digital network (ISDN). In this case, the exchanges would be reserved to Bell and the ACEC could take over the lines. To be sure, the contract would no longer cost 58 billion Belgian francs but about 150 billion francs. If the state can come up with this gigantic sum, then there would be sufficient latitude for a certain participation by the other competitors. If the government were to accept the expansion of the contract, then, after much vacillation, at least the basic decision could be reached before the elections.

## Europeanization of Bell

Meanwhile, the ITT is striving to improve the chances for the participation of its subsidiary in additional European projects.

The announcement that some of the Bell shares are going to be sold can be explained not only by the desire to maintain liquidity to reduce indebtedness but it also involves giving Bell a European image by bringing in a partner. In view of the increased research efforts of the EEC, this is becoming increasingly important for Bell. In the EEC program for information technology ESPRIT, the firm has already had the bad experience that it, as a U.S. subsidiary, does not have the best prospects for being awarded a contract. With the RACE program, which serves the development of a wide-band telecommunications network, the way is being paved for a deal for the latter half of the decade that will eclipse every national contract. Bell does not want geopolitical reasons to obstruct a potential participation, for which it is best prepared from the technological point of view. It is a reasonable assumption that the conversation with the Societe Generale involved not only a renewed cooperation with the ACEC but also a capital participation. So far, however, there have officially been no agreements. On the other hand, Albert Frere, financial strategist and chief of the Groupe Bruxelles Lambert, has declared his interest in taking over the minority interest in Bell. The GBL is strongly involved in the audiovisual area, especially through its participation in the radio sender RTL. In view of the technically conditioned growing together of data processing, telecommunications and audiovisual media, it seems appropriate for Frere to buy into Bell. The ITT subsidiary would thus obtain an influential Belgian partner.

9746  
CSO: 5500/2666

DENMARK

## OPPOSITION TO HYBRID NETWORK MAKES REALIZATION UNCERTAIN

Copenhagen BERLINGSKE TIDENDE in Danish 31 May 85 p 12

[Op Ed Article by Knud Lindholm Lau, Reporter for Danish National Broadcasting Company: "Massive Opposition to Hybrid Network"]

[Text] Parliament is considering today the changes in the law which are necessary to enable the telephone companies to construct the hybrid network. Particularly the provisions that TV signals may not be transmitted across municipal boundaries have been a hindrance for the expansion of the light-conductor system.

But the network is far from a reality. Apparently the majority of the politicians and telephone companies have been convinced of TV-viewers' interest in the many channels, but they likely will be surprised.

The hybrid network consists of a combination of the public light-conductor network and the municipally- or association-owned copper network. The whole idea, therefore, is premised on the fact that the antenna associations will purchase TV signals through concessions offered by the telephone companies. No one has researched the interest in this prior to Parliament making its decision and prior to the telephone companies commencement of construction of the network.

The chairmen of the antenna associations in North Jutland gathered for a meeting on 7 May in Hjallerup in a general meeting of the North Jutland shared antenna group, SANA. With a view toward a radio broadcast on Monday, I took advantage of the opportunity to have a survey done of the attitude toward the hybrid network.

Jydsk Telefon [Jutland Telephone Company] is going to have a very difficult marketing job. Half of the associations already have decided at general meetings not to connect up with the hybrid network. These associations cover 63 percent of the members of the associations which were surveyed. The remaining groups have yet to take a position. None has decided as of now to join the network.

The hybrid network's TV signals come from the so-called communications satellites, from which signals may not be received by private individuals here in Denmark. If the direct-transmission satellites are launched as is planned for next spring, the antenna associations will be able to obtain

more TV programs by putting up disk antennas instead of connecting to the hybrid network. This would not provide the same programs, but in exchange, the solution is far cheaper.

Seven out of 16 associations--accounting for 60 percent of the viewers in the survey--already have decided to put up such a disk antenna. An additional seven, covering 33 percent of the viewers, are awaiting the launching the direct-transmission satellites. The majority of the representatives of these associations expect that the directors will recommend the disk antenna solution.

One must take into consideration that the North Jutland association of antenna groups was formed in protest against the plans for the hybrid network, but it covers, practically speaking, all facilities except the municipally-owned ones. From a marketing point of view, therefore, the results should be accurate enough.

Only a portion of the country's joint antenna facilities are owned by associations and therefore, there can be a remaining market within the municipally-owned network. Notwithstanding that the inertia principal must be considered, the municipalities hardly will give higher priority to TV systems in preference to health care facilities during stringent times, and in any case, financing will complicate problems as long as tight lending conditions continue.

On the other hand, the individual municipalities are nervous about perhaps being the last one to sign up. The telephone companies can relate to this. It is therefore possible that many municipalities will build large public networks in virgin areas in order to create a basis for the telephone companies' marketing of TV programs. "The light-conductor system, however, will come quickly to our town, and the local business community will not be left in the lurch," is how the argument goes. A municipal common antenna network which would cover the entire city and cost 55 million kroner already is on the drawing board in Herning.

By considering the matter today, Parliament will be unable to guarantee society against superfluous investments for the construction of the network for which there is no need. Nonetheless, the light-conductor network likely will be built anyway, say the telephone companies. It is being laid down between central telephone offices and expanded further according to the needs of the business community irrespective of the marketability of the TV signals. The investments in connection with allocations for TV, however, are double the amount which should be spent in any case. It would, therefore, be appropriate if the telephone companies were challenged politically to go cautiously.

It is said that with the erection of disk antennas there is the risk of duplicative investment. But the worst investment really is one for which there is no use.

12578  
CSO: 5500/2661

DENMARK

AGENCY TO INAUGURATE ELECTRONIC MAIL NETWORK THIS YEAR

Copenhagen BERLINGSKE TIDENDE in Danish 30 May 85 Sect III p 12

[Article by Sv. Aa. Jensen: "Post & Telegraph Ready Soon With Electronic Mail"]

[Text] In the course of the next few years, more than a third of the daily quantity of mail--which is about 3-4 million--will go through the air and arrive the same day.

During 1985, the postal service will begin to send business letters electronically. It is assumed that P & T [Post and Telegraph] will allow a third of the daily mail--which is somewhere between 3 and 4 million pieces--to be sent electronically within a few years and the only delivery will be by a delivery person at the receiving post office.

"I am counting on the fact that electronic mail transmission will be so inexpensive that the postage for the type of business letter which is suited for sending electronically--namely, mass mailings--can be reduced very significantly," states Kjeld Nykjaer Petersen, the director of P & T's production-development office.

"To be able to send one million of these letters electronically at one time will enable us to save not only a lot of transportation costs, but also much sorting labor, since the data and telecommunications network which will be used for these transmissions also will be able to sort the letters according to postal zones by number. We have come so far in testing that the new project will be presented to top management of P & T one of these days."

Facilities in Ten Danish Cities

"I am counting on the fact that initially we will place the new electronic centers in Copenhagen and Aarhus. On the longer term, 10 centers will be established over the whole country, but the new electronic system also can be connected to more simple equipment at the receiving post offices.

"Every household is familiar with the mass mailings which soon will be able to be sent electronically to postal customers. For example, it could be information from banks, oil companies, credit unions and tax information. When something is to be sent electronically, the firms which themselves have advanced technical equipment will need only deliver the magnetic tapes with

the information to the postal service. We will print out the tapes in the cities where the mail is to be delivered and the letters can arrive the same day they are sent.

"We are far advanced in the technical research and electronic letters would already have become a fact today if we had escaped the postal crisis in 1980.

"That resulted in our having to concentrate for a couple of years on getting the economics and quality of mail delivery in order, which to a great extent has been accomplished."

12578

CSO: 5500/2661

1 August 1985

FEDERAL REPUBLIC OF GERMANY

CABINET EARMARKS DM939 MILLION FOR DATA SYSTEMS

DW251208 Hamburg ARD Television Network in German 1100 GMT 25 Jun 85

[Text] The Cabinet in Bonn today adopted a program for the establishment of electronic information systems for specialized data. Through 1988 a total of DM939 million will be earmarked for the program, which was introduced by Research Minister Riesenhuber. The specialized data storage systems are intended to store the scientific, technical, and economic know-how existing in the FRG.

As for the Eureka technology project proposed by France, Riesenhuber said today that the Federal Government rejects the creation of a new European bureaucracy promoting technology that would not have any concrete applicability. Efforts must be focused on the application of technology in Europe for the benefit of the citizens and the national economies.

CSO: 5500/2681

FEDERAL REPUBLIC OF GERMANY

FRG RESEARCH NETWORK 'DFN' PROMOTES DATA EXCHANGE

Duesseldorf VDI NACHRICHTEN in German 15 Mar 85 p 2

[Article by G. H. Altenmueller]

[Text] The objectives of the FRG Research Network (DFN) are to permit smaller universities to use powerful mainframe computers and to help research groups not located in the same area to exchange their findings and to work together. Its working method and first results were outlined on 27 February in the new Berlin offices of this institute for service and infrastructure.

The members of DFN, which was established in early 1984, already include 30 universities, the Max-Planck Institute and the Fraunhofer Society, almost all large research institutions and 12 computer firms. The FRG Ministry for Research is supporting the development of this "alliance of alliances" with DM 55 million up to 1987, according to Minister Riesenhuber. DFN chairman Prof Dr Norbert Szyperski of the Society for Mathematics and Data Processing is quite happy: The idea has been accepted that in the "very colorful world of the computer in science" an open network must be established that permits communication across producer boundaries.

In this, it differs from the European Academic Research Network (Earn) which IBM is making available to the research institutions for a limited period of time and which is currently of particular interest in light of its connection to the U.S. Bitnet. In 1987, the German portion of Earn is to be replaced by DFN. For DFN, the first binding protocol decisions that reflect international standards have been made and that permits not only national, but also international communication. The ideas of the individual European network projects have been tentatively coordinated within the framework of a European Harmonization Action (EHA). The services DFN offers can be divided into four categories. The Dialog (line- or format-oriented) allows scientists to access remote computers from their workplace. For the line-oriented Dialog, DFN is preparing some software PADs (Packet Assembly Disassembly) programs which, when entered into a computer, assume the functions of a hardware PAD (a special terminal offered by the FRG Postal Service) that is inserted

between the terminal and Datex-P. This means that all local terminals connected to a computer can use the Dialog service without additional hardware investments.

Development of DFN's Remote Job Entry (RJE) service, which transmits batched computer programs through the network to remote computers for execution, is based on a nonstandardized protocol. DFN's third basic service is the File Transfer that sends the contents of a file from one computer to another.

Of particular interest for the specific function of DFN is, fourthly, a message service permitting scientists to transmit text communications among themselves (electronic mail). In DFN, a message system is being set up that is organized on a distributed basis and integrates the structure of a variety of existing systems in line with their architectures. DFN plans to define a protocol for the exchange of graphic information among diverse systems that builds on the transmission and network services. In addition, opportunities are to be created for the graphic dialog and the transmission of "documents" within the network.

DFN's current pilot phase meets the computer needs of the universities of the states of Lower Saxony, Schleswig-Holstein and of Berlin. The DFN communications services provide scientists with access to many large mainframe computers, especially the highly efficient Cray computer of Berlin's Konrad Zuse Institute. In December 1984, that part of DFN processed data at the tune of one gigabyte, i.e., about 400,000 DIN A-4 pages. In January 1985, it had grown by 30 percent. Chemists at the two Berlin universities are using the Cray computer, via DFN, to develop models of the structure of chemical compounds and meteorologists to calculate weather models.

The "Jobverbund Nordrhein-Westfalen" [Job Alliance Northrhine-Westphalia] allows several university computer centers to access, through DFN, the powerful computer of the Ruhr University in Bochum.

Reciprocal information and data exchange via DFN forms the basis for subject-specific cooperation of, for instance, high-energy physicists of Cern [European Council for Nuclear Research] (Geneva), Desy [German Electron Synchrotron] (Hamburg) and several universities. Without such a network, physics at small universities would be "dead", noted Dr Peter Holleczeck of the regional computer center in Erlangen.

Concludes physics diplomate Klaus Ullmann, scientific-technical director of DFN: "DFN will provide strong support to communication among scientific groups; research and development results will become available faster and can be exchanged. Most importantly, however, closer collaboration between state-supported and industrial research will become easier."

FEDERAL REPUBLIC OF GERMANY

## DBP DESIGNS ISDN SYSTEM ACCORDING TO CCITT STANDARDS

Heidelberg NACHRICHTEN ELEKTRONIK & TELEMATIC in German Jan 85 pp 4, 9-11

[Article by Peter Kahl: "ISDN Standards, a Chance and Challenge"]

[Excerpts] During the first half of 1984, the German Federal Postal Service (DBP) submitted plans to strengthen the telecommunications network over the next 20 to 30 years. The goal is to establish an integrated services digital network (ISDN) through a multitude of intermediary steps. Introduction of this network in volume production is expected as early as 1988.

All DBP activities are based on the standards of the CCITT (International Consultative Committee for Telephone and Telegraph). These standards, prepared during the past 4 years in the form of recommendations--the DBP contributed substantially to the results of this work--were adopted by the CCITT plenary assembly in October 1984 and are now in effect. The DBP, with its timetable for introducing the ISDN, is expected to be one of the first telecommunications authorities to implement the CCITT standards.

Figure 1 shows the various phases of the telecommunications network development, as seen today.

Characteristic for this development is, to a significant extent, the application of digital technologies, notably digital transmission and switching technologies in the current telephone network, and the development of a 64 kbit/s ISDN (henceforth to be referred to as ISDN), which is made possible by the use of these technologies. For that purpose, DBP is planning to undertake, in 1986, a pilot project in Mannheim and Stuttgart. Introduction of this network in volume production is planned for 1988.

### ISDN Implementation by DBP

It was pointed out in an earlier paragraph that, in conceptualizing the ISDN, the ISDN subscriber exchange area is the aspect that is truly typical

for the ISDN and the one that must be newly designed. For that reason, further consideration of this paragraph will focus on that area. Figure 2 shows the technical components DBP is currently developing for the first phase of the ISDN and can make available to the subscriber starting in 1988. That figure indicates particularly those components among the various interfaces and basic functions of the devices which have permitted the 100 percent application of CCITT standards. In some of the other interfaces or functions, either no CCITT standards have been developed (such as in the line interface UKO) or the CCITT standards provide options requiring a national selection during implementation from among the diverse internationally agreed options (this was true with the D-channel protocol, the agreed-on signalling protocol between the subscriber installations and the local exchange).

#### ISDN as an Export Article

Apart from the fact that the ISDN standards of the CCITT have been influenced to a large extent by German work and that acceptance of these standards is, therefore, understandable, there are numerous reasons why application of these standards would have been necessary, even if the initial situation had been different. The FRG, as one of the large export countries of the world, must develop in almost all areas, but particularly in the telecommunications sector, installations that are in line with CCITT standards. A large number of countries which are "developing countries" in the telecommunications area and have no telecommunications industry of their own and which, therefore, depend on the importation of telecommunications equipment and where, as a rule, the telecommunications infrastructure is developed to a so-far limited extent, rely in their telecommunications equipment entirely on CCITT standards, using the CCITT recommendations as a type of department store catalog where the desired product only need to be marked with a cross in order to obtain it in accordance with the recommendations. In view of the complexity of modern telecommunication installations and the resulting need to use highly integrated technologies, the economic development of telecommunications products is only possible if the largest possible number of product units of a given device can be manufactured. For that reason, the FRG and hence the DBP must take the greatest pain to use only those products for the development of its own telecommunications network which it (can) offer in the global telecommunications markets and which, therefore, correspond to CCITT standards.

This makes DBP adoption of CCITT standards a twofold blessing: on the one hand, the DBP does not have to produce for special orders and thus benefits from a mass-produced world market product that can be manufactured at correspondingly lower prices, while the DBP network demonstrates, on the other hand, the capability of the German telecommunications industry and helps to promote exports.

However, this opportunity can only be exploited to our advantage if the standards reflect national requirements. To ensure this goal there must be a national concern and it can only be achieved by exerting an active influence on developing the standards. We were successful in doing so when the ISDN was standardized.

#### ISDN as a Challenge

The development of both the ISDN standards by the CCITT and the implementation of an ISDN by the telecommunications authorities--and here especially by the DBP for the area of the FRG--, has created the prerequisite on the part of the network for offering an ISDN with all its advantages and opportunities to the users. Yet the potential uses of this telecommunications infrastructure must be worked out by the users themselves. This makes the ISDN not only an opportunity for the users, but also a challenge. The DBP believes that the availability of the ISDN and the expected introduction of favorable charge structures will lead to a rapid evolution of user applications. The DBP has, of course, some idea of the direction in which the development of these applications may go. But it must not be the responsibility of the DBP to get involved in specific application details. This is a matter for those who use and apply them. The evolution the DBP expects and hopes for concerns primarily the development of new types of terminals and new services. Explosivity in this area will be a significant building stone for the success of the entire ISDN. If the users seize the challenge and make use of the possibilities offered by the network, this can lead to mass application and bring all the advantages derived therefrom. On the other hand, if the users do not grasp the available opportunities or do so only haltingly, this would not mean the end of the ISDN because even then use of the telephone service by the general public is a safe guarantee for its continued existence. Still, the development possibilities that are typical for the ISDN in terms of new services and performance characteristics would then be unable to realize their full potential.

(See Figure 1 and Figure 2 on the following pages)

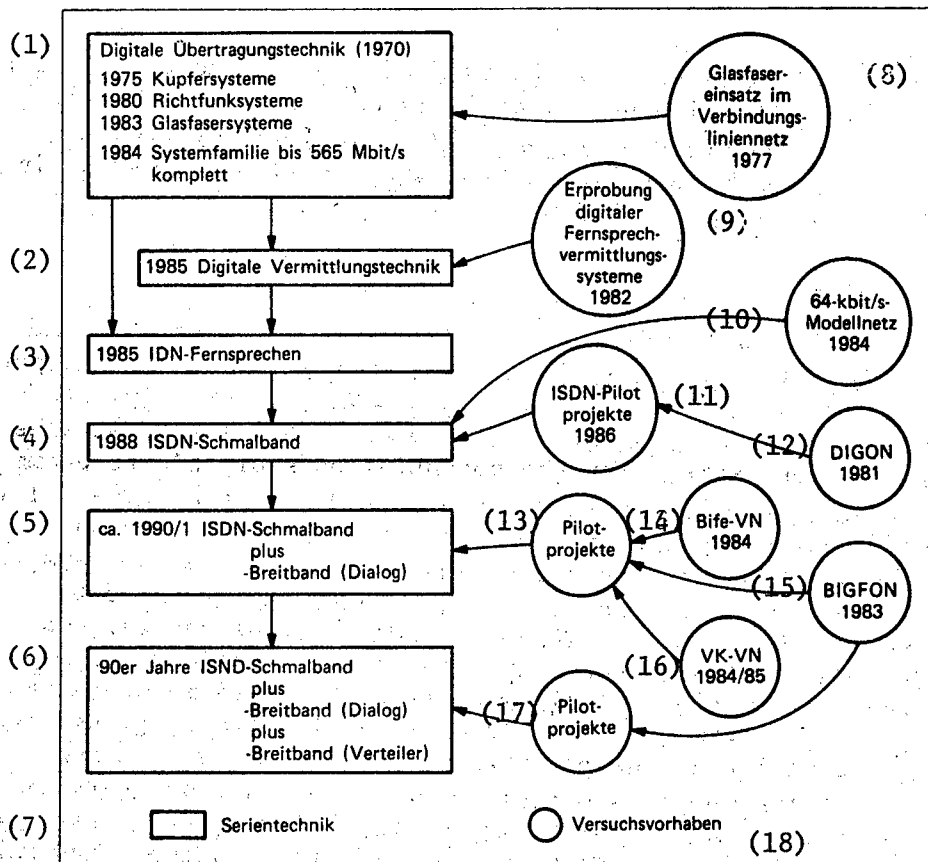

Figure 1 Stages of Development of the Telecommunications Network

- Key:
1. Digital Transmission Technology (1970)
    - 1975 Copper Systems
    - 1980 Directional Radio Systems
    - 1983 Glass Fiber systems
    - 1984 System Family up to 565 Mbits/S complete
  2. 1985 Digital Switching Technology
  3. 1985 IDN Telephony
  4. 1988 ISDN Narrow Band
  5. approx. 1990/91 ISDN Narrowband plus Broadband(Dialog)
  6. 90's ISDN Narrow plus Broad Band(Dialog)plus Broadband (Distributors)
  7. Volume Production
  8. 1977 Glass Fibers in Connecting Lines Network
  9. 1982 Testing of Digital Telephone Systems 1982
  10. 64 kbits/s model network 1984
  11. 1986 ISDN Pilot Projects
  12. DIGON 1981
  13. Pilot Projects
  14. Bife-VN
  15. BIGFON
  16. VK-VN
  17. Pilot Projects
  18. Experimental Projects

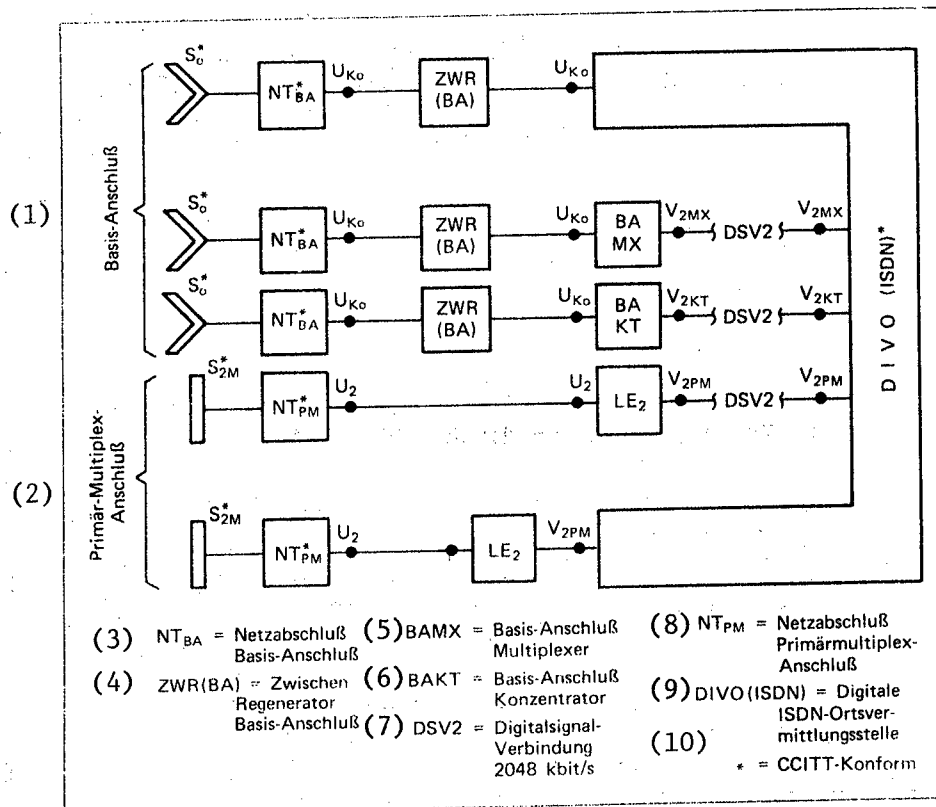

Figure 2 Facilities for Main Connections for ISDN of DBP

Key:

1. Basic Connection
2. Primary Multiplex Connection
3. Network Termination Basic Connection
4. Intermediate Regenerator Basic Connection
5. Basic Connection Multiplexer
6. Basic Connection Concentrador
7. Digital Signal Connection 2048 kbits/s
8. Network Termination Primary Multiplex Connection
9. Digital ISDN Local Exchange
10. Conforms to CCITT Standards

7994

CSO: 5500/2665

FINLAND

SATELLITE TO BRING PROGRAMS FROM OTHER NORDICS' TELEVISION

Helsinki HELSINGIN SANOMAT in Finnish 12 Jun 85 p 14

[Text] Lappeenranta (HS)--The use of communications satellites opens new possibilities in the transmission of Nordic television programs. On Tuesday general manager Pekka Tarjanne promised in Lappeenranta that at best we will be able to watch the other Nordic countries' programs in Finland as early as next winter.

According to Tarjanne, realization of the project will require the smooth cooperation of the radio broadcasting companies and communications ministries and sufficient political determination on the part of the decision-makers.

Sweden and Norway have been the pioneers. A week from now they will begin to transmit Swedish television programs to the Norwegian cable network via communications satellites.

Tarjanne believes that technical, economic, program policy and producer rights issues can also certainly be resolved thinking in terms of even broader cooperation between the two countries.

"If it is successful, the venture would produce both a cultural and technico-economic victory for the Nordic countries and a lot of experience for future ventures."

As concerns touch-tone dialing for telephone networks, Tarjanne said that the whole country would be within range of digital communications by the end of this century. Even thus far, everyone who wants it has received the services he requires.

At the Post and Telecommunications Office (PTL) they react favorably to transforming government agencies into public companies. Tarjanne said that the PTL has added a detailed proposal concerning the PTL's special needs to his own statement.

11,466  
CSO: 5500/2662

## DECISION ON NORDICS' TELE-X NETWORK AWAITS FALL ELECTION RESULTS

Helsinki HELSINGIN SANOMAT in Finnish 16 Jun 85 p 2

[Editorial: "Still More Reports"]

[Text] Hopes of finally reaching agreement on the Tele-X issue have proven to be entirely premature. At a joint conference of culture ministers held in Helsinki they, on the contrary, were forced to admit that they had to again ask officials for new reports because of some unresolved technico-economic questions.

They have been conferring about a Nordic television satellite in different forms for over 20 years. The current version, the Tele-X, is only a modest experimental satellite which would, nevertheless, enable them to offer Nordic programs to all the Nordic countries on the two channels it provides. The project had already drifted into a blind alley last winter when strong pressure from the Nordic Council once again revived the project. Sweden had to make the biggest concessions, but Finland and Norway also had to increase their financial contributions to it.

Having earlier adopted a particularly lukewarm attitude toward the project, these past few months the Finnish Government has been actively looking for a compromise. Norway has remained indifferent to it and Denmark has participated only as an observer. The communications ministries' simultaneous efforts on behalf of a cable-based alternative, which could, however, only be considered in population centers, have complicated the situation.

Requesting new reports of officials means that reaching a political decision on the Tele-X will probably be postponed beyond next fall's elections in both Sweden and Norway. This does not necessarily mean that the project will be scrapped, but the new reports may, on the other hand, require a good deal more.

11,466  
CSO: 5500/2662

FINLAND

BRIEFS

'TELE-X' ADVANCEMENT--At the conclusion of their meeting in Rovaniemi, the Presidium of the Nordic Council appealed to four Nordic prime ministers to speed up the Tele-X project and to have the issue brought before the governments again. The Presidium of the Nordic Council proposed to the prime ministers of Finland, Sweden, Norway, and Iceland that the question of the Tele-X be quickly considered by the Nordic Council. The Presidium's aim is that Tele-X should once again be dealt with by Nordic governments and that the project be given more political weight than before. So far the project has been discussed mostly in official committees. [Text] [Helsinki Domestic Service in Finnish 1600 GMT 4 Jul 85]

CSO: 5500/2682

FRANCE

DECREASE IN ORDERS AT ALCATEL-THOMSON-SPACE

Paris ELECTRONIQUE ACTUALITES in French 12 Apr 85 p 12

[Article by H. Pradenc: "Alcatel-Thomson-Space: Payloads at Low Point"]

[Text] Satellite manufacturers experience periodical drops in business. This phenomenon is currently affecting Alcatel-Thomson-Space, a payload specialist, in particular because the decision on the launching of the TDF-2 program has been postponed, and because the typing of the Athos experimental telecommunications satellite has been thrown back into question. The chances for recovery in 1986 hang on the decisions to be made concerning the Eutelsat and Chinese satellite programs.

Alcatel-Thomson-Space is supplying one tenth of the world market for telecommunications satellite payloads. This line of business, employing 980 people, represented sales of FF 560 million in 1984. Prospects for 1985 amount to FF 800 million. Subcontracting, which accounts for a significant part of the amounts billed, represented about FF 200 million last year. It should account for a larger proportion this year, as the company's Radio-Relay Systems branch is starting to manufacture the Syracuse military telecommunications stations.

FF 20 Billion for European Manufacturers

Alcatel-Thomson-Space which, as is known, is now part of the CGE [General Electricity Company] group, is now carrying out five large programs: Telecom 1, TDF 1/TV SAT, Spot, Intelsat VI and Tele X, the Swedish direct TV satellite. The satellite market, if we except the United States and East European countries, represents a segment in which the European space industry can play a major part, estimated at about FF 20 billion. By the end of the decade, 20 civil-use satellites will have been launched, i.e. more systems than are now in service (about 16). In addition, since lifetime in orbit ranges from 7 to 10 years, there will be an additional replacement market. Prospects for manufacturers, therefore, are interesting. Yet, there is no doubt that 1985 will not be a good year for Alcatel-Thomson-Space.

## Impact on Satellite-Integrating Companies

Workloads at the manufacturer's plants are inadequate, in particular due to the two lacking programs. The Athos experimental telecommunications satellite was thrown back into question and its replacement has not been defined. As is known, a 20-30 GHz payload was to be experimented on this platform; according to Alcatel-Thomson-Space, this is a market niche on which we should not fail to position ourselves, for the Italians and the Germans are getting into it. Another C-band payload experiment designed to increase the Telecom-1 capacity was to have been embarked on Athos. The French administration decided to postpone this experiment. The second program lacking in the manufacturer's order book is TDF 2, a direct TV satellite; the decision to start its construction has not yet been made. A preliminary long-term supply contract (including changes over TDF 1) had been awarded to Alcatel-Thomson-Space and will expire at the end of April 1985.

The problems now experienced by the payload manufacturer will have an impact next year, especially at MATRA [Mechanics, Aviation and Traction Company], whose Space branch, which is in charge of satellite integration in Toulouse, will then experience a workload drop. As is known, this branch achieved 1984 sales of FF 1.25 billion, representing a 180-percent increase over the last 4 years.

For 1986, Alcatel-Thomson is pinning its hopes on two programs for which it joined industrial groups to answer calls for bids. One is a Eutelsat program involving three satellites, the first of which will be launched around mid-1989, and possibly two additional satellites. Eutelsat's decision should be made before the end of the year. As for the two Chinese television satellites, China will soon make its decision public. As is known, Alcatel-Thomson has already gained a foothold on the Chinese market when it recently sold six receivers that will be placed on telecommunication satellites. This is a market worth about FF 20 million.

The manufacturer could also supply Hughes with some of the equipment required for the three satellites ordered by Inmarsat, although it is not a member of the group of manufacturers working on the project, which includes MATRA. This possibility is the result of an agreement signed with the U.S. manufacturer, involving subcontracting work. But since order books are about as thin on both sides of the Atlantic, the agreement signed in 1982 may be difficult to apply.

## 20 Syracuse Stations

In the military sector, Alcatel-Thomson was responsible for the full development of the Syracuse system--space segment and ground segment--which involved military use of two of the Telecom-1 satellite transponders. The first of the 20 or so stations to be manufactured by the company's Radio-Relay Systems branch will be delivered in 1986. According to the company, the second Telecom satellite will be the one to become operational, as its better orbital position will prevent any interference with the NATO and Intelsat systems. No decision has yet been made as to the continuation of this program, but in

any case, the military will have to replace the system which is now being implemented in the early 1990's. As far as the remote project for a military observation satellite is concerned, Alcatel-Thomson--which is contributing to the implementation of the European ERS-1 remote-sensing program--stated that it was prepared to adapt a space on-board radar, working in this field in close collaboration with the Thomson-CSF avionics division.

9294

CSO: 5500/2673

1 August 1985

FRANCE

PTT INVESTS FF 2 TO 3 MILLION IN TELEMATICS, SOFTWARE

Paris ELECTRONIQUE ACTUALITES in French 5 Apr 85 p 10

[Article: "FF 2 to 3 Billion per Year for Telematics"]

[Text] "The PTT [Post and Telecommunications] are now devoting FF 2 to 3 billion to telematics," Mr Mexandeau, minister of the PTT, just indicated in a communication on this subject made at a cabinet meeting.

After recalling that 530,000 "Minitel" terminals were in service last 31 December, 420,000 of which had been given out free under the electronic directory project, Mr Mexandeau stressed that professional demand was "very high" and that new services were being created (over 1,000 in 2 years, 900 of which aimed at businesses), and pointed out that the telematics program provided jobs directly for over 5,000 people.

The PTT made a considerable investment effort for the telematics program: FF 300 million were spent on studies and development, FF 3 billion went to the industry over 3 years for the terminals, hardware and software of the "Teletel" network and of the electronic directory (on 31 December, 700,000 terminals had been ordered from the Alcatel group, 250,000 from TRT [Radio-electrical and Telephone Telecommunications] and 250,000 from MATRA [Mechanics, Aviation and Traction Company]) and FF 150 million had been spent to test and launch telematic services.

"These PTT investments, which now range from FF 2 to 3 billion each year, represent a considerable driving force," the minister pointed out. Service companies invested over FF 1 billion in the purchase of computers and software; French manufacturers acquired an appreciable lead in telematic networks and database query systems; and France acquired a competitive terminals industry.

As far as future developments in the telematics program are concerned, Mr Mexandeau pointed out that, by the end of 1986, the electronic directory will be available in all regions and there will be 3 million "Minitel" in service; the capacity of the directory and "Teletel" access network will be increased fourfold by the end of 1985; and additional services will be offered to users (extended newsstand function, display of call cost by 1986). He mentioned

the availability of electronic funds transfer (50,000 smart-card readers have already been ordered and will be sold in 1986), and the expansion of the terminal line: the basic "Minitel" was complemented by the "Minitel 10" (which includes a telephone, keyboard and screen and an automatic dialler) and will be followed by the future "Minitel 20" (capable of carrying out local processing operations).

9294

CSO: 5500/2673

FRANCE

## EQUIPMENT AT MULHOUSE EARTH STATION FOR TELECOM 1

Paris REVUE FRANCAISE DES TELECOMMUNICATIONS in French Feb 85 p 46

[Article: "Telecom 1: the 'Synchronization Core' is in Mulhouse"]

[Text] The Telecom 1-A satellite, the first link in the French space telecommunications network, has been in geostationary orbit since August 1984. Simultaneously, the Directorate of Foreign-Network Telecommunications (DTRE) set up the ground support facilities required to operate the system. The heart of the whole network beats in Mulhouse, at the Satellite-Telematics Operation Center (CETS).

This network (high-thruput circuits--2.4 kbit/s to 2Mbit/s--and videotransmission services) connects French and European companies. They can exchange "data packets" at the least cost through a switched network using an innovative technology in the field of satellite transmission: time-division multiple access (TDMA) with centralized management. This process requires perfect synchronization between emitting and receiving stations in order to route and retrieve the data belonging to each station. The Mulhouse CETS provides this synchronization and manages the position and time allocated to each subscriber. It is also responsible for the technical control of the network and monitors the overall quality.

### A Three-Headed Structure

To fulfill its various functions, the center uses three types of highly reliable facilities: the reference station, the management center and the remote maintenance center.

The reference station controls all stations in the network. It monitors the satellite through a 6.50-m antenna, a radio-frequency unit, reference terminals (terminals providing references to all the stations using LAPS--logic for shared access to the satellite) and a high-stability atomic clock. Every 1.28 seconds, the movements of the satellite around its nominal position are measured and transmitted to distant stations which memorize them and make the necessary corrections in their emissions and receptions. A diversity center (second unmanned station) located in Feldkirch, 10 km from Mulhouse, fulfills the same functions. It acts as a safety for the main station, especially when local meteorological conditions are unfavorable.

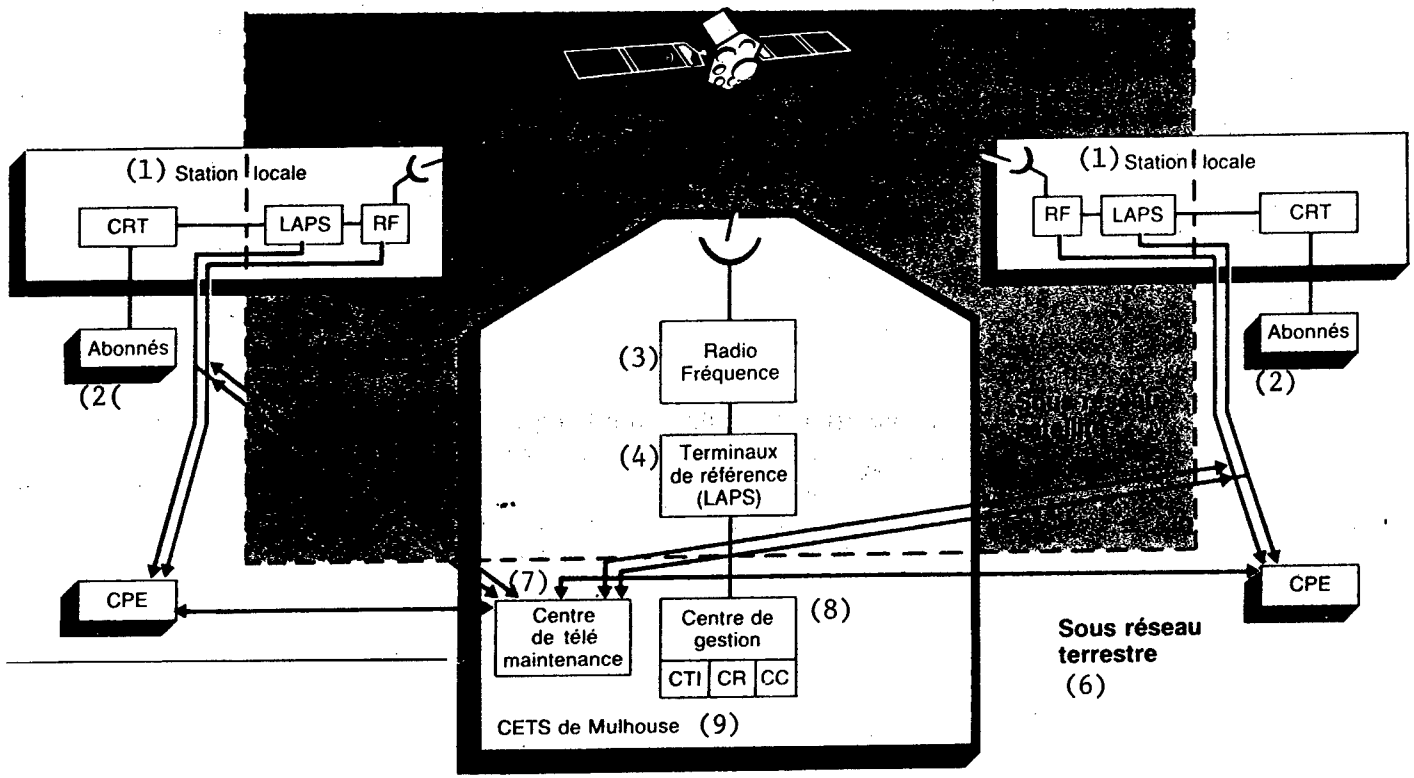

Key:

- 1. Local station
- 2. Subscribers
- 3. Radio-frequency
- 4. Reference terminals (LAPS)
- 5. Satellite subnetwork
- 6. Ground subnetwork
- 7. Remote maintenance center
- 8. Management center
- 9. Mulhouse CETS

- Controller alarm--Switched ground telephone network
- CRT Ground-network connection equipment
- LAPS Logic for shared access to the satellite
- RF Radio-frequency equipment
- CR Reservation center
- CC Switching center
- CTI Data-processing center
- CPE Main operating center
- CETS Satellite-telematics operating center

The management center connected to the reference terminals is responsible for the allocation of digital links and issues inter-subscriber connection orders. Note, however, that no communication transits through Mulhouse: the links are made directly via the satellite, between stations located in the Telecom-1 coverage zone.

The center, which gathers traffic data, will soon be organized around three computers that will fulfill the various functions separately: switching (switching center), management and users' traffic (reservation center) and the processing of data concerning observations made on the network (data-processing center).

The remote maintenance center automatically centralizes in a computer any incident that may occur on the network. The stations set up as part of the Telecom-1 corporate network are equipped with a controller that monitors radio-frequency, TDMA and ground subnetwork equipment. If one of these devices fails, the controller warns the remote maintenance center of the incident via the switched ground network (for reasons of technical safety, the satellite link is sometimes interrupted on purpose). These controllers can also be consulted from Mulhouse and used to measure and test equipment operation.

#### A Polytechnic School

In addition to these activities, the Mulhouse CETS also has various other missions: videotransmission monitoring, operation of the regional traffic station, etc.

The Mulhouse team, consisting of about 60 technicians, must integrate all telecommunications technologies: switching, data processing, ground and satellite transmissions. It reflects the need for constant adaptation to technological change.

Telecom 1-B will soon arrive at the Kourou launch pad. In Mulhouse, everything will be ready to connect it to the network.

9294

CSO: 5500/2674

FRANCE

#### CIT-ALCATEL ENTERS U.S. LONG-DISTANCE MARKET

Paris ELECTRONIQUE ACTUALITES in French 29 Mar 85 pp 1, 12

[Article by D. Levy: "Supplying AT&T, GET and MCI, CIT-Alcatel Is Getting Established on the 'Long-Line' Market Niche in the U.S.A."]

[Excerpt] It was expected to be switching, but it is the transmission department of CIT-Alcatel that is about to achieve a nice breakthrough in the United States: orders received last year amounted to \$28.6 million, and projections for 1985 involve \$35 million.

This breakthrough is concentrated on the long-distance links of AT&T, GTE Sprint and MCI, the three carriers which practically cover all of this sector in the United States. CIT-Alcatel supplies the three companies respectively with 140 and 560-Mbit/s digital systems, "Celtic" concentrators and 12-channel analog systems.

In the next few years, the French manufacturer will attempt to consolidate its positions in the long-distance field--which is shifting to optical links--while eagerly awaiting the opening of a new promising market in the distribution sector.

The transmission department of CIT-Alcatel was remarkably efficient in seizing the opportunities that have appeared in the United States in the field of long-distance links. On this demanding but extremely attractive market, a company must above all be technologically credible and have the product "on the shelf." It must also be competitive. The French manufacturer was able to meet these conditions with the three carriers, which cover practically the whole "long-line" sector in the United States. It was also there at the right time to meet the U.S. demand. Which shows that a company must anticipate technology in order to have a chance to breakthrough in the United States.

Thus, when AT&T suddenly decided to digitize some of its (analog) coaxial cable links so it could offer a high-thruput data transmission service, CIT-Alcatel and Philips were about the only two companies able to solve the problem. The French won with its 565-Mbit/s system offering 8,000 circuits (at 64 Kbits) and an error rate of close to  $10^{-12}$ . And within 12 months, a record time, a first link between San Francisco and Oakland was equipped and placed in service early this year.

## Shift to Fiber Optics

Other orders were announced, so that this niche--although a marginal one on the U.S. telephone market--represents several thousands of kilometers of long-distance lines to be equipped with high-thruput digital systems. A windfall considering the miserable state of the French transmission market (which is nearly saturated).

The other side of the coin is that the U.S. market totally lacks visibility: the niche could be developed in 2 to 7 years, with orders of a magnitude that is impossible to predict. A difficult supply problem! After its existing installations have become profitable, AT&T will shift to optical links... Another challenge for CIT-Alcatel.

With MCI, CIT-Alcatel started a long cooperation since the early 1970's. Every year, or nearly every year, MCI would order a few million dollars' worth of 12-channel equipment from the French company. In 1984, the carrier accelerated its program, but it was (probably) its last order for analog hardware. Indeed, MCI is the first U.S. carrier to have committed itself fully to fiber optic transmissions. The firm is even a pioneer when it comes to single-mode links.

CIT-Alcatel acknowledged the end of analog-hardware orders, but it fully expects to continue its cooperation with MCI. Hence current negotiations on the sale of digital systems, the obstacle to be overcome being the traditional problem of delivery time: MCI wants deliveries in a few months...

Another carrier, GTE Sprint, has chosen the "Celtic 2G" concentrator of CIT-Alcatel to double the capacity of its links... on the condition that it will be delivered within 4 months! The French firm accepted the challenge and received equipment orders for 50 links.

The "Celtic" concentrator designed to double the capacity of analog circuits was developed by CIT-Alcatel to equip submarine cables. After a first-generation model, the firm developed the "Celtic 2G," which performs better (concentration of two 2-Mbit pulse trains into a single one, through 32-Kbit encoding), is miniaturized and, above all, less expensive than the previous model. This is the model that GTE selected... for its land links.

CIT-Alcatel is now tackling the market of fiber-optic links, not without some apprehension. A long-distance link in the United States is said to include 1,000 to 1,500 lasers... compared with 5 or 6 lasers in France where distances are shorter. Now, a 560-Mbit laser represents a cost of the order of FF 30,000!

9294

CSO: 5500/2667

FRANCE

BRIEFS

'SPOT' SUCCESSORS BY 1990--The French earth-observation satellites, Spot 1 and 2, to be launched respectively next November and in 1988 by "Ariane" will have two more advanced successors in 1990 and 1994, Spot 3 and 4, it was announced on 5 June at the Bourget Show by Mr Hubert Curien, Minister of Research and Technology. These Spot satellites built by MATRA-Space [Mechanics, Aviation and Traction Company/Space], each of which will cost close to FF 1 billion, represent a considerable progress: their ground resolution will be 10-20 m, depending on the colors used, whereas the U.S. "Landsat" satellites now in orbit cannot "see" details smaller than 60 m. In addition, the French satellites will be equipped with mirrors for lateral vision, which will increase the area covered, and stereoscopic shots. Also for the first time, a commercial company, Spot-Image, will sell throughout the world the images obtained by the Spot satellites orbiting at altitudes of 60 to 1,200 km. The photos will sell for around \$1,000 for a square area of 60-km side. "The two new satellites will have a longer lifetime (4 years instead of 2) and a new observation frequency, in the medium infrared," Mr Gerard Brachet, chief executive officer of Spot-Image, stated. "This innovation will improve the observation of crop zones and will lead to better geological interpretations," he added. [Text] [Paris AFP SCIENCES in French 6 Jun 85 p 33] 9294

CSO: 5500/2678

ICELAND

FREEDOM OF AIR WILL BRING RATINGS WAR

Reykjavik NEWS FROM ICELAND in English Jul 85 p 12

[Article by Einar Sigurdsson]

[Text]

**B**y passing new legislation abolishing the state monopoly on broadcasting, the Althing has opened up a new chapter in the history of Icelandic mass media which will undoubtedly affect political and politics as a whole. For one thing, no one actually knows where the new laws will lead to. After receiving a licence to operate, a new broadcasting institution has few restrictions imposed on it.

For more than half a century the state has maintained its broadcasting monopoly and run its services very much on the lines of public service and cultural enlightenment, political consensus and legally-enforced neutrality. The political will of parliament has been reflected in a powerful board of governors overseeing the output and in effect having the power of veto over programming personnel. This system of state broadcasting is maintained, but it will in future operate in fierce competition for resources with stations bound by none of the obligations that the state service has to observe.

**N**ew stations will not be forced to operate on a nationwide scale, which is scattered due to a mountainous country. They are not obliged to

go in for a costly domestic production, unlike the state service which is, as in the past, bound by law to cater for sections of the community that, in the foreseeable anything else, cannot be labelled anything war, but minority groups. A private broadcasting station is mostly free from political control such as that exercised by parliament in the affairs of the state service.

There seems little doubt that a fierce ratings war will result from the changing of the broadcasting laws. New stations will have access to the same income resources as the state service. Advertising revenue will be the most sensitive of these since commercial advertisers will undoubtedly turn to ratings leaders. Looking further ahead, low ratings would undoubtedly become a liability for the state service as far as the licence fee is concerned.

**P**roduction of domestic material is expensive — far more expensive than cheap foreign imports. Under the old monopoly system, the state run television service produced a smaller proportion of broadcast material than almost any other station in Western Europe. Faced with stiff competition from more cost-effective imports, domestic production seems bound to have to fight to keep up.

A number of radio stations are expected to crop up in the first period of private broadcasting. New television channels will be fewer, and indeed there must be limits to the service which can be maintained by a market the size of Iceland with its maximum of scarcely more than 200,000 viewers and listeners. A company owned by the publishers of Iceland's largest daily, Morgunbladid (which generally supports the conservative Independence Party), an influential publishing house, Reykjavik's municipal authority and the co-operative movement (Samband) is thought the likeliest founder of a new television station and such a venture is obviously in the cards.

**S**amband, which is financially by far the most impressive of these companies, seems, however, to be having second thoughts and might turn the

other way to a partnership with the labour union movement and the farmers' union. Whichever way the tide turns, Icelandic broadcasting is bound to change radically and could dramatically affect political debate and the formation of opinion.

The new broadcasting laws contain a fairness clause whereby those who feel that their views have been unsatisfactorily represented can appeal to the broadcasting authority which grants licences. Its findings will be binding for both parties to a dispute. This clause gives practically the only guidelines for the presentation of political material on the new stations and no doubt it will be tested soon. In addition there are of course accepted codes of journalistic behaviour set by half a century of legally-enforced neutrality on the state service. Such professional ideology is, however, much more vulnerable than the code of law.

CSØ: 5500/2675

ICELAND

PRIVATE BROADCASTING TO BEGIN NEXT YEAR

Reykjavik NEWS FROM ICELAND in English Jul 85 pp 1, 22

[Text]

In a historic vote, parliament has agreed to remove the monopoly on broadcasting which the State Broadcasting Service (SBS) has held since its foundation fifty-five years ago. New legislation on radio and television stations will take effect from January 1 next year, after which date a specially-appointed committee will begin issuing broadcasting permits for private concerns — many of which have already been formally established and registered with the authorities.

After lengthy and often heated debate, parliament has therefore finally passed the new broadcasting bill originally envisaged by Minister of Culture and Education Ragnhildur Helgadóttir (Independence Party) as becoming law at the end of last October, when the temporary shutdown at the SBS during the public employees' strike first brought the proposals to real prominence.

As an indication of its controversy in parliament as well as outside, the new law only received the support of a minority of MPs (29 out of 60); it was effectively carried through by abstentions. There was even speculation at one time that the centre-right coalition would split if opposition within some sections of the Progressive Party had jeopardized the passage of the bill, which had been assigned top priority by the Independence Party.

The new law reflects both the current swing towards privatization and the inevitability that

communications technology will soon open up possibilities beyond the control of a single national authority such as the SBS. In many ways it does little more than provide a broad framework for private broadcasting, by lifting the state monopoly, and its overall administrative effectiveness remains to be seen. It was on account of this lack of specific detail that the Social Democratic Party, which in principle supports private broadcasting, eventually opposed the bill and put a question mark against its survival for a while.

One of the most controversial clauses in the newly-accepted private broadcasting legislation concerns advertising revenues. All radio and television stations are to be authorized to finance their activities by advertising, whether

they broadcast over the air or simply operate cable networks on a subscription basis. Much uncertainty now surrounds the effect this will have on the finances of the SBS, which is still obliged to maintain its relatively costly national relay system and regional services.

Competition is already beginning to cause some concern at the SBS even before the new laws go into effect. It is rumoured that the SBS, recently suffering from shortages of technical staff who are lured to better-paying jobs with private video companies, faces a mass exodus when the rival stations go on the air.

Precise regulations still have to be set governing ownership of and access to cable networks. This subject, of particular importance with the foreseeable advent of satellite television, is expected to be dealt with specifically in a coming review of telecommunications legislation. There is also some doubt concerning standards to be adopted in preserving Icelandic from the cultural impact of foreign language programmes, on which point Minister of Culture and Education Helgadóttir intends to set a special regulation.

SWEDEN

SWEDISH-EEC JOINT RESEARCH AGREEMENT REACHED

PM201255 Stockholm DAGENS NYHETER in Swedish 12 Jun 85 p 12

[Bjorn Anders Olson reports: "Swedish-EEC Research Agreement"]

[Text] Sweden and the EEC have reached agreement on a joint framework agreement on research and development.

"We must make sure that the European states do not simply become satellites to those states which have taken the technological lead," said Willey de Clerq, EEC commissioner responsible for foreign policy questions.

Together with Swedish Foreign Trade Minister Mats Hellstrom he yesterday held the fifth so-called high-level meeting between Sweden and the EEC.

After the meeting they were both all smiles and outdid each other in stressing what fanatistically good relations Sweden and the EEC have.

Willy de Clerq said that the EEC is open for cooperation with Sweden and the other EFTA countries in practically every area, including agriculture.

At present the EEC and EFTA have a free trade agreement covering industrial products, but not agricultural produce and the major agricultural surplus in the 10 EEC nations is the Community's great headache.

When asked if he would like to see a free trade agreement for agricultural produce too between the EEC and EFTA, Willy de Clerq said with a tired smile, "We have to take realistic steps."

"First, we have to solve our own problems and those which will arise when the EEC is enlarged. We must devote our attention to smaller matters which can be carried out."

A little over a month ago, however, the EEC Commission put forward a proposal that trade between the EEC and EFTA in agricultural produce should also be made easier.

CSO: 5500/2681

END