

R

354054

JPRS 81946

7 October 1982

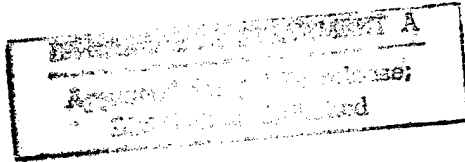

# Worldwide Report

TELECOMMUNICATIONS POLICY,  
RESEARCH AND DEVELOPMENT

No. 242

19980831 075

**FBIS**

FOREIGN BROADCAST INFORMATION SERVICE

5  
36  
AΦ3

#### NOTE

JPRS publications contain information primarily from foreign newspapers, periodicals and books, but also from news agency transmissions and broadcasts. Materials from foreign-language sources are translated; those from English-language sources are transcribed or reprinted, with the original phrasing and other characteristics retained.

Headlines, editorial reports, and material enclosed in brackets [ ] are supplied by JPRS. Processing indicators such as [Text] or [Excerpt] in the first line of each item, or following the last line of a brief, indicate how the original information was processed. Where no processing indicator is given, the information was summarized or extracted.

Unfamiliar names rendered phonetically or transliterated are enclosed in parentheses. Words or names preceded by a question mark and enclosed in parentheses were not clear in the original but have been supplied as appropriate in context. Other unattributed parenthetical notes within the body of an item originate with the source. Times within items are as given by source.

The contents of this publication in no way represent the policies, views or attitudes of the U.S. Government.

#### PROCUREMENT OF PUBLICATIONS

JPRS publications may be ordered from the National Technical Information Service, Springfield, Virginia 22161. In ordering, it is recommended that the JPRS number, title, date and author, if applicable, of publication be cited.

Current JPRS publications are announced in Government Reports Announcements issued semi-monthly by the National Technical Information Service, and are listed in the Monthly Catalog of U.S. Government Publications issued by the Superintendent of Documents, U.S. Government Printing Office, Washington, D.C. 20402.

Correspondence pertaining to matters other than procurement may be addressed to Joint Publications Research Service, 1000 North Glebe Road, Arlington, Virginia 22201.

JPRS 81946

7 October 1982

# Worldwide Report

TELECOMMUNICATIONS POLICY,  
RESEARCH AND DEVELOPMENT

No. 242



FOREIGN BROADCAST INFORMATION SERVICE

7 October 1982

WORLDWIDE REPORT  
TELECOMMUNICATIONS POLICY, RESEARCH AND DEVELOPMENT

No. 242

CONTENTS

ASIA

AUSTRALIA

Bidding Opened on Defense Communications Network (THE COURIER-MAIL, 10 Aug 82).....	1
Official Explains Rules for Private Media Use of Satellite (THE WEEKEND AUSTRALIAN, 14-15 Aug 82).....	3
Electronics Industry Independence Seen as High Priority (THE AUSTRALIAN, 16 Aug 82).....	4
Call for Indigenous Technology, by W. J. Caelli Microchip Project	
Controversy Over Plan To Relocate Sydney FM Antenna (THE AUSTRALIAN, 9 Aug 82).....	7
Government Agrees To Grant Supplementary Rural FM, TV Licenses (THE SYDNEY MORNING HERALD, 12 Aug 82).....	8
Briefs	
Satellite Design Changes	9
Worldwide Radio Link	9

PEOPLE'S REPUBLIC OF CHINA

Ground Station Receives Transmission From Intelsat (Gan Benfu, Hu Youquan; GUANGMING RIBAO, 22 Aug 82).....	10
Briefs	
Guangdong's County TV Station	12

LATIN AMERICA

BERMUDA

Cable, Wireless Wins Final Approval for Satellite Dish (THE ROYAL GAZETTE, 2 Sep 82).....	13
--	----

COSTA RICA

Briefs New Radio Stations	14
------------------------------	----

GRENADA

Briefs Expanded TV Coverage	15
--------------------------------	----

NEAR EAST AND NORTH AFRICA

EGYPT

Briefs New Telephone Circuits	16
Telecommunications Report	16

SAUDI ARABIA

Briefs Television Satellite	18
--------------------------------	----

SUB-SAHARAN AFRICA

NAMIBIA

Briefs FM Network Improvement	19
----------------------------------	----

ZAMBIA

Minister Denies Mass Media Complex Equipment Not Working (DAILY MAIL, 7, 6 Sep 82).....	20
Minister's Statement Statement of 'Reliable Sources'	

WEST EUROPE

DENMARK/GREENLAND

Nine Settlements To Get First Phone Exchanges  
(GRONLANDSPOSTEN, 11 Aug 82)..... 22

ITALY

New RF Hazard Monitor for Electromagnetic Fields  
(Marco Bini, et al.; ALTA FREQUENZA, Jul-Aug 82)..... 23

BIDDING OPENED ON DEFENSE COMMUNICATIONS NETWORK

Brisbane THE COURIER-MAIL in English 10 Aug 82 p 13

[Text] Canberra.--The Federal Government has re-started the lengthy process of calling tenders for a new \$200 million defence communications network, but it should be in use by the original 1990 target date.

The Defence Support Minister, Mr Viner, said six Australian and overseas companies, representing the world leaders in computerised communications technology, would be invited to submit tenders.

The former Defence Minister, Sir James Killen, announced last September that the tender for the Defence Integrated Secure Communications Network (DISCON) project would be reopened.

The first tender was abandoned after the company which won it, Collins International Service Company, informed the government last June that one sub-contractor involved in the tender had been changed.

CISCO is one of the companies invited to tender.

'Better System'

The Defence Communications System Division general manager, Mr Ian Maggs, said yesterday that the DISCON project would benefit from the delay.

"In modern communications, the world is moving fast, technology has moved with it and today we can be offered better systems. This is underlined by the fact that we now have six contractors for the network instead of the original four," he said.

"We also are more sure of what we want for DISCON and have reduced the project from six to two stages."

Stage one will cover the eastern half of Australia and the second stage will bring in the Australian Capital Territory and the western half.

DISCON will link major military bases and establishments throughout Australia and provide a national defence communications infrastructure capable of meeting defence operational needs to the year 2000.

The complete network should be in place before 1990, Mr Maggs said.

He said the new system could be based on the Ptarmigan network developed by Plessey for the British Defence Ministry.

It offered a secure digital communications system including voice, facsimile and data functions. DISCON also will include an upgraded secure telegraphic message system.

#### Tighten Security

The new digital system would improve security within the department's present communications system.

The government is aiming for an Australian industry participation target of 40 to 50 percent, providing a high level of involvement by Australian communication firms.

CSO: 5500/7565

OFFICIAL EXPLAINS RULES FOR PRIVATE MEDIA USE OF SATELLITE

Canberra THE WEEKEND AUSTRALIAN in English 14-15 Aug 82 p 5

[Text]

PRIVATE broadcasting organisations would not get domestic communications satellites for more than 20 years, the national conference of the Public Broadcasting Association of Australia was told yesterday.

A satellite would be shared by all broadcasting interests, including public and special interest groups, not just the powerful commercial telecasters.

This was to prevent commercial telecasters monopolising the satellite, and to spread the \$300 million cost of the satellite.

The first assistant secretary of the Department of Communication's broadcasting division, Mr Peter Westerway, told the seminar any public broadcaster wanting to use the satellite as a distribution vehicle would be forced to hire transponders at a cost estimated between \$1.5 million and \$2 million a year.

He said the late design change in Australia's satellite, approved by the Federal Government earlier this week, did not mean a reduction in the cost of transponders, nor did it mean the metropolitan television networks had a "definite ace" to draw.

The change was simply a "must improvement" to allow any broadcaster to

use a satellite for a national area rather than the four "footprints" of Queensland; NSW, Victoria and Tasmania; Western Australia; and the central beam to the Northern Territory and South Australia.

The change makes it possible to switch three of the footprints to national beams, but not four.

It would upgrade opportunities for metropolitan telecasters to use the satellite for direct broadcasting into areas covered by regional television stations, to introduce subscription television, and to distribute programs more cheaply to rural stations in a network.

But, Mr Westerway said, broadcasting regulations would approve none of these moves.

He said the changes could allow greater use of the satellite for data transfer and other non-broadcast uses.

The Government was expected to make a decision within the next six months about how the satellite HABCSS 2 could be used by television or radio.

Its decision would be based on a PBAA submission which has been in the hands of the Department of Communication since June.

ELECTRONICS INDUSTRY INDEPENDENCE SEEN AS HIGH PRIORITY

Call for Indigenous Technology

Canberra THE AUSTRALIAN in English 16 Aug 82 p 10

[Article by Dr W. J. Caelli]

[Text]

AUSTRALIANS have a fascinating attitude of technological and scientific idealism, and nowhere is this more prevalent than in discussions on information technology.

According to this thinking, an industry cannot be created unless it is a world beater or has clear competitive advantages on a world market.

An electronics and computer industry must be regarded as a fundamentally important industry in the 21st century for any developed country — so important that Australia must have a competent, though not necessarily world supreme or very large, industry.

The small business computer and the personal computer now cost less than the company or family car, but the non-existence of an Australian computer industry causes little concern, while any suggestion to abandon totally manufacture of cars could cause screams at every level of Australian politics.

The time has arrived where high-technology imports rival our imports of motor vehicles. The question is simple: can any small system be designed and manufactured in Australia and exported to the world market? The technical answer is a resounding yes.

Computer technology is now a basic industry. The concept

that Australia can continue totally dependent upon importation of systems is as unrealistic as endeavoring to make Australia completely independent in digital technology.

A middle road has to be found. The concept that we can now bid farewell to computer and information technology as a local enterprise and instead concentrate on some form of biotechnology, genetic engineering or the like, is totally unacceptable.

Advanced technology manufacturing has to be in Australia's future, and the question is how soon it will be in that light by the private sector, let alone by those in the public arena. Australia has to look beyond the glamor of the semiconductor industry to the information technology industry as a whole.

One great step forward is the establishment in this country of custom very large scale integration (advanced microchip) design laboratories, but the matter does not stop there.

The possibility is emerging that even though a VLSI chip is designed in Australia, it cannot be manufactured here and, even more important, may not even be able to be used here. The new chip technology

will place totally new demands on the electronics manufacturing industry to upgrade to make use of the new component in actual products.

The new chip systems are useless unless they can be mounted

on a printed circuit board or equivalent and interconnected easily and effectively with both like and unlike components — and here an old enemy has once again emerged.

This is the problem of heat. The dense VLSI components are absorbing more and more electrical current that is dissipated as heat that must be removed from the chip itself, resulting in development of new microchip designs.

**Shrunk**

While the chips do more in less space now, the whole information or computer system can also be shrunk and the high-performance cigarette-pack computer is around the corner.

By 1988 a good 50 per cent of electronics production will have moved to some form of chip-carrier technology or like method of getting the VLSI chips and other components to work together on a printed circuit board.

The reasons are obvious. The little square VLSI pills can be almost butted together with saving in space, lowering of manufacturing costs and improvements in speed.

This has tremendous importance for Australian electronics manufacturing. Already Australia is limited in multi-layer printed circuit board facilities.

Without recognition of what is happening not just at the

more glamorous microchip component level, but at the high-technology manufacturing process level, the benefits of new VLSI technology may totally bypass Australia, once again.

Without back-up manufacturing capability, any idea of a wafer plant in Australia for VLSI would be pointless.

One section of information technology cannot be selected in isolation and developed to the exclusion of all others.

Similarly, at tertiary levels, actual computer design and research and the areas of computer architecture seem to be remote from Australia.

The number of groups involved in development of innovative structures via use of bit-slice-components and micro-coding seems to be very small.

An indication of this problem can be seen in the small number of papers to be presented at the 9th Australian Computer Conference in Hobart late this month related to computer hardware and systems software.

Some outstanding work is being done in computer science, such as the Monads software system from Monash University, the Pascal validation suite from the University of Tasmania, or software engineering at the University of Melbourne.

But actual hardware and system research seems to have moved away from departments of computer science in Australia, at a time when it is most needed.

No matter which way we look at it, the products of Australia's schools of computer science, electronic engineering and like disciplines are faced with either working in the application of the fundamental technologies or leaving Australia to work overseas

with various high-technology groups.

### Domestic

The aim of an indigenous information technology industry must be to stop this.

The Premier of NSW, Mr Wran, recently called for a "Buy Australian" act — this much discussed concept has been put forward by Australia's own computer companies for many years but at the Federal Government level incentives to buy Australian have actually decreased to a point where words such as "may give preference" have become the norm.

The size of a contract for any preference to apply must be large (around \$100,000 or more) — as against the overseas situation where not only purchase but research-development and other techniques have long been used to promote indigenous high-technology industry.

Even at State level, preferences for local products in State tendering appear to be rooted in earlier decentralisation policies, with upper ceilings of such incentives around a deplorably low 15 per cent.

To get such low-level preference a manufacturer would have to have an all-Australian made product (all components) and be manufacturing away from major centres.

The levels of State preference must be regarded as almost totally pointless in information technology, being less than the current interest rate offered on Government-secured loans.

Mr Wran's proposal for a 30 per cent offset in NSW for overseas companies tendering to his State must be contrasted with the appallingly low preference NSW offers Australian manufacturers, particularly those outside NSW.

The situation is similar in Victoria, where preference is on a State basis.

A consistent, Australian-oriented policy is needed that is a uniform for all States.

The focus of recent discussion in Australia has been based upon the microchip, its design and manufacture.

But this is where the discussion stopped: rather like like talking about a carburettor industry for Australia.

The microchip is a component. A clear separation has to be made between a component industry and a computer-communications industry.

The former produces parts — more and more sophisticated parts, for the latter. The latter produces a useful product for an end-user but in-between also comes areas of systems and applications software and nowadays, the communications links.

Moreover, the job-generation patterns of each section of the industry are different, from highly trained research personnel in microchip design to technically trained production test engineers for computer systems to on-the-job trained people for assembly and test of completed printed circuit boards.

The 1950s and the post-War baby boom saw Australian tertiary education develop at a fast rate, leading to the brain-drain days of the 1960s.

After 30 years of advanced education in Australia, it must surely be seen as an indictment of our sense of national pride to have to set up incentives for overseas advanced technology companies to come to Australia.

There is no doubt Australians can, and do, manufacture computer systems and create systems software and communications products in the small to medium range.

## Microchip Project

Canberra THE AUSTRALIAN in English 16 Aug 82 p 11

[Text]

AUSTRALIA's prospects for independence in the vital field of micro-electronics technology is critically dependent on an ambitious project being mounted by the CSIRO Division of Computing Science.

The division, in Adelaide, is home to Australia's world-leading Very Large Scale Integration (VLSI) microchip development centre, run by Dr Craig Mudge, and has already been the scene of dramatic successes since its inception last year.

### Applications

The aim of the scheme is to design and manufacture microchips in batches, with devices tailored to several different applications being produced in each batch.

The technology and the design concepts used in this "multi-project chip" venture is at the leading edge of contemporary science. Only last May, an international micro-electronics conference was held in Adelaide, and provided a vital stimulus for the scheme.

Many of the world's most famous pioneers of VLSI chip design, including Professor Carver Mead of the California Institute of Technology, and British and European experts, attended, and their presence effectively put the CSIRO project on the map as an international-class development.

Using VLSI design techniques, Australian engineers develop the intricate architectures for their specific microchips, before the devices are actually made.

The commonality of basic design gives the CSIRO scheme a tremendous economic advantage, but the

most important aspect of the effort is that the technology is being introduced and developed here even as it is being pioneered in the rest of the world.

The foreign experts who attended the Adelaide conference were agreed that Dr Mudge's project has sown the seeds for a viable, internationally competitive Australian VLSI industry.

From a strategic point of view, it is essential that the fine microchips produced by the latest technologies should be available here, so the nation is not dependent on exports.

### Competition

In addition, the use of tailor-made microchips in manufacturing will provide a much-needed tonic for local companies as they are gradually deprived of their long-standing tariff and trade protection barriers against foreign competition.

A statement by the Minister for Science and Technology, Mr Thomson, is expected at the end of this month on the future development of the project, and work is due to begin soon on the second batch of multiple project VLSI chips.

CSO: 5500/7566

CONTROVERSY OVER PLAN TO RELOCATE SYDNEY FM ANTENNA

Canberra THE AUSTRALIAN in English 9 Aug 82 p 1

[Text]

THE Federal Government is likely to remove the ABC's frequency modulated transmission antenna from the Sydney transmission tower in an effort to solve Channel 0-28's transmission difficulties.

The Government's plan — fiercely criticised last night by an FM radio station — would involve building a \$660,000 transmission tower to house all FM transmissions in the metropolitan area.

The \$25 million a year, multi-cultural 0-28 channel has been dogged by poor transmission in Sydney since it began operations in Melbourne and Sydney in October 1980.

The problems are said to cut 0-28's potential viewing audience by half, depending on weather conditions, and have kept down its ratings.

Much of the problem is because its broadcasting antenna is at a height of only 48.7m on the ABC's Sydney tower, with the tower not strong enough for the antenna to be elevated.

But, the Department of Communications has now calculated that the 0-28 antenna could be lifted to 122m if the ABC's FM transmission facility is removed from the tower.

The proposed new 45.7m FM

tower, eventually to house all Sydney's FM stations, would be at Northpoint in North Sydney. The site is presently utilised by 2CBA-FM, using a smaller tower.

The Government was previously considering locating the FM antennae on the highest building in the Southern Hemisphere, the Centrepoint Tower in the heart of Sydney.

Its change of heart was severely criticised last night by spokesmen for 2MBS-FM, who warned that the Government faced "a towering headache" if it went ahead with the Northpoint scheme.

Its technical adviser, Mr Grahame Wilson, said the proposal was "expedient and makeshift" and, for the sake of spending an extra \$200,000, Centrepoint was a much better site.

The station presently transmits from the AMP building at Circular Quay.

A spokesman for the Minister for Communications, Mr Brown, said last night there were persuasive arguments in favor of the North Sydney location.

The spokesman said there was no reason for 2MBS-FM to move from the AMP building if it didn't want to and, in

any case, some 140 other communications services were using Centrepoint and they would all be affected by location of the FM antennae there.

The spokesman said the Department of Transport was also extremely concerned that air navigation aids operated on parallel frequencies next to the FM frequencies, and the flight-path on the approach to Sydney was at about the same level as the Centrepoint transmission points. This meant "a real possibility" of interference.

The spokesman said there was also likely to be stern opposition from the major metropolitan television networks if Centrepoint were chosen. This was because there would be more interference to television signals than would be the case at Northpoint.

Mr Brown's spokesman said other FM stations, including the ABC's 2JJJ, were happy to move to Northpoint.

In a table of comparative costs the Department of Communications has calculated the capital cost of the North Sydney project at \$660,000, compared to \$805,000 for Centrepoint.

CSO: 5500/7565

GOVERNMENT AGREES TO GRANT SUPPLEMENTARY RURAL FM, TV LICENSES

Sydney THE SYDNEY MORNING HERALD in English 12 Aug 82 p 2

[Text]

Roughly three-quarters of the four million viewers in rural areas throughout Australia will get a wider choice of channels as a result of a decision by the Federal Government yesterday to grant supplementary licences to country broadcasters.

The move will also bring FM radio to country areas.

Details were announced yesterday by the Minister for Communications, Mr Brown. The broadcasting tribunal is to be allowed to grant one supplementary licence to each existing radio or television licensee in centres other than the five mainland State capitals.

The Communications Department estimates that the scheme would be open to 99 radio and 36 television stations; it expects that perhaps 50 radio and 25 television stations will take it up.

Mr Brown said the purpose was to give a wider choice of programs to people who lived in places too small to support another independent commercial station. Places like this at present were restricted to one commercial and one ABC station.

The new scheme will allow existing operators to broadcast on one extra channel or radio frequency. VHF frequencies, compatible with existing ones, are to be used where ever possible.

The department is to arrange the new frequencies during the next few months, and it is thought the first of the new stations might be on the air by the end of next year.

The scheme is expected to create jobs: new transmitters and possibly new studios will have to be built, and extra staff needed to man them.

Among major areas to benefit will be Canberra, Hobart, Newcastle and Darwin.

In Canberra, the existing commercial licence-holder, Australian Capital Television (CTS 7) will be able to transmit on one other channel and could, if it wished, take a complete service from one of Sydney's three commercial stations.

Mr Bill Rayner, chief executive of CTS 7, said a new licence administered by his station would give Canberra a choice of four channels by the end of next year. [The Government announced last month that Canberra would next year be first in a series of cities to join Melbourne and Sydney in receiving multicultural Channel 028].

CSO: 5500/7565

## BRIEFS

**SATELLITE DESIGN CHANGES**--The Federal Government has approved design changes to Australia's proposed domestic satellites to give the new system greater flexibility. The Federal Minister for Communications, Mr Brown, said in Perth yesterday that the changes would enable users of the satellites' high-powered 30-watt transponders to switch between State and national beams. WA television stations, for example, would be able to switch from the WA spot beam to the national beam to broadcasts of national interest. Users of the national beam would be able to switch to individual spot beams for news items of interest to particular States. In the original design, users of the high-powered transponders were to be locked into one or other of the satellites' four spot beams. [Text] [Perth THE WEST AUSTRALIAN in English 13 Aug 82 p 8]

**WORLDWIDE RADIO LINK**--The Omega navigational facility near Melbourne is now operating as part of a world-wide radio link-up. The Minister for Aviation, Mr Fife, and the Minister for Transport and Construction, Mr Hunt, announced the start of operations yesterday. Mr Hunt said the station was the last link in the network of eight Omega stations. "Omega is the only global continuously available radio navigation system," he said. "Although the overall system has been in operation for over 10 years, using available stations to provide navigation for aircraft and ships, the coverage of the system in the Australian area had limitations." [Text] [Canberra THE AUSTRALIAN in English 17 Aug 82 p 1]

CSO: 5500/7566

GROUND STATION RECEIVES TRANSMISSION FROM INTELSAT

Beijing GUANGMING RIBAO in Chinese 22 Aug 82 p 1

[Article by Gan Benfu [3927 2609 4369] and Hu Youquan [5170 2589 3123]:  
"Chinese Designed Ground Station Receives First Intelsat Transmission"]

[Text] Using the Intelsat situated 36,000 kilometers above the Indian Ocean, the Nanjing satellite communication station conducted television transmission tests in the afternoon of 18 August. Leading comrades of the Ministry of Electronics Industry, Jiangsu Province, Nanjing Municipality, and other units involved were present at the site to view the television programs transmitted by Intelsat. Ground stations in Shanghai and Shijiazhuang also carried out reception simultaneously. The transmission tests were a success; the television pictures transmitted were sharp and the accompanying sound track was loud and clear.

The following stations of the Ministry of Electronics Industry have participated in the tests: The Nanjing 10 meter (antenna diameter) test station, Shijiazhuang 15 meter and 5 meter test stations, Nanjing 5 meter and 3.2 meter television receiving stations and Shijiazhuang 5 meter television receiving station. All the equipment in the Nanjing and Shijiazhuang ground stations were designed by the Chinese and built using Chinese-made components and material. This test had the full support of the telecommunication, meteorology, measurement, and news departments.

From April 1978 to February 1979, the Nanjing and the Shijiazhuang satellite communication ground stations have made use of the "Symphony" communication satellite jointly developed by France and West Germany to transmit television, newspaper, multichannel telephone conversation, time and frequency standard and live television broadcast of Comrade Fang Yi [2455 3015] visit to West Germany and France. The results were successful.

In the two major tests of communication satellite transmission, Chinese-made satellite communication ground stations were proven to be totally capable of transmitting television, telephone, image and data using the Intelsat. It reflected the new level the Chinese electronics industry has entered in terms of material, components, equipment development and ground station construction. It has also demonstrated that China has cultivated a ground station construction and research team consisting of mainly middle-aged and young technical personnel and has laid a sound foundation for its future work in satellite communication, broadcasting, image transmission and television.

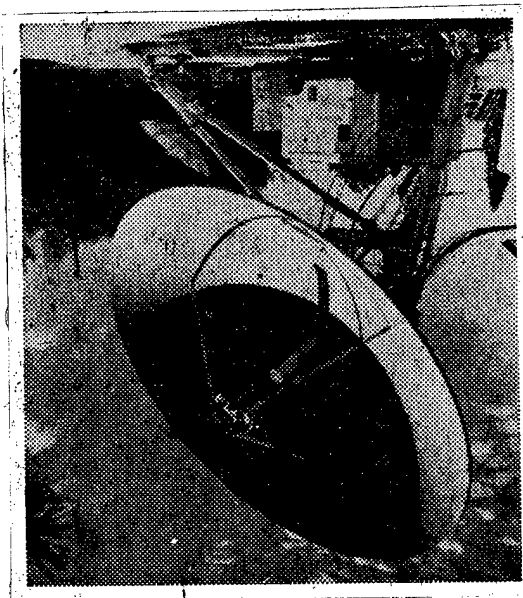

10 meter diameter antenna of the Nanjing satellite communication station

9698

CSO: 5500/4024

BRIEFS

GUANGDONG'S COUNTY TV STATION--Kaiping County in Guangdong Province has built a new TV relay station. As a result, the eight communes within a radius of 10 km from the county seat can receive the programs of the Central and Guangdong Provincial TV stations even better. [Text] [HK161455 Guangzhou GUANGDONG Provincial Service in Mandarin 1000 GMT 16 Sep 82]

CSO: 5500/4027

## CABLE, WIRELESS WINS FINAL APPROVAL FOR SATELLITE DISH

Hamilton THE ROYAL GAZETTE in English 2 Sep 82 pp 1, 13

[Text]

Cable and Wireless has won the final round in its battle to erect a satellite dish more than 100 feet high on the north shore ridgeline in Devonshire.

The Development Applications Board has given the telecommunications company final approval to go ahead with its \$18 million scheme which was the centre of controversy last January when it drew harsh criticism from the Bermuda National Trust.

On the one hand, the "Satellite A" dish will give a tremendous boost to the number of long-distance calls which can be handled from Bermuda at any given time; replace undersea cables which will have reached the end of their life-spans by 1985 and which would cost some \$44 million to replace; and will mean that telephone calls to points throughout the world can be placed direct without being routed through North America.

Cable and Wireless chiefs also hope the facility will be used to transmit television coverage from overseas of major sporting events.

But on the other hand, the dish — planted on a 15-foot pedestal building along the north shore at the company's Devonshire plant —

clearly contravenes the 1974 Development Plan which protects the environment and Bermuda's ridgelines. The giant facility — measuring some 97 feet in diameter and on its pedestal towering more than 100-feet into the sky — will be clearly visible from its vantage point through to St. Brendan's Hospital, Kilderry Estates and North Shore Road.

While some planting around the dish has been planned, Cable and Wireless engineering manager Mr. John Fuge said in May that trees would absorb signals the dish should receive.

Engineering manager of transmission Mr. John Driscoll said yesterday that original plans to put up a power house to increase the company's generating capacity by Christmas had now been put back because of the length of time it has taken the company to receive final planning permission for the dish.

Instead, he said, the company will forge ahead with the construction of the earth station building. Preliminary site clearance is scheduled to begin on September 20.

Construction of the actual receiving station is targeted to begin next June or July.

Mr. Driscoll said yesterday that the main purpose of the new dish was to guarantee good international telephone service. "The design life of our submarine cables to the United States expires in 1985, so we require to have the dish working by that date in order to provide good telephone service."

The cables have already reached saturation point — many calls placed to the United States are now being routed through Canada and the Caribbean. And it is impossible for Bermuda calls to other parts of the world to be placed direct — they first go through the United States or Canada.

Plans announced in July to construct a viewing area so that Bermudians can watch the dish being constructed without going onto the construction site have already been approved by the D.A.B.

It is thought that it will be turned into a small parking area when construction is completed.

While the dish has a working life of about 25 years, Mr. Driscoll said yesterday that new technological developments could force the company to replace it before then. He said that Cable and Wireless would use it for at least ten years, however.

## BRIEFS

NEW RADIO STATIONS--The Costa Rican Government has decided to neutralize Nicaragua's "ideological radio waves." Beginning in October, Costa Rica will install a powerful cultural radio station in Upala, located near the border with Costa Rica's neighbor, according to reports from the Presidential Office. Residents of the northern part of the country constantly complain that only Nicaraguan radio stations can be heard there. The new radio station will transmit 24 hours a day, and there will be special cultural programs for the area with a simple set of messages. Another radio station will be set up in Pital, San Carlos, and another in Nicoya. The Princess of Liechtenstein, who will arrive here next month, will take part in the inaugural ceremonies, as her principality in Europe is a partial sponsor of the new radio stations. The station at Nicoya will open next 2 October, and Vice President Armando Araúz, a native of that city, is expected to attend the ceremony. The transmitting power of our nation's television stations may be boosted in the future in order to neutralize the influence of the Sandinist network, which penetrates deep into the northern region for 6 hours every day. [Text]  
[San José LA REPUBLICA in Spanish 25 Aug 82 p 2] 9839

CSO: 3010/2302

## BRIEFS

EXPANDED TV COVERAGE--Television Free Grenada (TFG) has gone nightly until August 17 and has now established simultaneous coverage to the parishes of St. Andrew's, St. Patrick's and surrounding areas, with St. George's. The coverage is expected to cover the current netball competition, and the upcoming Carnival celebrations. The simultaneous coverage is due to the creative work of TFG's staff and attempts are being made to extend the service to the parishes of St. Mark's and St. John's in the near future. A source at TFG, however, has stated that the problems of poor-quality reception experienced by viewers, particularly in the St. George's area, are not insurmountable. Unavailability of spare parts has been the main cause but attempts are being made to rectify this problem, the source said. [Text] [St Georges FREE WEST INDIAN in English 4 Aug 82 p 3]

CSO: 5500/7567

## BRIEFS

NEW TELEPHONE CIRCUITS--Engineer Sulayman Mitawalli, Minister of Transportation, Communications and Maritime Transport, has issued instructions to Engineer Ahmad Kamil, chief of the communications board, to implement the decisions of the committee of integration between Egypt and Sudan in the area of communications. Engineer Ahmad Kamil, chief of the Telephone Board, has explained to AL-AKHBAR that in implementing the instructions of the minister, a technical delegation from the communications board was sent to Khartoum, and carried out repairs on the earth satellite station in the area of Umm Harraz, as well as the earth station in Wadi Halfa and the wave propagation station in Wadi Halfa. The number of new direct circuits between Cairo and Khartoum is now six, in addition to three others through INTELSAT and the 46 telephone and telex circuits currently operating between the two countries. The chief of the board said that 12 other new telephone circuits through Saudi Arabia have been successfully tested and will be placed in service very shortly. These circuits will be used by all jurisdictions, banks, media and economic institutions. [Text] [Cairo AL-AKHBAR in Arabic 25 Aug 82 p 6] 7005

TELECOMMUNICATIONS REPORT--The National Council for Production and Economic Affairs, chaired by Dr 'Abd al-Qadir Hatim, the general supervisor of specialized national councils, has completed preparing an important report concerning the general strategy for telecommunications. This report will be submitted to the Committee on Transportation and Communications of the National Democratic Party for discussion and will be referred to the Third general conference of the party for debate on 20 September. The report emphasizes the need to exempt the Egyptian Company for the Manufacture of Telephone Equipment and the Cable Company from custom duties on production requirements, along with imposing production taxes on what is sold to other firms. Moreover, the obtaining of loans and credit facilities by local firms from Egyptian banks on acceptable terms must be facilitated. There should be agreement with the banking system to finance the sales of the cable and telephone equipment companies, on the basis of cash payment to the firm, so that they can be competitive with foreign firms operating in this field. The report stressed the need to continue developing the domestic firms' production and for the commitment of the Telephone Commission to use this production in the coming years, provided that the system to be manufactured locally is chosen in light of the electronic system, whose efficiency was proven after installation and operation of the European group's centrals, as well as those

of the American company. Moreover, there must be technical training in the field of telephonics, continued support for domestic industrialization of telephone cables and complete dependence on the production of the telephone equipment company, in the first place, and the giving of priority to domestic supplies. [Text] [Cairo AL-AKHBAR in Arabic 21, 25 Aug 82 p 6] 7005

CSO: 5500/5015

## BRIEFS

TELEVISION SATELLITE--Jidda, 18 Sep--Initial studies for the Saudi television space satellite, which will telecast the kingdom's programmes throughout the country and neighbouring states, are now complete, Saudi Information Minister Dr Muhammad 'Abduh Yamani said here today. He said the satellite, to be produced by France, would also provide the Information Ministry with telegraphic services. Dr Yamani added that the ministry had established 62 centres for the transmission of television programmes, including major transmission and production centres at Riyadh, Jidda, Al-Dammam, Qasim al-Madinah and Abha. Dr Yamani said the Saudi television project included two satellites--one would be in service and the other on standby to replace the first in case of disorder. He added that the project also included a ground station for transmission, control and communications, in addition to three reception and transmission stations for the kingdom's three main regions. [Text] [LD190440 Riyadh SPA in English 1941 GMT 18 Sep 82]

CSO: 5500/4738

BRIEFS

FM NETWORK IMPROVEMENT--The FM network of the SWABC is to be expanded in the south of the country. This was announced by Mr P. J. Venter, Chairman of the SWABC Board at the weekend. The expansion of the FM network has been made possible by R7.5 million allocated by the Department of Finance to the SWABC. The money will be used to expand FM network in the south of the country, to improve radio reception and to establish the necessary studio facilities. Mr Venter stressed that the broader aim was to render a service to the entire community and to improve broadcasting services as a whole. [Text] [Windhoek THE WINDHOEK ADVERTISER in English 13 Sep 82 p 3]

CSO: 5500/1

## MINISTER DENIES MASS MEDIA COMPLEX EQUIPMENT NOT WORKING

## Minister's Statement

Lusaka DAILY MAIL in English 7 Sep 82 p 5

[Excerpts]

**MINISTRY** of Information and Broadcasting Services permanent secretary Mr Edward Lubinda has dismissed reports that about K2 million worth of new equipment at the mass media complex is either already out of work or not working properly.

Mr Lubinda, who yesterday conferred with both Zambia Broadcasting Services and Zambia Information Services heads said both had assured him that all the machines were in working order.

He said consultants at the mass media complex had also confirmed that all the machines were working properly.

Mr Lubinda noted that both technical and production staff at the Zambia Broadcasting Services had not yet moved to the new mass media complex adding that how then could they damage equipment at the complex before they even move there.

Mr Lubinda said he did not know where the origi-

nator of the story got his facts from.

A report in this paper quoting reliable sources named machines that are out of order as a video news film processing machine whose cost is estimated at K1 million and the Eastman colour negative processing machine valued at about K426,000.

Those that are said not to be in good working condition include the optical printer worth about K1 million.

Meanwhile, Television Zambia (TVZ) was off the air on Sunday night as a result of a fault on the antenna.

Zambia Broadcasting Services (ZBS) director-general Mr Alport Phiri said yesterday that there was a fault on a piece of equipment on top of the antenna, which resulted in a blackout on television.

Mr Phiri said engineers rectified the fault yesterday and transmission resumed.

[Text]

**ABOUT K2 million worth of new equipment at the Mass Media Complex in Lusaka is either already out of order or is not working properly, reliable sources confirmed yesterday.**

This revelation comes barely one month after the Zambia Information Services (ZIS) and Zambia Broadcasting Services (ZBS) moved their offices to the complex.

The machines which are out of order include a video news film processing machine estimated to cost K1 million and the Eastman colour negative processing machine worth about K426,000.

The Optical Printer, worth about K1 million, is unable to analyse colour films properly because those who bought the equipment forgot to buy an analyser costing about K423,000.

"At the moment, to get a good colour film from the Optical Printer is completely guess work since there is no analyser. The machine only gives out green or yellow film reels," the source said.

He attributed the damage caused to the video news film processing machine and the Eastman colour negative processing machine to lack of proper training given to the technicians.

He said the technicians handling the machines only attended a four-day orientation course conducted by Japanese experts four months before offices moved to the complex.

"To expect such technicians to understand fully the operations of such complex machines after only a few days' course is expecting too much from them. The solution, before more damage is done, is to send people for more specialised training," the source said.

Contacted for comment yesterday, Permanent Secretary for Information and Broadcasting Services, Mr Edward Lubinda, said he was

not aware that some machines had stopped functioning at the complex.

"What you are telling me is news to me. I will get in touch with the director of Zambia Information Services and get details," he said.

In July, Permanent Secretary for Personnel Division, Mr Mwiche Siwale, was told during his tour of the complex that some ZBS office orderlies had been deployed in technical jobs because of the shortage of trained staff.

He was told by ZBS staff and Mr Lubinda that unless the Government took immediate steps to beat the staff crisis the complex would be a white elephant.

ZBS chief engineer, Mr Churchill Mutale said the organisation was not gaining from the contract with the Japanese in that there was an allowance of a 12-month guarantee in which to train staff to man the complex.

According to Mr Mutale, the complex would require about 200 technical men of which half would be engineers and the other half operators. ZBS has 10 qualified engineers at present and these are scattered around the country.

Last year, Minister of Information and Broadcasting Services, Mr Mark Tambatamba said Zambia was unable to train enough radio and television engineers, photographers and cameramen because of lack of funds.

He said, however, everything was being done to share equally the little resources available.

NINE SETTLEMENTS TO GET FIRST PHONE EXCHANGES

Godthaab GRONLANDSPOSTEN in Danish 11 Aug 82 p 20

[Text] The isolation of nine rural settlements will be greatly reduced within a year when private homes get telephone service. The work of laying cables and establishing telephone exchanges is well underway in several areas at this time.

The nine settlements in question are: Kangersuatsiaq, south of Upernavik; Sattut near Ummannaq; Attu and Miaqornaarsuk in Kangaatsiaq county; Sarfannguaq, east of Sisimiut; Narsaq Kujalleq and Aappilattoq near Nanortalik and Kuummiut and Kulusuk in Tasiilaq country.

These settlements were chosen in cooperation with the government. There are plans to modernize the telephone service in other settlements at a later time, but no selection has yet been made.

"When the work is completed, it will no longer be necessary to go through the local government exchange to complete a call. The service will be just like that in the cities today," said the regional telephone director Erik Villumsen, Nuuk.

Actually, the work should have been completed this year, but due to a number of unforeseen difficulties the work has been delayed. Erik Villumsen cited the telephone strike last year, which occurred just at a time when cables could have been laid.

"This delay affected our plans well into 1983," said the regional director.

Two other settlements will also get improved telephone service within the foreseeable future; they are Ivittut in South Greenland and Kitsissuarsuit, located between Qeqertarsuaq and Aasiaat, where up to eight telephones will be put into service.

By establishing a telephone exchange in Attu, it will be possible to call Ikerasaarusuk, a settlement of about 50 people. Regional telephone director Jorgen Gant, Aasiaat, referred to this settlement as "the telephone system's bad conscience." They have no telephone service at all because there is no government representative there. Normally, the government trade agent has a telephone, but there is no agent, office or store in Ikerasaarsuk.

## NEW RF HAZARD MONITOR FOR ELECTROMAGNETIC FIELDS

Milan ALTA FREQUENZA in English Jul-Aug 82 pp 233-236

[Article by Marco Bini, Amleto Ignesti, Luigi Millanta, Nicola Rubino and Riccardo Vanni, Istituto di Ricerca Sulle Onde Elettromagnetiche del C.N.R.: "An RF Hazard Monitor"]

[Text]

*Abstract.* The instrument illustrated in this paper has been designed and built to monitor RF electromagnetic fields with respect to safety standards. It is low-cost, easy to use and its indications can be immediately understood even by untrained personnel. Its particular characteristics make the instrument especially suited to monitor the fields in proximity of RF heating machines where the largest number of potentially hazardous situations for the operator are present.

## INTRODUCTION

The problem of Non Ionizing Radiation hazards looks complex if faced in terms of environment pollution and if proper distinctions between various exposure conditions are not made.

A comparative analysis of the various types of RF field sources [1] allows a rational evaluation of the various exposure conditions and suggests measurement and protection methods suitable for any particular situation. Electromagnetic energy finds more and more use in civil, military, industrial and medical applications (telecommunication, broadcasting, radiolocalization, RF heating, diathermy, etc.). It has been seen that the last two present the most complex and potentially hazardous situations. Furthermore they are the source of the largest number of survey and control missions.

In this paper we describe a RF Hazard Monitor, patented by the authors [2], which has been designed and built considering the particular complexity of fields produced by RF heating machines. Of course it is also suited to monitor RF field from different sources and situations in the same frequency range. The design objectives were: low cost, ease of use, immediate relation of the reading to safety standards. All these requirements are basic to allow for widespread availability (possibly one for each potentially hazardous RF source), without the need of specialized personnel. The field level

can be thus monitored at any time, without resorting to highly qualified groups, identifying the zones where exposure should be forbidden or limited and those where unlimited exposure is permissible. Moreover the direct identification by working people of the hazardous and safe zones can eliminate all the concerns and anxiety rising from the impossibility to sense this polluting agent.

The instrument can also be a useful tool during tentative operations of grounding and shielding aimed at reducing hazardous leakage levels. These can occur, for example, after modifications or maintenance operations of the apparatuses.

A brief review of RF heating machines will help to understand the characteristics and use of the instrument. The frequencies range between 1 and 100 MHz [3],[4],[5], with a marked majority within  $10 \pm 20$  MHz for wood industry and within 30 MHz for plastic sealers. Typical powers are of the order of tens (sometimes hundreds) of kilowatt. The fields to be measured are essentially reactive near fields, and in the majority of cases are electric fields, even in the presence of coil applicators for which, according to our experience [1], the field impedance is comparable to or higher than  $377 \Omega$ . The fields decay rapidly with distance from the applicator edges, roughly as  $d^{-k}$ , with  $k = 2$  to 3. The field distribution can be complicated by the presence of metallic objects; significant fields can be "conducted" across the room by leakage currents and unwanted couplings to metallic wires and pipes. These fields too decay rapidly away from the supporting structure. Fig. 1 shows the distances  $d$  from the applicator edge at which the USA and USSR safe levels are reached, for two different values of  $k$ , as function of the field intensity  $E_0$  at  $d_0 = 15$  cm.

The operation frequency and the field distribution can vary with load conditions, aging and modification of the apparatus.

In conclusion: a) the fields to be monitored are essentially confined to "hot spots"; b) the field configuration may vary in time in unpredictable manner. The consequence of this is that frequent monitoring of the field level is more significant than occasional high accuracy measurement. This can be accomplished by a low-cost, easy-to-use field monitor, which can be operated by the working personnel.

#### DESCRIPTION OF THE INSTRUMENT

The RF Hazard Monitor meets the stated requirements. It is essentially composed of a) a field probe; b) a comparator circuit with preset voltages (according to safety standards previously agreed upon) c) a simplified display. It is small, light, portable and battery operated (Fig. 2).

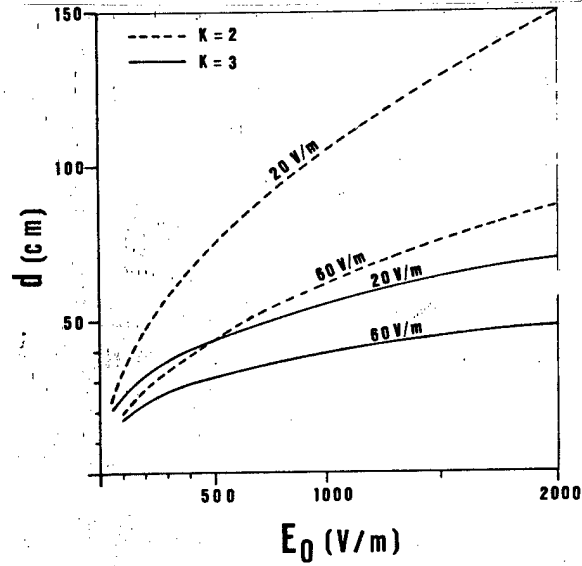

Fig. 1 - Distances at which USA (60 V/m) and USSR (20 V/m) safe levels are reached as a function of the field  $E_0$  at 15 cm. Spatial variation  $1/d^k$  of the electric field is assumed. Dashed line:  $k = 2$ ; solid line:  $k = 3$ .

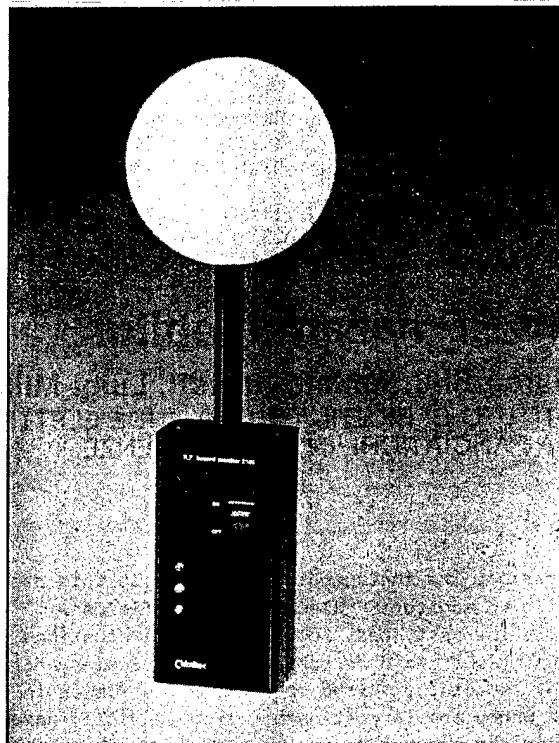

Fig. 2 - Laboratory prototype of the RF Hazard Monitor.

The field probe is isotropic. Isotropy is an essential feature for this type of instrument. Although the e.m. energy absorption depends on the field polarization relative to body position, reference polarization is not present in any safety standard because that would introduce unnecessary and detrimental complication in the measurement of field levels.

Isotropy is achieved by connecting in series three mutually orthogonal short dipole antennas. Each dipole is directly connected to a crystal detector, a flattening capacitor and a filter (Fig. 3). The crystals act as square law detectors within the field range of interest (indication of "hazard"). Each detector thus gives a voltage proportional to the square of the electric field in the direction of the corresponding dipole, and the sum of the three is proportional to the square of the total electric field.

A flattening capacitor is connected in parallel

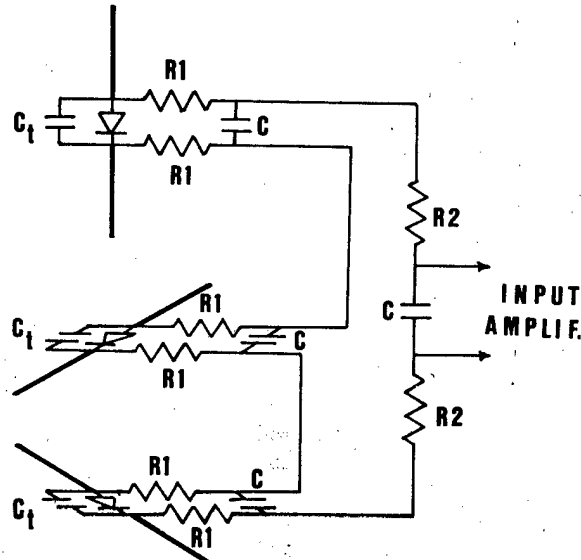

Fig. 3 - Isotropic probe schematic.  $C_t$ : flattening capacitance;  $R_1$ ,  $C$  and  $R_2$ : filtering circuit.

to the diode, so that the antenna voltage turns out to be applied to the diode through a capacitive divider. The value  $C_t$  of this capacitance is selected so as to extend the frequency flatness down to the cut-off value  $(2\pi C_t R_j)^{-1}$ , where  $R_j$  is the junction resistance of the diode.

The flat response band is limited at high frequencies by the increasing of the effective length and capacitance of the antenna.

The probe design criteria were essentially those proposed by the American NBS [6], and already adopted in other field meters [7]. The dipole is so dimensioned that its effective length and capacitance remain practically constant (within ~1%) up to 200 MHz. The total bandwidth of the probe depends also on the diode and filter parameters; it can be shown that an upper cut-off frequency exists,  $f_c \approx (2\pi R_s C_j)^{-1}$  where  $C_j$  and  $R_s$  are the junction capacitance and the series resistance of the diode.

As detector, a germanium diode OA 90 was selected for its soft characteristic and low cost (0.1 \$). Taking into account the range of parameter variation of this type of diode, a minimum cut-off frequency of more than 200 MHz can be obtained. The bandwidth 1 MHz to 200 MHz is more than adequate to include the fundamental frequency and the significant harmonics produced by RF heating machines. We point out that this germanium point-contact diode, still maintaining (in the selected frequency band) the same performance of a more expensive low barrier Schottky diode, allows to obtain a low-cost field probe, which is a basic design feature of this type of instrument.

The probe is followed by a suitable filtering circuit which provides a block to RF currents induced on the instrument body by the fields and by operator touch; the soft characteristic of the diode helps to further reduce the effect of unwanted couplings. Insensitivity to such unwanted couplings is another essential feature of the instrument: this is of course a different matter than the perturbation of the field by the presence of the operator. Unwanted coupling would produce meaningless readings for any meter or monitor.

The size of the foam protective sphere (see Fig. 1) is such that signal pick up due to capacitive coupling of the antenna to nearby metallic objects is reduced to negligible levels.

The detected signal is amplified and compared (see Fig. 4) to two fixed voltages  $V_A$  and  $V_B$ : the

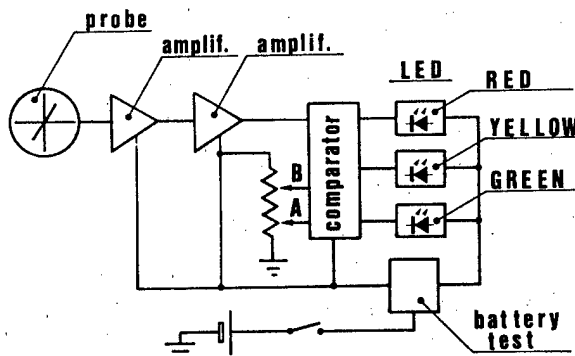

Fig. 4 - Block diagram of the RF Hazard Monitor.

output of the comparator drives the display LED's as follows. When the signal voltage  $V$  is less than  $V_A$  a green light is on; for  $V_A < V < V_B$  the green light is turned off and a yellow light is turned on; for  $V > V_B$  a red light is turned on and all the others are off. Only one light is on at a time. The voltages  $V_A$  and  $V_B$  are preset at the calibration stage; the probe is introduced into a calibration cell where a field value is established according to the safety standards. In the absence of Italian safety regulations we stated the following rationales for fixing the reference levels.

It is universally accepted that a thermal hazard exist. Exposure to e.m. field at "thermal" levels should be forbidden. The new USA safety standards limit the permissible absorption to a fraction of the Basal Metabolic Rate, taking into account the resonant absorption in the frequency range where heating machines usually operate. We selected the level of 150 V/m for the switching between yellow and red light (i.e.  $V_B$  reference level). This corresponds to a value where at least 1 minute of exposure is allowed according to the recent USA recommendations [8].

On the other hand the most restrictive standards (USSR) are fixed at a fraction of field level at which any effect couldn't be observed. Exposure to fields within that limit appears to be completely safe and unlimited exposure is permissible. Confining our attention to the HF (3 MHz to 30 MHz) we adopt the level of 20 V/m for the switching between green and yellow light. (i.e.  $V_A$  reference level). Between the red (forbidden) and the green (safe) zone, the field levels are such that a prolonged exposure should be avoided, but sporadic and brief (less than one minute) exposure do not cause real harm or serious concern. Of course, if different safety regulations were assumed, it would be sufficient to reset the  $V_A$  and  $V_B$  levels.

The response of the instrument is frequency independent in a band (1 MHz to 200 MHz) where safety standards are not. For example the Soviet Standards have different levels in the frequency ranges 3 MHz to 30 MHz (20 V/m); 30 MHz to 50 MHz (10 V/m); 50 MHz to 300 MHz (5 V/m). Although the majority of heating machines works in the band of 3 to 30 MHz, some harmonic generation can occur. We can assume that in practice they decrease as  $1/n^2$  or faster, where  $n$  is the order of the harmonic. The square-law detection will then take their contribution into safe account. For instance a 27 MHz plastic sewing machine, producing at a certain point a field of 19,5 V/m, could generate a second harmonic field of 4,9 V/m. Both fields are just below the USSR safety levels, while the monitor will cautiously light the yellow LED.

A  $\pm 3$  dB (but usually better) accuracy is easily obtained in the RF Hazard Monitor, which is the typical accuracy offered by higher class, commercial field meters. This accuracy includes frequency response, calibration errors, isotropy errors and temperature variations.

In order to obtain maximum simplicity in the use, only the ON/OFF switch is provided.

The instrument is battery operated. A battery test circuit is provided (Fig.4): with the power switch ON, one of the LED's must be on. This shows the operator that the battery is charged.

The laboratory prototype weighs 0,5 kg (including Ni-Cd rechargeable batteries), is 33 cm from the top of the sphere to the bottom of the cabinet. This is the maximum dimension. The cabinet is 15 cm x 7 cm x 4 cm. No special effort was spent towards miniaturization or weight reduction.

#### CONCLUSION

The RF Hazard Monitor is a practical answer to the problem of health protection of the personnel operating radiofrequency heating machines. It can also be useful tool in all the problems where the RF fields have to be tested in relation to a safety standard. Its main technical characteristics are: isotropic response, insensitivity to unwanted couplings, simplified read-out correlated to pre-settable safety standards.

It has been designed for low cost, so that widespread availability is possible. Its ease of use does not require any specialized personnel.

This instrument will permit a frequent and inexpensive monitoring of each heating machine, avoiding human exposure to hazardous fields but also avoiding undue concern where the field levels are within accepted safety standards.

#### REFERENCES

- 1 M.Bini, A.Ignesti, L.Millanta, N.Rubino, R.Vanni: *A comparative analysis of the various polluting RF sources*, "Alta Frequenza" vol. XLIX, 1980, p.76.
- 2 M.Bini, A.Ignesti, L.Millanta, N.Rubino, R.Vanni: *Hazard Monitor for RF electric and magnetic fields*, Italian Patent 9397 A/80, 1980.
- 3 R.F.Cleveland, J.K.Kielman, Z.R.Glase: *Biological effects of radiofrequency and microwave radiation and their relevance to occupational safety and health standards in the United States*, 1979 Microwave Power Symposium Monaco, 1979.
- 4 M.A.Stuchly, M.M.Repacholi, D.Lecuyer, R.Mann: *Radiation survey of dielectric (RF) heaters in Canada*, J.Microwave Power, vol. 15, 1980, p.113.

- 5 M.Bini, A.Ignesti, L.Millanta, N.Rubino, R.Vanni: *Hazards of electric fields generated by dielectric heating machines: exposure levels measurements*, Proceedings of LXXXI AEI Annual Convention, Trieste 1980, p.I-43 (in Italian).
- 6 F.M.Greene: *Development of electric and magnetic field probes*, NBS TN-658, Jan. 1975.
- 7 L.Bolla, G.Gerbi: *An electric and magnetic field meter*, Alta Frequenza vol. XLIX (1980), p. 150.
- 8 *Environmental health criteria 16: radiofrequency and microwaves*, world Health Organization, Geneva 1981.

Manuscript received on April 23, 1981

CSO: 5000/2501

END