

R

354051

JPRS 81942

7 October 1982

# China Report

SCIENCE AND TECHNOLOGY

No. 176

19980831 084

**FBIS**

FOREIGN BROADCAST INFORMATION SERVICE

REPRODUCED BY  
NATIONAL TECHNICAL  
INFORMATION SERVICE  
U.S. DEPARTMENT OF COMMERCE  
SPRINGFIELD, VA 22161

9  
25  
A02

#### NOTE

JPRS publications contain information primarily from foreign newspapers, periodicals and books, but also from news agency transmissions and broadcasts. Materials from foreign-language sources are translated; those from English-language sources are transcribed or reprinted, with the original phrasing and other characteristics retained.

Headlines, editorial reports, and material enclosed in brackets [ ] are supplied by JPRS. Processing indicators such as [Text] or [Excerpt] in the first line of each item, or following the last line of a brief, indicate how the original information was processed. Where no processing indicator is given, the information was summarized or extracted.

Unfamiliar names rendered phonetically or transliterated are enclosed in parentheses. Words or names preceded by a question mark and enclosed in parentheses were not clear in the original but have been supplied as appropriate in context. Other unattributed parenthetical notes within the body of an item originate with the source. Times within items are as given by source.

The contents of this publication in no way represent the policies, views or attitudes of the U.S. Government.

#### PROCUREMENT OF PUBLICATIONS

JPRS publications may be ordered from the National Technical Information Service, Springfield, Virginia 22161. In ordering, it is recommended that the JPRS number, title, date and author, if applicable, of publication be cited.

Current JPRS publications are announced in Government Reports Announcements issued semi-monthly by the National Technical Information Service, and are listed in the Monthly Catalog of U.S. Government Publications issued by the Superintendent of Documents, U.S. Government Printing Office, Washington, D.C. 20402.

Correspondence pertaining to matters other than procurement may be addressed to Joint Publications Research Service, 1000 North Glebe Road, Arlington, Virginia 22201.

JPRS 81942

7 October 1982

# China Report

SCIENCE AND TECHNOLOGY

No. 176

**FBIS**

FOREIGN BROADCAST INFORMATION SERVICE

CHINA REPORT  
SCIENCE AND TECHNOLOGY

No. 176

CONTENTS

PEOPLE'S REPUBLIC OF CHINA

NATIONAL DEVELOPMENTS

- Over 900 Postgraduates for Doctoral Degrees To Be Enrolled  
(RENMIN RIBAO, 29 Aug 82)..... 1

APPLIED SCIENCES

- Fiber-Optic Angular Rate Sensor With Stabilizer Circuit  
Described  
(Yan Wanchang; JIGUANG, No 12, 1980)..... 3

LIFE SCIENCES

- Prevention, Treatment of Occupational Diseases Studied  
(Sun Yongsheng; RENMIN RIBAO, 18 Jul 82)..... 10
- New Model Cardiovascular Cardioverter Developed  
(Ye Lifei; GUANGZHAOU RIBAO, 28 Jun 82)..... 12

ABSTRACTS

ARMAMENTS

- BINGGONG XUEBAO [ACTA ARMAMENTARII], No 3, Aug 82..... 14

COMPUTER RESEARCH

- JISUANJI YANJIU YU FAZHAN [COMPUTER RESEARCH AND DEVELOPMENT],  
No 8, 1982..... 15

MECHANICAL ENGINEERING

DONGLI GONGCHENG [POWER ENGINEERING], No 4, 15 Aug 82..... 16

METALS

YOUSE JINSHU [NONFERROUS METALS], No 3, Aug 82..... 17

## NATIONAL DEVELOPMENTS

### OVER 900 POSTGRADUATES FOR DOCTORAL DEGREES TO BE ENROLLED

Beijing RENMIN RIBAO in Chinese 29 Aug 82 p 3

[Article: "119 Institutes of Higher Learning and Scientific Research Organizations in the Country Plan to Enroll More Than 900 Postgraduates for Doctoral Degrees This Year"]

[Text] According to the XINHUA News Agency, China plans to enroll more than 900 postgraduates for doctoral degrees in 1982. The recruitment of students will begin in the latter part of August.

In 1982, a total 119 institutes of higher learning and scientific research organizations (excluding the Chinese Academy of Social Sciences) will enroll postgraduate students for doctoral degrees. These will include 691 students planned for enrollment by 92 institutes of higher learning with 412 specialities [Zhuanye dian 1413 2814 7820] and 509 advisors; 145 students by the five academic departments of the Chinese Academy of Science with 61 specialities and 104 advisors; 44 students by 17 ministries and commissions under the State Council and provincial and municipal scientific research organizations with 27 specialities and 32 advisors, and 24 students by five military schools with 17 specialities and 23 advisors.

According to the "Provisional Regulation for the Enrollment of Postgraduate Students for Doctoral Degrees" (referred to as Regulations below), persons meeting the following requirements may register for examinations for doctoral students this year: (1) familiar with the basic principles of Marxism-Leninism and Mao Zedong Thought and adherence to the four basic principles of good conduct, discipline and law abiding, diligence, and determination to serve the modern construction of socialism; (2) working persons with a master's degree, students due to receive their master's degree (able to receive a master's degree before acceptance at the latest), or persons with equivalent scholastic ability; (3) in good health and, in general, less than 40 years of age; (4) recommendation by two assistant professors (or persons with equivalent title) or higher ranking specialists in the applicant's related field.

The application date will be determined by individual enrollment units. Applicants meeting the requirements may review the "Catalogue on Special Subjects for National Enrollment of Postgraduates for Doctoral Degrees in 1982" released by the Ministry of Education at the admissions offices of the nearest provincial,

municipal, or autonomous region institutes of higher learning or related institutes of higher learning and scientific research organizations.

The "Regulation" emphasizes that at the time the person meeting the requirements makes his application the unit where he is located must transmit the following documents to the enrolling unit: application for examination of doctoral student, letters of recommendation from specialists, transcripts for the master's degree, master's thesis and evaluation, master's diploma or certificate, physical examination paper, and political evaluation paper. Students due to receive their master's degrees must submit their master's diploma before acceptance. Persons with equivalent scholastic abilities will not be required to submit materials related to master's transcripts and diplomas, however, they should submit a list of courses taken towards master's degrees and academic papers published in public publications which are equivalent to a master's thesis.

The "Regulation" also states that this year's enrollment of postgraduate students for doctoral degrees combines examinations with recommendations and written examinations with oral examinations. Subjects of examination generally include theories of Marxism-Leninism, foreign languages, and professional topics. The number of professional topics is determined by the enrolling unit. In addition to written and oral examinations, the enrolling unit may require other necessary tests. The examination date is determined by the individual enrolling units.

The "Regulation" points out that the training goals for the enrollment of postgraduate students for doctoral degrees are: overall moral and intellectual development, a firm and broad grasp of basic theories and an in-depth specialized knowledge in the specific field of study, possession of independent ability for scientific research, and high level scientific and specialized talents with creative results in science or special technology. Therefore, it is hoped that the units will proceed from the overall situation, actively support personnel meeting the requirements, and provide talent to the state.

5974  
CSO: 4008/222

FIBER-OPTIC ANGULAR RATE SENSOR WITH STABILIZER CIRCUIT DESCRIBED

Shanghai JIGUANG [LASER JOURNAL] in Chinese No 12, 1980 pp 32-35

[Article by Yan Wanchang [7051 8001 2490], National Defense Scientific and Technical University: "A Fiber-Optic Angular Rate Sensor with a Stabilizer Circuit"]

[Text] ABSTRACT: The addition of a stabilizing feedback circuit to a polarized ring laser interferometer is described. The compensation method is used to measure optical path difference, thus allowing increased stability of the angular rate sensor output and decreased interference error and ensuring accuracy.

Introduction

Since 1963 the laser gyroscope has been attracting great attention everywhere. Because it has no moving parts, its spinup time is short, its power consumption is small and it can withstand high acceleration and impact, it has great promise for use in flight, including applications to missiles and space flight. As a result of more than 10 years of energetic research and development work, such devices as the GG-1300 laser gyroscope have been developed [1]. But its temperature sensitivity and proneness to frequency locking are hindering the improvement of its capabilities [2], so that it has not gone into extensive use. The main problems of instability and frequency locking caused by heat production in the active ring resonator and scattering and losses in the mirrors are hard to solve. Major efforts in recent years have produced some progress, such as the development of the differential laser gyro design [3], and have partially solved this problem, but reports indicate that it is still in the developmental stage. Recently, passive-resonator laser gyros [4] and fiber-optic gyroscopes [5-8] have been proposed. These gyroscopes or angular rate sensors have no frequency lock-in region and their stability is good, so that they have overcome the difficulties encountered in the case of active ring-laser gyroscopes, but their sensitivity is still rather poor. One way of solving this problem is the use of a stabilizer circuit to create a closed-loop system, which is in reality a compensation method. This method has been extensively used in many types of measuring equipment and has been shown

to be effective. The present article discusses the operating principles of such a laser angular rate sensor and presents block diagrams and a proposed design implementation.

### Operating Principles

The operating principles are illustrated in Fig. 1. The directionally stable coherent light emitted by laser L passes through a 45° polarizer plate P to beamsplitter B, which divides the beam into two beams of equal intensity. One beam passes through polarizer P<sub>1</sub>, which gives it p-polarization, then is reflected by oblique mirror M<sub>1</sub> and is passed through a quarter-wave plate to give it left-handed circular polarization; after passing through Faraday cell F it passes through another quarter-wave plate. This plate must be so located that when the left-hand circularly-polarized beam passes through it, it becomes s-polarized. The beam then passes through polarizer plate P<sub>2</sub> perpendicular to P<sub>1</sub>, then proceeds to beamsplitter B, completing a circuit, and is reflected. Similarly, the other beam exiting from the beamsplitter completes a circuit in the opposite direction through P<sub>2</sub>, M<sub>2</sub>, one quarter-wave plate, F, the other quarter-wave plate, M<sub>1</sub>, P<sub>1</sub> and B. Obviously this beam is s-polarized after passing through P<sub>2</sub>, and when it passes through the first quarter-wave plate it becomes right-hand circularly-polarized; then, after passing through the second quarter-wave plate, it becomes p-polarized. Thus when the two beams exit via B they form a combination of p-polarized and s-polarized light.

When this optical circuit is not rotating around an axis perpendicular to the plane of the laser path, the two beams travel equal paths, and when exiting from B they have the same phase, so that the composite beam should be linearly polarized at 45°. When the circuit is rotating around an axis perpendicular to its plane, the counterrotating beams have an optical path difference. The beam traveling in the direction of rotation has an increased path length and that traveling in the opposite direction has a decreased path length. Then the two beams exiting from B will have different phases, and the product of their combination will be elliptically polarized. The direction of rotation of this elliptically polarized beam will be the same as the direction of rotation of the system.

In order to extract the information from this beam we use a lithium niobate electrooptical modulator N. The lithium niobate crystal passes light along its Z axis, while a voltage is applied along the Y axis, producing a transverse electrooptic effect. When the voltage satisfies the condition

$$V = \frac{\lambda}{4n_0^3 r_{22}} \cdot \frac{d}{l} \quad (1)$$

the effect of the crystal is equivalent to that of a quarter-wave plate. In the formula,  $\lambda$  is the wavelength of the light,  $n_0$  is the principal refractive index of the crystal for the ordinary wave,  $r_{22}$  is an element of the electro-optical coefficient matrix for the crystal,  $d$  is the thickness of the crystal between the electrodes, and  $l$  is the length of its Z axis. The crystal is mounted so that its Y axis is at an angle of 45° to the direction of polarization of the p-polarized and s-polarized waves. The voltage applied to the crystal is a square wave with the voltage given by equation 1.

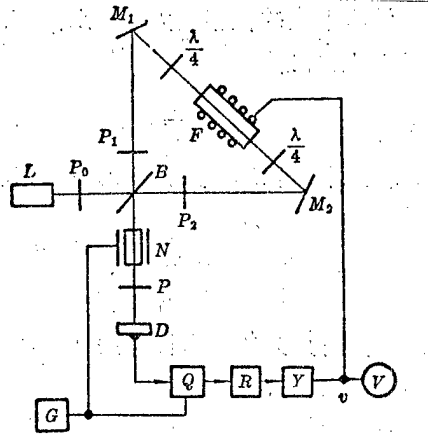

Fig. 1. Operating principles of device.

With no rotation in the system, when the p-polarized and s-polarized beams, which have the same phase, pass through the crystal during the positive half-wave of the applied voltage they are combined into a circularly-polarized beam, and during the negative half-wave they are combined into a circularly-polarized beam with the opposite direction of rotation. The composite beam exiting from the crystal passes through an analyzer P oriented along the Y axis of the crystal, then is received by photodetector D which converts it to an electrical signal. Obviously a transformed signal in which the amplitudes corresponding to the positive and negative half-waves of the crystal modulating voltage are equal will be obtained.

When the system has a rotational input, the phases of the p-polarized and s-polarized beams will differ when they enter the crystal, and as a result of modulation in the crystal the voltage produced by the detector will have different amplitudes in the positive and negative half-waves. By comparing these signals in a phase detector, an AC output voltage which is a certain function of the input rotation can be obtained. The linear reference circuits of phase detector Q and comparator R are shown in Fig. 2. In the figure,  $u_1$  and  $u_2$  are AND gates and  $f$  is a NOT gate:  $u_1$  outputs the signal for the first half-wave and  $u_2$  outputs that for the second half-wave. The two signals

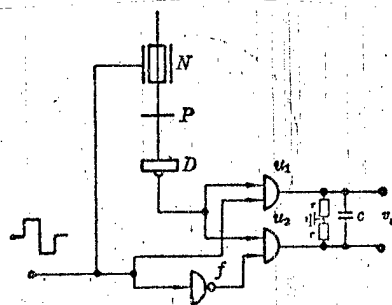

Fig. 2. Linear reference circuit of phase detector and comparator.

are compared by applying them to the two arms consisting of resistors  $r$ , and filter capacitor  $C$  yields a DC output signal  $v_g$ .

In an open-loop system, the signal  $v_g$  is amplified to  $v$  and constitutes the rate sensor output: its positive or negative value indicates the direction of rotation. For a rate sensor with a stabilizer circuit, i.e. a closed-loop system, the signal  $v$  must be fed back to the winding of the Faraday cell  $F$  in the ring resonator, thus correcting the path difference of the counter-rotating beams. The output signal  $v$  is still used as the rate sensor output, and can be read out during experiments as a digital voltage value  $V$ .

### Block Diagram of the System

For simplicity we assume that the two beams are propagating in opposite directions around a circular path (Fig. 3). The angular velocity of the

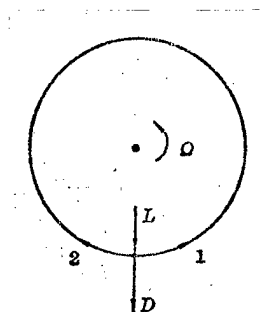

Fig. 3. Optical rotation system.

system is  $\Omega$ , and the laser  $L$  and detector  $D$  are both in the rotating system. Thus the light is emitted from  $L$  and propagates in two different directions around the circular path to point  $D$ , when the path difference  $\Delta$  of the two beams is:

$$\Delta = \Delta_1 + \Delta_2$$

where  $\Delta_1$  and  $\Delta_2$  are the differences in path length imparted to beams 1 and 2 as a result of the rotation. They can be determined from the formulas

$$\frac{\Delta_1}{\Omega R} = \frac{2\pi R}{c}$$

$$\frac{\Delta_2}{-\Omega R} = \frac{2\pi R}{-c}$$

where  $R$  is the radius of the circular path and  $c$  is the speed of light. Thus we obtain

$$\Delta = \frac{4A}{c} \Omega \quad (2)$$

where  $A = \pi R^2$  is the area enclosed by the optical path. It can be proved that equation 2 is equally valid for a noncircular path.

If the phase difference between the two beams is  $\varphi$ , then  $\varphi$  and  $\Delta$  will be proportional:

$$\varphi = \frac{2\pi}{\lambda} \Delta \quad (3)$$

If the wave formulas for the two beams before they pass through the crystal are

$$\begin{aligned} i_1 &= I \sin \omega t \\ i_2 &= I \sin(\omega t + \varphi) \end{aligned}$$

where  $I$  is the optical intensity for each beam, then after they have passed through the electrooptic modulator crystal the formulas are

$$\begin{aligned} i_1(+) &= I \sin\left(\omega t + \frac{\pi}{2}\right) \\ i_2(+) &= I \sin(\omega t + \varphi) \end{aligned}$$

for the first half-wave and

$$\begin{aligned} i_1(-) &= I \sin\left(\omega t - \frac{\pi}{2}\right) \\ i_2(-) &= I \sin(\omega t + \varphi) \end{aligned}$$

for the second half-wave. When depolarizer  $P$  has the same direction as the  $Y$  axis of the crystal, the combination of the two waves after passage through  $P$  will be

$$i_Y(+) = -i_1(+) \cos 45^\circ + i_2(+) \sin 45^\circ$$

for the first half-wave, from which we can determine the amplitude of the combined beam (in the  $Y$  direction):

$$I_Y(+) = \sqrt{2} I \sin \frac{\varphi - \frac{\pi}{2}}{2}$$

Similarly, in the second half-wave we have

$$I_Y(-) = \sqrt{2} I \sin \frac{\varphi + \frac{\pi}{2}}{2}$$

When the light intensities from the two half-waves are converted into electrical signals by the same photodetector, passed through phase detectors and applied to the two resistors for comparison, the output voltage  $v_g$  is

$$v_g = K_g 2I^2 \sin \varphi$$

where  $K_g$  is the conversion factor for the photodetector and phase-detector-comparator unit. For a closed-loop system with negative feedback,  $\varphi$  will be very small, so that

$$v_g \approx K_g 2I^2 \varphi \quad (4)$$

Signal  $v_g$  can be proportionately amplified by a linear amplifier, but in order to eliminate steady-state error and high-frequency noise an integral amplifier may be used. Its transfer function may be written as

$$W(S) = \frac{K_v}{S}$$

where  $K_v$  is the proportionality factor of the integral amplifier and  $S$  is the

Laplace operator. Thus the amplifier output voltage is

$$v = \frac{K_v}{S} v_g \quad (5)$$

If the conversion factor for the Faraday cell is  $K_F$  and the optical path which it compensates is  $\Delta'$ , then

$$\Delta' = K_F v \quad (6)$$

Using the conversion relationships of equations 2-6 we can draw a block diagram for the stabilizer-circuit optical angular rate sensor as in Fig. 4.

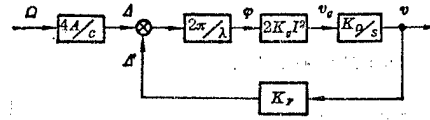

Fig. 4. Block diagram of system.

From the block diagram we obtain

$$v = \frac{K_D}{TS+1} \Omega \quad (7)$$

where  $T = \frac{1}{K_v 2K_g I^2 \frac{2\pi v}{\lambda} K_F}$  is the time constant of the system and  $K_D = \frac{4A}{CK_F}$

is the scale factor for the laser angular rate sensor. It is apparent from equation 7 that the system has a typical aperiodic characteristic. In a steady state,

$$v = K_D \Omega \quad (8)$$

gives the simple linear relationship between the output voltage and input angular velocity. Eq. 8 indicates the special characteristics of the laser angular rate sensor when equipped with a stabilizer circuit. The scale factor and the steady-state precision are related only to the conversion factor  $K_F$  of the feedback element and the area enclosed by the optical path and are unaffected by other parameters. Increasing  $A$  is an effective way of increasing the sensitivity of the sensor, while decreasing  $K_F$  affects the feedback function. Using the polarization interference method increases the resolution of the detector, raising its detection threshold. The degree of instability  $A/K_F$  is the steady-state relative error of the sensor. The system is not sensitive to constant interference and has little response to high-frequency interference, but it still has error produced by such dynamic interference as amplifier drift, photodetector noise and instability in the light intensity and light source directionality. By suitably choosing the system time constant  $T$ , these types of interference can be decreased.

## A Proposed Design

A simple design proposal is shown in Fig. 5. A helium-neon laser or semiconductor laser may be used for L. After passing through a 45° polarizer plate  $P_0$  the light is divided into two beams of equal intensity by a beam-splitter; one beam passes through polarizer plate  $P_1$ , a quarter-wave plate and condenser  $T_1$ , then into an optical fiber, while the other beam passes through  $P_2$ , a half-wave plate, Faraday cell F and condenser  $T_2$ , then into the optical fiber. The fast axes of the two quarter-wave plates must be parallel so that the two counterrotating beams passing through the Faraday cell and optical fiber will be circularly polarized and so that when leaving the circular optical path they will be linearly polarized in mutually perpendicular directions. The feedback output circuit is as described above and will not be discussed again here. This device is packaged as a single unit and has no moving parts.

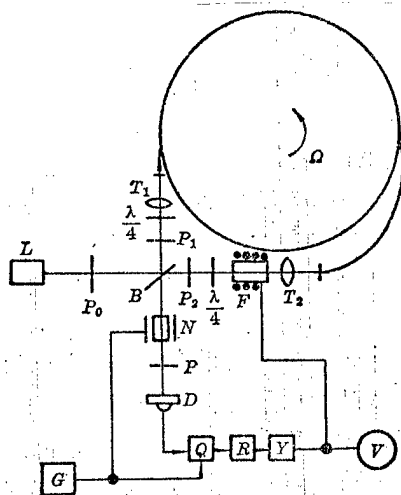

Fig. 5. Diagram of proposed design.

## BIBLIOGRAPHY

1. AVIATION WEEK AND SPACE TECHNOLOGY, Vol. 99, No. 18, 60 (1973).
2. Morrison, Robert F. AD/A-001646.
3. Bresman, J. et al., NAVIGATION, Vol. 24, No. 2 (1977).
4. Ezekiel, S., and Balsamo, S. R. APPL. PHYS. LETT., Vol. 30, No. 9, 478 (1977).
5. ELECTRONIC DESIGN, Vol. 23, No. 15, 22 (1975).
6. Ulrich, R., and Johnson, M. OPT. LETT., Vol. 4, No. 5, 152 (1979)
7. Vali, V., and Shorthill, R. W. APPL. OPT., Vol. 15, 1099 (1976).
8. Thompson, D. E. et al., APPL. PHYS. LETT., Vol. 33, 940 (1978).

8480

CSO: 8111/1799

LIFE SCIENCES

PREVENTION, TREATMENT OF OCCUPATIONAL DISEASES STUDIED

Beijing RENMIN RIBAO in Chinese 18 Jul 82 p 3

[Article by Sun Yongsheng [1327 3057 4141]: "Tianjin Actively Expands Work to Prevent and Treat Occupational Diseases"]

[Text] The Tianjin Municipal Public Health Bureau has adopted practical measures to expand work to prevent and treat occupational diseases. Since 1979, they have conducted health inspections of the work environment in over 2,000 factories, and physically examined 90,000 workers whose work involves dust or toxic substances, in order to protect the health of the staff and workers.

Since the Third Plenum of the 11th Party Central Committee, the City of Tianjin has restored and strengthened organizations for industrial hygiene and the prevention and treatment of occupational diseases. Personnel and facilities have been increased. The Municipal Public Health Bureau has allocated almost 2,000,000 yuan for work in industrial hygiene and the prevention and treatment of occupational diseases. In all wards of the city, the county public health and epidemic prevention stations have set up labor health sections (teams), while the hospitals of each ward have set up an occupational disease section. Since 1979, almost 1,000 medical personnel have been organized throughout Tianjin, to go right to the factories where work is done involving dusts and toxic substances to carry out surveys of many kinds of ailments. In conducting the survey, they adhered to the principle of simultaneous investigation, treatment, and prevention. By the end of last year, they had discovered 1,864 persons suffering from occupational diseases caused by the 5 toxic substances, lead, benzene, mercury, organic phosphorus, and trinitrotoluene. They treated 1,850 persons, or 99.2 percent. The municipal public health and epidemic prevention stations, in cooperation with the relevant industrial departments, also carried out investigations for occupationally related tumours at 159 factories.

While making the survey of occupational diseases, the public health departments made suggestions for improvements in production technology and safety equipment in the factories where work is done involving dust or toxic substances. Eight hundred and seven factories worked out measures for improving working conditions.

Recently, the Tianjin Municipal Public Health Bureau joined together with the Municipal Economic Commission, the Trade Union Federation, the Labor Bureau, and the Medical Management Bureau, to hold a city-wide meeting to sum up the occupational diseases survey, and to commend 33 advanced collectives and 40 advanced persons for their achievements in the occupational disease survey and in the work to bring the hazards of dust and toxic substances under control.

12187

CSO: 4008/207

LIFE SCIENCES

NEW MODEL CARDIOVASCULAR CARADIOVERTER DEVELOPED

Guangzhou GUANGZHAOU RIBAO in Chinese 28 Jun 82 p 1

[Article by reporter Ye Lifei [0673 7787 5481]: "A new Model Cardiovascular External Cardioverter Successfully Developed in Guangzhou; 90 Percent Effective in Treating Angina Pectoris of Coronary Heart Disease"]

[Text] At the recently concluded "WFB-II Model Sequential Type External Cardioverter Evaluation Meeting:", a reporter from this newspaper learned that the Guangzhou Medical Apparatus and Instruments Factory and the Artificial Heart Laboratory of the Zhongshan Medical Academy have succeeded in developing through cooperative research a new model cardiovascular external cardioverter, which has a far greater curative effect than the usual sequential type cardioverter applied to the four limbs. The new device is 90 percent effective in treating the anginal pain of coronary heart disease. The experts from 29 provinces and cities unanimously concluded that the sequential external cardioverter, which has been developed first in China, is a new achievement in the technology of treating coronary heart disease and diseases involving insufficient blood to the brain.

At present, the external cardioverter used in foreign countries is, for the most part, the non-sequential positive/negative pressure cardioverter, which is applied to the legs. Since this type of device is not rational in design, the diastolic pressure cannot be raised to the appropriate level. As a result, it is gradually falling into disuse. The scientists and technicians, and the technical personnel of the Guangzhou region have been making bold innovations and tackling key problems together for many years. In 1976 they successfully developed the Model I external cardioverter. In order to further improve effectiveness, the Guangzhou Medical Apparatus and Instruments Factory and the Zhongshan Medical Academy have carried out meticulous research since 1980, successfully developing the new model WFB-II Sequential External Cardioverter. This new model device is far more effective, and is a significant advance over the original Model I in terms of the performance of its electrical and mechanical systems. In clinical use, the symptoms of angina pectoris disappeared in 90 percent of the cases; there was a significant improvement in the remainder of the cases, many patients who were seriously ill improved rapidly. One patient had suffered anginal pains for over 20 years. Before treatment he would suffer heart

pains and shortness of breath when walking quickly on level ground for 20 meters, or when bathing, or eating. During serious spells he would suffer pain 3 or 4 times daily. After 36 cardioversion treatments using this new model device, the symptoms rapidly improved. After terminating the use of all medications for anginal pains, the patient was able to climb five stories without heart pains or shortness of breath. He was also able to climb the 200 meters to Tian Lake in Conghua County, ascending and descending the slope just like everyone else.

12187

CSO: 4008/207

AUTHOR: PAN Chengpan [3382 2110 3140]

ORG: None

TITLE: "Accuracy Estimation and Testing for Fire Control System of Antiaircraft Weapons"

SOURCE: Beijing BINGGONG XUEBAO [ACTA ARMAMENTARII] in Chinese No 3, Aug 82  
pp 1-12

TEXT OF ENGLISH ABSTRACT: This paper deals with the method of describing the accuracy of the fire control system of aircraft weapons during firing and studies the principle and method of the accuracy estimation and testing according to the features of the error process in that system. In this paper, statistical characteristics of some statistics, such as instantaneous accuracy estimator  $\hat{\alpha}_i$  and  $\hat{\delta}_i$ , accuracy estimator in a short time interval  $\hat{\alpha}(j)$  and  $\hat{\delta}(j)$ , mean accuracy estimator in whole time interval  $\bar{\alpha}$  and  $\bar{\delta}$ , etc. are analyzed. Their distributions and expectations and variances have been deduced. Moreover, an example is cited to explain the procedure in applying the principle stated above. This paper was received for publication on 20 Sep 80.

AUTHOR: SHI Kexin [0670 0668 0207]  
WAN Bangzhi [8001 6721 1807]

ORG: None

TITLE: "Stiff Optimum Design of Radar Antenna Structures"

SOURCE: Beijing BINGGONG XUEBAO [ACTA ARMAMENTARII] in Chinese No 3, Aug 82  
pp 47-62

TEXT OF ENGLISH ABSTRACT: This paper presents the concept of stiff optimum design, based on real design requirements of radar antenna structures. An optimality criterion of plate-truss composite antenna structures has been developed by using surface accuracy of the antenna as main constraint, both cross-sectional areas of bars and thicknesses of plane stress plates as design variables as well as the weight of the antenna structure as objective function. Through alternatively optimum design, we have obtained an optimal structure which not only meets design requirements but also has the lightest weight. Thus, it is an efficient and convenient approach, which will be extensively used. Through both calculation of two examples and comparison with solutions obtained by common design algorithm, it has been shown that the algorithm has efficiency and utility.

This paper was received for publication on 17 Oct 80.

6248

CSO: 4009/398

AUTHOR: ZHONG Xun [0112 6598]

ORG: None

TITLE: "Vigorous Development of Science Exchange With Organizing of Chinese Language Information Processing Study Group in China"

SOURCE: Beijing JISUANJI YANJIU YU FAZHAN [COMPUTER RESEARCH AND DEVELOPMENT] in Chinese No 8, 1982 p back cover

ABSTRACT: The study of data processing in Chinese characters is a new science, relating to linguistics, computer science and technology because there are thousands of distinct characters. New challenges will appear in the character input into a computer, character printer, computer discrimination of characters, and data processing of characters. The Chinese Language Information Processing Study Group was founded in June 1981 following approval by the China Scientific and Technical Association. The group has an office in the Computer Technology Institute of the Chinese Academy of Sciences. The chairman of the study group is professor Qian Weichang [6929 0251 7022] of the Qinghua University; the secretary general of the group is Xu Kongshi [6079 1313 2514], an associate researcher of the Computer Technology Institute. In August 1983, the study group will sponsor at Beijing a Chinese Language Information Processing International Discussion Conference. Small exhibitions will be displayed at the conference; notifications on conference rules and theses solicitation will be mailed to concerned parties in the immediate future.

10424

CSO: 4009/395

Mechanical Engineering

AUTHOR: None

ORG: Shanghai Office, Institute of Power System

TITLE: "Convening of All China Central Heat Supply Science Conference at Beijing"

SOURCE: Shanghai DONGLI GONGCHENG [POWER ENGINEERING] in Chinese No 4, 15 Aug 82  
p 51

ABSTRACT: From 5th to 11th May, a Central Heat Supply Science Conference was held at Beijing; the conference was jointly sponsored by the China Mechanical Engineering Society and China Electric Engineering Society. More than 260 delegates took part in the conference. Li Renjun [2621 0086 0193], an advisor to the State Planning Commission, and Huang Yicheng [7806 3015 6134], deputy director of the commission, attended the conference; Huang delivered a scientific report. The conference discussed the five following topics: (1) several approaches to remodeling condenser power systems into heat supply systems; (2) construction of power plants for individual plants and for small- and intermediate-sized areas, as well as power generation with differential pressures; (3) construction of large regional power stations; (4) fundamental theory and selection of equipment for central heat supply systems; and (5) construction of boiler rooms and heat supply piping for central heat supply systems. In addition, discussions were held on heat value, management of central heat supply system, the concept of heat supply in Beijing, and an evaluation of economic effect.

AUTHOR: None

ORG: Shanghai Office, Institute of Power System

TITLE: "Third Nuclear Power Science Conference"

SOURCE: Shanghai DONGLI GONGCHENG [POWER ENGINEERING] in Chinese No 4, 15 Aug 82  
p 76

ABSTRACT: From 23 to 26 April 1982, the Third Nuclear Power Science Conference was held at Wuhan; the conference was jointly sponsored by the China Mechanical Engineering Society and Power Engineering Society. This conference was vigorously supported by the Hubei Provincial Mechanical Engineering Society, and was organized by the Wuhan Boiler Plant. Altogether 67 delegates from 33 units took part in the conference; 25 theses were discussed, including safety guidelines and economic analysis in designing nuclear reactor power plants, as well as the evaporator, main pumps, and components in the reactor. The participating delegates engaged in a vigorous discussion of scientific activities for three to five years into the future.

10424

CSO: 4009/394

AUTHOR: XU Ding [1776 7844]

ORG: Beijing Central Design and Research Institute for Nonferrous Metallurgical Industry

TITLE: "Surface Hydraulic Mining of Placer in China"

SOURCE: Beijing YOUSE JINSHU [NONFERROUS METALS] in Chinese No 3, Aug 82 pp 1-7

TEXT OF ENGLISH ABSTRACT: Surface hydraulic mining of placer has been practiced in the People's Republic of China for a long time. The principal mining method employed is: the minerals containing materials are loosened with monitors, lifted with slurry pumps and transported with water through channels under gravity. Much experience has been accumulated through a long period of practice. On the basis of summed-up experience, this paper mainly introduces the successful experience in exploitation, designing, and production in large-scale hydraulic mining of placer. In designing and operation, long distance inverted siphon pipes across vast and deep basins have been successfully adopted so as to make the slurry flow under gravity; long distance channels with minimum slope have been used to ease the flow under gravity. In some mines where caved-in caverns contained relatively large placer reserve exist in the karst bedrock, adits and orepasses have been used for transportation in place of the slurry pump lifting; furthermore, some technical measures, such as the treatment of clay agglomerate formed by rolling during transportation and channels built with high abrasiveproof materials have also been taken.

AUTHOR: XU Kailiang [1776 7030 2733]

ORG: None

TITLE: "Facing Mine Production, Stressing Applied Research: A Brief Introduction of Changsha Mining Research Institute"

SOURCE: Beijing YOUSE JINSHU [NONFERROUS METALS] in Chinese No 3, Aug 82 pp 71-79

EXCERPT OF ENGLISH ABSTRACT: Changsha Mining Research Institute (CMRI), one of the technical centers especially for comprehensive research on and development of new methods, technology, equipments, and materials for mining metal deposits in China, is situated at the foot of the Yuelu hills along the western bank of the Xiangjiang River, Changsha, Hunan Province. Founded in 1956, CMRI is one of the scientific research organizations directly under the Ministry of Metallurgical Industry, the People's Republic of China. At present, CMRI has nearly 500 scientific and technical personnel, including over 300 senior engineers and engineers. There are in CMRI 8 research departments, namely, mining methodology, sinking and drifting, loading and hauling, rock mechanics and supporting, drilling tools, blasting technique and materials, rock breaking and drilling machinery, and mining automation and instrumentation, and 10-odd relevant laboratories such as drilling, blasting, core drawing, filling, rock mechanics, grouting, hydraulic, electric drive, rock breaking, diesel exhaust clearing and electric measurement of nonelectric parameters.

[continuation of YOUSE JINSHU No 3, 1982 pp 71-79]

There are also in its possession a research department of technical information, a central laboratory and a subsidiary processing plant for research and trial-manufacture. The scientific research work of CMRI is specially stressed on the efficient methods of underground mining and advanced construction methods of underground projects especially for metallic ore deposits other than coal fields. For over 20 years since its foundation, 1/3 of the achievements made in completed projects of scientific research have been introduced and applied in mine production and construction, among these over 70 items have been ranked as the significant achievements in science and technology by the government. In addition, a lot of products, instruments, and equipments have passed the state appraisal and have been put into series production.

AUTHOR: CHEN Yujiang [7115 3768 3068]

ORG: None

TITLE: "Huanren Mineral Processing Plant"

SOURCE: Beijing YOUSE JINSHU [NONFERROUS METALS] in Chinese No 3, Aug 82 pp 80-84

TEXT OF ENGLISH ABSTRACT: Huanren lead and zinc mineral processing plant lies in the hilly country on the Changbai mountain system in the eastern part of Liaoning Province. This plant went into operation in 1940, but afterwards its operation was interrupted and production was resumed in 1951; its scale gradually enlarged. At present, 4 kinds of concentrates of copper, lead, zinc, and iron are produced. The deposit belongs to the skarns type and in the deposit there are 2 types of ores: lead-zinc ore and copper-iron ore. The ores contain 0.25 percent Cu, 0.28 Pb, 1.16 Zn; in copper-iron ore, iron content is over 20 percent. The plant includes the following sections: crushing and screening, grinding and classification, flotation, magnetic separation, water supply, dewatering, and tailing disposal. The crushing and screening section is the primary closed circuit flowsheet with 3 stages, the crushing product size being -12mm; the grinding and classifying section is one-stage closed-circuit flowsheet, the classifying overflow containing 40 percent solids, in which -200 mesh accounts for 55-65 percent. The technological flowsheet is gradually getting perfect after modification for several times and has got better metallurgical performances. The original designed flowsheet was the preferential flotation

[continuation of YOUSE JINSHU No 3, 1982 pp 80-84]

of lead-zinc ore; in 1977, the copper-lead bulk flotation flowsheet with the iso-floatable feature was designed due to the increase of the copper content in the ores year by year. Copper-lead bulk flotation was carried out first and then copper-lead ore was separated with sulphite: lead roughing concentrate contained over 20 percent Zn and the zinc removing operation had to be included in the flowsheet, the middling being returned to the mill for regrinding and reagent removing. The obtained results were: copper concentrate grade 28.9 percent, copper recovery 85.6, lead concentrate content 63.4, lead recovery 62.7, zinc concentrate grade 54.5, its recovery 90.8. Magnetite in the flotation tailing is recovered by the use of magnetic separation. Iron concentrate with a grade of 66-68 percent can be obtained by fine screening, regrinding, and two-stage cleanings from roughing concentrate. The plant water comes from Hunjiang and stores in high-position water sump. The final tailing contains 25 percent solids (by weight) and it is pumped to the tailing dam with sand pumps, which can hold tailing for 20-25 years.

AUTHOR: LU Baoyu [7627 1405 3768]

ORG: Hulu Island Zinc Plant

TITLE: "Technical Innovation Highly Valued in Huludao Zinc Plant"

SOURCE: Beijing YOUSE JINSHU [NONFERROUS METALS] in Chinese No 3, Aug 82 pp 85-87

TEXT OF ENGLISH ABSTRACT: In last 3 decades, the production in Huludao Zinc Plant has continuously been developing and the economic benefit has constantly been increasing. In this paper, the experiences gained by the plant in these fields are discussed. The plant has succeeded with the following practices: with the connotation in the lead, paying attention to introducing the advanced technology both from abroad and at home, carrying on unceasing technical innovations, and highly regarding the comprehensive utilization of the resources. LU Baoyu graduated from the Baotou Iron and Steel Institute in Inner Mongolia in 1964. Now, he holds the post of Director and Chief Engineer in Huludao Zinc Plant. He has been engaged in planning and management for many years. He has abundant experience in comprehensive planning and technical management in industrial enterprises. He is enthusiastic in the cause of science and technology in the metallurgical field. He is one of the corresponding members of the editorial committee of this journal, a publication of the Chinese Society of Metals. Furthermore, he is a council member and the head of the Pollution Control Academic Group of the Liaoning Society of Metals, member of

[continuation of YOUSE JINSHU No 3, 1982 pp 85-87]

Liaoning Association of Science and Technology. He has authored following technical articles: "Prospects for Zinc Smelting in Vertical Retorts," "Introduction to Zinc Technology in Huludao Zinc Plant," etc.

6248

CSO: 4009/397

END