

A Unique Crosswind Compensated Fire Control Device for Small Arms

Gideon Bar-Tal, Sagie Tsadka, Ehud Azoulay
Soreq NRC, Electro-optics Division
Yavne 81800, Israel

Abstract

In order to increase the lethality of small arms, efforts have been undertaken in two different directions: Improved munitions and advanced Fire Control Systems (FCS).

Our paper describes a unique and novel addition to FCS's – Crosswind compensation.

The adverse effects of crosswind on the ballistics of a projectile are well known, but until now could not be corrected. The crosswind influences the flight of projectiles at short and medium ranges, causing a deflection of the projectile from its aim point and thereby reducing hit probability.

In the case of shooting at small targets from distances of several hundred meters the projectile trajectory is greatly affected by crosswinds. Even moderate crosswinds of less than 10 knots (5m/sec) will cause miss distances of about 25 cm for ranges of 200 meters and more than 1 meter at ranges of 500 meters. This is true for all of the commonly used small arms munitions, such as 5.56 mm (0.2") and 7.62 mm (0.3") caliber bullets. Measurements taken and calculations made in order to quantify the crosswind influence on the projectile's trajectory will be presented in this paper.

The new FCS will perform the combined task of measuring the range to target and the crosswind along the projectile's path. Combining the ballistic parameters of the projectile and the measured information the system processor will calculate a correct aim point.

The operation technique is based on transmitting a low power laser beam along the line of sight to the target, receiving the reflected signal from the target and analyzing its turbulence induced spatio temporal power fluctuations.

Experimental results, which show significant improvement in hit accuracy when shooting at distances of 500 meters under various crosswind conditions, are presented.

19980903 070

DTIC QUALITY INSPECTED 1

AQ I 98-11-2337

Cross Wind Measurement – Principle of Operation

The unit is built around a low power laser that transmits a collimated narrow beam towards the target. The beam is reflected back from the target and detected by the system receiver. The receiver is composed of two horizontally separated detectors (Figure 1). Since the beam passes through the atmospheric turbulence on its way to the target and back to the receiver, it accumulates intensity fluctuations across its phase front due to the diffraction of the refractive-index irregularities that comprise the turbulent medium. According to Taylor's hypothesis, for short time periods, it is true that the refractive-index irregularities drift with the atmospheric wind with no significant change in their shape or spatial distribution (the "frozen" turbulence hypothesis). Therefore, the diffraction pattern of the beam on the target and on the receiver plane also drifts with a velocity that is related to the crosswind component along the optical path. By temporally analyzing the intensity fluctuations in 2 separate positions on the receiver plane, it is possible to compute the crosswind velocity (figure 2).

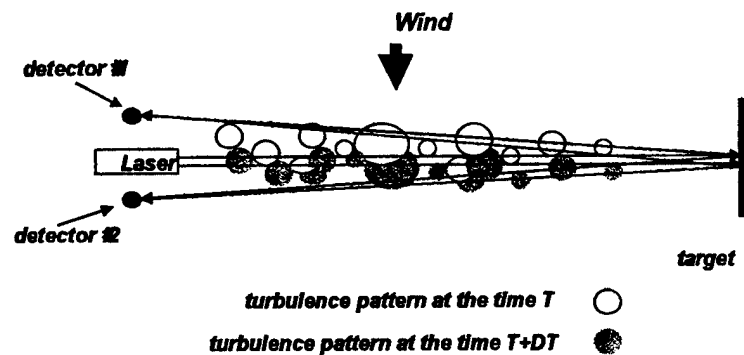

Figure 1 Graphic Presentation of Measuring Technique



detector #1 signal as a function of time



detector #2 signal as a function of time

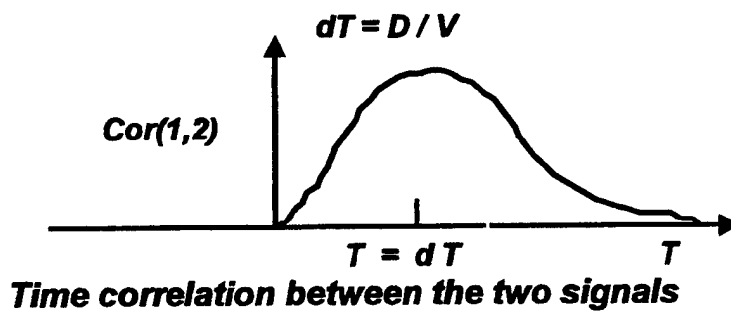

Figure 2 Correlation Function Calculation

Test Results

The crosswind measurement tests were conducted in two stages. The first was designed to demonstrate the accuracy of measurement, and the second to demonstrated the improved performance of the sniper in live firing tests when using the system.

Wind accuracy measurement

The tests were conducted on a 500 meter long target range. Along the measurement path, 3 anemometers were equally spaced which accumulated data over a time period of more than 34 hours. The data was averaged and compared to the output of our wind measurement device. The test results are shown in figure 3 where we can see the good correlation between the two measurement techniques.

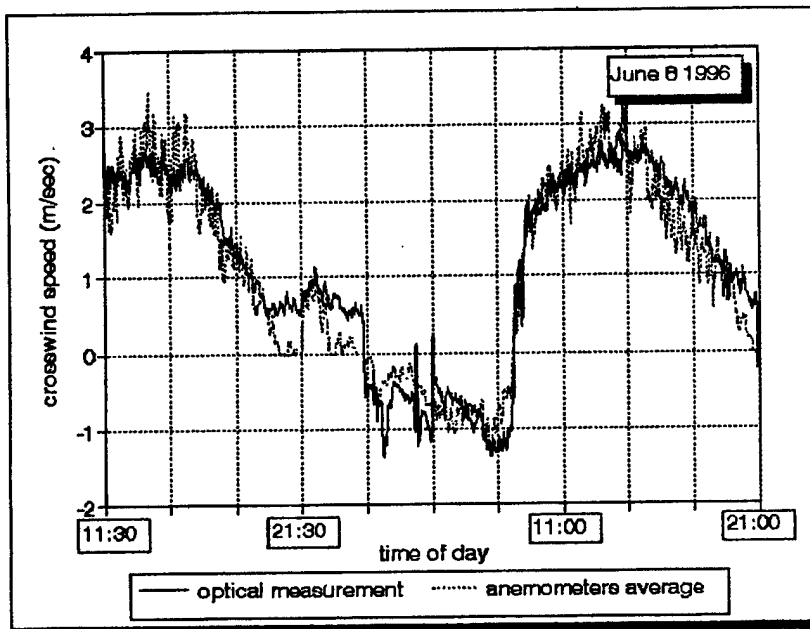

Figure 3 Comparison between Anemometer and Optical measurements

From the results one can see that the wind as measured by individual anemometers are very fluctuative in nature, because they provide results at a point along the path. On the other hand the output as measured by the crosswind sensor is much smoother because it provides results that are an average along the total distance. Another point of interest is that at very low wind speeds (under 0.5 m/sec) the anemometers tend not to give results at all. This is due to the static friction of the device that tends to cause the propeller to stick.

Live fire tests

These tests were conducted along the same 500 meter target range. The sniper shot fired SR86 rifle with a X10 telescope. The rifle was first boresighted at a range of 100 meters and then corrected in elevation for the 500 range. The sniper shot at will at a predefined point on the target. With each shot the crosswind effect on the bullet was calculated and a predicted impact point computed. The test results are shown in figure 4 comparing the true point of impact with the predicted point.

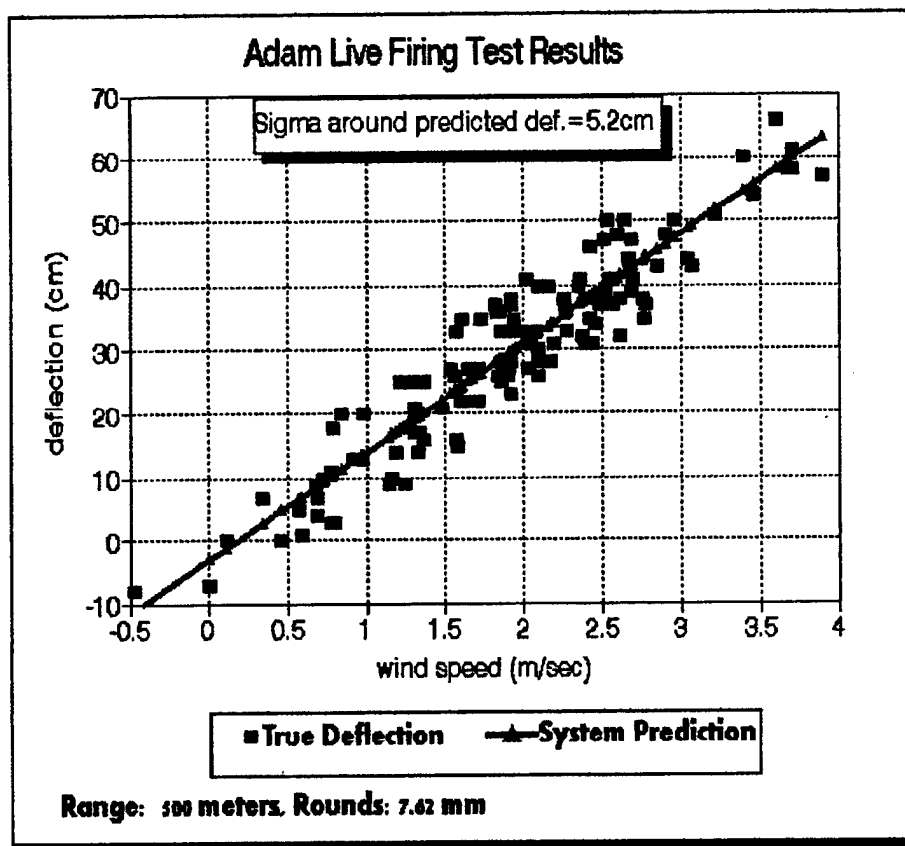

Figure 4 Live fire test results

From the test results in figure 4 one can see the crosswind effect on the horizontal deflection. Even at moderate wind speeds of 3 m/sec the deflection of the bullet is about 50cm. The points of impact are very close together but the horizontal deflection is such that they will miss a human target. With our measurement device we can predict the point of impact (the black line) and show that the true points of impact are distributed about the line. The average true deflection from the prediction point is only 5 cm, which is almost an order of magnitude improvement from the uncorrected horizontal deflection.

Measurement System

The system is an active Electro-optical measurement device built around a low power Nd:YLF laser lasing in the 1.047 μ m range. Two low noise detectors detect the optical signal, returning from the target. The detected signal is amplified and digitized in a pre amplification stage. The digitized signal is sampled by a microprocessor that runs the unique software package that calculates the following parameters:

- ✓ Range to target.
- ✓ Wind speed and direction along the line of fire.
- ✓ Ballistic correction and crosshair correction.

The main system performance characteristics are listed below:

- ✓ Range of operation: 50 - 1000 m
- ✓ Range measurement resolution: 10 m
- ✓ Crosswind Accuracy <1 m/sec
- ✓ Measurement time: <1 sec

Figure 6 is a schematic block diagram of the system, and figure 7 shows the Demonstration model mounted on a Pan and Tilt unit.

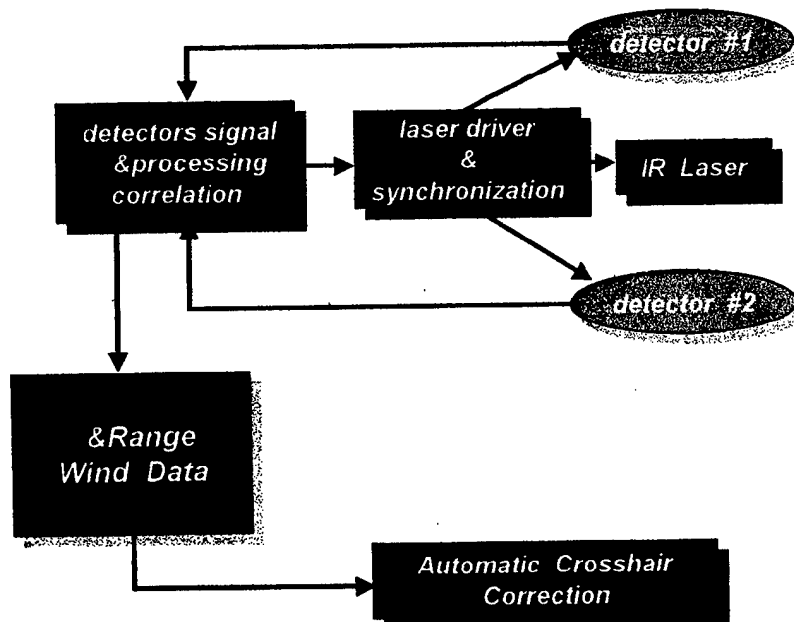

Figure 6 Schematic Bloc Diagram

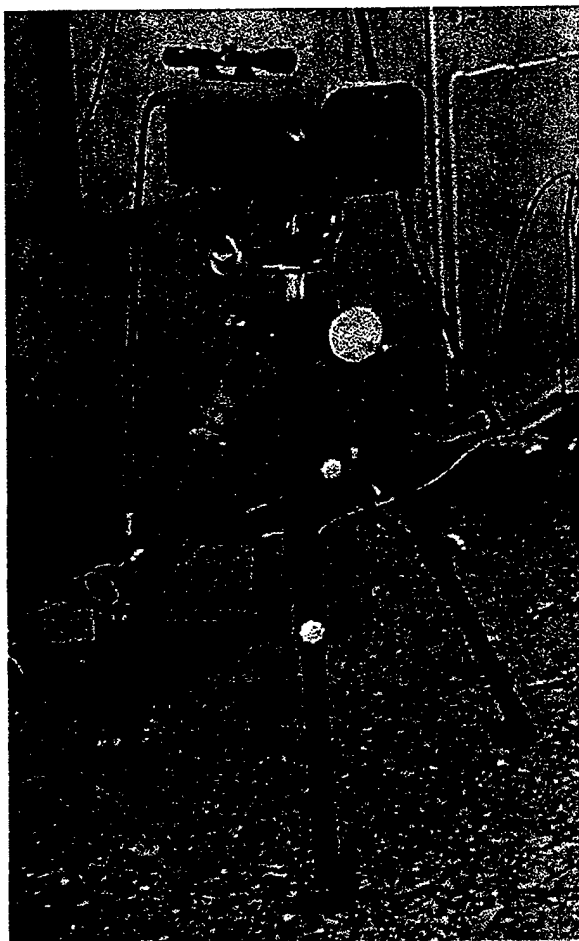

Figure 7 Crosswind Demonstration model

Future Developments and Applications

The technology advances over the last years in both compact high efficiency lasers and electronics has made it feasible today to add new features to Fire Control Systems. FC systems are finding their place in new small arms such as the OICW, OCSW and new sniper weapons (OSW), as well as in larger devices such as unguided rockets and tank guns.

All projectiles tend to either drift with the crosswind when decelerating or fly into the wind when accelerating. System analysis performed on different weapons and munitions show that the effect of the wind on the accuracy is substantial. New FC systems have as yet not incorporated the capability to measure crosswind over the total line of sight, because the technology up to now has not been well developed and proven. The demonstration model along with our unique patented hardware and software package has made it possible today to add crosswind measurements for improved performance.

INTERNET DOCUMENT INFORMATION FORM

A . Report Title: A Unique Crosswind Compensated Fire Control Device for Small Arms

B. DATE Report Downloaded From the Internet 8/31/98

C. Report's Point of Contact: (Name, Organization, Address, Office Symbol, & Ph #): Gideon Bar-Tal
Soreq NRC, Electro-Optics Dive
Yavne 81800, Israel

D. Currently Applicable Classification Level: Unclassified

E. Distribution Statement A: Approved for Public Release

F. The foregoing information was compiled and provided by:
DTIC-OCA, Initials: UM Preparation Date: 8/31/98

The foregoing information should exactly correspond to the Title, Report Number, and the Date on the accompanying report document. If there are mismatches, or other questions, contact the above OCA Representative for resolution.