

LOAN DOCUMENT

PHOTOGRAPH THIS SHEET

①

INVENTORY

DTIC ACCESSION NUMBER

LEVEL

AL/EG-TR-1997-0043
DOCUMENT IDENTIFICATION
14 Feb 98

DISTRIBUTION STATEMENT A

Approved for public release
Distribution Unlimited

DISTRIBUTION STATEMENT

ACCESSION FOR	
NTIS	GRAM <input checked="" type="checkbox"/>
DTIC	TRAC <input type="checkbox"/>
UNANNOUNCED	<input type="checkbox"/>
JUSTIFICATION	<input type="checkbox"/>
BY	
DISTRIBUTION/	
AVAILABILITY CODES	
DISTRIBUTION	AVAILABILITY AND/OR SPECIAL
A-1	

DISTRIBUTION STAMP

DTIC QUALITY CONTROL

19980904 007

DATE RECEIVED IN DTIC

DATE ACCESSIONED

DATE RETURNED

REGISTERED OR CERTIFIED NUMBER

H
A
N
D
L
E

W
I
T
H

C
A
R
E

PHOTOGRAPH THIS SHEET AND RETURN TO DTIC-FDAC

AL/EQ-TR-1997-0043

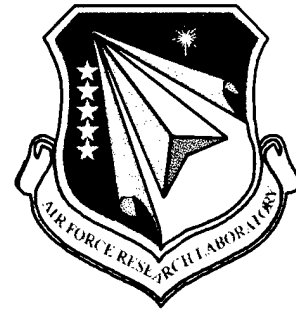

VOC CAPTURE BY ORGANOPHILIC PILLARED MONTMORILLONITES

BRET H. HOWARD
NOXSO CORPORATION
2414 LYTTLE ROAD
BETHEL PARK PA 15102

14 FEBRUARY 1998

FINAL REPORT: APRIL 1996 – DECEMBER 1996

Approved for public release; distribution unlimited

AIR FORCE RESEARCH LABORATORY
MATERIALS & MANUFACTURING DIRECTORATE
AIRBASE & ENVIRONMENTAL TECHNOLOGY DIVISION
TYNDALL AFB FL 32403-5323

NOTICES

This report was prepared as an account of work sponsored by an agency of the United States Government. Neither the United States Government nor any agency thereof, nor any employees, nor their contractors, subcontractors, or their employees make any warranty, express or implied, or assume any legal liability or responsibility for the accuracy, completeness, or usefulness of any privately owned rights. References herein to any specific commercial process or service by trade name, trademark, manufacturer, or otherwise does not necessarily constitute or imply its endorsement, recommendation, or favoring by the United States Government or any agency, contractor, or subcontractor thereof. The views and opinions of the authors expressed herein do not necessarily state or reflect those of the United States Government or of any agency, contractor, or subcontractor thereof.

When government drawings, specifications, or other data are used for any purpose other than in connection with a definitely government-related procurement, United States Government incurs no responsibility or obligations, whatsoever. The fact that the Government may have formulated or in any way supplied the said drawings, specifications or other data is not to be regarded by implication, or otherwise in any other manner construed, as licensing the holder or any other person or corporation, or as conveying any rights or permission to manufacture, use or sell any patented invention that may in any way be related thereto.

This is an SBIR Phase I report. The contractor has given permission for public release. This technical report has been reviewed by the Public Affairs Office [PA] and is releasable to the National Technical Information Service, where it will be available to the general public, including foreign nations.

This report has been reviewed and is approved for publication.



JOSEPH D. WANDER, PhD
Project Manager



CHRISTINE WAGENER-HULME, Lt Col, USAF
Chief, Environmental Technology
Development Branch

If your address has changed, if you wish to be removed from our distribution list, or if the addressee is no longer employed by your organization, please notify AFRL/MLQP, Tyndall AFB, Florida 32403-5323, or andrew.poulis@ccmail.af.mil.

Do not return copies of this report unless contractual obligations or notice on a specific document requires its return.

REPORT DOCUMENTATION PAGE			Form Approved OMB No. 0704-0188	
Public reporting burden for this collection of information is estimated to average 1 hour per response, including the time for reviewing instructions, searching existing data sources, gathering and maintaining the data needed, and completing and reviewing the collection of information. Send comments regarding this burden estimate or any other aspect of this collection of information, including suggestions for reducing this burden, to Washington Headquarters Services, Directorate for Information Operations and Reports, 1215 Jefferson Davis Highway, Suite 1204, Arlington, VA 22202-4302, and to the Office of Management and Budget, Paperwork Reduction Project (0704-0188), Washington, DC 20503.				
1. AGENCY USE ONLY (Leave blank)	2. REPORT DATE 980214	3. REPORT TYPE AND DATES COVERED Final Report 9604-9612		
4. TITLE AND SUBTITLE VOC Capture by Organophilic Pillared Montmorillonites			5. FUNDING NUMBERS JON: 3005ES6B Contract No. F41624-96-C-0007 PE: 65502F	
6. AUTHOR(S) Howard, Bret H.				
7. PERFORMING ORGANIZATION NAME(S) AND ADDRESS(ES) NOXSO Corporation 2414 Lytle Road Bethel Park, PA 15102			8. PERFORMING ORGANIZATION REPORT NUMBER	
9. SPONSORING/MONITORING AGENCY NAME(S) AND ADDRESS(ES) Armstrong Laboratory, Environics Directorate [AL/EQ] 139 Barnes Drive, Suite 2 Tyndall AFB, FL 32403-5323			10. SPONSORING/MONITORING AGENCY REPORT NUMBER AL/EQ-TR-1997-0043	
11. SUPPLEMENTARY NOTES Technical Monitor: Dr. Joe Wander; AL/EQM; COMM (850) 283-6240, DSN 523-6240				
12a. DISTRIBUTION AVAILABILITY STATEMENT Approved for Public Release. Distribution unlimited			12b. DISTRIBUTION CODE A	
13. ABSTRACT (Maximum 200 words) Volatile organic compounds [VOCs] are used widely in industrial applications. Release of VOCs into the atmosphere has resulted in detrimental environmental effects, including elevated ozone levels in the troposphere. The objective of this project was to investigate organophilic pillared montmorillonites [OPMs] as sorbents for VOC control. Other sorbents were also examined, including activated chars. In most determinations, MEK was used to test the capacity of sorbents to adsorb VOCs. OPMs were prepared by exchanging alkylammonium cations between the montmorillonite layers, resulting in increased separation between layers; however, the volume between the clay layers was found to be inaccessible for VOC sorption. Fifteenfold enhancement of the capacity of the montmorillonite-based sorbents to adsorb MEK was achieved by introducing inorganic pillaring species to increase clay-layer separation. Montmorillonite-based sorbents have potential to be good VOC sorbents, but they will require further development. Activated chars produced directly from bituminous coal through a proprietary process by the Illinois State Geological Survey were also tested, and several were found to have high capacity for MEK. One char was subjected to more-thorough testing, including 10 sorption/regeneration cycles, and found to retain high activity. Activated chars were found to have characteristics allowing them to be used in similar VOC control applications as activated carbons.				
14. SUBJECT TERMS VOC, air pollution control, ozone, montmorillonite, clay, adsorption			15. NUMBER OF PAGES 68	
			16. PRICE CODE	
17. SECURITY CLASSIFICATION OF REPORT UNCLASSIFIED	18. SECURITY CLASSIFICATION OF THIS PAGE UNCLASSIFIED	19. SECURITY CLASSIFICATION OF ABSTRACT UNCLASSIFIED	20. LIMITATION OF ABSTRACT UL	

PREFACE

This is the final report for the Phase I Small Business Innovation Research (SBIR) project funded by the U. S. Air Force Armstrong Laboratory, Environics Directorate, Environmental Compliance Division (AL/EQS), 139 Barnes Avenue, Suite 2, Tyndall Air Force Base FL 32403-5323 under contract F41624-96-C-0007. This report was prepared by NOXSO Corporation, 2414 Lytle Road, Bethel Park PA 15102.

This report describes the results obtained during the study of organophilic pillared montmorillonites for the control of volatile organic compounds (VOCs), specifically VOCs produced during stripping and repainting operations carried out by the U. S. Air Force. The study was expanded to include other montmorillonite-based sorbents as well as activated chars.

This work was performed between April 1996 and December 1996 at NOXSO's Clairton Research Center, 527 St. Clair Avenue, Clairton, PA 15025. The AL/EQS project officer was Dr. Joseph D. Wander.

EXECUTIVE SUMMARY

VOC CAPTURE BY ORGANOPHILIC PILLARED MONTMORILLONITES

A. OBJECTIVE:

The objective of this project was to prepare organophilic pillared montmorillonites (OPMs) and test them for their ability to function as sorbents for use in volatile organic compound (VOC) control. Montmorillonite is a natural clay mineral having characteristics which enable modification of its structure. One of the primary sources of VOCs targeted by this project was VOCs released by Air Force paint stripping and application operations. Investigation of sorbent materials was expanded to include other modified montmorillonites as well as activated chars.

B. BACKGROUND:

Volatile organic compounds (VOCs) effectively include all organic compounds with significant vapor pressure. VOC emissions are of concern due to several negative effects on the environment including contribution to photochemical smog formation and depletion of the ozone layer. Industrial processes are the major sources of VOC emissions (about 46 percent). Since 1990, the U.S. Environmental Protection Agency (EPA) has conducted the Toxic Release Inventory (TRI) program which is a database containing comprehensive chemical discharge information. It was reported that more than 2900 individual metal fabrication facilities produced a total discharge of 195 million pounds of 106 reportable chemicals throughout the United States. Among them, there are 22 compounds discharged at a rate of more than 1 million pounds per year each which account for about 94 percent of the total chemicals released. Of these 22 chemicals, 13 are solvents with a total release of 137 million pounds. Six industrial solvents are considered to be VOCs as well as hazardous air pollutants (HAPs): trichloroethylene (TCE), acetone, methyl ethyl ketone (MEK), methyl isobutyl ketone (MIBK), toluene, and xylene. These six solvents have a total release of 62.5 million pounds per year. Several laws have addressed control of VOC emissions including the Montreal Protocol on substances that deplete the ozone layer; the Clean Air Act Amendments (CAAA) of 1990; the EPA Industrial Toxics Program (voluntary); the Superfund Amendment and Reauthorization Act; and the Hazardous and Solid Waste Amendments to the Resource Conservation and Recovery Act (RCRA). Title III of the CAAA requires regulation of 189 chemicals which are referred to as HAPs. Those VOCs defined as HAPs are becoming strictly regulated as to their use and emissions.

A variety of industrial processes utilize solvents and contribute to VOC emissions. Solvents are used as cleaning agents in metal-finishing, metal manufacturing (automotive, aerospace, rail, ship, appliance, and tooling), industrial maintenance application, precision cleaning, and electronics manufacturing. Paint application is also an important VOC source and is presently of concern to the Air Force.

The key technologies for controlling VOCs are oxidation (thermal or catalytic), adsorption, membranes, condensation, and absorption. All of these technologies have some disadvantages. It is apparent that there is a need to develop other more efficient and cost effective technologies for VOC control. The proposed technology is to adsorb VOCs from a dilute air stream at room temperature and pressure using a modified low-cost, natural material in a simple and safe system. The concentrated VOCs can then be released in a controlled manner for final destruction.

C. SCOPE:

During this study a variety of montmorillonite-based sorbents were prepared and characterized. Their potential for VOC control was determined by laboratory scale testing of their VOC removal capability using methyl ethyl ketone (MEK) as a model VOC. Characterization results and MEK removal activities were used to guide development of the montmorillonite-based sorbents. The laboratory results obtained for the montmorillonite-based sorbents suggested that they presented potential in the area of VOC control but required further development beyond what could be done during this project. Therefore, another potential VOC sorbent material was identified for study. This material, activated char, was tested in the same manner as the montmorillonite-based sorbents and found to have good potential as a VOC sorbent. It was, therefore, subjected to a wider range of tests including other model VOCs and multiple cycles of adsorption and regeneration. Activated char was found to have both positive and negative characteristics. Based on the laboratory results, both sorbent types were evaluated for their commercial potential.

D. METHODOLOGY:

Preparation of all montmorillonite-based sorbents was carried out in the laboratory of NOXSO Corp. Activated chars were prepared by Illinois State Geological Survey (ISGS) through a proprietary process. Most characterization and all VOC control testing was also conducted at NOXSO's laboratory. Sorbents were typically characterized by surface area measurement using the BET method and powder x-ray diffraction for determination of clay-layer separation and phases present. A laboratory-scale reactor was used for VOC sorption evaluations utilizing a gas chromatograph for VOC quantification. The results obtained using these methods were used to guide sorbent development and evaluation.

E. TEST DESCRIPTION:

The tests used to evaluate the potential of the sorbents for VOC control consisted of preparation of a VOC-spiked gas flow that was passed through the reactor at a predetermined flow rate. The gas flow could also be humidified when required. A known amount of sorbent was placed in the reactor as a fixed bed. A gas chromatograph (GC) was used to measure the VOC concentration at the reactor inlet and outlet. The VOC concentration exiting the sorbent bed versus time was used to determine the sorbent's capacity for the model VOC and allow

comparison of the sorbents tested during the project. Results were compared to typical commercial sorbents.

F. RESULTS:

Montmorillonite was successfully pillared with alkylammonium cations resulting in an increase in the clay-layer separation; however, the volume between the clay layers was inaccessible for VOC sorption as shown by the low surface area and low MEK capacity. Improvement of the montmorillonite-based sorbents was attempted by increasing the clay layer separation using inorganic pillaring species both with and without subsequent organic modification. Inorganic modification methods used for montmorillonite sorbents included montmorillonite modified by exchange with colloidal alumina both with and without alkylammonium addition, montmorillonite pillared by Keggin ions, and montmorillonite modified by silica gel. Significant improvements were obtained through these steps resulting in a capacity improvement of over 15 times for MEK. However, the montmorillonite-based sorbents still had an MEK capacity that was only about ten percent of that of a commercial activated carbon used for VOC control.

Activated chars obtained from ISGS were tested for their VOC removal potential using MEK as the model VOC. Several samples were found to have high MEK capacity under the experimental conditions approaching commercial activated carbon. Of these, one was subjected to more thorough testing. All of these tests were executed using humid atmospheres. A sample was subjected to 10 sorption/regeneration cycles using MEK and found to retain high activity. It was also subjected to two sorption/regeneration cycles for both trichloroethylene and toluene and found to perform well for both of these VOCs. A drawback for activated chars, however, is their high mineral impurity content. The sample tested contained over 25 % ash.

G. CONCLUSIONS:

Montmorillonite-based sorbents were found to have potential as VOC sorbents but require further development to increase their VOC capacity and lower their cost. Activated chars were found to have characteristics that would allow them to be used in similar VOC control applications as activated carbons. Experimental results indicated that activated chars could be considered to be low-purity activated carbon.

H. RECOMMENDATIONS:

Development of montmorillonite-based sorbents should be continued. Better and less expensive pillaring species and procedures should be investigated to increase VOC capacity and lower production price. Activated chars have good potential to replace activated carbon in some VOC control applications based on their good performance and low estimated cost of about \$200 to \$1500 per ton depending on the specific preparation steps used. Their high mineral impurity content, however, is likely to make them unsuitable for applications involving halogenated VOCs

because of the potential for production of corrosive byproducts during regeneration which could lead to equipment degradation. This potential problem should be investigated through laboratory testing.

TABLE OF CONTENTS

Section	Title	Page
I	INTRODUCTION.....	1
	A. OBJECTIVE.....	1
	B. BACKGROUND.....	1
	1. Outline of the VOC Problem.....	1
	2. Technology Proposed to Address the VOC Problem.....	2
	C. PHASE I RESEARCH APPROACH.....	5
II	EXPERIMENTAL PROCEDURE.....	7
	A. VOC SORPTION APPARATUS AND EXPERIMENTAL CONDITIONS.....	7
	1. VOC Sorption Reactor.....	7
	2. Model VOCs.....	9
	3. Typical Sorption and Regeneration Conditions and Procedure.....	10
	B. SORBENT PREPARATION.....	11
	1. Montmorillonite-based Sorbents.....	11
	a. BH58-1 - Montmorillonite pillared with TNBA cations....	12
	b. BH58-2 - Montmorillonite pillared with TDTA cations....	12
	c. BH58-8 - Montmorillonite pillared with TNBA cations....	13
	d. BH58-87 - Montmorillonite pillared with 0.5 X C.E.C. of TNBA.....	13
	e. BH58-24 - Montmorillonite with colloidal alumina and TNBA.....	13
	f. BH58-25 - Montmorillonite with colloidal alumina.....	14
	g. BH58-32 - Montmorillonite pillared with Al ₁₃ Keggin ions.....	14
	h. BH58-37 - Pelletized SWy-2 montmorillonite.....	14
	i. BH58-69 - Montmorillonite-silica gel composite.....	14
	2. Activated char sorbents.....	15
	3. Commercial sorbents.....	15
	a. Activated alumina.....	15
	b. Activated carbon.....	15
	C. SORBENT CHARACTERIZATION.....	15
	1. Surface area measurements.....	16
	2. Powder X-ray diffraction.....	16
	3. Low-temperature oxidation.....	16

TABLE OF CONTENTS

Section	Title	Page
III	RESULTS AND DISCUSSION.....	17
A.	RESULTS FOR MONTMORILLONITE-BASED SORBENTS.....	17
1.	Montmorillonite pillared with alkylammonium cations.....	17
a.	OPM synthesis test results.....	17
b.	BH58-8 - Montmorillonite pillared with TNBA cations....	18
c.	BH58-87 - Montmorillonite pillared with 0.5 x CEC of TNBA.....	18
d.	BH58-37 - Pelletized SWy-2 montmorillonite.....	21
2.	VOC capacity tests of TNBA pillared montmorillonites.....	21
3.	Montmorillonite modified by inorganic materials.....	23
a.	Montmorillonite modified with colloidal alumina.....	24
b.	Montmorillonite pillared with Al ₁₃ Keggin ions.....	25
c.	Montmorillonite/silica gel composite.....	25
4.	VOC capacity tests of montmorillonite modified with inorganic materials.....	26
a.	BH58-24 and BH58-25.....	26
b.	BH58-32.....	28
5.	VOC capacity tests under moist conditions.....	28
a.	BH58-25 and BH58-69.....	28
b.	Activated carbon.....	32
B.	RESULTS FOR ACTIVATED CHAR SORBENTS.....	34
1.	Activated char Pilot 3.....	34
2.	Activated char for VOC control.....	36
a.	MEK sorption tests for activated chars C, E, F, G, and Pilot 3 #2.....	36
3.	Extensive testing of char G.....	39
a.	Multiple cycle test using MEK.....	39
b.	Char G with other VOCs.....	42
c.	Ash content and composition of char G.....	44

TABLE OF CONTENTS

		Page
Section	Title	
IV	CONCLUSIONS AND RECOMENDATIONS.....	46
	A. MONTMORILLONITE-BASED SORBENTS.....	46
	B. ACTIVATED CHAR.....	47
	REFERENCES.....	48

LIST OF FIGURES

Figure		Page
1	Schematic diagram of OPM preparation.....	4
2	Schematic diagram of VOC control system.....	5
3	Diagram of VOC sorption reactor.....	8
4	Comparison of basal peak position and shape for BH58-8 and unexchanged SWy-2.....	19
5	Diagram of proposed result of TNBA exchange reaction.....	20
6	Comparison of MEK sorption behavior of BH58-8, BH58-37, and activated alumina under dry conditions.....	22
7	Comparison of MEK sorption behavior of BH58-8, -37, -24, -25, and -32 versus HPX activated alumina under dry conditions.....	27
8	Comparison of MEK sorption curves of BH58-25 and BH58-69 to activated alumina under moist conditions.....	30
9	Comparison of MEK sorption capacity of activated alumina under dry and moist conditions.....	31
10	Comparison of MEK sorption curve of activated carbon to BH58-69 and activated alumina under moist conditions.....	33
11	Comparison of MEK sorption curve of Pilot 3 char to activated carbon under moist conditions.....	35
12	MEK sorbtion curves of activated chars compared to activated carbon under moist conditions.....	37
13	Regeneration curve for char G cycle 1 showing MEK concentration and reactor temperature versus time.....	41
14	Comparison of MEK, TCE, and toluene sorption characteristics for char G.....	43

LIST OF TABLES

Table		Page
1	Comparison of VOC control technologies.....	3
2	Characteristics of model VOCs.....	9
3	Characteristics of montmorillonite SWy-1.....	11
4	Summary of characteristics of alkylammonium pillared montmorillonites.....	17
5	Summary of MEK sorption characteristics of alkylammonium exchanged montmorillonites versus activated alumina.....	23
6	Summary of characteristics of modified montmorillonite sorbents prepared for this study.....	24
7	Summary of MEK sorption characteristics of inorganically modified montmorillonites.....	26
8	MEK sorption characteristics for BH58-25, BH58-69, and activated alumina under dry and moist conditions.....	29
9	Comparison of MEK sorption behavior of activated carbon to BH58-69 and activated alumina.....	32
10	MEK removal results for Pilot 3 activated char and commercial activated carbon under moist conditions.....	34
11	Activated chars obtained for VOC control testing.....	36
12	Comparison of MEK removal results for activated chars and commercial activated carbon under moist conditions.....	38
13	MEK capacities for activated chars and commercial activated carbon after correction for surface-area differences.....	39
14	Summary of 10-cycle experiment for char G.....	40

Table		Page
15	Comparison of the weight of MEK adsorbed versus the quantity obtained on regeneration derived from GC data.....	42
16	Results of VOC removal by char G.....	42

SECTION I

INTRODUCTION

A. OBJECTIVE

The objective of this project was to examine the feasibility of using organophilic pillared montmorillonite sorbents for the removal of volatile organic compounds (VOCs) from gas flows at ambient temperature and pressure. One of the primary sources of VOCs targeted by this project was VOCs released by paint stripping and application. The project was expanded to include several other new sorbent materials.

B. BACKGROUND

1. Outline of the VOC problem

Volatile organic compounds (VOCs) effectively include all organic compounds with significant vapor pressure. VOCs have a very wide range of reactivity. The extremely reactive VOCs, such as butene or ethylene, will combine with nitrogen oxides under sunlight to form photochemical oxidants including ozone and peroxyacetyl nitrate¹. These oxidants may cause irritation to the eyes, nose, and throat, as well as damage to plant life and building materials. Ozone can also attack rubber, textiles, paints, and other materials. On the other hand, chlorofluorocarbons (CFCs) are extremely stable, which enables them to persist in the atmosphere. CFCs migrate to the stratosphere, catalyze the destruction of ozone, and allow more ultraviolet radiation to reach the earth's surface, which can cause skin cancer. VOCs include hydrocarbons, aldehydes, ketones, chlorinated solvents, refrigerants, *etc.*¹ Industrial processes are the major sources of VOC emissions (about 46 percent).¹

Since 1990, the U.S. Environmental Protection Agency (EPA) has conducted the Toxic Release Inventory (TRI) program, which is a database containing comprehensive chemical discharge information. Some of the discharges are at ground level although over 40 percent of the TRI pollutants are discharged from stacks. It was reported that more than 2900 individual metal fabrication facilities produced a total discharge of 195 million pounds of 106 reportable chemicals throughout the United States. Among them, there are 22 compounds discharged at a rate of more than 1 million pounds per year each which account for about 94 percent of the total chemicals released. Of these 22 chemicals, 13 are solvents with a total release of 137 million pounds. Six industrial solvents are considered to be VOCs as well as hazardous air pollutants (HAPs): trichloroethylene (TCE), acetone, methyl ethyl ketone (MEK), methyl isobutyl ketone (MIBK), toluene, and xylene. A total of 62.5 million pounds per year is released of these six solvents.

Paint application is a finishing step in the manufacturing process that imparts decoration and protection against corrosion and oxidation to finished items¹. With its low equipment costs

and ease of operation, the solvent spray methods of paint application are used most often. Solvents are used to disperse pigments and binders to aid in their application to surfaces as well as to remove paint from surfaces. Currently, VOCs are emitted to the ambient air in the work area when the paint is being applied and is curing. Paint application transfer efficiencies are typically poor (less than 50 percent). The resulting paint overspray creates environmental, health, and safety problems for industry. These VOCs must be collected and recycled as byproducts or disposed of as hazardous waste ¹.

Solvents are also used as cleaning agents in metal finishing, metal manufacturing (automotive, aerospace, rail, ship, appliance, and tooling), industrial maintenance application, precision cleaning, and electronics manufacturing ¹.

Several official actions have addressed control of VOC emissions including the Montreal Protocol on substances that deplete the ozone layer; the Clean Air Act Amendments (CAAA) of 1990; the EPA Industrial Toxics Program (voluntary); the Superfund Amendment and Reauthorization Act (SARA); and the Hazardous and Solid Waste Amendments to the Resource Conservation and Recovery Act (RCRA). Title III of the CAAA requires regulation of 189 chemicals which are referred to as HAPs. Those VOCs defined as HAPs are becoming strictly regulated as to their use and emissions.

The key technologies for controlling VOCs are oxidation (thermal or catalytic), biotreatment, adsorption, membranes, condensation, and absorption. ¹ These control technologies are compared by Freeman ¹ as shown in Table 1. As can be seen, all the current VOC control technologies have certain disadvantages. It is apparent that there is a need to develop other more-efficient and cost-effective technologies for VOC control. The proposed technology is to adsorb VOCs from a dilute air stream at room temperature and pressure using a modified low-cost, natural material in a simple and safe system. The concentrated VOCs can then be released in a controlled manner for recycle or final destruction.

2. Technology Proposed to Address the VOC Problem

NOXSO Corporation proposed the application of a well-known material, montmorillonite, pillared with organophilic species for the capture of VOCs through an adsorption/regeneration approach. The organically treated montmorillonites have been proven to have strong adsorption capability for several VOCs, including toluene and xylene.^{2,3} Pillared montmorillonites have been known for many years and are frequently discussed in the literature, however, this is a new application for these materials. Montmorillonite, a commonly occurring type of clay, possesses a negative charge in the aluminosilicate layer due to substitutions in the crystal lattice. This negative layer charge is countered by cations between the layers, usually Na⁺ and/or Ca²⁺. Since the layers of the clay are weakly held together by electrostatic charges, they can be separated in water. This increased layer separation allows exchange of the interlayer cations with other cations in solution. Nearly any water-soluble cationic species can be placed between the clay layers by this exchange process. Selection of the appropriate cationic species can result in a permanent

Table 1. Comparison of VOC control technologies.

Technology	Eff.	Advantages	Disadvantages
Catalytic Incineration	?	High destruction efficiency. Essentially less expensive than thermal oxidation.	No recovery of organics. Potential catalyst poisoning. High capital cost.
Adsorption	50-95%	Effective for solvent recovery. Low capital cost.	No selectivity. Moisture constraints with activated carbon.
Membranes	90-99%	Effective for recovery of lower volatility compounds. No need for regeneration.	Requires careful pretreatment to achieve long life. Lower selectivity.
Condensation	50-90%	Effective for product recovery.	Limited applicability; used for pretreatment.
Absorption	>90%	Effective for product recovery, especially for organic vapors.	Limited applicability.

layer separation allowing access between the clay layers and, also, tailoring of the chemical characteristics of the pillared montmorillonite. Organically pillared clays have been shown to have net volumes available for sorption comparable to zeolites.^{2,3} Also, these materials have a strong affinity for organic sorbate species due to the nonpolar hydrocarbon portion of the pillaring alkylammonium cations.

The method of synthesizing the proposed organically pillared montmorillonite (OPM) is well established. The natural montmorillonite, preferably the sodium form, is dispersed in water, followed by the addition of a solution of the exchanging cation. The mixture is allowed to equilibrate for a period of time. Potential candidates for this cationic exchange are tetraalkylammonium salts such as tetra-*n*-butylammonium bromide, though there are other possibilities. Selection is dictated by the layer separation achieved, chemical and thermal stability, and cost. The product is then separated from the solution, washed, and dried. The amount of exchange cation required to produce the pillared clay is controlled by the layer charge. This quantity is usually expressed as the cation exchange capacity (CEC) of the clay. The CEC is typically about 100 meq/100 g clay or about one mole of a singly charged cationic species per kilogram of clay. The OPM would be pelletized for ease of use. **Figure 1** outlines the technique used for OPM preparation.

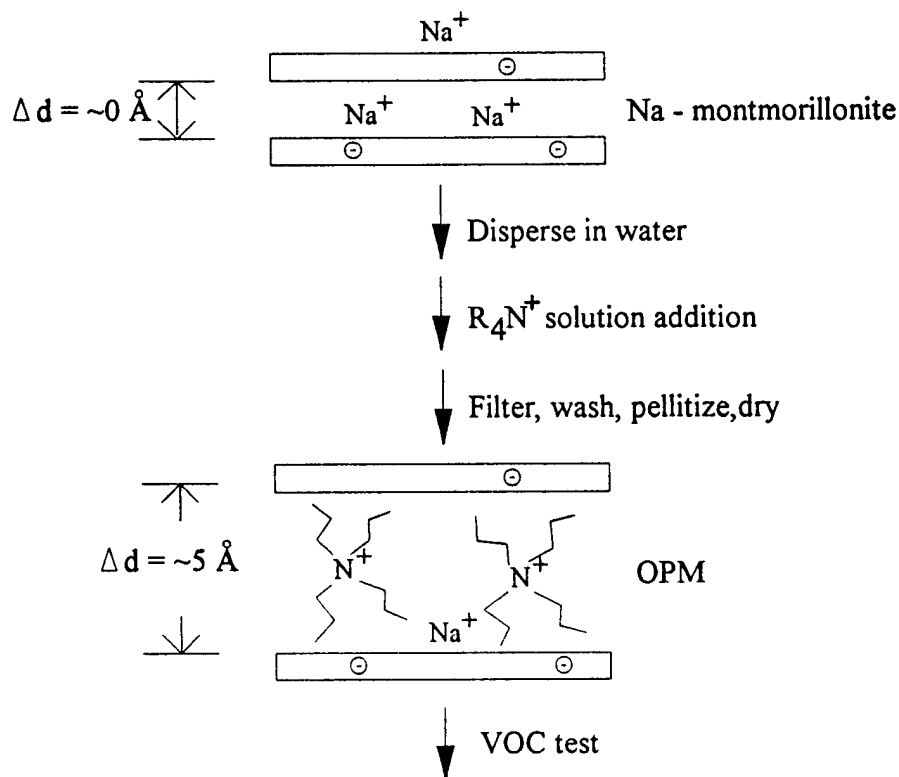

Figure 1. Schematic diagram of OPM preparation.

The OPM would most likely be used in a fixed bed type system to absorb VOCs from a polluted air flow source. When the system can no longer achieve the desired removal efficiency, or when the overall removal capacity is reached, the sorbent is regenerated. Regeneration is carried out by a low temperature heating treatment in a low flow air stream, or under vacuum. The VOCs released during the regeneration procedure are then destroyed in a small incinerator or biological filter. Alternatively, if the sorbed VOCs are especially toxic, it may be more desirable to incinerate the spent sorbent itself which will destroy the trapped VOCs and leave a clean waste aluminosilicate for disposal. Figure 2 demonstrates the schematic diagram of the proposed process.

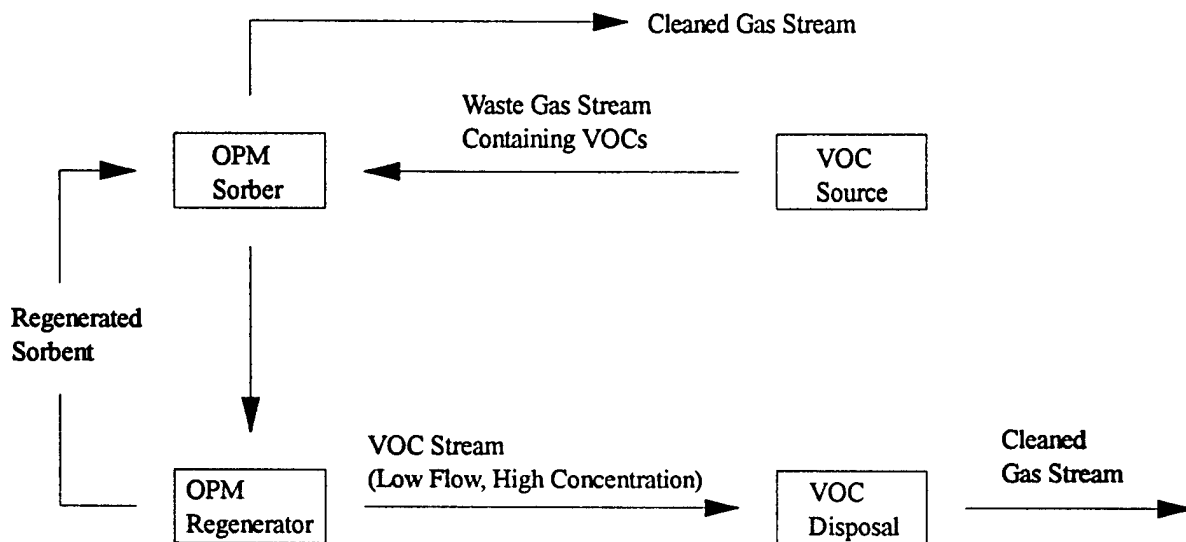

Figure 2. Schematic diagram of VOC control system.

C. PHASE I RESEARCH APPROACH

The research approach used for Phase I of this project was to prepare sorbent materials and evaluate them based on their VOC sorption behavior and other characteristics such as surface area. The experimental results were used to guide the development and improvement of the montmorillonite-based sorbents. The results obtained for the sorbents developed in this project were compared to those of several commercially available sorbent materials under the same experimental conditions. The goal was to improve the montmorillonite-based sorbents to the extent that they would be competitive with commercially available VOC sorbents. Guidelines for successful development were the achievement of a VOC sorption capacity similar to that of sorbents presently on the market, regenerability of the sorbent, low moisture sensitivity and low cost.

During the initial period of this project, methods for the preparation of the organically pillared montmorillonites were tested. Testing of the preparation procedure was initially done using small scale syntheses so that procedural problems could be identified and corrected.

Following development of a successful synthesis procedure, the sorbent preparation was scaled up enough to provide sorbent for testing. Also, a simple method of pelletizing the montmorillonite-based sorbents by syringe extrusion was developed. Pelletizing of the sorbent was necessary so that excessive back-pressure, expected when using powdered sorbents in a downflow fixed bed at high flow rates, could be avoided.

Also, during the initial period of the project, the VOC sorption reactor was constructed and tested. The results obtained as sorbents were prepared and tested were used to guide subsequent montmorillonite-based sorbent synthesis. This approach resulted in significant changes in the originally proposed alkylammonium-pillared montmorillonite sorbents and also to great improvements in the VOC capacity of the montmorillonite-based sorbents.

Activated chars were also investigated as VOC sorbents. These materials were found to have very good characteristics for use in the control of VOCs. Under the experimental conditions used, their capacities were found to approach that of activated carbon produced specifically for VOC control. Activated chars were studied in more detail because of their apparent potential.

SECTION II

EXPERIMENTAL PROCEDURE

The following sections describe the experimental procedures used for Phase I of this project. The experimental apparatus is described followed by the procedures used for the preparation of the VOC sorbents. Sorbent characterization methods are also given.

A. VOC SORPTION APPARATUS AND EXPERIMENTAL CONDITIONS

1. VOC Sorption Reactor

The VOC sorption apparatus consisted of three primary parts: the gas preparation system the VOC sorption reactor, and the VOC analysis system. A schematic of the apparatus is shown in **Figure 3**.

The gas preparation system was used to control the gas flow rate to the VOC sorption reactor as well as the VOC and water concentrations in the reactor gas supply. The gas handling system consisted of two N₂ supplies regulated at 25 psi. N₂ supply # 1 supplied the carrier gas flow for the reactor and the VOC carrier flow. The reactor carrier flow was set using a high resolution Porter control valve in line before an appropriate range rotameter. The VOC carrier flow was also controlled by a high resolution Porter control valve and the flow was monitored with a high resolution rotameter. A four-way valve following the rotameter allowed the VOC carrier to be directed through or bypass the VOC reservoir. N₂ supply # 2 was the carrier for the reactor water vapor supply. This flow was controlled by a rotameter equipped with a high resolution needle valve. Two three-way valves allowed the N₂ flow to bypass the water sparger or be directed through it. A 500 ml Pyrex sparger was used which contained 350 ml of deionized water. A Borden tube type vacuum/pressure gauge with a sensitivity of about 0.5 psi was mounted near the mixing point of the three carrier flows to monitor for excess reactor back pressure. For all sorbents used in this project, no detectable back pressure was observed. All tubing and fittings used in construction were stainless steel except for the connections between the glass sparger and the system tubing where short sections of Tygon tubing were used.

The VOC sorption reactor consisted of a vertically mounted Pyrex tube that was approximately 7-3/8 inches (19 cm) long having a 3/4 inch (1.9 cm) I.D. with a 1/16 inch (1.6 mm) wall thickness. The reactor tube was mounted to the system tubing using 3/4 inch to 1/8 inch stainless steel reducing unions with the glass to metal seal provided by teflon ferrules. The sorbent charge was located about 5 cm from the lower end of the reactor tube supported by a bed of Pyrex wool. A 1/16 inch diameter stainless steel sheathed type K thermocouple was mounted coaxially just below the sorbent bed. The gas flow through the reactor was downward to avoid the possibility of sorbent bed fluidization. Two three-way valves were used to direct the gas flow

HV = High resolution valve

PC = Personal computer

GC = Gas chromatograph

V-4 = 4-way valve

Int = Interface

SV = Sampling valve

V = 3-way valve

R = Rotameter

B = Sorbent bed

Sp = Sparger

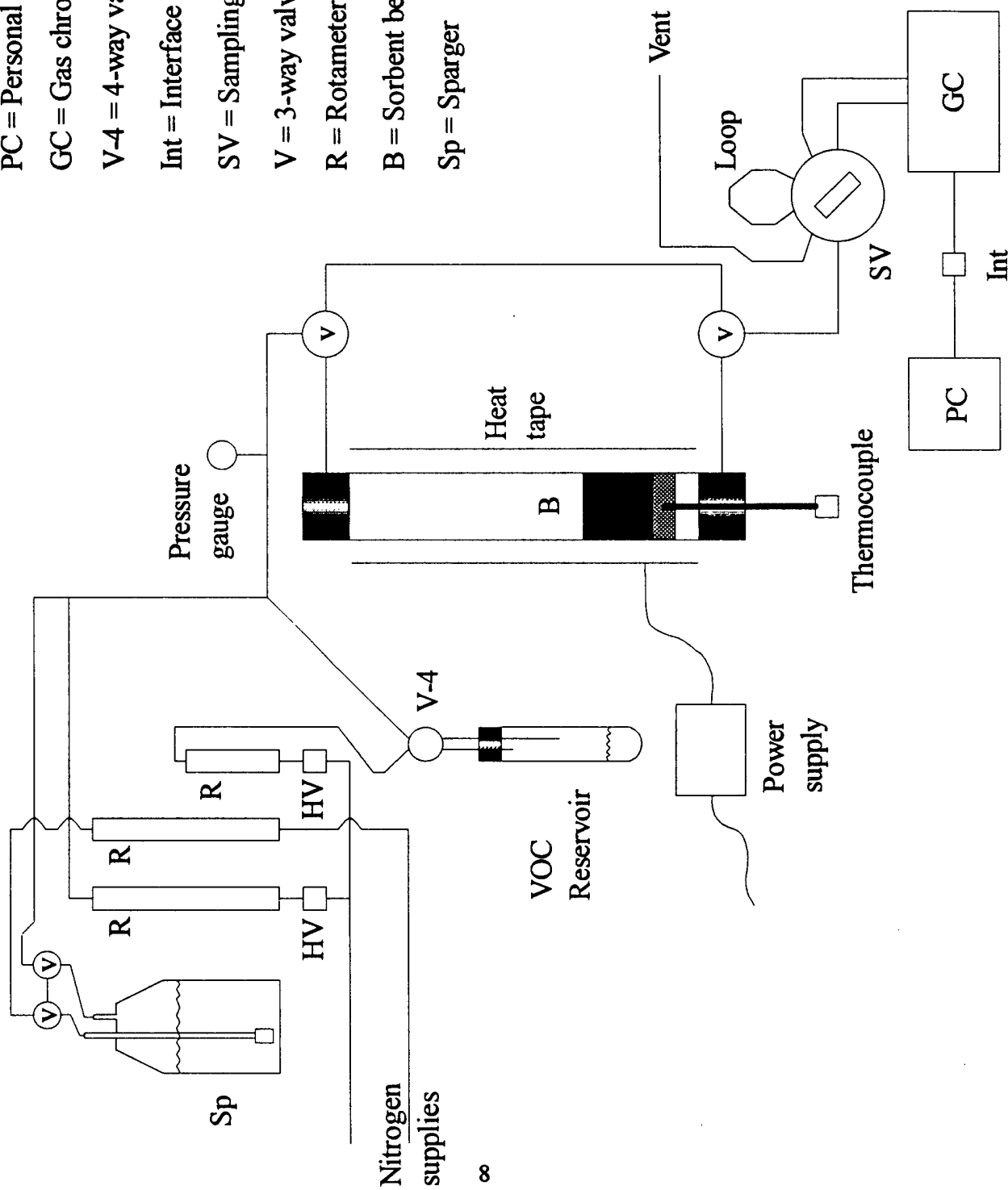

Figure 3. Diagram of VOC sorption reactor.

through the reactor or to bypass the reactor. A Valco six-way stainless steel sampling valve at the reactor outlet was used to sample the gas stream for measurement of the VOC concentration. A 5000 μ l sample loop was used.

Gas flow rates were calibrated using a bubble flow meter constructed from a 100 ml buret. Flows were determined based on the average of multiple readings. Following any system modifications, gas flow rates were rechecked.

A Shimadzu GC-9A gas chromatograph (GC) was used to measure the VOC concentration. The GC was operated isothermally at 240°C with the injection port at 275°C. Nitrogen was used as the carrier gas at 50 ml/min for analysis of MEK and TCE. Carrier flow was increased to 70 ml/min for analysis when toluene was used as the VOC to reduce the retention time. The GC was equipped with a flame ionization detector which was operated at maximum sensitivity for sorption experiments. An Alltech 6' x 1/8" stainless steel column packed with Super Q 80/100 was used. A Pentium PC equipped with Labtech Notebook software was used for data collection. A Computer Boards Inc. CIO-DAS08/Jr-AO I/O board was used to interface the GC to the computer and perform the A/D conversion.

The GC was calibrated for each VOC sorption experiment. Calibration was carried out by injecting known quantities of the compound of interest using a 1.0 μ l Hamilton syringe. Depending on the range to be calibrated, either the pure solvent or the solvent diluted in an appropriate amount of acetone was used. A calibration factor was determined for each experiment based on a minimum of five points.

2. Model VOCs

Three compounds, considered to be VOCs as well as hazardous air pollutants, were used as model VOCs for this project. These compounds were methyl ethyl ketone (MEK), trichloroethylene (TCE), and toluene. These compounds were selected to represent common solvents covering a range of chemical characteristics: a ketone, an unsaturated chlorinated compound, and an aromatic compound. These materials were all ACS grade having purities above 99 %. **Table 2** shows some of the characteristics of the model VOCs.

Table 2. Characteristics of model VOCs.

Compound	methyl ethyl ketone (2-butanone)	trichloroethylene	toluene
Molecular wt. (g/mol)	72.11	131.39	92.14
Boiling point (°C)	80	87.1	111
Compound type	saturated, ketone	unsaturated, chlorinated	aromatic

3. Typical Sorption and Regeneration Conditions and Procedure

Most of the sorbents studied in this project were tested for their VOC sorption characteristics using the following set of baseline conditions. Experiments were carried out at room temperature (typically 24 to 26°C) and atmospheric pressure using MEK as the model VOC. The gas flows used were 200 ml/min of N₂ for the water carrier, 48 ml/min N₂ for the dilution flow to prevent water condensation, and 2 ml/min of N₂ for the MEK carrier giving a combined flow of 250 ml/min. Under these conditions the water concentration was 2.3 percent. The target MEK concentration was 400 ppm. The actual MEK concentration was very sensitive to variations in the daily experimental conditions, therefore, the feed concentration was monitored during each sorption run. A sample size of 2.500 g was used for montmorillonite-based sorbents and 1.000 g for activated char sorbents.

The usual procedure followed for a VOC sorption experiment was as follows. The gas flows and GC were started and allowed to equilibrate for a minimum of 30 minutes with the reactor on bypass. During this period the sorbent was loaded in the reactor. Following the equilibration period, the GC was calibrated by standard injections. Additional calibration injections were usually made during the VOC sorption run to verify constant GC response. While the reactor was still on bypass, several sample valve injections were made to determine the VOC feed supply concentration. Additional bypass injections were made at the end of each VOC sorption experiment to verify that the VOC feed supply concentration did not change during the experiment. Also, for very long VOC sorption runs, the reactor was bypassed and the feed VOC concentration was checked during the run. Following the GC calibration and VOC feed concentration check, the sorption experiment was started by diverting the flow through the reactor. Once the sorption was started, samples were periodically injected into the GC with the sampling valve to monitor the VOC concentration at the reactor exit. The frequency of sample injection was based on previous experience with the sorbents. VOC sorption experiments were typically run until the concentration of VOC in the reactor exit flow approached the feed concentration (capacity) or until the exit flow concentration was over 10 percent of the feed concentration (breakthrough). At the end of the sorption cycle the gas flow was switched to bypass and the weight increase of the sorbent was measured. If the sample was going to be regenerated the VOC reservoir was also switched to bypass after the VOC feed concentration was rechecked.

Regeneration was typically carried out using the same gas flow division as used for VOC sorption except with the VOC reservoir bypassed resulting in a 250 ml/min flow of nitrogen containing 2.3 percent water. The reactor was heated for regeneration using heating tape which was controlled manually using a Variac. The final regeneration temperature was typically between 140 and 180°C. The wide temperature range reflects the difficulty in temperature control by this method. During regeneration the VOC adsorbed by the sorbent was found to be released quickly; therefore, the GC sensitivity was reduced to attempt to keep the detector in range. The GC was recalibrated for each regeneration test.

The typical procedure for regeneration was as follows. After recalibration of the GC, the regeneration gas stream was directed through the sorption reactor. Two minutes after the regeneration gas flow was diverted to the reactor, a sample was taken at room temperature and the reactor heating was started. A sample was then taken about every five minutes until the VOC concentration in the gas exiting the reactor dropped. The VOC concentration was monitored until it was no longer detectable. At this point, the reactor was cooled to room temperature usually under a moist nitrogen flow and the final weight was determined.

B. SORBENT PREPARATION

1. Montmorillonite-based Sorbents

The following sections describe the synthesis procedures employed for the preparation of the montmorillonite-based sorbents used in this study. The montmorillonite used in the synthesis of all clay based sorbents was a sodium montmorillonite from Crook County, Wyoming. This clay, designated SWy-2, was obtained from the Source Clay Minerals Repository at the University of Missouri, Columbia, Missouri. This clay is part of a stock of clays maintained by the Source Clay Minerals Repository to provide a consistent source of clays to researchers. SWy-2 is a replacement for SWy-1 and was obtained from the original deposit. SWy-2 has not yet been characterized by the Source Clay Minerals Repository but is expected to be equivalent to SWy-1 since the source was the same. Some characteristics of SWy-1, which were used as guidelines in the use of SWy-2, are given in **Table 3**.

Table 3. Characteristics of montmorillonite SWy-1.

Cation exchange capacity ⁴	76.4 meq/100 g
Primary exchangeable cations ⁴	Na, Ca
Surface area (N ₂ BET) ⁴	31.82±0.22 m ² /g
Surface area (N ₂ BET) ^a	30 m ² /g
Other phases present (determined by sedimentation and X-ray diffraction):	
Quartz, feldspar ⁵	

a = Surface area of SWy-2 as measured in our laboratory.

Two alkylammonium salts were used for the preparation of the OPM sorbents. These were tetra-*n*-butylammonium bromide and tetradecyltrimethylammonium bromide, both obtained from Spectrum Chemical and both with a minimum purity of 99 percent. The cationic portions of these salts were designated TNBA and TDTA, respectively, for simplicity. All water used in this project was deionized.

Prior to the preparation of sorbent samples in sufficient quantities for VOC sorption testing, experiments were carried out to identify difficulties that would be encountered in the planned synthesis procedure. Two experiments were done for this purpose. The procedure used to prepare the OPMs was based on previous experience with the synthesis of pillared clays

combined with the well known characteristics of montmorillonites. These OPMs were designated BH58-1 and BH58-2.

a. BH58-1 - Montmorillonite pillared with TNBA cations.

Sample BH58-1 was the synthesis procedure test for TNBA cations. This sample was prepared by slowly adding 12.5 g of SWy-2 to 450 ml of water and stirring the mixture for one hour. A solution of 15.3 g of TNBA bromide in 50 ml of water, 5 times the cation exchange capacity of the clay, was prepared during the equilibration period. Excess TNBA was used to promote complete cation exchange. The TNBA solution was added all at once to the clay dispersion. Immediately after the addition, the mixture flocculated and thickened to the point that it could no longer be stirred by the magnetic mixer. The mixture was stirred by hand and after a short period of time the viscosity dropped to the point that it would magnetically stir. The mixture was then stirred for 3 hours to equilibrate. Stirring was then stopped and the sample allowed to settle for 1 hour. After 1 hour, very little settling occurred. The sample was then filtered, washed, and dried at 50°C overnight then 105°C for several hours. The product consisted of hard gray chunks. No pelletization was attempted on this sample and no further characterization was done.

b. BH58-2 - Montmorillonite pillared with TDTA cations.

The preparation attempt of BH58-2 was essentially the same as that of BH58-1 except that TDTA bromide was substituted for TNBA bromide. SWy-2 (12.5 g) was dispersed in 450 ml of water and allowed to equilibrate for 1 hour at room temperature. During this time a solution of 15.78 g of TDTA bromide in 50 ml of water was prepared. The amount of TDTA used was about 5 times the cation exchange capacity of the clay. Again, excess TDTA was used to promote complete cation exchange. The TDTA solution was added all at once following the equilibrium period. Upon addition, the clay dispersion flocculated and became very viscous, although not as viscous as BH58-1. The viscosity slowly dropped and the flocs broke up with stirring. The sample was allowed to equilibrate for 3 hours. Filtering of the sample was attempted unsuccessfully. Foaming and filter clogging prevented removal and washing of the sample. This sample was not recovered for further testing.

Based on the results obtained in these two experiments, an OPM prepared using TNBA was selected for continued testing to avoid the problem of sample recovery from suspension. For the scaled up synthesis, a lower concentration clay dispersion was used and TNBA at 2.5 times the cation exchange capacity was used. These modifications were done to avoid the extreme viscosity encountered after addition of the alkylammonium solution to the clay suspension. These modifications are reflected in the preparation of BH58-8 below.

c. BH58-8 - Montmorillonite pillared with TNBA cations.

BH58-8 was prepared using the following procedure. Fifty grams SWy-2 was dispersed in 3000 ml of water and allowed to equilibrate for about 2 hours at room temperature. During this time a solution of 14.59 g of TNBA bromide in 50 ml of water was prepared. The amount of TNBA used was about 2.5 times the cation exchange capacity of the clay. Again, the excess TNBA was used to promote complete cation exchange. The TNBA solution was added all at once following the equilibrium period. Upon addition, the clay dispersion still flocculated and became very viscous. However, the viscosity slowly dropped and the flocs broke up with stirring. The sample was stirred overnight. The sample was then allowed to settle for 2 hours and the clear solution decanted. The remaining dispersion was filtered and washed. The moist clay filter cake was pelletized by extrusion using a plastic syringe. The extruded sample was dried at 150°C overnight and then at 250°C for 2 hours. The resulting extrusions were broken into random length pieces and those with a size of approximately 1.5 mm diameter by 3 mm long were separated for testing.

d. BH58-87 - Montmorillonite pillared with 0.5 x CEC of TNBA.

A sorbent consisting of SWy-2 pillared with TNBA at one half of its cation exchange capacity was prepared. The purpose of this synthesis was to replace only a portion of the exchangeable cations and attempt to avoid complete filling of the interlayer space by the TNBA cations. The procedure used was similar to that used for BH58-8. Ten grams of SWy-2 was dispersed in 750 ml of water and allowed to equilibrate for 2 hours. Following the equilibration period, the suspension was allowed to settle for two minutes and then decanted. The settling period allowed much of the dense mineral contaminants to settle and be removed. For this sample, 4.8 percent of the starting material was removed which, by visual inspection, consisted mostly of darker coarse grains. This material was not analyzed but was expected to be primarily quartz and feldspar as reported for SWy-1⁵ and would be expected to have a very low surface area. A previously prepared solution of 1.21 g of TNBA bromide in 50 ml of water was added to the stirring clay suspension. Upon addition, the mixture flocculated and thickened followed by a slow viscosity decrease. After a 2 hour equilibration period, the sample was filtered, washed, extruded, and dried as described above. This sample was designated BH58-87.

e. BH58-24 - Montmorillonite with colloidal alumina and TNBA.

In an attempt to increase and stabilize the clay layer separation, inorganic pillaring was attempted followed by modification with TNBA cations. The method used for the preparation of this material was as follows. SWy-2 was dispersed in water at about a 1 percent by weight concentration and allowed to equilibrate overnight. A commercially available colloidal alumina from Alfa Products was obtained which contained 20 percent by weight alumina with a particle size range of 0.0005 to 0.03 microns. The pH of the dispersion was adjusted to approximately 4 with nitric acid to match the pH and counter ion of the colloidal alumina before its addition. The colloidal alumina was added to the clay dispersion creating a weight ratio of 1 g alumina to 2 g of

clay. This mixture was allowed to equilibrate about 6 hours before the addition of TNBA equal to the initial cation exchange capacity of the clay. After aging overnight, the product was separated by filtration, washed, and extruded to form pellets before drying. The pellets were dried at 150°C overnight and then at 250°C for 2 hours. The resulting pellets were cylindrical with a diameter of about 1 mm and of random lengths.

f. BH58-25 - Montmorillonite with colloidal alumina.

BH58-25 was prepared by the same procedure as that used for BH58-24 except that the TNBA addition step was omitted. The sample was pelletized and dried in the same manner. This sample was prepared to determine if colloidal alumina pillaring was achieved.

g. BH58-32 - Montmorillonite pillared with Al_{13} Keggin ions.

A montmorillonite pillared with aluminum oxide, BH58-32, was prepared by a procedure well documented in the literature⁶. No additional organic cation modifications were used for this sample. To prepare this sample a pillaring species commonly designated as an aluminum Keggin ion was synthesized and exchanged into the montmorillonite. This cationic species has the ideal formula $AlO_4Al_{12}(OH)_{24}(H_2O)_{12}^{7+}$ and was designated as Al_{13} Keggin ion. This sample was prepared by dispersing 10 grams of SWy-2 montmorillonite in 1000 ml of water and equilibrating overnight. The Keggin ion solution was prepared by the controlled hydrolysis of an aluminum nitrate solution with sodium hydroxide. A 0.2 M solution of sodium hydroxide was added dropwise to a stirred 0.2 M solution of aluminum nitrate at room temperature. A molar ratio of 1 Al to 2.5 OH was used for this preparation. This solution was also aged at room temperature overnight. The resulting Keggin ion solution was colorless and very slightly turbid. The pH of the clay suspension was adjusted to about 3.5 with nitric acid before adding the Keggin ion solution. The Keggin ion solution was then added slowly to the clay suspension at room temperature and the mixture was allowed to equilibrate. A ratio of 2.75 millimoles of Al per gram of clay was used. During the addition the mixture became very viscous. The pH increased to 4.25 after the addition. The product was isolated by filtration and pelletized by extrusion before drying at 250°C.

h. BH58-37 - Pelletized SWy-2 montmorillonite.

Chemically unmodified SWy-2 montmorillonite was pelletized for use as a baseline VOC sorbent sample. The clay was pelletized by preparing a very viscous slurry of 10 g of SWy-2 with 60 g of water. The mixture was stirred and equilibrated for 3 hours before extrusion and drying at 250°C. This sample was designated as BH58-37.

i. BH58-69 - Montmorillonite-silica gel composite.

For this sample, silica derived from tetraethoxysilane (TEOS) was used in an attempt to hold the clay layers apart. This sample was prepared by making a viscous clay/water gel using

SWy-2 montmorillonite. TEOS, slightly diluted with ethanol, was mixed with the clay gel. A 1-to-1 weight ratio of SWy-2 to TEOS was used. The sample was allowed to equilibrate overnight resulting in a stiff, rubbery gel. This material was extruded, dried at 175°C, and then at 250°C. This sample was designated as BH58-69.

2. Activated Char Sorbents

Several activated chars were tested for their performance as VOC sorbents. These materials were obtained from the Illinois State Geological Survey (ISGS). The activated chars were produced directly from Illinois coal by a proprietary pyrolysis and chemical activation process. The basic steps used for the preparation of the chars were to initially clean the coal to remove major impurities and then grind it to the desired mesh size. The coal was then pyrolyzed, typically in a nitrogen atmosphere, at 600 to 1000°C. The pyrolysis could be carried out in a fixed bed, fluidized bed, or continuous rotary kiln. Following pyrolysis, the chars were chemically activated to increase the internal surface area. The chars were then treated by a proprietary process to modify the pore structure and surface chemistry to tailor the char's characteristics for its intended end use.

3. Commercial Sorbents

a. Activated alumina

A spherical activated alumina produced by Alcoa designated HPX was used as the initial benchmark of sorbent performance until an activated carbon produced specifically for VOC control was obtained for a more realistic comparison. The activated alumina consisted of spherical particles having an approximate diameter of 1.2 mm and a surface area of 340 m²/g.

b. Activated carbon

A sample of activated carbon produced commercially for use in VOC control was obtained. This material consisted of irregularly shaped particles which were crushed and sieved to -20+70 mesh. This material will be referred to as VOC carbon throughout this report.

C. SORBENT CHARACTERIZATION

Two methods were typically used for the characterization of sorbent materials in addition to their VOC sorption activities. Surface area measurements were used to evaluate the success of the pillaring process. Effective pillaring is expected to result in a surface area increase as the internal clay volume becomes available for adsorption. For activated chars, surface areas were measured to determine the area available for VOC adsorption. Powder X-ray diffraction (XRD) was used to measure the layer separation achieved by the pillaring process. XRD was also used to identify the crystalline phases present in the sorbents studied. Also, a low temperature

oxidation was used to determine the ash content of one char sample. Brief descriptions of these techniques follow.

1. Surface Area Measurements

Surface areas were determined using a Micromeritics FlowSorb 2300 with AutoMate 23. This instrument can be used for single or multipoint surface area measurements; however, single point measurements were typically used to increase sample throughput. Surface area standards were periodically run to verify the accuracy of the measurements. A gas mixture of 30.73 percent nitrogen in helium was used in the measurements in this study. Instrument calibration was carried out for each sample measurement. The sample surface area was calculated using a form of the BET equation.

2. Powder X-ray Diffraction

Powder XRD analysis of the materials used in this study was done off-site using a Rigaku Geigerflex X-ray diffractometer. The diffractometer was equipped with a Cu X-ray tube and a monochromator. Samples were typically scanned over the range of 4 to 70 degrees 2θ using a step size of 0.03 degrees 2θ and a count time of 2 seconds per step. Jade 3.0 was used for data reduction.

3. Low Temperature Oxidation

A low temperature oxidation procedure was used to remove the carbonaceous portion of a char sample to determine its ash content. The procedure used was as follows. The char was dried at 250°C for 2 hours in air. About 0.25 g of dry char, accurately weighed, was placed in a preweighed crucible. The crucible was placed in a 500°C furnace in air and held for 6 days. The sample was then cooled in a desiccator and weighed. The ash weight was determined by the difference.

SECTION III

RESULTS AND DISCUSSION

A. Results for Montmorillonite Based Sorbents

1. Montmorillonite Pillared With Alkylammonium Cations

Four syntheses were attempted using alkylammonium cations as the pillaring species. The characterization results for these samples are summarized in **Table 4**. Prior to the preparation of samples for VOC sorption tests, small scale tests of the planned synthesis procedure were carried out using TNBA (BH58-1) and TDTA (BH58-2) cations. The same preparation procedure was used for both samples. These tests were used to identify potential difficulties that would be encountered in the use of these pillaring species prior to scale-up of the preparation. The products from these experiments were not characterized further.

a. OPM synthesis procedure test samples

The test preparation using TNBA showed no major procedural difficulties. The thickening encountered upon addition of the TNBA solution to the montmorillonite suspension could probably be overcome by lowering the clay concentration.

The test preparation using TDTA, however, had more severe problems. While the thickening encountered upon addition of the TDTA solution to the montmorillonite suspension was not as severe, a problem with solution foaming and filter clogging prevented recovery of the product by filtration. The product could have been recovered by centrifugation; however, this option was not available on site.

Based on the results of these two tests, TNBA was selected for synthesis scale-up to produce OPM sorbent for VOC removal testing.

Table 4. Summary of characteristics of alkylammonium-pillared montmorillonites.

Sample designation	Description	Surface area (m ² /g)	Layer separation (Å)
BH58-1	SWy-2 + 5.0 times CEC of TNBA	N.A.	N.A.
BH58-2	SWy-2 + 5.0 times CEC of TDTA	N.A.	N.A.
BH58-8	SWy-2 + 2.5 times CEC of TNBA	18	4.6
BH58-87	SWy-2 + 0.5 times CEC of TNBA	22	4.5

N.A. = not analyzed

b. BH58-8 - Montmorillonite pillared with TNBA cations

Based on the procedural modifications suggested by the TNBA test run, a larger sample of TNBA-pillared montmorillonite, BH58-8, was prepared for VOC sorption testing. Lowering the clay concentration by about one half and lowering the TNBA to clay ratio by one-half resulted in a mixture that was still stirrable after the clay suspension and TNBA solution were mixed. The viscosity of the suspension still increased but remained acceptable. The dried, pelletized product was characterized by X-ray diffraction and surface area analysis. The results are given in **Table 4**.

The surface area of the pelletized TNBA exchanged montmorillonite was determined to be 18 m²/g while that of pelletized SWy-2 was 33 m²/g. The TNBA exchange procedure resulted in a loss of 15 m²/g. However, the X-ray diffraction analysis of BH58-8 showed that the clay layers were separated by 4.6 Å through the pillaring procedure. This clay-layer separation indicated that the TNBA cations were successfully exchanged into the clay by the experimental procedure even though the surface area decreased. The reduction in surface area resulting from the preparation procedure was probably due to increased ordering of the clay-layer stacking. Evidence for this conclusion was provided by the XRD analysis. The montmorillonite (001) or basal peak showed a significant increase in intensity and a decrease in peak width suggesting a more ordered layer stacking. This change in peak shape is illustrated in **Figure 4** where the (001) peak of BH58-8 is shown superimposed over the (001) peak of unexchanged SWy-2. The shift in peak position for BH58-8 to a lower 2θ value relative to the unexchanged montmorillonite reflects the increased clay layer separation resulting from the TNBA exchange. In addition, since the surface area dropped and the TNBA was exchanged in between the clay layers, it is likely that the interlayer volume was completely filled by the exchanged TNBA cations resulting in a TNBA monolayer between montmorillonite layers. This proposed explanation of the experimental results is shown schematically in **Figure 5**.

BH58-8 was prepared using TNBA at about 2.5 times the CEC of SWy-2; therefore, a sufficient amount of TNBA was available for essentially complete replacement of the exchangeable cations in the clay. As suggested above, this resulted in complete filling of the available volume between the clay layers; therefore, a sample was prepared using TNBA at only 0.5 times the CEC. Using only half of the CEC of TNBA would result in only partial exchange, possibly resulting in accessible interlayer porosity. This approach was used in the preparation of BH58-87.

c. BH58-87 - Montmorillonite pillared with 0.5 x CEC of TNBA

SWy-2 exchanged with only one half of the CEC of TNBA resulted in an OPM having nearly the same characteristics as those of BH58-8 as shown in **Table 4**. The resulting clay-layer separation was 4.5 Å with a surface area of 22 m²/g. The basal peak was also intense and narrow as seen for BH58-8 suggesting that the clay-layer stacking order was again improved.

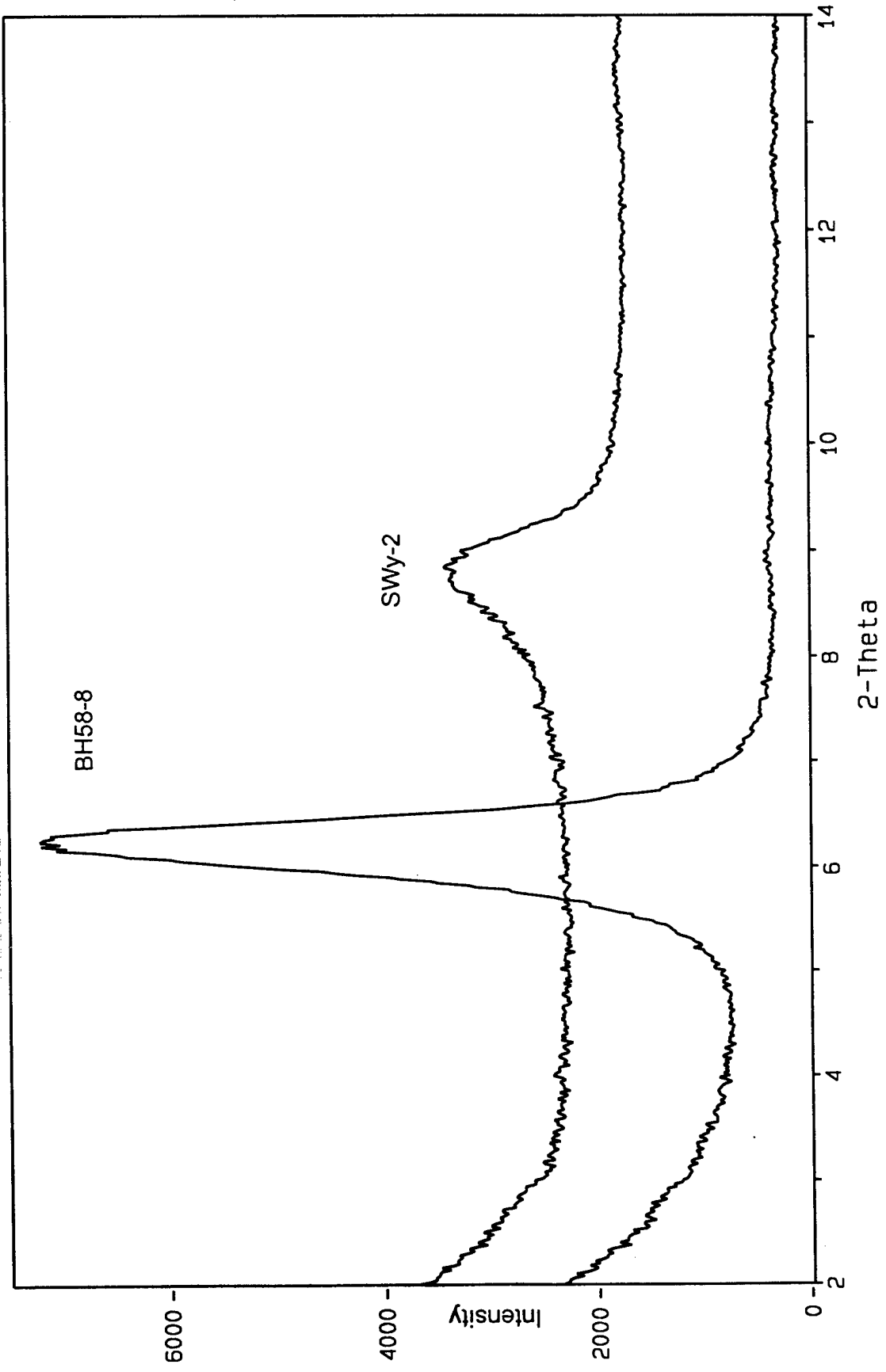
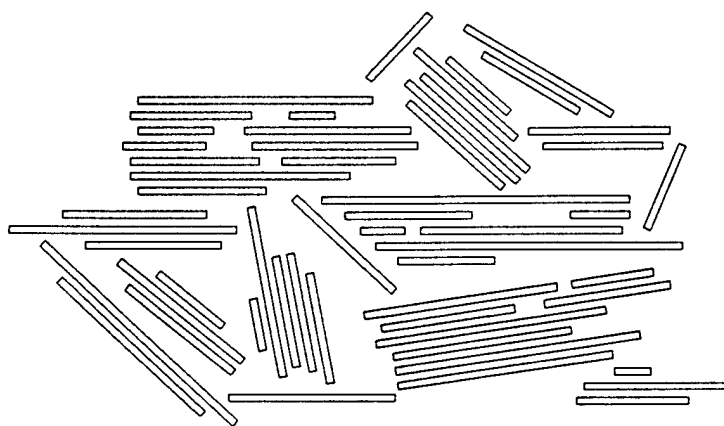

Figure 4. Comparison of basal peak position and shape for BH58-8 and exchanged SWy-2.



Dried montmorillonite before exchange - poorly organized clay layer stacking.

$$\Delta d = 0 \text{ \AA}$$



TNBA exchange reaction

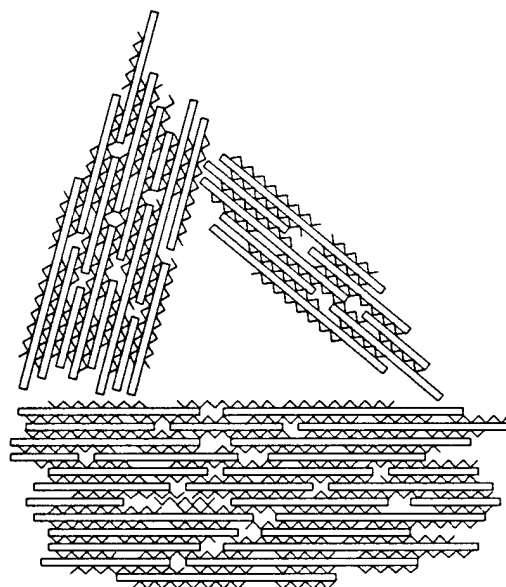

After exchange - improved organization of structure consisting of alternating clay layers and TNBA layers.

$$\Delta d = 4.6 \text{ \AA}$$

~~~~~ Represents TNBA monolayer

Figure 5. Diagram of proposed result of TNBA exchange reaction.

A possible explanation for the similar results obtained for these two samples prepared with excess TNBA versus half of the CEC of TNBA is as follows: the TNBA cation is much larger than the naturally occurring exchangeable inorganic cations that were replaced; therefore, the TNBA will occupy a larger portion of the clay-layer surface than the originally present cations. In addition, the TNBA cation has four linear *n*-butyl groups in a tetrahedral geometry about a central nitrogen; however, the *n*-butyl groups are flexible and easily distorted so when the TNBA cations are exchanged between the clay layers, electrostatic attraction between the stacked negatively-charged layers and positively-charged cations could somewhat compress and flatten the TNBA cations. This would result in the TNBA cation occupying even more surface area. The actual extent to which the TNBA replaces the original cations could, as a result, be sterically limited so that resulting TNBA exchanged clay would in reality be partly TNBA and partly the original cations. A steric exchange limit such as this could cause the clay to be exchanged to the maximum extent possible with TNBA even at only a fraction of the CEC. The result of an effect such as this could be that BH58-8 and BH58-87 are essentially identical as their characterization appears to indicate. This explanation could be verified experimentally but is beyond the scope of this project.

d. BH58-37 - Pelletized SWy-2 montmorillonite

BH58-37 was prepared to provide a baseline sample for comparison of the chemical and physical characteristics and VOC removal abilities of modified montmorillonites. The pelletization process resulted in very little surface area change as expected. The as-received clay had a surface area of 30 m<sup>2</sup>/g versus 33 m<sup>2</sup>/g after pelletization. This difference is within the error of our surface area measurement.

## 2. VOC Capacity Tests of TNBA-Pillared Montmorillonites

BH58-8 was tested for its ability to remove MEK from a gas stream. Its activity was compared to BH58-37 and HPX activated alumina using the same experimental conditions. BH58-87 was not run with this sample series because, based on the characterization results, the VOC sorption activity would be predicted to be similar to BH58-8. The standard reaction conditions listed in reaction II.A.3 were used with the following exceptions. The sorption was run under dry conditions using a sample size of 2.50 g. The larger sample size was used because the capacity was expected to be low based on the low measured surface area. The sorption activity curves for BH58-8 versus BH58-37 and HPX activated alumina are shown in **Figure 6** and a summary of the results is given in **Table 5**. Activated alumina was used for the initial capacity comparisons because no samples of commercial VOC removal sorbents were available early in this study.

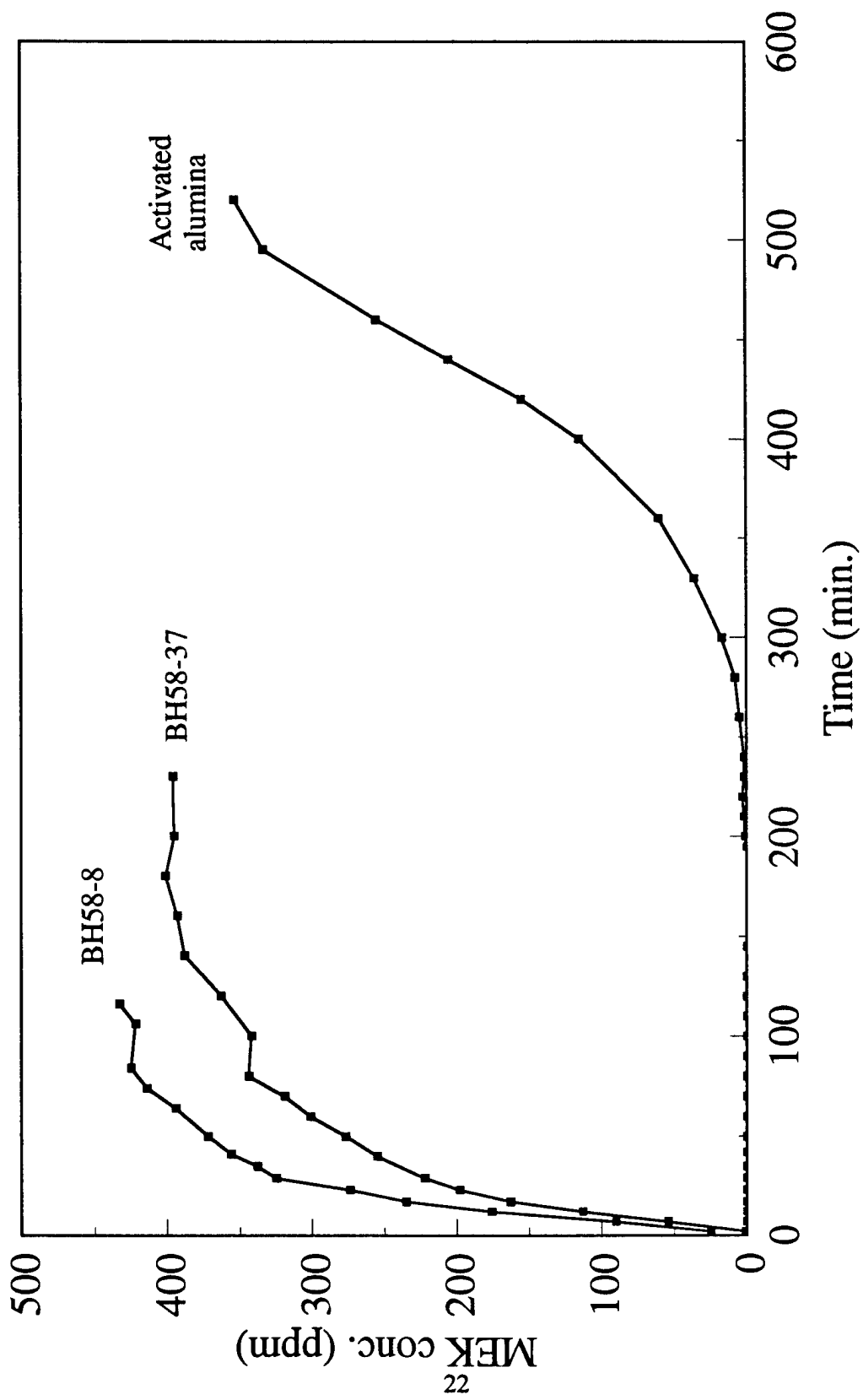

Figure 6. Comparison of MEK sorption behavior of BH58-8, BH58-37 and activated alumina under dry conditions.

**Table 5.** Summary of MEK sorption characteristics of alkylammonium exchanged montmorillonites versus activated alumina.

| Sample name                               | BH58-8                    | BH58-37           | HPX               |
|-------------------------------------------|---------------------------|-------------------|-------------------|
| Description                               | SWy-2 + 2.5 x CEC of TNBA | SWy-2, pelletized | Activated alumina |
| Surface area (m <sup>2</sup> /g)          | 18                        | 33                | 340               |
| MEK feed conc. (ppm)                      | 478                       | 436               | 422               |
| Capacity <sup>a</sup> (mg MEK/ g sorbent) | 0.46                      | 0.69              | 38.89             |
| Breakthrough time <sup>a</sup> (min.)     | 4                         | 6                 | 340               |

a = at breakthrough of MEK at 10% of the feed concentration.

The sorption curves shown in **Figure 6** indicated that BH58-8 had a lower capacity for MEK than unmodified montmorillonite and that both clay-based materials had much lower capacities than the activated alumina. The lower capacity of BH58-8 versus the unmodified clay probably reflects the decrease in surface area resulting from the increased clay-layer stacking order induced by the TNBA exchange procedure. The fact that the activated alumina, which is not a good VOC sorbent, performed much better than the TNBA-exchanged sorbent shows that much improvement was needed in the clay-based sorbent performance.

Due to the above experimental results, methods to improve the performance of the clay-based sorbent were sought. The first approach considered was the identification of a better organic cation to act as the pillaring species. The replacement pillar must be positively charged to enable exchange between the clay layers. In addition, the replacement pillar must be large and rigid enough to prop the clay layers apart to induce accessible porosity. It must also be able to survive the sorbent drying and regeneration process without decomposition. An additional constraint is cost. The pillaring material must be sufficiently inexpensive to allow its use in a cost-effective sorbent preparation. No compounds were identified that could satisfy these requirements; therefore, other alternatives were explored. The first alternative was to utilize thermally stable rigid inorganic pillaring materials to produce a stable porous pillared clay. Sorbents produced to explore this approach are discussed in the next section.

### 3. Montmorillonite Modified by Inorganic Materials

Three approaches were used to modify montmorillonite with inorganic materials. Two approaches were based on methods reported in the literature for pillaring montmorillonites. The first approach tried was pillaring with positively charged colloidal alumina<sup>7</sup>. The second approach was pillaring with Al<sub>13</sub> Keggin ions<sup>6</sup>. A third montmorillonite based sorbent was prepared which was designed to be a montmorillonite-silica gel composite rather than a pillared clay. The results obtained with these approaches are discussed below. The results are also summarized in **Table 6**

along with BH58-8, BH58-87, and BH58-37 for comparison. The VOC sorption results for all of these samples will be discussed below.

**Table 6.** Summary of characteristics of modified montmorillonite sorbents prepared for this study.

| Sample designation | Description                          | Surface area (m <sup>2</sup> /g) | Layer separation (Å) |
|--------------------|--------------------------------------|----------------------------------|----------------------|
| BH58-8             | SWy-2 + 2.5 times CEC of TNBA        | 18                               | 4.6                  |
| BH58-87            | SWy-2 + 0.5 times CEC of TNBA        | 22                               | 4.5                  |
| BH58-24            | SWy-2 + colloidal alumina + TNBA     | 103                              | 4.6                  |
| BH58-25            | SWy-2 + colloidal alumina            | 114                              | 2.7                  |
| BH58-32            | SWy-2 + Al <sub>13</sub> Keggin ions | 184                              | 6.4                  |
| BH58-69            | SWy-2/silica gel composite           | 255                              | Inconclusive         |
| BH58-37            | Pelletized SWy-2                     | 33                               | 0                    |

a. Montmorillonite modified with colloidal alumina.

Two samples of montmorillonite were prepared using colloidal alumina. The first, BH58-24, was prepared by exchanging colloidal alumina into SWy-2 followed by impregnation with TNBA. The second sample, BH58-25, consisted of SWy-2 exchanged with colloidal alumina. No TNBA was added to BH58-25. This sample was prepared to allow isolation of the effect of colloidal alumina addition.

X-ray diffraction analysis of BH58-25 (no TNBA) was inconclusive. A weak broad basal peak was present indicating a layer separation of about 2.7 Å after drying at 250°C. The average colloidal alumina particle diameter was reported as 0.0005 to 0.03 microns or 5 to 300 Å. The layer separation resulting from intercalation of particles of this diameter range would shift the basal peak to an angle outside the range of the X-ray diffractometer used for the measurement; therefore, no basal peak would be observed. The 2.7 Å layer separation that was observed was too small to have been caused by exchange of an aluminum oxide-like species and too large to result from exchange of simple ionic species. The cause of this layer separation was not determined. X-ray diffraction also showed that boehmite (AlOOH) was present in this sample which resulted from the alumina colloid. The surface area of BH58-25 was 114 m<sup>2</sup>/g. Successful intercalation of the colloidal alumina would be expected to give a much larger surface area because the volume between the clay layers would be accessible. Based on these results, the colloidal alumina was not exchanged between the clay layers. The increase in surface area could be attributed to the physical mixing of montmorillonite crystals with boehmite particles.

X-ray diffraction analysis of BH58-24, montmorillonite exchanged with colloidal alumina followed by exchange with TNBA, showed a strong sharp basal peak which gave a layer separation of 4.6 Å. No basal peak for a 2.7 Å layer separation was detectable. Boehmite was also present in this sample at about the same concentration as found for BH58-25. The surface area was 103 m<sup>2</sup>/g. These results suggest that the material resulting from this preparation was a mixture of TNBA intercalated montmorillonite and boehmite. The TNBA intercalated montmorillonite portion was probably very similar to BH58-8 and BH58-87 based on the layer separation and would be expected to have a low surface area while the boehmite portion was probably responsible for the majority of the surface area.

b. Montmorillonite pillared with Al<sub>13</sub> Keggin ions

The second approach utilizing inorganic pillaring was the exchange of Al<sub>13</sub> Keggin ions between the clay layers. This procedure is well documented in the literature<sup>6</sup>. The resulting Al<sub>13</sub> pillared montmorillonite is expected to have a layer separation of about 8 Å and a surface area above 150 m<sup>2</sup>/g. Since a small layer separation is expected for this material, no TNBA was added to avoid filling of the interlayer pores. The sorbent prepared based on this approach was designated BH58-32. X-ray diffraction showed two broad basal peaks. The strongest peak corresponded to a layer separation of 6.4 Å. The weaker peak was due to montmorillonite with no layer separation. Based on visual estimation, about 75 percent of the clay was pillared by this preparation. The surface area of the clay was increased to 184 m<sup>2</sup>/g by the intralayer porosity induced by the Al<sub>13</sub> pillaring. Although the layer separation was less than expected and a portion of the clay was not pillared, this sample was considered adequate for VOC sorption testing to determine the potential of this approach.

c. Montmorillonite-silica gel composite

BH58-69 was prepared using a different approach than that used for previous samples. For this sample, silica derived from tetraethoxysilane (TEOS) was used to attempt to hold the clay layers apart. As the TEOS hydrolyzed to silica gel, some TEOS could react with the hydroxyl groups terminating the clay layer edges. The formation of bonds between the clay-layer edges and the gel matrix would lock the clay layers in place in the gel structure preventing them from restacking resulting in a disorganized structure and a higher surface area. The material resulting from this synthesis had a surface area of 255 m<sup>2</sup>/g. The results of the X-ray diffraction analysis were inconclusive. The presence of a small montmorillonite basal diffraction peak at 9.6 Å, with no clay layer separation, indicated that at least a fraction of the clay layers were not significantly separated. However, the diffraction pattern also indicated some disorder in the clay structure which could be due to the silica gel locking some of the clay layers into a random structure. The surface area increase could, however, also be in part due to porosity in the silica gel produced in this procedure. No crystalline phases except montmorillonite were detected by X-ray diffraction. The exact cause of the surface area increase for this sample could not be determined by the characterization carried out.

#### 4. VOC Capacity Tests of Montmorillonite Modified With Inorganic Materials

The montmorillonites modified with inorganic materials, BH58-24, BH58-25 and BH58-32, were tested for their ability to remove MEK from a gas stream. Their activities were compared to BH58-8, BH58-37, and HPX activated alumina. The standard reaction conditions listed in II.A.3 were used with the following exceptions. The sorptions were run under dry conditions using a sample size of 2.50 g. The larger sample size was used because the capacities were still expected to be relatively low since, even though their surface areas were much improved over the TNBA/montmorillonite sorbents, their surface areas were still less than the activated alumina. The sorption activity curves for BH58-24, BH58-25, and BH58-32 versus BH58-8, BH58-37, and HPX activated alumina are shown in Figure 7 and a summary of the results is given in Table 7.

**Table 7.** Summary of MEK sorption characteristics of inorganically modified montmorillonites. BH58-8 and activated alumina are included for comparison.

| Sample name                              | BH58-8                 | BH58-24                          | BH58-25                   | BH58-32                              | BH58-37           | HPX               |
|------------------------------------------|------------------------|----------------------------------|---------------------------|--------------------------------------|-------------------|-------------------|
| Description                              | SWy-2 + 2.5 x CEC TNBA | SWy-2 + colloidal alumina + TNBA | SWy-2 + colloidal alumina | SWy-2 + Al <sub>13</sub> Keggin ions | SWy-2, pelletized | Activated alumina |
| Surface area (m <sup>2</sup> /g)         | 18                     | 103                              | 114                       | 184                                  | 33                | 340               |
| MEK feed conc. (ppm)                     | 478                    | 459                              | 437                       | 402                                  | 436               | 422               |
| Capacity <sup>a</sup> (g MEK/ g sorbent) | 0.00046                | 0.00648                          | 0.01585                   | 0.00045                              | 0.00069           | 0.03889           |
| Breakthrough time <sup>a</sup> (min.)    | 4                      | 53                               | 151                       | 4                                    | 6                 | 340               |

a = at breakthrough of MEK at 10% of the feed concentration.

##### a. BH58-24 and BH58-25

Both BH58-24 and BH58-25 had much higher MEK capacities than BH58-8 as seen in Figure 7. This increased capacity could probably be attributed primarily to the increased surface area due to the contribution of the boehmite particles. A possible explanation of the much higher capacity of BH58-25 versus BH58-24 may be the migration of MEK into available space between the clay layers and/or clay crystals and the pores in the colloidal alumina which are occupied by TNBA in BH58-24. X-ray diffraction results show that the clay layers are well organized in BH58-24 while the layers are disorganized in BH58-25 which could be a contributing factor since disorganized stacking of the clay layers would tend to provide additional sorption sites. The drop in the MEK curve for BH58-25 at about 180 minutes is probably due to migration of MEK into smaller internal pores of the sorbent during an overnight pause of the sorption experiment. This MEK migration probably freed occupied surface sites providing additional sorption capacity when

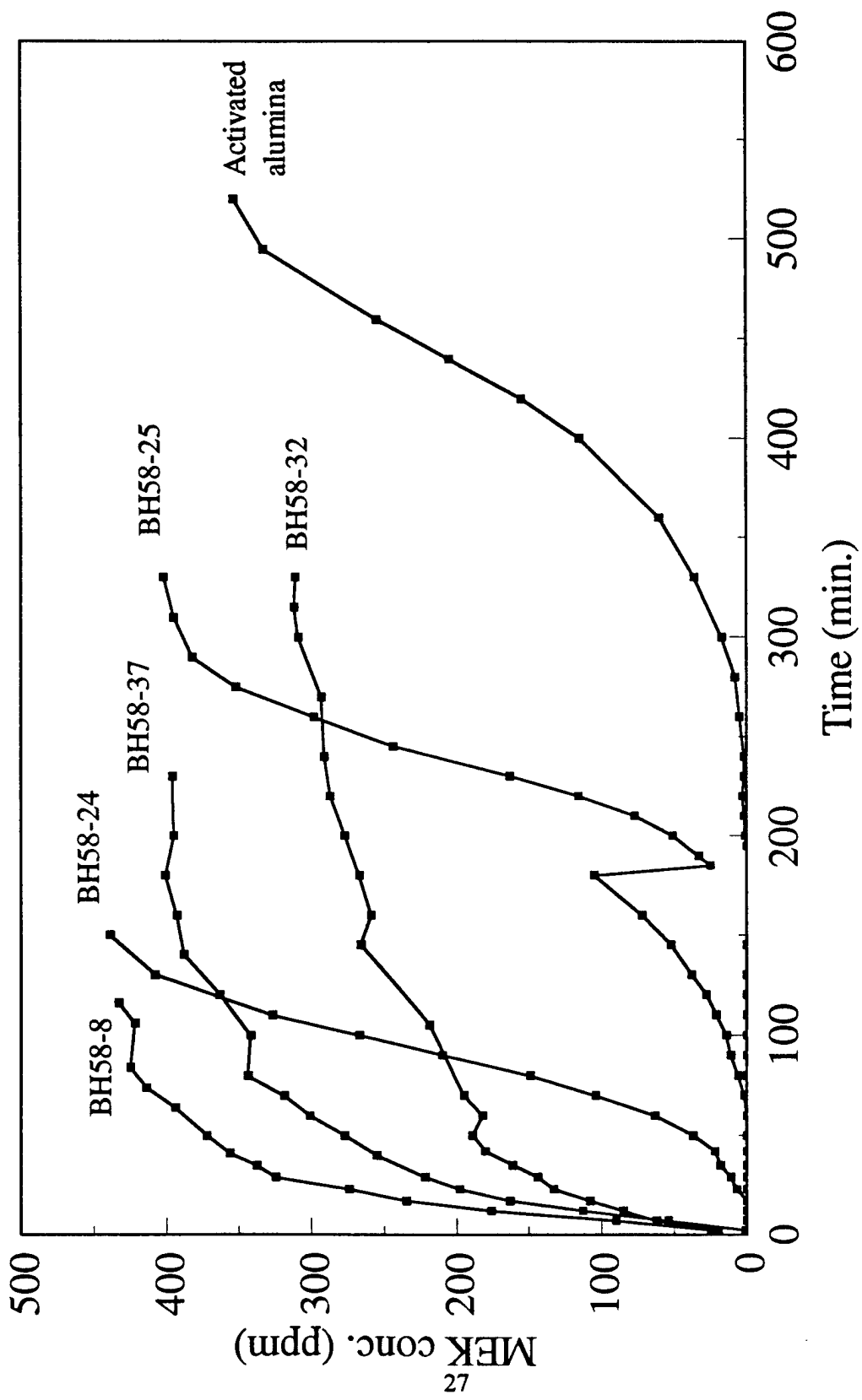

Figure 7. Comparison of MEK sorption behavior of BH58-8, -37, -24, -25, and -32 versus HPX activated alumina under dry conditions.

the experiment was restarted. Further characterization would be required to determine the precise reason for the sorption behavior differences between these two samples.

b. BH58-32

BH58-32 was modified by the addition of  $Al_{13}$  Keggin ions resulting in a substantially increased surface area of  $184 \text{ m}^2/\text{g}$ . The MEK sorption results are shown in Figure 7. This sample showed a fast breakthrough of MEK; however, it retained some sorption capacity throughout the run. This sorption behavior is probably due to the relatively high surface area but small pore dimension of  $6.4 \text{ \AA}$  between the clay layers. The small layer separation limits the rate of diffusion of MEK into the space between the layers. The readily accessible sorption capacity is quickly exhausted allowing breakthrough of the sorbent bed. However, the slow migration of MEK into the less accessible pores continually frees some of the surface for continued sorption so that some of the MEK feed is still collected.

Sorbents BH58-24, BH58-25, and BH58-32 have shown large improvements in performance for MEK adsorption under dry conditions as compared to unmodified montmorillonite and TNBA-exchanged montmorillonite. BH58-25, the clay-based sorbent having the best performance so far, had a capacity for MEK at 10 percent breakthrough that was 35 times that of BH58-8. However, its capacity was still less than half that of the activated alumina.

## 5. VOC Capacity Tests Under Moist Conditions

Up to this point in sorbent capacity testing, all experiments were carried out under dry conditions. Under the conditions of actual use, the VOC contaminated air stream would contain some water vapor. The water vapor concentration would depend on such variables as the area of the country at which the site was located, the time of year, and whether any atmospheric treatment was used to reduce the water vapor concentration. To more realistically test the sorbents prepared in this study, VOC sorption tests were carried out using a nitrogen flow containing 2.3 % water vapor. All other experimental conditions were unchanged. Nitrogen was used even though air would have been preferred. It was found that the oxygen in air quickly degraded the GC columns being used. Initially, the MEK removal performance of BH58-25, the best sorbent tested so far, was compared to that of activated alumina. BH58-69 was also run under these conditions because its high surface area would be expected to result in a good VOC capacity. Other previous samples were not tested because their already low MEK capacities would be expected to be further reduced in the presence of water vapor.

a. MEK capacities of BH58-25 and BH58-69

The MEK capacities of BH58-25 versus activated alumina under dry and moist conditions and BH58-69 under moist conditions are shown in Table 8. Figure 8 shows the MEK capacity curves for these samples under moist conditions.

**Table 8.** MEK sorption characteristics for BH58-25, BH58-69, and activated alumina under dry and moist conditions.

| Sample name                              | BH58-25                   | BH58-69 <sup>b</sup> | HPX               |
|------------------------------------------|---------------------------|----------------------|-------------------|
| Description                              | SWy-2 + colloidal alumina | SWy-2 + silica gel   | Activated alumina |
| Surface area (m <sup>2</sup> /g)         | 114                       | 255                  | 340               |
| <u>Dry nitrogen</u>                      |                           |                      |                   |
| MEK feed conc. (ppm)                     | 437                       | -                    | 422               |
| Capacity <sup>a</sup> (g MEK/ g sorbent) | 0.01585                   | -                    | 0.03889           |
| Breakthrough time <sup>a</sup> (min.)    | 151                       | -                    | 340               |
| <u>Moist nitrogen</u>                    |                           |                      |                   |
| MEK feed conc. (ppm)                     | 371                       | 342                  | 377               |
| Capacity <sup>a</sup> (g MEK/ g sorbent) | 0.00518                   | 0.00928              | 0.00512           |
| Breakthrough time <sup>a</sup> (min.)    | 52                        | 116                  | 61                |

a = at breakthrough of MEK at 10% of the feed concentration.

b = BH58-69 was not run under dry conditions.

The MEK sorption results for BH58-25 and activated alumina indicated that when water was present in the VOC-contaminated gas flow, the MEK capacities of both sorbents was reduced due to the competition between water and MEK for surface sites. The capacity of BH58-25 for MEK when moisture was present dropped to one third of its capacity under dry conditions while the capacity of the activated alumina dropped to about one tenth of its dry capacity. Under moist conditions, BH58-25 and the activated alumina demonstrated essentially the same MEK sorption performance at 10 % breakthrough. Examination of the full sorption curves for these sorbents showed that the MEK concentration exiting the sorbent bed increased to above the MEK feed concentration then dropped towards the feed concentration. This behavior was especially apparent for the activated alumina as shown in **Figure 9**. This behavior was probably the result of displacement of the initially adsorbed MEK from the sorbent by the higher concentration of higher polarity water molecules. As equilibrium is approached, it would be expected that the MEK concentration would drop back down to the feed concentration as the more weakly-bound MEK is lost. The shapes of the curves for BH58-25 versus the activated alumina also suggest that MEK was more strongly held by BH58-25. After breakthrough occurred, the MEK concentration rose more slowly and peaked out more gradually for BH58-25 indicating that the MEK was less easily displaced from the sorbent surface by water. The reason for this behavior is not clear since the majority of the surface accessible for adsorption in BH58-25 was attributed to the colloidal alumina portion of the sample.

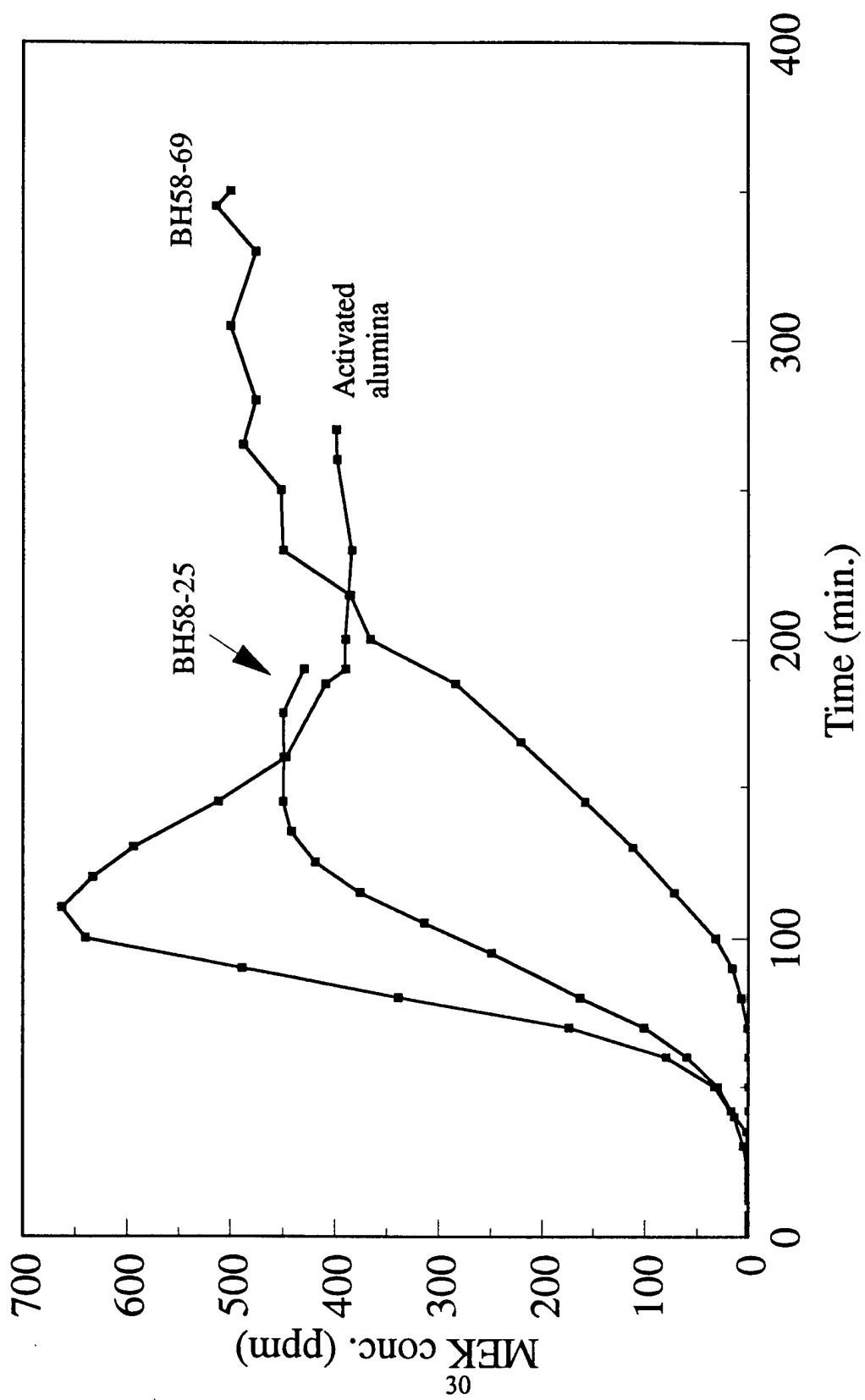

Figure 8. Comparison of MEK sorption curves of BH58-25 and BH58-69 to activated alumina under moist conditions.

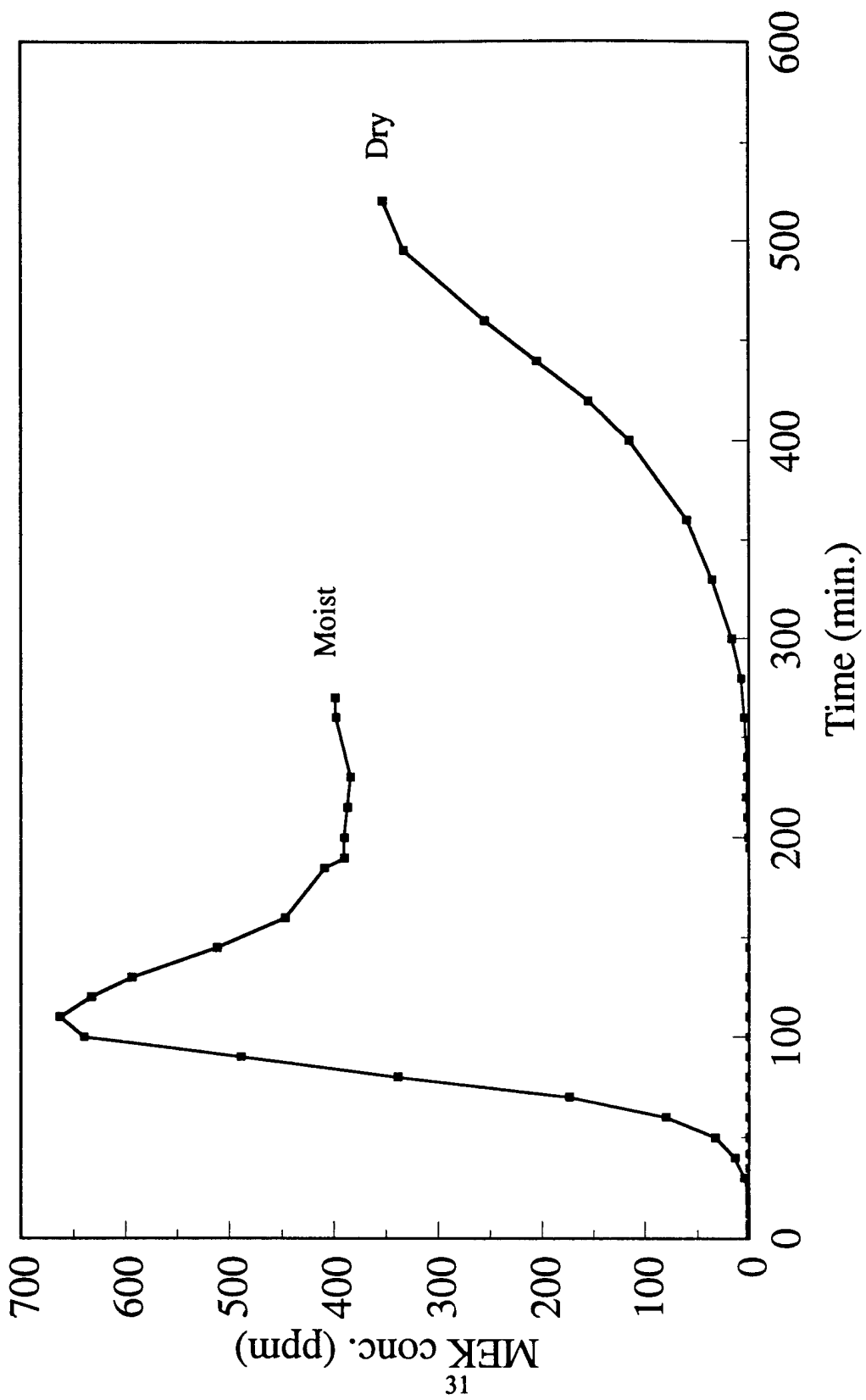

Figure 9. Comparison of MEK sorption capacity of activated alumina under moist and dry conditions.

BH58-69 had nearly double the MEK capacity of the activated alumina under moist conditions even though it had only 75 percent of the surface area of the activated alumina. The characterization carried out on this sample was insufficient to determine the specific reason for this difference. However, the higher capacity of BH58-69 could reflect differences in pore size distribution. A larger portion of the pores in BH58-69 could be of appropriate size for MEK adsorption. A comparison of the pore size distributions for these two samples could be used to verify this theory. Differences in the surface properties between silica and alumina also would be of importance.

b. Activated carbon

Activated carbon is one of the most commonly used sorbents for the control of VOCs, therefore, a sample of commercially available activated carbon was obtained for comparison to the clay based sorbents produced in this project. This material was specifically produced for VOC control use. Its characteristics are shown in Table 9. Due to the activated carbon's very high surface area of 1025 m<sup>2</sup>/g, a sample size of 1.0 g was used in the MEK sorption experiment to allow sorbent bed breakthrough in a reasonable time. The MEK sorption behavior of this activated carbon was determined using the usual experimental conditions with moisture present. The MEK sorption curve for activated carbon versus the curves for BH58-69 and activated alumina are shown in Figure 10.

**Table 9.** Comparison of MEK sorption behavior of activated carbon to BH58-69 and activated alumina.

| Sample name                                            | BH58-69            | HPX               | Activated carbon |
|--------------------------------------------------------|--------------------|-------------------|------------------|
| Description                                            | SWy-2 + silica gel | Activated alumina | Activated carbon |
| Sample size (g)                                        | 2.5                | 2.5               | 1.0              |
| Surface area (m <sup>2</sup> /g)                       | 255                | 340               | 1025             |
| MEK feed conc. (ppm)                                   | 342                | 377               | 377              |
| Capacity <sup>a</sup> (g MEK/ g sorbent)               | 0.00928            | 0.00512           | 0.08211          |
| Breakthrough time <sup>a</sup> (min.)                  | 116                | 61                | 298              |
| g MEK / m <sup>2</sup> of surface (x10 <sup>-5</sup> ) | 3.6                | 1.5               | 8.0              |

a = at breakthrough of MEK at 10% of the feed concentration.

The experimental results for the activated carbon compared to BH58-69 showed that the activated carbon's capacity for MEK at 10% breakthrough was nearly nine times that of BH58-69. The greater capacity was not specifically a function of the greater surface area of the activated carbon. Conversion of the results to grams of MEK per square meter of surface showed that over twice as much MEK per square meter of surface was being adsorbed by the activated

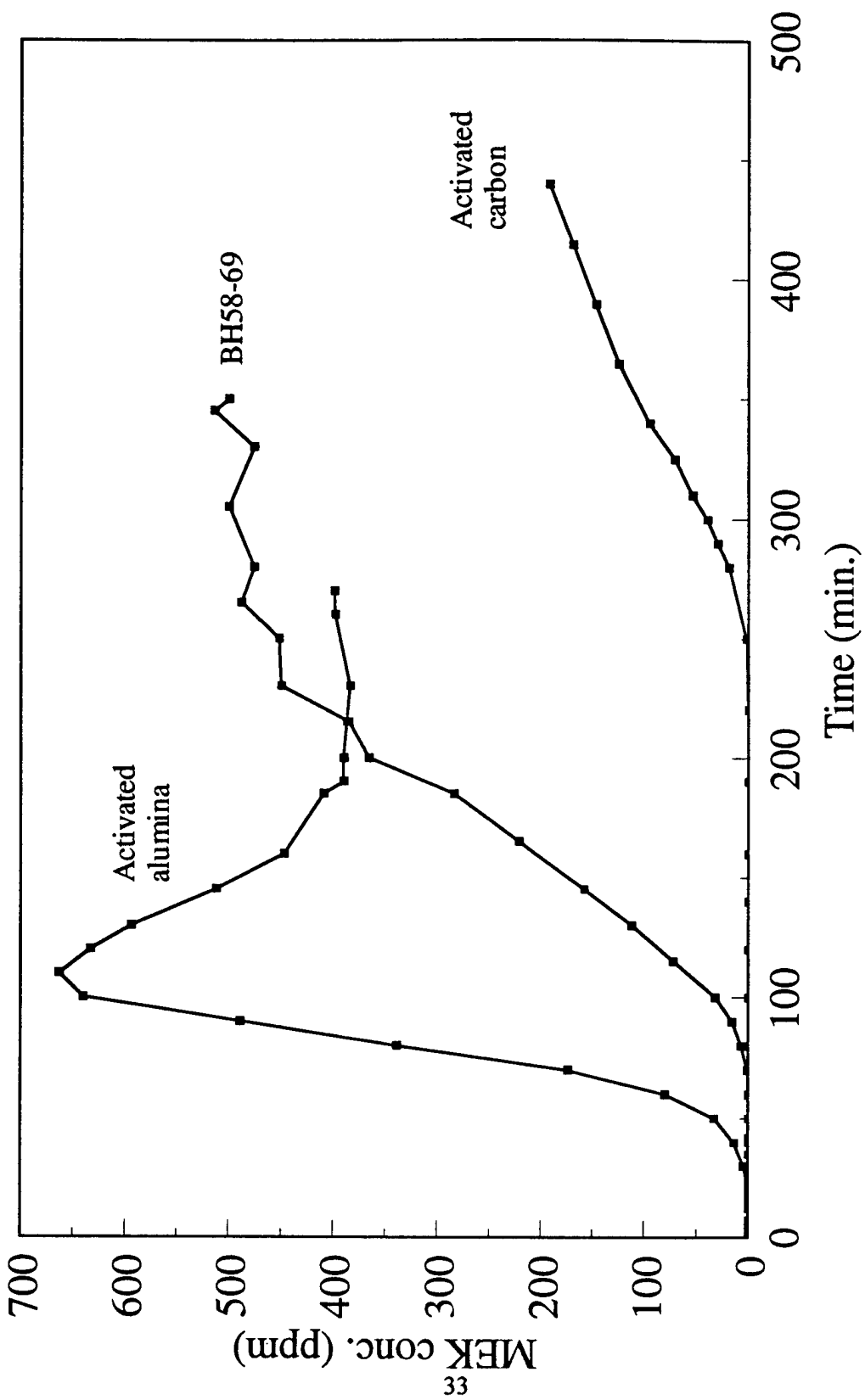

Figure 10. Comparison of MEK sorption curve of activated carbon to BH58-69 and activated alumina under moist conditions.

carbon under the experimental conditions. This difference could reflect pore size distribution effects and/or surface chemistry effects.

Since the VOC capacities of the montmorillonite based sorbents were still much lower than the activated carbon VOC capacity, based on the results obtained using MEK and the estimated cost of producing the montmorillonite-based sorbents studied so far, it was decided that alternative sorbent materials should be considered. The material selected for study was activated char.

## B. Results for Activated Char Sorbents

### 1. Activated Char Pilot 3

NOXSO, in conjunction with ISGS, had previously investigated activated chars for SO<sub>x</sub>/NO<sub>x</sub> control. The sample designated Pilot 3 had been obtained for this purpose. During the search for alternative VOC sorbent materials, Pilot 3 char was also tested. Pilot 3 char was tested for its VOC control potential using MEK as the VOC under moist conditions. Since this sample was developed for a purpose other than VOC control, its VOC capacity was not known, therefore, a 2.50 g sample was used for testing. The resulting MEK sorption curve for Pilot 3 is shown in Figure 11 compared to the commercial activated carbon. Table 10 compares Pilot 3 char to the commercial activated carbon.

**Table 10.** MEK removal results for Pilot 3 activated char and commercial activated carbon under moist conditions.

| Sample name                                            | Pilot 3 char   | Activated carbon |
|--------------------------------------------------------|----------------|------------------|
| Description                                            | Activated char | Activated carbon |
| Sample size (g)                                        | 2.5            | 1.0              |
| Surface area (m <sup>2</sup> /g)                       | 594            | 1025             |
| MEK feed conc. (ppm)                                   | 370            | 377              |
| Capacity <sup>a</sup> (g MEK/ g sorbent)               | 0.0521         | 0.0821           |
| g MEK / m <sup>2</sup> of surface (x10 <sup>-5</sup> ) | 8.8            | 8.0              |

a = at breakthrough of MEK at 10% of the feed concentration.

The results indicated that the Pilot 3 char had an MEK capacity of about two thirds that of the activated carbon on a gram MEK per gram sorbent basis. When the results were adjusted for differences in surface area, Pilot 3 char picked up about 10 percent more MEK per unit of surface. Any effect from differences in sorbent bed depth was not considered for this comparison.

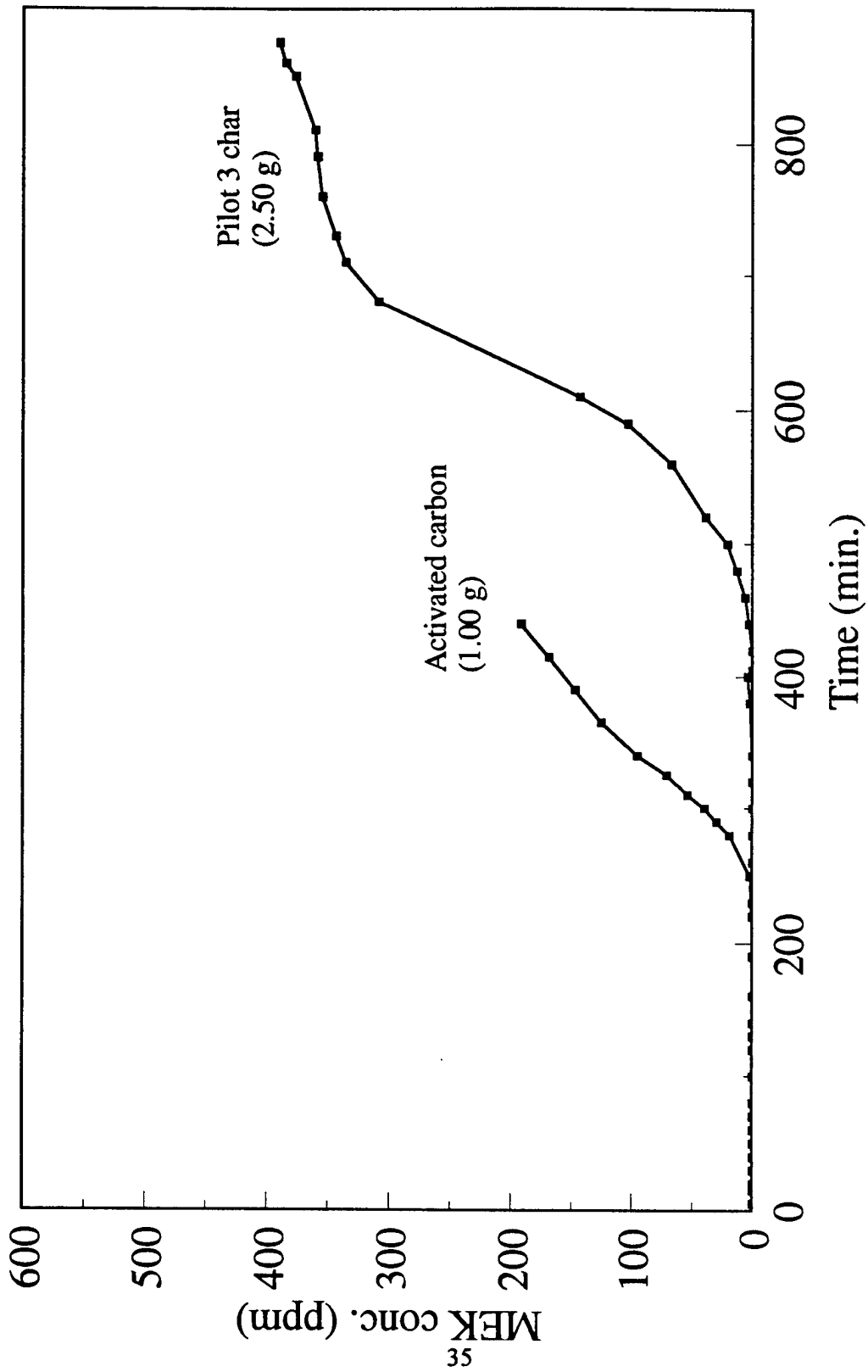

Figure 11. Comparison of MEK sorption curves of Pilot 3 char to activated carbon under moist conditions. The sample size tested is noted.

This result indicated that activated chars had good potential as VOC control sorbents so further experiments were carried out using activated chars.

## 2. Activated Chars for VOC Control

Based on the results obtained for Pilot 3 char, nine samples of activated char were obtained from ISGS for the evaluation of their usefulness in VOC control. These materials were produced by a proprietary method as outlined in the experimental section. **Table 11** lists the char identifications and surface areas measured in NOXSO's laboratory including Pilot 3 char. From these activated chars C, E, F, G, and Pilot 3 #2 were selected for VOC sorption testing. Samples A and B were supplied in insufficient quantity for reactor testing. Samples C, E, and F were supplied in quantities large enough for limited testing. Sample D was a very fine powder and was not suitable for testing in the existing fixed bed reactor.

**Table 11.** Activated chars obtained for VOC control testing.

| Char Identification | Surface area (m <sup>2</sup> /g) | Comment                                        |
|---------------------|----------------------------------|------------------------------------------------|
| A                   | 394                              | Insufficient sample size for testing           |
| B                   | 535                              | Insufficient sample size for testing           |
| C                   | 839                              | Insufficient sample size for extensive testing |
| D                   | NA                               | Powdered sample, not tested                    |
| E                   | 748                              | Insufficient sample size for extensive testing |
| F                   | 94                               | Insufficient sample size for extensive testing |
| G                   | 939                              | Produced to maximize VOC capacity              |
| Pilot 3             | 594                              | Insufficient sample size for extensive testing |
| Pilot 3 #2          | 617                              | Duplicate sample of Pilot 3                    |

NA = not analyzed

### a. MEK sorption tests for activated chars C, E, F, G, and Pilot 3 #2

Activated chars C, E, F, G, and Pilot 3 #2 were tested for their VOC removal capabilities. MEK was used as the model VOC for this comparison. The typical experimental conditions were used. Total gas flow was 250 ml/min with a moisture content of 2.3 percent and a target MEK feed concentration of about 400 ppm. A sample size of 1.00 g was used for all activated char tests. The results of the MEK sorption tests for these activated chars are given in **Table 12** and the sorption curves are shown in **Figure 12**.

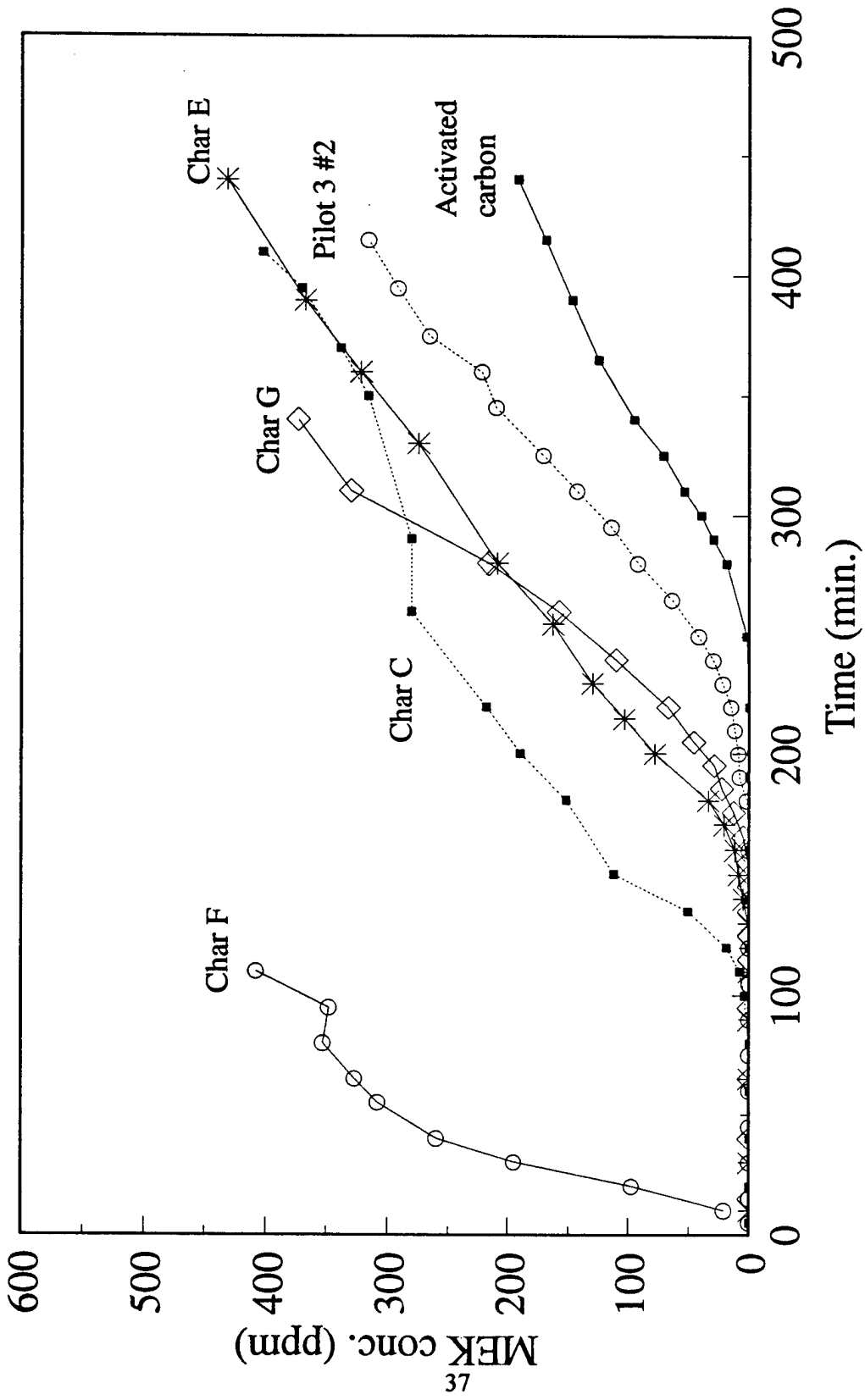

Figure 12. MEK sorption curves of activated chars compared to activated carbon under moist conditions.

**Table 12.** Comparison of MEK removal results for activated chars and commercial activated carbon under moist conditions.

| Sample Identification | Surface area (m <sup>2</sup> /g) | MEK feed conc. (ppm) | Capacity <sup>a</sup> (g MEK/ g sorbent) | Breakthrough time <sup>a</sup> (min.) |
|-----------------------|----------------------------------|----------------------|------------------------------------------|---------------------------------------|
| C                     | 839                              | 397                  | 0.03773                                  | 130                                   |
| E                     | 748                              | 394                  | 0.05235                                  | 182                                   |
| F                     | 94                               | 375                  | 0.00321                                  | 12                                    |
| G                     | 939                              | 438                  | 0.06508                                  | 204                                   |
| Pilot 3 #2            | 617                              | 362                  | 0.06486                                  | 245                                   |
| Activated carbon      | 1025                             | 377                  | 0.08211                                  | 298                                   |

a = at breakthrough of MEK at 10% of the feed concentration.

With the exception of char F, the activated chars performed well for MEK removal under the experimental conditions. Char F had a low surface area and was expected to be a poor sorbent. Char C had a high surface area yet its performance was poorer than predicted. Chars E, G, and Pilot 3 #2 all demonstrated good activities when compared strictly on a gram of MEK collected per gram of sorbent basis, although still not as good as the commercial activated carbon.

Calculation of capacity on a basis of grams of MEK collected per square meter of surface area using the 10 percent breakthrough values was used to take surface area differences into account. These results are given in Table 13. Comparison by this method gives an indication of how well the char's surface was utilized. Using this comparison chars E, G, and Pilot 3 #2 still demonstrated the best performance, however, Pilot 3 #2 surpassed the commercial carbon in surface area utilization. These surface area utilization differences probably reflect the pore size distribution differences between sorbents. A high percentage of micropores, especially those smaller than about 10 Å in diameter, could result in a high surface area as measured using N<sub>2</sub> by the BET method. However, these micropores could be too small to be accessible to MEK molecules or the rate of migration into these pores could be very slow. Based on this effect, char G would be expected to have a higher portion of inaccessible micropores than Pilot 3 #2 since both of these samples collected the same weight of MEK but Pilot 3 #2 had one-third less surface area. However, based on sample availability, char G was selected for further study.

**Table 13.** MEK capacities for activated chars and commercial activated carbon after correction for surface area differences.

| Sample Identification | Surface area (m <sup>2</sup> /g) | Capacity <sup>a</sup> (g MEK/ g sorbent) | g MEK / m <sup>2</sup> of surface (x10 <sup>-5</sup> ) |
|-----------------------|----------------------------------|------------------------------------------|--------------------------------------------------------|
| C                     | 839                              | 0.03773                                  | 4.5                                                    |
| E                     | 748                              | 0.05235                                  | 7.0                                                    |
| F                     | 94                               | 0.00321                                  | 3.4                                                    |
| G                     | 939                              | 0.06508                                  | 6.9                                                    |
| Pilot 3 #2            | 617                              | 0.06486                                  | 10.5                                                   |
| Activated carbon      | 1025                             | 0.08211                                  | 8.0                                                    |

a = at breakthrough of MEK at 10% of the feed concentration.

### 3. Extensive Testing of Char G

Char G was selected from the activated chars tested for MEK adsorption for more extensive testing. This testing included a multiple cycle experiment, and sorption tests using other VOCs. The results of these tests are described in the following sections.

#### a. Multiple cycle test using MEK

Char G was carried through ten sorption/regeneration cycles to determine if it would retain its capacity for MEK. The conditions used for this experiment were the same as described above. Briefly, the sorbent was loaded with MEK under moist conditions until a bed breakthrough of about 10 % of the feed concentration was reached. The sorbent weight was then determined. The sample was then regenerated and cooled under a moist nitrogen flow and weighed again. The same procedure was used for all ten cycles with the exception of cycle 8. The MEK sorption for cycle 8 was carried out dry but the regeneration was done under moist conditions. The sorbent surface area was measured before cycle 1 and after cycle 10. The results are summarized in **Table 14**.

The results show that while there was some variation of the amount of MEK collected in each cycle the activity remained essentially constant through the ten cycles. The starting surface area was 939 m<sup>2</sup>/g. At the end of ten cycles the surface area dropped to 806 m<sup>2</sup>/g. The surface area loss did not affect the MEK capacity at a level detectable by the experiment, therefore, the loss in surface area could probably be attributed to the loss of micropores that are too small for MEK to migrate into. The absence of water in the sorption portion of cycle 8 did not have a significant effect on the MEK capacity of the sorbent for the cycle. This result suggests that the activated char has a stronger affinity for MEK than for water since the amount of MEK collected was about the same under dry and moist conditions.

**Table 14.** Summary of 10 cycle experiment for Char G.

| Cycle | MEK feed conc. (ppm) | Sorbent weight after reaction (g) | Sorbent weight after regeneration (g) | Time (min.) | g MEK / g sorbent |
|-------|----------------------|-----------------------------------|---------------------------------------|-------------|-------------------|
| 1     | 438                  | 1.222                             | 1.042                                 | 204         | 0.065             |
| 2     | 385                  | 1.224                             | 1.013                                 | 224         | 0.064             |
| 3     | 392                  | 1.222                             | 1.006                                 | 220         | 0.063             |
| 4     | 400                  | 1.228                             | 1.013                                 | 236         | 0.069             |
| 5     | 432                  | 1.221                             | 1.005                                 | 233         | 0.071             |
| 6     | 365                  | 1.223                             | 1.017                                 | 244         | 0.066             |
| 7     | 389                  | 1.221                             | 1.014                                 | 218         | 0.062             |
| 8     | 396                  | 1.105                             | 1.009                                 | 261         | 0.076             |
| 9     | 368                  | 1.237                             | 1.007                                 | 239         | 0.065             |
| 10    | 430                  | 1.240                             | 1.024                                 | 221         | 0.07              |

The sorbent weight increase per cycle which was due to MEK and water adsorbed by the sorbent was also reasonably constant through the 10 cycles except for cycle 8. The adsorption portion of cycle 8 was carried out dry which was reflected in the lower weight increase observed. The weight increase for cycle 8 was, consequently, due to only MEK adsorption plus the weight from residue not desorbed during the cycle 7 regeneration, therefore, the weight increase observed should match the amount collected as determined by GC. The weight of MEK determined by direct weighings was 0.088 g and the result from the GC analysis was 0.076 g. These values are in good agreement for this comparison.

The regeneration temperature and heating rate was difficult to control since a manually controlled Variac powering a heating tape was used to heat the reactor. As a result, the maximum temperature reached during regeneration varied from 156 to 189°C. The regeneration curve for cycle 1 is shown in **Figure 13** and was typical of all 10 cycles. However, during regeneration, a large spike of MEK was observed at about 110°C in each cycle. The sample weight following regeneration, shown in **Table 14**, dropped very close to the starting weight of 1.000 g. The slight residual weight excess was probably due to water adsorbed near the end of the cooling cycle since a moist nitrogen stream was used for regeneration and cooling. Precise MEK mass balances for adsorption versus regeneration were not obtainable due to the rate of MEK evolution versus the sampling rate obtainable using the GC and, also, to the MEK spike which was always off scale. However, an estimate of the MEK evolved during regeneration was made using cycles 1,5 and 10 data. The comparison is shown in **Table 15**. Considering that the regeneration amount was low due to the off-scale spike, the values were in reasonable agreement.

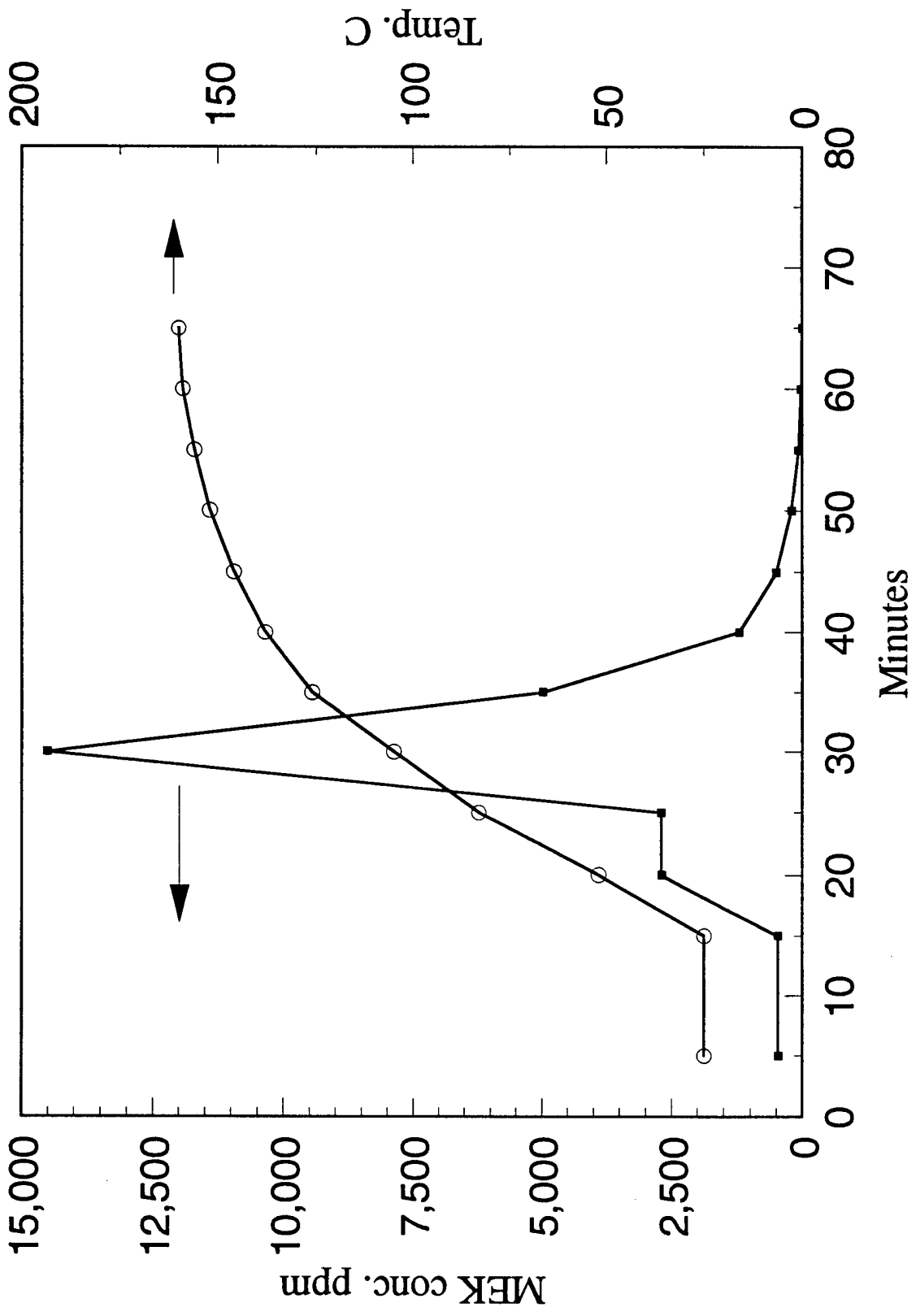

Figure 13. Regeneration curve for char G cycle 1 showing MEK concentration and reactor temperature versus time.

**Table 15.** Comparison of the weight of MEK adsorbed versus the quantity obtained on regeneration derived from GC data.

| Cycle | MEK adsorbed (g) | MEK recovered (g) |
|-------|------------------|-------------------|
| 1     | 0.065            | 0.052             |
| 5     | 0.071            | 0.049             |
| 10    | 0.070            | 0.046             |

b. Char G with other VOCs

Char G was tested for its toluene and trichloroethylene (TCE) removal capability. The following typical conditions were used. The gas stream consisted of nitrogen containing toluene or TCE and 2.3 percent water vapor. The total gas flow rate was 250 ml/min. The target inlet concentration was 400 ppm. However, due to the lower vapor pressures of toluene and TCE, the actual concentrations achieved were slightly lower. Two cycles were carried out for each VOC using fresh sorbent for each VOC. For the first toluene cycle, the concentration was only 155 ppm due to its low vapor pressure. The N<sub>2</sub> flow through the VOC reservoir was increased slightly in cycle 2 to increase the MEK concentration resulting in a concentration of 337 ppm. The total gas flow was adjusted to remain at 250 ml/min. The sorption/regeneration procedure used was the same as that used for MEK. The toluene (2<sup>nd</sup> cycle only), TCE, and MEK sorption curves are shown in Figure 14 and summarized in Table 16 .

**Table 16.** Results of VOC removal by Char G.

| VOC                                         | Toluene |         | TCE     |         | MEK     |         |
|---------------------------------------------|---------|---------|---------|---------|---------|---------|
|                                             | 1       | 2       | 1       | 2       | 1       | 2       |
| Cycle                                       |         |         |         |         |         |         |
| Feed concentration (ppm)                    | 155     | 337     | 350     | 365     | 438     | 385     |
| Time <sup>a</sup> (min)                     | 990     | 669     | 302     | 329     | 204     | 224     |
| VOC collected <sup>a</sup> (g/g sorbent)    | 0.138   | 0.211   | 0.141   | 0.160   | 0.065   | 0.064   |
| VOC collected <sup>a</sup> (mole/g sorbent) | 0.00150 | 0.00224 | 0.00107 | 0.00122 | 0.00090 | 0.00089 |

a = at breakthrough of MEK at 10% of the feed concentration.

The results showed that char G exhibited a greater affinity for toluene and TCE than it did for MEK based on the results, converted to a mole VOC per gram sorbent basis, under the experimental conditions as shown in Figure 14 and Table 16. The order of affinity was toluene > TCE > MEK. This affinity trend is typically observed for activated carbon type sorbents under similar reaction conditions and reflects the strength of the interaction of the organic molecule with the carbon surface as well as the size of the organic molecule<sup>8</sup>. The results obtained for toluene at

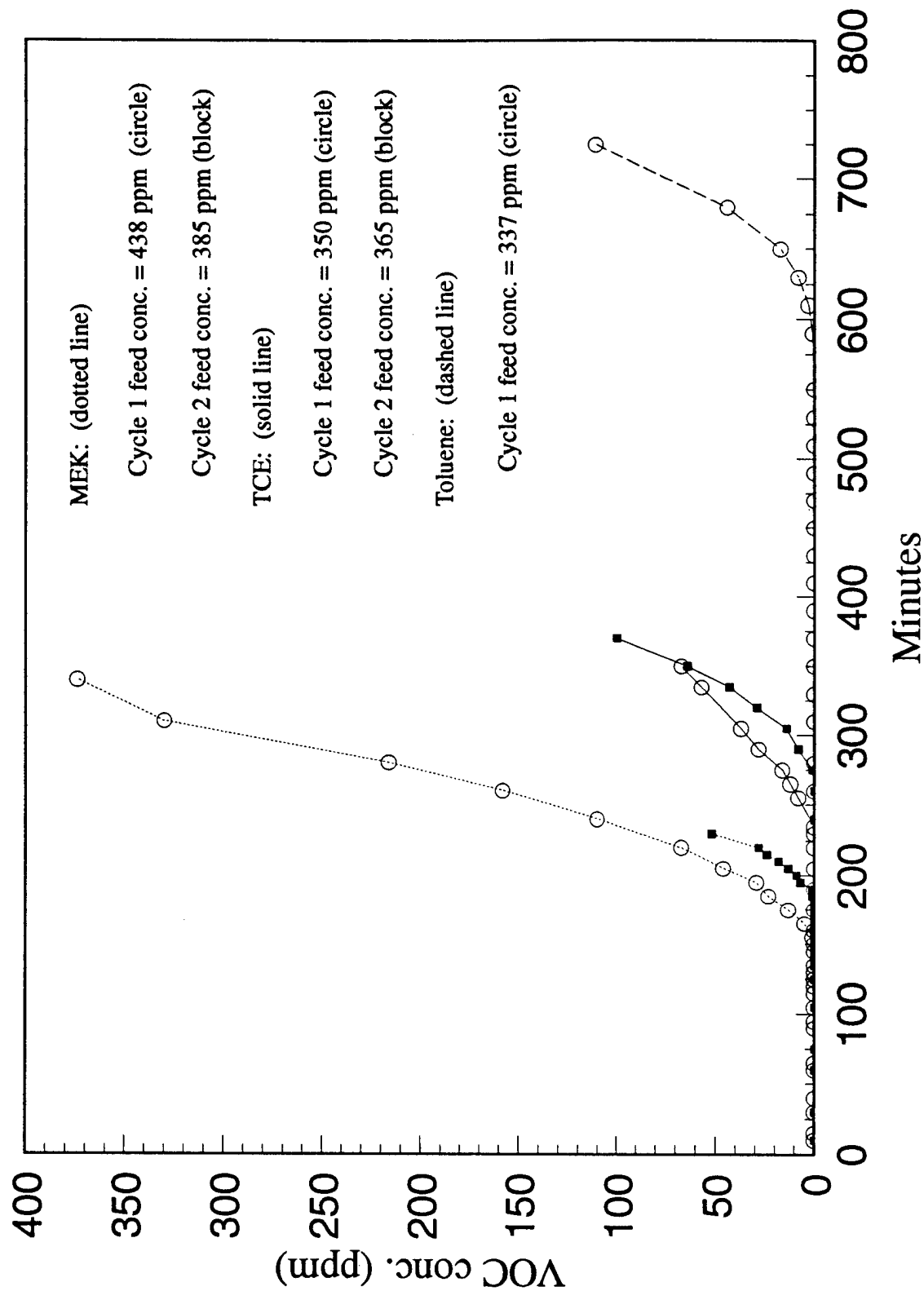

Figure 14. Comparison of MEK, TCE and toluene sorption characteristics for char G.

the different feed concentrations indicated that a higher concentration results in a higher sorbent loading at breakthrough. This result also reflects the trend typically observed for activated carbon sorbents.

### c. Ash content and composition of char G

Since char G was prepared directly from coal with only minimal cleaning to remove impurities it was expected to contain some inorganic mineral residues. The mineral impurity level would be expected to be higher than that of the starting coal since during conversion to char part of the carbonaceous portion would be volatilized while most of the mineral impurities would remain behind. The inorganic impurity level was determined for char G by a low temperature oxidation procedure. The carbon portion of the sample was burned away leaving a rust red residue. The ash content was found to be 27.04 percent by this procedure. The char G ash as well as the original material were analyzed by XRD.

The XRD results for char G indicated that this material consisted of poorly crystalline carbon with a large amount of crystalline material. The crystalline material was identified as mostly quartz ( $\text{SiO}_2$ ), magnetite ( $\text{Fe}_3\text{O}_4$ ), and wustite ( $\text{FeO}$ ), however, other materials were present at lower concentrations but not identifiable. The presence of magnetite was verified by testing the sample with a magnet. It was found that a large portion of the sample was attracted by the magnet verifying the presence of the magnetite. In addition, a qualitative energy dispersive x-ray analysis (EDS) was done on char G to determine the major elements present. The EDS analysis showed significant amounts of carbon, iron, silicon, oxygen, sulfur, aluminum, and potassium. The carbon was attributed to the char while the other elements were attributed to the impurities.

The XRD results for the char G ash verified that the carbon was burned away. The ash consisted primarily of quartz, hematite ( $\text{Fe}_2\text{O}_3$ ), and magnetite. Other crystalline phases were present but not identifiable. The appearance of a large amount of hematite was due to the oxidation of the  $\text{Fe}^{2+}$  in the magnetite and/or wustite present in the original material to  $\text{Fe}^{3+}$ . The rust red color of the ash was due to its high hematite content. The ash was also attracted to a magnet verifying the presence of magnetite.

The behavior observed during the experiments carried out with Char G suggest that it will perform in a similar manner to a typical activated carbon for VOC control. However, the high mineral content of char G and especially the high proportion of iron-based impurity phases could make activated chars poor candidates for halogenated VOC control applications. Regeneration would typically be carried out in the presence of moisture, either from steam regeneration or simply the water adsorbed during use. Transition metal impurities, iron in this case, are known to catalyze the decomposition of some halogenated solvents at elevated temperature in the presence of water resulting in corrosive byproducts such as hydrochloric acid or chloroalcohols.<sup>9</sup>

**These corrosive compounds can lead to much shortened equipment lifetimes and the associated increase in equipment costs. This problem could limit the application of activated chars to nonhalogenated VOC control.**

## SECTION V

### CONCLUSIONS AND RECOMMENDATIONS

#### A. Montmorillonite-based Sorbents

Several montmorillonite-based sorbents were prepared and evaluated during this project. These sorbents were divided into two categories. Alkylammonium pillared montmorillonites and inorganically modified montmorillonites. These sorbents were characterized and tested for their VOC control potential using MEK as the model VOC under moisture free conditions.

The alkylammonium pillared montmorillonites were found to have very low MEK capacities as was predicted based on their low surface areas. XRD, however, indicated that the clay layers were separated by the alkylammonium cations during the exchange process. It was concluded that the alkylammonium cations were exchanged between the clay layers but occupied essentially all of the interlayer volume resulting in an increased layer separation but low surface area. These sorbents could be viewed as stacks of alternating clay layers and alkylammonium layers.

Using organic species to prepare pillared montmorillonite sorbents having high affinity for VOCs is believed to have potential despite the poor performance obtained for them in this study. A possible method for improving performance consists of identifying an organic pillaring species which possesses enough rigidity to hold the clay layers apart without occupying all of the interlayer volume. Research on these materials will continue in this direction.

Inorganically modified montmorillonites showed improvements in their MEK capacities versus the alkylammonium exchanged montmorillonites in two cases. Three methods of inorganic modification were used. Two were based on literature methods for pillaring montmorillonites. The first approach was pillaring with positively charged colloidal alumina and the second was pillaring with  $Al_{13}$  Keggin ions. A third montmorillonite based sorbent was prepared which was a montmorillonite-silica gel composite rather than a pillared clay.

Montmorillonite exchanged with colloidal alumina resulted in an improvement in MEK capacity both with and without subsequent TNBA addition. The cause for the increased capacity was found to be primarily due to the high surface area of the colloidal alumina itself. The clay portion of these sorbents did not significantly contribute to capacity. TNBA addition resulted in increased layer separation of the clay but also reduced capacity by occupying surface sites preventing the adsorption of MEK. Pillaring with  $Al_{13}$  Keggin ions resulted in a surface area increase up to  $184 \text{ m}^2/\text{g}$  and a clay layer separation of about  $6 \text{ \AA}$  but the MEK capacity was very low because the pore diameter was too small to allow easy entry of MEK molecules. The montmorillonite-silica gel composite sorbent had the highest surface area and also the highest MEK capacity of the montmorillonite-based sorbents. Results suggested that this high capacity

was due mostly to the porosity of the silica gel portion of the sorbent although clay layer disorder probably provided a contribution.

The montmorillonite-silica gel composite sorbent had the highest capacity for MEK of the montmorillonite-based sorbents, however, its capacity was still much lower than the commercial activated carbon. This approach for producing a high surface area montmorillonite-based sorbent appears to have some potential, although, more development is necessary. Cost would be a significant drawback for this material since a large percentage of the final product was derived from tetraethoxysilane. Tetraethoxysilane, while available in bulk, is too high priced to allow it to be used to produce an economically viable VOC sorbent. Methods are being pursued to produce this sorbent more cheaply.

## **B. Activated Chars**

Activated chars were identified as having potential as VOC control sorbents. Several activated chars were obtained from Illinois State Geological Survey for testing. These materials were produced directly from coal by a proprietary process. The estimated cost of these activated chars is roughly ten percent of that of commercially produced activated carbons. These materials were tested using MEK as the model VOC under humid conditions and several samples were found to have high capacities approaching that of commercial activated carbon. Of these, one sample was subjected to more thorough testing. It was subjected to ten sorption/regeneration cycles using MEK and found to retain high activity. It was also subjected to two sorption/regeneration cycles for both trichloroethylene and toluene and found to perform well for both of these VOCs. Activated chars were found to have characteristics that would allow them to be used in similar VOC control applications as activated carbons. Experimental results indicated that activated chars could be considered to be low purity activated carbon.

A possible drawback for activated chars, however, is their high mineral impurity content. The sample tested contained over 25 % ash. The mineral impurities were found to be mostly quartz and iron compounds. The presence of a high level of iron, however, could be detrimental to the application of activated char in halogenated solvent control. Under regeneration conditions iron impurities could catalyze the production of corrosive byproducts which would lead to accelerated degradation of VOC control equipment. However, this potential problem has not yet been shown to occur with these activated chars.

As a result of the favorable performance demonstrated by activated chars in this study and their estimated low cost, continued study is recommended. Experiments should be conducted to investigate the potential problems of the high impurity level, especially with regards to halogenated solvent control. Also, further study of the economics of their large scale production is needed.

## REFERENCES

1. Freeman, H.M., Industrial Pollution Prevention Handbook, McGraw-Hill, New York, NY, 1995, p. 384.
2. Barrer, R. M., and Millington, A. D., J. Colloid and Inter. Sci., Vol. 25, 1967, p. 359.
3. Barrer, R. M., Phil. Trans. R. Soc. London, Ser. A, Vol. 311, 1984, p. 333.
4. Van Olphen, H., Fripiat, J. J., Eds., Data Handbook for Clay Minerals and Other Non-Metallic Minerals, Pergamon Press, New York, NY, 1979, p. 19.
5. Howard, B. H., The Hydrodesulfurization of Thiophene by Mo/Co Treated Oxyaluminum Pillared Montmorillonites, PhD Dissertation, Virginia Polytechnic Institute and State University, 1990, p. 112.
6. Brindley, G. W., Sempels, R. E., Clay minerals, Vol. 12, 1977, p. 229.
7. Pinnavaia, T. J., Synthesis of Microporous Materials, Vol. 2, Van Nostrand Reinhold, New York, NY, 1992, p. 1.
8. Kenson, R. E., Environmental Progress, Vol. 4, 1985, p.161.