

**REPORT DOCUMENTATION PAGE**Form Approved  
OMB No. 074-0188

Public reporting burden for this collection of information is estimated to average 1 hour per response, including the time for reviewing instructions, searching existing data sources, gathering and maintaining the data needed, and completing and reviewing this collection of information. Send comments regarding this burden estimate or any other aspect of this collection of information, including suggestions for reducing this burden to Washington Headquarters Services, Directorate for Information Operations and Reports, 1215 Jefferson Davis Highway, Suite 1204, Arlington, VA 22202-4302, and to the Office of Management and Budget, Paperwork Reduction Project (0704-0188), Washington, DC 20503

<b>1. AGENCY USE ONLY (Leave blank)</b>		<b>2. REPORT DATE</b> December 1994	<b>3. REPORT TYPE AND DATES COVERED</b> Final report, vol. I, December 1994	
<b>4. TITLE AND SUBTITLE</b> Information Support for Environmental Management, Legacy Data Capture, and Data Assessment			<b>5. FUNDING NUMBERS</b> US Army Corps of Engineers Cooperative Agreement # DACA76-93-2-0001	
<b>6. AUTHOR(S)</b> Coalition for International Environmental Research and Assistance				
<b>7. PERFORMING ORGANIZATION NAME(S) AND ADDRESS(ES)</b> Coalition for International Environmental Research and Assistance 12529 White Drive Fairfax, VA 22030			<b>8. PERFORMING ORGANIZATION REPORT NUMBER</b> ISEM Final Report, Vol. I CIERA/TEC PSL-94/74	
<b>9. SPONSORING / MONITORING AGENCY NAME(S) AND ADDRESS(ES)</b> SERDP 901 North Stuart St. Suite 303 Arlington, VA 22203			<b>10. SPONSORING / MONITORING AGENCY REPORT NUMBER</b> N/A	
<b>11. SUPPLEMENTARY NOTES</b> Prepared for the Strategic Environmental Research and Development Program Office. This work was supported in part by the US Army Corps of Engineers under Cooperative Agreement # DACA76-93-2-0001. The United States Government has a royalty-free license throughout the world in all copyrightable material contained herein. All other rights are reserved by the copyright owner.				
<b>12a. DISTRIBUTION / AVAILABILITY STATEMENT</b> Approved for public release: distribution is unlimited			<b>12b. DISTRIBUTION CODE</b> A	
<b>13. ABSTRACT (Maximum 200 Words)</b>  Reliable data are difficult to gather in a desert environment due to the extreme spatial and temporal distribution of the resource base. However, the CIERA/TEC team has been able to build on the unique 80-year record of the Jornada Experimental Range (JER). Further, the proximity of the JER to the major military installations of WSMR and Ft. Bliss represents an opportunity for baselining the decision support system in a neighboring system of semi-arid land habitats that has been untouched by military activity, although subjected to a representative set of natural disturbances such as drought, and anthropogenic disturbances such as livestock ranching. Such a baseline provides a foundation for achieving sustainability, because it produces a standard by which a manager may: <ul style="list-style-type: none"> <li>• monitor change over an ecological time frame;</li> <li>• spatially position (georeference) fragmented data sets;</li> <li>• connect fragmented data sets in a time series that represents change;</li> <li>• prioritize research necessary to fill in critical gaps in data with either new data or well-founded theory; and</li> <li>• develop an effective monitoring system to sense ecosystem change over an appropriate time scale.</li> </ul>				
<b>14. SUBJECT TERMS</b> JER, Environmental Management, Legacy Data Capture, Data Assessment, SERDP			<b>15. NUMBER OF PAGES</b> 277	
			<b>16. PRICE CODE</b> N/A	
<b>17. SECURITY CLASSIFICATION OF REPORT</b> unclass	<b>18. SECURITY CLASSIFICATION OF THIS PAGE</b> unclass	<b>19. SECURITY CLASSIFICATION OF ABSTRACT</b> unclass	<b>20. LIMITATION OF ABSTRACT</b> UL	

NSN 7540-01-280-5500

Standard Form 298 (Rev. 2-89)  
Prescribed by ANSI Std. Z39-18  
298-102

DTIC QUALITY INSPECTED 1 19980817 151

764-9211 JEST

26A - 1994

*Global sustainability through  
innovative environmental technologies*

**Final Report  
Volume I**



**Information Support for  
Environmental Management, Legacy  
Data Capture, and Data Assessment**

December, 1994

*Prepared for the*

**Strategic Environmental Research and Development Program Office**

901 North Stuart Street, Suite 303

Arlington, Virginia 22203

Under US Army Corps of Engineers

Cooperative Agreement # DACA76-93-2-0001

*Submitted by the*

***Coalition for International Environmental Research and Assistance***

12529 White Drive, Fairfax, Virginia 22030

Telephone (703) 815-0245, Fax (703) 968-6614



**Information Support for  
Environmental Management,  
Legacy Data Capture, and Data Assessment**

**Final Report: Volume I**

December, 1994

*Prepared for the*

**Strategic Environmental Research and Development Program Office**

901 North Stuart Street, Suite 303

Arlington, Virginia 22203

Under US Army Corps of Engineers

Cooperative Agreement # DACA76-93-2-0001

*Submitted by the*

***Coalition for International Environmental Research and Assistance***

*12529 White Drive, Fairfax, Virginia 22030*

*Telephone (703) 815-0245, Fax (703) 968-6614*



## CONTENTS

Section	Page
<b>FIGURES</b> .....	ix
<b>TABLES</b> .....	ix
<b>1.0 Introduction</b> .....	1
<b>2.0 Background</b> .....	5
<b>3.0 Objectives</b> .....	7
<b>4.0 Approach</b> .....	9
4.1 <u>Jornada Experimental Range Legacy Data</u> .....	11
4.1.1 System Description .....	11
4.1.2 Procedures .....	13
4.1.2.1 <i>Data Scanning</i> .....	13
4.1.2.2 <i>Quadrat Annotation</i> .....	15
4.1.2.3 <i>Indexing</i> .....	17
4.1.2.4 <i>Contour Vectorization</i> .....	18
4.1.2.5 <i>Data Archive</i> .....	20
4.1.2.6 <i>Data Browser</i> .....	22
4.1.2.7 <i>Quadrat Visualization</i> .....	24
4.1.2.8 <i>Data Set Verification</i> .....	24
4.1.2.9 <i>Statistical Analysis</i> .....	26
4.1.2.10 <i>GIS Import Methods</i> .....	29
4.1.2.10.1 <i>Quadrat Import</i> .....	29
4.1.2.10.2 <i>Precipitation Data Import</i> .....	30
4.1.2.10.3 <i>Grazing Data Import</i> .....	32
4.1.2.10.4 <i>Digital Elevation Model Data</i> .....	33
4.1.2.11 <i>Image Processing</i> .....	33
4.1.2.11.1 <i>Land Use/Land Cover Maps</i> .....	35
4.1.2.11.2 <i>Spectral Vegetation Indices</i> .....	37
4.1.2.11.3 <i>Change Detection</i> .....	38
4.1.2.11.4 <i>Image Data Merging</i> .....	38
4.2 <u>Geographic Information System Backgrounds</u> .....	40
4.2.1 System Description .....	40
4.2.2 Procedures .....	41
4.2.2.1 <i>Quadrat Geopositioning</i> .....	42

4.2.2.2	<i>Data Set Incorporation into GIS</i>	43
4.3	<u>Simulation/Model Investigation</u>	44
4.3.1	Procedures	44
4.3.2	Model Descriptions	44
4.3.2.1	<i>GEPSI</i>	44
4.3.2.2	<i>MONOMOD/MIXMOD</i>	45
4.3.2.3	<i>SERECO</i>	45
4.4	<u>Ontology of Habitat Classifications of Jornada Data</u>	46
4.4.1	Procedures	46
4.5	<u>Conceptual Framework for Arid-Land Characterization</u>	48
4.5.1	Field Mapping System	48
4.5.1.1	<i>System Description</i>	48
4.5.1.2	<i>Procedures</i>	48
4.5.2	Interpolation/Extrapolation Approaches	49
4.5.2.1	<i>Introduction</i>	49
4.5.2.2	<i>Scale</i>	49
4.5.2.3	<i>Flows and Cycles</i>	51
4.5.2.4	<i>Ecology Studies</i>	54
4.5.2.5	<i>Ecological Concepts</i>	55
4.5.2.5.1	Direct and Indirect Effects	55
4.5.2.5.2	Island Biogeography	56
4.5.2.5.3	Succession	56
4.5.2.5.4	Coevolution	56
4.5.2.5.5	Stability and Biodiversity	57
4.5.2.6	<i>Modeling</i>	57
4.5.2.6.1	Biogeochemical Plant Growth Model	57
4.5.2.6.2	Community Food Web Model	60
4.5.2.6.3	Compartmental Growth Model	61
4.5.2.7	<i>Biogeographic Classification and Artificial Ecosystem Simulation</i>	62
4.5.2.7.1	Introduction	62
4.5.2.7.2	System Description	63
4.5.2.7.3	Procedures	66
4.5.2.8	<i>Remote Sensing and Stochastic Landscape Simulation</i>	67
4.5.2.8.1	Introduction	67
4.5.2.8.2	Procedures	68
4.5.3	GIS Products	69
4.5.3.1	<i>Procedures</i>	70
4.5.4	Ft. Bliss and White Sands Missile Range Data	70
4.5.4.1	<i>Procedures</i>	70
4.6	<u>Applicability Study of FALCON Workstation</u>	72
4.6.1	System Description	73

4.6.1.1	<i>FALCON System Components</i>	73
4.6.1.1.1	AIMS	74
4.6.1.1.2	COOP	74
4.6.1.1.3	SAS	76
<b>5.0</b>	<b>Results and Discussion</b>	<b>79</b>
5.1	<u>Jornada Experimental Range Legacy Data</u>	79
5.1.1	Data Scanning	79
5.1.2	Quadrat Annotation	79
5.1.3	Indexing	79
5.1.4	Contour Vectorization	80
5.1.5	Data Archive	80
5.1.6	Data Browser	80
5.1.7	Quadrat Visualization	80
5.1.8	Data Set Verification	81
5.1.9	Statistical Analysis	81
5.1.10	GIS Import	81
5.1.10.1	<i>Quadrat Import</i>	81
5.1.10.2	<i>Precipitation Data Import</i>	81
5.1.10.3	<i>Grazing Data Import</i>	82
5.1.10.4	<i>Digital Elevation Model Data</i>	82
5.1.11	Image Processing	82
5.1.11.1	<i>Land Use/Land Cover Maps</i>	82
5.1.11.1.1	Unsupervised Classification	82
5.1.11.1.2	Supervised Classification	82
5.1.11.2	<i>Spectral Vegetation Indices</i>	83
5.1.11.3	<i>Change Detection</i>	83
5.1.11.4	<i>Image Data Merging</i>	83
5.2	<u>Geographic Information System Backgrounds</u>	84
5.3	<u>Simulation/Model Investigation</u>	85
5.3.1	GEPSI	85
5.3.1.1	<i>Environment</i>	86
5.3.1.1.1	Weather Class	86
5.3.1.1.2	Microweather Class	87
5.3.1.1.3	Soil Class	87
5.3.1.2	<i>Plant</i>	87
5.3.1.2.1	Plant Class	87
5.3.1.2.2	Stem Class	87
5.3.1.2.3	Leaf Class	88
5.3.1.2.4	Canopy Class	88
5.3.1.2.5	Rootsystem Class	89

5.3.1.2.6	Root Class	89
5.3.2	MONOMOD/MIXMOD	89
5.3.3	SERECO	89
5.4	<u>Ontology of Habitat Classifications of Jornada Data</u>	91
5.5	<u>Conceptual Framework for Arid-Land Characterization</u>	92
5.5.1	Field Mapping System	92
5.5.2	Interpolation/Extrapolation Approaches	92
5.5.2.1	<i>Proposed Self-Learning Approach to Modeling</i>	92
5.5.2.2	<i>The Landscape Prediction Problem</i>	96
5.5.2.2.1	Deterministic Patterning	96
5.5.2.2.2	Stochastic Nonlinear Dynamics	97
5.5.2.2.3	Scaling Effects and Prediction	98
5.5.2.2.4	Qualities of Ecosystem Dynamics	99
5.5.2.2.5	Model: Prediction Change by Evolving Trajectories	102
5.5.3	Geographic Information System Products	102
5.5.4	Applicability Study of FALCON Workstation	102
5.5.4.1	<i>Integrated Environmental Management System</i>	102
5.5.4.1.1	Background Environmental Database	104
5.5.4.1.2	Data Fusion	104
5.5.4.1.3	Remote Communications Access	105
5.5.4.1.4	Environmental Modeling Capability	105
5.5.4.1.5	Hardware/Software System	106
6.0	<b>Summary and Conclusions</b>	109
6.1	<u>Legacy Data Capture</u>	109
6.2	<u>Analytic Frameworks for Habitat Characterization</u>	109
6.3	<u>Prototype Data Fusion Techniques</u>	110
6.4	<u>FALCON Workstation Support System</u>	111
7.0	<b>Future Work</b>	113
8.0	<b>GLOSSARY</b>	117
	<b>APPENDIX A, SAMPLE QUADRAT ANNOTATION LIST</b>	A-1
	<b>APPENDIX B, REFERENCES</b>	B-1
	<b>APPENDIX C, MASTER BOTANICAL LIST</b>	C-1
	<b>APPENDIX D, LATIN LIST</b>	D-1

**APPENDIX E, IMAGES LIST . . . . . E-1**

**APPENDIX F, GEOPOSITIONED AUGMENTED, ANNOTATED QUADRAT  
DATA . . . . . F-1**

**APPENDIX G, STATISTICAL PLOTS . . . . . G-1**

**APPENDIX H, SOURCE CODE . . . . . H-1**

**APPENDIX I, GIS BACKGROUND DATA . . . . . I-1**

**APPENDIX J, HABITAT CLASSIFICATIONS . . . . . J-1**

**APPENDIX K, MAPS AND IMAGES . . . . . K-1**



## FIGURES

Figure	Page
Figure 1. JDR System Main GUI . . . . .	12
Figure 2. Scan GUI . . . . .	14
Figure 3. Annotation GUI . . . . .	16
Figure 4. Image Processing GUI . . . . .	19
Figure 5. Archive Quadrat Data GUI . . . . .	21
Figure 6. Archive Browser GUI . . . . .	23
Figure 7. Quadrat Visualization GUI . . . . .	26
Figure 8. Statistical GUI . . . . .	28
Figure 9. Environmental Management Workstation . . . . .	41
Figure 10. Time-Space Diagram . . . . .	50
Figure 11. Generalized Static Model of Energy/Element Flows & Cycles In Ecosystems . . . . .	52
Figure 12. Flow Diagram, Intertidal Oyster Reef . . . . .	53
Figure 13. Whole Plant Growth Model . . . . .	58
Figure 14. Algorithm for Optimization used in the Growth Model . . . . .	62
Figure 15. Ontology Construction Stages . . . . .	64
Figure 16. Modeling Process . . . . .	65
Figure 17. Patch Mosaic Landscapes . . . . .	68
Figure 18. Flow of Environmental Data in a FALCON-Like Integrated System Structure . . . . .	73
Figure 19. Example: Landscape Encoding . . . . .	93

## TABLES

Table	Page
Table 1. Phase I Objectives . . . . .	10
Table 2. IEMS Requirement Description/Corresponding FALCON Features . . . . .	108



## 1.0 Introduction

This document reports the progress of each activity associated with the Legacy Data Capture and Data Assessment (Phase I) of the Information Support for Environmental Management Project, U.S. Army Corps of Engineers Cooperative Agreement #DACA76-93-2-0001. This project was a collaborative effort between two organizations:

- U.S. Army Topographic Engineering Center (TEC)  
Environmental Sciences Division  
7701 Telegraph Road  
Alexandria, VA 22315-3864  
Tel (703) 355-2840, Fax (703) 355-3176
- Coalition for International Environmental Research and Assistance (CIERA)  
12529 White Drive  
Fairfax, VA 22030  
Tel (703) 815-0245, Fax (703) 968-6614

CIERA is a non-profit organization with an extensive network of environmental experts in government and non-government organizations; university instruction, research, and outreach programs; business and industry; and trade and professional organizations. Because CIERA has a broad view of both domestic and international environmental activities, it has a unique perspective on cross-cutting environmental issues. As demonstrated in this project, CIERA is well positioned to act as a bridge between organizations with tangent or overlapping activities. Working in cooperation with TEC, CIERA coordinated the activities of work groups both within and between organizations participating on the program, such as the linkages between multiple universities with related research programs and between agencies within the Federal Government.

While internal coordination and mutual information sharing should be the *defacto* standard, organizational barriers often prevent cooperative interaction. CIERA provides unbiased project coordination and conflict resolution that leads to mutually beneficial project management based on long-term effectiveness. CIERA does *not* necessarily "manage" the individual project components, but rather provides a non-partisan forum in which mutual interaction and exchange can take place. The mechanism for this exchange is a *project team*, composed of individuals with diverse backgrounds and expertise working on the same (or related) environmental initiatives. While each may be associated with discrete organizations and projects, their joint participation in the team provides each with a broader, more comprehensive picture of the problem as a whole. Working together, members of the CIERA team are able to integrate their knowledge with that of others, develop a more holistic perspective, and return to their own organizations to share expanded environmental understanding.

The organizational components of the CIERA team included:

- USDA, Agricultural Research Service  
Jornada Experimental Range (JER), New Mexico State University (NMSU)  
Dept. 3JER, NMSU  
Las Cruces, NM 88003  
Tel (505) 646-4842

JER contributed expertise in rangeland ecology and management, provided geopositioned legacy data, developed data sampling schemes, and developed ground-truthed products derived from remote sensing.

- Physical Science Laboratory (PSL), NMSU  
PO Box 30002  
Las Cruces, NM 88003-0002  
Tel (505) 522-9100, Fax (505) 522-9389/9434

PSL developed systems for the capture of historical data, the visualization of landscapes, and the integration of components into a prototype environmental workstation. It also investigated prospects for model-based retrieval of data and images relevant to specific user problems and queries.

- EnviroTech Associates  
304 Roadrunner Parkway, #806  
Las Cruces, NM 88003-0003  
Tel (505) 646-3225, Fax (505) 646-5975

EnviroTech Associates supplied additional ecological knowledge and supported the collection of ground-truth data.

- Ohio University (OU), Research and Graduate Studies  
109 Research Center  
Athens, OH 45701  
Tel (614) 593-0373, Fax (614) 593-0380

OU faculty analyzed ground-collected data provided by JER and other team members

TEC provided expertise in Geographic Information Systems (GIS), image analysis, and portable systems for the collection of imagery data in the field. They also provided additional physical data for the region and assisted in the development of the conceptual framework for characterizing arid-land habitats.

## **1.1 Project Background**

The appropriated funds were managed through TEC through the multi-agency Strategic Environmental Research and Development Program (SERDP). This program was established in 1990 as an alliance between the Department of Defense (DoD), the Department of Energy (DoE), and the Environmental Protection Agency (EPA) to support environmental quality, research development, demonstrations, and applications. The SERDP has six areas of technology thrust: cleanup, compliance, conservation, pollution prevention, global environmental change, and energy conservation/renewable resources.

The Information Support for Environmental Management project was funded through a Congressional appropriation of \$500,000 in FY92 under the Advanced Technology Development: Strategic Environmental Research category (0608716D) of the budget of the Department of Defense. An additional \$250,000 was allocated to TEC by the SERDP Program Office for this project. The funds were appropriated to support CIERA "in developing a comprehensive, open system architecture that supports the detection, monitoring and resolution of environmental problems."

TEC and CIERA made a cooperative decision to focus development within the area of conservation. From an Army perspective, conservation of natural resources has rapidly become critical to the DoD mission. The relatively new understanding that military lands comprise only a fraction of much larger ecosystems compounds the problem that the DoD faces in maintaining plant and animal species within its physical boundaries. The military shares the conservation requirement with many public and private institutions. These institutions are increasingly being regulated for land use, particularly for effects on threatened and endangered species, water and air quality, and soil erosion.

Through NMSU, CIERA was able to access an 80-year record of bio-physical rangeland data from the USDA/ARS JER. Situated on 72,000 hectares of semi-arid rangeland outside of Las Cruces, New Mexico, comprehensive data sets have been collected in many studies (some of which are long-term) of rangeland health under different animal and human stressors. The JER is directly adjacent to DoD installations at White Sands Missile Range (WSMR) and Ft. Bliss. Both of these facilities are undergoing decertification. The JER data promised to shed light on the processes of arid-region degradation, to provide a baseline for habitat conditions in arid land installations free of training impacts, and to suggest methods pertaining to conservation and remediation.

The goal of the completed Phase I, as defined by the TEC Execution Plan of October 8, 1993, was to incorporate decision-making support software with existing databases and other imagery, mapping, and terrain analysis techniques into an environmental manager's decision support system for the management of habitats on DoD and other government-owned lands.

CIERA and TEC recognized that the available funds were inadequate to achieve this goal. The current work, which was conducted in 1994, was intended to be the first phase of a multi-year project, with the ultimate goal of developing an advanced technology applicable to habitat management across diverse environments. Phase I focused primarily on the following tasks:

- Capturing the historical data record from the JER in machine-readable form;
- Assessing the value of this data for baselining the states of semi-arid lands to be taken under ecological management; and
- Evaluating the FALCON intelligence information fusion system model as an architecture for designing environmental data fusion systems.

CIERA recognized that FALCON's strengths were exactly those required by an environmental workstation. FALCON is an advanced data fusion architecture concept developed by the Austin Division of Lockheed Missiles & Space Company, Inc. for application in low-intensity conflict intelligence analysis. Designed on open system principles, FALCON integrates data gathering, situation development, and intelligent autonomous data fusion components into a distributed intelligence analysis network. Guided by the virtues of the falcon bird, the system was intended to enable a small force to "overcome larger prey through clarity of vision, cunning, speed, and surprise." Compared to the forces of nature, a human organization can only apply modest resources to environmental problems. A "green" FALCON would permit the effective planning and application of environmental "countermeasures" by applying advanced intelligence to evolving problems and providing the information to plan a response.

## **1.2 Organization of Volume I of the Final Report**

*Section 2.0* of this document provides the criteria used for the selection of objectives for Phase I of the Information Support for this environmental management project. *Section 3.0* lists the global objectives and goals of the project, as well as those unique to Phase I. *Section 4.0* provides an overview of each activity in Phase I; a description of the hardware, software, and testbeds used for accomplishing the activity, as applicable; and the procedures used to execute the activity. *Section 5.0* details, for each activity, the results obtained from executing the procedures listed in *Section 4.0*. *Section 6.0* provides a summary of the Phase I effort. *Section 7.0* provides a discussion of follow-on activities to be performed for this project. *Section 8.0* is a list of all of the acronyms and abbreviations used in this document. *Appendices A-K* contain information vital to understanding this document.

## **2.0 Background**

Environmental management decisions require: (1) the understanding of ecological processes operating at different spatial and temporal scales, and (2) prediction models to hypothesize alternative future states under different environmental conditions and management actions. Given this foundation, the resource manager would be free to pursue environmental goals by manipulating relevant internal ecosystem controls to maintain or improve water, mineral, and energy cycles.

Achieving resource sustainability is particularly difficult for the military environmental manager, due to the special problem of optimizing support of the military mission while protecting the natural resource. With conservation as one of the primary concerns of the Tri-Service Environmental Quality Research and Development Strategic Plan, understanding of the habitats within the manager's real estate is required in the context of larger ecosystems outside of the DoD physical boundaries. Moreover, to be effective under increasing regulation, the manager's conservation efforts must be coordinated with surrounding public and private land holders.

Conservation is particularly difficult within arid and semi-arid environments. Unfortunately, many of the DoD installations are built on arid lands, including WSMR, which is adjacent to the JER study site. This installation has lost native grassland to intruding shrubs. Other Southwest installations have experienced similar conditions because desert habitats are extremely slow to recover from stress-related degradation. In fact, an increasing number of ecologists who have studied the effects of intensive livestock grazing in the western states are coming to believe that, in many cases, recovery may not be possible at all.

To understand the natural processes that will be affected by the military missions, the environmental manager must begin with basic ecological principles and data demonstrating change over a long period of time. This data must be ecologically relevant, spatially connected, and temporally continuous over relevant space. Habitat data are therefore primary in the decision tool design process, which must be strongly influenced by considerations of data availability, quality, and relevance.

Reliable data are difficult to gather in a desert environment due to the extreme spatial and temporal distribution of the resource base. However, the CIERA/TEC team has been able to build on the unique 80-year record of the JER. Further, the proximity of the JER to the major military installations of WSMR and Ft. Bliss represents an opportunity for baselining the decision support system in a neighboring system of semi-arid land habitats that has been untouched by military activity, although subjected to a representative set of natural disturbances such as drought, and anthropogenic disturbances such as livestock ranching.

Such a baseline provides a foundation for achieving sustainability, because it produces a standard by which a manager may:

- monitor change over an ecological time frame;
- spatially position (georeference) fragmented data sets;
- connect fragmented data sets in a time series that represents change;
- prioritize research necessary to fill in critical gaps in data with either new data or well-founded theory; and
- develop an effective monitoring system to sense ecosystem change over an appropriate time scale.

### 3.0 Objectives

The ultimate objective of the Information Support For Environmental Management project is to develop a decision support workstation for landscape management. The workstation will integrate networked data sources, field data collection capabilities, and habitat situation analysis capabilities into a distributed information management system for both field and laboratory use. This system will provide assistance to land managers, thus providing them with the ability to set management priorities, identify vulnerable habitats, communicate concerns and plans, and respond to unexpected outcomes of management decisions.

All of the above tasks require a land manager to bridge the gap between ecological time (approximately 10 to 100 years) and the performance of human activity. Given a representation of specific ecosystem factors and relationships grounded in real data, a manager must be able to envision possible futures, and to explore methods for moving toward these future states. In general, a manager must be able to:

- represent the variety of natural factors and human interventions in natural cycles that may impact change in the grounded ecosystem;
- develop some spanning set of possible management options that apply to a particular set of sustainability criteria;
- identify and evaluate controls for the modeled sustainable system; and
- identify and evaluate indicators that should be monitored to ensure that particular criteria are reached.

The objectives for Phase I of the project are to:

- establish a sample data set of high quality data derived from the JER holdings for use in the development of situation analyses and management methodologies for deserts;
- identify existing and potential analytical frameworks (models) for characterizing habitats in time and space;
- prototype a basic set of GIS-oriented data fusion approaches for habitat management; and
- review the applicability of the autonomous agent (i.e., FALCON workstation) approach to support the GIS-based data fusion tools.



## 4.0 Approach

The objectives listed in Section 3 for Phase I of the Information Support For Environmental Management project have been achieved by performing the following activities.

1. Capture a sample set of JER data in machine-readable form. These data provide the foundation for the development of habitat and disturbance analysis metrics, algorithms, and methodologies.
2. Capture background data, such as rainfall for the range, generalized soil data, detailed vegetation records for 1928 and 1963, pasture maps, pasture histories, and roads/trails within a GIS. These data support habitat interpolation and extrapolation.
3. Compile an inventory of the production-oriented and non-production process models generated by the USDA/ARS's rangeland research program. This inventory will be used to evaluate relevant models for possible inclusion in a decision support system.
4. Organize into an ontology a sample set of habitat classifications for the Jornada region. Report on the metrics used to classify environmental structure, methods of application, and typical values.
5. Provide data fusion, interpolation, and extrapolation approaches that integrate habitat data in time and space, along with GIS products resulting from simulated algorithm runs.
6. Report on the possible applicability of the FALCON workstation approach to building an evidence and pattern analysis GIS layer to automate habitat analysis. These software agents are mental extensions of the analyst in that they automatically act on the analyst's behalf. Some of these agents are always active in the analysis process, while others are situation-activated.

Table 1 cross-references the Phase I objectives with the activities that facilitated their completion.

**Table 1. Phase I Objectives**

Objective	Activities
Establish a sample data set of high quality data derived from the Jornada holdings for use in the development of semi-arid land ecological situation analysis and management methodologies.	1. Jornada Experimental Range Legacy Data
Identify existing and potential analytical frameworks for characterizing habitats in time and space.	2. Geographic Information System Backgrounds 3. Simulation/Model Investigation 4. Ontology of Habitat Classifications of Jornada Data
Prototype a basic set of GIS-oriented data fusion approaches for habitat management.	5. Conceptual Framework for Arid-Land Characterization
Review the applicability of the autonomous agent (i.e., FALCON workstation) approach to supporting the GIS-based data fusion tools.	6. Applicability Study of FALCON Workstation

## **4.1 Jornada Experimental Range Legacy Data**

A portion of the legacy data available from the JER is in the form of 103 pantographed/planimetered, one-meter-square quadrats. These data consist of plant basal area contour outlines on graph paper with their accompanying annotations and summation addendum. These data have been collected on a yearly basis at selected sites on the JER from 1915 to 1980. This information record, along with additional data such as yearly rain gauge measurements, provides a unique opportunity to study environmental changes and causal effects related to the desertification of arid rangelands.

The JER quadrat set consists of approximately 7000 planimetered quadrat maps. The scope of this study was to capture over 700 maps from 13 quadrats for the southwest portion of the JER. These quadrats were geopositioned for future use utilizing the GIS procedures outlined in Section 4.2.

### **4.1.1 System Description**

The Jornada Data Rescue (JDR) system was developed in order to provide an easy and consistent method to capture and archive the legacy data. This system consists of a Personal Computer (PC)-based workstation, a scanner, and software to provide a Graphical User Interface (GUI) to the system user for the data capture and store. The interface minimizes data entry errors, because the user does not enter any information concerning the quadrats, but rather uses a mouse to choose from predefined selections. The JDR Main GUI is shown in Figure 1.

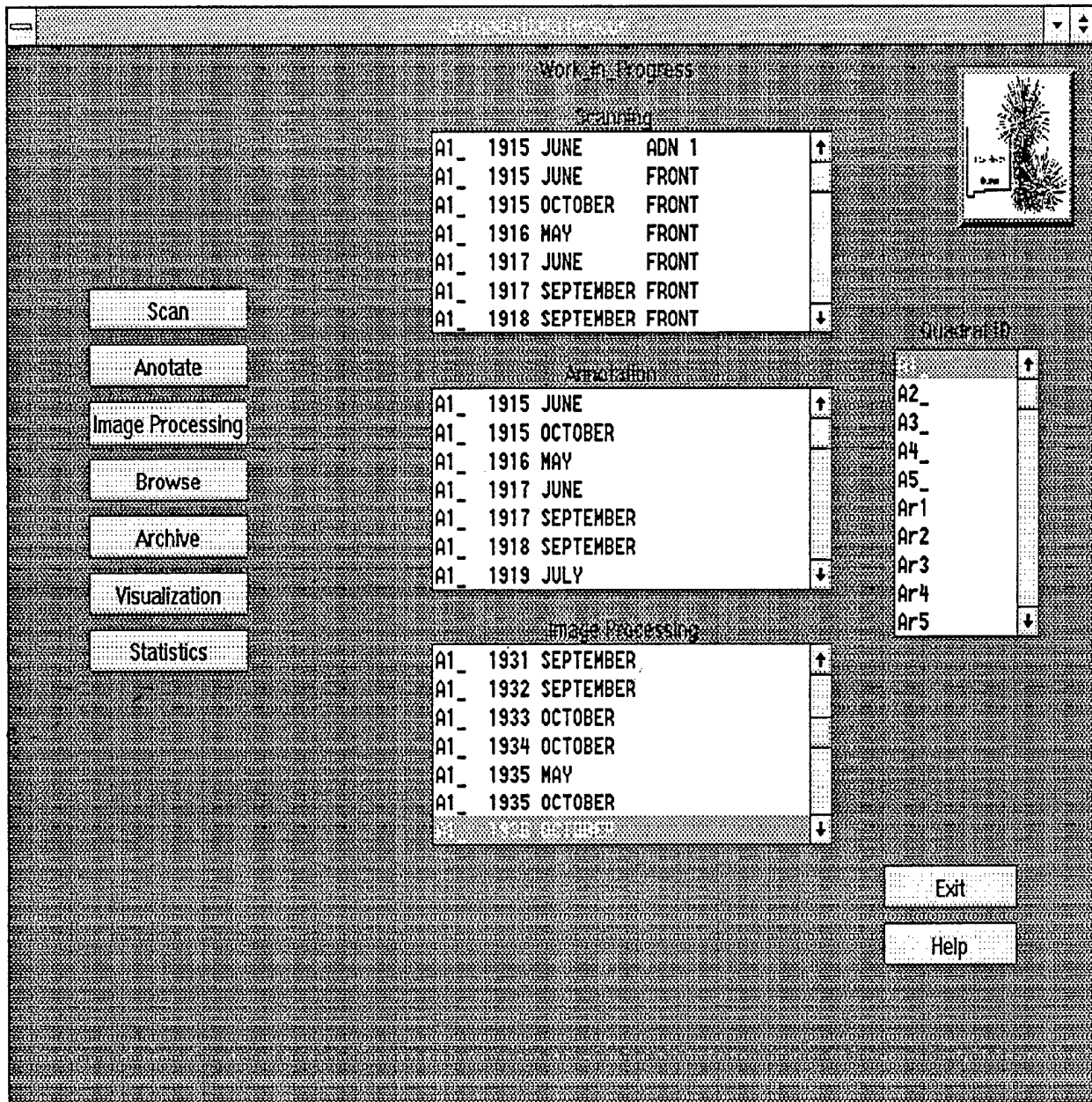

Figure 1. JDR System Main GUI

#### **4.1.2 Procedures**

The data capture procedure consists of the following phases:

- Data Scanning
- Quadrat Annotation
- Indexing
- Contour Vectorization
- Data Archiving
- Data Browsing
- Quadrat Visualization
- Data Set Verification
- Statistical Analysis
- GIS Import
- Image Processing

##### **4.1.2.1 Data Scanning**

The initial phase in the data capture methodology is to scan the images into a digital format for archival on the workstation. The user selects the quadrat ID, year, and month of occurrence from scrollable list boxes on the GUI. Graphical buttons on the screen allows the user to indicate whether the quadrat to be scanned is a front scan (the actual pantographed quadrat), a back scan, or one of the addendum sheets (field notes pertaining to the map). Error checking is done to insure that the data has been entered correctly before allowing the user to scan the image. The Scan GUI is shown in Figure 2.

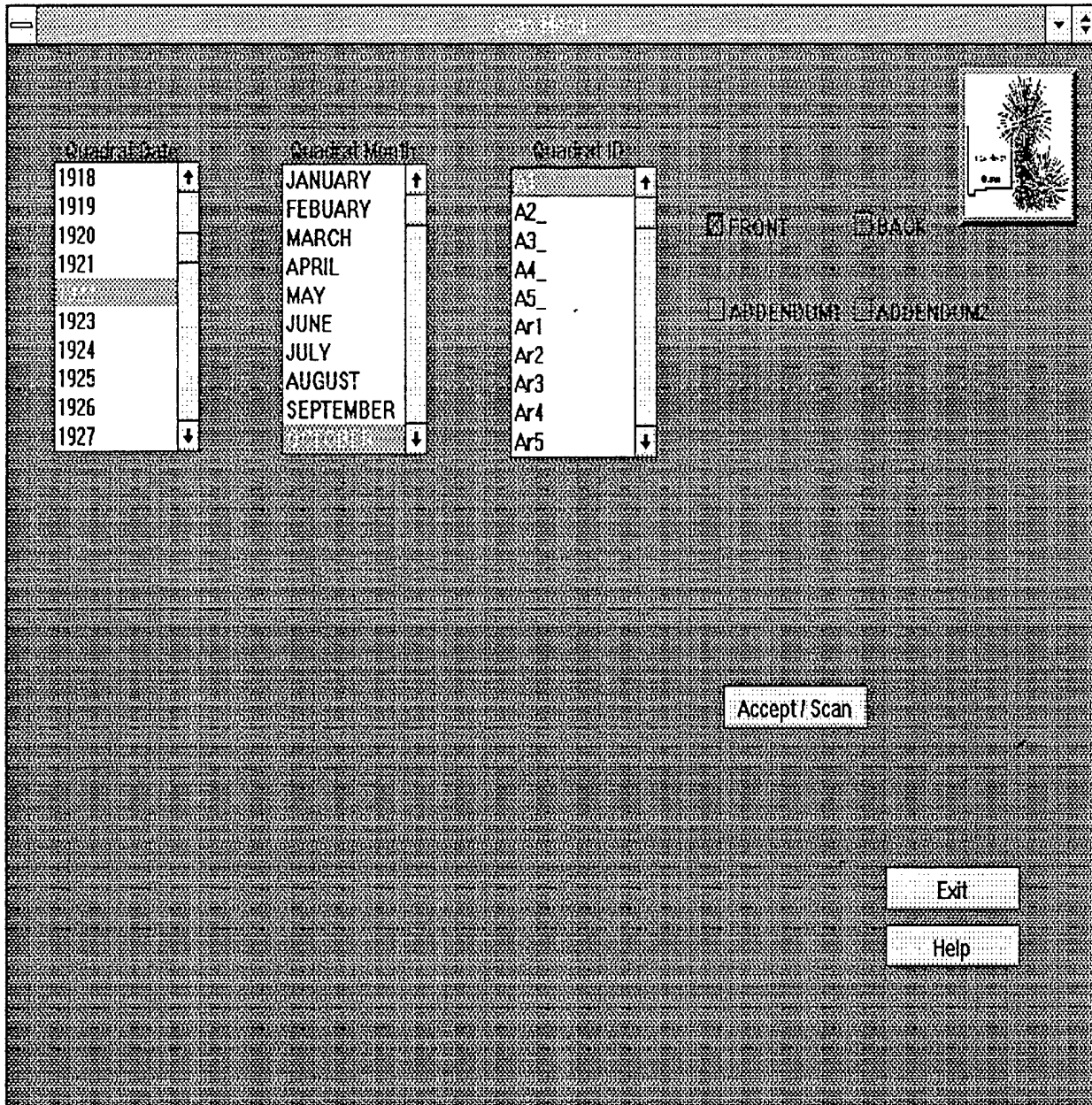

Figure 2. Scan GUI

The user then places the image on the scanner and presses the graphical scan button. Scanning is performed at 100 DPI, using 256 colors. The scanned image is then displayed on the workstation. The user visually verifies that the image is aligned and that it matches the description entered in the computer.

During the scanning process, the system informs the user when the system hard disk drive is nearing full capacity. When this happens, the GUI allows the user to archive the data. The archival procedure converts the images into compressed GIF format and stores them in an archive directory. This directory is then backed up to a 4mm Digital Analog Tape (DAT) until a complete set of data has been scanned.

#### **4.1.2.2 *Quadrat Annotation***

The second phase in the data capture procedure is quadrat annotation. Each plant contour is labeled with a code, consisting of 1-6 letters, and is then indexed in an annotation list on the bottom of the quadrat sheet. The annotations are a mixture of common plant names, old and new scientific (Latin) names, and abbreviations.

The GUI provides 750 common, old/new Latin, and abbreviated names used in describing plants (located within the quadrats) that the user might encounter. These names are cross-referenced to over 200 current Latin names. There are approximately 1000 codes used.

During the data scanning phase, an empty annotation file is created for each front-scanned image that contains the encoded name of the quadrat. During annotation, the user selects the working quadrat from a list box and enters into the annotation GUI. This GUI displays the master botanical list and the quadrat annotation list in scrolling list boxes. The Annotation GUI is shown in Figure 3. Using the mouse, the user selects a plant entry from the master botanical list and copies it into the quadrat annotation list. If multiple codes were used throughout the years to index the selection, the user is prompted with the possible codes and requested to select the one used on the working quadrat. If only one code was used, selection is done automatically. When the copy takes place, the code and the current Latin name of the plant species is updated in the annotation list. The user follows this procedure until all entries in the annotation list are complete. An example of a quadrat annotation list is provided in Appendix A.

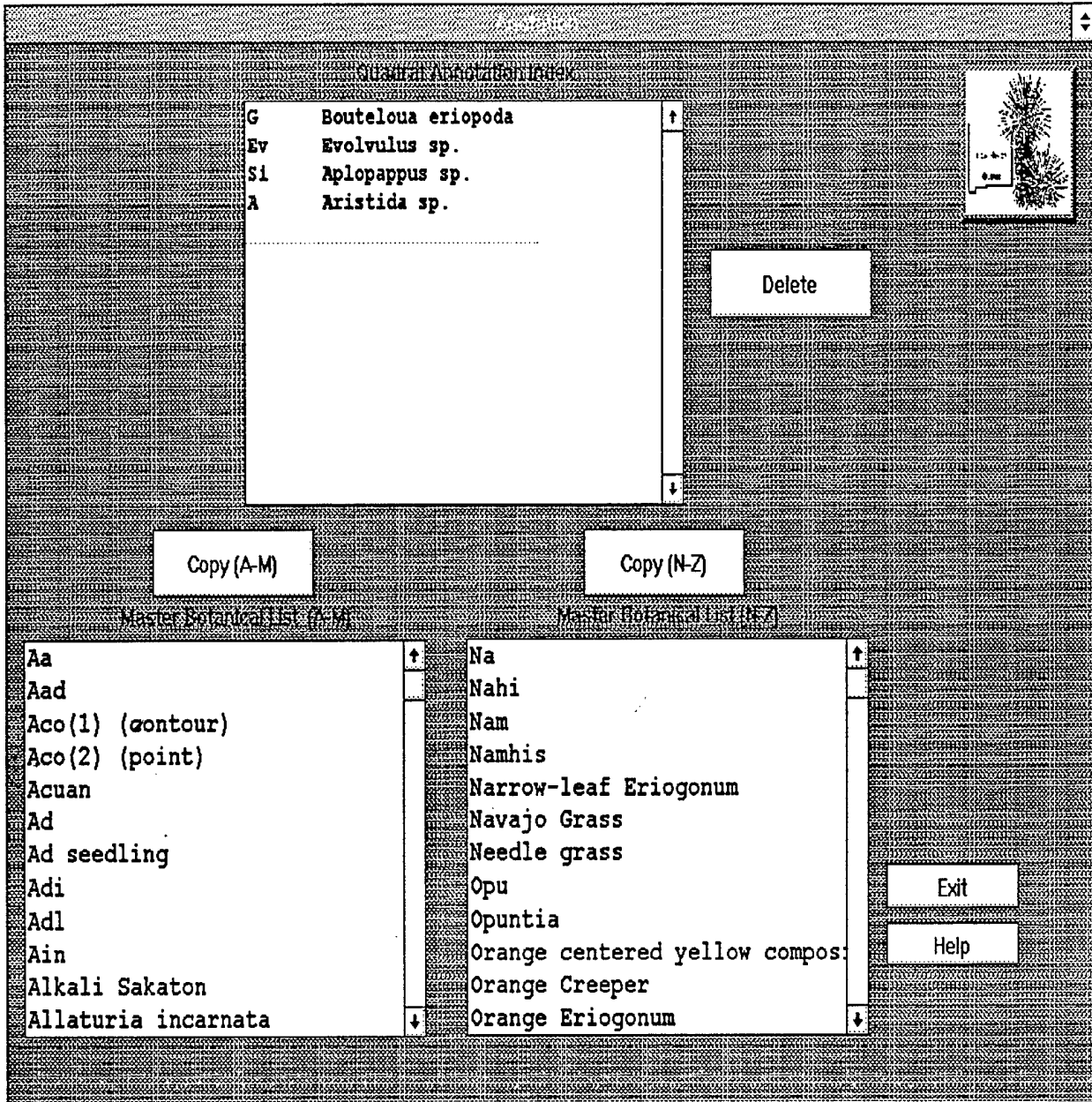

Figure 3. Annotation GUI

Since the annotation data capture was performed by students without any specialized botanical background, it was necessary to collate and cross-reference all of the annotation naming conventions used on the quadrats. The quadrats were reviewed, and the names and codes were entered into a file (NOTE: the codes did not remain consistent per plant species throughout the years). USDA/ARS JER botanists then referenced these names/codes to current scientific Latin names. Certain plant information was unrecoverable due to the annotation entries, e.g., "unknown weed". The sources used for identifying plant names are listed in Appendix B.

#### 4.1.2.3 Indexing

The next phase in the data capture procedure is indexing. Several indexing files were created to permit the user to capture the data sets without requiring expert knowledge of the local flora. These include the master botanical list, Latin list, and images list.

The master botanical list (Appendix C) contains several entries: the common name which appears on the GUI under the master botanical list, the current Latin name, the current Latin name index, and the possible plant code indices.

Several plants on the list have "!grass", "!forb", etc. as their Latin names. These names are used when the annotation on the quadrat sheet makes it impossible to determine the actual Latin name. For example, under the common name "six-weeks grass", there are three entries to reflect three different codes used by the field workers. When the code "Bba" was used for the six-weeks grass name, the plant was identified as "Bouteloua barbata". When the code "Aad" was used for the six-weeks grass name, the plant was identified as "Aristida adcensionis". But, if the code "Sx" was used, it was impossible to determine whether the plant was the annual (barbata) or the perennial (adcensionis) six-weeks grass; therefore, the plant was identified only as "!grass".

The Latin list (Appendix D) contains the current Latin name index, the plant variety classification, the plant visualization index, and the current Latin name. The Latin name index is used to point into the Latin list from the annotation and master botanical lists. The plant visualization index is used to point to the images list (Appendix E), which contains Lindenmayer system-generated representations of certain plant species (1990). These visuals are used to build the quadrat visualizations described later. The images list contains indicator plant species and generalized plants. The generalized plants are included to provide visualizations of the quadrat when the actual variety of the plant specimen is not critical. In some instances, it is not critical to picture the actual species of, for example, a forb, but rather to convey the fact that a forb was located on the quadrat. Under the visualization GUI, the actual specimen name is provided, but its graphical representation is the generalized plant. Other indicator plant species have actual visual representations due to their importance

or abundance. The Latin list also contains the classification index, which is used in statistical processing to group perennial grasses, annual grasses, forbs, and shrubs.

#### **4.1.2.4 Contour Vectorization**

The next phase in the data capture procedure is to convert the scanned images from the raster format (image pixels) to vectors which describe the plant outline, its location within the quadrat, and the plant species.

In order to vectorize the quadrat, the user selects the quadrat from a list box and enters the Image Processing GUI (Figure 4). The scanned quadrat image is then displayed. The operator uses the mouse to select the four corners of the quadrat area. This is required because the quadrat area on the graph paper varies between years. Once the corners are selected, the GUI displays the annotation codes, along with the defined quadrat area of the image. Using the mouse, the user selects a code, and then digitizes the related contour. The heads-up digitization process is performed by placing the mouse pointer on the desired contour, clicking the mouse button, moving to the next point on the contour, and clicking the mouse button until the outline is complete. The digitized vector is highlighted in a bright blue color and the starting point is encapsulated with a circle marker. The vector for a contour is a series of linear X and Y coordinate offsets from the geopositioned corner of the quadrat. This information is saved, and the user continues on to the next contour. The ability to remove sections of the contours or entire contours is built into the GUI. Once the quadrat is completed, the user is given an opportunity to review the overlaid vectors versus the scanned quadrat area and decide if the vectorization is complete and accurate or whether additional work is required.

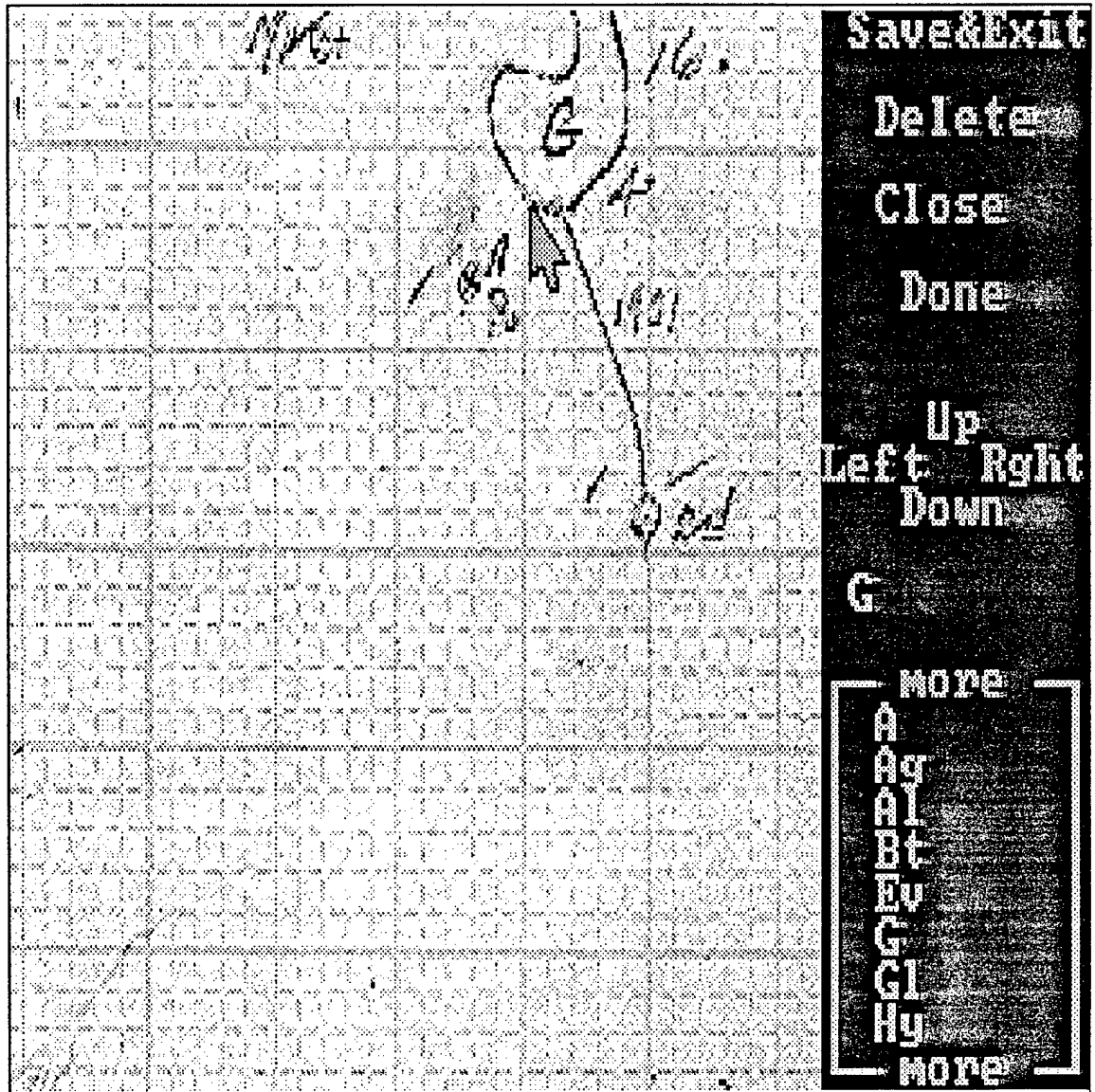

Figure 4. Image Processing GUI

#### **4.1.2.5 Data Archive**

Archiving the annotation and contour vector files is done in the same manner as described in section 4.1.2.1 for the scanned images. The files are saved to an archive directory on the system hard drive, and then to tape, with a final archiving process to CDROM. The annotation and contour vectors require considerably less disk space than do the scanned images, so they may be left on the hard drive for quicker access. These files are related by the system to one another via the encoded file names. This enables the user to access all files related to a quadrat. The Archive Quadrat Data GUI is shown in Figure 5.

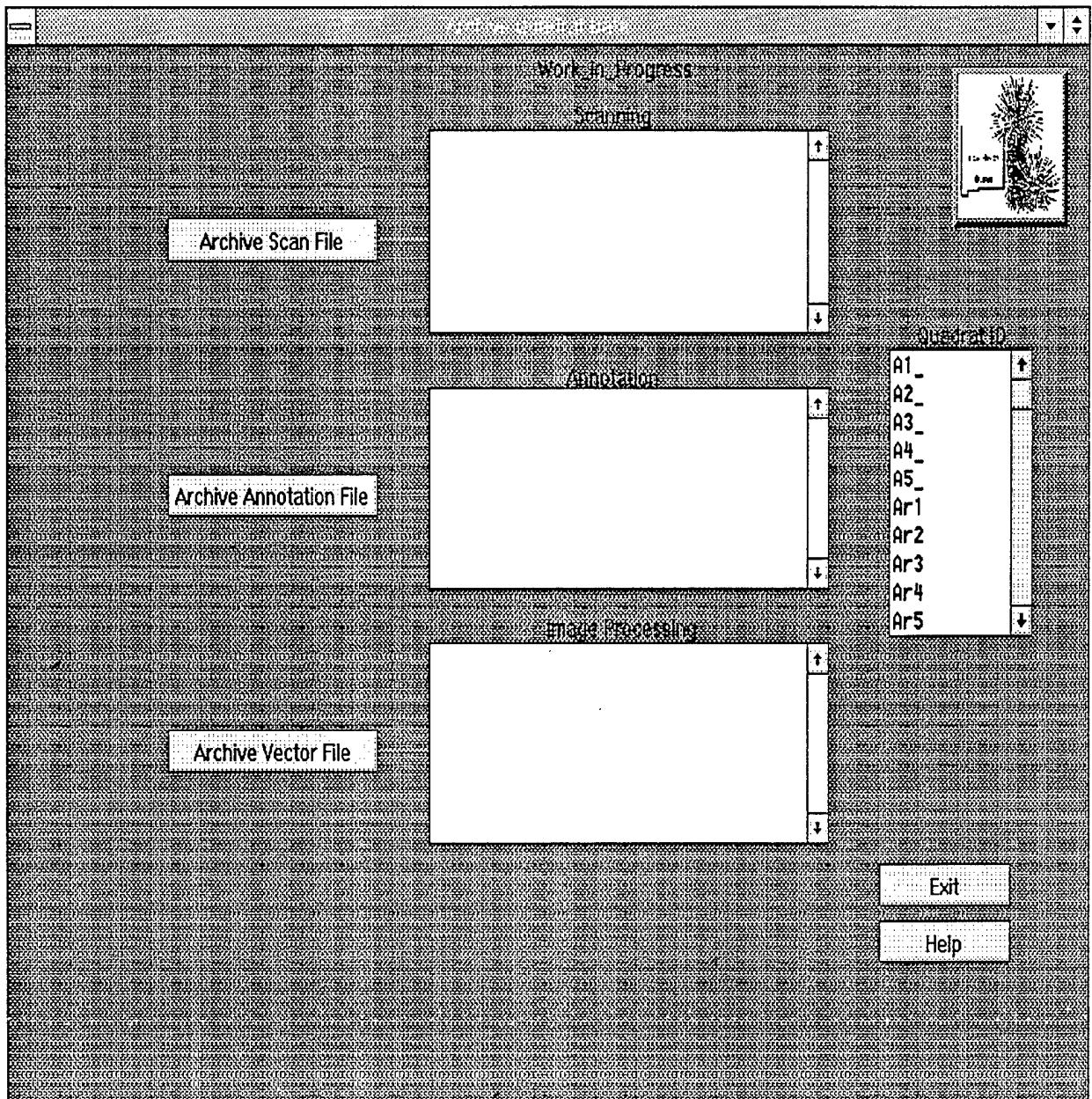

Figure 5. Archive Quadrat Data GUI

#### **4.1.2.6 Data Browser**

The data browser GUI allows the user to examine the archived data that has been stored in the archive directories or on the CDROM drive. This GUI permits the user to view the images in a normal or zoomed scale, view the associated annotation list, retrieve individual quadrat data, or retrieve all data related to a particular quadrat. List boxes on this GUI indicate the data that is available to the user for viewing or retrieval. Data is retrieved using this GUI in preparation for analysis, export, or visualization. The Archive Browser GUI is shown in Figure 6.

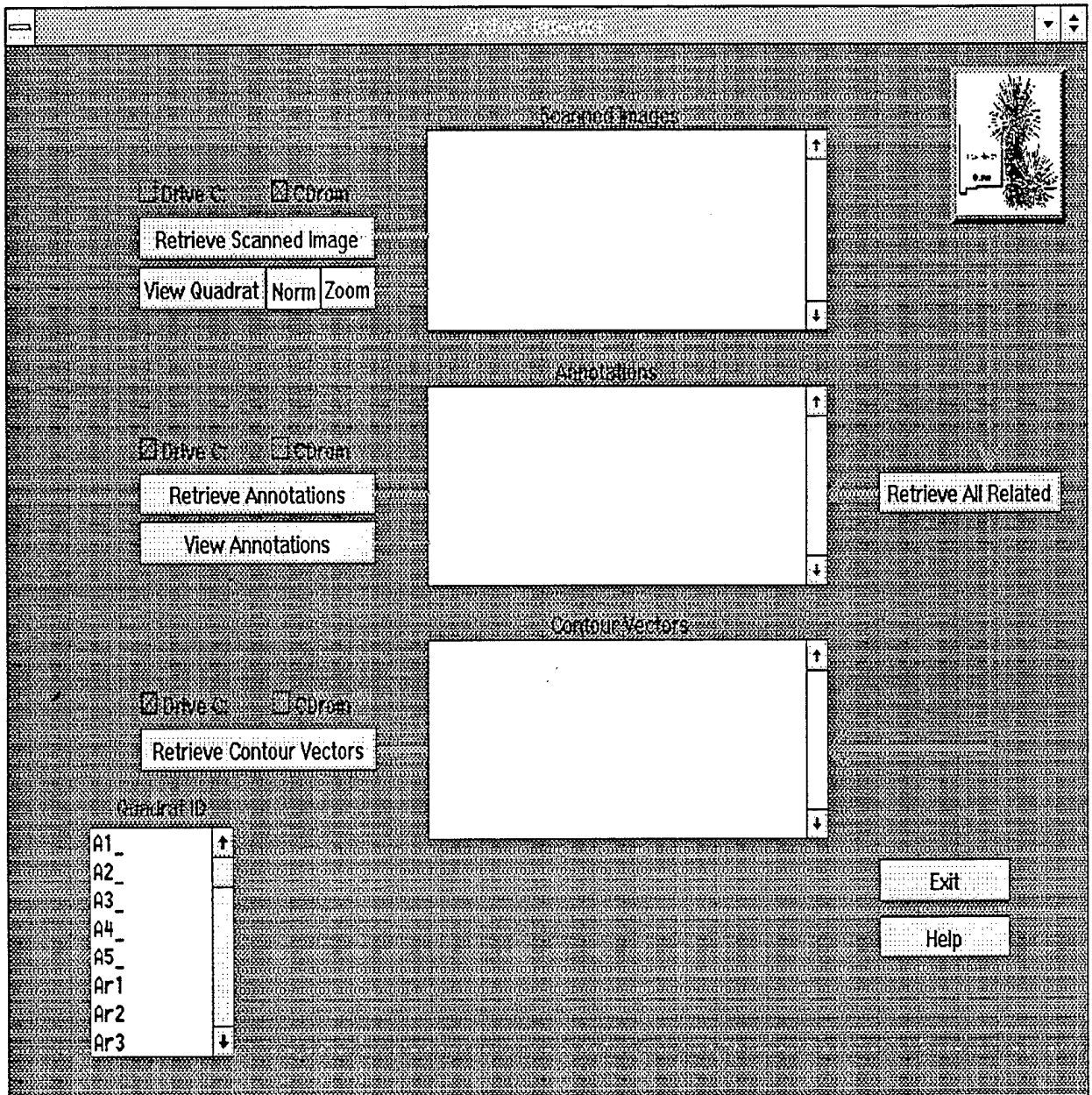

Figure 6. Archive Browser GUI

#### **4.1.2.7 *Quadrat Visualization***

Quadrat visualization is the process of re-populating a historical quadrat location with the representative plant community. This allows the user to see what the quadrat looked like when it was originally mapped.

During the annotation phase, the plant species indigenous to the quadrat were indexed to the Lindenmayer-generated plant graphics system. The Lindenmayer system used to generate the plant is a fractal 3-D generation routine that "grows" the plant. This routine is based on a fairly simple set of deterministic algorithms which control the growth function. Using this type of system rather than clip art representation allows the system to generate plants based on the actual plant morphology.

During the contour vectorization phase, the plant outlines were located relating to the quadrat geopositioned corner. Using this information, it is possible to reconstruct a graphical representation of the quadrat.

The visualization of the quadrat places the graphical representation of the plants on the flat surface of the quadrat. The plants are scaled to the size indicated by their contour outline vectors. Many of the plants (especially the forbs) are represented by generalized plant-forms as described above. Other indicator plants have graphical representations which depict the actual plant species.

Appendix F contains a representative sample of geopositioned augmented and annotated quadrat data.

#### **4.1.2.8 *Data Set Verification***

One of the primary benefits of being able to visualize the quadrats with plant forms in place is the location of questionable plant placement and identification. The JDR System utilizes two methods to perform data verification. The first method uses the quadrat visualization procedure described in section 4.1.2.7. The user can examine the quadrat and query the plant species at any location on the quadrat. This provides a standalone capability for the JDR System to both visualize and verify the data.

The second method of verification uses a more powerful platform for visualization. This method requires the PC-based JDR System to be networked to the environmental workstation (Silicon Graphics Crimson class computer), and allows the user to transmit certain portions of the data set to the workstation. On the workstation, the data is visualized using a modified public domain ray-tracer such that the quadrats may be rapidly viewed in temporal order. The user may step forward or backward through the years to view the plot. The ability to query individual plants is a feature of this system.

Rapidly stepping through the quadrat series enhances the ability to detect and correct different types of errors. For example, if a perennial grass species identified on a quadrat location for several consecutive years changes to a different species in a successive year, then changes back to the original species, it may be assumed that the plant was mis-identified in the year that the plant form changed. The data set can then be corrected by updating the quadrat annotation list and the processed image. If the location of perennials or shrubs on a quadrat indicates that the quadrat has been rotated, a set of auxiliary functions can be run on the JDR System. These functions rotate the contour vector data by either 90 degrees (left or right) or 180 degrees. Once this is done, the contour overlays will not match the scanned image, but the useful data (contour vectors) are correctly oriented. Once the corrections are made to the data set on the JDR System, the quadrat visualization may be re-generated and viewed as verified historical data. The Quadrat Visualization GUI is shown in Figure 7.

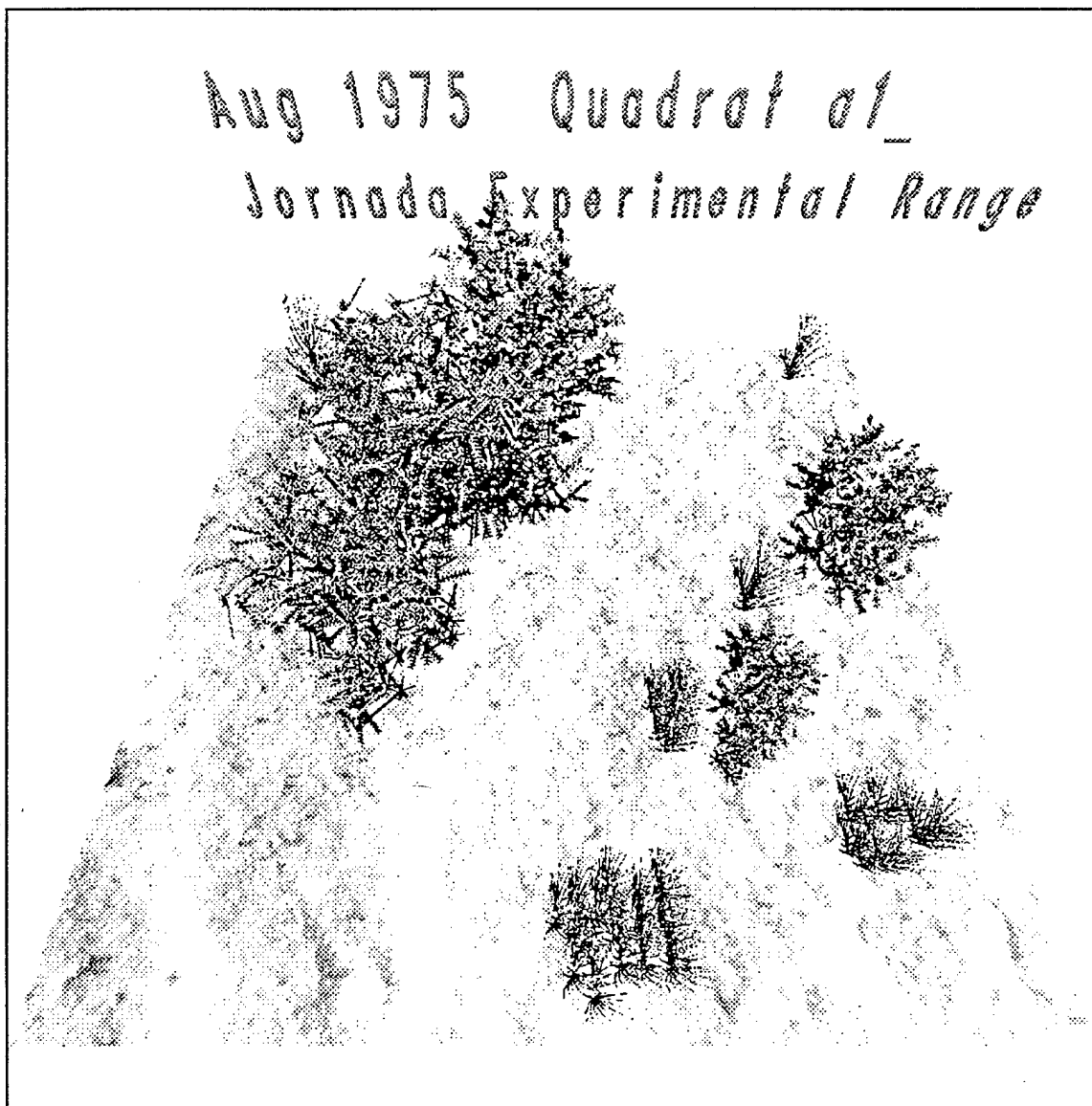

Figure 7. Quadrat Visualization GUI

#### 4.1.2.9 Statistical Analysis

The statistical analysis of the acquired data set is an extremely important aspect of the capture and ultimate use of the legacy data. By abstracting the data, through the correlation of temporal changes in the biotic composition of the quadrat sets, USDA scientists can analyze the causal effects of desertification of arid landscapes. The JDR System provides a simple mechanism to perform the analysis and examine the results.

After the data sets are scanned, annotated, image-processed, and verified, the user can enter the Statistical GUI (Figure 8) to collate and compare the acquired data. The Statistical GUI allows the user to perform correlations on either plant basal area coverage or plant occurrence. The correlations may be performed on plant classification groups, e.g., perennial grasses, annual grasses, shrubs, forbs, and/or individual species. The user selects the classifications/species of interest, coverage or occurrence, the years/months of interest, a set of quadrats, and the output plot display preference (2D or 3D). Once these are selected, the "statistics" button is pressed and the information is passed to the Quattro Pro® statistics package resident on the JDR System. A macro is created for Quattro Pro® that collates and displays the requested data as a comparison plot. The user has the option, after viewing the plot, to print it or to return to the Statistical GUI. Many data correlations may be produced using this package in a very short time. Examples of the statistical plots are included in Appendix G<sup>1</sup>.

---

<sup>1</sup>These statistical plots summarize the temporal dynamics of forage grasses. The Y-axis value, "Count", represents the number of plant species on the quadrat.

ISEM Final Report, Volume 1

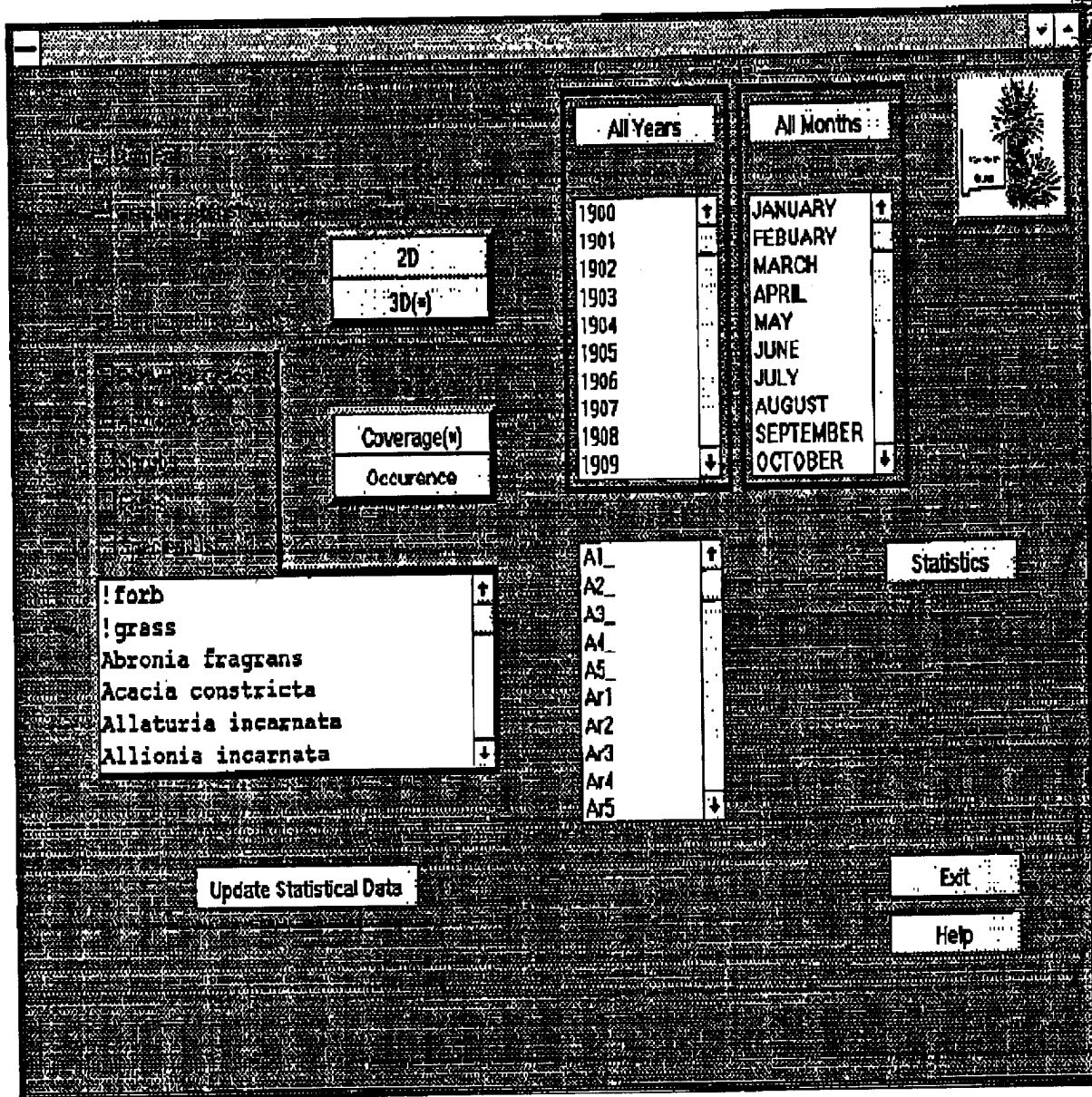

Figure 8. Statistical GUI

It is anticipated that additional correlation parameters such as grazing intensity and rainfall data will be included in the GUI. Inclusion of these data sets will permit the user to perform cause and effect analysis.

#### 4.1.2.10 GIS Import Methods

##### 4.1.2.10.1 Quadrat Import

Coordinate data for quadrats A1-A5, AR4-AR6, and B1-B5 were provided to TEC by NMSU in ARC/INFO® Generate format. ARC/INFO® Generate files have a simple structure of a feature identifier, a list of coordinate pairs representing plant basal areas, and an end-of-file delimiter. The quadrat coordinate data are in units of millimeters, with the origin in the upper left corner of the quadrat. Data exists for the 1915 to 1977 time period, inclusively. The latitude and longitude of the quadrats was provided on a separate list. Also provided was a Latin list file containing the current Latin name index, plant codes, and the current Latin names.

TEC's primary goal in processing the quadrat data was to create ARC/INFO® point, line, and polygon coverages for each year in the period of record. The processing to create the ARC/INFO® coverages involved the following steps:

- creating multiple workspaces for each year in the period of record using program mul\_cw.aml (hardcopies of all programs referred to in this document are provided in Appendix H).
- recalculating the Y values in the Generate format files using program recal\_y. This step was required in order to translate the coordinate origin from the upper left (as received from NMSU) to the lower left (as required by ARC/INFO®).
- separating point, line, and polygon features in the original Generate files with results still in Generate format using program sepquad. This step is required by the ARC/INFO® data structure, which in most cases places each feature type into separate coverages.
- using a text editor to create an ARC/INFO® projection file specifying the following output parameters: Universal Transverse Mercator (UTM) projection (zone 13), units of meters, and geodetic datum of North American Datum of 1927.

- creating ARC/INFO® point, line, and polygon coverages using program `mul_gener.aml`. This program performs the following functions: checks that workspaces previously created are valid; places data on a cartographic projection; transforms the coverage from user-defined units to real world units; establishes topological relationships; and adds an item for plant codes.
- creating a plant code look-up table containing plant codes and Latin names using the program `define.aml`.
- creating a relate file using the program `addrelate.aml`, which links the spatial data and attribute data using the plant codes as the key.

#### **4.1.2.10.2 Precipitation Data Import**

Precipitation data was provided to TEC by NMSU in Lotus® spreadsheet format (\*.wk1). Every rain gauge at which precipitation data is collected is contained in a separate file with years as rows and months as columns. Yearly total, rainy season (July, August, and September) total, and number of months with data counts are also included. The precipitation data are in units of inches. Data exists for the 1915 to 1993 time period, inclusively. The latitude and longitude of each rain gauge was provided on a separate list.

TEC's goals in processing the precipitation data were:

- creation of ARC/INFO® point coverages for each year in the period of record;
- application of interpolation algorithms to the point data to create precipitation surface maps;
- generation of time series and 3-year moving averages of the precipitation data sets.

The processing to create ARC/INFO® point coverages involved the following steps:

- transferring the monthly precipitation data to EXCEL® software for quality control purposes. Due to short, discontinuous periods of record, gauges 29, 31, 32 and 33 were omitted from the analysis. Where a gauge's monthly value was missing, an estimated value was inserted based on the nature of the gauge's precipitation characteristics and the relationship to adjacent gauges.
- converting the spreadsheet files from Lotus® format into ASCII format.

- extracting yearly total and rainy season total with commas inserted as delimiters using program precip\_redist. Note that individual monthly precipitation values were not brought into ARC/INFO®.
- using the INFO command DEFINE to create data files in the applicable INFO directories containing fields for yearly total and rainy season total.
- adding records pertaining to the above fields using program add\_precip.aml.
- creating an ARC/INFO® point coverage of rain gauge locations by interactive entering of rain gauge latitudes and longitudes.
- repeatedly using the ARC command JOINITEM with the LINK option to create an INFO file with rain gauges as rows and rain gauge latitudes, longitudes, yearly total, and rainy season total for each year as columns.

Interpolation of the point precipitation data was performed using two separate software packages. The first processing flow involved the import of the original precipitation spreadsheet data into Surfer®, a PC-based statistical package. The second processing flow involved interpolation within ARC/INFO® to change point data into an isohyet map showing lines of equal precipitation.

For each of the gauges used in the analysis, the UTM coordinates and the applicable precipitation values were imported into Surfer® (Version 4.15) in Lotus® 1-2-3 format and is defined as the Surfer®-based interpolation. Using the GRID module of Surfer®, a surface contour plot was generated. Surfer® offers 3 grid interpolation methods--inverse distance, kriging<sup>2</sup>, and minimum curvature. Since this version of Surfer® assumes a linear variogram, products were generated using the inverse distance method.

The ARC/INFO®-based interpolation was performed only on the 1993 yearly total of precipitation at all rain gauge locations. This procedure was performed as a proof-of-principle and for qualitative comparisons with the Surfer®-based interpolation. The first step in this protocol was to create a Triangulated Irregular Network (TIN) from the rain gauge point coverage using the ARC command CREATETIN. TINs are commonly used in GIS applications to represent continuous surfaces based on irregularly-spaced sample points and breakline features. The ARC command TINCONTOUR was then run on the TIN to create the isohyet map.

---

<sup>2</sup>Kriging is discussed further in Section 4.4.1.

With respect to the third goal, a time series graph was generated using the graphing function found in EXCEL® 4.0. The 3-year moving average of precipitation and the July-September Cumulative Precipitation graphs were created using EXECUSTAT® software.

#### 4.1.2.10.3 Grazing Data Import

Attribute data on historical grazing intensities was provided to TEC by NMSU in Lotus® spreadsheet format (\*.wk1). On the spreadsheets, every year of grazing data is contained in a separate file with pastures as rows and months as columns. A yearly total column is also included. The grazing intensity data are in units of Animal Unit Months. The period of record covered by the data was 1953 to 1993, inclusively.

With respect to spatial data, an ARC/INFO® coverage was provided to TEC by NMSU which represents the locations of pasture fencelines on the JER. This coverage, after minor editing, is valid for 1993 only.

TEC's goal in processing the grazing data was to create ARC/INFO® coverages for each year in which there was both grazing data and pasture fence line data. The processing involved three major steps:

- editorial preprocessing
- import of attribute data into INFO
- linking of spatial and attribute data

Steps performed in the editorial preprocessing stage were:

- stripping the spreadsheet files of headers and footers unnecessary to ARC/INFO® using program output\_txt2.
- checking for and removing spurious columns using program pre\_redist.
- inserting commas (required by ARC/INFO®) as output field separators using program output\_txt3.

Steps performed in the INFO import stage were:

- using the INFO command DEFINE to create data files in the applicable INFO directories containing fields for pasture name, animal type, monthly animal unit months, and yearly animal unit months.

- using the INFO command ADD to add records pertaining to the above fields.
- using the ARC command ADDITEM to add a column (TOTAL2) representing the yearly sum for all animal types. Note that on the original spreadsheets, the yearly totals given are for specific types of animals (e.g., cattle) or groups of animals (e.g., sheep and goats), but not for the sum of all animal types.
- calculating TOTAL2 using ARC Macro Language (AML) program pastures.aml.

Only one step was required to link the spatial and attribute data:

- create a relate file using the ARC command RELATE, which links the spatial and attribute data using the pasture names as the key.

#### ***4.1.2.10.4 Digital Elevation Model Data***

The Level I Digital Elevation Model (DEM) data available at NMSU for the JER has a "banding" problem and is not usable for modeling. Level II DEMs do not have this problem and are currently being produced by the United States Geological Survey (USGS) for the JER area. In an effort to create acceptable DEMs from the Level I DEM for the study site, TEC developed a procedure to transform an existing set of ARC/INFO® contour coverages into both USGS and ARC/INFO® formatted DEMs. The contour coverages were created by NMSU by digitizing contour lines on 1:24,000 topographic quadrangles and were provided to TEC in ARC/INFO® Generate format. TEC's processing of these coverages involved three steps:

- execution of a program called hypsodem.eas, written in the EASI macro language of the PCI image processing package.
- unblocking of the DEMs written by hypsodem.eas using the program cnvrtdem.
- import of the unblocked DEMs into ARC/INFO® using the command DEMLATTICE.

#### ***4.1.2.11 Image Processing***

Four primary image data sets were used for this project: SPOT multispectral, SPOT panchromatic, Landsat Thematic Mapper (TM), and Landsat Multispectral Scanner (MSS). The data sets were used in the following fashion:

*ISEM Final Report, Volume I*

- SPOT multispectral--land use/land cover mapping, spectral vegetation indices
- SPOT panchromatic--image data merging
- Landsat TM--image data merging
- Landsat MSS--change detection

The SPOT data sets were preprocessed by the data vendor to account for earth curvature effects, earth rotation, variations in detector bias and gain, and panoramic effects. Also, the data vendor performed geocoding of the data set using a map-to-image registration technique in which image identifiable control points were selected off of standard USGS topographic maps. The control points were then related to the corresponding pixels in the image to develop polynomial transformation equations. These equations were used to transform all pixels in the image. The results were images placed on the UTM projection based on the North American Datum of 1927 (NAD 27) with frame sizes corresponding to USGS 15 minute topographic maps. The data vendor claims that accuracies compliant with U.S. National Map Accuracy standards were achieved, but was unable to provide specific error estimates for these data sets.

The TM data set was provided to TEC by NMSU already geocoded to a UTM projection and NAD 27. The scene was clipped to an irregularly-shaped boundary matching the broader Jornada basin study area. The types of radiometric pre-processing performed on this data set are unknown.

The Landsat MSS data sets were preprocessed by the EROS Data Center to account for band-to-band offsets, line length disparities, earth rotation, and variations in detector bias and gain. EROS also performed a geocoding step in which the data sets were placed on the Space Oblique Mercator projection with a footprint of 185 km x 185 km.

No atmospheric corrections were attempted on the SPOT or Landsat TM image data sets.

The first image data set is a multispectral SPOT View scene from June, 1993. The multispectral SPOT data has the following characteristics:

Number of rows:	1404
Number of columns:	1197
Ground sampling dimension:	20 meters
Band passes:	3 bands (um): 0.5 - 0.59, 0.61 - 0.68, 0.79 - 0.89

The second image data set is a panchromatic SPOT View scene from June, 1993. The multispectral SPOT data has the following characteristics:

Number of rows:	2809
Number of columns:	2392
Ground sampling dimension:	10 meters
Band passes:	1 band (um): 0.51 - 0.73

The third image data set is a multispectral Landsat TM scene from August, 1992. The multispectral TM data has the following characteristics:

Ground sampling dimension:	30 meters (bands 1-5, 7) / 120 m (band 6)
Band passes:	7 bands (um): 0.45 - 0.52, 0.52 - 0.60, 0.63 - 0.69, 0.76 - 0.90, 1.55 - 1.75, 2.08 - 2.35, 10.4 - 11.7

The final image data sets are Landsat MSS scenes from July, 1983 and August, 1992. The MSS data has the following characteristics:

Number of rows:	2983
Number of columns:	3596
Ground sampling dimension:	80 meters
Band passes:	4 bands (um): 0.5 - 0.6, 0.6 - 0.7, 0.7 - 0.8, 0.8 - 1.1

#### 4.1.2.11.1 Land Use/Land Cover Maps

The generation of land use/land cover maps from satellite multispectral imagery has traditionally been performed using the two basic techniques of supervised and unsupervised classification. The overall objective of both techniques is to categorize or label all pixels in the image into land cover classes or themes. One of the challenges of this project was to identify a land cover classification scheme that meets the objectives of resource management and is extractable from satellite imagery. The land cover classification scheme selected, from Hutchinson and Warren (1983)<sup>3</sup>, is life form-based and has five classes:

- 1) Perennial grassland (black grama/mesa dropseed) - grassland with low shrub cover and high perennial grass diversity.
- 2) Perennial grassland (mesa dropseed/snakeweed) - grassland with snakeweed and moderate grass cover, but few mesquite.

---

<sup>3</sup>See Appendix B for full bibliographical references.

- 3) Half shrubland (snakeweed/mesa dropseed) - stands of snakeweed with low grass cover and few mesquite.
- 4) Shrubland (mesquite/snakeweed) - shrub association dominated by mesquite and snakeweed with low grass cover and no coppice dune formation.
- 5) Shrubland (mesquite/snakeweed) - shrub association dominated by mesquite and snakeweed with very low grass cover and distinct coppice dune formation.

### *Unsupervised Classification*

Unsupervised classification involved the following steps:

- identification of key parameters for the clustering algorithm: number of classes = 5; source of initial cluster means = arbitrary; number of iterations = 20; convergence threshold = 95%.
- classification or categorization of each pixel into land cover classes based on statistical algorithms that relate pixels based on their similarities and differences in multispectral space. An Iterative Self-Organizing Data Analysis Technique (ISODATA), which forms clusters by iteratively using a minimum spectral distance formula, was used on this project.
- labeling of clusters based on ground-truth data.
- post-classification smoothing to remove the salt-and-pepper appearance. The technique used in this project was to pass a 3 X 3 pixel filter over the image in which the center pixel is changed, if necessary, to the majority class within the filter.
- assessment of the accuracy of the classification.

### *Supervised Classification*

Supervised classification involved the following steps:

- user identification of representative training areas, which are sample sites of known cover type. The ground-truth data used to identify known cover types was provided to TEC in spreadsheet format.
- generation of spectral signatures, which are numerical descriptions of the spectral response patterns of each land cover type of interest in the image.

- classification or categorization of each pixel into land cover classes based on statistical algorithms that relate pixels based on their similarities and differences in multispectral space. A maximum likelihood algorithm was used on this project.
- post-classification smoothing to remove the salt-and-pepper appearance. The technique used in this project was to pass a 3 X 3 pixel filter over the image in which the center pixel is changed, if necessary, to the majority class within the filter.

A total of 49 sample points matching the selected classification scheme were provided with 15 samples in category #1, 12 samples in category #2, 3 samples in category #3, 4 samples in category #4, and 15 samples in category #5. The sample points were divided up for use as training sites and test sites.

#### **4.1.2.11.2 Spectral Vegetation Indices**

Spectral vegetation indices are formed by arithmetically combining various vegetation-sensitive spectral bands. These indices have correlated directly with important vegetation parameters, including proportions of absorbed photosynthetically active radiation, photosynthesis, stomatal conductance, vegetation life form, primary production, and surface albedo (Asrar et al., 1984; Sellers, 1985; Myneni et al., 1992; Prince, 1991). While several dozen indices have been proposed in the academic literature, the two principal indices most often used are the Normalized Difference Vegetation Index (NDVI) and the Soil-Adjusted Vegetation Index (SAVI). The SAVI was developed specifically to address a major problem in arid lands remote sensing of vegetation, which is the high degree of soil and mineral background influence in spectral reflectances due to low canopy cover (Huete, 1988). The SAVI is computed as  $[(\text{NIR} - \text{RED})/(\text{NIR} + \text{RED} + L)](1 + L)$ , where NIR is near infrared, RED is visible red, and L is a coefficient adjusting the reflectance values for soil brightness. The SAVI was chosen for this project with the L term set equal to 0.5.

A SAVI image was created as follows:

- generate output channels with appropriate row/column dimensions, pixel dimensions, and radiometric resolution.
- subtract SPOT band 2 from SPOT band 3.
- add SPOT bands 2 and 3.
- divide the two results and multiply by 1.5.

#### **4.1.2.11.3 Change Detection**

An important aspect of environmental management is the development of rapid, inexpensive techniques to perform large area change detection. A suitable remote sensing data source for regional scale change detection is Landsat MSS data for which time series data from the early 1970s to the present is available. Two MSS images from 1983 and 1992 were acquired for this project and used to prototype two automated change detection protocols.

The change detection protocol used involved the following steps:

- precise image-to-image registration using a second degree polynomial and 15 ground control points.
- assessment of the registration accuracy using 12 registration checkpoints.
- correction for atmospheric scattering using a regression-based radiometric correction.
- application of two separate change detection algorithms (Euclidean distance and standardized principal components).
- correlation analysis of the results of the two change detection algorithms.

#### **4.1.2.11.4 Image Data Merging**

The trade-off between spatial and spectral resolution is a classic one in remote sensing science. SPOT panchromatic image data is strong spatially (ground sample distance of 10 meters), but is poor spectrally (one broadband image channel in the visible wavelengths). Landsat TM data, on the other hand, is strong spectrally (seven image channels in the visible, near infra-red, and thermal infra-red), but suffers in spatial resolution (ground sample distance of 30 meters for six of the seven bands). Protocols have been developed to overcome this trade-off by merging channels from SPOT and Landsat into a composite image database.

The steps involved in image data merging used on this project are:

- assemble three geocoded TM image channels (0.45 - 0.52, 0.52 - 0.60, 0.63-0.69  $\mu\text{m}$ ).
- convert TM data from the red-green-blue color model to the intensity-hue-saturation color model.

- replace the intensity channel with the SPOT panchromatic image channel (0.51 - 0.73).
- convert merged image channels from intensity-hue-saturation space back to red-green-blue space.

## **4.2 Geographic Information System Backgrounds**

The integration of the JER data sets into a Geographic Information System (GIS) database permits the seamless access to the wide variety of information required by range managers and researchers. The GIS chosen by JER is ARC/INFO®, which is an industry standard GIS with a wide distribution and user base. The PC version of this GIS is currently being used by JER and therefore is the logical choice for this implementation.

### **4.2.1 System Description**

The GIS is incorporated on a Silicon Graphics (SGI) Crimson class workstation, which provides the speed, graphics capabilities, and storage capacity needed for this type of system. This machine forms the foundation of the Environmental Management System. The workstation is closely networked to other SGI and Sun workstations, which provide additional storage and computational power for the visualization and data backup tasks. The SGI workstation is also networked to InterNet, which provides access to external data sources as well as a mechanism for other external systems to obtain selected JER data. The PC-based JDR System described in section 4.1 is networked to the Environmental Management SGI so that data may be readily transmitted between systems. This networking provides backup capabilities for the PC-based JDR System and enables it to perform complex data visualization tasks. The Environmental Management SGI nucleus may be viewed as a tightly-coupled set of workstations and Pcs communicating through an ethernet link.

The SGI workstation has been set up with a World Wide Web (W3) server to disseminate public domain information and data as related to the JER in particular and to environmental data in general. The W3 (<http://shamu.psl.nmsu.edu/Jornada.html>) provides a standard InterNet access methodology so that most windows-based workstations and mosaic-compliant PC systems can access this data. The W3 is a hypertext-based graphical interface which has defined links to other W3 servers, as well as to data contained on the host machine. The SGI-based W3 server allows the user (across InterNet) to animate images and also to obtain data and static graphics related to the JER. The links on the W3, which point to other servers, route data sets and related information from those systems to the user. The Environmental Management Workstation (Figure 9) currently points to the TEC server and contains information on other sources of data, e.g., the Earth Data Analysis Center (EDAC) mapping services at the University of New Mexico (UNM), USGS, etc.

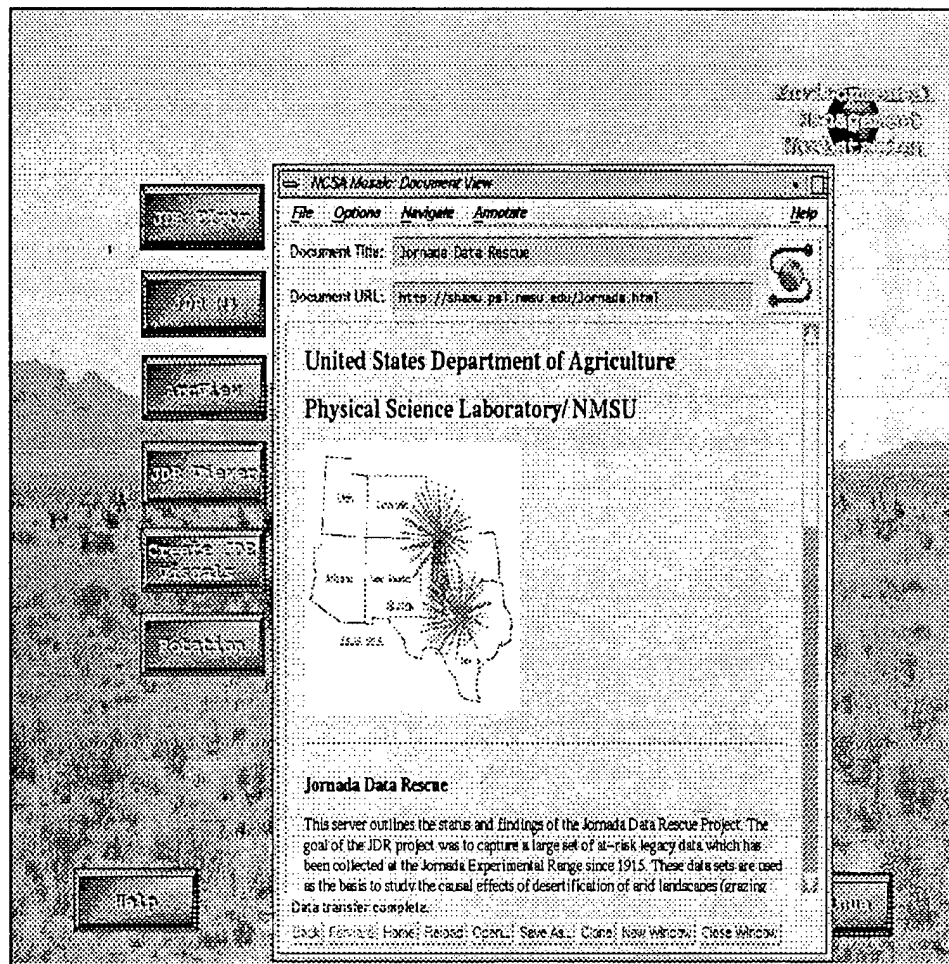

Figure 9. Environmental Management Workstation

#### 4.2.2 Procedures

The Global Positioning System (GPS) constellation consists of 24 satellites orbiting the earth twice a day at an altitude of 20,200 km. The satellites are high enough that they can avoid line-of-sight problems encountered by land-based navigation systems, and they use technology accurate enough to pinpoint positions anywhere in the world. The GPS is based upon satellite ranging, a process of determining a position on the earth by measuring the distance from that position to a group of satellites in orbit. That distance is computed within the GPS receiver by determining the length of time it takes a radio signal to reach the receiver from the satellite. There are high-precision receivers capable of centimeter accuracy and hand-held receivers capable of 3-5 meter accuracy, both with a differential correction.

Differential GPS methods have been used by land surveyors for several years to calculate positions. These measurements are based upon GPS data collection at a stationary location using a reference receiver. This information is then combined with the very precise knowledge of a reference point or "benchmark" and the use of a complex computer program. A GPS receiver placed on the ground at a known location (static reference) can be used to determine exactly what errors the satellite data contains. The reference receiver can then transmit an error correction message to any other GPS receivers that are in the local area, and these receivers can use that error message to correct their position solutions. The concept works because the satellite's altitude is so high that any errors measured by one receiver will be almost exactly the same for any other receiver in the same locality. Because of the simplicity of the GPS signal transmitted by the satellites, this single correction factor effectively provides for all of the possible errors in the system, whether the errors are from receiver or satellite clocks, satellite position, or ionospheric and atmospheric delays.

The background data capture procedure consists of the following phases:

- Historic Quadrat/Data Set Geopositioning
- Incorporation of Data Sets Into GIS

#### **4.2.2.1 *Quadrat Geopositioning***

Determined and recorded GPS locations for 13 historic quadrats:

- Located the 13 quadrats and completed archiving of position data.
- Collected positions using Trimble Navigation Pathfinder Basic Plus® receiver with an external antenna.
- Optimized equipment for maximum accuracy.
- Performed differential correction for all positions and output the results as a GIS point file.
- Used the GIS point file to generate an ARC/INFO® coverage of the quadrat locations. The quadrat locations included quadrat name and UTM coordinates.

#### 4.2.2.2 Data Set Incorporation into GIS

The following data sets were incorporated and registered into the ARC/INFO® GIS:

- USDA Agricultural Research Service (ARS):
  - Pastures - pasture boundaries for the JER
  - Rain gauges - rain gauge locations for the 34 standard rain gauges on the Jornada
  - Water wells - well locations for the JER
  - 1920s Vegetation - digitized vegetation map based on a survey conducted by the USDA in the late 1920s
  - Soils - four 7.5 minutes quadrangles digitized from the Dona Ana County Soil Survey digitized by San Diego State University (SDSU)
  - Elevation - four 7.5 minute quadrangles digitized from topographical sheets

Appendix I contains a representative sample of the data suitable for developing GIS backgrounds to support habitat interpolation and extrapolation.

## **4.3 Simulation/Model Investigation**

Plant growth and development modeling encompasses several disciplines including meteorology, hydrology, soil physics and chemistry, and plant physiology. To properly model plant growth and development, factors such as weather, water, soil attributes, and plant physiology must be taken into consideration. To this end, a proper inventory of software models would have to be taken, a task requiring months of research. Fortunately, researchers at the Duke University Department of Botany have performed this research and developed an inventory of applicable models (Chen and Reynolds, 1994). This inventory was then used to develop a series of models and modules and incorporating them into the Patch Arid Lands Simulation (PALS) model, which describes changes in plant production and species composition on arid landscapes due to environmental influences.

### **4.3.1 Procedures**

The PALS model is comprised of three major models in ascending order: a General Plant Simulator (GEPSI) model, an ecosystem community model (MONOMOD/MIXMOD), and a Simulation of Ecosystem Response to Elevated CO<sub>2</sub> and Climate Change (SERECO) model. Each of these three models is composed of smaller modules which describe certain specific activities within the ecosystem such as weather/plant canopy interactions, leaf photosynthetic activity, soil temperature and water relationships, and plant litter decomposition rates. Researchers at the Duke University Department of Botany have modified existing models, written new models, and incorporated these models into an arid lands simulation model. Section 4.3.2 describes each model in ascending order and culminates with the PALS model, a likely candidate to be used in the environmental modeling of the JER.

### **4.3.2 Model Descriptions**

#### **4.3.2.1 *GEPSI***

Plant growth mechanisms and the direct effects of CO<sub>2</sub> at the plant level have been stressed in the development of a general plant growth model called GEPSI. In order to adequately describe plant growth activity, it was necessary to construct generic models of leaf, canopy, and whole-plant response to elevated CO<sub>2</sub> and climatic change. This construction process requires that the modules in GEPSI (which is itself a module of the ecosystem model) contain general physiological mechanisms common to all plants. These mechanisms are biological processes such as photosynthesis and respiration activities and nutrient and carbon allocation (growth). These mechanisms are classified in this modeling effort as modules.

#### 4.3.2.2 *MONOMOD/MIXMOD*

Higher levels of organization, i.e., population, community, and ecosystem, are simulated through coupling of organism-process modules, as well as development of new modules which represent higher level interactions, such as competition, herbivory, and decomposition. The MONOMOD/MIXMOD model is an improvement on an earlier plant community model which incorporated generalized growth responses of plant functional groups to a series of environmental variables (light, temperature, soil water, and nitrogen).

#### 4.3.2.3 *SERECO*

At the ecosystem level, the translation of CO<sub>2</sub> effects and other aspects of climate change throughout the ecosystem, including feedbacks and constraints to system response, are stressed. SERECO is a general ecosystem model utilizing a plant simulator (GEPSE) as the central component. One version of SERECO that is applicable to this report is the PALS model, which describes plant/environment interactions within an arid environment.

## **4.4 Ontology of Habitat Classifications of Jornada Data**

One of the objectives of the Information Support For Environmental Management project was to classify the vegetation using methods which allow repeated monitoring over the same locations. The classification method being tested requires satellite imagery (such as Landsat TM data), detailed field data, and geostatistics, a method of predicting distribution of a habitat feature, such as plant species.

### **4.4.1 Procedures**

Field data collection was accomplished by performing the following steps, and the location of 100 transects was done in the following sequence (image processing was done with ERDAS® Software):

- A subscene of the August, 1992 TM image was classified into five types using ERDAS® CLUSTER (an unsupervised method) over all seven bands.
- One hundred points were randomly located and weighted by the proportion of each of the five classes by use of the ERDAS® RANDCAT subroutine.
- A transparency was printed to fit over a color, infra-red photo of the study area. From these points, distance and compass readings were estimated, paced out, and located on the study area. Labeled reinforcement bar (rebar) posts were placed for each transect.
- At each transect post, Daubenmire plots were placed and read in two of the four cardinal directions (determined randomly) for 50 paces. Reader, date, and direction were recorded for each half of the transect data, along with canopy cover classes by species per plot. Plots were numbered from the transect center. This spatial location information is required for geostatistical analysis.
- All transect posts were positioned by use of GPS technologies. The position results being used are in UTM coordinates with 1-3 meters accuracy after differential correction to base station data.

The geostatistical method requires knowledge of where a feature (plant) is located on the landscape, as well as its attribute (canopy cover). With this position and canopy cover, application of the geostatistics will describe how the canopy cover of a specific plant species varies over short to long distances in these two pastures. In statistical language, as distance increases between two points of interest (i.e., plant species), variation increases. However, spatially distributed data (such as canopy cover) behave more like random rather than mathematical variables. These types of data are more appropriately analyzed by regionalized

variable theory. Kriging is a stochastic method of analysis based on variable theory. In addition, kriging has direct application to classification and mapping of habitat attributes (Oliver and Webster, 1990). Kriging depends on a weighted value calculated from a property's location in space and the linear distance from an origin to the point where the variation of the property reaches a level where it does not increase anymore (or begins to decrease or oscillate significantly). The kriging method allows prediction of a plant species' extent or distribution. Essentially, this is an addition to the many vegetation mapping methods. However, combining these field efforts with a parallel geostatistical analysis of the TM subscene of the study area should allow a reduction in the quantity of field data required. Once the image "pixel" values' variance over distance are calculated and modeled, and the data are kriged, the baseline information is established to combine the field based model with that of the satellite model.

From these assumptions, it was determined that kriging provides the best metric to analyze the data sets.

In the case of an undersampled variable, such as the field data, it is feasible to predict values of this variable at unsampled locations by geostatistically modeling the undersampled variable with a higher density, correlated variable. Model parameters of these two kriging analyses can be combined using co-kriging (a type of autocorrelation analysis), a method of using the covariance matrices of each of the initial modeled variograms (field data and imagery), and deriving a common model, based upon a cross-variogram. The co-kriging results will be used to produce a map of the vegetation in the study area, which can be field tested by going out to specific locations and comparing the map results to vegetation actually existing on the site.

A map of the vegetation is completed at this point in the analysis, but further refinement of the mapping methods is available using the geostatistical method. This method provides the option of "jackknifing," which is an advantage at this stage of analysis. "Jackknifing" enables testing of the final classification (kriging or co-kriging) by reducing the number of original sample points, while still retaining a stable classification. The value of using satellite imagery for mapping landscape characteristics is apparent, although future analyses will continue to require field data collection. Reducing the amount of detailed field measurements necessary to generate valid thematic maps using correlated satellite and field data with the geostatistical method increases the efficiency of methods for monitoring arid and semi-arid lands.

Appendix J contains a sample set of habitat classifications, along with sets of characteristic indicators.

## **4.5 Conceptual Framework for Arid-Land Characterization**

### **4.5.1 Field Mapping System**

#### **4.5.1.1 System Description**

Since Range Management is a field science, a field mapping system was required for this project. In order to maximize the use of commercial hardware and software, the following system was selected.

A charge coupled device (CCD) black and white Dycam camera, a Magellan GPS receiver, and a 486 laptop computer were integrated for collection of field data at the JER. Commercial off-the-shelf (COTS) software (Geolink®) was used which permitted the integration of digital imagery with GPS.

#### **4.5.1.2 Procedures**

The demonstration was designed to evaluate the advantage of collecting images in a digital format for subsequent analysis in the laboratory. Images were acquired, classified as to vegetation type, and stored and copied for dissemination to project participants. Actual operation of the camera involved the following steps:

- Camera software integrated into the laptop allowed for keyboard shutter operation, which was convenient for aerial camera shots.
- Camera shots of vegetation were both oblique and the best approximation of nadir (i.e., that position directly beneath the observer). Quadrat shots were taken of *Prosopis glandulosa* (mesquite), *Bouteloua eriopoda* (black grama grass), *Gutierrezia sarothrae* (snakeweed), and miscellaneous mixed species.
- GPS signals were stored for later processing.
- Images were downloaded from the CCD camera at 9600 baud. Each black and white scene required approximately 500 kb of disk space. Thirty-two scenes can be stored in the camera before being downloaded to the laptop.
- The system required an extendable pole to achieve a one-square-meter field of view. One-meter-frame grids were subdivided into one-decimeter squares for the vegetation assessment test.

- Camera images were stored as TIF image files and later processed in a COTS image-processing system. The attempt was made to classify the images into unique clusters which could be transferred into a GIS.

## 4.5.2 Interpolation/Extrapolation Approaches

### 4.5.2.1 Introduction

Biological systems are much more complex than ordinary physical and chemical systems. Everyone today agrees that organisms are made from ordinary matter and that they obey rules of physical and chemical laws. However, the methods and approaches used in the scientific study of organisms relative to those used in, for example, classical physics, are modified by the organisms' complexity. The degree to which biological sciences differ in respect to classical physical sciences varies again among biological disciplines.

Molecular biology resembles "hard sciences" most in that everyone agrees on its single goal--to understand the heredity and function of cells in terms of chemistry and physics--and a limited number of established methods. Additionally, it rests on two very fundamental laws--the double helix structure of DNA and the four nucleic acid bases--which immediately makes it amenable to a host of analysis techniques.

Ecology is the study of the principles that govern temporal and spatial patterns for assemblages of organisms and their interactions with the environment. There are several problems with ecology that pertain to scientific methodology. First, ecology is a "pluralistic" science, in that it depends upon a wide variety of methods and approaches, which is primarily a question of scale. Another problem is that biological phenomena are a function of historical stochastic events and evolutionary events which are difficult to ascertain. Also, ecology encompasses a broad range of biological organization levels, from the organism through the population to communities and entire ecosystems, and a tremendous range of spatial and temporal scales.

### 4.5.2.2 Scale

Scale refers to the spatial or temporal dimension (e.g., size of area or length of time) of an object or process, characterized by both grain (the finest level of spatial or temporal resolution available within a data set) and extent (the size of the study area or the duration of the study). Thus, manipulations of grain and extent are a means of translating information between the time and space scales. Larger scales can be reached by increasing the extent of the observation set; smaller scales can be distinguished by making the observation set more fine grained (Turner, 1989). For example, Figure 10 shows a space-time diagram of the spatial and temporal scales at which ecological and atmospheric processes operate.

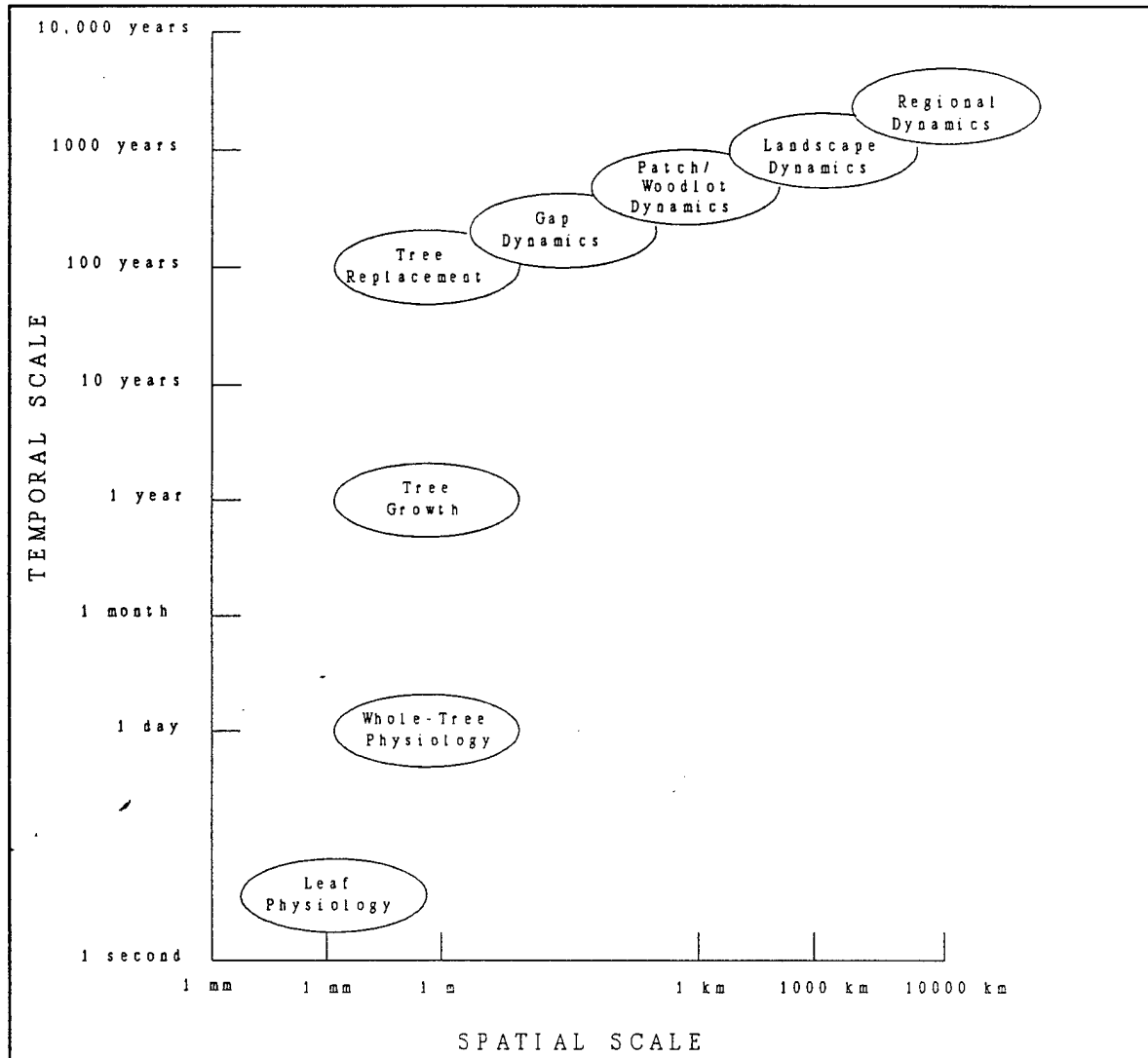

Figure 10. Time-Space Diagram

Time appears to be a unidirectional continuum, but is actually perceived with the same variation by which space is. Scales of time and space are widely different for dissimilar organisms. What a universe is to a protozoan, a water drop is to an elephant. What a generation of time is to an elephant represents about  $10^5$  generations to the protozoan. Biologists who study whole organisms and ecological systems can make generalizations from such observations which are valid for all organisms. There are many functional and structural constraints which pertain to size and time.

The fundamental challenge of biological modeling is to develop a general theory of scale that can guide the aggregation and extrapolation of fine-scale understanding to larger scales, and

to suggest hypotheses and methods for the direct investigation of large-scale phenomena. The study of these issues is addressed by the problem of scaling, which may be defined as the identification of guiding principles allowing the combination of data and models at different spatial and temporal scales and to extrapolate between scales.

It is ideal to model at managerial time scales (from days to years) for typical exploited ecosystems (e.g., grazing). The spatial scale is mainly dictated by monitoring methods which are currently at landscape scales (involving quadrat, transect data integrated with remotely-sensed vegetation, soil and climate data).

#### **4.5.2.3 *Flows and Cycles***

Matter or energy is said to be "cycling" when it sits in storage from one time to the next. Energy and materials cycle, as well as flow out of ecosystems. In general, inorganic nutrients cycle very efficiently, whereas energy cycles relatively inefficiently. A generalized static model of energy/element flows and cycles in an ecosystem is shown in Figure 11 (Odum, 1983). Note that the pathways for nutrients and energy are different. Energy enters such systems as fixed solar energy and exits as heat.



analysis of the entire flow of energy through specific systems, and 3) restriction of the consideration to one of energy flow between trophic levels. One of the most popular real test cases, used for exemplifying and comparing various energy flow analysis methods, is the one on intertidal oyster reef in South Carolina (Ulanowicz, 1986). Figure 12 shows the flow diagram of this ecosystem. However, an analysis of the community or ecosystem purely in terms of the transfer and transformation of energy is an oversimplification. It is only an initial approximation.

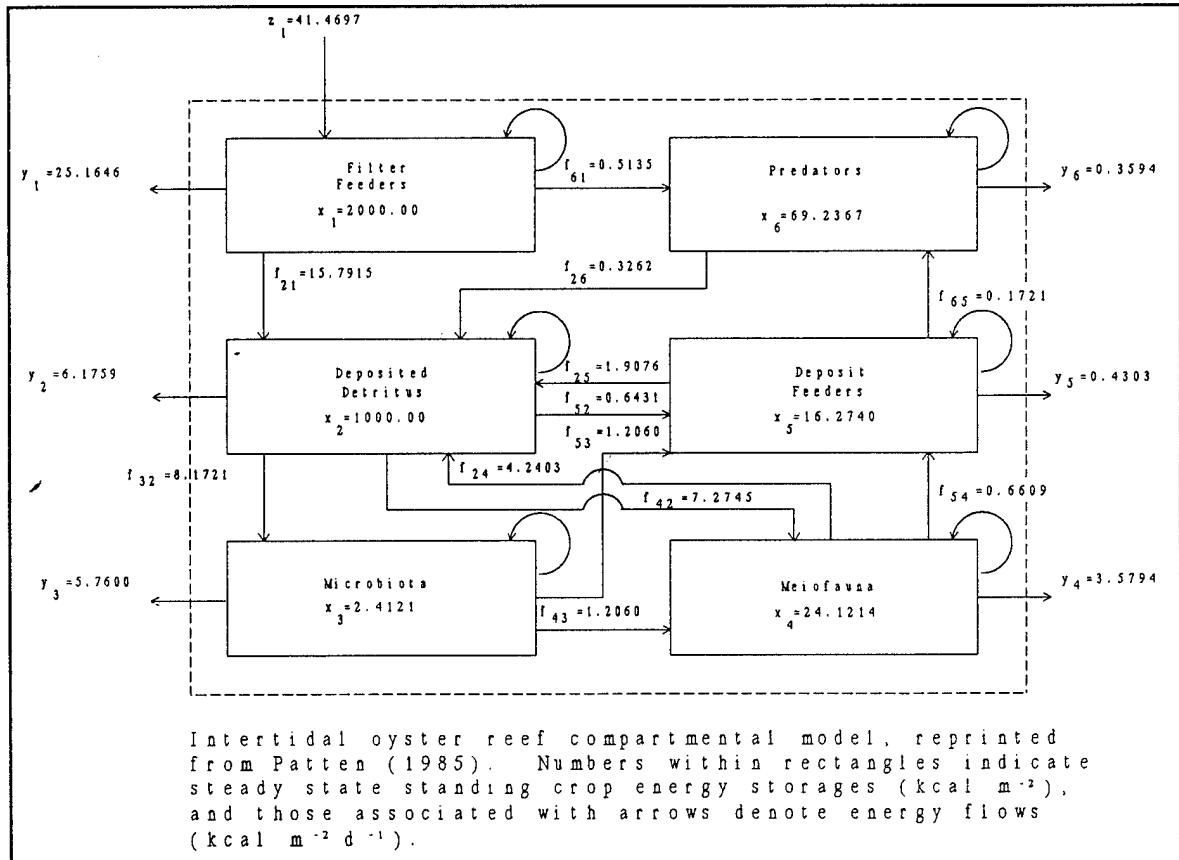

Figure 12. Flow Diagram, Intertidal Oyster Reef

Maintenance of life depends on a wide variety of nutrients. There exists a "finite" and specified amount of each nutrient within the system which cannot easily be replenished. Some of these nutrients are potentially limiting. The fundamental law of nutrient cycling is found to be that the capacity of a system to recycle materials is directly dependent upon the availability of "free" nutrients (not bound into plant or animal tissue). The study of most of these nutrient cycling laws falls under the methods of biogeochemistry.

Energy flow models are very elegant for analysis and simulation purposes due to their inherent physical and quantitative nature, but as seen above, are only a first approximation. In addition, they have enormous overheads and inaccuracies in terms of measurement on arid lands due to sparse canopy. On the other hand, biogeochemical methods are appropriate for any site, but involve measurements at very large time scales and very small size scales.

#### 4.5.2.4 Ecology Studies

Population ecology attempts to quantify the rates of immigration, emigration, birth, and death in order to explain what is influencing the timing and magnitude of the fluctuations, the mean level around which the population changes occur, and the role of factors which prevent over-exploitation and extinction.

A community food web describes the feeding habits of a set of organisms chosen on the basis of taxonomy, location, or other criteria without prior regard to the feeding habits among the organisms. Thus, it provides a partial description of the flows of matter and energy across and within the boundaries of a habitat. Community ecology attempts to describe, explain, and predict variation in the food webs of ecological communities (local assemblage of species populations).

An ecosystem is a community of organisms and their physical environment interacting as an ecological unit. Ecosystem ecology distinguishes two ways to study ecosystems: 1) an ecosystem consisting of a regional biota together with environment and 2) an ecosystem as an entity-environment unit.

Studies at the ecosystem level generally divide into autecology, the study of the interaction between a single species population and its environment and other species, and synecology, the study of interactions between multi-species and the environment.

Studies of communities, in principle, should bridge the gap between studies of species populations and attempts to understand the function of ecosystems. Between community studies and ecosystem studies there is an important transition from something strictly biological to something closer to geology. Again, the logical extension leads to studies in biogeochemistry.

Landscape ecology emphasizes large areas and the ecological effects of the spatial patterning of ecosystems. Specifically, it considers:

- the development and dynamics of spatial heterogeneity;
- interactions and exchanges across heterogeneous landscapes;

- the influences of spatial heterogeneity on biotic and abiotic processes; and
- the management of spatial heterogeneity.

Spatial heterogeneity is a notion characterized by the patchiness (complexity and variability) of some landscape property (e.g., plant biomass) that permits the detection and quantification of the magnitude and the rate of change of ecosystems.

For the most accurate modeling, there is a strong case for the biogeochemical approach at the ecosystem level. For the Jornada, Reynolds (Reynolds, Virginia, and Schlesinger, 1993; Jia-Lin and Reynolds, 1993; Li and Reynolds, 1993) has created a long-term program to explore this. But choosing which level of ecology to study, model, and simulate can also be dictated by the principle method used for monitoring and the form of the observed data. Having made the decision, which in this case will be the landscape level, it is necessary to make another decision on the essence of the modeling technique.

#### **4.5.2.5 Ecological Concepts**

Toward this end, some of the fundamental phenomena will be examined. These specific phenomena are examined because they feature the dynamical concepts and must be effectively demonstrated by any contending simulation model.

##### **4.5.2.5.1 Direct and Indirect Effects**

The distinction between direct and indirect effects can best be understood by examining the lessons from ecotoxicology--"If the direct, toxicological effects of pesticides on the growth, survival, or reproduction of organisms may be called direct or primary, irrespective of type of exposure or period until effects are observed, then ecosystem changes that follow from these primary effects are termed secondary or indirect effects."

In other words, the type of biological interaction observed at a proximate level may become a qualitatively different type at a higher level of organization when all of the consequences of context are considered. The nine qualitative interaction categories are nihilism (predation), competition, commensalism (one-side positive symbiotic), anabolism (growth), altruism (selflessness), mutualism (two-side positive symbiotic), amensalism (one-side negative symbiotic), dissipation, and neutralism. It has been discovered through network ecology that direct interactions are limited to nihilism, altruism, and neutralism and that competition, mutualism, commensalism, amensalism, growth, and dissipation are all interaction types that arise strictly as consequences of indirect effects. It has been shown that indirect to direct effects ratios tend to increase with increased complexity, nutrient cycling by use of the Higashi parabolic rule (Higashi and Burns, 1991).

#### **4.5.2.5.2 Island Biogeography**

A community is always in a state of flux--species are continually lost and replaced. The community is constantly changing under selection pressures acting upon them. New species become available for new colonization of the community. Local species populations are continually becoming extinct. The community may be recolonized by other representatives of the same species, by other existing members of the community, or by a new species altogether. The community remains in balance as a result of an equilibrium between continuous colonization and extinction, even as its structure changes constantly. The theory of island biogeography attempts to explain the balance between immigration and extinction in terms of this equilibrium and attempts to predict the rates of approach to the equilibrium. Community assembly mechanisms attempt to generate patterns and properties reflected in this equilibrium model and also are seen in a variety of natural communities. It is possible that assembly rules can be recognized by observing certain consistent events among a set of trajectories, thus developing an assembly trajectory catalog.

#### **4.5.2.5.3 Succession**

Succession is a directional change in community structure and function, an additional change whereby all of the minor changes of structure and operation accumulate over time so that the community itself develops a different basis and function. Succession may be viewed as the development of a community from its inception, through a series of recognizable intermediate, "successive" stages to a climax, which is considered the most stable community that can exist in that environment. Succession is also a convergent process. Despite very different starting points, the end point of progression remains the same. During the process of succession, nutrient flow slows down and the community becomes more complex and diverse. All theories of succession attempt to explain this variety of patterns either in terms of the biological properties of individual species or a statistical phenomenon. Horn and Johnson (1990) have treated succession as a stochastic Markovian process independent of biological reasons due to strong properties such as directionality, convergence, stability to disturbance, and rapid changes followed by slower ones.

#### **4.5.2.5.4 Coevolution**

Evolutionary change influences the adaptiveness of individuals to their particular niches, as well as the dynamics, structure, and function of entire systems. Coevolution arises when two or more species serve to influence each other, and form an interactive, coadapted system. For example, grazing by large herbivores has a coevolutionary effect on the structure and species composition of the vegetational communities on which the herbivores rely by producing defenses in the plants under selection pressure. Selection pressures acting on the partners of a coevolutionary relationship will tend to direct adaptation and counteradaptation towards an ultimate relationship of minimum disturbance: each adaptation "calculated" to

provoke minimum counteradaptation from the partner. Also, coevolution does not exist only between pairs of species, but exists between all of the members of an ecological community.

#### **4.5.2.5.5 Stability and Biodiversity**

Species diversity is a measure of the variety of different animal and plant species of a community. Some well-known observations that have been made with respect to species diversity are a gradual increase in diversity by moving toward tropical regions, increase in diversity through ecological succession, and increased diversity in island regions. A number of theories have been proposed to account for differences in diversity. Some of these hypotheses include diversity as a function of time, niche heterogeneity and complexity, community productivity, and biotic interactions. All of these theories are compatible, and it is probable that diversity is a complex function of all of these factors along with a few more.

Ecological stability is the dynamic equilibrium of population, community or ecosystem size and structure. The phenomenon of stability is comprised of three parts: constancy, the lack of change in parameters; resilience, the ability to recover and continue from disturbance; and inertia, the ability to resist such perturbation initially.

It has been observed that environmental constancy permits the development of greater species diversity. One of the most consistent effects of environmental disturbance is to increase the variation in the relative abundance of species within a community. May (1981) lends strong support to the thesis that species diversity within a community is a function of environmental stability.

#### **4.5.2.6 Modeling**

##### **4.5.2.6.1 Biogeochemical Plant Growth Model**

###### **Introduction**

The following model has been assembled by Reynolds et al. (1993). It is similar to most soil-water-vegetation modeling efforts being carried out at many sites (e.g., ZELIG and FORET), and is currently implemented as an object-oriented system at a plant-patch scale.

###### **System Description**

The whole plant growth model is divided into two major parts--the environment and the plant (Figure 13). The environment contains the driving forces to plant growth. Plants face an above-ground aerial environment and a below-ground soil environment. The above-ground aerial environment constitutes the weather conditions above the canopy (weather) and vertical

profiles of micro-meteorological variables in a canopy (micro-weather). Weather employs annual, daily, and diurnal patterns generated from formulas and micro-weather incorporates a full model of radiation transfer in a canopy. The soil model is based upon solving partial differential equations for heat, water, and nutrient movement in the soil. The plant model consists of a canopy and a root system. The leaf model incorporates the responses such as photosynthesis, stomatal conductance, and transpiration. The root model incorporates the characteristics of root water adsorption and nitrogen uptake.

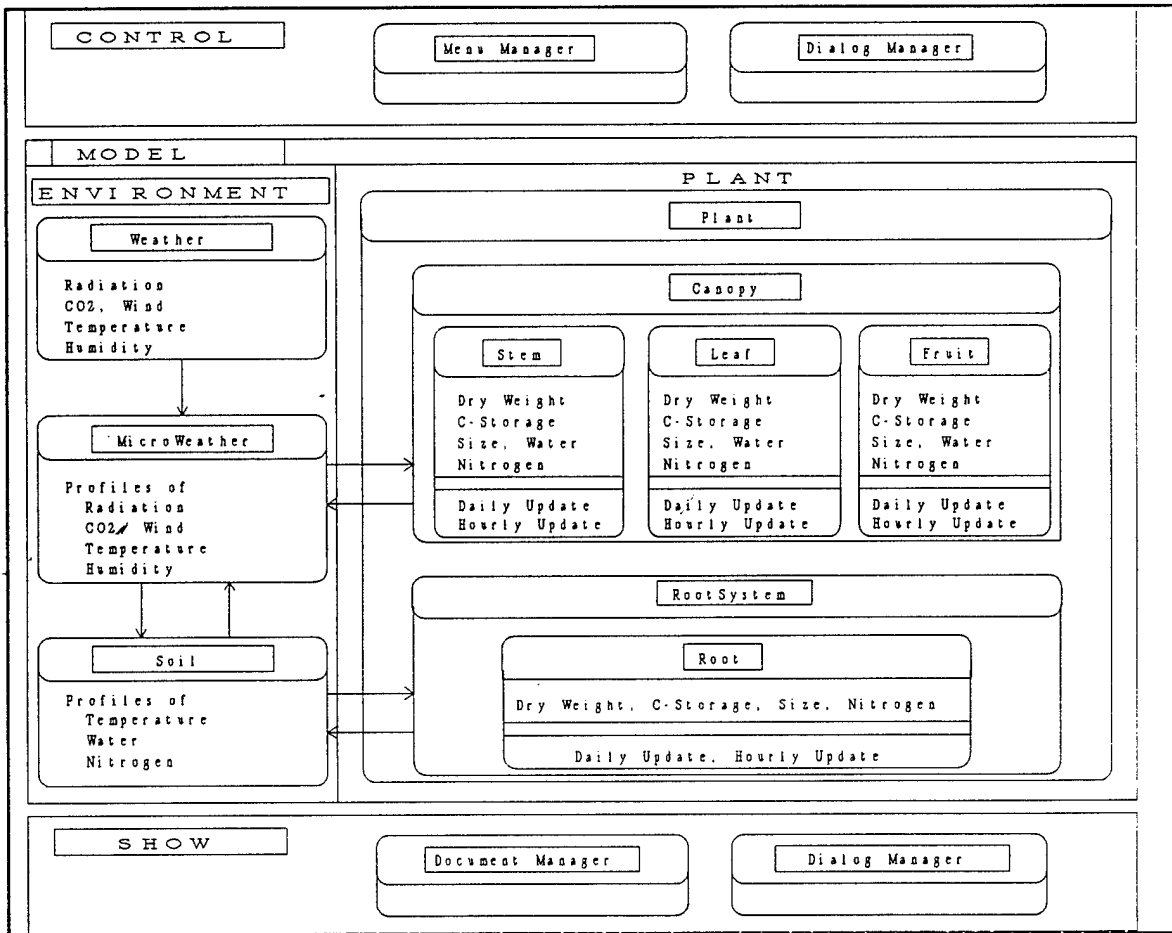

Figure 13. Whole Plant Growth Model

## *Procedures*

Plant growth modeling encompasses several disciplines, including meteorology, hydrology, soil physics and chemistry, and plant physiology. The following are the classes corresponding to conditions and organs affecting plant growth.

### *Weather*

The key weather variables are daily total short-wave radiation, daily highest and lowest temperatures, day length, daily mean air humidity, total daily precipitation, daily mean wind speed, and daily mean carbon dioxide concentration. The annual courses of these variables have to be formulated.

Short-wave radiation is based on the solar constant, the sun zenith angle and extinction coefficient of the atmosphere. Daily temperatures, humidity, and precipitation are all averaged uniformly from measured values.

### *Micro-Weather*

The structure of the canopy strongly affects the micro-weather conditions within the canopy. The driving forces behind canopy photosynthesis and transpiration are carbon dioxide, temperature, vapor pressure, and radiation. The profiles of these variables in a canopy are determined by transfer of energy, momentum, and mass.

Radiation transfer is described by Norman's bi-directional transfer model (Norman, 1982). The transfer of momentum, heat, and mass requires Goudriaan's description of aero-dynamic processes in the canopy.

### *Soil*

Soil layering provides physical and chemical conditions at each layer within a soil column. It defines the framework for heat transfer, water movement, and nutrient dynamics, modeled as one-dimensional partial differential equations. Several types of soil characteristics are studied.

### *Leaf*

A leaf continuously exchanges gas and energy with the environment surrounding it. Gas exchange is a leaf's most important function. The gases considered are water vapors and carbon dioxide. The flux of carbon dioxide and water vapor between the open air to the leaf is calculated based on Ohm's law. The energy inputs to a leaf are short-wave radiation,

thermal radiation from the sun and sky, and thermal radiation from the soil surface. The leaf loses energy through thermal radiation and exchanges energy with the environment in the form of sensible and latent heat fluxes.

### ***Stem***

The stem primarily performs stem growth, and to a lesser extent gas exchange. In gas exchange, photosynthesis is ignored and only maintenance respiration is considered. Stem growth consists of changes in volume, area, length, and diameter. Once the shape of the stem segment is modeled, the remainder can be derived from the elongation rates.

### ***Root***

Roots are either active or inactive. Depending upon whether the root is active or inactive, uptake of water and nutrients are either active or not, and respiration rates are either high or low. Uptake of water is calculated by Ohm's law and uptake of ammonia and nitrates flow through Michaelis-Menten dynamics. A certain biomass of active roots are used to form suberized root.

#### ***4.5.2.6.2 Community Food Web Model***

A food web is a group of different types of organisms and a relationship that shows the types of organisms, if any, that each kind of organism in the group eats. A community food web is one whose vertices are derived by selecting, within a habitat or set of habitats, a group of types of organisms on the basis of taxonomy, size, location, or other criteria, without prior regard to the eating relationships among the organisms.

There are several models that have been used to describe the structure of community food webs. For all of these models, the ratio of links to species turns out to be a crucial parameter for estimation. One of the most desirable models, the cascade model, assumes that species are well-ordered in some way, i.e., they are arranged in a hierarchy or cascade of potential feeding relationships. There is a certain probability that higher species will feed on lower species, but there is no probability that lower species will feed on higher species. Thus, the assumption that a certain potential feeding relationship becoming an actual feeding relationship is random. According to the model, the central assumption is that species are arranged in a hierarchy so that cycles are absent. A second assumption of the cascade model is that the probability of a link from one species to another above it in the hierarchy varies inversely as the number of species in the food web. This assumption implies that the total number of links in a food web should be directly proportional to the total number of species.

The cascade model analysis results in an expected number of chains of each length in a food web for a given number of species. Monte Carlo simulations give a goodness of fit between

the numbers of chains observed in an individual web and the numbers expected from the cascade model. The cascade model therefore is an exactly derived theory, and is one of the best predictive models for the structure of food webs.

#### *4.5.2.6.3 Compartmental Growth Model*

An ecosystem is a community of organisms and their physical environment interacting as an ecological unit. The ecosystem as a paradigm has become structured through network models. There is a diversity of network approaches addressing different theoretical issues. The Dynamic Resource Perturbation (DRP) model applies economics-like optimizing principles to predict ecosystem behavior at managerial time scales under changing resource constraints.

The optimizing principle states that a self-organizing community flow network, over an adequate time interval, will optimize its optimand subject to hierarchical, thermodynamic, and environmental constraints. Three types of optimands used are ascendancy, exergy, and energy intensity. Among these, energy intensity has explicit dependence upon stocks, flows, and time. Energy intensity is system-wide, has a significant variation among compartments over time, and is strongly suggestive of price in economic systems. Also, maximization of the products of price and output is a useful predictive tool in general.

The model is based upon a discrete input-output compartmental organization with assigned stocks and flows from calibrated measurements. The goal is to determine the maximum output allowed by the existing stocks, and hence the maximum potential growth, of each compartment. Optimization selects an appropriate output level that avoids structural imbalance; thus, there is an interaction of the optimizing principle and a dynamic model of growth and decline. Energy intensity is calculated at each step and is used as an input to the optimization process. Figure 14 illustrates the algorithm for optimization used in the compartmental growth model.

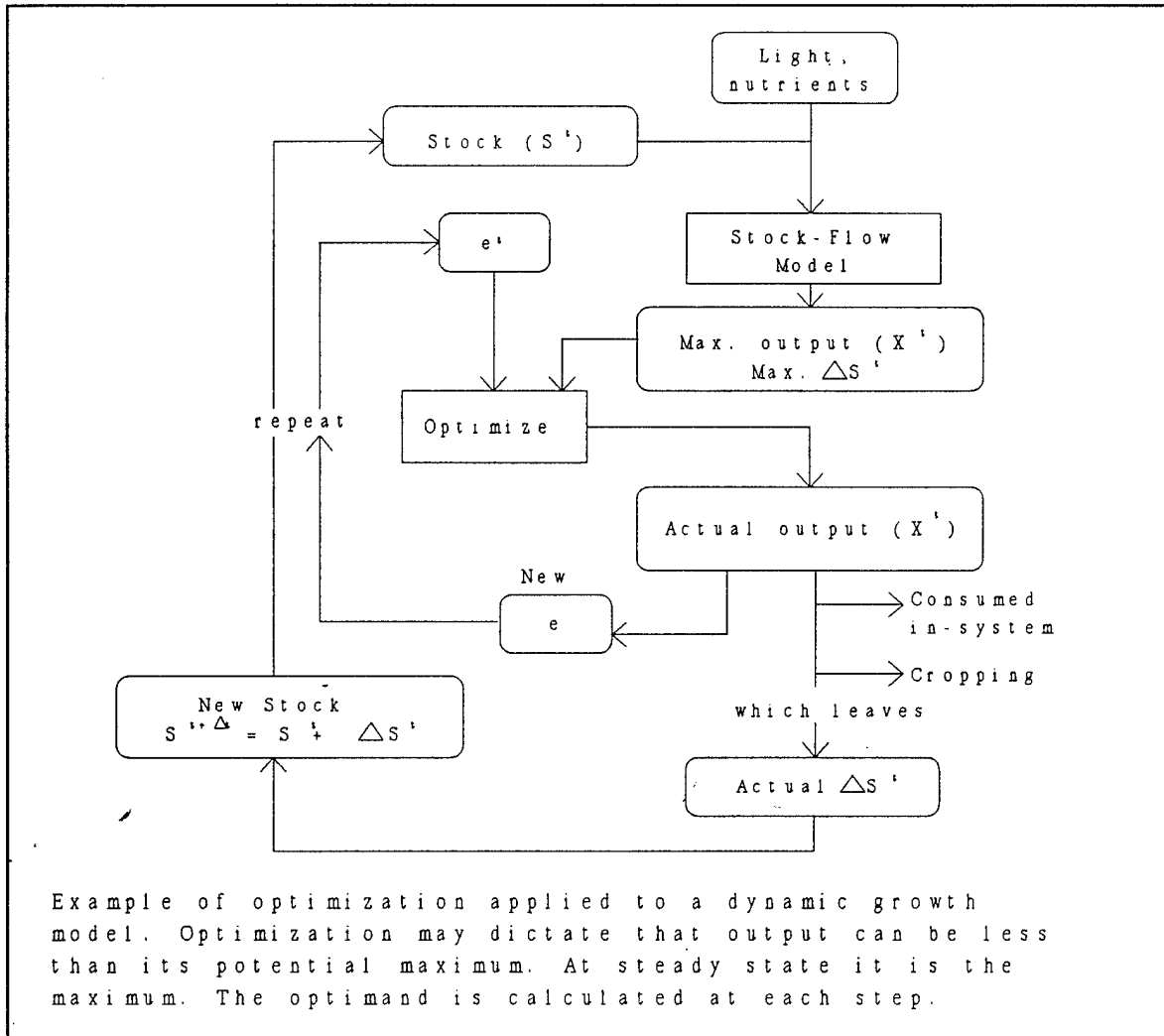

Figure 14. Algorithm for Optimization used in the Growth Model

The DRP model has a distinct quality of object-orientedness because the compartments form well-defined objects and optimizing messages are transmitted between compartments for a system-wide evolution to take place as a result of optimization.

#### 4.5.2.7 Biogeographic Classification and Artificial Ecosystem Simulation

##### 4.5.2.7.1 Introduction

Information processing using GIS attribute data is useful when reasoning about multi-scale phenomena caused by the neutral nature of modeling. Initial definition of systematic techniques for observations of patterns and generation of new patterns is necessary, which implies a requirement for an ontology, a language used to describe existing patterns, and a

simulation model, a language to generate new patterns. In order to build an ontology, two problems must be addressed--class determination and hierarchy construction. Two powerful techniques from Artificial Intelligence (AI), patterns recognition and matrix analysis, will be used to address these problems.

The patch is a basic defining unit of an evolving ecosystem. This choice is based on qualitative and phenomenological considerations such as detectability and reproducibility. So, in some sense, the patch is the amino acid of community organization, the building block of ecology. A patch may now be technically defined as a relationship between the set of observed species and the set of all physically possible niches. This relationship in turn manifests, topologically, as a pattern of connectivity or a simplicial complex representation for the patch. A square lattice of interacting patches constitutes a mosaic and is denoted by a set of connected, incidence matrices. The information available from the ontology will be used to construct such patches and simulated interactions between the connected incidence matrices will be used to explore the dynamics of landscape change.

#### ***4.5.2.7.2 System Description***

The attribute vectors resulting from GIS overlays are decomposed into their principal components and clustered using nearest neighbor analysis. These clusters are evaluated for spatial indices and successively refined through training and testing by geometric classifier and manual overrides. The refinement eventually results in a set of ecologically-meaningful classes which are then hierarchically organized into a mathematically-indexed ontology by training a stochastic decision tree.

The ecosystem model is defined over a basic unit called a patch, which could typically be fragments from the ontology, representing some relationship between the classes. A spatial grid or mosaic of such patches denotes an evolving unit of the artificial ecosystem. The simulation model is a combinatorial dynamical system called simplicial glass, which has discrete space-time variables and continuous thermodynamic (information-theoretic) energy states. It evolves toward ground energy states through an optimizing schedule that exploits both evolutionary and variational principles. Patch ascendancy may now be understood as a function of optimizing trajectories. Figures 15 and 16 outline the overall architecture of the system.

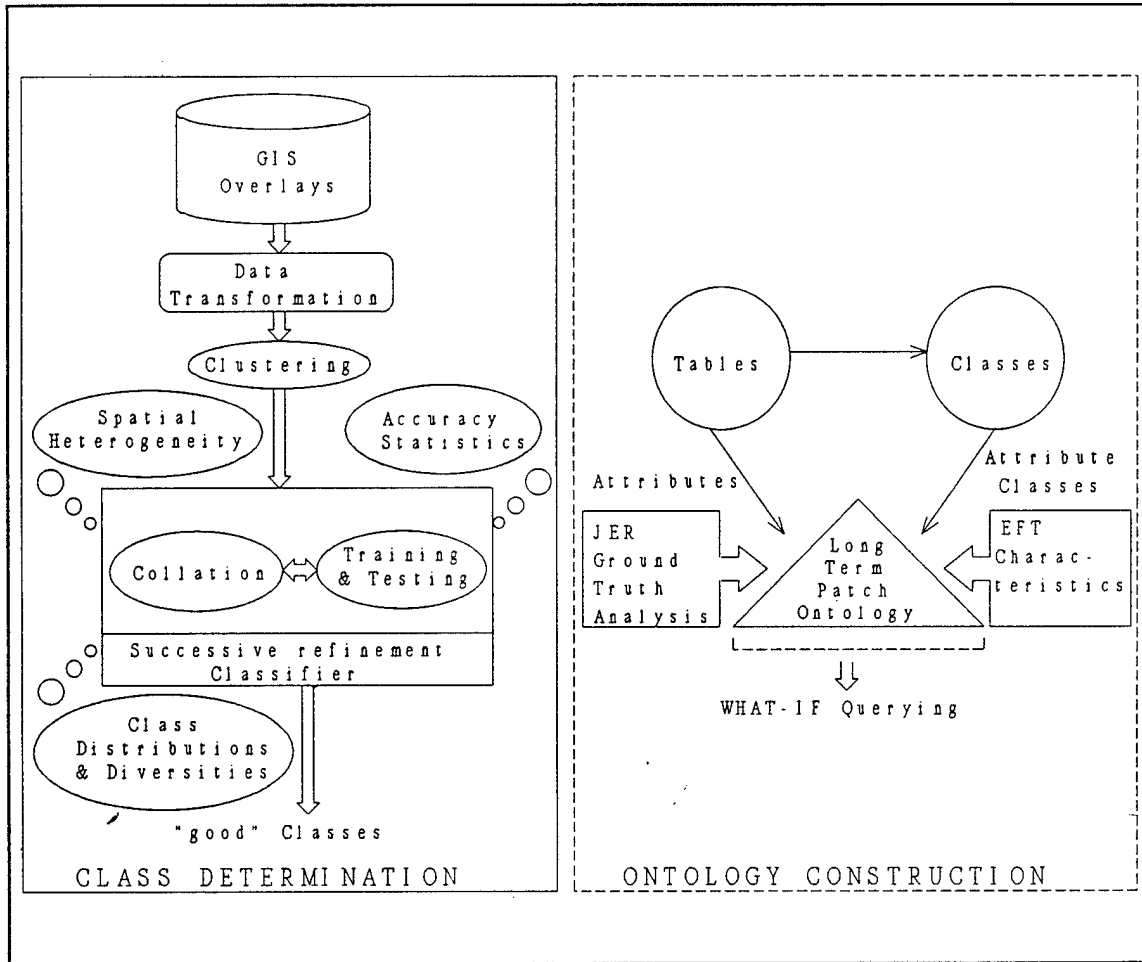

Figure 15. Ontology Construction Stages

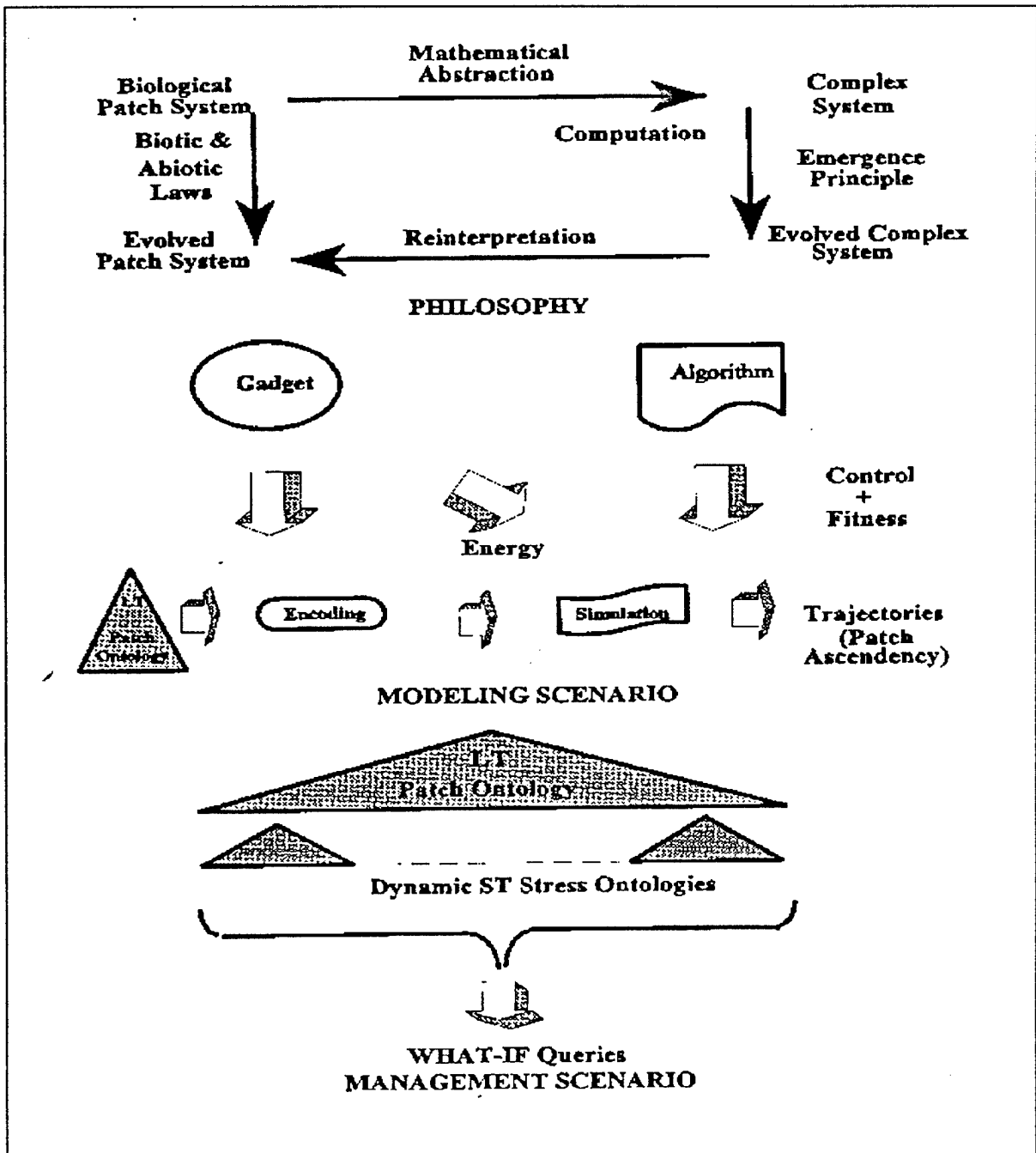

Figure 16. Modeling Process

#### ***4.5.2.7.3 Procedures***

Some of the techniques that are used to transform, cluster, train, and classify data are taken from well-known developments in algorithms for data reduction, pattern classification, and learning methods.

##### ***Singular Value Decomposition***

Singular value decomposition is a data reduction technique in which principal components are calculated for given set of vectors of a certain dimension. The theory holds that since a finite number of vectors will occupy only some subspace of the entire vector space, then by appropriate projection the dimensionality of the vectors can be reduced. This is accomplished by factoring out the singular value matrix (which measures the distance of each component from the actual subspace), nulling the errors beyond a given threshold, and re-multiplying the matrices to obtain a lower rank original matrix.

##### ***Nearest Neighbor Analysis***

Nearest neighbor analysis is the most popular clustering technique for a given set of real valued vectors. The Euclidean distance norm is used as the basis for aggregating vectors into clusters.

##### ***Bin Packing***

Clustering results in a hierarchy of vectors that are relatively ordered in terms of the distance norm. This hierarchy can be aggregated into classes (primarily parameterized by size) by bin packing methods, which are tree algorithms with logarithmic time complexity of creation and access.

##### ***Oblique Hyperplane Partitioning***

Once certain number of clusters have been formed, it is necessary to verify if the parameterization resulted in suitable classes. This can be accomplished by checking to see if the clusters can be geometrically partitioned by appropriate hyperplanes with a minimum amount of impurity (vectors of one class falling within the partition of another class) occurring. This is accomplished via training decision trees corresponding to the hyperplane partition structure by these vectors and then testing against some subset of the vectors.

### *Stochastic Decision Tree*

Once the classes have been verified as meaningful, the vectors are mapped back to the actual symbolic attributes. These attribute sequences in each class are then treated as representing sentences in some biogeographic grammar. A stochastic decision tree trains for such a grammar from a corpus of such sentences obtained by overall analysis of the overlay data (GIS coverages).

#### *4.5.2.8 Remote Sensing and Stochastic Landscape Simulation*

##### *4.5.2.8.1 Introduction*

Researchers at Oak Ridge National Laboratory have been successfully working with stochastic simulation models at landscape spatial scales and managerial temporal scales (Gardner et al., 1987). They have developed several well-tested, spatially-influenced stochastic simulations based on land-use data using a Markovian transition model with simple spatial influence (contagion) rules. Simultaneous analysis of spectral satellite data for semi-arid and arid land vegetation has been limited due to the small amount of phytomass and the large amount of bare ground. Vegetation contributes only a portion of the radiance value; soil background dominates any study. Several different vegetation indices (e.g., NDVI, SAVI, and Greenness Vegetation Index (GVI)) have been used to identify vegetation patterns in arid regions.

Multiple-year sequences of remote-sensing data can be used to provide estimates of transition frequencies between ecological states. These estimates can then be used as inputs for Markov models of succession in the ecosystem. This involves solving the problems of spectrally-separable states and deriving actual transition probabilities. Figure 17 shows how stochastic models operate at various scales.

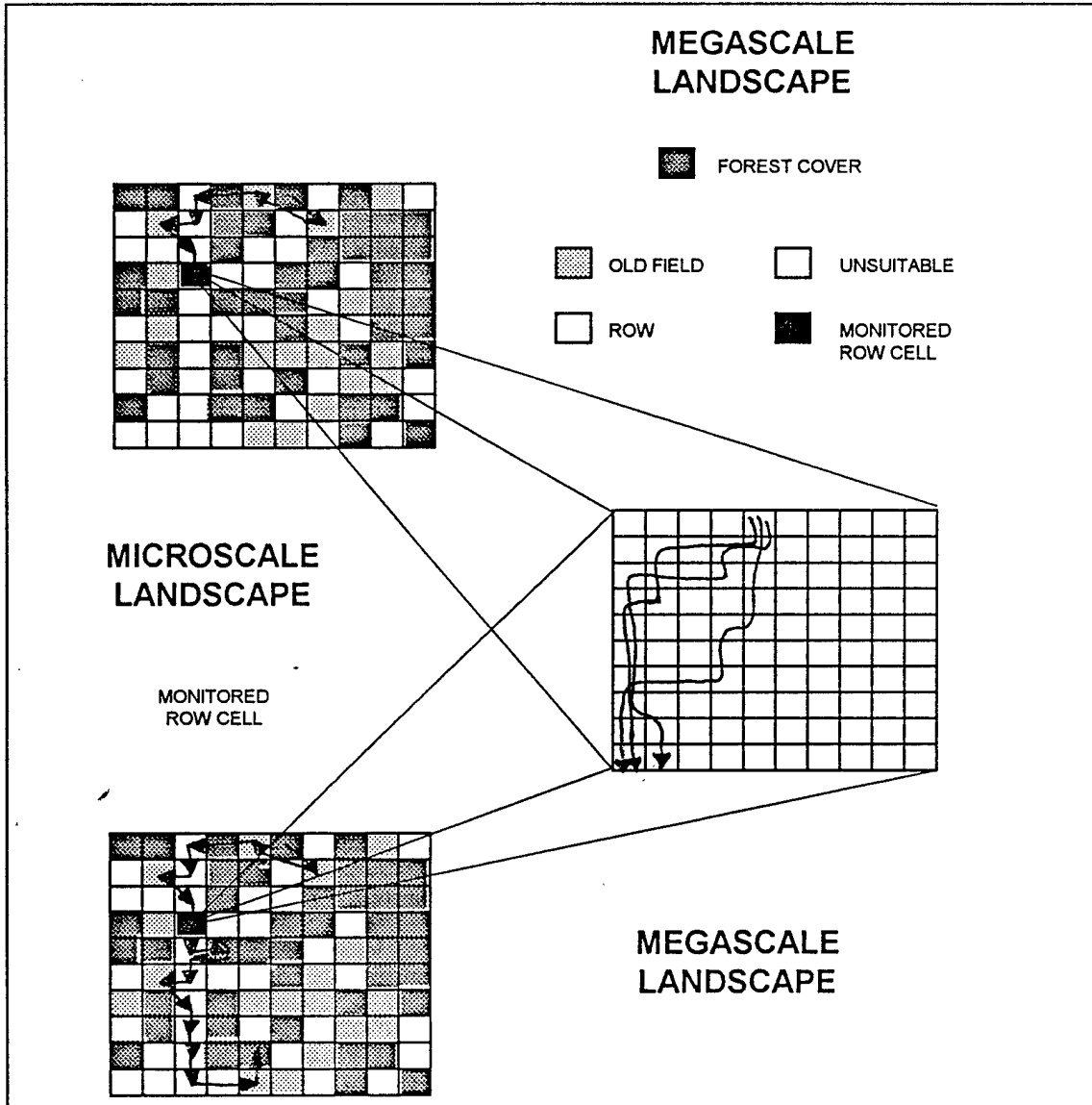

Figure 17. Patch Mosaic Landscapes

#### 4.5.2.8.2 Procedures

The following sections outline the issues relating to vegetation indices, including possibilities of deriving transition probabilities from them, and eventually utilizing them in spatial Markov models.

### *Spectral Vegetation Indices*

Two major influences render various spectral vegetation indices such as NDVI and GVI unreliable over arid rangelands: background sources of error due to soils and litter, and the moderate effect associated with standing dead vegetation such as yellow standing grass.

The soil background is a major surface component that controls the spectral behavior of all but the most dense of vegetation canopies. In order to overcome this, attempts have been made to model the soil brightness dependency of partially-vegetated canopy spectra so that a vegetation index could be developed that could account for dynamic soil-vegetation spectral behavior and which could be related to significant biophysical plant parameters. SAVI is one such method by which spectral indices may be refined or calibrated so that soil substrate variations are effectively normalized and are not influencing the vegetation measure.

Generalized vegetation index approaches exist that do not involve calibration. These approaches provide information on the relative amounts of cover present and relative change in cover through time rather than absolute values. The approaches are based on the assumptions that consistent relationships exist between the amount of cover and the vegetation index, and that consistency in those relationships is maintained over time.

### *Spatial Stochastic Simulation*

There are two methods of implementing transitions in a spatially explicit stochastic model of landscape change--pixel-based and patch-based methods (Plotnik and Gardner, 1993). In the patch-based model, patches are first categorized by clustering pixels, and change is evaluated for the patch units as a whole. Pixels and patches are assigned landscape-condition labels by overlaying several maps into a composite map. A matrix of transition probabilities is calculated by enumerating the various changes of landscape-condition labels pairwise through a series of multiple-year maps. To conduct a simulation, the transition matrix is applied to all of the pixels in a map.

Landscape changes are not strictly Markovian, i.e., the change of a cell's state is not simply a function of its current state, but is influenced by surrounding cells. Thus, there are spatial neighborhood effects. Additionally, the transition rates are not constant through time; therefore, dynamic transition probabilities are required. Also, defining states and obtaining transition probabilities by independent measurement are difficult tasks.

#### **4.5.3 GIS Products**

GIS products allow the visualization of the spatial and temporal variations in the base data sets. This is a prerequisite for analysis and synthesis of geographic data.

#### **4.5.3.1 Procedures**

ARC/INFO® macros running under the Unix Operating System on a Sun SPARC station were used to develop the GIS layers.

Data were provided to TEC for integration into the GIS. ARC/INFO® macros were used to process the following data for incorporation into the GIS:

- Study area rectangle - boundary location of 10,000-acre rectangle determined to be the focus of this study
- Quadrat locations - location of 13 quadrats found within the study area boundary
- Biotic spatial and temporal relationships within quadrangles
- Surface precipitation - based on USDA standard rain gauge data
- stocking rates - based on USDA stocking rate records

The macros and source code required to integrate the data sets are provided in Appendix H.

#### **4.5.4 Ft. Bliss and White Sands Missile Range Data**

An inventory was compiled for Ft. Bliss and White Sands Missile Range as a preliminary effort to ascertain the feasibility of applying the techniques and methods used in the JER study on military reserves. This inventory (separated by quadrangle coverage) of the available aerial coverages is included in Appendix L.

##### **4.5.4.1 Procedures**

Ft. Bliss was visited by several TEC researchers on two occasions. Resource management data needs were discussed in detail with several of the Environmental Division managers. Their needs center around training requirements for the base. Rapid data and field assessment are critical to effective management of Ft. Bliss. Data deemed important for collection include Land Condition Trend Analysis (LCTA), base mapping aerial photography, training impact assessments, grazing impact assessments, and other related data. There is a need for mapping of arroyos; however, the overwhelming size of the installation makes this impractical. It will be necessary to map vegetation communities in detail to effect change detection analyses of the landscape. There is no large integrated GIS above and beyond that which has been collected in the LCTA module. Monitoring the track and wheel vehicle activity on Ft. Bliss, using available on-board GPS, and providing the information to the

Environmental Division would be one way for collecting quantitative data in support of natural resource management decisions. Vehicle movement, in conjunction with change detection pairs of a landscape, would serve to better explain the ramifications of certain training activities.

The procedures for registering and integrating available WSMR and Ft. Bliss data into the Environmental Management Workstation would require the collection and collation of scattered data sets. These could be incorporated as ARC/INFO® GIS coverages. Additional data sets (Landsat-TM, Landsat-MSS, SPOT, aerial, etc.) are readily available and would need to be incorporated as a basic background data set.

#### **4.6 Applicability Study of FALCON Workstation**

The FALCON interactive analytic system was developed by Lockheed Missiles and Space Co., Austin Division, with consultancy support on the analysis of time varying data from the Computing Research Laboratory of NMSU. The system was designed for intelligence applications. In particular, FALCON was designed for time-varying situation analysis in law enforcement and low-intensity conflict.

The Physical Science Laboratory, in cooperation with CIERA and TEC, is proposing to develop a field-portable land management system that uses innovative field data-set handling devices. This system will be implemented using COTS technology, will employ user-friendly "visual" presentation methods, and will be prototyped using Southwest arid/semi-arid ecosystem data. It is anticipated that, in addition to being capable of ingesting locally-collected data, the system should be capable of accepting data from environmental networks that are currently being put into place. These include, for example, data from sources such as the National Spatial Data Infrastructure (NSDI), the Consortium for International Earth Science Information Network (CIESIN), special interest clearing houses, private sector databases, and electronic plant species compendia. Figure 18 describes the flow of environmental data in a FALCON-like integrated system structure.

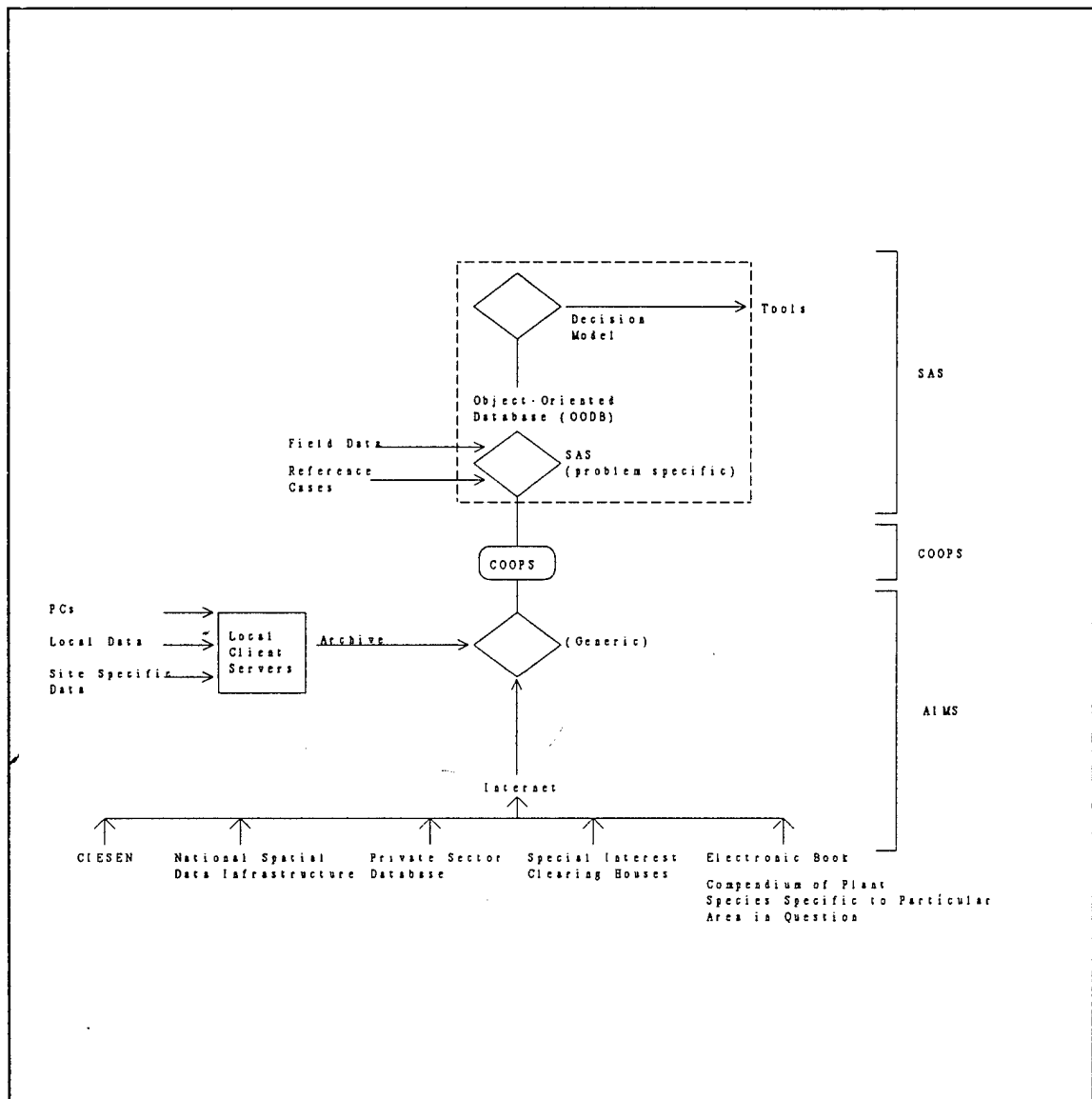

Figure 18. Flow of Environmental Data in a FALCON-Like Integrated System Structure

#### 4.6.1 System Description

##### 4.6.1.1 FALCON System Components

The FALCON architecture is an object-oriented, interactive intelligence system consisting of three major components. These three components are the Advanced Information Management

System (AIMS), the Cooperating Information Agents (COOP), and the Situation Analysis System (SAS).

#### **4.6.1.1.1 AIMS**

AIMS is a Lockheed-proprietary, knowledge-based, distributed data network that integrates recent advances in distributed database technology, logic-based query languages, network communications, and artificial intelligence. The combination of these technologies into AIMS provides for continuous improvements in site communications capabilities and revolutionary advances in state-of-the art data services.

AIMS has the critical responsibility of performing all necessary data gathering and preparation tasks. These tasks include:

- to act as the single interface to data sources and databases, information dissemination requirements, and media availability;
- to fuse information into intelligence products (reports);
- to provide high-speed data interchange within the system;
- to provide the analyst control over the information gathering functions;
- to transparently interact with standard data communications protocols

The AIMS is the functional heart of FALCON, as it continuously accesses and pumps relevant information through the COOP agents to the SAS.

#### **4.6.1.1.2 COOP**

The FALCON COOP agents allow analysts to control their own information needs. This is the capability that makes FALCON an active information management system rather than a conventional, passive information system. Certain queries, indications, and warnings may require that COOP agents actively seek out information and continue to do so until the information requirement is satisfied. COOP agents are in reality mental extensions of the analyst in that they automatically act on the analyst's behalf. Some COOP agents are always active as they continuously monitor information flowing from AIMS, while other agents are situation-activated whenever a predetermined condition arises. A brief description of the different agents is described below.

### *Analyst Input Agent*

This agent enables an analyst to benefit from all of the AIMS information processing capabilities. It is always accessible to the SAS analyst and serves as a powerful tool to support the analyst's specification of data requirements. At this level, data features include message type, message source, and type of data element; conditions pertaining to the preprocessing, formatting, and displaying of data; and mapping the arriving data into the analyst's application-specific data structures and databases.

### *Intelligent Query Agent*

This agent provides an interactive interface that enables the user to construct queries in a natural fashion. The agent insulates the user from having to distinguish between different access mechanisms such as broadcast data streams or application-specific databases.

### *Product (Reporting) Agent*

This agent supports analyst product generation and reporting by applying the Analyst Input Agent in reverse. The Product Agent is passed information pertaining to the data elements contained within an analyst's particular application that require monitoring. The Product Agent then maps these data elements into outgoing products or reports governed by certain specific conditions. Once a Product Agent has identified that sufficient data relevant to an analyst's product is available, it automatically generates the appropriate report.

### *Dissemination Agent*

This is a specialized COOP product agent that monitors the critical information requirements of other supported users and/or sites. The real power of cooperative analysis is realized when two or more sites are FALCON-equipped, thereby allowing automatic cooperation between the FALCON systems. Each FALCON system possesses a store of all other connected sites' data requirements. This is a useful function if these sites require similar research activities pertaining to trend or other modeling analyses.

### *Automatic Data Conversion Agents*

This is a group of agents that perform automatic data conversion from one data or message format to another. Each agent uses a pattern definition language to specify how a message or data set will be reformatted to ensure compatibility with other local FALCON processes. Such data conversions are often required between databases, communication protocols, and message formats.

### ***Indications and Warning Agent***

The indication and warning (I&W) functionality is provided to the analyst through the I&W Agent Editor. Using the I&W Agent Editor, the user may attach a conditional indicator to a message type, a database record, or a text string that may be contained in unformatted messages or documents. When the indicator is satisfied by data acquired by AIMS, the user-specified warning method is activated. A warning can be displayed as a flashing or highlighted icon on a FALCON workstation, or an automatically-generated alert message (e-mail) may be sent to another FALCON system or user. The I&W functionality also incorporates the revolutionary ability to perform historical indications and warnings. This is useful because analysts are alerted through warning processes about operational situations indicated by trends in the data, which are determined by monitoring past performances of these situations.

### ***Multi-Media Data Fusion Agents***

The unification of information available across the AIMS network into common formats is an important capability for the support of information fusion by the SAS. The two primary views generated by the SAS are a relational view of information, represented as link and node structures; and a physical view, represented as GIS displays. This set of agents provides FALCON with its analytical power and transforms data formats received through AIMS (e.g., logical expressions from a relational database) to an object-oriented format. This standard format enables the SAS to ingest the data easily into its object-oriented situational models for display through link graphs or GIS maps.

#### ***4.6.1.1.3 SAS***

SAS is the functional brain of FALCON, controlling and focusing the AIMS through its continuous requests for information sent via the COOP Agents. SAS acts as a mental extension to the analyst by providing a wide range of analytic tools (modeling capabilities) and services that operate under the analyst's control. SAS consists of five system software layers that act as servers to the analyst. They are:

- Situation Editor Tools that allow the analysts to define and view their own situational data objects, links, and patterns;
- An Object-Oriented Situation Database capable of handling structured and unstructured multi-media data that serves as the analyst's general situation data server;
- Situation Development Engine, a data-driven process that constructs and maintains the analyst-specified situation data objects and links;

- Object/Link Analysis Engine, a hypothetical reasoning process that can add hypothetical objects and links to the Situation Analysis Network;
- Situation Pattern Analysis Engine that incorporates many different technologies for use in identifying, representing, searching, matching, and discovering situational patterns.

Situation analysis agents work cooperatively to build, augment, and critique situational views of the threat. These agents are clustered by function and may implement any search or analytical technique that the user chooses to embed within them. Typical agent classes include evidence agents, which maintain current data on individuals, organizations, or objects declared to be of interest to an investigation; link agents, which search for named types of connection between data classes; pattern agents, which assemble links into clusters, evaluate them against known critical patterns, and given a sufficiently close match, drive the search for missing pieces; investigative agents, which are designed to spot anomalies between data and existing situational models and to drive agent-based investigations to resolve them.

FALCON is unique in that it exploits the cooperative agent approach for situation analysis. This is accomplished by building an architecture that combines proven information management and object-oriented programming techniques with advanced agent management and implementation. By design, all elements of FALCON work in direct support of the analyst's needs, thereby making the analyst the client and FALCON the server.



## 5.0 Results and Discussion

### 5.1 Jornada Experimental Range Legacy Data

The JER holding constitutes a unique record of the transition of a desert ecosystem from primarily a homogenous grassland to a heterogenous shrubland. Bio-physical data such as plant species basal diameter; species graphical representations; and rainfall, soil, and other vegetative aspects have been collected on the JER since 1915. These data provide an ideal foundation for characterizing habitat changes in semi-arid lands due primarily to the influences of large grazing animals and environmental changes. Although the complex processes involved in the transition from a grassland to a shrubland are poorly understood, the JER will support a detailed structural analysis of emergent landscape changes. Such an analysis is needed as a foundation for determining mechanisms and may actually be sufficient for predicting the effects of disturbances.

#### 5.1.1 Data Scanning

The JER legacy data set consists of approximately 7000 planimetered quadrat maps. The scope of the Phase I effort was to scan over 700 maps from 13 of these quadrats for the southwest portion of the JER.

When the scanning of the data was completed and verified, the images (714 quadrat maps, 734 backscans and addendum) were written to a CDROM. This was done in order to save the data to a stable format and to provide a quick method to access the data at a later date.

#### 5.1.2 Quadrat Annotation

The Quadrat Annotation phase required a longer time frame to perform than was originally anticipated. This is due to the fact that the student performing the annotation encountered undecipherable names, and names/codes which were not in the master botanical list. The student was permitted to update the codes, since this information is used only to reference the contours on the quadrats. Unlisted and undecipherable names were forwarded to a USDA botanist for referencing. They were then added to the master list. An estimated 50 entries were not in the original master list. In these instances, the annotation was left incomplete until the master list was updated; then, the annotation was completed.

#### 5.1.3 Indexing

In the Indexing phase, the following lists were generated: master botanical list, Latin list, and images list. Although these lists are specific to the JER flora, they could be used as a basis for other Chihuahuan Desert studies.

*ISEM Final Report, Volume I*

#### **5.1.4 Contour Vectorization**

In the contour vectorization phase, all of the scanned quadrat images were converted from raster format (image pixels) to vectors of the plant basal outline. The annotation lists were updated to account for code entries on the quadrats which were not annotated. This was not a difficult process, as the un-annotated codes were usually found elsewhere in the annotation list.

It would have been ideal for the quadrats to be image processed to remove the graph paper lines, noise, background colors, etc., such that vectorization could be automatically performed by the system. However, the variation in the paper used and the quality of the quadrat sheets prohibited the use of image processing algorithms to extract the contours.

#### **5.1.5 Data Archive**

Each of the scanned images, along with their associated annotation and contour vector files, were archived on the system hard drive, on tape, and on CDROM.

#### **5.1.6 Data Browser**

Not applicable.

#### **5.1.7 Quadrat Visualization**

Several assumptions were made when reconstructing graphical representations of the scanned quadrats. The USDA botanists provided a generalized ratio of plant height to basal area, since the only information obtainable from the quadrats is the planar view of the quadrat (plant width). Additionally, when plant seedlings were indicated on the quadrats, the field workers usually did not outline the plant contour, but placed a tick mark at that location. The outline of these plants was estimated.

The visualization of the quadrats is being done on both the Environmental Management Workstation (SGI) and the JDR workstation (PC). The visualizations provide a valuable tool to determine data capture problems. For instance, it can be determined in many cases whether the orientation of the quadrat was different from the normal north orientation by "seeing" perennial flora shift position between mapping years. In these cases, the vectors are run through a transform to re-orient them to a north-south orientation. Some mapping or annotation errors can be found and corrected if the user notices, for example, a mesquite bush changing into a forb, then reverting to a mesquite the following year. In these cases, the quadrats and annotations can be reviewed and the error located.

### 5.1.8 Data Set Verification

Data set verification was completed on the study area quadrat set, primarily by using the Environmental Management Workstation visuals. This method of verification provides an easy-to-use and reliable technique for discovering data errors.

### 5.1.9 Statistical Analysis

The correlation of the JER data sets will provide researchers with insight into the causes of environmental change. The statistical GUI is currently being used to isolate biotic trends and temporal changes on the JER. Additional work is required to incorporate additional data sets (e.g., rainfall and grazing) into the statistical GUI.

### 5.1.10 GIS Import

#### 5.1.10.1 *Quadrat Import*

Two AML programs were written to automatically generate graphic displays of the ARC/INFO® point, line, and polygon representations of the quadrat data. The first program, called *t\_map.aml*, creates an ARC/INFO® map composition and displays the results to a computer monitor. The second program, called *t\_quad.aml*, creates an ARC/INFO® map composition and sends the results to a greyscale postscript printer. The paper maps generated by this program are provided in Appendix K<sup>4</sup>.

#### 5.1.10.2 *Precipitation Data Import*

An AML program was written to automatically generate graphic displays of the ARC/INFO® interpolated precipitation data. The program is called *t\_eps\_c\_avg.aml*. It creates an ARC/INFO® map composition of the average precipitation values between 1965 and 1993 and sends the results to a greyscale postscript printer. The paper map generated by this program is shown in Appendix K<sup>5</sup>.

---

<sup>4</sup>These paper maps are labeled "A1 Quadrat Data June 1915", "A2 Quadrat Data August 1968", "A3 Quadrat Data July 1977", "A4 Quadrat Data August 1930", and "A5 Quadrat Data September 1949", respectively.

<sup>5</sup>This paper map is labeled "1965-1993 Average Yearly Total Precipitation Contours".

Output from Surfer<sup>®</sup>, EXCEL<sup>®</sup>, and EXECUSTAT<sup>®</sup> was created without the use of macros and is also provided in Appendix K<sup>6</sup>.

### **5.1.10.3 *Grazing Data Import***

An AML program was written to automatically generate 8.5" X 11" paper maps from the ARC/INFO<sup>®</sup> grazing coverages. The name of this program is t\_4paseps.aml. It creates an ARC/INFO<sup>®</sup> map composition and sends the results to a greyscale postscript printer. The paper map generated by this program is provided in Appendix K<sup>7</sup>.

### **5.1.10.4 *Digital Elevation Model Data***

A greyscale hardcopy image was produced from the DEMs. The image shows a shaded relief image of the Summerford Mountain topographic quadrangle with significant cultural features indicated. This image is provided in Appendix K.

## **5.1.11 *Image Processing***

### **5.1.11.1 *Land Use/Land Cover Maps***

#### **5.1.11.1.1 *Unsupervised Classification***

The land use/land cover map generated by the unsupervised classification method is provided in Appendix K<sup>8</sup>.

#### **5.1.11.1.2 *Supervised Classification***

The land use/land cover map generated by the supervised classification method is provided in Appendix K.

---

<sup>6</sup>These outputs are labeled "JER Avg Annual Precip (1965-1993)", "JER Annual Precip", and "3-Year Moving Average for Annual Precipitation--Jornada", respectively.

<sup>7</sup>This paper map is labeled "Grazing Intensity Annual Total, 1993".

<sup>8</sup>This map is labeled "Unsupervised Classification, 9 June 1993 SPOTVIEW Imagery".

### 5.1.11.2 Spectral Vegetation Indices

A 8.5" X 11" color hardcopy image was produced of the SAVI data set. This image is clipped to a subset of JER centered around pasture 9. The image is provided in Appendix K<sup>9</sup>.

### 5.1.11.3 Change Detection

The key technical objectives of the change detection efforts were precise image-to-image registration and convergence between the results of the two change detection protocols. With respect to the first objective, the mean Euclidean disparity measure achieved in the image-to-image registration was 92.06 meters, or slightly over 1 pixel.

For the second objective, accurate ground-truth data for the large areas covered by the Landsat MSS data was not available for this project and will be pursued in future work. In place of rigorous verification, similarities between the outcomes of different techniques was used to provide qualitative indications of the validity of the results. Good results were achieved, as the correlation coefficient between the results of the two change detection algorithms was - 0.87 ( $R^2 = 0.76$ ).

A 8.5" X 11" greyscale hardcopy image was produced from the Euclidean distance change detection algorithm. Areas shown represent "change" signals equal to or greater than three standard deviations from the mean "change" signal. Also included is a true-color composite of the Landsat MSS data set. The images are provided in Appendix K.

### 5.1.11.4 Image Data Merging

An 8.5" X 11" color hardcopy image of the SPOT panchromatic-Landsat TM merged data set was produced. This image is provided in Appendix K.

---

<sup>9</sup>This image is labeled "Soil-Adjusted Vegetation Index, 9 June 1993 SPOTVIEW Imagery".

*ISEM Final Report, Volume I*

## **5.2 Geographic Information System Backgrounds**

The background data layers incorporated into the ARC/INFO® GIS included: Pasture boundaries for the JER, rain gauge locations for the 34 standard rain gauges on the Jornada, well locations for the JER, digitized vegetation map based on a survey conducted by the USDA in the late 1920s, soils digitized from the Dona Ana County Soil Survey digitized by San Diego State University (SDSU), and elevation digitized from topographical sheets.

### 5.3 Simulation/Model Investigation

Due to the fragmented nature of rangeland modeling efforts, an inventory of models was determined to be difficult to assemble, as well as eventually unenlightening. As an alternative, a report was prepared on the application of Reynold's (Chen and Reynolds, 1994) Generic Plant Growth Simulator to rangeland modeling. Reynolds is the modeling head of the National Science Foundation (NSF) Long-Term Ecological Research program at the JER and has assembled both range-specific and generic components into the PALS model, which is a process model for plants and plant communities in arid lands.

#### 5.3.1 GEPSI

The modules comprising the GEPSI model are parameterized for specific species, related groups of species, life form classes, or broader groups. This parameterization depends upon how variable the process is across certain groupings and the level of variability that is acceptable for the question being investigated.

A photosynthesis model (GENLEAF) used in GEPSI has been validated under current CO<sub>2</sub> levels and responds realistically to short-term increases in CO<sub>2</sub>, although the function describing stomatal activity remains empirical. The GENLEAF module interacts closely with a specialized canopy module (CANDO), which is used to investigate components of within-canopy interactions important for predicting whole-plant photosynthetic response to elevated CO<sub>2</sub>. Preliminary results pertaining to the model interactions suggest that a more complex formulation of the light-interception calculations is necessary for predicting photosynthetic and transpirational response to elevated CO<sub>2</sub>. This more complex formulation necessitates the consideration of several separate classes of sunlit leaves (distinguished on the basis of azimuth with respect to the sun) instead of using average conditions of sunlit leaves within a layer. Thus, more precise calculations of gas exchange processes in leaves that are nearly light-saturated is possible because such leaves exhibit highly nonlinear responses to light and CO<sub>2</sub>.

A preliminary phenomenological allocation of nutrients module (ALLOC), which is used in GEPSI, has been developed which describes plant growth aspects as a function of reduced leaf N concentrations. This module is effective in predicting changes in root/shoot ratios, leaf photosynthetic capacity, and plant growth at varying levels of CO<sub>2</sub> concentration, light intensities, and N availability. This modeling activity is accomplished despite the lack of a complete mechanistic understanding of nutrient allocation. The prototype version of ALLOC used in GEPSI is effective at predicting root/shoot ratios, but is not designed to predict altered photosynthetic rates due to changes in leaf N concentration. This module is also effective in describing the allocation of N to photosynthetic enzymes in the leaf. This allocation module is particularly notable because it provides a system feedback loop between the whole-plant, canopy, and leaf level processes. Along with root and shoot biomass, the

*ISEM Final Report, Volume I*

photosynthetic characteristics are predicted for plants exposed to a wide range of environments.

On a larger ecosystem scale, the GEPSI model has been divided into two major aspects, the ENVIRONMENT and the PLANT. These aspects are used to develop modeling classes which describe the external influences affecting plant growth and development.

The ENVIRONMENT aspect contains driving forces which control plant growth and include an above-ground aerial environment and a below-ground soil environment. The above-ground aerial environment contains two classes--Weather and Microweather; the below-ground soil environment contains a single class--Soil.

The PLANT aspect is composed of many different classes which describe the physical makeup of a plant. These classes are the Plant, Stem, Leaf, Canopy, Rootsystem, and Root.

### 5.3.1.1 Environment

#### 5.3.1.1.1 Weather Class

By using theoretical and empirical formulas, the Weather class defines and specifies the weather conditions above the plant canopy which affect plant growth. These conditions include items such as Radiation, Ambient CO<sub>2</sub> Concentration, Wind Speed, Temperature, Precipitation, and Humidity objects.

The hourly short-wave radiation is calculated according to the solar constant, the sun zenith angle, and the attenuation coefficient of the atmosphere. The daily total short-wave radiation is based upon an integration of hourly values over the day length.

The Ambient CO<sub>2</sub> Concentration during day and night conditions are assumed to have two distinct constant values. These values are calculated based upon daily mean ambient CO<sub>2</sub> concentration and the ratio of day to night concentrations.

The daily highest and lowest air temperatures are generated based upon the daily mean air temperature and the amplitude of the daily temperature change.

The daily total precipitation is determined by assuming that both precipitation accumulation on sunny days is zero and precipitation on each rainy day is the same. These daily totals are obtained by dividing the total annual precipitation by the number of rainy days in the year. Rainfall prediction can be enhanced if the statistical distribution of yearly rainfall for a particular region is known.

The relative humidity for both day and night is assumed to have two distinct constant values. These constant values are calculated based upon the daily mean relative humidity and the ratio of daytime to nighttime relative humidity. To a great degree, the Weather class influences activity composed within the Microweather class.

#### **5.3.1.1.2 Microweather Class**

The Microweather class defines hourly micro-weather conditions within a canopy. The Microweather class is closely related to the Weather class because the hourly weather conditions above the canopy drive micro-weather conditions within the canopy. The Microweather class is related to the Canopy class primarily because the microweather conditions within the canopy are affected by the plant structure. The Microweather class provides hourly profiles of air CO<sub>2</sub> content, temperature, humidity, wind speed, and solar radiation aspects. It also defines the vertical profiles of micrometeorological variables within a plant canopy.

#### **5.3.1.1.3 Soil Class**

The Soil class defines a template for soil objects and provides physical and chemical conditions at each layer within a soil column. The Soil class defines the configuration of soil layering that is the common framework for heat transfer, water movement, and nutrient dynamics. A subclass called SoilHeatWater contains modules which integrate the one-dimensional partial differential equations for heat transfer and water movement within the soil. The soil column can be heterogeneous; that is, it can consist of a number of different soil types in the vertical direction.

#### **5.3.1.2 Plant**

##### **5.3.1.2.1 Plant Class**

The Plant class defines the template for generic plant objects and specifies the attributes and processes on the whole plant level. The physiological age of the plant and carbon allocation coefficients of the canopy and root system are also important attributes. The most important function of the Plant class is the carbon allocation between shoot and root.

##### **5.3.1.2.2 Stem Class**

The Stem class defines a template for generic stem objects and can be either a whole stem or a stem segment. When compared with leaves, stems are less functional in gas exchange, but since cellulose is the main product of some woody plants such as trees and shrubs, the growth of stems has to be described in detail. Green stems perform photosynthesis, but to a much

lesser degree than leaves. For simplicity, photosynthesis of stems are ignored in the Stem class and only maintenance respiration (assumed to be proportional to active biomass) is considered.

#### 5.3.1.2.3 Leaf Class

The Leaf class defines a template for generic leaf objects and describes how a leaf continuously exchanges gas and energy with the surrounding environment. Gas exchange ( $\text{CO}_2$  and water vapor) is the most important function of a leaf. The driving force is the difference in the  $\text{CO}_2$  concentration or the relative humidity in the open air and at the intercellular space. The gas exchange resistance encountered is the sum of the leaf boundary-layer resistance and the stomatal resistance. Fortunately, gas exchange processes of a leaf with its environment has been extensively studied using leaf chambers, and a number of mathematical models about photosynthesis, stomatal conductance, and leaf boundary-layer conductance have been developed. The parameters describing leaf growth such as area, length, and width are described in the Leaf class and updated on a daily basis.

#### 5.3.1.2.4 Canopy Class

The Canopy class defines a template for generic canopy objects. A canopy is divided into several horizontal layers; each layer contains a segment of the main growing stem originating from a single vegetative flush and a number of branches and leaves from each flush. The canopy is growing so that the number of layers and the number of main stem segments, branches, and leaves changes with time.

A canopy is divided into horizontal layers, and each layer corresponds to a flush of the main growing stem. The orientation of leaves is the most important factor for radiation interception, and it is specified by the leaf inclination distribution function. The total assimilation rate and transpiration rate of the canopy is the total contribution from each leaf in the canopy. The assimilation and transpiration rates of a leaf are calculated in the Leaf class using micro-environmental variables derived from the MicroWeather class and exported to the Canopy class. To increase the accuracy of the photosynthesis calculations, the sunlit leaves are divided into several groups according to the incident angles of the direct radiation to the leaf normal. This fraction changes with the sun zenith angle and leaf inclination angle.

The water potentials of all canopy components, main stems, branches, and leaves are assumed to be the same as the average water potential over the whole canopy and is updated several times an hour.

Canopy growth also includes the increase in its size and weight. The height of the canopy is determined by the height of the main stem, and the horizontal extent of the canopy is determined by the length of the branches described in the Stem class.

#### **5.3.1.2.5 Rootsystem Class**

The Rootsystem class defines a template for objects of generic root systems and specifies the attributes and processes at the whole root system level. Root system growth also includes the increase in size and weight and is divided into horizontal layers starting from the top. The depth of the root system is determined by the length of the main root (tap root), and the horizontal extent of the canopy is determined by the length of the active roots. The Rootsystem class updates on an hourly basis the uptake rates of water and nutrients of the root system and accumulates them into the daily total uptake rates.

#### **5.3.1.2.6 Root Class**

The Root class defines a template for a generic root object. The uptake of water and nutrients from the soil is the most important function of the roots. In the Root class, a single root is defined as a cylinder, which is consistent with most experimental and modeling studies performed in laboratories. The suberized roots are defined as inactive roots that do not uptake water and nutrients. Living roots are those roots which actively uptake water and nutrients and exhibit high respiration rates. It is assumed that only a small portion of the total biomass is live and conducts maintenance respiration.

### **5.3.2 MONOMOD/MIXMOD**

MONOMOD/MIXMOD decomposes the system (community) into its component parts, i.e., individual plants, populations of single species (MONOMOD), and populations of mixed species (MIXMOD) and describes the behavior of the system through the interaction of these parts. Assumptions are made that climatic change exerts a direct effect at the level of the plant and below, rather than directly at the level of the community or ecosystem. Changes in community structure and function result indirectly from the interaction of individual organisms. This model creates a theoretical framework of the problem of plant community structure and function with respect to variable CO<sub>2</sub> and climate change.

### **5.3.3 SERECO**

The SERECO ecosystem model has been designed to incorporate models of plant responses to climatic influence into a generic ecosystem model in order to predict the direct and indirect effects that climate change has on ecosystems. Preliminary results have been obtained pertaining to the response of four different ecosystems--tall grass prairie, aridlands (desert shrubland), loblolly pine forest, and arctic tundra--to changes in the abiotic environment. In each case, changes in various elements of the GEPSI/SERECO models are incorporated to adapt them to the specific ecosystem. Each of these ecosystems utilize the various modules of SERECO differently and in varying degrees of complexity.

*ISEM Final Report, Volume 1*

The PALS model has been used to examine the response of the JER semi-arid ecosystem to variability in rainfall. PALS showed that total annual primary production was quite variable from year to year under ambient climatic conditions--more than twice as variable as rainfall. However, this variability was associated primarily with production of herbaceous annual species. Production of shrubs was relatively constant from year to year. Simulated changes in rainfall variability revealed that there was a magnification in variation of vegetation production compared to variation in rainfall. This was observed to be the result of variation in production of herbaceous species. Changing the frequency of rainfall types was observed to have a direct effect on herbaceous annual species by impacting a specific group of annuals specialized in the utilization of a particular pattern of rainfall, such as summer annuals that use monsoonal rainfall. Shrub production was not observed to change over the length of the simulation. PALS simulations are not only consistent with the finding of high variability of production in desert ecosystems, but offer an explanation for this variability.

#### **5.4 Ontology of Habitat Classifications of Jornada Data**

The classification of the vegetation in the study area using the metrics of kriging and co-kriging is currently in progress. It is maintained that this methodology will provide a more efficient classification than other, more traditional measures such as field mapping, NDVI, SAVI, GVI, etc. Work will continue along these lines using the data sets obtained from the current study. It is expected that the kriging will produce an accurate vegetation map and that the method employed will provide insight into other ontological work in arid regions.

*ISEM Final Report, Volume I*

## **5.5 Conceptual Framework for Arid-Land Characterization**

### **5.5.1 Field Mapping System**

The project participants generally found great utility in the field mapping system. Automated digital data collection was achieved through the use of this system. There were, however, some weaknesses in the prototype system, such as the laptop operation's inability to perform adequately in direct sunlight. Consequently, it was necessary to cover the screen to provide complete shade.

Landscape shots were successful for general orientation and a view of the surrounding topography. Sub-meter GPS positions were obtained for each of the near nadir camera shots. The images were successfully processed using the image processing software into vegetation clusters. The bitmap images could not be converted into a GIS format. Conversion to a GIS would facilitate data extrapolation of the quadrat data to an array.

### **5.5.2 Interpolation/Extrapolation Approaches**

#### ***5.5.2.1 Proposed Self-Learning Approach to Modeling***

In order to manage desert rangeland, it is necessary to identify component ecosystems that are either undergoing change (unstable), or that have the potential for sudden change (metastable). More particularly, it is important to identify those areas where transitions are adverse to primary production, and which are not readily reversible. As discussed above, ecotones may be defined over a hierarchy of spatial scales extending from the plant level (approximately 1 square meter) to the biome level (approximately 10 km square), where each scale is associated with a set of characteristic constraints. The sample encoding is intended to be used for the prediction of ecological change over an idealized gridded landscape through inductive, spatial interpolation and extrapolation between sampled data points.

The JER is situated at the northern end of the Chihuahuan Desert. Because conditions are marginal for many species, the area's grassland ecology (primarily Black Grama) has been replaced, under stress, by a shrubland ecology (primarily Mesquite and Creosote Bush) over this period. This change in the ecology is due to the effects of overgrazing and drought. The idealized gridded landscape will be based on landscape scale (1.0 - 2.5 km square) quadrats comprised of cells empirically determined to acceptable samples for patch scale units for the area viz (0.5 - 1.9 km square). Figure 19 illustrates such a landscape.

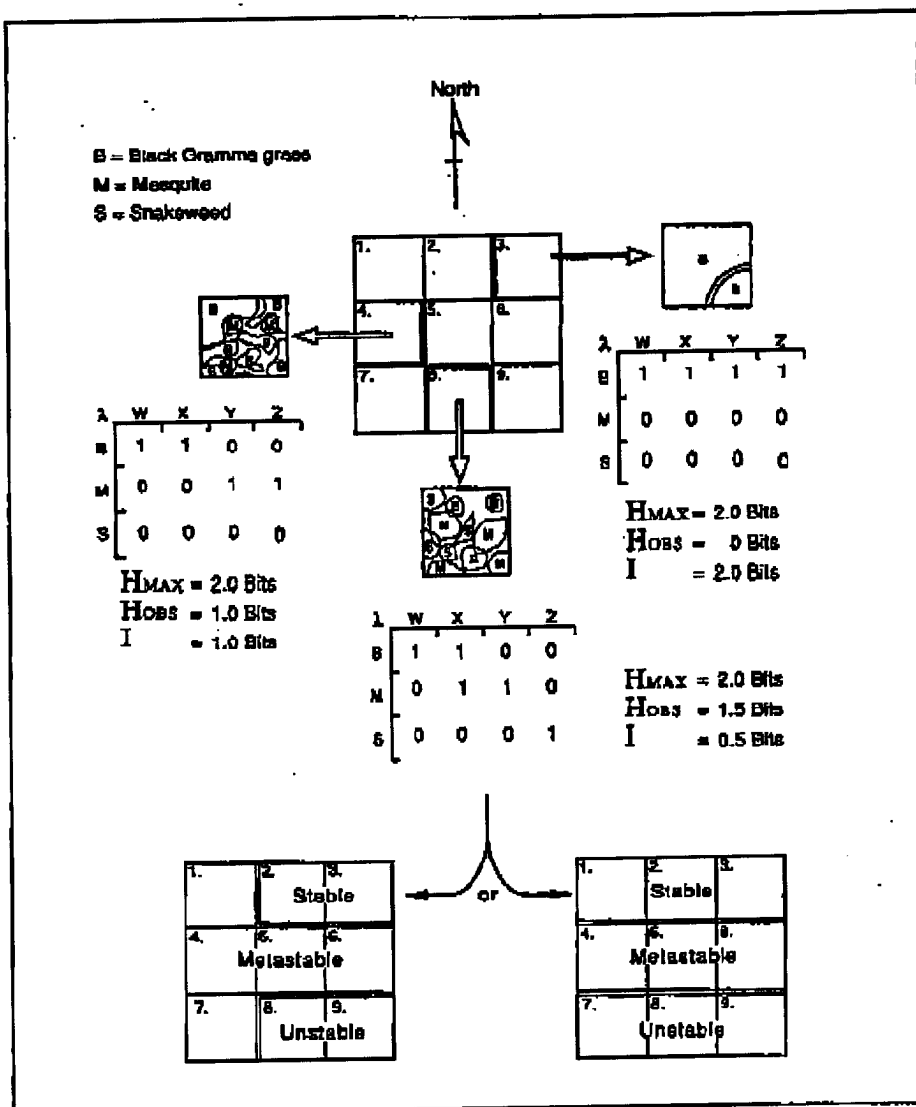

Figure 19. Example: Landscape Encoding

Figure 19 represents an idealized landscape scale quadrat for the Jornada as a 3 X 3 grid. The quadrat was assumed to support three species: Black Grama (B), a grass; Mesquite (M), a shrub; and Snakeweed (S), a forb. It was also assumed that the Mesquite is invading the Black Grama grass. In the study, the key ecological relationships will be encoded as binary relationships between subsets of entities. Entity subsets are represented by an alphabet which includes species terms (B, M, S), and ecological niche terms (w, x, y, z) connected by the relation "occupies". Niches are defined in terms of resource richness, and are ordered from w to z. In the example, data is available for three cells. Cell three represents a stable population of homogeneously distributed Black Grama. Cell four represents a metastable region, with heterogeneously distributed Mesquite and Black Grama. Cell eight represents an unstable region of small, heterogeneously distributed, often intersecting, clumps of Black Grama, Mesquite, and Snakeweed. The aggregate dynamics of a cell may be identified from the distribution of species (taken as macrostructure for the example, which was developed to explore the integration of abiotic variables) over niches (taken as system microstructure), which provide information-theoretic measures of order and disorder, i.e., to indicate the encoded systems relative state of energy driving the system to self-organization and competition. Several such information-theoretic metrics have been suggested in the biological literature. As an illustration, entropy values calculated for the data cells have been derived using a simple application of the hierarchical information theory methods described by Brooks and Wiley (1988).

In Figure 19, Hmax represents the total realizable entropy for the cell; Hobs represents the observed entropy for the cell, and as a result, the degree of disorder; I, calculated as  $H_{max} - H_{obs}$ , provides a measure of order. Thus, considering the simplicity of the example, cell three is in an ordered state, cell eight is in a relatively disordered state, and cell four is balanced between order and disorder. In a simplification of Brooks and Wiley (1988), cell three is classified as stable, cell eight is classified as unstable, and cell four is classified as metastable. Finally, at the base of the figure, there are two hypothetical interpolations from the order and disorder values for the three data cells. The results allow for:

- identifying the state of self-organization for each cell;
- projecting an arrow of time over the landscape (upwards, with the metastable Mesquite/Snakeweed region invading the Black Grama region);
- identifying the ecotone (the unstable region); and
- identifying the energy (ascendancy) of each region from the component order/disorder metrics (not shown).

Finally, information on the state of a cell may be obtained from an analysis of the multi-dimensional connectivities within it. Using the matroid analysis methodology discussed by

Srikant and Coombs (1993), structural indices may be extracted from the binary relationships between species and niches that it represents. For example, Mesquite and Black Grama compete in cell eight for occupancy of the cell, while the niches are partitioned between the two species in cell four. Such partitioning is indicative of metastability, where fragile stability is maintained by the temporary partitioning of niches along some abiotic gradient. A very rich language is available from simplicial topology for describing significant connective patterns, which can be applied to understanding stability issues in evolving communities (Atkin, 1972, 1974, 1976; Casti, 1980).

Coombs and Srikant (1994) have proposed a self-learning, grid-based modeling methodology that supports the exploration of the topological properties of evolving tropic networks (food chains). This methodology provides a "holistic" representation that incorporates both spatial heterogeneity and temporal correlations. It also displays the structural properties of energy grids. Energy grids relate closely to the notions of trophic networks and the flows of energy between species that they represent. Further information on this approach may be obtained from the authors of this report (see U.S. Army Corps of Engineers' proposal "An Environmental Workstation based on a Self-Learning Competitive Combinatorial System and Simple Process Models").

The proposal argues after Haynes (Haynes et al., 1973, 1975) that it is not possible to create "absolute" indicators of habitat productivity because of the adaptability and nondeterminism of biological systems. The alternative is to iteratively create and refine indicators and controls based on observable changes in a monitored biological system. The value of models in management changes from providing a single long-term prediction of ecosystem change to providing a spanning set of possible near-term ecosystem trajectories to use continuous control of the managed ecosystem.

From this perspective, a workstation is being proposed that:

- (i) characterizes ecosystems from incomplete data through interpolation based on induced competitive interactions, and
- (ii) constructs tools for the management of ecosystems based on advanced, unconventional, and nonintrusive data sources (e.g., photographic and remotely sensed data).

The proposal includes using a self-learning gridded landscape that learns to synthesize sets of global hypotheses concerning the evolution of habitat connectivity and interactivity from past and current ground and satellite data. Learning criteria will include applicability to management objectives and scale and sensitivity to possible ecosystem dynamics (e.g., it may be expected that spanning sets of hypotheses needed for monitoring metastable systems will be

*ISEM Final Report, Volume I*

different from those needed for stable systems). Typical data will be extracted from the 80-year record from the JER, and will include information on diversity, community structure, niche structure, dispersal channels, and abiotic resources. In the context of a workstation, the self-learning landscape will cycle through the stages of:

- initial calibration through learning possible trajectories in historical data indicating some relevant pattern of habitat change;
- trajectory projection;
- periodic adjustment triggered by anomalous field data; and
- recalibration given a sequence of poor predictions.

### **5.5.2.2 The Landscape Prediction Problem**

#### **5.5.2.2.1 Deterministic Patterning**

Ecology is critically concerned with the geographic and spatial distribution of organisms. However, the "unit of study" for ecology has changed over time, along with changing assumptions about the principal dynamics of ecosystems. In general, classical models are strongly deterministic. The chief influence was Clements (1936) with the theory of successional dynamics, where biomes were assumed to move through a sequence of stages towards a stable endpoint--the "climax" state--under the influence of regional macroclimate. The order of succession was further assumed to be relatively uniform across regions with similar microclimates, and the transitions between successive stages were assumed to be relatively smooth.

The importance of spatial patterning under succession was emphasized later by Gleason (1939) and Whittaker (1975). Gleason interpreted such patterning as resulting from individualistic biotic responses to physical gradients in the environment. Thus, simple succession was now seen to be moderated by local abiotic gradients, spatial patterns in climax biota reflecting intersections of species responding to complex abiotic gradients. This introduces the idea of biotic variant at a scale. More recently, there has been another, more dramatic shift in emphasis. While there has been a long history of research into the processes causing patterns in the landscape, the effects of spatial patterns on ecological processes have been largely ignored (Turner, 1989). Although there has been extensive research conducted into the effects of landscape-level constraints on biotic interactions, and the development of spatial heterogeneity (Troll, 1939), this orientation has been given new impetus from modern work on nonlinear dynamics.

Watt (1947) argued that patterns across a landscape resulted from asynchronous distributions of the temporal sequence of successional stages. The persistence of spatial patterns--the landscape "mosaic"--was seen as the product of the orderly sequence of phases at each point in space. Thus, a constant changing spatial pattern was maintained by temporal changes at each point.

#### 5.5.2.2 Stochastic Nonlinear Dynamics

With increasing sophistication in the understanding of dynamics, ecosystems have come to be viewed as examples of complex "open" systems. Open systems are those that are kept in a state of dynamic nonequilibrium through the constant exchange of information and energy with their environment across a system boundary (Nicolis and Prigogin, 1989). While open systems theory was originally developed to describe physical thermodynamic processes, it has come to be applied in a specialized form to biological systems. Organisms are described as "informed" kinetic structures, in which the information coded in such static structural elements as DNA provide organized pathways for degrading matter and energy (under autocatalysis<sup>10</sup>). "The information encoded in the genomes of living things (is seen as) focusing thermodynamic flows into autocatalytic organizations" (Wicken, 1987). Autocatalysis should be simply viewed as an adaptive mechanism which permits hierarchies of constraints to emerge within a system, i.e., the system self-organizes so that it can maintain cohesion and stability under external influences.

Ecosystems consist of collections of organism which, through interactions with other biotic and abiotic entities, display a remarkable duality. On one hand, they are cohesive, self-regulating, and stable; on the other, they adapt to change and using feedback to control adaptation. Existing in a state of dynamic equilibrium, the ecosystems constantly maintain the possibility of change. In complex systems research, the notion of "possibility" is captured by the concept of entropy. Entropy is broadly defined as a quantitative measure of the amount of initial structure (degrees of freedom) available to the system, and is reflected in the properties of randomness and asymmetry. Randomness arises out of the inherent unpredictability (uncertainty) of system trajectories unfolding in time, giving rise to measures of system states based on the distribution of possible trajectories (macrostates) over the initial degrees of freedom available to the system (microstates). Asymmetry is expressed in terms of irreversible bifurcations<sup>11</sup> in trajectories. Bifurcations thus constitute a selection that

---

<sup>10</sup>An autocatalytic system is a system with an internal organization of kinetic relationships able to be maintained by pulling environmental resources into production.

<sup>11</sup>Bifurcations are defined as sudden and dramatic changes in system behavior resulting from small changes in the control parameters of a nonlinear system.

reflects certain structural constraints and obstructions in system development (in time and/or space) (Kapur and Kesavan, 1992).

Given a complex, open system perspective, ecosystem dynamics should be expected to display both stochastic and asymmetric behavior. The regular, uniform succession of biota towards a stable climax state, which was first proposed by ecologists in the 1930s, would be a most unexpected property. In addition, the adaptive (autocatalytic) nature of the organisms that make up ecosystems would promote the expectation that behavior would be highly subject to scaling effects that emerge under varying degrees of external challenge. Such properties are observed at the landscape level.

#### *5.5.2.2.3 Scaling Effects and Prediction*

As indicated above, landscape ecology studies changing distributions of species over broad spatial scales, and the ecological effects of the spatial patterning on ecosystem development. More specifically, it considers:

- the development and dynamics of spatial heterogeneity (of species, habitats, ecosystems);
- interactions and exchanges across heterogeneous landscapes; and
- the influences of spatial heterogeneity on biotic and abiotic processes.

Given the status of ecosystems as dynamic nonequilibrium systems, an understanding of the temporal dimension is basic to understanding system interactions, stability, and change (Kauffman, 1989).

Studies by Gosz (1993) in a related semi-arid land area of New Mexico indicate strong effects of scale. Ecological change is associated with transitions between different ecosystems, termed ecotones. Ecotones may be observed on the ground as intersections between areas having a common biotic distribution, where particular connectivities between biotic clusters indicate the action of different sets of constraints operating on and between different scales. Thus, ecotones may be defined over a hierarchy of spatial scales that extend up five levels, where each level is associated with a set of primary constraints and constraints are aggregated at higher levels. The proposed levels are:

- Plant ecotones;
- Population ecotones, i.e., plant patterns;
- Patch ecotones, i.e., defined over a set of dominant species;

- Landscape ecotones, i.e., mosaic pattern of patches; and
- Biome climactic ecotones.

Constraints vary from climate and topography at the biome level, to at least eight factors at the lowest, plant level, e.g., interspecies interactions, intraspecies interactions, physiological controls, plant genetics, microclimatology, soil chemistry, soil fauna, and soil microflora.

Gosz (1993) also supports the contention that ecosystems should be regarded as complex systems: "... spatial patterns in landscapes have abnormal, spatially autocorrelated, nonstationary, discontinuous, and irregularly spaced parameters. The dynamics of ecotones in landscapes also are likely to be nonlinear, perhaps chaotic, and can behave in ways that are not simply averages of adjacent resource patches...". Moreover, since the threshold dynamics of ecotones may be expected to be metastable (in a dynamic nonequilibrium), the prediction of landscape change presents a significant challenge.

#### *5.5.2.2.4 Qualities of Ecosystem Dynamics*

##### *Characteristic Properties of Landscape Change*

The studies reported by Turner (1989) indicate that ecosystems manifest the properties of open, complex systems. Moreover, these properties are exhibited most dramatically in arid and semi-arid regions, and may be observed locally in the area being studied under the current project. From the JER data, and related data collected on this under the NSF Long-Term Ecological Research (Schlesinger et al., 1990) program, there is substantial evidence for catastrophic dynamics in the ecosystem, including the characteristics of:

- modality (distinct conditions or states of existence);
- inaccessibility (conditions that are very unstable);
- sudden change (relatively rapid movement between states);
- hysteresis <sup>12</sup>(processes involved with degradation or recovery are not readily reversed by simply inverting the sequence of events); and

---

<sup>12</sup>Hysteresis is a manifestation of bifurcation.

- divergence<sup>13</sup> (relatively small changes in initial conditions can result in dramatically different outcomes with time) (Lockwood and Lockwood, 1993).

Similar dynamics have been observed in Australian rangeland (Laycock, 1991; Friedel, 1991; Westby et al., 1989).

Thus, the conventional approaches to the analysis of landscape dynamics are based on process modeling using the various forms of differential equation. This method has proved to be effective for the analysis of phenomenon which:

- apply to a single scale;
- involve a relatively small number of dominant variables;
- possess dynamics that may be characterized by linear, or nearly linear, systems of equations; and
- are largely deterministic.

It is proposed in the above that landscape ecology fails on all these assumptions. Prediction of landscape change requires sensitivity scale-dependent effects, involving systems that are very complex, and which may change their nature dramatically at any level in response to the changing biotic and abiotic context of surrounding levels.

### *Information-Theoretic Indicators*

An alternative approach exists which also corresponds well with the landscape management philosophy advocated in this proposal. It is possible to induce the nature of the dynamics underlying a system through the observation of behavior. For example, systems near bifurcation points will display increases in the relaxation time from small perturbations, and increases in the variance of observed fluctuations (O'Neill et al., 1988). It should be possible for an observer to learn to track the dynamics of an evolving ecosystem through studying its information structure. Entropic measures of order and disorder applicable to the assessment of ecosystem information structure have also been proposed by Brooks and Wiley (1988). Proposed in the context of a program to develop a unifying theory of biology using "hierarchical information theory", i.e., measures of the organization of biotic systems with

---

<sup>13</sup>Divergence is a manifestation of randomization.

successive layers of micro- and macro-structure to determine indications of a system's degree of self-organization (stability)<sup>14</sup>.

### *Connectivity Indicators*

Underlying these various measures is the notion that changes in connectivity that occur as links are added to a system may be a driver behind many kinds of emergent behavior in ecology, i.e., it is the connectivity itself that provides the focus for thermodynamic flows. Moreover, given the abstraction that ecological organization arises from only two sources--constraints from without and interactions from within the system (Green, 1993)--it should be possible to capture many indices of the dynamic state of an ecosystem from representations of relations between biochemical gradients and organisms. Focusing on vegetation, the gradients would be defined over abiotic features that govern the availability of resources, and the organisms would be sets of plant species viewed as (potentially) interacting packets of processes.

Speculations regarding the effects of connectivity on ecosystem processes concern the formation of clumped distributions. Clumped distributions tend to resist invasion better due to the generation of super-abundant seed pools, and the creation of supportive microenvironments (e.g., through litter build-up and improved water infiltration inside the clump). However, it is proposed from a complex systems perspective by Green (1993) that poorly-connected ecosystems, involving interactions between only a small number of species, tend to be stable, i.e., if some interactions are wildly unstable, only a small number of species will be lost to the system. However, richly-connected ecosystems will tend to be unstable at a local level, although the ecosystems may have evolved to be stable at a globally level. Indeed, their very global stability may well require local instability to maintain their capacity to adapt to changing abiotic environments. For example, forest insect populations may become locally extinct after outbreaks and, after the forest has recovered, the insect reinvades from areas of higher density.

### *Other Modeling Efforts*

Work in complex systems (Langton, 1990, 1992; Kauffman, 1992) and ecology (Levins, 1977) has demonstrated the value of qualitative modeling when dealing with large, highly

---

<sup>14</sup>Brooks and Wiley (1988) propose that: (i) ordered systems display high order over disorder at high and low dimensions of connectivity, (ii) disordered systems display high disorder over order at low and high dimensions of connectivity, and (iii) self-organizing systems in the process of changing display high order over disorder at high dimensions of connectivity and high disorder over order at low dimensions of connectivity.

connected systems. With metastable systems, it will be virtually impossible for numerical modelers to determine values for all relevant parameters with any certainty. Given the sensitivity of such systems to small differences in parameters, predictions would be of little value. Therefore, the percolation methods of Gardner (1987) and the trophic flow networks of Ulanowicz (1989) can be viewed as good tools for evaluating predictions of landscape change, but not for making those changes.

#### ***5.5.2.2.5 Model: Prediction Change by Evolving Trajectories***

This report proposes an alternative approach based on machine learning and complex system thinking, and also a method for the learning and prediction of landscape trajectories by emulating open system landscape dynamics over the inherently closed system of a computer program. The work will demonstrate how a combinatorial representation can be developed that incorporates the properties of biotic and abiotic spatial heterogeneity and temporal correlations, and that also displays both the structural properties of biotic and abiotic "fitness landscapes" and the dynamical properties of a stabilizing system. The research will address the encapsulation of the two concepts of structure and interactions into an effectively computable "holistic" representation scheme and the exploration of the slow thermodynamic (informational) evolution of such representations through a statistical-mechanical, self-organizing procedure. The goal will be to delimit the long-range competitive behavior of a family of open system agents (species) by treating their interactions as a source of disturbance,

### **5.5.3 Geographic Information System Products**

The GIS products derived from this effort include comprehensive coverage of spatial and temporal relationships of the quadrats in the study area, updated vegetation maps, stocking rates, surface precipitation, and boundary locations. Preliminary efforts of supervised/unsupervised classification of satellite imagery and data set correlations have been performed. The Environmental Management Workstation is the data repository and center for this information store. These GIS data layers are currently being used by researchers to investigate process-level phenomenon at the Jornada Experimental Range.

### **5.5.4 Applicability Study of FALCON Workstation**

#### ***5.5.4.1 Integrated Environmental Management System***

Successful land management requires an understanding of both physical and biological processes. This understanding has to cross both space and time scales and include the retrievable history of a resource, its present state, and its degree of change. Past and present data must be used to predict resource reactions to changing natural conditions and different land management practices.

Recently, issues pertaining to the conservation of natural resources has become critical to the DoD mission. A new understanding that DoD lands comprise only a fraction of larger ecosystems compounds the problem. The DoD faces new challenges in efficiently maintaining biological diversity within its fence lines to comply with an increasing degree of regulation. The problem is particularly acute in the arid and semi-arid Southwest, where resource quality and quantity restrictions threaten to slow and even preclude the training potential of DoD lands. However, the ability to tailor land-use to restoration, threatened and endangered species requirements, and biological diversity requirements, should allow resource managers to invest conservation and pollution prevention funds more effectively.

Currently, many regulatory decisions are made utilizing worst-case scenarios which compensate for the lack of true land resource management information. A quicker, more complete, and less expensive method for collecting and analyzing field data will yield higher quality data and will allow managers to make more informed management decisions. Better management decisions will allow for greater land resource use without corresponding degeneration. Managers, regulators, and resource agencies will all benefit from quicker, more reliable environmental assessments and audits made possible by this proposed system. Given a systems representation of habitat-specific ecosystem factors and relationships grounded in real data, the manager should be able to identify relevant variables and interactions operating at different space and time scales. The manager should also be able to envision possible alternate futures through projection of these interactions, and to explore methods for moving toward a desired future state.

The development of an Integrated Environmental Management System (IEMS) entails the creation and integration of the following major capabilities:

- Develop a high quality background environmental database;
- Create the tools necessary for the data fusion of numerical and graphical image information;
- Develop the capability for remote communications access to environmental databases;
- Develop and provide access to environmental models which perform future projections;
- Develop a hardware/software system utilizing GIS, GPS, and portable computers.

The above list of functions mirrors those provided by FALCON, since FALCON was designed as a generic information fusion workstation with a view to commercial application to other decision domains.

#### ***5.5.4.1.1 Background Environmental Database***

The success of an IEMS is partially dependent upon the integrity of the background data used to perform long-term predictions. This data must be easily accessible, be of high quality, and exhibit sufficient trending capabilities. To ensure the success of the IEMS, vast amounts of environmental trending data describing the JER have been gathered, analyzed, and archived since 1915. These data sets describe in detail the desertification processes that have taken place on the JER for decades. A recent survey of environmental modelers and end users revealed that major concerns related to data archiving, data management, data collection standards, and knowledge of existing databases were of top priority (Pijanowski, et al., 1992). As described earlier, efforts have been successful in converting this data into electronic format and incorporating it into a managed database, thus making it accessible for use in modeling purposes.

The evaluation of data quality has become a major issue for network data suppliers under the NSDI. The evaluation of quality is a very complex problem, involving the degree of nonlinearity in the problem being investigated, the adequacy of the sampling methodology applied, the assumptions behind the analytical tools to be employed, and the quality of actual data collection. These complexities, and an understanding of the limitations that are imposed on situational evaluations and projections, are unlikely to be appreciated by many users. This problem may be addressed under the FALCON design by incorporating the appropriate data evaluation and filtering routines into the system's data access agents. Using existing client/server technology, it would be possible for "warning" agents at the client level to be invoked by the headings of server data files, and "special requirement" agents in data servers to be invoked by client analysis agents. Information may also be made available regarding methods for merging with local data, or of data conditioning using field data.

Past data gathering efforts have ensured that the JER trend data is of high quality pertaining to accuracy and completeness and that it will provide a realistic reference for future modeling comparisons. Presently, the knowledge of existing databases possessing similar trending information is of lesser concern to this project because of the initial limited scope, but will be addressed during the expansion phase.

#### ***5.5.4.1.2 Data Fusion***

Data fusion is defined as the joining of numerical and graphical data into an electronic database. Numerical data could include some biological elements, such as plant species composition and frequency, plant height, plant crown dimensions, plant spacing, soil type and

nutrient/moisture content, and wildlife/domestic animal populations. Also included in the numerical data category are climatological information such as wind velocities, sunlight intensities, evaporation and transpiration rates, and rainfall totals. Graphical information would include such items as photographs, sketches, CCD camera images, topological maps, aerial photographs, and satellite images.

By converting numerical and graphical data into electronic format for incorporation into an integrated database, the fusion of these data can be accomplished relatively easily. The fused database can then be made readily accessible for import into a GIS for subsequent use in user-defined modeling processes. It can also be used in the production of reports.

#### ***5.5.4.1.3 Remote Communications Access***

The ability to remotely communicate with database clearinghouses and computing resource centers around the world is imperative in order to empower the environmental landscape manager with the tools necessary to analyze existing conditions and create long-term trending predictions. With the advent of the cellular telephone and the Iridium satellite telephone communications network slated to be operational before the end of the decade, it will be possible for environmental assessment to occur anywhere on the face of the earth.

Using standardized communications protocols and remote communications capabilities frees the landscape manager from the obstacles associated with the storage of large amounts of environmental information. Freeing the landscape manager from these obstacles allows for the design of a small, compact, and portable system. Remote communications capabilities also provide the ability to perform high-speed data searches and multi-processing activities. Utilizing more powerful computers located at discrete locations tasked to perform environmental trending analysis, the resource manager can then create multiple trending scenarios using the portable system as a remote terminal.

#### ***5.5.4.1.4 Environmental Modeling Capability***

The ability to correctly and efficiently model environmental trends pertaining to specific locations is the most important aspect of an IEMS. A recent publication written by the Federal Coordinating Council on Science, Engineering, and Technology's (FCCSET) Committee on Earth and Environmental Sciences (CEES) (1992) recommends that models developed for global change research have the ability to:

- forecast long-term trends, such as 50 or more years;
- integrate many processes, including atmospheric, biological, chemical, physical, and social elements;

- be based upon a set of scenarios and assumptions; and
- be incorporated into a GIS.

Even though these recommendations were developed for global change research, they would apply to environmental assessment research being conducted on more localized scales. In addition to these recommendations, several others are suggested. The models should:

- be readily available;
- use a common operating system environment;
- possess capabilities for high data resolution;
- be written in a common programming language;
- allow the user to incorporate customized software changes; and
- allow for importing of remote sensed data.

The FALCON architecture would provide an opportunity for the workstation to become a node on a Distributed Interactive Simulation (DIS) network. The DIS protocols would be handled by special DIS simulation agents, which would link with the appropriate data and reporting agents.

#### ***5.5.4.1.5 Hardware/Software System***

The integration of both hardware and software features must be appraised when a complete IEMS prototype is being considered. Hardware features include the computer platform, GPS receiver, and remote communications system. The computer platform must be portable and ruggedized for extreme operating environments. It must possess the ability to perform high-speed processing and interchange, have sufficient memory for processing and storage, and have sufficient communication ports, allowing access to digital communication devices such as CCD cameras and modems. The GPS receiver hardware must also be ruggedized for extreme operating environments. It must possess the ability to communicate with a computer and provide potential resolution to 1 cm. The remote communications hardware must allow the user to communicate from anywhere in the world with database clearinghouses and computer centers using Internet or other network protocols.

Software features include the computer operating system, communication protocols, an interactive routine which performs modeling and futures scenario creation, and modeling results and report generation. The computer operating system should be a common

environment such as DOS, Unix, or Windows. Many environmental and vegetation production models operate under these environments; their use would therefore minimize the production of a "turn-key" IEMS. Many environmental models and databases, satellite image databases, GIS capabilities, and specific agencies are linked together using the Internet. Providing this communication capability would be an advantage. The main purpose of an IEMS is to create modeling scenarios based upon futures predictions. By performing the modeling processes on the remote computer, the landscape manager possesses the ability to interact with the models and "fine-tune" the predictions. If the modeling effort is too extensive, providing remote access to computing facilities through Internet would allow the landscape manager to optimize the modeling convergence process. Table 2 describes one possible method for integrating a FALCON open system architecture with an IEMS.

**Table 2. IEMS Requirement Description/Corresponding FALCON Features**

Requirement Category	IEMS Requirement	FALCON Features <sup>1</sup>
<b>Background Environmental Database</b>	Data Archiving	1,8
	Data Management	1,2,4,6,8,9
	Data Collection Standards	1
	Knowledge (Accessing) Existing Databases	1,2
<b>Data Fusion (Numerical and Graphical Data)</b>	Incorporate Numerical and Graphical Data into Database	2,8
	Import Fused Data into GIS	8
	Produce Reports	1,4,8
<b>Remote Communications Access</b>	Telephone/Modem Links	3,7
	Standardized Communications Protocols	1,3,6
<b>Environmental Modeling Capability</b>	Long-Term Forecasting	7,9
	Integrate Processes	3,2,6,9
	Scenario/Futures Creation Capability	5,7,9
	GIS Incorporation Ability	5,6
<b>Hardware/Software System</b>	Communications Ports	3
	Database Access Using Internet and Other Protocols	1,3,6
	Interactive Capability	7,9
	Remote Access	5,7
	High-Speed Processing and Interchange	1,7,9
	Data Display	2,7

FALCON Features:

- 1 AIMS
- 2 Analyst Input COOP Agent
- 3 Intelligent Query COOP Agent
- 4 Product/Reporting COOP Agent
- 5 Dissemination COOP Agent
- 6 Automatic Data Conversion COOP Agent
- 7 Indication/Warning COOP Agent
- 8 Multi-media Data Fusion COOP Agent
- 9 Situation Analysis System

## 6.0 Summary and Conclusions

As stated in Section 3.0, the objectives of Phase I of the Information Support for Environmental Management project are to:

1. Establish a sample data set of high quality data derived from the JER holdings for use in the development of semi-arid land ecological situation analysis and management methodologies;
2. Identify existing and potential analytical frameworks (models) for characterizing habitats in time and space;
3. Prototype a basic set of GIS-oriented data fusion approaches for habitat management; and
4. Review the applicability of the autonomous agent (i.e., FALCON workstation) approach to support the GIS-based data fusion tools.

### 6.1 Legacy Data Capture

The need to preserve legacy data such as that available from the JER is very important in studying both local and global environmental change and for environmental assessment. The methods and systems developed and evaluated in Phase I are pertinent to other sets of data-at-risk on the JER and elsewhere. The use of properly-designed GUIs with intelligent error checking and correction is essential for the development of accurate capture methodologies for at-risk legacy data sets. The integration of these interfaces with data visualization techniques provided for the acquisition of extremely clean and accurate data sets. The initial costs involved in the development of a data capture system (partially funded by CIESIN) are easily offset by the speed and consistency of the data rescue. Similar methodologies may be adopted in situations involving the preservation of large sets of hardcopy or softcopy data.

### 6.2 Analytic Frameworks for Habitat Characterization

Habitat characterization requires a recognition of the dynamics of the physical and biological environment. Such dynamics involve interactions between many complex processes across many scales. While many of the processes are well-studied and understood locally, the interactions between them, and the relative importance of these processes on the landscape scale, are not.

Ecological modeling has traditionally been process-oriented rather than phenomenological. Using systems of differential or difference equations, modeling at the ecological scale is achieved by the hierarchical aggregation of models concerning the processes of plant growth and propagation into super-models. However, there is evidence that even with well-defined process and interactions, the approach would be weak due to: (i) computational complexity; ii) excessive input data requirements; and (iii) the sensitivity of the trajectories of such models to uncertainties in field characterization. As the number of interacting processes increases, the uncertainties of model parameters, initial conditions, and the processes themselves increase.

As the physical scales of models increase, the importance of the details of many of the individual processes decreases and the importance of interactions between processes increases. Thus, in order to capture the complexity of landscape evolution, it is necessary to simplify the details of models on the process level, but to increase the number of interacting processes with the increase in scale. Carried to its conclusion, this argument leads to the selection of stochastic lattice models for modeling landscape dynamics, where the dynamics of competing habitats are captured as rules for transforming one community mosaic to another through various percolation mechanisms. Emphasis is placed on emulating landscape equilibrium/disequilibrium as manifested by changing patterns of community structure, rather than on process-level descriptions of flows of energy and materials between species.

Based on consideration of the literature, neither approach is adequate on its own for environmental management. The problem is that, while the stochastic lattice approach may provide a good explanation of global landscape dynamics across scales, it will not provide information on controls for the processes of change. Consideration should therefore be given to using hybrid approaches to modeling where the objective of the model is to support landscape management. In particular, consideration should be given to methods that iterate process and stochastic lattice modeling. Here, simplified process models are used to condition percolation rules based on the results of process simulation. The global habitat patterns arising from percolation over the stochastic lattice are used to evaluate process model output, the results being input back to condition the process models. Allowed to stabilize, the coupled models would allow the emergence of control sets that are consistent with the dynamics of patterns on the landscape and with descriptions of known processes.

### **6.3 Prototype Data Fusion Techniques**

There is a definite need to make remote sensing a more useful tool for the range manager. The potential exists for integrating a selection of high- and low-resolution imagery for effective land-cover mapping using data fusion techniques.

Supervised "masking" of a CCD camera image using image-processing software was capable, but the in-house software available did not permit porting over of the bitmap segments to a

GIS package for further analysis. This exporting limitation needs to be investigated further. A CCD camera image, once georegistered, can provide training data for a supervised image classification scheme and can be used for image classification testing sites to validate and image analysis. An image can also be used for a starting point from which to begin a point extrapolation into an data array. Additionally, the image can be iconized and recalled for viewing within a GIS. Pictures are useful for illustrating integrated map data at its most basic "building block" level.

The integration of quadrat, precipitation and grazing data was successful. The process was eventually automated using ARC/INFO® macro language programming to facilitate the voluminous amounts of data to be imported. The 80+ years of georegistered data represents a lasting and valuable legacy of natural and anthropogenic change across a small piece of the Southwest desert. GPS was incorporated for locating data in an environment in which local ground control was either too sparse for geolocation or was unavailable. Rigorous evaluation of future change detection pairs requires sub-meter differential GPS sample sites to be acquired.

The use of a laptop computer in the field allows for immediate data collection in a GIS format. Sub-aerial photos can be stored and viewed interactively. If desired, the ground position of the laptop user can be denoted on the sub-aerial photo using special GPS tracking software purchased by TEC. Collection of data in the field in digital format helps to eliminate the added possibility for data transcribing errors associated with handwritten field notes.

#### **6.4 FALCON Workstation Support System**

The FALCON system supports and enhances the basic reporting needs of analysts and investigators with a capability to build situational hypotheses from fragmented data retrieved from distributed sources. One innovative feature of the system is the use of families of autonomous software agents to automate many of the data search and integration tasks that would normally need to be performed manually by the analyst. Using an agent-based approach, FALCON was capable of scanning databases to seek new evidence in order to complete or test situational hypotheses without direct user supervision. "Agents" could also interact in order to filter real-time data streams, to seek and resolve anomalous data, and to report findings.

Built upon government and industry system standards and data protocols, FALCON embodies the open-system approach to systems engineering. This approach will ensure that any future changes in standards and technology improvements will have only a minimum impact on the system components. In its current configuration, the FALCON architecture provides criminal and military investigators and analysts the communications, data, and situation analysis

capabilities necessary to analyze and monitor threat situations anywhere in the world. FALCON constructs situation development products incrementally, building from an analysis of past and current events, to the projection of future situations, culminating in the planning of proactive measures. Implemented as a population of software agents performing data capture, analysis, and integration tasks in the service of a GIS, the approach promises to transfer well to ecosystem analysis.

## **7.0 Future Work**

As discussed in Section 1.0, the Legacy Data Capture and Data Assessment Phase was intended to be the first phase of a multi-year program directed towards the development of an ecosystem management workstation for use by military environmental managers. This is still the primary goal; however, the recent DoD focus on dual-use technology produces a related goal of applying experience to the development of management systems for the public natural resource agencies and for private concerns.

The natural resource agencies are currently collaborating in the development of a nation-wide environmental information network called the NSDI. This network will provide public digital access to a very diverse collection of spatial data necessary for natural resource management. This trend reflects similar developments by the National Aeronautics and Space Administration (NASA) Earth Observing System Distribution System (EOS/DIS) for providing public access to imagery data, and for encouraging private clearing houses to distribute problem-specific environmental data via agencies such as the EPA. Such data would be available, for example, from sources accessed through the EPA/U.S. Department of Commerce "Green Pages" directory of environmental products and services.

Future work involves expansion and generalization of the prototype system developed under Phase I of this project to address the data fusion needs of private environmental consultants. Modeled on the "Green" FALCON concept, this system is envisioned as a client node on the environmental data client/server network emerging through such programs as NSDI and EOS/DIS. The ultimate goal is to develop a workstation that appears to the user as a super-GIS. Typical features would include:

- connectivity to multiple distributed data sources and tools for accessing them;
- tools for the capture of historical, site-specific data sets;
- tools for locating, collecting, and incorporating new local data sets;
- tools for performing environmental situation analysis; and
- user support through a set of user-modifiable, autonomous software agents (e.g., for the performance of routine tasks, to warn of data changes, and for embedded training).

Many data sources currently accessible through GIS systems contain a great deal of obscure information relevant to management decisions which may be released through appropriate data fusion tools. However, experience on this project indicates that this information is not

available without considerable knowledge of both the relevant environmental domain and of computing. It is often difficult for a novice to evaluate the quality of data, and it is often simple for an expert to make the wrong inferences. Future work will concentrate on providing systems that help managers to cope with domain and analytic complexity as it arises. In a military context, this would involve:

- anticipating present and future ecosystem changes contingent on natural and exercise disturbance;
- selecting an exercise area based on anticipated effects;
- monitoring the extent of exercise disturbances, and near- and long-term results of disturbances;
- planning and executing remediation activities; and
- evaluating the set of decisions and results associated with the ecosystem disturbance episode.

The relationships between these and non-military applications will be obvious.

One major result of this project was realizing the extent to which resource management is still a field science. Information is often not available at the necessary accuracy or precision levels for either assessment of the current situation or for prediction. Managers frequently need to augment archived information with new field data. Typical requirements are for field data to "ground-truth" remotely sensed data, to evaluate the current validity of historical data sets, and to compensate for scale and sampling differences. However, many available general resource databases and GISs cannot integrate field-gathered data.

Workstation development will include building field-portable systems for the automated collection of field data, and for on-site decision support. These field systems will exploit recent work in remote sensing, GIS, GPS, geostatistics, and image processing. The field system being prototyped will be extended in collaboration with TEC for rangeland inventories and assessment. Initial work has begun to integrate satellite imagery spreadsheet data and geopositioned ground-gathered digital imagery into a laptop computer. This system will be used to investigate the application of COTS image-processing tools to quantify vegetation cover and species abundance on digital ground-gathered images. Such data will allow more precisely-supervised classification and should help managers baseline classifications on a specific site, or regionally. The use of geostatistics (e.g., kriging) will be applied in field sampling to both reduce field time and improve classification accuracy.

The workstation is being integrated around the landscape visualization module. The current visualizations animate data on vegetation change and extract characteristic correlations between vegetation types. Correlations between precipitation and vegetation productivity data will be investigated in future work and would prove useful for accurate plant growth simulations in the absence of one of the variables. Moreover, predictive modeling could be validated by examining historical data and "predicting" past events, to be compared against real data at the next time interval. This visualization will be expanded into a visual language to support the examination of data sets across scales, the selection of new data sampling sites to support cross-scale interpolation, and the integration of analytic products around a problem specification.

Beyond the rhetoric of "sustainable use of natural resources" and "decision-support systems for environmental management" exists the basic need to effectively monitor landscapes. The ability to predict future resource conditions in a stochastic environment is seriously limited. Accurate hindsight will continue, for some time, to be the best tool for resource management. On-the-ground efforts to evaluate resource status and trends in response to management practices will be the most beneficial activities. The real problem facing land managers is deciding where to monitor, what to monitor, how to monitor, and when to monitor. Given the large expanses of terrestrial resources and the diverse arrays of ecosystem attributes, these decisions regarding monitoring protocols are extremely significant. With the completion of Phase I of this project, the possibility exists to thoroughly analyze legacy data to direct determination of biological, temporal, and spatial requirements for monitoring in this environment. Legacy data analyses should provide monitoring guidelines that can be tested in field pilot projects at relatively small scales. However, development of protocols for specific application to a variety of end users (e.g., public land stewards, Defense Department environmental managers, and private land owners) will require input on ecological criteria of importance and inherent resource constraints on monitoring. These inputs should be solicited following field testing of experimental protocol.

In Phase II of this ongoing project, a variety of approaches and funding sources will be explored. The following proposals have been submitted to the National Research Initiative of the U.S. Department of Agriculture (NRI), International Arid Lands Consortium (IALC), and the Western Region USDA Sustainable Agriculture Research and Education (SARE) program:

NRI	Simulation and Visualization of Snakeweed Survival, Distribution and Abundance in Response to Management Strategies
SARE	Decision Support System for Range Management
IALC	Information Visualization for the Management of Snakeweed, a Demonstration

The progress made in Phase I will be used in the context of several other initiatives in 1995-96.

## 8.0 GLOSSARY

Following is an alphabetical listing of all acronyms, abbreviations, and their meanings as used in this document.

AI	Artificial Intelligence
AIMS	Advanced Information Management System
AML	ARC Macro Language
ARS	Agricultural Research Service
CCD	charge coupled device
CEES	Committee on Earth and Environmental Sciences
CIERA	Consortium for International Environmental Research and Assistance
CIESIN	Consortium for International Earth Science Information Network
COOP	Cooperating Information Agents
COTS	commercial off-the-shelf
DIS	Distributed Interactive Simulation
DAT	Digital Analog Tape
DEM	Digital Elevation Model
DoD	Department of Defense
DoE	Department of Energy
DRP	Dynamic Resource Perturbation
EDAC	Earth Data Analysis Center
EOS/DIS	Earth Observing System Distribution System
EPA	Environmental Protection Agency
FCCSET	Federal Coordinating Council on Science, Engineering, and Technology
GEPSI	General Plant Simulator
GIS	Geographic Information System
GPS	Global Positioning System
GUI	Graphical User Interface
GVI	Greenness Vegetation Index
IALC	International Arid Lands Consortium
IEMS	Integrated Environmental Management System
JDR	Jornada Data Rescue
JER	Jornada Experimental Range
I&W	indication and warning
ISODATA	Iterative Self-Organizing Data Analysis Technique
LCTA	Land Condition Trend Analysis
MSS	Landsat Multispectral Scanner
NAD 27	North American Datum of 1927
NASA	National Aeronautics and Space Administration
NDVI	Normalized Difference Vegetation Index

NMSU	New Mexico State University
NRI	National Research Initiative of the U.S. Department of Agriculture
NSDI	National Spatial Data Infrastructure
NSF	National Science Foundation
OU	The Ohio University
PALS	Patch Arid Lands Simulation
PC	Personal Computer
PSL	Physical Science Laboratory
Rebar	Reinforcement bar
SAS	Situation Analysis System
SARE	Sustainable Agriculture Research and Education
SAVI	Soil-Adjusted Vegetation Index
SDSU	San Diego State University
SERDP	Strategic Environmental Research and Development Program
SERECO	Simulation of Ecosystem Response to Elevated CO <sub>2</sub> and Climate Change
SGI	Silicon Graphics
TEC	U.S. Topographic Engineering Center
TIN	Triangulated Irregular Network
TM	Landsat Thematic Mapper
UNM	University of New Mexico
USDA/ARS	U.S. Department of Agriculture/Agricultural Research Service
USGS	U.S. Geological Survey
UTM	Universal Transverse Mercator
WSMR	White Sands Missile Range
W3	World Wide Web

**APPENDIX A  
SAMPLE QUADRAT ANNOTATION LIST**



Pa	Panicum sp.	0114
Ap	Panicum sp.(unknown)	0014
G	Bouteloua eriopoda	0046
A	Aristida sp.	0033
Aa	Aristida adscensionis	0028
Ag	Bouteloua sp.	0048
T	Cassia bauhinioides	0050
Gl	Pectis angustifolia	0115
Ev	Evolvulus nuttallianus	0074
Pu	Portulaca sp.	0124
Sp	Euphorbia albomarginata	0069
Hy	Hymenopappus flavescens	0086
Er	Eriogonum annuum	0065
Mr	Tidestromia lanuginosa	0141
Fl	Linum vernale	0099
Sa	Bahia absinthifolia	0039
Hj	Caesalpinia jamesii	0049
Gu	Gutierrezia sarothrae	0079
Ho	Caesalpinia jamesii	0049



**APPENDIX B  
REFERENCES**



## PLANT IDENTIFICATION REFERENCES

ALLRED, K.W. [1988], A Field Guide to the Flora of the Jornada Plain. New Mexico State University Agric. Exp. Sta. Bull-739.

ALLRED, K.W. [1993], A field guide to the grasses of New Mexico. New Mexico State University Department of Agricultural Communications.

CORRELL, D.S. and M.C. JOHNSTON [1970], Manual of the Vascular Plants of Texas (Contributions from Texas Research Foundation), Texas Research Foundation, Renner, Texas.

GIBBENS, R.P. Research consultant to USDA-ARS-Jornada Experimental Range: Personal communication.

KEARNEY, T.H., and R.H. Peebles [1960], Arizona Flora. University of California Press, Berkley.

WOOTON, E.O. and P.C. Standley [1915], Flora of New Mexico (Contributions from the United States National Herbarium, Volume 19), Washington Government Printing Office.

## BIBLIOGRAPHICAL REFERENCES

AARTS, E. and J. KORST [1989], *Simulated Annealing and Boltzmann Machines*, John Wiley and Sons, New York, NY.

ATKIN, R. [1972], From Cohomology in Physics to Q-Connectivity in Social Science, *International Journal of Man-Machine Studies*, 4:139-167.

ATKIN, R. [1974]. An Algebra for Patterns on a Complex, I, *International Journal of Man-Machine Studies*, 6:285-307.

ATKIN, R. [1976]. An Algebra for Patterns on a Complex, II. *International Journal of Man-Machine Studies*, 8:499-500.

BROOKS, D.R. and E.O. WILEY [1988], *Evolution as Entropy: Towards a Unified Theory of Biology*, University of Chicago Press, Chicago.

CASTI, J. [1980], *Connectivity, Complexity, and Catastrophe in Large-Scale Systems*, John Wiley and Sons, New York.

CHEN, JIA-LIN and J.F. REYNOLDS [1993], A Generic Plant Growth Simulator in Object-Oriented Programming Language C++, Department of Botany, Duke University, Durham.

CLEMENTS, F.E. [1936], Nature and Structure of the Climax, *Journal of Ecology*, 24:252-284.

COHEN, J.E., F. BRIAND and C.M. NEWMAN [1990], *Community Food Webs*, Springer-Verlag, Berlin.

COMMITTEE ON EARTH AND ENVIRONMENTAL SCIENCES (CEES) [1992], *Our Changing Planet: The FY 1993 U.S. Global Change Research Program, A Report by the Committee on Earth and Environmental Sciences (CEES)*, Washington, D.C., pp. 79.

COOMBS, M.J., R.T. HARTLEY and H.D. PFEIFFER [1990], *Developing Computing Technology for Modeling Enemy Intentions. Final Report, Work Order No. 161A*, U.S. Army Atmospheric Sciences Laboratory, White Sands Missile Range.

COOMBS, M.J., SHERWOOD, E.M. and MORRISON, J.D. [1991], *Symbolic Processing for the Support of Intelligence Analysis in Low-Intensity Conflict. Technical Report, Computing Research Laboratory, Contract No. DAEA18-90-C-0046*, Defense Advanced Research Projects Agency.

- COOMBS, M.J., PFEIFFER, H.D. and HARTLEY, R.T. [1992], E-MGR: An Architecture for Symbolic Plasticity, *International Journal of Man-Machine Studies*, 36:247-263.
- COOMBS M.J. and SRIKANT, M. (1994), *Statistical Mechanical/Dynamic Learning of Evolving Trajectories in a Competitive Combinatorial System*, A Proposal to the Army Research Office, Research Triangle Park, NC.
- FENCHEL, T [1987], *Ecology - Potentials and Limitations*, Ecology Institute, Luhe, FRG.
- FISHER, K.H. and J.A. HERTZ [1991] *Spin Glasses*, Cambridge University Press, Cambridge.
- FLAMM, R.O. and M.G. TURNER [1994], Alternative Model Formulation for a Stochastic Simulation of Landscape Change, *Landscape Ecology*, 9(1):37-46.
- FRIDEL, M.H. [1991], Range Condition Assessment and the Concept of Thresholds: A Viewpoint, *Journal of Range Management*, 44:422-426.
- GARDNER, R.H., B.T. MILNE, M.G. TURNER, and R.V. O'NEILL [1987], Neutral Models for the Analysis of Broad-Scale Landscape Pattern, *Landscape Ecology*, 1:19-28.
- GLEASON, H.A. [1939]. The Individualistic Development of the Plant Association, *American Midland Naturalist*, 21:92-110.
- GOSZ, J.R. [1993], Ecotone Hierarchies, *Ecological Applications*, 3:369-376.
- GOUDRIAAN, J. [1977], *Gap Micrometeorology: A Simulation Study*, Simulation Monographs, Pudoc, Wageningen.
- GREEN, D.G. [1993], Emergent Behavior in Biological Systems. In D.G. Green and T.J. Bossomaier (ed.), *Complex Systems - From Biology to Computation*. Amsterdam: IOS Press.
- HALL, F.G., D.E. STREBEL and P.J. SELLERS [1988], Linking Knowledge Among Spatial and Temporal Scales: Vegetation, Atmosphere, Climate and Remote Sensing, *Landscape Ecology*, 2(1):3-22.
- HALLAM, T.G., L.J. GROSS and S.A. LEVIN [1988], *Mathematical Ecology*, World Scientific Publishing Co. Pt. Ltd., Singapore.

HAYNES, D.L., BRABDENBURG, R.A., and FISHER, P.D. [1973], Environmental Monitoring Networks for Pest Management Systems, *Environmental Entomology*, 2:889-899.

HAYNES, D.L., TUMMALA, R.L., and RUESINK, W.G. [1975], A Discrete Component Approach to the Management of the Cereal Leaf Beetle Ecosystem, *Environmental Entomology*, 4:175-186.

HAYNES, D.L. and TUMMALA, R.L. [1977], On-Line Pest Management Systems, *Environmental Entomology*, 6:393-349.

HAYNES, D.L., TAMMALA, R.L., and ELLIS, T.L. [1980], Ecosystem Management for Pest Control, *BioScience*, 30:690-696.

HAYNES, D.L. and SAWYER, A.J. [1985]. Simulating the Spatiotemporal Dynamics of the Cereal Leaf Beetle in a Regional Crop System, *Ecological Modeling*, 30:83-104.

HENEGBRY, G.M. [1993], Detecting Change in Grasslands Using Measures of Spatial Dependence with Landsat TM Data, *Remote Sensing of Environment*, 46:223-234.

HIGASHI, M. and T.P. BURNS [1991], *Theoretical Studies of Ecosystems, the Network Perspective*, Cambridge University Press, Cambridge.

HÖM, R.A. and JOHNSON, D.R. [1990], *Matrix Analysis* Cambridge, Cambridge University Press.

HUETE, A.R. [1988], A Soil-Adjusted Vegetation Index (SAVI), *Remote Sensing of Environment*, 25:295-309.

HUETE, A.R. and R.D. JACKSON [1984], Suitability of Spectral Indices for Evaluating Vegetation Characteristics on Arid Rangelands, *Remote Sensing of Environment*, 23:213-232.

HUTCHINSON, C.F. and P.L. WARREN [1983], *Environmental Sampling for Monitoring Rangeland Conditions*, Office of Arid Land Studies, University of Arizona, Tucson, 52p.

JAYNES, E.T. [1957], Information Theory and Statistical Mechanics, *Physical Reviews*, 106:620-630.

JIA-LIN, CHEN and J.F. REYNOLDS [1994], A Generic Plant Growth Simulator (GEPsi) in Object-Oriented Programming Language C++, Unpublished Draft Report, Department of Botany, Duke University, Durham, NC.

KAPUR, J.N. and H.K. KESAVAN [1992], *Entropy Optimization Principles with Applications*, Academic Press, New York.

KAUFFMAN, S.A. [1989], *Principles of Adaptation in Complex Systems*. In D. Stein (ed.), *Lectures in the Sciences of Complexity*, Addison-Wesley Longman, New York.

LANGTON, C.G. [1990], *Computation on the Edge of Chaos*, *Physica*, 42:12-37.

LANGTON, C.G. [1992], *Life on the Edge of Chaos*. In C.G. LANGTON, C. TAYLOR, J. DOYNE FARMER, and S. RASMUSSEN (eds.), *Artificial Life II*, New York, NY: Addison-Wesley.

LAYCOCK, W.A. [1991], *Stable States and Thresholds of Range Conditions on North American Rangelands: A Viewpoint*, *Journal of Range Management*, 44:427-432.

LEVINS, R. [1977]. *The Search for the Macroscopic in Ecosystems*. In G.S. INNES (ed.), *New Directions in the Analysis of Ecological Systems II*, La Jolla, CA: Simulation Councils.

LI, H. and J.F. REYNOLDS [1993], *On Definition and Quantification of Heterogeneity: Toward an Ecological Paradigm*, Department of Botany, Duke University, Durham.

LI, H. and J.F. REYNOLDS [1993], *A Simulation Experiment to Quantify Spatial Heterogeneity*, Department of Botany, Duke University, Durham.

LIEBMANN, R. [1986], *Statistical Mechanics of Periodic Frustrated Ising Systems*, *Lecture Notes in Physics* 251. Berlin, FRG:Springer-Verlag.

LOCKWOOD, J.A. and LOCKWOOD, D.R. [1993], *Catastrophe Theory: A Unified Paradigm for Rangeland Ecosystem Dynamics*, *Journal of Range Management*, 46:282-288.

MADALA, H.R. and A.G. IVANENKO [1994], *Inductive Learning Algorithms for Complex Systems Modeling*, CRC Press, Inc., London.

MAY, R.M. [1981], *Theoretical Ecology, Principles and Applications*, Blackwell Scientific Publications, Sunderland, MA.

MOONEY, H.A. and M. GORDON [1983], *Disturbance and Ecosystems*, Springer-Verlag, Berlin.

NEAL, R.M. [1993], Probabilistic Inference Using Markov Chain Monte Carlo Methods, Technical Report CRG-TR-93-1, Department of Computer Science, University of Toronto, Canada.

NICOLIS, G. and I. PRIGOGINE [1989], Exploring Complexity, W.H. Freeman and Company, New York.

NORMAN, J.M. [1982], Simulation of Microdiameter. In MATFIELD, J. and THOMASON, I., Biometeorology in Integrated Pest Management, Academic Press, New York.

OLIVER, M.A. and R. WEBSTER [1990], Kriging: A Method of Interpolation for Geographical Information Systems, *Int. J. Geographical Information Systems* 4:313-332.

O'NEILL, R.V., KRUMMEL, J.R., GARDNER, R.H., SUGIHARA, G., and JACKSON, B. (1988), Indices of Landscape Pattern, *Landscape Ecology*, 1:153-162.

OTTEN, R.H.J.M. and L.P.P.P. VAN GINNEKEN [1989], The Annealing Algorithm, Kluwer Academic Publishers, Boston.

PICKUP, G. [1994], Modeling Patterns of Defoliation by Grazing Animals in Rangelands, *Journal of Applied Ecology*, 31:231-246.

PICKUP, G.M., V.H. CHEWINGS and D.J. NELSON [1993], Estimating Changes in Vegetation Cover over Time in Arid Rangelands using Landsat MSS Data, *Remote Sensing of Environment*, 43:243-263.

PIJANOWSKI, B.C., T. EDENS, K. PAUSTIAN, S. GAGE, and P. WEBBER [1992], An Assessment of USDA Models for Global Environmental Change Research, Entomology Spatial Analysis Laboratory, Michigan State University for Consortium for International Earth Science Information Network (CIESIN), Contract No. 53-3k06-2-1-6.

PLOTNIK, R.E. and GARDNER, R.H. [1993], Lattices and Landscapes. In GARDNER, R.H., Predictory Spatial Effects in Ecological Systems, *American Mathematical Journal*, pp. 129-157.

POMEROY, L.R. and J.J. ALBERTS [1988], Concepts of Ecosystem Ecology, Springer-Verlag, New York.

PRUSINKIEWICZ, P. and A. LINDENMAYER [1990], The Algorithmic Beauty of Plants, Springer-Verlag.

PUTMAN, R.J. and S.D. WRATTEN [1984], Principles of Ecology, University of California Press, Berkeley.

REYNOLDS, J.F., R.A. VIRGINIA and W.H. SCHLESINGER [1993], Defining Functional Types for Models of Description. In Some Kind of Book on Functional Types, Cambridge University Press, Cambridge.

SCHLESINGER, W.H., J.F. REYNOLDS, G.L. CUNNINGHAM, L.F. HUENNEKE, W.M. JARRELL, R.A. VIRGINIA and W.G. WHITFORD [1990], Biological Feedbacks in Global Desertification, Science, Vol. 247:1043-1048.

SRIKANT, M. [1994], Aspects of Combinatorial Dynamics, Internal Memo, Computing Research Laboratory, NSF Grant No. 9122401, National Science Foundation.

SRIKANT, M. and COOMBS, M.J. [1993], Note on Combinatorial Information. Preliminary Report, Computing Research Laboratory, NSF Grant No. 9122401, National Science Foundation.

STEELE, M.J. and D. ALDOUS [1992], Introduction. In National Research Council's Probability and Algorithms, National Academy Press, Washington, D.C.

STEIN, D.L. [1989], Disordered Systems: Mostly Spin Glasses. In D. STEIN (ed.), Lectures in the Sciences of Complexity, Addison-Wesley Longman, New York.

TOFOLLI, T. and N. MARGOLUS [1987], Cellular Automata Machines, MIT Press, Boston.

TURNER, M.G., WU YEGANG, W.H. ROMME and L.L. WALLACE [1993], A Landscape Simulation Model of Winter Foraging by Large Ungulates, Ecological Modeling, 69:163-184.

TURNER, M.G., W.H. ROMME, R.H. GARNER, R.V. O'NEILL and T.K. KRATZ [1993], A Revised Concept of Landscape Equilibrium: Disturbance and Stability on Scaled Landscapes, 8(3):213-277.

TURNER, M.G. and R.H. GARDNER [1990], Quantitative Methods in Landscape Ecology, Springer-Verlag, New York.

TURNER, M.G. [1989], Landscape Ecology: The Effect of Pattern on Process, Annual Review of Ecological Systems, 20:171-197.

TURNER, M.G., DALE, V.H., and GARDNER, R.H. (1989). Predicting Across Scales: Theory Development and Testing, *Landscape Ecology*, 3:245-252.

TURNER, M.G. [1988], A Spatial Simulation Model of Land Use Changes in a Piedmont County in Georgia, *Applied Mathematics and Computation*, 27:39-51.

TURNER, M.G. [1987], Spatial Simulation of Landscape Changes in Georgia: A Comparison of 3 Transition Models, *Landscape Ecology*, 1(1):29-36.

UENO, Y. [1986]. Cluster Model for Non-Equilibrium Relaxation in Spin Glasses. In I.A. CAMPBELL and C. GIOVANNELLA (eds.), *Relaxation in Complex Systems and Related Topics*, NATO ASI Series. New York, NY:Plenum Press.

ULANOWICZ, R.E. [1989]. A phenomenology of evolving networks. *Systems Research*, 6:209-217.

ULANOWICZ, R.E. [1986], *Growth and Development: Ecosystems Phenomenology*, Springer-Verlag, New York.

VINCENT, E., HAMMANN, J., and OCIO, M. [1992], Slow Dynamics in Spin Glasses and Other Complex Systems. In D.H. RYAN (ed.), *Recent Progress in Random Magnets*, Singapore: World Scientific.

WATT, A.S. [1947]. Pattern and Process in Plant Communities, *Journal of Ecology*, 35:1-22.

WESTBY, M., WALKER, B., and NOY-MEIR-NOY [1989], *Journal of Range Management*, 42:266-274.

WEINBERGER, E.D. and P.F. STADLER [1993], Why Some Fitness Landscapes are Fractal, SFI Report, Santa Fe Institute, Santa Fe, NM.

WEINBERGER, E. [1990], Correlated and Uncorrelated Fitness Landscapes and How to Tell the Difference, *Biological Cybernetics*, 63:325-336.

WESTMAN, W.E. [1985], *Ecology, Impact Assessment, and Environmental Planning*, John Wiley and Sons, Inc., New York.

WESTOBY, M., B. WALKER and I. NOY-MEIR [1989], Opportunistic Management for Rangelands not at Equilibrium, *Journal of Range Management*, 42(4):266-274.

WICKEN, J.S. [1987], *Evolution, Thermodynamics, and Information: Extending the Darwinian Program*, Oxford University Press, Oxford.

WONDZELL, S.M., CUNNINGHAM, G.L., and BACHELET, D. [1987]. A Hierarchical Classification of Landforms: Some Implications for Understanding Local and Regional Vegetation Dynamics. Symposium on Strategies for Classification and Management of Natural Vegetation for Food Production in Arid Zones, Tuscon, AZ, October 12-16, 1987.



**APPENDIX C  
MASTER BOTANICAL LIST**



Aa/Aristida adscensionis/0028/Aa  
 Aad/Aristida adscensionis/0028/Aad,y,X  
 Aco(1) (contour)/Acacia constricta/0002/Aco  
 Aco(2) (point)/Schranksia occidentalis/0011/Aco  
 Acuan/Schranksia occidentalis/0011/X,Aco  
 Ad/Aristida divaricata/0029/Ad  
 Ad seedling/Aristida divaricata/0029/Ad  
 Adi/Aristida divaricata/0029/Adi  
 Adl/Aristida divaricata/0029/Adl  
 Ain/Allionia incarnata/0021/Ain  
 Alkali Sakaton/Sporobolus airoides/0135/Sai,S  
 Allaturia incarnata/Allaturia incarnata/0020/Alainc  
 Allinc/Allaturia incarnata/0020/Allinc  
 Alo/Aristida purpurea v. longesita/0032/Alo  
 Amaranthus retroflexus/Amaranthus retroflexus/0022/Amaret  
 Amaret/Amaranthus retroflexus/0022/Amaret  
 Amsinkia/Amsinkia sp./0023/Am  
 Andropogon saccharoides/Bothriochloa saccharoides/0043/Al  
 Angra albicaulis/Oenothera albicaulis/0109/Ai  
 Annual 3A/Aristida adscensionis/0028/Aa  
 Annual/Boerhaavia spicata/0042/Bt,Apa,A  
 Annual ARI/Aristida adscensionis/0028/ARI,Aa  
 Annual Aristida/Aristida adscensionis/0028/Aa,Ag,Ari,Aar  
 Annual Bouteloua/Bouteloua sp./0048/B,Bb,  
 Annual composite/!forb/0000/Ac  
 Annual eriogonum/Eriogonum annuum/0065/Er  
 Annual forb/!forb/0000/Af  
 Annual forb seedlings/!forb/0000/Afs  
 Annual golden weed/Machaeranthera gracilis/0186/Aplgras  
 Annual grama/Bouteloua sp/0048/Ag,G,Bba,Ga,Bb,Bar  
 Annual grass/!grass/0001/X  
 Annual g-A/!grass/0001/Aa  
 Annual grasses/!grass/0001/X  
 Annual low tridens/Dasyochloa pulchella/0061/Alt  
 Annual panic grass/Panicum sp.(unknown)/0014/Ap  
 Annual panicum /Panicum sp.(unknown)/0014/Ap,Aa,Apa,Pa  
 Annual selenocarpus/Ammocodon chenopodioides/0200/Sc  
 Annual snakeweed/Gutierrezia sphaerocephala/0080/AnRb  
 Annual sphaeralcea/Boerhaavia spicata/0042/Bt  
 Annual spiderling/Boerhaavia sp./0041/Bt  
 Annual three awn/Aristida adscensionis/0028/AP,Aa,An,x

Annual weed/!forb/0000/z  
Annual/Panicum sp./0114/Apa  
Anogra albicaulis/Oenothera albicaulis/0109/Ai,X2  
Anogra runcinata/Oenothera runcinata/0110/Ac,X9  
Anu/Astragalus nuttallianus/0036/Anu  
Apa(1) (point)/Panicum sp./0114/Apa  
Apa(2) (contour)/Aristida pansa/0030/Apa  
Aphanostephus/Aphanostephus sp./0025/Af  
Aphanostephus namessimus/Aphanostephus ramosissimus/0024/Ara  
Aphanostephus ramosissimus/Aphanostephus ramosissimus/0024/Af,Aj,Ara,Ar  
Aphram/Aphanostephus ramosissimus/0024/Aphram  
Aplopappus australis/Aplopappus sp./0027/Au,Ak  
Aplopappus spiney sideranthus/Aplopappus sp./0027/Au  
Apo/Aplopappus sp./0027/Apo  
Apra/Aphanostephus ramosissimus/0024/Apra  
Apsp/Machaeranthera pinnatifida/0190/Apsp  
Ara/Aphanostephus ramosissimus/0024/Ara  
Ardi/Aristida divaricata/0029/Ardi  
Ari/Aristida sp./0033/Ari  
Aristida/Aristida sp./0033/A,Alo,O,Ari,Ap  
Aristida adscensionis/Aristida adscensionis/0028/Aa  
Aristida annual/Aristida adscensionis/0028/Aa,A,Ari  
Aristida divaricata/Aristida divaricata/0029/Ad,Adi  
Aristida longesita/Aristida purpurea v. longesita/0032/Al,Ae,Alo,A  
Aristida pansa/Aristida pansa/0030/Apa,An,Ap  
Aristida purpurea/Aristida purpurea/0031/Ap,A  
Aristida sp./Aristida sp./0033/A,Al  
Aristida seedling/Aristida sp./0033/A,As  
Arlo/Aristida purpurea v. longesita/0032/Arlo  
Artemisia spp./Artemisia spp./0035/ArB  
Aster leucelene/Leucelene ericoides/0097/Ha,Ale  
Astragalus/Astragalus nuttallianus/0036/Na,Aal  
Astragalus crassicaupus/Astragalus crassicaupus/0164/Acr,Ca  
Astragalus nutt./Astragalus nuttallianus/0036/Na  
Astragalus nuttallianus/Astragalus nuttallianus/0036/Na,Anu  
Atriplex canescens/Atriplex canescens/0038/AB  
B/Bouteloua eriopoda/0046/B  
B. aristidoides/Bouteloua sp./0048/Bs  
B. barbata/Bouteloua barbata/0045/Bb,B  
B. eriopoda/Bouteloua eriopoda/0046/B,O  
B. grama/Bouteloua eriopoda/0046/B,G,Ber  
B. parryii/Bouteloua parryi/0047/Bpa

Ba/Baileya multiradiata/0040/Ba  
 Bab/Bahia absinthifolia/0039/Bab  
 Bahia/Bahia absinthifolia/0039/Bahabs, Bahats  
 Bahia Dealbata/Bahia absinthifolia/0039/Bd, Ba, Sa  
 Baileya multiradiata/Baileya multiradiata/0040/Bm, Bmu, Ba  
 Baileya radiata/Baileya multiradiata/0040/Ba  
 Baileya/Baileya multiradiata/0040/By, Bm, Ba  
 Baimul/Baileya multiradiata/0040/Baimal  
 Bamu/Baileya multiradiata/0040/Bamu  
 Bb/Bouteloua barbata/0045/Bb  
 Bba/Bouteloua barbata/0045/Bba, x, y  
 Beard Scale/Enneapogon desvauxii/0063/Bd  
 Beard Scale grass/Enneapogon desvauxii/0063/Bs, Bd  
 Ber/Bouteloua eriopoda/0046/Ber, O  
 Beto/Boerhaavia spicata/0003/Beto  
 BJM/BJM(unknown)/0148/BJM  
 Bl. pod/Lesquerella sp./0096/Bp  
 black grama/Bouteloua eriopoda/0046/B, Ber, G, O  
 Bladder Pod/Lesquerella sp./0096/Bp  
 blue wooly weed/Evolvulus nuttallianus/0074/BL  
 Bm/Baileya multiradiata/0040/Bm  
 Bmu/Baileya multiradiata/0040/Bmu  
 Boer/Bouteloua eriopoda/0046/Boer  
 Boerhaavia torreyana/Boerhaavia spicata/0042/Bt, Bo, Bh, Bto  
 Boerhaavia/Boerhaavia sp./0041/Bt, Bo, Bh  
 Boetor/Boerhaavia spicata/0042/Boetor  
 Bout an./Bouteloua barbata/0045/Bb  
 Bouteloua annual/Bouteloua barbata/0045/Bb, Ag  
 Bouteloua aristidoides/Bouteloua aristidoides/0044/B, Ba, Bb, Bar  
 Bouteloua barbata/Bouteloua barbata/0045/Bb, Bba  
 Bouteloua eriopoda/Bouteloua eriopoda/0046/B, Ber, Be, O, G  
 Bouteloua panicum/Bouteloua sp./0048/Bb  
 Bouteloua parryii/Bouteloua parryi/0047/Bp, Bb  
 Bouteloua/Bouteloua sp./0048/O, B, G  
 Bpa/Bouteloua parryi/0047/Bpa  
 Broad-leaved Eriogonum/Eriogonum sp./0068/Eb  
 Broom snakeweed/Gutierrezia sarothrae/0079/Gutsar  
 Brown Berries/Brown Berries(unknown)/0174/Bb  
 Bt/Boerhaavia spicata/0042/Bt  
 Bto/Boerhaavia spicata/0042/Bto, Xa  
 Bunch grass/Muhlenbergia torreyi/0180/Bu

Burro/Scleropogon brevifolius/0129/B  
Burro grass/Scleropogon brevifolius/0129/B,Sb,Sbr,O  
burrograss/Scleropogon brevifolius/0129/B,Sb,Sbr  
Burrow/Scleropogon brevifolius/0129/B  
bush muhly/Muhlenbergia porteri/0104/Mp  
Bushy Senecio/Senecio sp./0167/Sb  
Ca/Euphorbia albomarginata/0069/Ca  
Cab/Cassia bauhinioides/0050/Cab  
Caba/Cassia bauhinioides/0050/Caba,O  
Cactus/cactus(unknown)/149/Ca,OB  
Cactus (round)/cactus(unknown)/149/Ca  
Cal/Euphorbia albomarginata/0069/Cal  
Calceblaria verticillata/Hybanthus verticillatus/0211/Cv  
Cas/Cassia bauhinioides/0050/Cas  
Casbau/Cassia bauhinioides/0050/Casbau  
Cassia b/Cassia bauhinioides/0050/Cb  
Cassia bauhinioides/Cassia bauhinioides/0050/Cb,Casbau,Cba  
Cb/Cassia bauhinioides/0050/Cb  
Cba/Cassia bauhinioides/0050/Cba  
Cbh/Cassia bauhinioides/0050/Cbh  
Cbo/Cassia bauhinioides/0004/Cbo  
Cco/Croton pottsii/0054/Cco  
Ccon/Chamaesaracha sordidia/0168/Ccon  
Ccr/Croton pottsii/0054/Ccr  
Ceon/Ceon(unknown)/0176/Ceon  
Cg/Croton pottsii/0054/Cg  
Chamaesaracha/Chamaesaracha sordidia/0168/ChaCon,Cham,Cha,Ch  
Chamaesaracha conioides/Chamaesaracha sordidia/0168/Ch  
Chamaesaracha sp./Chamaesaracha sp./0192/Ch  
Chamaesyce/Euphorbia sp./150/Ca,Sr  
Chamaesyce albo/Euphorbia albomarginata/0069/Ca,X  
Chamaesyce albomarginata/Euphorbia albomarginata/0069/Ca,Cj,Co,Cal  
Chamaesyce flagelliformis/Euphorbia parryi/0072/Cf,Bf  
Chamaesyce neomexicana/Euphorbia neomexicana/0071/Cx,Cn,Cne,Ca  
Che/Chenopodium incanum/0051/Che  
Cheinc/Chenopodium incanum/0051/Cheinc  
Chen/Chenopodium sp./0183/Chen  
Chenopodium incanum/Chenopodium incanum/0051/O,Cheinc,Cp  
Chenopodium incisum/Chenopodium incanum/0051/Ch  
Chenopodium/Chenopodium incanum/0051/Cu,Cheinc,Cn,Cp  
Chi/Chenopodium incanum/0051/Chi  
Cin/Chenopodium incanum/0051/Cin

Cmi/Cryptantha micrantha/0005/Cmi  
 Cne/Euphorbia neomexicana/0071/Cne  
 Cni/Corispermum nitidum/0052/Cni  
 CO/CO(unknown)/151/CO  
 common parsleine/Portulaca sp./0124/Purple  
 common pursley/Portulaca oleracea/0123/Potole, Porole  
 Conanthus hispidus>Nama hispidum/0107/Hc, Xi, Chi  
 Conanthus>Nama hispidum/0107/Hc  
 Corispermum nitidum/Corispermum nitidum/0052/Bk  
 Cornit/Corispermum nitidum/0052/Cornit  
 Corydalio/Condalia sp./0006/Co  
 Corydalis/Condalia sp./0006/Co  
 CP/Croton pottsii/0054/CP  
 Cq/Croton pottsii/0054/Cq  
 Crco/Croton pottsii/0054/Crco  
 CrCr/Cryptantha crassisepala/0055/CrCr  
 Creosote bush/Larrea tridentata/0092/CB  
 Crocor/Croton pottsii/0054/Crocor  
 Croton corymbulosus/Croton pottsii/0054/Cg, Cco, Cq  
 Croton lateovirons/Croton luteovirons/0053/Cd  
 Croton pottsii/Croton pottsii/0054/Cg, Cq  
 croton/Croton pottsii/0054/Cg, Crocon, Le, Cq  
 Crpu/Croton pottsii/0007/Crpu  
 Crycra/Cryptantha crassisepala/0055/Crycra  
 Cryptantha/Cryptantha crassisepala/0055/Ce, Un, x  
 Cryptanthe crassisepala/Cryptantha crassisepala/0055/Cn, Ce, Ccr  
 Curved tube flower/Penstemon sp./0118/Cu, Cf  
 Cx/Euphorbia neomexicana/0071/Cx  
 Cyperus uniflorus/Cyperus uniflorus/0057/C  
 Cyperus/Cyperus sp./0056/C  
 Depi/Descurania pinnata/0203/Depi  
 Desert Bailey/Baileya multiradiata/0040/Baimul  
 Dit/Dithyrea wislizenii/0062/Dit  
 Dithyrea wislizeni/Dithyrea wislizenii/0062/Dw, Dwi  
 Dithyrea/Dithyrea wislizenii/0062/Dw  
 Ditwis/Dithyrea wislizenii/0062/Ditwis  
 Dropseed/Sporobolus sp./0139/D  
 Dwarf dropseed/Sporobolus nealleyi/0182/D  
 Dwarf Pea/Astragalus nuttallianus/0036/Dp  
 Dw/Dithyrea wislizenii/0062/Dw  
 Dwi/Dithyrea wislizenii/0062/Dwi

Ea/Eriogonum annuum/0065/Ea  
Eab/Eriogonum abertianum/0064/Eab,Xb  
Eal/Euphorbia albomarginata/0069/Eal  
Ean/Eriogonum annuum/0065/Ean  
Eb/Erigeron ballidiastrum/0152/Eb  
Eba/Erigeron ballidiastrum/0152/Eba  
Erigeron (white broad leafed)/Erigeron sp./0153/Eb,En  
Edo/Eriastrum diffusum/0154/Edo  
Eja/Eriogonum jamseii/0066/Eja  
Eo/Evolvulus sp./0075/Eo  
Epi/Eriogonum abertianum/0064/Epi,Xb  
Epu/Dasyochloa pulchella/0061/Epu,x  
Er/Eriogonum sp./0068/Er  
Eri/Eriogonum sp./0068/Eri  
Eriabe/Eriogonum abertianum/0064/Eriabe,Ey  
Eriog trichopodium/Eriogonum sp/0068/Et  
Eriog/Eriogonum sp./0068/Er  
Eriogonum abertianum/Eriogonum abertianum/0064/Ea,En,Ev  
Eriogonum annuum/Eriogonum annuum/0065/Er,Ea,Ean  
Eriogonum occidentalis/Eriogonum sp./0068/Ea  
Eriogonum rotundifolium/Eriogonum rotundifolium/0067/Ew  
Eriogonum, sp./Eriogonum sp./0068/Et  
Eriogonum trichopodium/Eriogonum sp./0068/Et  
Eriogonum/Eriogonum sp./0068/E,Eriabe,Er,Ea,Ew,Eg  
Erioneuron pulchellum/Dasyochloa pulchella/0061/Tr,Tp  
Erirot/Eriogonum rotundifolium/0067/Erirot,Ew  
Ero/Eriogonum rotundifolium/0067/Ero,Ew,X-6  
erro/Eriogonum rotundifolium/0067/erro  
Erpu/Dasyochloa pulchella/0061/Erpu  
Eupalb/Euphorbia albomarginata/0069/Eupalb  
Euphorbia albomarginata/Euphorbia albomarginata/0069/Eupalb  
Euploc/Euploca convolvulacea/0073/Eu  
Euploca convolvulacea/Euploca convolvulacea/0073/Eu,Es  
Evening Primrose/Oenothera sp./0170/Pr  
Evolvulus pilosus/Evolvulus nuttallianus/0074/Ev,X4,Ep,Epi  
Evolvulus plosis/Evolvulus nuttallianus/0074/Ev,X4  
Evolvulus nuttallianus/Evolvulus nuttallianus/0074/Er  
Evolvulus/Evolvulus sp./0075/Ev  
Evpi/Evolvulus nuttallianus/0074/Evpi  
Ew/Eriogonum annuum/0065/Ew,Ewt  
Ey/Eriogonum abertianum/0064/Ey  
false buffalograss/Munroa squarrosa/0106/Msq

false phlox/false phlox(unknown)/0179/Fp  
 false white crucifer/Eriogonum annuum/0065/FWh  
 Festuca/Festuca sp./0076/F,Fe  
 fine-leaf Eriogonum/Eriogonum sp./0068/Ef  
 fine-leaf white Eriogonum/Eriogonum sp./0068/Ef  
 fine-leaved Aristida/Aristida purpurea/0031/AP  
 fine leaved 3 awn/Aristida sp./0033/AP,Al  
 Fla/Caesalpinia jamesii/0049/Fla  
 Flat Pod Pea/Caesalpinia jamesii/0049/FI  
 flax/Linum vernale/0099/FI  
 fluff grass/Dasyochloa pulchella/0061/Tr, Tp, Tpu, Epu  
 four-wing saltbush/Atriplex canescens/0038/AB  
 G/Bouteloua eriopoda/0046/G  
 Gaillardia/Gaillardia sp./0077/Ga  
 Gaillardia pinnatifida/Gaillardia pinnatifida/0191/Gp  
 Gaillardia-Red Eye/Gaillardia sp./0077/Gd  
 Gapi/Gaillardia pinnatifida/0191/Gapi  
 GB/Gutierrezia sarothrae/0079/GB  
 Gga/Gutierrezia sarothrae/0008/Gga  
 Gilia/Gilia sp./0171/Gi  
 Gland leaf/Pectis angustifolia/0115/GI  
 Globe Mallow/Sphaeralcea subhastata/0134/Ma, Mg, SphSub  
 Goathead/Tribulus terrestris/0143/Triter  
 Goosefoot/Chenopodium incanum/0051/Cheinc  
 grama gr./Bouteloua eriopoda/0046/G, B, Ber, O  
 grama grass/Bouteloua eriopoda/0046/G  
 grama grass seedling/Bouteloua sp./0048/Gs  
 grama/Bouteloua eriopoda/0046/G  
 grass seedling/!grass/0001/s, g, X, Gun  
 grass/!grass/0001/Gun  
 Gsa/Gutierrezia sarothrae/0079/Gsa  
 Gsp/Gutierrezia sphaerocephala/0080/Gsp  
 Gusa/Gutierrezia sarothrae/0079/Gusa  
 Gusp/Gutierrezia sphaerocephala/0080/Gusp  
 Gut/Gutierrezia sarothrae/0079/Gut  
 Gutierrezia sarothrae/Gutierrezia sarothrae/0079/GB, Gu, Gsa, Gutsar  
 Gutierrezia sphaerocephala/Gutierrezia sphaerocephala/0080/GsB  
 Gutierrezia/Gutierrezia sarothrae/0079/GB, Gu, z  
 Gutsar/Gutierrezia sarothrae/0079/Gutsar  
 H/H(unknown)/0155/H  
 Hairy Caltrop/Kallstroemia hirsutissima/0089/Kalhir

Hairy Kaltrop/*Kallstroemia hirsutissima*/0089/Kalhir  
Halls panicum/*Panicum hallii*/0111/Pha  
Hc/*Nama hispidum*/0107/Hc  
Hde/*Hoffmanseggia glauca*/0084/Hde  
Hdi/*Hoffmanseggia glauca*/0084/Hdi  
Hdo/*Hoffmanseggia* spp./0009/Hdo  
He/*Hoffmanseggia* spp./0010/He  
Heath Aster/*Leucelene ericoides*/0097/Ah,He  
Heliotropium/*Heliotropium* sp./0081/Ht  
Hilaria/*Hilaria mutica*/0082/H  
Hilaria mutica/*Hilaria mutica*/0082/H,Hmu  
Himu/*Hilaria mutica*/0082/Himu  
Hja/*Caesalpinia jamesii*/0049/Hja  
Hmu/*Hilaria mutica*/0082/Hmu  
Ho/*Caesalpinia jamesii*/0049/Ho  
Hode/*Hoffmanseggia glauca*/0084/Hode  
Hofden/*Hoffmanseggia glauca*/0084/Hofden  
Hoffmanseggia densiflora/*Hoffmanseggia glauca*/0084/Hd  
Hoffmanseggia drepanocarpa/*Hoffmanseggia drepanocarpa*/0083/Hr  
Hoffmanseggia jamesii/*Caesalpinia jamesii*/0049/Hj, Ho  
Hoffmanseggia sp./*Hoffmanseggia* sp./0009/Ho  
Hoffmanseggia/*Caesalpinia jamesii*/0049/Ho,Hd,H  
HofJam/*Caesalpinia jamesii*/0049/HofJam  
Honey mesquite/*Prosopis glandulosa*/0125/Projul  
Houstonia/*Houstonia* sp./0085/Hu  
Houstonia humifusa/*Houstonia humifusa*/0156/Hh  
Hpe/*Helianthus petiolaris*/0172/Hpe,HelPet  
Hro/*Hymenopappus flavescens*/0086/Hro  
Hymenopappus robustus/*Hymenopappus flavescens*/0086/Hy, Ho, Hro, Hr  
Hymenopappus/*Hymenopappus* sp./0087/Hy  
Hy/*Hymenopappus* sp./0087/Hy  
Hymenoxus/*Hymenoxys* sp./0205/H  
Hymenoxys-Rubberbush/*Hymenoxys odorata*/0206/H  
Hyro/*Hymenopappus flavescens*/0086/Hyro  
Indian Rushpea/*Hoffmanseggia glauca*/0084/Hofden  
Indian Wheat/*Plantago major*/0121/Iw  
Immature weed/!forb/0000/x  
Ipomaea/*Ipomea* sp./0197/I  
Ipomea/*Ipomea* sp./0197/Ih  
Ipomoea costellata/*Ipomoea costellata*/0157/Ic  
Ironplant Goldenweed/*Machaeranthera pinnatifida*/0190/Aplspi  
is it fluff grass/*Dasyochloa pulchella*/0061/tpu

Iva/Iva sp./0207/I  
 Iva dealbata/Iva dealbata/0210/Iv  
 James Hoffmansseggia/Caesalpinia jamesii/0049/Ho  
 Kallstroemia/Kallstroemia sp./0193/K  
 Kallstroemia grandiflora/Kallstroemia grandiflora/0088/Kg  
 Kallstroemia hisut/Kallstroemia hirsutissima/0089/Kh  
 Kallstyaemia hirsutissima/Kallstroemia hirsutissima/0089/Kh  
 Khi/Kallstroemia hirsutissima/0089/Khi,Xa  
 knot weed/Euphorbia albomarginata/0069/Kn  
 Krameria/Krameria sp./0091/Kr  
 Krameria secundiflora/Krameria secundiflora/0158/Ks  
 La/Linum australe/0098/La,Ls,Lau  
 Lamb's Quarter/Chenopodium sp./0183/Lq  
 Large annual grama/Bouteloua sp./0048/Ga  
 Larrea tridentata/Larrea tridentata/0092/CB  
 Lau/Linum australe/0098/Lau  
 Lavauxia primaveris/Lavauxia primaveris/0093/Lpr  
 Le/Croton pottsii/0054/Le  
 Leather croton/Croton pottsii/0054/Crocon,Crocro,Crocor  
 Leather weed/Croton pottsii/0054/Le  
 Lefe/Lesquerella fendleri/0094/Lefe  
 Lemonweed/Pectis papposa/0116/PecPap  
 Lesfen/Lesquerella fendleri/0094/Lesfen  
 Lesquerella fendleri/Lesquerella fendleri/0094/Lu,Lf,Lfe  
 Lesquerella purpurea/Lesquerella purpurea/0095/Lu  
 Lesquerella/Lesquerella sp./0096/Lu,Liu,Lf  
 Le weed/Lesquerella sp./0096/Le  
 Lfe/Lesquerella fendleri/0094/Lfe  
 Liau/Linum australe/0098/Liau  
 Lin/Linum australe/0098/Lin,Lau  
 Linaus/Linum australe/0098/Linaus  
 Linum australe/Linum australe/0098/La,Ls,Lau  
 Linum//Linum australe/0098/L,La  
 Lo/Astragalus sp./0037/Lo  
 Loco/Astragalus sp./0037/Lo  
 low parsolea/Dalea nana/0059/Lp  
 low Tridens/Dasyochloa pulchella/0061/Tr,Tp,Lt,L  
 Lpr/Lavauxia primaveris/0093/Lpr  
 Ls/Linum australe/0098/Ls  
 Lu/Lu(unknown)/0169/Lu  
 Maau/Machaeranthera pinnatifida/0190/Maau

Mal/Mentzelia albicaulis/0194/Mal  
Mallow/Sphaeralcea subhastata/0134/Ma,Mg,MI  
Malopodium lecantheum/Melampodium leucanthum/0100/Mle  
Mar/Muhlenbergia arenicola/0181/Mar  
Mau/Muhlenbergia arenacae/0103/Mau  
Meal/Mentzelia albicaulis/0194/Meal  
Melampodium leucanthum/Melampodium leucanthum/0100/Mle  
Mentzelia multiflora/Mentzelia pumila/0101/Me,Mm,Mmu  
Mentzelia/Mentzelia pumila/0101/Mm,Me  
Mentzolia albicaulis/Mentzelia albicaulis/0194/M  
mesa dropseed/Sporobolus flexuosus/0138/Sf,S,Sfl  
mesquite gr./Panicum obtusum/0113/Me  
mesquite grass/Panicum obtusum/0113/Me  
mesquite/Prosopis glandulosa/0125/PB,M,Me,Pju  
Mg/Sphaeralcea subhastata/0134/Mg  
Milkweed/Asclepias sp./0199/Mw  
Mle/Melampodium leucanthum/0100/Mle  
Mmu/Mentzelia pumila/0101/Mmu  
Mn/Munroa squarrosa/0106/Mn  
Moc/Schrankia occidentalis/0012/Moc  
Mollugo/Mollugo sp./0196/Mol  
Mollugo cerviana/Mollugo cerviana/0102/Mc,X8,Mx  
Morongia ácuán sp./Schrankia occidentalis/0011/Mo  
Morongia occ/Schrankia occidentalis/0012/Mo  
Morongia occidentalis/Schrankia occidentalis/0012/Mo  
Morongia/Schrankia occidentalis/0012/Mo,Moc  
Mouse ear/Tidestromia lanuginosa/0141/Mr,Tidlan,Mn,Mo  
Ms/Munroa squarrosa/0106/Ms  
Msq/Prosopis glandulosa/0125/Msq  
Mu/Munroa squarrosa/0106/Msq,Mu  
Muhlenbergia/Muhlenbergia arenicola/0181/Mar  
Muhlenbergia arenicola/Muhlenbergia arenicola/0181/Ma,Mar  
Muhlenbergia porteri/Muhlenbergia porteri/0104/Mp  
Muhly arenicola/Muhlenbergia arenicola/0181/Ma  
Munroa squarrossa/Munroa squarrosa/0106/Mn,Ms,Mu  
Munroa/Munroa sp./0105/Mn,Mu  
Na>Nama sp./0108/X,Na  
Nahi>Nama hispidum/0107/Nahi  
Nam>Nama sp./0108/Nam  
Namhis>Nama hispidum/0107/Namhis  
Narrow-leaf Eriogonum/Eriogonum sp./0068/En  
Navajo Grass/Sorghastrum rutans/0173/Nj

Needle grass/*Aristida* sp./0033/A  
 Opu/*Opuntia* sp./0187/Opu  
 Opuntia/*Opuntia* sp./0187/OB  
 Orange centered yellow composite/*Gaillardia* sp./0077/Oc  
 Orange Creeper/*Kallstroemia hirsutissima*/0089/Oc  
 Orange Eriogonum/*Eriogonum abertianum*/0064/Eriabe,Eo  
 Othake/*Palafoxia sphacelata*/0013/Ok,OthSph  
 Othake orabanche/*Palafoxia* sp./0201/Oor  
 Othake *Sphacelatum*/*Palafoxia sphacelata*/0013/Ok  
 P/*Panicum hallii*/0111/P  
 Pab/*Panicum obtusum*/0113/Pab,Paob  
 Pan/*Panicum* sp./0114/Pan  
 Panic grass/*Panicum* sp./0114/Pa  
 Panicle/*Sporobolus* sp./0139/P  
 Panicked/*Sporobolus* sp./0139/P  
 Panicked grass/*Sporobolus* sp./0139/P  
 Panicked seedling/*Sporobolus* sp./0139/Psd,P,Apa  
 Panicum barbi/*Panicum capillare*/0184/Pa  
 Panicum barbipuluinatum/*Panicum capillare*/0184/Pa  
 Panicum hallii/*Panicum hallii*/0111/Apa,P,Pa,Pb,Ph,Pha,Phi  
 Panicum hirticaule/*Panicum hirticaule*/0112/Pi  
 Panicum obtusum/*Panicum obtusum*/0113/Apa,Pa,Pv,P,Po,Pob,g  
 Panicum/*Panicum* sp./0114/Pa,P,Apa  
 Pappophorum/*Enneapogon desvauxii*/0063/Pap  
 Pappophorum wrightii/*Enneapogon desvauxii*/0063/Pap  
 Par/*Dalea* sp./0060/Par  
 Paresela/*Dalea* sp./0060/Pr.  
 Parosela jonesii/*Dalea jamesii*/0058/Pr  
 Parosela nana/*Dalea nana*/0059/Pr,Pn,X5,Pna  
 Parosela/*Dalea* sp./0060/Pr.  
 Parry Euphorbia/*Euphorbia parryi*/0072/Euppar  
 Parry's Euphorbia/*Euphorbia parryi*/0072/Euppar  
 Paspalum/*Paspalum setaceum*/0159/Pas  
 Pea-like seedling/!forb/0000/y  
 Pepa/*Pectis papposa*/0116/Pepa  
 Pecpap/*Pectis papposa*/0116/O,Pecpap  
 Pectis angustifolia/*Pectis angustifolia*/0115/Pg,Pc  
 Pectis glandulosa/*Pectis* sp./0117/Pgl  
 Pectis papposa/*Pectis papposa*/0116/Pecpap  
 Pectis/*Pectis* sp./0117/Pg,Pecpap,Pe  
 Perezia/*Perezia* sp./0166/Pe

Perezia nana/Perezia nana/0188/Pe,Pna,Pz,x  
Petalostemon compactus/Petalostemon compactum/0119/Ph  
Pgl(1) (point)/Pectis sp./0117/Pgl  
Pgl(2) (contour)/Prosopis glandulosa/0125/Pju  
Pgr/Panicum sp./0114/Pgr  
Pha/Panicum hallii/0111/Pha  
Phi/Panicum hirticaule/0112/z,Phi  
Phlox/Gilia pumila/0078/Ph  
pigweed/Amaranthus retroflexus/0022/Amaret,O  
Pin/Phacelia sp./0189/Pin  
Pju/Prosopis glandulosa/0125/Pju  
Plantago/Plantago patagonica/0122/Pl  
Plantago purshii/Plantago purshii/0160/X7,Po  
Plantain/Plantago patagonica/0122/Pl  
Pna/Perezia nana/0188/Pna  
Pne/Phacelia neomexicana/0120/Pne  
Pob/Panicum obtusum/0113/Pob  
Poinsettia dentata/Euphorbia dentata/0070/Pd  
Por/Portulaca sp./0124/Por  
Porole/Portulaca oleracea/0123/Porole  
Porpil/Portulaca sp./0124/Porpil  
Porter's muhlenbergia/Muhlenbergia porteri/0104/Mp  
Portulaca oleracea/Portulaca oleracea/0123/Ot  
Portulaca pilosa/Portulaca sp./0124/Pu,Io,Ppi,X3  
Portulaca/Portulaca sp./0124/Pu,Por  
possibly unknown!/forb/0000/Un  
Ppa/Pectis papposa/0116/Ppa  
Ppi/Portulaca sp./0124/Ppi,X1  
Pr/Solanum elaeagnifolium/0130/Pr  
Pra/Aphanostephus ramosissimus/0015/Pra  
Prairie sunflower/Helianthus petiolaris/0172/HelPet  
Prairie zinnia/Zinnia grandiflora/0147/Pz,Zp  
Primrose/Onagraceae/0204/Pr  
Prju/Prosopis glandulosa/0125/Prju  
Prosopis glandulosa/Prosopis glandulosa/0125/PB,Pgl  
Prosopis/Prosopis glandulosa/0125/PB  
Psilostrophe langinosa/Psilostrophe sp./0185/Tx  
Psilostrophe tagetinae/Psilostrophe tagetina/0126/Pt,Tx,Pta  
Psilostrophe/Psilostrophe tagetina/0126/Pt,Pta  
Psitag/Psilostrophe tagetina/0126/Psitag  
Pt/Psilostrophe tagetina/0126/Pt  
Pta/Psilostrophe tagetina/0126/Pta

Pu/Portulaca sp./0124/Pu  
 Purple creeper/Allionia incarnata/0021/Pc, Allinc  
 Purple flower>Nama hispidum/0107/Pr, Pf  
 Purple pea/Purple pea(unknown)/0165/Pp  
 Purple ped/Purple ped(unknown)/0016/pp  
 Purple prickle/Solanum elaeagnifolium/0130/Pr  
 Purple roll-leaf>Nama hispidum/0107/Pf, Namhis, Chi  
 Purple scorpion weed/Phacelia sp./0189/Ps  
 Purple zinnia/Zinnia grandiflora/0147/Pz  
 Pursley/Portulaca sp./0124/Pu, Porpil, Porde, Porale, O  
 Pwi/Dithyrea wislizenii/0017/Pwi  
 Rabbit bush/Gutierrezia sarothrae/0079/Rb  
 Rb/Gutierrezia sarothrae/0079/Rb  
 red eye/Gaillardia sp./0077/Re  
 red three awn/Aristida sp./0033/A, Alo  
 Redroot/Amaranthus retroflexus/0022/Amaret  
 resin weed/Larrea tridentata/0092/Re  
 Ring Mga/Muhlenbergia torreyi/0180/R  
 Ring Muhl'bgia/Muhlenbergia torreyi/0180/R  
 Ring Muhlenbergia/Muhlenbergia torreyi/0180/R  
 Roll leaf>Nama hispidum/0107/Pf  
 Roughstalk witchgrass/Panicum hirticaule/0112/Phi  
 R-T/Salsola australis/0127/R-T  
 Rubber bush/Gutierrezia sarothrae/0079/Rb  
 Russian thistle/Salsola australis/0127/Salkal, Casbau, O  
 Russian tumbleweed/Salsola australis/0127/Salkal  
 S. airoides/Sporobolus airoides/0135/Sai, Ss  
 S. auriculatus/Muhlenbergia arenacea/0103/S, Sd, Sau  
 S. crypt. flex./Sporobolus sp./0139/S, O  
 S. flexuosus/Sporobolus flexuosus/0138/S  
 Sacaton/Sporobolus airoides/0135/S  
 Sacatone/Sporobolus airoides/0135/S  
 sagebrush/Artemisia spp./0035/ArB  
 Sai/Sporobolus airoides/0135/Sai  
 Saka/Salsola australis/0127/Saka  
 Sakat/Salsola australis/0127/Sakat  
 Salkai/Salsola australis/0127/Salkai  
 Salkal/Salsola australis/0127/Salkal  
 Salsola kali/Salsola australis/0127/Salkal  
 Salsula/Salsola sp./0195/Salsula  
 sand dropseed/Sporobolus cryptandrus/0137/Sf, S

sand muhly/Muhlenbergia arenicola/0181/Mar  
sand sagebrush/Artemisia filifolia/0034/ArB  
sand sedge/Cyperus uniflorus/0057/Se,Sd  
Sanne/Cassia bauhinioides/0050/Casbau  
Sar/Muhlenbergia arenacea/0103/Sar  
sasafrass composite/Bahia absinthifolia/0039/Sa  
sasafrass weed/Bahia absinthifolia/0039/Sa  
sasafrass/Bahia absinthifolia/0039/Sa  
Sau/Muhlenbergia arenacea/0103/S,Sau  
Sbr/Scleropogon brevifolius/0129/Sbr  
Scbr/Scleropogon brevifolius/0129/Scbr  
Schranksia occidentalis/Schranksia occidentalis/0128/Schocc  
Schranksia/Schranksia occidentalis/0128/D,Schocc  
Scleropogon/Scleropogon brevifolius/0129/Sb,O  
Scleropogon brevifolius/Scleropogon brevifolius/0129/Sb,Sbr,O  
Sco/Sporobolus contractus/0136/Sco  
sedge/Cyperus sp./0056/Se,S  
seedling/!grass/0001/A,As,y,x,G,n,S,sds  
Sel/Solanum elaeagnifolium/0130/Sel  
Selanocarpus/Ammocodon chenopodioides/0200/Sc  
Selinocarpus/Ammocodon chenopodioides/0200/Sc  
Selinocarpus chenopodioides/Ammocodon chenopodioides/0200/Sc,Se  
Sema/Setaria marostachya/0018/Sema  
Senecio/Senecio sp./0167/Se  
Senna/Cassia bauhinioides/0050/Casbau  
sensitive brier/Schranksia occidentalis/0012/Se,Shrocc  
Setaria sp./Setaria sp./0175/Set  
Sf seedling/Sporobolus flexuosus/0138/Sf  
Sfl/Sporobolus flexuosus/0138/Sfl,x  
shadscale/Atriplex canescens/0038/AB  
Sid/Aplopappus sp./0027/Sid  
Sideranthus/Aplopappus sp./0027/Si,Sid  
Sil. nightshade/Solanum elaeagnifolium/0130/Sn  
Silver nightshade/Solanum elaeagnifolium/0130/Solela,Sn  
Silverleaf nightshade/Solanum elaeagnifolium/0130/Solela  
Silvery nightshade/Solanum elaeagnifolium/0130/Sn  
Sin/Sphaeralcea incana/0132/Sin  
six weeks grass(1)/Aristida adscensionis/0028/Aad  
six weeks grass(2)/Bouteloua barbata/0045/Bba  
six weeks grass(3)/!grass/0001/Sx  
six-weeks aristida/Aristida adscensionis/0028/Aad  
six-weeks grama/Bouteloua barbata/0045/Bba,Sx,x,Sg

six-weeks threeawn/*Aristida adscensionis*/0028/Aad,y,Ada  
 Sja/*Solanum jamesii*/0131/Sja  
 Ska/*Salsola australis*/0127/Ska  
 small loco/*Astragalus* sp./0037/Lo  
 small purple sandbur/*Krameria lanceolata*/0090/Ps  
 small rosette!/forb/0000/Un  
 small weed annual!/forb/0000/An,As  
 snakebush/*Gutierrezia sarothrae*/0079/Rw  
 snakeweed/*Gutierrezia sarothrae*/0079/GB,Rb,Gutsar,Gsa  
 soaptree yucca/*Yucca elata*/0146/YB,Yucela  
 soapweed/*Yucca elata*/0146/Sw  
 Soc/*Schrankia occidentalis*/0128/Soc  
 Soel/*Solanum elaeagnifolium*/0130/Soel  
 Solanum elaeag/*Solanum elaeagnifolium*/0130/Se  
 Solanum elaeagnifolium/*Solanum elaeagnifolium*/0130/Se,Sn,Sel  
 Solanum/*Solanum elaeagnifolium*/0130/Se  
 Solela/*Solanum elaeagnifolium*/0130/Solela  
 Spco/*Sporobolus contractus*/0136/Spco  
 SpCoc/*Sphaeralcea coccinea*/0177/SpCoc  
 SpCoe/*Sphaeralcea coccinea*/0177/SpCoe  
 Spe/*Salsola australis*/0127/Spe  
 Spéctacle Pod/*Dithyrea wislizenii*/0062/Sp,DitWiz  
 Spfl/*Sporobolus flexuosus*/0138/Spfl  
 Sphaeralcea/*Sphaeralcea* sp./0133/Sh  
 Sphaeralcea coccinea/*Sphaeralcea coccinea*/0177/Spcc  
 Sphaeralcea elata/*Sphaeralcea coccinea*/0177/Sp  
 Sphaeralcea subhastata/*Sphaeralcea subhastata*/0134/Sh,Mal  
 Sph/*Sphaeralcea* sp./0133/Sph  
 spiderling/*Boerhaavia spicata*/0042/Boetor  
 spike dropseed/*Sporobolus contractus*/0136/S  
 spike loco/*Astragalus* sp./0037/S  
 Spin/*Sphaeralcea incana*/0132/Spin  
 Spiny sideanthus/*Aplopappus* sp./0027/Si,Au,Spin  
 Sporobolus aeroides/*Sporobolus airoides*/0135/Sai,Ss  
 Sporobolus airoides/*Sporobolus airoides*/0135/Sai,Ss,Sa,S  
 Sporobolus auric/*Muhlenbergia arenacea*/0103/Sau  
 Sporobolus auriculatus/*Muhlenbergia arenacea*/0103/S,Sd,Sau  
 Sporobolus contractus/*Sporobolus contractus*/0136/S,Sx,Sco  
 Sporobolus cryptandrus/*Sporobolus cryptandrus*/0137/S  
 Sporobolus crypt-flex/*Sporobolus* sp./0139/S  
 Sporobolus flexuosus/*Sporobolus flexuosus*/0138/Sf,S,Scl,Sfl

Sporobolus flex/Sporobolus flexuosus/0138/S  
Sporobolus seedling/Sporobolus sp./0139/Sy,S,Spo  
Sporobolus/Sporobolus sp./0139/S,Sy,Sf  
Spsu/Sphaeralcea subhastata/0134/Spsu  
spurge/Euphorbia albomarginata/0069/Sr,Sp  
Sqel/Solanum elaeagnifolium/0019/Sqel  
Ssu/Sphaeralcea subhastata/0134/Ssu  
Stink weed/Tetraclea coulteri/0140/St  
Sunflower/Helianthus petiolaris/0172/Helcan  
Tal/Talinum sp./0202/Tal  
Talinum/Talinum sp./0202/Ta  
Tall eriogonum/Eriogonum annuum/0065/Ta,Er,Te  
Tall white Eriog/Eriogonum annuum/0065/Etw  
Tall white eriogonium/Eriogonum annuum/0065/Ew,Er,Ewt,Etw  
Tco/Tetraclea coulteri/0140/Tco  
Tetraclea/Tetraclea sp./0161/#Tetraclea,Te  
Tetraclea angustifolia/Tetraclea coulteri/0140/Te  
Tetraclea coulteri/Tetraclea coulteri/0140/Tc  
three awn/Aristida sp./0033/A,Ap,Alo  
three awn(red)/Aristida sp./0033/Alo  
Tickseed/Corispermum nitidum/0052/Cornit  
Tickweed/Corispermum nitidum/0052/O,Cornit,Tick  
Tidestroemia lanuginosa/Tidestroemia lanuginosa/0141/Td,Tla  
Tidestroemia/Tidestroemia lanuginosa/0141/Td,Tm  
Tidlan/Tidestroemia lanuginosa/0141/Tidlan  
Tla/Tidestroemia lanuginosa/0141/Tla  
Tobosa/Hilaria mutica/0082/Hmu,To  
tobosa grass/Hilaria mutica/0082/H,To  
Townsendia/Townsendia sp./0142/Ts  
Townsendia fendleri/Townsendia sp./0142/Tf,Ts  
Tpu/Dasyochloa pulchella/0061/Tpu  
Tr/Dasyochloa pulchella/0061/Tr  
Trailing allionia/Allaturia incarnata/0020/Allinc  
Trelease/Aphanostephus ramosissimus/0024/Tr  
Tribulus terrestris/Tribulus terrestris/0143/Tt  
Tridens pulchellus/Dasyochloa pulchella/0061/Tou  
Triple Flower/Allionia incarnata/0163/Tf  
Triodea pulchella/Dasyochloa pulchella/0061/Tp,Tpu  
Triodea/Dasyochloa pulchella/0061/Tp,Tr  
Triodia/Dasyochloa pulchella/0061/Lt  
Triodia pulchellus/Dasyochloa pulchella/0061/Tr  
Tte/Tribulus terrestris/0143/Tte

Ttr/Ttr(unknown)/0178/Ttr  
 tumbling russian thistle/*Salsola australis*/0127/Salkal  
 Twin Leaf/*Cassia bauhinioides*/0050/T,Tw,CasBau  
 Twin Leaves/*Cassia bauhinioides*/0050/T,Tw,Cba  
 Umbelliferae/*Apiaceae*/0026/Um  
 Unkn!/forb/0000/A  
 unknown!/forb/0000/Un,U,X,l,Ukn,Ukw,Z,A  
 unknown annual!/forb/0000/X  
 unknown annual weed!/forb/0000/Un,X,Wa  
 unknown grass!/grass/0001/Ung  
 unknown grass seedling!/grass/0001/An,Gun,Unk,x,Un  
 unknown plant!/forb/0000/y  
 unknown seedling!/grass/0001/X  
 unknown weed!/forb/0000/W,Uwd,X,Z,Un,Unw,Unk  
 Verbena/*Verbena* sp./0208/X-11  
 Verbena *ambrosiaefolia*/*Verbena ambrosifolia*/0209/Ve  
 Vetch/Vetch/0144/V  
 vine mesquite/*Panicum obtusum*/0113/Pob  
 vine mesquite grass/*Panicum obtusum*/0113/g,Mv  
 Wedeliella/*Allionia incarnata*/0021/Wl  
 Wedeliella incarnate/*Allionia incarnata*/0021/Wl,Pc  
 weed!/forb/0000/BL,z,Wn,Weed  
 Weed like rubber plant/*Euphorbia* sp./150/W  
 White burrograss/*Scleropogon brevifolius*/0129/Bw  
 White crucifer/*Abronia fragrans*/0162/Wh  
 White daisy/*Melampodium leucanthum*/0100/Wd  
 White Eriogonum/*Eriogonum annuum*/0065/Ew,We  
 White leaf typh/*Euphorbia albomarginata*/0069/Eupalb  
 White margin Euphorbia/*Euphorbia albomarginata*/0069/Eupalb  
 White stem/*Mentzelia pumila*/0101/Ws,Wh,Nu  
 Win/*Allionia incarnata*/0021/Win  
 Wing Seed/*Atriplex canescens*/0038/Wi  
 Winged Seed/*Atriplex canescens*/0038/Wi  
 Wl/*Allionia incarnata*/0021/Wl  
 Woolly loco/*Astragalus mollissimus*/0198/Wl  
 Woolly tidestroemia/*Tidestroemia lanuginosa*/0141/Tidlow  
 Woolly weed!/forb/0000/Ww  
 woolly yellow composite/*Baileya multiradiata*/0040/Wo  
 X-1!/grass/0001/X-1  
 X-2/*Oenothera albicaulis*/0109/X-2  
 X-3/*Portulaca* sp./0124/X-3

X-4/Evolvulus nuttallianus/0074/X-4  
X-5/!grass/0001/X-5  
X-11/Verbena sp./0208/X-11  
X/!grass/0001/X  
Xi/!grass/0001/Xi  
YB/Yucca elata/0146/YB  
Yel/Yucca elata/0146/Yel  
yellow bush/Psilostrophe tagetina/0126/Yb  
yellow eriogonum/Eriogonum sp./0068/Ey  
yellow gonum/Eriogonum sp./0068/Ey  
yellow flax/Linum vernale/0099/Yf,L,Yk  
Yellow sandbur/Tribulus terrestris/0143/Ys  
yellow stamen grama/Bouteloua sp./0048/Yg  
Yuba/Yucca baccata/0145/Yuba  
Yucca elata/Yucca elata/0146/YB, Yel  
yucca/Yucca elata/0146/YB, Yel, Yucela  
Yucela/Yucca elata/0146/Yel, Yucela  
Yucl/Yucca elata/0146/Yucl  
Yuel/Yucca elata/0146/Yuel  
Zg/Zinnia grandiflora/0147/Zg  
Zgl/Zinnia gradiflora/0147/Zgl  
Zgr/Zinnia grandiflora/0147/Zgr  
Zinnia grandiflora/Zinnia grandiflora/0147/Zg  
Zinnia/Zinnia grandiflora/0147/Zg

**APPENDIX D  
LATIN LIST**



ISEM Final Report, Volume I

0000/0000/!forb  
0001/0002/!grass  
0002/0003/Acacia constricta  
0003/0000/Boerhaavia spicata  
0004/0000/Cassia bauhinioides  
0005/0000/Cryptantha micrantha  
0006/0003/Condalia sp.  
0007/0000/Croton pottsii  
0008/0003/Gutierrezia sarothrae  
0009/0000/Hoffmanseggia spp.  
0010/0000/Hoffmanseggia spp.  
0011/0000/Schrankia occidentalis  
0012/0000/Schrankia occidentalis  
0013/0000/Palafoxia sphacelata  
0014/0002/Panicum sp.(unknown)  
0015/0000/Aphanostephus ramosissimus  
0016/0014/Purple ped(unknown)  
0017/0000/Dithyrea wislizenii  
0018/0001/Setaria marostachya  
0019/0000/Solanum elaeagnifolium  
0020/0000/Allaturia incarnata  
0021/0000/Allionia incarnata  
0022/0000/Amaranthus retroflexus  
0023/0000/Amsinkia sp.  
0024/0000/Aphanostephus ramosissimus  
0025/0000/Aphanostephus sp.  
0026/0000/Apiaceae  
0027/0000/Aplopappus sp.  
0028/0002/Aristida adscensionis  
0029/0011/Aristida divaricata  
0030/0011/Aristida pansa  
0031/0011/Aristida purpurea  
0032/0011/Aristida purpurea v. longesita  
0033/0011/Aristida sp.  
0034/0018/Artemisia filifolia  
0035/0018/Artemisia spp.  
0036/0000/Astragalus nuttallianus  
0037/0000/Astragalus sp.  
0038/0016/Atriplex canescens  
0039/0000/Bahia absinthifolia  
0040/0000/Baileya multiradiata

*ISEM Final Report, Volume I*

0041/0000/Boerhaavia sp.  
0042/0000/Boerhaavia spicata  
0043/0001/Bothriochloa saccharoides  
0044/0002/Bouteloua aristidoides  
0045/0002/Bouteloua barbata  
0046/0006/Bouteloua eriopoda  
0047/0002/Bouteloua parryi  
0048/0006/Bouteloua sp.  
0049/0000/Caesalpinia jamesii  
0050/0000/Cassia bauhinioides  
0051/0000/Chenopodium incanum  
0052/0000/Corispermum nitidum  
0053/0000/Croton luteovirons  
0054/0000/Croton pottsii  
0055/0000/Cryptantha crassisejala  
0056/0017/Cyperus sp.  
0057/0017/Cyperus uniflorus  
0058/0000/Dalea jamesii  
0059/0000/Dalea nana  
0060/0000/Dalea sp.  
0061/0001/Dasyochloa pulchella  
0062/0000/Dithyrea wislizenii  
0063/0001/Enneapogon desvauxii  
0064/0000/Eriogonum abertianum  
0065/0000/Eriogonum annuum  
0066/0000/Eriogonum jamseii  
0067/0000/Eriogonum rotundifolium  
0068/0000/Eriogonum sp  
0069/0000/Euphorbia albomarginata  
0070/0000/Euphorbia dentata  
0071/0000/Euphorbia neomexicana  
0072/0000/Euphorbia parryi  
0073/0000/Euploca convolvulacea  
0074/0000/Evolvulus nuttallianus  
0075/0000/Evolvulus sp.  
0076/0001/Festuca sp.  
0077/0000/Gaillardia sp.  
0078/0000/Gilia pumila  
0079/0003/Gutierrezia sarothrae  
0080/0000/Gutierrezia sphaerocephala  
0081/0000/Heliotropium sp.  
0082/0007/Hilaria mutica

*ISEM Final Report, Volume I*

0083/0000/Hoffmanseggia drepanocarpa  
0084/0000/Hoffmanseggia glauca  
0085/0000/Houstonia sp.  
0086/0000/Hymenopappus flavescens  
0087/0000/Hymenopappus sp.  
0088/0000/Kallstroemia grandiflora  
0089/0000/Kallstroemia hirsutissima  
0090/0000/Krameria lanceolata  
0091/0000/Krameria sp.  
0092/0012/Larrea tridentata  
0093/0000/Lavauxia primaveris  
0094/0000/Lesquerella fendleri  
0095/0000/Lesquerella purpurea  
0096/0000/Lesquerella sp.  
0097/0000/Leucelene ericoides  
0098/0000/Linum australe  
0099/0000/Linum vernale  
0100/0000/Melampodium leucanthum  
0101/0000/Mentzelia pumila  
0102/0000/Mollugo cerviana  
0103/0001/Muhlenbergia arenacea  
0104/0013/Muhlenbergia porteri  
0105/0002/Munroa sp.  
0106/0002/Munroa squarrosa  
0107/0000>Nama hispidum  
0108/0000>Nama sp.  
0109/0000/Oenothera albicaulis  
0110/0000/Oenothera runcinata  
0111/0001/Panicum hallii  
0112/0002/Panicum hirticaule  
0113/0008/Panicum obtusum  
0114/0001/Panicum sp.  
0115/0000/Pectis angustifolia  
0116/0000/Pectis papposa  
0117/0000/Pectis sp  
0118/0000/Penstemon sp.  
0119/0000/Petalostemon compactum  
0120/0000/Phacelia neomexicana  
0121/0000/Plantago major  
0122/0000/Plantago patagonica  
0123/0000/Portulaca oleracea

0124/0000/Portulaca sp.  
0125/0004/Prosopis glandulosa  
0126/0000/Psilostrophe tagetina  
0127/0015/Salsola australis  
0128/0000/Schrankia occidentalis  
0129/0009/Scleropogon brevifolius  
0130/0000/Solanum elaeagnifolium  
0131/0000/Solanum jamesii  
0132/0000/Sphaeralcea incana  
0133/0000/Sphaeralcea sp.  
0134/0000/Sphaeralcea subhastata  
0135/0001/Sporobolus airoides  
0136/0010/Sporobolus contractus  
0137/0010/Sporobolus cryptandrus  
0138/0010/Sporobolus flexuosus  
0139/0010/Sporobolus sp.  
0140/0000/Tetraclea coulteri  
0141/0000/Tidestromia lanuginosa  
0142/0000/Townsendia sp.  
0143/0000/Tribulus terrestris  
0144/0000/Vetch  
0145/0005/Yucca baccata  
0146/0005/Yucca elata  
0147/0000/Zinnia grandiflora  
0148/0014/BJM(unknown)  
0149/0019/cactus(unknown)  
0150/0000/Euphorbia sp.  
0151/0014/CO(unknown)  
0152/0000/Erigeron ballidiastrum  
0153/0000/Erigeron sp.  
0154/0000/Eriastrum diffusum  
0155/0014/H(unknown)  
0156/0000/Houstonia humifusa  
0157/0000/Ipomoea costellata  
0158/0000/Krameria secundiflora  
0159/0001/Paspalum setaceum  
0160/0000/Plantago purshii  
0161/0000/Tetraclea sp.  
0162/0000/Abronia fragrans  
0163/0000/Allionia incarnata  
0164/0000/Astragalus crassicaarpus  
0165/0014/Purple Pea(unknown)

0166/0000/Perezia sp.  
0167/0003/Senecio sp.  
0168/0000/Chamaesaracha sordidia  
0169/0014/Lu(unknown)  
0170/0000/Oenothera sp.  
0171/0000/Gilia sp.  
0172/0000/Helianthus petiolaris  
0173/0001/Sorghastrum rutans  
0174/0014/Brown Berries(unknown)  
0175/0001/Setaria sp.  
0176/0014/Ceon(unknown)  
0177/0000/Sphaeralea coccinea  
0178/0014/Ttr(unknown)  
0179/0000/False Phlox(unknown)  
0180/0001/Muhlenbergia torreyi  
0181/0001/Muhlenbergia arenicola  
0182/0001/Sporobolus nealleyi  
0183/0000/Chenopodium sp.  
0184/0002/Panicum capillare  
0185/0000/Psilostrophe sp.  
0186/0000/Machaeranthera gracilis  
0187/0019/Opuntia sp.  
0188/0000/Perezia nana  
0189/0000/Phacelia sp.  
0190/0000/Machaeranthera pinnatifida  
0191/0000/Gaillardia pinnatifida  
0192/0000/Chamaesaracha sp.  
0193/0000/Kallstroemia sp.  
0194/0000/Mentzelia albiculis  
0195/0015/Salsola sp.  
0196/0000/Mollugo sp.  
0197/0000/Ipomea sp.  
0198/0000/Astragalus mollissimus  
0199/0000/Asclepias sp.  
0200/0000/Ammocodon chenopodiodes  
0201/0000/Palafoxia sp.  
0202/0000/Talinum sp.  
0203/0000/Descurania pinnata  
0204/0000/Onagraceae  
0205/0000/Hymenoxys sp.  
0206/0000/Hymenoxys odorata

0207/0000/Iva sp.

0208/0000/Verbena sp.

0209/0000/Verbena ambrosifolia

0210/0000/Iva dealbata

0211/0000/Hybanthus verticillatus

**APPENDIX E  
IMAGES LIST**



0000/F/ 50/ 50/forb.1/ Generalized forb  
0001/P/ 35/ 35/p\_grass.1/ Generalized perennial grass  
0002/A/ 35/ 35/a\_grass.1/ Generalized annual grass  
0003/S/100/100/shrub.1/ Generalized half shrub  
0004/S/500/500/mesquite.1/Prosopis glanulosa (mesquite bush)  
0005/S/500/500/yucca.1/ Yucca elata,baccata (soaptree yucca)  
0006/P/ 35/ 35/gramma.1/ Bouteloua eriopoda (black grama)  
0007/P/ 35/ 35/tobosa.1/ Hilaria mutica (tobosa grass)  
0008/P/ 35/ 35/vinegras.1/Panicum obtusum (vine mesquite grass)  
0009/P/ 35/ 35/burro.1/ Scleropogon brevifolius (burro grass)  
0010/P/ 35/ 35/dropseed.1/Sporobolus contractus,flexuosus ( not airoides)  
0011/P/ 35/ 35/threeawn.1/Aristida sp. (three awn, red three awn)  
0012/S/200/200/creosote.1/Larrea tridentata (creosote bush)  
0013/S/100/100/muhly.1/ Muhlenbergia porteri (bush muhly)  
0014/F/100/100/unknown.1/ Unknown plant species  
0015/F/ 60/ 60/tumblewd.1/Salsola australis (tumbleweed)  
0016/S/ 50/ 50/saltbush.1/Atriplex canescens (4-wing saltbush)  
0017/P/100/100/graslike.1/Cyperus sp. (sedges)  
0018/S/ 35/ 35/sage.1/ Sand sagebrush  
0019/F/ 50/ 50/cactus.1/ Generalized round cactus



**APPENDIX F  
GEOPOSITIONED AUGMENTED, ANNOTATED QUADRAT DATA**













**APPENDIX G  
STATISTICAL PLOTS**



### Quads - A1\_ A2\_ A3\_

Months - 1 2 3 4 5 6 7 8 9 10 11 12

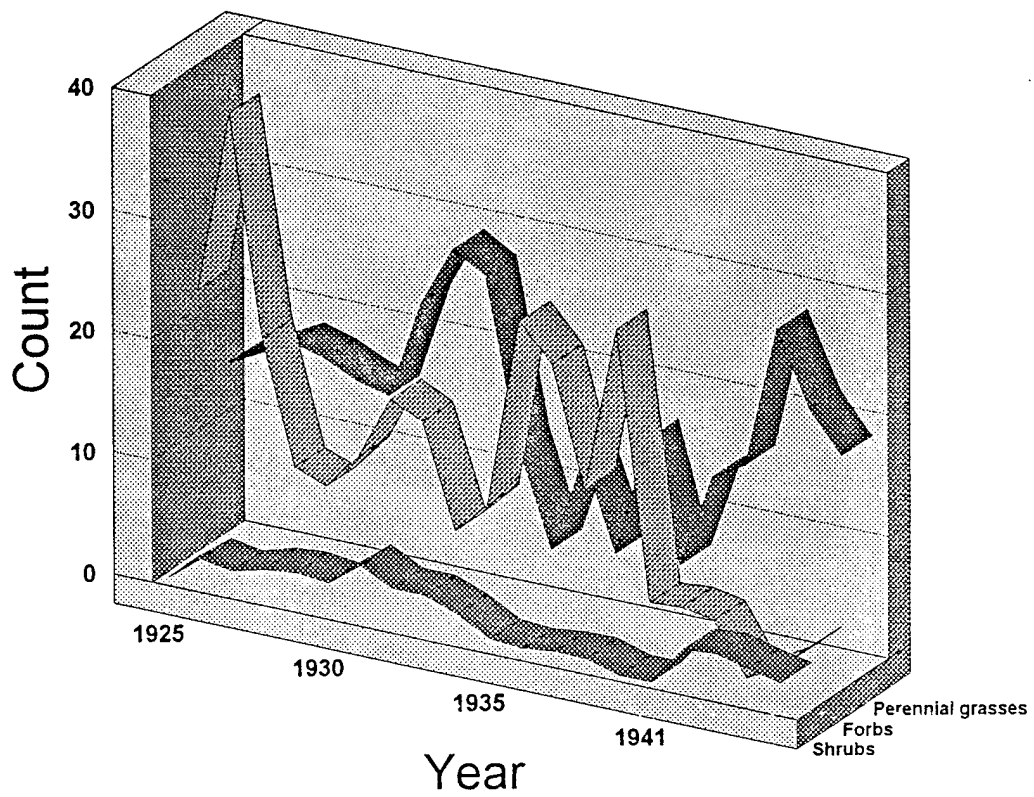

# Quads - A2\_

Months - 1 2 3 4 5 6 7 8 9 10 11 12

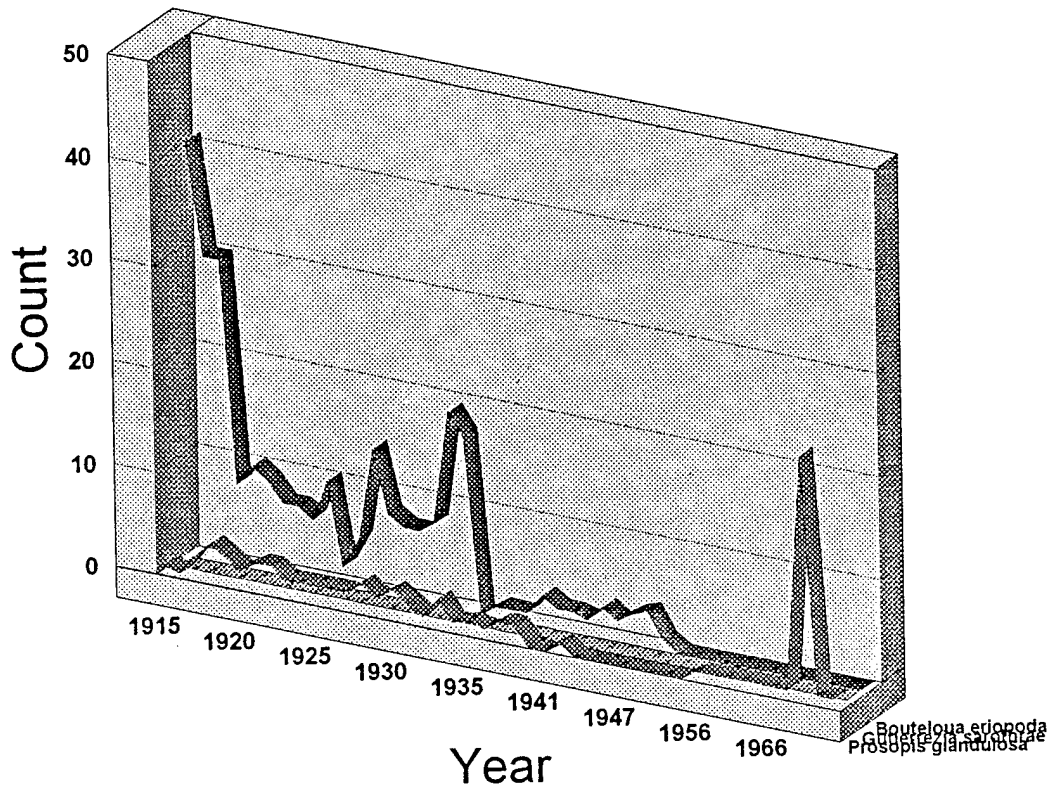

# Quads - A2\_ A3\_ A4\_ A5\_

Months - 1 2 3 4 5 6 7 8 9 10 11 12

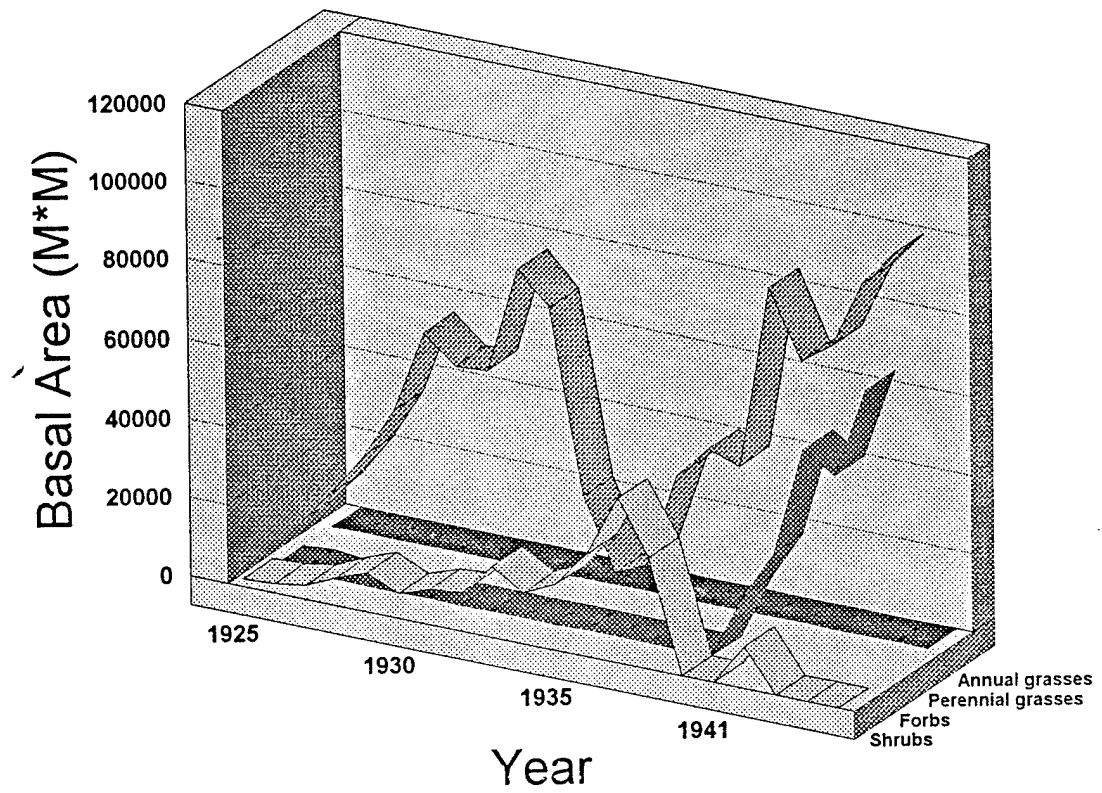



**APPENDIX H  
SOURCE CODE**



```

/*
/*   amlname:      mul_cw.aml
/*
/* This aml file creates many workspaces at the same time
/* in the current workspace
/*
/* Author: Vinh Duong, US Army Topographic Engineering Center
/*
/* Date:  28 Jun 94.

&do i &list ~ /* modify below
953ia3_0.lin 955ia3_0.lin 964ja4_0.lin 964ja5_0.lin 967ja5_0.lin ~
970ha3_0.lin 970ha4_0.lin ~
915fa1_0.lin 915ja1_0.lin 916ea1_0.lin 917fa1_0.lin 917ia1_0.lin ~
918ia1_0.lin 919ga1_0.lin 919ja1_0.lin 920ja1_0.lin 921ja1_0.lin ~
922ja1_0.lin 923ja1_0.lin 924ja1_0.lin 925ja1_0.lin 926ia1_0.lin ~
927ia1_0.lin 928ia1_0.lin 929ia1_0.lin 930ha1_0.lin 931ia1_0.lin ~
932ia1_0.lin 933ja1_0.lin 934ja1_0.lin 935ea1_0.lin 935ja1_0.lin ~
936ja1_0.lin 937ja1_0.lin 938ia1_0.lin 940aa1_0.lin 941ba1_0.lin ~
942aa1_0.lin 942ja1_0.lin 943la1_0.lin 944ia1_0.lin 945ia1_0.lin ~
947ba1_0.lin 947ia1_0.lin 949ia1_0.lin 950ka1_0.lin 951ha1_0.lin ~
952ia1_0.lin 956ha1_0.lin 957ha1_0.lin 958ia1_0.lin 959ia1_0.lin ~
960ha1_0.lin 961ia1_0.lin 965ja1_0.lin 966ja1_0.lin 968ha1_0.lin ~
969ia1_0.lin 971ga1_0.lin 972ha1_0.lin 973ha1_0.lin 974fa1_0.lin ~
975ha1_0.lin 976ga1_0.lin 977ga1_0.lin

&s worksp yr_[substr %i% 1 3]

&if [exists %worksp% -workspace] or [exists %worksp% -directory] &then
    &type %worksp% existing

&else

    &do
        CREATEWORKSPACE %worksp%
        &type Created workspace %worksp%
    &end

&end /* &do

&return

```

```
#!/bin/csh
#
# script name:  recalc_y
#
# usage:  recalc_y filename
# This script recalculates the Y values
# used for quadrat data (JER)
# check the content before executing this script.
#
# 19 Sept 94 by Vinh Duong, US Army Topographic Engineering Center

#set noglob                #prevent file expansion
set com = $0               #save command name

if ($#argv != 1) then      #check arguments
    echo "Usage: $com:t filename"    #only 1 allowed
    exit 1                    #error exit
endif

if (! -f $argv[1]) then   #check for file
    echo "$com:t :No file $argv[1]"    #a space must be between t and :
    exit 1                    #error exit
endif

#comment out the following 7 lines when using "foreach"
echo -n "Are you sure you know what this script does? (Y/N) "
set choice = $<
if ( $choice !~ ['Y','y'] ) then
    echo "not executing the command"
    exit 0
endif

set infile = $argv[1]:t
set newfile = new_lin_files/$infile
cat $argv[1] | awk -F , '{if ( NF == 2 ) { $NF = 1000 - $NF}}; OFS = "," > $newfile
echo Created $newfile
```

```

#!/usr/local/bin/gawk -f
#
# script name:  sepquad
#
# usage:  sepquad filename
#
# Nawk(Gawk) file to separate JER ARC/INFO generate-format quad data into
# polygon, point, and line generate-format files.
# used for quadrat data (JER)
#
# Author: William E. Diego, Science and Technology Corporation, for
#         US Army Topographic Engineering Center
# Date: 15 Jun 94.
#
# Modified by Vinh Duong, US Army Topographic Engineering Center
#
BEGIN {FS=","; i=1; linefile=0; pointfile=0; polyfile=0}

    {line[i]=$0; ++i}

    {if ($NF=="END") {
        if (i==2) {
            if (linefile) {
                filename=FILENAME".lin"
                print "END" > filename
                print "There are lines in coverage "FILENAME
            }
            if (pointfile) {
                filename=FILENAME".pnt"
                print "END" > filename
                print "There are points in coverage "FILENAME
            }
            if (polyfile) {
                filename=FILENAME".pol"
                print "END" > filename
                print "There are polygons in coverage "FILENAME
            }
        }
        exit
    }

    if (line[2]!=line[i-2]) {

```

```
        linefile=1
        filename=FILENAME".lin"
        for (x=1;x<i;++x) {
            print line[x] > filename
        }
    } else {
        if (i==5) {
            pointfile=1
            filename=FILENAME".pnt"
            printf("%s,%s\n",line[1],line[2]) > filename
        } else {
            if (i==6) {
                linefile=1
                filename=FILENAME".lin"
                for (x=1;x<4;++x) {
                    print line[x] > filename
                }
                print line[5] > filename
            } else {
                polyfile=1
                filename=FILENAME".pol"
                printf("%s,%s\n",line[1],"AUTO") > filename
                for (x=2;x<i;++x) {
                    print line[x] > filename
                }
            }
        }
    }

    i=1
}}
```

```

/*
/*   amlname:      mul_gener.aml
/*
/* This aml file creates many coverages (POINT, LINE, POLY) at the same time
/* Fri 24 Jun 94 by Vinh Duong
/* used for quadrat data (JER)
/*

```

```

precision double /* very important, otherwise won't get correct transformation
show precision

```

```

&s old_ws [show workspace]

```

```

/* do not separate files with the same year, i.e., all files
/* with the same year should be in the list

```

```

&do i &list ~ /* modify below about 32 files or 8 lines at the same time
915fa1_0.lin.lin 915fa1_0.lin.pnt 915fa1_0.lin.pol 915ja1_0.lin.pnt ~
915ja1_0.lin.pol 916ea1_0.lin.pnt 916ea1_0.lin.pol 917fa1_0.lin.pnt ~
917fa1_0.lin.pol 917ia1_0.lin.pnt 917ia1_0.lin.pol 918ia1_0.lin.pnt ~
918ia1_0.lin.pol 919ga1_0.lin.pnt 919ga1_0.lin.pol 919ja1_0.lin.lin ~
919ja1_0.lin.pnt 919ja1_0.lin.pol 920ja1_0.lin.lin 920ja1_0.lin.pnt ~
920ja1_0.lin.pol 921ja1_0.lin.lin 921ja1_0.lin.pnt 921ja1_0.lin.pol ~
922ja1_0.lin.lin 922ja1_0.lin.pnt 922ja1_0.lin.pol 923ja1_0.lin.pnt ~
923ja1_0.lin.pol 924ja1_0.lin.pnt 924ja1_0.lin.pol 925ja1_0.lin.lin ~
925ja1_0.lin.pnt 925ja1_0.lin.pol

```

```

&s ext [after %i% .lin.]
&s cover %ext%[before %i% .]
&s worksp yr_[substr %i% 1 3]
&s quadrat [translate [substr %i% 5 3]] /* in uppercase now

```

```

&type %cover%
&type %ext%
&type %worksp%

```

```

&if [exists %worksp% -workspace] &then
&do
&workspace %worksp% /* change to the applicable workspace
&if [exists %cover% -workspace] or [exists %cover% -directory] &then
&do

```

```
&type %cover% existing. Double-check %cover%
&workspace %old_ws%
&end
&else
&if [exists temp_cover -workspace] or [exists temp_cover -directory] &then
&do
&type temp_cover existing. Double-check temp_cover
&workspace %old_ws%
&end
&else
&if [exists temp_cover2 -workspace] or [exists temp_cover2 -directory] &then
&do
&type temp_cover2 existing. Double-check temp_cover2
&workspace %old_ws%
&end
&else
&do
&if %ext% = pol &then
&set type POLYS -
&else
&if %ext% = pnt &then
&set type POINTS
&else
&set type LINES

&call gener

/* must need temp_cover here
PROJECT COVER %cover% temp_cover ../projectdef_utm.prj NEAREST

&if %quadrat% = A1_ &then
&do
&s xmax 326229.2 /* based on quadrat A1
&s ymax 3609501
&end
&else
&if %quadrat% = A2_ &then
&do
&s xmax 325753.5 /* based on quadrat A2
&s ymax 3610311
&end
&else
```

```
&if %quadrat% = A3_ &then
  &do
    &s xmax 325343.9
    &s ymax 3610969
  &end
&else
&if %quadrat% = A4_ &then
  &do
    &s xmax 324942.7
    &s ymax 3611626
  &end
&else
&if %quadrat% = A5_ &then
  &do
    &s xmax 324664.7
    &s ymax 3612320
  &end
&else
&if %quadrat% = AR4 &then
  &do
    &s xmax 327182.5
    &s ymax 3609533
  &end
&else
&if %quadrat% = AR5 &then
  &do
    &s xmax 327354.6
    &s ymax 3609793
  &end
&else
&if %quadrat% = AR6 &then
  &do
    &s xmax 327353.3
    &s ymax 3609804
  &end
&else
&if %quadrat% = B1_ &then
  &do
    &s xmax 327221.4
    &s ymax 3608284
  &end
```

```
&else
&if %quadrat% = B2_ &then
  &do
    &s xmax 327774.2
    &s ymax 3607772
  &end
&else
&if %quadrat% = B3_ &then
  &do
    &s xmax 328343.0
    &s ymax 3607260
  &end
&else
&if %quadrat% = B4_ &then
  &do
    &s xmax 328923.9
    &s ymax 3606764
  &end
&else /* quadrat B5_
  &do
    &s xmax 329498.6
    &s ymax 3606247
  &end
```

```
&s xmin %xmax% - 1
&s ymin %ymax% - 1
```

```
GENERATE temp_cover2
```

```
TICS
```

```
1,%xmax%,%ymax% /* TIC ID's must match those of %cover%
2,%xmax%,%ymin%
3,%xmin%,%ymin%
4,%xmin%,%ymax%
```

```
END
```

```
QUIT
```

```
/* before using TRANSFORM, we should have an output coverage
/* containing only the projected tics.
```

```
/* see page 5-11 of Map Projection & Coordinate Management
```

```
TRANSFORM temp_cover temp_cover2 AFFINE
```

```

/* this section of code needed to create info file .pat or.aat
&if %ext% = pol &then
  CLEAN temp_cover2 temp_cover2 # # POLY
&else
  &if %ext% = pnt &then
    BUILD temp_cover2 POINT
  &else
    CLEAN temp_cover2 temp_cover2 # # LINE

&if [exists temp_cover2 -poly] or [exists temp_cover2 -point] &then
  &s suffix PAT
&else
  &s suffix AAT
&s infofile [translate [entryname temp_cover2]].%suffix%
&s covername [translate [entryname temp_cover2]]
ADDITEM %infile% %infile% PLANT-CODE 4 5 B /* modify here

/* note: no need to change %covername%-ID
&data ARC INFO
  ARC
  SELECT %infile%
  CALCULATE PLANT-CODE = %covername%-ID /* modify here
  Q STOP
&end

PROJECTDEFINE COVER temp_cover2
projection utm
units meters
zone 13
datum nad27
parameters

KILL (! %cover% temp_cover !) ALL

RENAME temp_cover2 %cover%
&type temp_cover2 was renamed to %cover%

&end /* &do
&workspace %old_ws%
&end /* &do

```

```
&else  
  &type Workspace %worksp% not yet created. %cover% cannot be generated.
```

```
&end /* &do
```

```
&return
```

```
&routine gener  
&type %type%
```

```
  GENERATE %cover%  
  TICS  
  1,1000,1000 /* modify here if necessary  
  2,1000,0  
  3,0,0  
  4,0,1000  
  END  
  INPUT ../sepquad_files/%i% /* modify here  
  %type%  
  QUIT
```

```
&return
```

```
/*  
/*  amlname:      define.aml  
/*  
&data ARC INFO  
  ARC  
DEFINE PLANT_CODE.LUT  
PLANT-CODE,4,4,I  
PLANT-DESC,40,40,C  
  
ADD PLANT-CODE,PLANT-DESC FROM /JORNADA/VEG/QUADRAT/QUAD_PSL  
  Q STOP  
&end
```

```
/*
/*  amlname:      addrelate.aml
/*
&data ARC
  RELATE ADD
  PLANTREL
  ../INFO!ARC!PLANT_CODE.LUT
  INFO
  PLANT-CODE
  PLANT-CODE
  ORDERED
  RW

  RELATE SAVE ../INFO!ARC!RELATIONS /* RELATIONS is an info file
  QUIT
&end
```

```

#!/usr/local/bin/gawk -f
#
#
# script name:  precip_redist
#
# Nawk(Gawk) file to get the JER precip data files
# into ARC/INFO format
#
# check the content before executing this script.
#
# Date:  14 Sep. 94.
#
# by Vinh Duong, US Army Topographic Engineering Center
#
BEGIN {i=1; yr = 1915;filename="temp"} # modify filename

    {line[i]=$0
      if (i>4) {
        if (NF!=16) { print "# of fields not correct (record "NR" yr "$1" ), check file "FILE-
NAME"\n"}
        if (($1 - yr) < 0) { print "year not ordered (record "NR" yr "$1" ), check file "FILE-
NAME"\n"}
        for (j = 0; j < $1 - yr; j++)
        {
          printf("%s",",,") >> filename
        }
        yr = $1 + 1
        if (i != 5) printf(",") >> filename # ready for another field
        printf("%s,%s",$15,$16) >> filename
        if (index($1,"1993"))
        { printf("\n") >> filename
          exit 0}
        }
      ++i}

```

```
/*
/*   amlname:      add_precip.aml
/*
&data ARC INFO
  ARC
  SELECT GAGE_15_24.DAT
  ADD
  YR_915,JAS_915,YR_916,JAS_916,YR_917,JAS_917,YR_918,JAS_918,YR_919,JAS_919,Y
  R_920,JAS_920,YR_921,JAS_921,YR_922,JAS_922,YR_923,JAS_923,YR_924,JAS_924
  FROM /jornada/precip/unix_files/gage_15_24.dat
  SELECT GAGE_25_34.DAT
  ADD
  YR_925,JAS_925,YR_926,JAS_926,YR_927,JAS_927,YR_928,JAS_928,YR_929,JAS_929,Y
  R_930,JAS_930,YR_931,JAS_931,YR_932,JAS_932,YR_933,JAS_933,YR_934,JAS_934
  FROM /jornada/precip/unix_files/gage_25_34.dat
  SELECT GAGE_35_44.DAT
  ADD
  YR_935,JAS_935,YR_936,JAS_936,YR_937,JAS_937,YR_938,JAS_938,YR_939,JAS_939,Y
  R_940,JAS_940,YR_941,JAS_941,YR_942,JAS_942,YR_943,JAS_943,YR_944,JAS_944
  FROM /jornada/precip/unix_files/gage_35_44.dat
  SELECT GAGE_45_54.DAT
  ADD
  YR_945,JAS_945,YR_946,JAS_946,YR_947,JAS_947,YR_948,JAS_948,YR_949,JAS_949,Y
  R_950,JAS_950,YR_951,JAS_951,YR_952,JAS_952,YR_953,JAS_953,YR_954,JAS_954
  FROM /jornada/precip/unix_files/gage_45_54.dat
  SELECT GAGE_55_64.DAT
  ADD
  YR_955,JAS_955,YR_956,JAS_956,YR_957,JAS_957,YR_958,JAS_958,YR_959,JAS_959,Y
  R_960,JAS_960,YR_961,JAS_961,YR_962,JAS_962,YR_963,JAS_963,YR_964,JAS_964
  FROM /jornada/precip/unix_files/gage_55_64.dat
  SELECT GAGE_65_74.DAT
  ADD
  YR_965,JAS_965,YR_966,JAS_966,YR_967,JAS_967,YR_968,JAS_968,YR_969,JAS_969,Y
  R_970,JAS_970,YR_971,JAS_971,YR_972,JAS_972,YR_973,JAS_973,YR_974,JAS_974
  FROM /jornada/precip/unix_files/gage_65_74.dat
  SELECT GAGE_75_84.DAT
  ADD
  YR_975,JAS_975,YR_976,JAS_976,YR_977,JAS_977,YR_978,JAS_978,YR_979,JAS_979,Y
  R_980,JAS_980,YR_981,JAS_981,YR_982,JAS_982,YR_983,JAS_983,YR_984,JAS_984
  FROM /jornada/precip/unix_files/gage_75_84.dat
  SELECT GAGE_85_93.DAT
```

```
ADD  
YR_985,JAS_985,YR_986,JAS_986,YR_987,JAS_987,YR_988,JAS_988,YR_989,JAS_989,Y  
R_990,JAS_990,YR_991,JAS_991,YR_992,JAS_992,YR_993,JAS_993 FROM  
/jornada/precip/unix_files/gage_85_93.dat
```

```
Q STOP  
&end
```

```
#!/usr/local/bin/gawk -f
#
#
# script name:  output_txt2
#
# Nawk(Gawk) file to strip the original data files of headers
# and footnotes
#
# check the content before executing this script.
#
# Date:  18 Aug. 94.
#
# by Vinh Duong, US Army Topographic Engineering Center
#
BEGIN {i=1}

    {line[i]=$0
    if (i>4) {
        if ($1=="-") { exit 0}
        filename="extra/"FILENAME"2" # modify here
        print line[i] > filename
    }
    ++i}
```

```
#!/usr/local/bin/gawk -f
#
# script name:  pre_redist
#
# Nawk(Gawk) file to loosely check the format of the JER grazing data
# files before they are useful for importing into ARC/INFO
#
# check the content before executing this script.
#
# Date:  18 Aug. 94.
#
# by Vinh Duong, US Army Topographic Engineering Center
#
BEGIN {i=1}

    {line[i]=$0
    if (i>4) {
        if ($1=="-") { exit 0}
        if (index($1,"(") || index($2,"(") || index($1,"*") || index($2,"*"))
        {
            print "re-edit file ../unix_files/extra/"FILENAME"2" # modify here
            exit 1
        }
    }
    ++i}
```

```
#!/bin/csh
#
# script name:  output_txt3
#
# usage:  output_txt3 filename
# This script creates a new file which has , (comma) as output
# field separator (needed for ARC/INFO)
# check the content before executing this script.
#
# 23 Aug. 94 by Vinh Duong, US Army Topographic Engineering Center
```

```
#set noglob                #prevent file expansion
```

```
echo -n "Are you sure you know what this script does? (Y/N) "
set choice = $<
if ( $choice !~ ['Y','y'] ) then
    echo "not executing the command"
    exit 0
endif
```

```
echo "\nworking ... \n"
```

```
foreach f (extra/*.txt2) # modify, modify
cut -f1 $f > temp.f1
cut -f2 $f > temp.f2
cut -f3 $f > temp.f3
cut -f4 $f > temp.f4
cut -f5 $f > temp.f5
cut -f6 $f > temp.f6
cut -f7 $f > temp.f7
cut -f8 $f > temp.f8
cut -f9 $f > temp.f9
cut -f10 $f > temp.f10
cut -f11 $f > temp.f11
cut -f12 $f > temp.f12
cut -f13 $f > temp.f13
cut -f14 $f > temp.f14
cut -f15 $f > temp.f15
```

```
paste -d", " temp.f1 temp.f2 temp.f3 temp.f4 temp.f5 temp.f6 temp.f7 \
temp.f8 temp.f9 temp.f10 temp.f11 temp.f12 temp.f13 \
```

```
temp.f14 temp.f15 > $f:t:r.txt3  
end  
rm temp.f*
```

```
/*
/*   amlname:   pastures.aml
/*
/* this one must be run in ARC Module
/* Aug. 30, 1994
/*
ARCEDIT

RELATE RESTORE //JORNADA/PASTURES/STK_DENSITY/INFO!ARC!REL_93
SHOW RELATE PSTR_93
EDIT PASTURES POLY
SEL ALL
CURSOR OPEN /* check CURSOR command

&do &while %:edit.AML$NEXT%
  &sv TOTAL2 = 0.0

  &do i = 1 &to %:edit.PSTR_93//AML$NSEL%
    &sv TOTAL2 = %TOTAL2% + %:edit.PSTR_93//TOTAL%
    &if %i% NE %:edit.PSTR_93//AML$NSEL% &then
      CURSOR RELATE PSTR_93 NEXT
    &end /* &do

  CURSOR RELATE PSTR_93 FIRST

  &do i = 1 &to %:edit.PSTR_93//AML$NSEL%
    &sv :edit.PSTR_93//TOTAL2 = %TOTAL2% /* note here

  /* following four lines are for checking only
  /* uncomment them for checking
  /*   &type Area is %:edit.AREA%
  /*   &type Name is %:edit.NAME%
  /*   &type %TOTAL2% %:edit.PSTR_93//TOTAL2%
  /*   &type

    &if %i% NE %:edit.PSTR_93//AML$NSEL% &then
      CURSOR RELATE PSTR_93 NEXT
    &end /* &do

  CURSOR NEXT
&end /* &do &while
```

CURSOR CLOSE

QUIT NO /\* quit ARCEDIT not saving

&type

&type Current relate is [SHOW RELATES]

&type RELATE DROP (if necessary)

```
10 REM HYPSONDEM.EAS
20 REM
30 REM PCI EASI program which produces a 24K USGS DEM from a contour
40 REM (hypsography) ARC/INFO coverage/ungenerate file. Currently
50 REM only good for vector coverages in UTM projection.
60 REM
70 REM Author: William E. Diego, STC, 09 Mar 94
80 REM Revision: WED, STC, 25 May 94 - Took out SPCS code.
90 REM
100 DOC This is a brief help file for the PCI program 'HYPSONDEM.EAS'.
110 DOC The following conditions must be true for using this program:
120 DOC
130 DOC A) You have an ARC/INFO coverage of contour lines (hypsography)
140 DOC which has been made into a GENERATE file using the ARC
150 DOC command:
160 DOC UNGENERATE LINE <in_cover> <out_generate_file>
170 DOC Please append a '.lin' to <out_generate_file>. PCI will
180 DOC make this a requirement.
190 DOC
200 DOC B) The ARC/INFO coverage is in the UTM projection.
210 DOC_END
220 REM First, create the PCIDSK database file. It requires two
230 REM unsigned 16-bit channels. Why 16U? Not sure - I did it using
240 REM trial & error.
250 REM Channel 1 will hold the gridded vector coverage.
260 REM Channel 2 will hold the interpolated DEM.
270 REM
280 LOCAL $NAME, $AINAME, $PROJ, #METHOD, #SEGLN, #OFFSET
290 PRINT @(1,1,CLREOS)
300 INPUT "Enter name of PCIDSK file to create, e.g., demo.pix: "$NAME
310 FILE=$NAME
320 DBSZ=1024,1024
330 PXSZ=1,1
340 DBNC=0,0,2,0
350 DBLAYOUT="BAND"
360 RUN CIM
370 REM
380 REM Second, clear the database.
390 REM
400 PRINT " "
410 PRINT "Clearing the database"
420 DBOC=1,2
```

```
430 VALU=0,0
440 DBOW=
450 RUN CLR
460 REM
470 REM Third, read the ARC/INFO line coverage (hypsography).
480 REM Actually, this part only prepares a vector channel.
490 REM Also, we georeference the units in the vector channel.
500 REM
510 PRINT @(1,1,CLREOS)
520 INPUT "Enter name of ARC/INFO GENERATE file: "$AINAME
530 PRINT " "
540 PRINT @(1,1,CLREOS)
550 PRINT "GEOREFERENCING/PROJECTION INPUT SECTION"
560 PRINT " "
570 PRINT "Enter UTM information in the format:"
580 PRINT " "
590 INPUT "Zone# Row_ltr Ellipsoid#: "$PROJ
600 ASK "Enter the UPPER LEFT coordinates (eg: x,y): "UPLEFT
610 ASK "Enter the LOWER RIGHT coordinates (eg: x,y): "LORIGHT
620 PRINT " "
630 $PROJ = "UTM " + $PROJ
640 MAPUNITS = $PROJ
650 FILV = $AINAME
660 VECFORM = "ARC"
670 VECUNIT = $PROJ
680 FILE = $NAME
690 #SEGLN = F$LEN($AINAME)
700 IF (#SEGLN < 8) #OFFSET = #SEGLN ELSE #OFFSET = 8
710 DBSN = F$EXTRACT ($AINAME,#SEGLN-#OFFSET+1,#OFFSET)
720 DBSD = "Hypsography from ARC/INFO GENERATE file"
730 RUN VECREAD
740 RUN GEOSET
750 REM
760 REM Fourth, grid the vector coverage and place in db channel 1.
770 REM
780 PRINT @(1,1,CLREOS)
790 PRINT "Creating the vector grid...."
800 DBVS=2
810 REM **** VERY IMPORTANT to NOT SET 'valu' to ANY number ****
820 REM This will allow it to accept the values from the vector
830 REM coverage. Setting it to zero will produce a solid gray grid.
```

```
840 VALU=
850 DBOC=1
860 CONNECT=4
870 VTYPE="LINE"
880 RUN GRDVEC
890 REM
900 REM Fifth, interpolate the grid contours to produce the DEM.
910 REM
920 PRINT " "
930 PRINT "Creating the DEM...."
940 PRINT " "
950 DBIC=1
960 DBOC=2
970 BACKVAL=0
980 PRINT " 1. DIAG"
990 PRINT " 2. SMOOTH"
1000 PRINT " 3. CONIC"
1010 INPUT "Enter number corresponding to grid interpolation method: "#METHOD
1020 CASE (#METHOD) 1;1030, 2;1050, 3;1070
1030 INTMETH="DIAG"
1040 GOTO 1080
1050 INTMETH="SMOOTH"
1060 GOTO 1080
1070 INTMETH="CONIC"
1080 RUN GRDINT
1090 REM
1100 REM Finally, write out the DEM.
1110 REM
1120 PRINT " "
1130 PRINT "Writing out the DEM..."
1140 FILI=$NAME
1150 FILO=$NAME+"DEM"
1160 DBIC=2
1170 DBIW=
1180 RUN DEMWRIT
1190 PRINT " "
1200 PRINT "Program complete."
1210 RETURN
```

```
#!/bin/sh
#
# cnvrtdem
#
# Bourne shell script which 'unblocks' the DEMs created by
# the PCI EASI program 'HYPSONDEM.EAS'. This unblocking is
# necessary for ARC/INFO to read the DEMs correctly.
#
# Author: William E. Diego, STC, 25 May 94
#
case $# in
0)    echo "Usage: cnvrtdem <current filename> <new filename>" ;;
2)    dd if=$1 of=$2 ibs=1024 cbs=1024 conv=unblock;;
*)    echo "Usage: cnvrtdem <current filename> <new filename>" ;;
esac
```

```
/*
/*  amlname:      t_map.aml
/*
/*  creation date: November 4, 1994
/*  author:       MJ Makaio
/*
/*  This aml takes 3 arguments.
/*      arg 1: polygon cover name
/*      arg 2: line cover name
/*      arg 3: point cover name
/*
/*  Example:&r map POL915FA1_0 LIN915FA1_0 PNT915FA1_0
/*
/*      if no line or point covs exist do this:
/*      &r t_map POL915FA1_0 none none
/*
/*
/*
/*
&ARGS poly_cov line_cov point_cov
/*
&severity &error &ignore
&severity &warning &ignore
/*
/*  check for arguments - if no ars, return message
/*
&if [null %poly_cov%] &then
    &return &warning usage: ~
T_MAP <polygon_coverage> <line_coverage or none> <point_coverage or none>
/*
/*
/*  make sure upcase characters used for coverages
/*
&set poly_cov = [Translate %poly_cov%]
&set line_cov = [Translate %line_cov%]
&set point_cov = [Translate %point_cov%]
/*
/*  Check to see if .FRE infofile exists
/*
&if [exists %poly_cov%.FRE -info] &then
    &do
        &DATA ARC INFO
```

```

ARC
SEL %poly_cov%.FRE
ERASE %poly_cov%.FRE
Y
QUIT STOP
&END
&end
&else &type Making %poly_cov%.FRE, hang on.
/*
/*
/*   The frequency file acts as the keyfile to select
/*   the appropriate shade set symbols from the .LUT
/*
/*
FREQUENCY %poly_cov%.PAT %poly_cov%.FRE
PLANT-CODE
~
Y
Y
~
~
Y
N
/*
/*   Because of the universal polygon we must pay
/*   homage to (always the first record), it must be omitted from the
/*   polys which are veggies to be shaded.
/*
/*
&DATA ARC INFO
ARC
SEL %poly_cov%.FRE
RESELECT BY CASE# GT 1
NSELECT
PURGE
Y
QUIT STOP
&END
/*
/*
ap

```

```
/*
/*      Output size of printer, use eps.aml for that output.
/*
pagesize 8.5 11
display 9999
/*
/*      Start the map composition
/*
map %poly_cov%.map
/*
/*      Establish symbol sets
/*
shadeset carto.shd
markerset usgs.mrk
lineset carto.lin
/*
/*      draw the box outline on the map, where the map will go.
/*
linesymbol 103
box 1 3.4 7.5618 9.9618
mape %poly_cov%
maplimits 1 3.4 7.5618 9.9618
mapposition cen cen
mapunits meters
mapscale 6
/*
/*
/*      check to see if line cov exists
/*
linesymbol 102
&if [exists %line_cov% -line] &then
  arcs %line_cov%
&else &type No line cov, moving on with aml.
/*
/*
/*
linesymbol 101
polys %poly_cov%
markersymbol 123
polygonshades %poly_cov% PLANT-CODE ../PLANT_CODE.LUT
textquality kern
textfont 94021
```

```

textsize 10 pt
/*
/*   check to see if point cov exists
/*
&if [exists %point_cov% -point] &then
  &do
    points %point_cov%
    pointtext %point_cov% PLANT-CODE ../PLANT_CODE.LUT UC
  &end
&else &type No point cov, moving on with aml.
/*
/*
/*
move 4.5 3.75
text 'JORNADA EXPERIMENTAL RANGE' cc
/*
/*   Make the scale
/*
move 7.5 2.75
text 'Scale 1:6' cc
move 7.5 2.2
text 'Centimeters' cc
shadeset color.shd
shadesymbol 1
patch 7.1063 2.5 7.5 2.6
linesymbol 101
box 7.5 2.5 7.8937 2.6
box 7.1063 2.5 7.5 2.6
textfont 94021
textsize 10 pt
move 7.1063 2.4
text '0' cc
move 7.8937 2.4
text '12' cc
move 3.5 2.75
/*
/*   Legend, logo, and title
/*
textsize 12 pt
text 'LEGEND' cc
mapscale automatic

```

*ISEM Final Report, Volume 1*

```
maplimits 1 2.7 1.5 3.2
mapposition cen cen
mape image /export/home/makaio/images/teclogo.rs
image /export/home/makaio/images/teclogo.rs
/*
/*   North Arrow
/*
line 7.5 0.5 7.5 2
line 7.45 0.9 7.5 2
line 7.45 0.9 7.5 0.95
shade 7.5 0.95 7.55 0.9 7.5 2
line 7.55 0.5 7.55 0.8
line 7.45 0.5 7.45 0.8
shade 7.45 0.8 7.55 0.65 7.55 0.5 7.45 0.65
/*
/*   Make the year
/*
&setvar year := [substr %poly_cov% 4 3]
&cs num_one = 1
&cs y = %num_one% %year%
/*
/*   Make the month
/*
&setvar month := [substr %poly_cov% 7 1]
/*
/*   Get the right month
/*
&select %month%
  &when A
    &setvar month = JANUARY
  &when B
    &setvar month = FEBRUARY
  &when C
    &setvar month = MARCH
  &when D
    &setvar month = APRIL
  &when E
    &setvar month = MAY
  &when F
    &setvar month = JUNE
  &when G
    &setvar month = JULY
```

ISEM Final Report, Volume I

```

&when H
  &setvar month = AUGUST
&when I
  &setvar month = SEPTEMBER
&when J
  &setvar month = OCTOBER
&when K
  &setvar month = NOVEMBER
&when L
  &setvar month = DECEMBER
&end
/*
/* Find the name of the quadrat, i.e. A1
/*
&setvar q_name := [substr %poly_cov% 8 2]
/*
/*
&setvar phrase := QUADRAT DATA
/*
/* Need a space: &s p =
/*
&s p =
/*
/* Now, concatenate and make the title
/*
&s z = %q_name% %p% %phrase% %p% %month% %p% %y%
textsize 14 pt
move 4.5 0.5
text [quote %z%] cc
/*
/* This creates the legend boxes with correct
/* shade symbols, line symbols and explanation
/*
shadeset carto.shd
keyseparation 0.15 0.25
keybox 0.50 0.25
textsize 10 pt
keyarea 1 0.5 4 2.5
/*
/* This reselect finds only those symbols and text
/* that match the poly_cov's unique plant-codes

```

/\*

RESELECT ../PLANT\_CODE.LUT INFO KEYFILE %poly\_cov%.FRE PLANT-CODE

keyshade ../PLANT\_CODE.LUT INFO SYMBOL LABEL

keyarea 4.5 0.5 5.5 2.5

keybox 0.50 0

keyline ../line.key nobox

keyarea 4.5 0.5 5.5 2

KEYMARKER ../marker.key nobox

```

/*
/*  amlname:      t_quad.aml
/*
/*  creation date: November 4, 1994
/*  author:      MJ Makaio
/*
/*  This aml takes 3 arguments.
/*      arg 1: polygon cover name
/*      arg 2: line cover name
/*      arg 3: point cover name
/*
/*  Example:&r t_quad POL915FA1_0 LIN915FA1_0 PNT915FA1_0
/*
/*      if no line or point covs exist do this:
/*      &r quadrat POL915FA1_0 none none
/*
/*  aml creates a postscript file, 8.5x11 pagesize
/*
/*
&ARGS poly_cov line_cov point_cov
/*
&severity &error &ignore
&severity &warning &ignore
/*
/*  check for arguments - if no ars, return message
/*
&if [null %poly_cov%] &then
  &return &warning usage: ~
T_QUAD <polygon_cover> <line_cover or none> <point_cover or none>
/*
/*
/*  make sure upcase characters used for coverages
/*
&set poly_cov = [Translate %poly_cov%]
&set line_cov = [Translate %line_cov%]
&set point_cov = [Translate %point_cov%]
/*
/*  Check to see if .FRE infofile exists
/*
&if [exists %poly_cov%.FRE -info] &then
  &do

```

```
&DATA ARC INFO
ARC
SEL %poly_cov%.FRE
ERASE %poly_cov%.FRE
Y
QUIT STOP
&END
&end
&else &type Making %poly_cov%.FRE, hang on.
/*
/*
FREQUENCY %poly_cov%.PAT %poly_cov%.FRE
PLANT-CODE
~
Y
Y
~
~
Y
N
/*
/*
&DATA ARC INFO
ARC
SEL %poly_cov%.FRE
RESELECT BY CASE# GT 1
NSELECT
PURGE
Y
QUIT STOP
&END
/*
/*
ap
pagesize 8.5 11
display 1040 2
%poly_cov%.eps
lineset carto.lin
linesymbol 103
box 1 3.4 7.5618 9.9618
mape %poly_cov%
maplimits 1 3.4 7.5618 9.9618
```

```
mapposition cen cen
mapunits meters
mapscale 6
/*
/*    check to see if line cov exists
/*
linesymbol 102
&if [exists %line_cov% -line] &then
    arcs %line_cov%
&else &type No line cov, moving on with aml.
/*
/*
/*
linesymbol 101
polys %poly_cov%
markerset usgs.mrk
markersymbol 123
shadeset carto.shd -
polygonshades %poly_cov% PLANT-CODE ../PLANT_CODE.LUT
textquality kern
textfont 94021
textsize 10 pt
/*
/*    check to see if point cov exists
/*
&if [exists %point_cov% -point] &then
    &do
        points %point_cov%
        pointtext %point_cov% PLANT-CODE ../PLANT_CODE.LUT UC
    &end
&else &type No point cov, moving on with aml.
/*
/*
/*
move 4.5 3.75
text 'JORNADA EXPERIMENTAL RANGE' cc
move 7.5 2.75
text 'Scale 1:6' cc
move 7.5 2.2
text 'Centimeters' cc
shadeset color.shd
```

```
shadesymbol 1
patch 7.1063 2.5 7.5 2.6
linesymbol 101
box 7.5 2.5 7.8937 2.6
box 7.1063 2.5 7.5 2.6
textfont 94021
textsize 10 pt
move 7.1063 2.4
text '0' cc
move 7.8937 2.4
text '12' cc
move 3.5 2.75
textsize 12 pt
text 'LEGEND' cc
mapscale automatic
maplimits 1 2.7 1.5 3.2
mapposition cen cen
mape image /export/home/makaio/images/teclogo.rs
image /export/home/makaio/images/teclogo.rs
line 7.5 0.5 7.5 2
line 7.45 0.9 7.5 2
line 7.45 0.9 7.5 0.95
shade 7.5 0.95 7.55 0.9 7.5 2
line 7.55 0.5 7.55 0.8
line 7.45 0.5 7.45 0.8
shade 7.45 0.8 7.55 0.65 7.55 0.5 7.45 0.65
textsize 14 pt
/*
/*      Different titles for each quadrat
/*
/*      Make the year
/*
/*
&setvar year := [substr %poly_cov% 4 3]
&s num_one = 1
&s y = %num_one% %year%
/*
/*
/*      Make the month
/*
/*
&setvar month := [substr %poly_cov% 7 1]
```

```

/*
/*
/*   Get the right month
/*
/*
&select %month%
  &when A
    &setvar month = JANUARY
  &when B
    &setvar month = FEBRUARY
  &when C
    &setvar month = MARCH
  &when D
    &setvar month = APRIL
  &when E
    &setvar month = MAY
  &when F
    &setvar month = JUNE
  &when G
    &setvar month = JULY
  &when H
    &setvar month = AUGUST
  &when I
    &setvar month = SEPTEMBER
  &when J
    &setvar month = OCTOBER
  &when K
    &setvar month = NOVEMBER
  &when L
    &setvar month = DECEMBER
&end
/*
/*   Find the name of the quadrat, i.e. A1
/*
&setvar q_name := [substr %poly_cov% 8 2]
/*
/*
&setvar phrase := QUADRAT DATA
/*
/*   Need a space: &s p =
/*

```

ISEM Final Report. Volume I

```
&cs p =
/*
/*   Now, put the month, year after QUADRAT DATA
/*
&cs z = %q_name% %p% %phrase% %p% %month% %p% %y%
move 4.5 0.5
text [quote %z%] cc
/*
/*
shadeset carto.shd
keyseparation 0.15 0.25
keybox 0.50 0.25
textsize 10 pt
keyarea 1 0.5 4 2.5
RESELECT ../PLANT_CODE.LUT INFO KEYFILE %poly_cov%.FRE PLANT-CODE
keyshade ../PLANT_CODE.LUT INFO SYMBOL LABEL
keyarea 4.5 0.5 5.5 2.5
keybox 0.50 0
keyline ../line.key nobox
keyarea 4.5 0.5 5.5 2
KEYMARKER ../marker.key nobox
quit ..
/*
/*   Comment out below if you do not wish
/*   file to be printed out after running aml
/*
/*
&set poly_cov = [locase %poly_cov%]
&sys lp %poly_cov%.eps
```

ISEM Final Report, Volume I

```
/*
/*
/*  amlname:      t_eps_c_avg.aml
/*
/*  creation date: November 4, 1994
/*  author:      MJ Makaio
/*
/*  This aml takes 1 arguments.
/*      arg 1: line cover name
/*
/*  Example:&r t_eps_c_avg line_cover
/*
/*
&ARGS line_cov
/*
/*
&severity &error &ignore
&severity &warning &ignore
/*
/*  check for arguments - if no ars, return message
/*
/*
/*
/*  make sure upcase characters used for coverages
/*
&set line_cov = [Translate %line_cov%]
/*
/*
ap
pagesize 8.5 11
display 1040 2
/*
/*
%line_cov%.eps
/*
/*  Establish symbol sets
/*
shadeset carto.shd
markerset water.mrk
markersymbol 136
markersize .3
```

```
lineset carto.lin
/*
/*      draw the box outline on the map, where the map will go.
/*
lineset carto.lin
shadeset plotter.shd
linesymbol 103
box 1 3 8 10.5
textquality kern
textfont 94021
textsize 10 pt
maplimits 1 3 8 10.5
mapunits meters
mapposition cen cen
mape past_bnd
mapscale 200000
linesymbol 129
polys past_bnd
linesymbol 101
arctext %line_cov% contour # LINE # BLANK
points gage_pt
/* pointtext gage_pt station
/*
/*
/*
move 7.5 2.75
text 'Scale 1:200000' cc
move 7.5 2.2
text 'METERS' cc
shadeset color.shd
shadesymbol 1
patch 7.1063 2.5 7.5 2.6
linesymbol 101
box 7.5 2.5 7.8937 2.6
box 7.1063 2.5 7.5 2.6
textfont 94021
textsize 10 pt
move 7.1063 2.4
text '0' cc
move 7.8937 2.4
text '4000' cc
```

```

/*
/*  Legend, logo, and title
/*
move 3.5 2.75
textsize 12 pt
text 'LEGEND' cc
move 4.5 10.25
text 'JORNADA EXPERIMENTAL RANGE' cc
move 4.5 0.5
text '1965 - 1993 AVERAGE YEARLY TOTAL PRECIPITATION CONTOURS' CC
mapscale automatic
maplimits 1 9.9 1.65 10.4
mapposition cen cen
map image /export/home/makaio/images/teclogo.rs
/*
/*  this logo location will be different, change to appropriate dir
/*
image /export/home/makaio/images/teclogo.rs
/*
/*  North Arrow
/*
line 7.5 0.5 7.5 2
line 7.45 0.9 7.5 2
line 7.45 0.9 7.5 0.95
shade 7.5 0.95 7.55 0.9 7.5 2
line 7.55 0.5 7.55 0.8
line 7.45 0.5 7.45 0.8
shade 7.45 0.8 7.55 0.65 7.55 0.5 7.45 0.65
/*
textsize 10 pt
keybox 0.50 0
keyarea 1 0.5 4 2.5
keymarker marker.key nobox
keyarea 1 0.5 4 2
keyseparation 0.15 0.25
keybox 0.50 0.25
keyline line.key nobox
quit
/*
/*  Uncomment the following to print from Arc prompt
/*

```

```
/*&set line_cov = [locase %line_cov%]  
/*&sys lp, %line_cov%.eps  
/*
```

```

/*
/*  amlname:      t_4paseps.aml
/*
/*  creation date: November 14, 1994
/*  author:      MJ Makaio
/*
/*  This aml takes 1 arguments.
/*      arg 1: polygon cover name
/*
/*  Example:&r pastures poly_cov
/*
/*
&ARGS poly_cov
/*
&severity &error &ignore
&severity &warning &ignore
/*
/*  check for arguments - if no ars, return message
/*
&if [null %poly_cov%] &then
    &return &warning usage: ~
    T_4PASEPS <polygon_cover >
/*
/*
/*  make sure upcase characters used for coverages
/*
&set poly_cov = [Translate %poly_cov%]
/*
/*  Check to see if .FRE infofile exists
/*
&if [exists %poly_cov%.FRE -info] &then
    &do
        &DATA ARC INFO
        ARC
        SEL %poly_cov%.FRE
        ERASE %poly_cov%.FRE
        Y
        QUIT STOP
        &END
    &end

```

```
&else &type Making %poly_cov%.FRE, hang on.
/*
/*
FREQUENCY %poly_cov%.PAT %poly_cov%.FRE
NAME
~
Y
Y
~
~
Y
N
/*
/*
&DATA ARC INFO
ARC
SEL %poly_cov%.FRE
RESELECT BY CASE# GT 1
NSELECT
PURGE
Y
QUIT STOP
&END
/*
/*
ap
display 1040 2
%poly_cov%.eps
/*
pagesize 8.5 11
lineset carto.lin
shadeset plotter.shd
linesymbol 103
box 1 3 8 10.5
maplimits 1 3 8 10.5
mape %poly_cov%
mapposition cen cen
mapunits meters
linesymbol 101
mapscale 200000
RESELECT %poly_cov% POLYS NAME CN 'DONA'
ASEL %poly_cov% POLYS NAME CN 'HORS'
```

```
NSEL %poly_cov% POLYS
RESELECT STK_DENSITY/STK_93.LUT INFO KEYFILE %poly_cov%.FRE NAME
POLYGONSHADES %poly_cov% NAME STK_DENSITY/STK_93.LUT
CLEARSEL
polys %poly_cov%
textquality kern
textfont 94021
textsize 10 pt
POLYGONTEXT %poly_cov% NAME
MAPSCALE AUTOMATIC
move 4.5 10.25
text 'JORNADA EXPERIMENTAL RANGE' cc
maplimits 1 9.9 1.65 10.4
mapposition cen cen
mape image /export/home/makaio/images/teclogo.rs
image /export/home/makaio/images/teclogo.rs
linesymbol 101
shadesymbol 1
line 7.5 0.5 7.5 2
line 7.45 0.9 7.5 2
line 7.45 0.9 7.5 0.95
shade 7.5 0.95 7.55 0.9 7.5 2
line 7.55 0.5 7.55 0.8
line 7.45 0.5 7.45 0.8
shade 7.45 0.8 7.55 0.65 7.55 0.5 7.45 0.65
patch 7.1063 2.5 7.5 2.6
box 7.5 2.5 7.8937 2.6
box 7.1063 2.5 7.5 2.6
move 7.5 2.75
textsize 10 pt
text 'Scale 1:200000' cc
move 7.5 2.2
text 'Meters' cc
show shadesymbol
move 7.1063 2.4
text '0' cc
move 7.8937 2.4
text '4000' cc
keyseparation 0.15 0.15
keybox 0.50 0.25
textsize 10 pt
```

```
keyarea 1 0.5 7 2.5
keyshade STK_DENSITY/SYMBOL.LUT INFO SYMBOL LEGEND
textsize 12 pt
move 3 2.75
text 'LEGEND' cc
move 4.5 0.5
text 'GRAZING INTENSITY ANNUAL TOTAL, 1993' CC
quit
/*
/* put back to lower case if want to print from here
/*
/* &set poly_cov = [locase %poly_cov%]
/* &sys lp %poly_cov%.eps
```

```

/*
/*  amlname:      mul_dw.aml
/*
/* Caution: this file massively deletes workspaces automatically
/* Make sure you know what it does
/*
&do i &list ~
915fa1_0.lin 915ja1_0.lin 916ea1_0.lin 917fa1_0.lin 918ia1_0.lin ~
919ga1_0.lin 919ja1_0.lin 920ja1_0.lin 921ja1_0.lin 922ja1_0.lin ~
923ja1_0.lin 924ja1_0.lin 925ja1_0.lin 926ia1_0.lin 927ia1_0.lin ~
928ia1_0.lin 929ia1_0.lin 930ha1_0.lin 931ia1_0.lin 932ia1_0.lin ~
933ja1_0.lin 934ja1_0.lin 935ea1_0.lin 935ja1_0.lin 936ja1_0.lin ~
937ja1_0.lin 938ia1_0.lin 940aa1_0.lin 941ba1_0.lin 942aa1_0.lin ~
942ja1_0.lin 943la1_0.lin 944ia1_0.lin 945ia1_0.lin 947ba1_0.lin ~
947ia1_0.lin 949ia1_0.lin 950ka1_0.lin 951ha1_0.lin 952ia1_0.lin ~
956ha1_0.lin 957ha1_0.lin 958ia1_0.lin 959ia1_0.lin 971ga1_0.lin ~
972ha1_0.lin 973ha1_0.lin 974fa1_0.lin 975ha1_0.lin 976ga1_0.lin ~
977ga1_0.lin
&s worksp yr_[substr %i% 1 3]
&if [exists %worksp% -workspace] or [exists %worksp% -directory] &then
  &do
    DELETEWORKSPACE %worksp%
    N
  &end
&else
  &type %worksp% not existing
&end /* &do

```

```
#!/usr/local/bin/gawk -f
#
#
# script name:  get_avg65_93
#
# Nawk(Gawk) file to get average values from year 1965 to 93 into a separate
# file used for JER precip data
#
# check the content before executing this script.
#
# Date:  5 Oct. 94.
#
# by Vinh Duong, US Army Topographic Engineering Center
#
# FILENAME should be /jornada/precip/unix_files/extra/joranpre.txt

BEGIN {i=1; filename = "avg65_93.txt"}      # modify filename

    {
        line[i]=$0
        if (i >= 6)
            if ( $1 >= 1965 )
                for (j = 2; j <= NF; j++)
                {
                    { s[j] += $j }
                    if (i == 85)
                        printf("%s\n",s[j]/(NR - 56)) > filename
                }

        i++
    }
}
```

```

#!/usr/local/bin/gawk -f
#
#
# script name:  get_precipXY
#
# Nawk(Gawk) file to get X, Y values and Station Names into separate files
# used for JER precip data
#
# check the content before executing this script.
#
# Date:  20 Sep. 94.
#
# by Vinh Duong, US Army Topographic Engineering Center
#
# FILENAME should be /jornada/precip/unix_files/extra/joranpre.txt

BEGIN {i=1}

    {
        line[i]=$0
        if (i == 2) { filename="temp1" } # modify filename
        if (i == 3) { filename="temp2" }
        if (i == 4) { filename="temp3" }
        if (i != 1)
            for (j = 2; j <= NF; j++)
                printf("%s\n", $j) > filename
        if (i > 4) exit 0
        i++
    }

#
# script name:  mcut
#
cut -f1-20 -d, gage.dat > gage_15_24.dat
cut -f21-40 -d, gage.dat > gage_25_34.dat
cut -f41-60 -d, gage.dat > gage_35_44.dat
cut -f61-80 -d, gage.dat > gage_45_54.dat
cut -f81-100 -d, gage.dat > gage_55_64.dat
cut -f101-120 -d, gage.dat > gage_65_74.dat
cut -f121-140 -d, gage.dat > gage_75_84.dat
cut -f141- -d, gage.dat > gage_85_93.dat

```

```
#!/usr/local/bin/gawk -f
#
#
# script name:  mgenerate
#
# Nawk(Gawk) file to generate a bunch of items useful for ARC/INFO
#
# check the content before executing this script.
#
# Date:  15 Sep. 94.
#
# by Vinh Duong, US Army Topographic Engineering Center
#
BEGIN {i = 1;filename="items_15_24.txt"} # modify filename

    {
        for(j = 15; j <= 93; j++)
        {
            printf(" %s%s,6,6,N,2\n","YR_9",j) >> filename
            printf(" %s%s,6,6,N,2\n","JAS_9",j) >> filename
            if (i == 10)
            {
                i = 0
                if ((j+10) < 93)
                    filename = "items_"j+1_"j+10".txt"
                else
                    filename = "items_"j+1_"_93.txt"
            }
            i++
        }
    }
}
```



**APPENDIX I  
GIS BACKGROUND DATA**



# Dona Ana County New Mexico

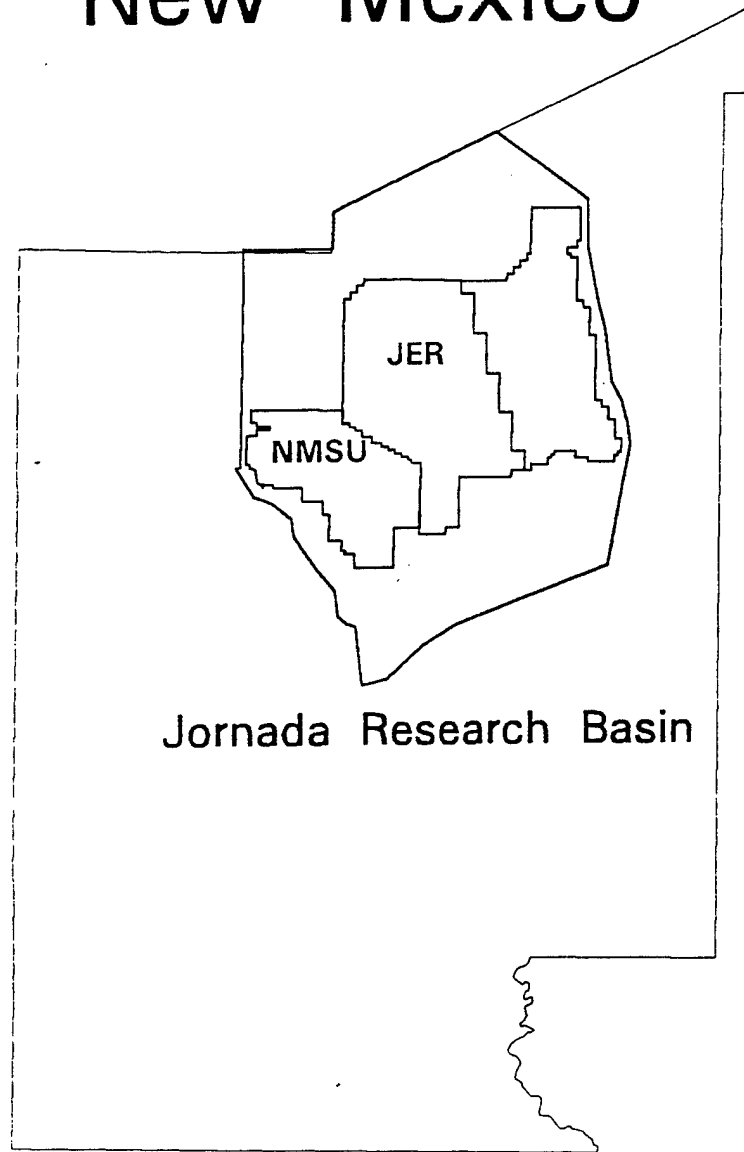

Jornada Research Basin

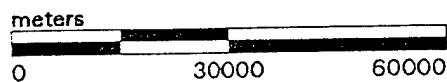

# JER and NMSU Pasture Boundaries

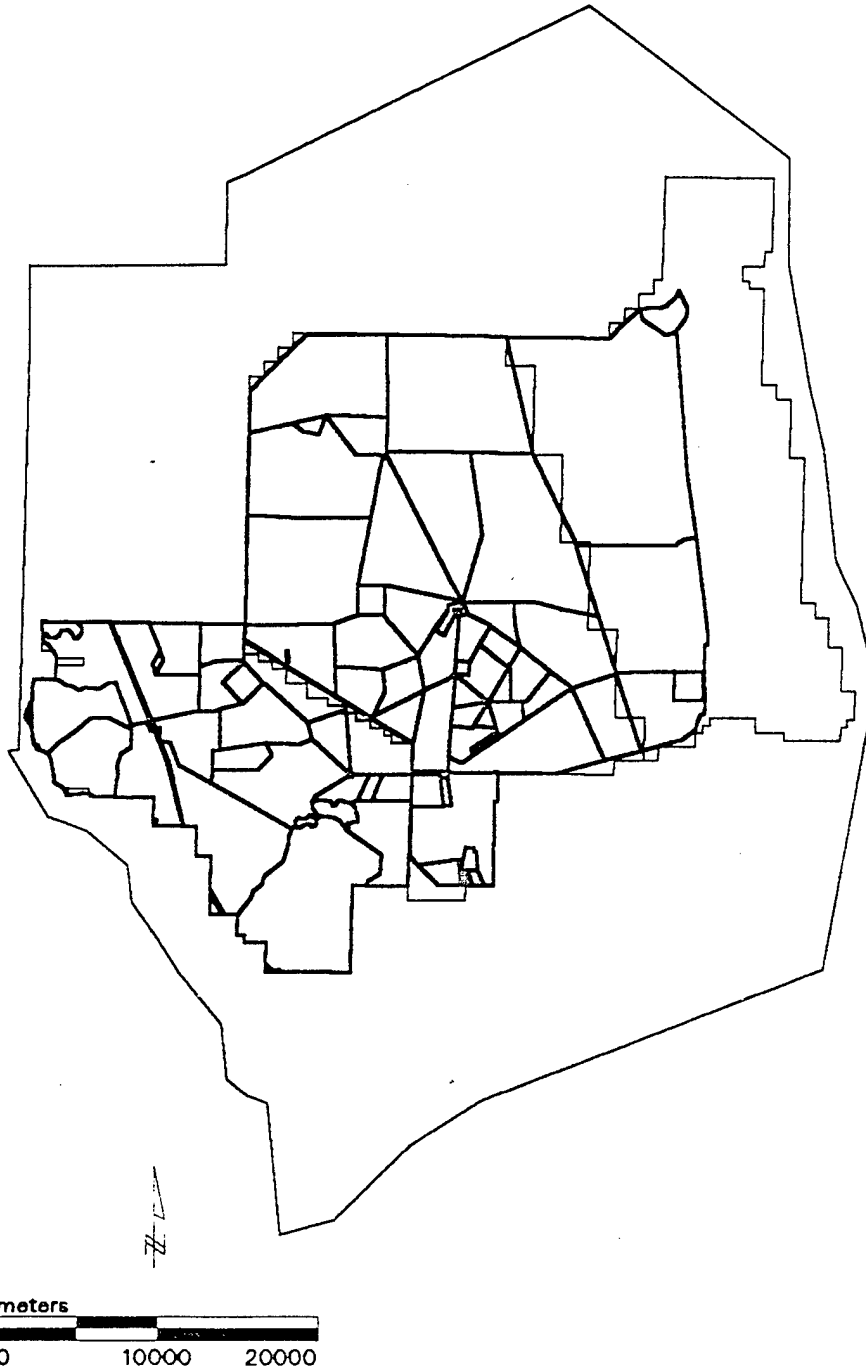

# JER and NMSU Raingage Locations

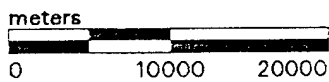
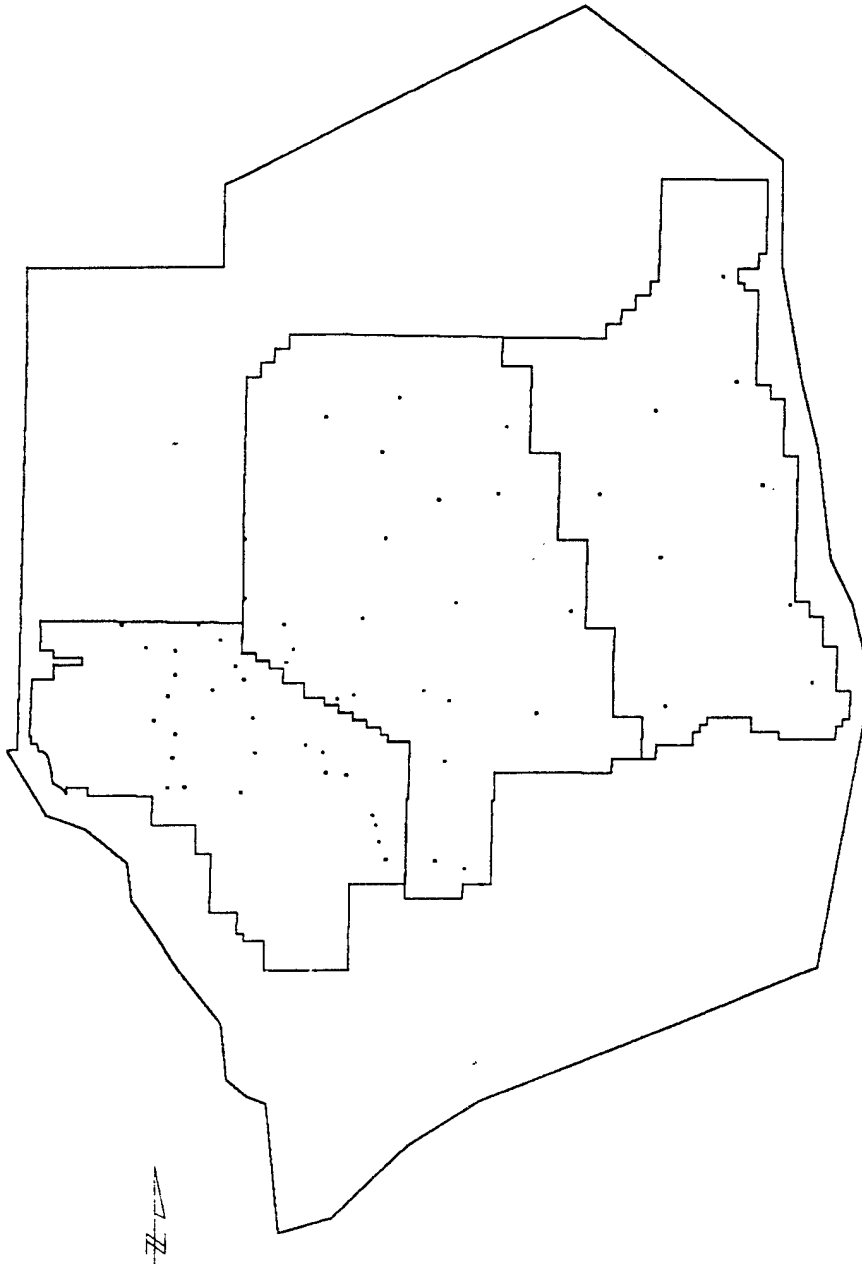

# JER and NMSU Well Locations

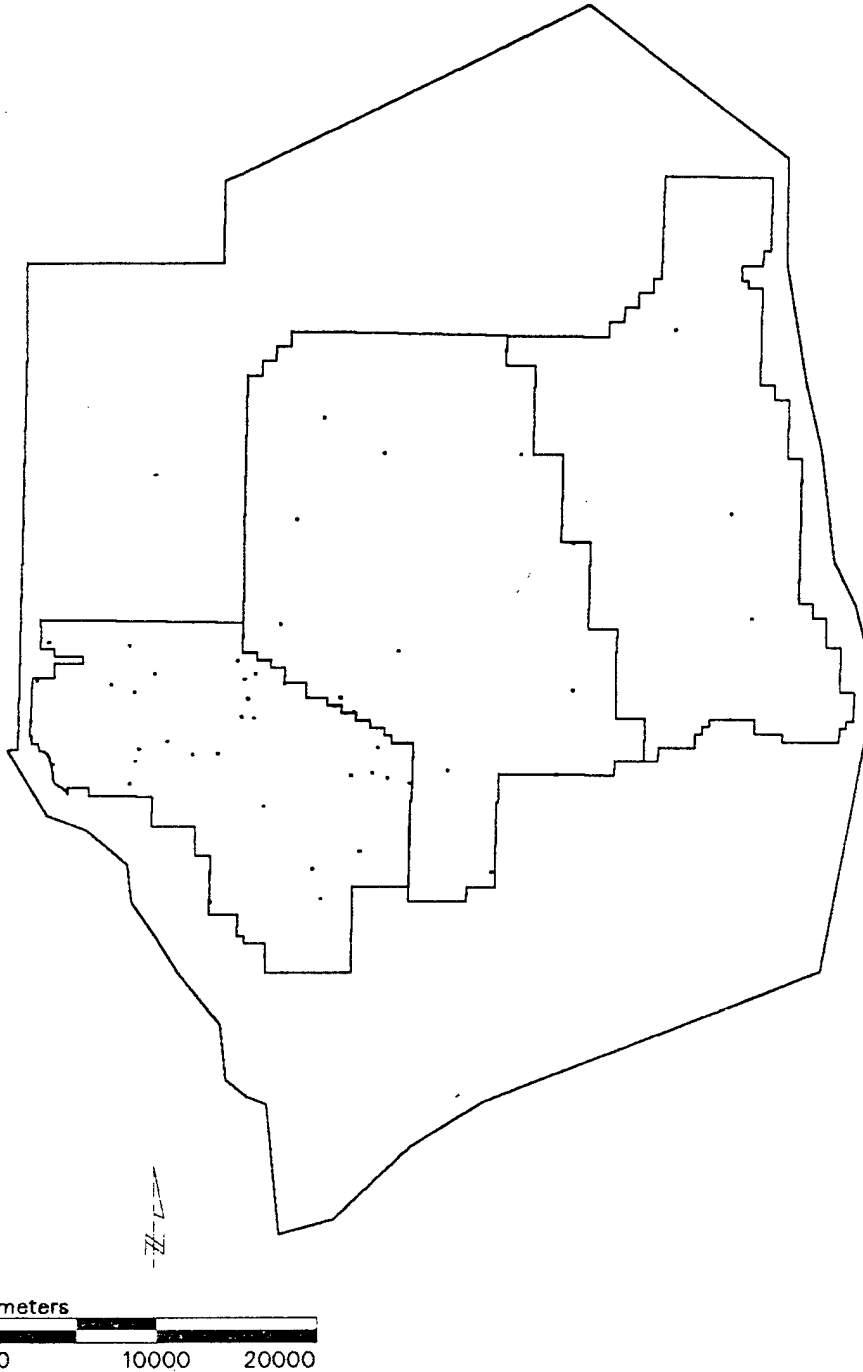

# JER Elevation

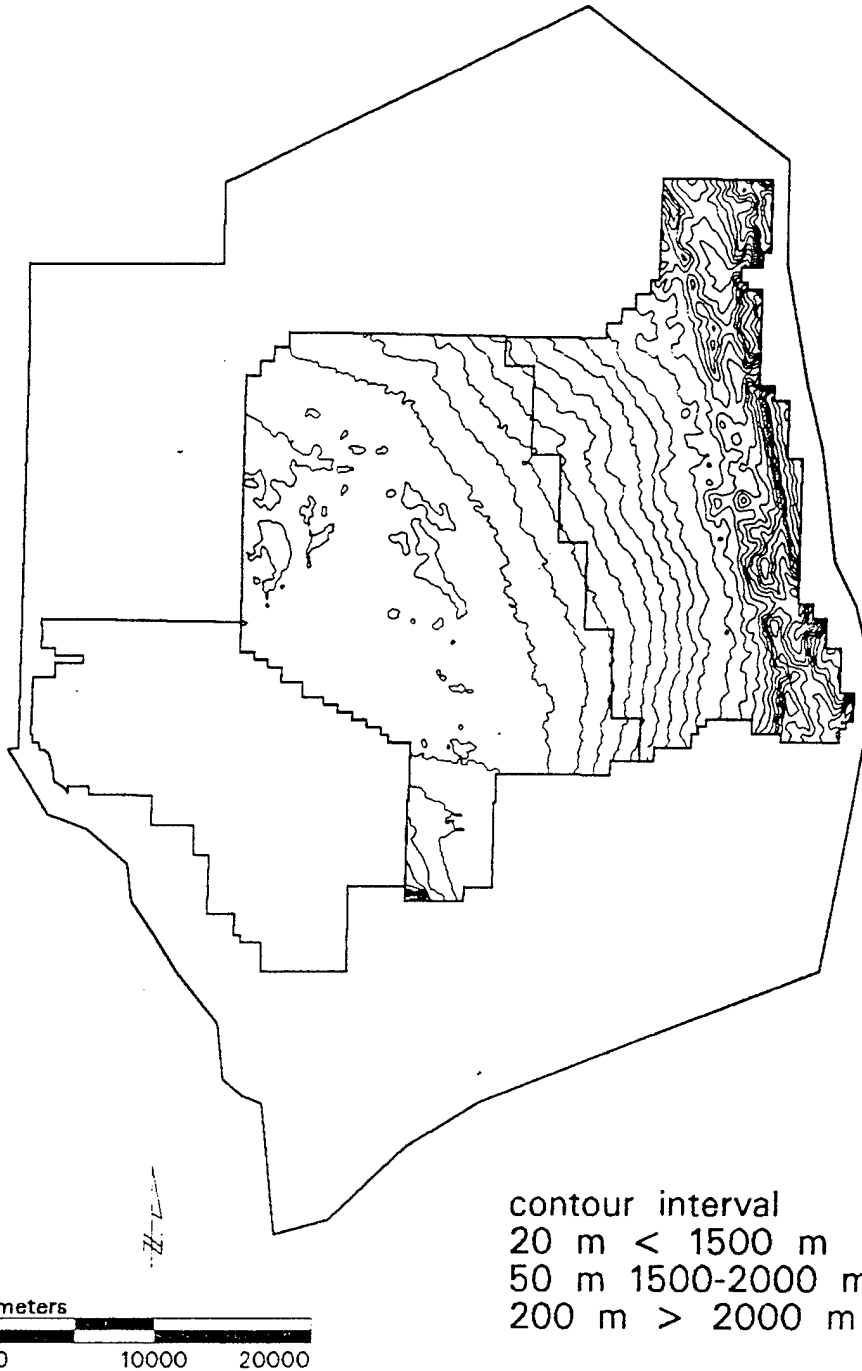

# JER Soils

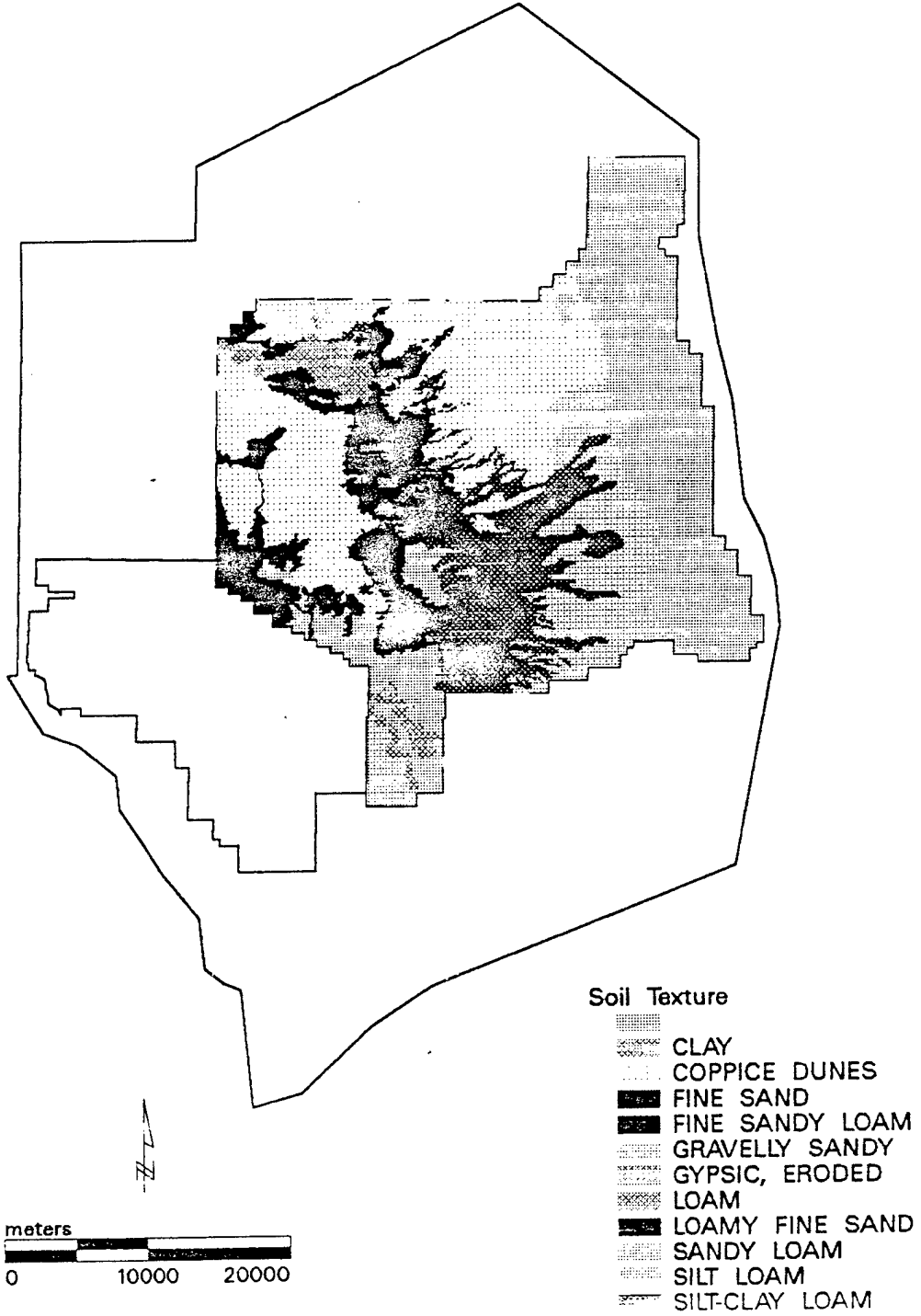

# JER Vegetation

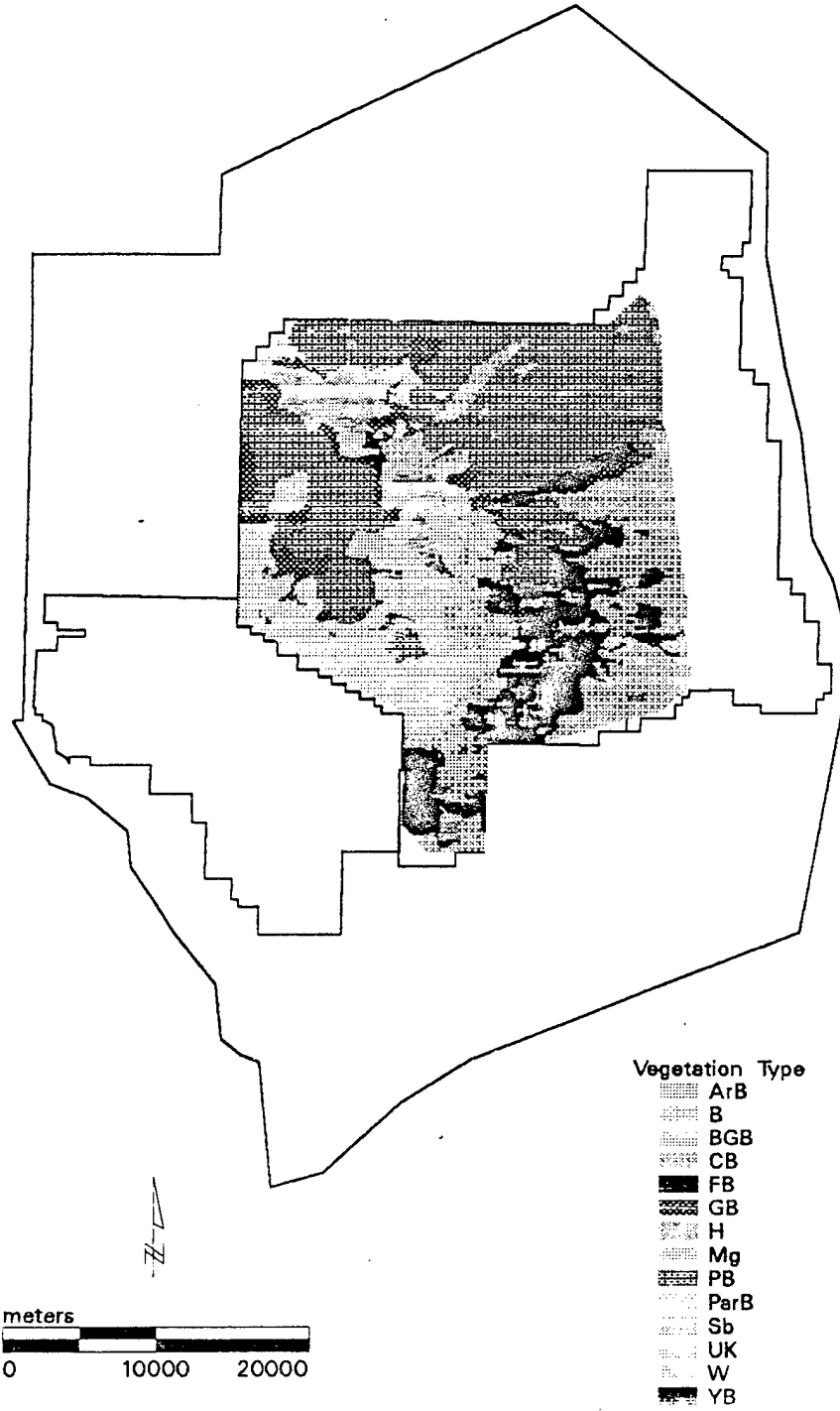



**APPENDIX J  
HABITAT CLASSIFICATIONS**



## Habitat Classification Example

Hutchinson and Warren (1983) have mapped semi-arid vegetation at the Jornada with the premise of meeting monitoring needs. They concluded that imagery-based classification/monitoring schemes must identify, at a minimum, vegetative life forms (i.e. shrubs, grasses, forbs). Their reasoning for this was based on their concept of shrub invasion when arid and semi-arid grasslands become disturbed. The following pages represent their vegetation/habitat classes, based on field data and satellite image interpretation. In mapping the current project area, we found that the Hutchinson and Warren classification was too broad for our needs. Therefore, we have proposed the methods described in section 4.4.1.

## VEGETATION MAPPING UNITS FOR THE JORNADA STUDY AREA

The following vegetation association descriptions are organized by landform and are ranked approximately by abundance of grass within each landform class. The numbers beside each description correspond to the numbers on the vegetation maps.

### 1. Sandy uplands

11. *Bouteloua eriopoda/Sporobolus spp.* Grassland with low shrub cover and high perennial grass diversity. Total cover is approximately 20 to 40 percent.
12. *Sporobolus spp./Gutierrezia sarothrae.* Grassland with snakeweed and moderate grass cover, but few mesquite.
13. *Gutierrezia sarothrae/Sporobolus spp.* Stands of snakeweed with low grass cover (10%) and few mesquite.
14. *Prosopis glandulosa/Gutierrezia sarothrae.* Shrub association dominated by mesquite and snakeweed with low grass cover and no coppice dune formation.
15. *Prosopis glandulosa/Gutierrezia sarothrae.* Shrub association dominated by mesquite and snakeweed with very low grass cover and distinct coppice dune formation.
16. *Dalea scoparia/Ephedra trifurca.* Shrubland with coppice dune formation dominated by broom dalea. Low grass cover.
17. *Acacia constricta/Prosopis glandulosa.* Shrubland with coppice dune formation dominated by white-thorn acacia.

### 2. Silty bottomlands

21. *Hilaria mutica/mixed grass.* Grassland in small, well watered swales usually with 60 to 80 percent cover and scattered shrubs.
22. *Hilaria mutica.* Uniform stands of tobosa with few associated species and 20 to 40 percent cover.
23. *Scleropogon brevifolia/Hilaria mutica.* Grassland with mixed stands of burrograss and tobosa with uniform low cover of 10 to 20 percent.





24. *Scleropogon brevifolia/Hilaria mutica*. Mixed stands of burrograss and tobosa with variable patchy cover, frequently with large areas of bare ground.
  25. *Scleropogon brevifolia/Flourensia cernua*. Low cover stands of burrograss with an overstory of tarbush.
  26. *Hilaria mutica/Prosopis glandulosa*. Mosaic of silty swales with tobosa and sandy ridges with mesquite. Individual patches are too small to be discriminated at this scale.
3. Gravelly uplands
31. *Prosopis glandulosa/Larrea tridentata*. Scrubland of creosotebush and mesquite with low grass cover. Gravel is composed of caliche fragments.
  32. *Larrea tridentata/Flourensia cernua*. Open stands of creosotebush with scattered tarbush and snakeweed with low grass cover. Gravel is mostly of volcanic or metamorphic origin.
  33. *Larrea tridentata/Prosopis glandulosa*. Open stands of creosotebush and mesquite on dissected gravelly slopes with low grass cover. These slopes extend from the Jornada Plain escarpment down to the Rio Grande floodplain.
  34. *Larrea tridentata/mixed shrub*. Sparse stands of creosotebush with scattered shrubs and succulents. These rocky slopes were not visited at many locations and their floristic composition is uncertain.

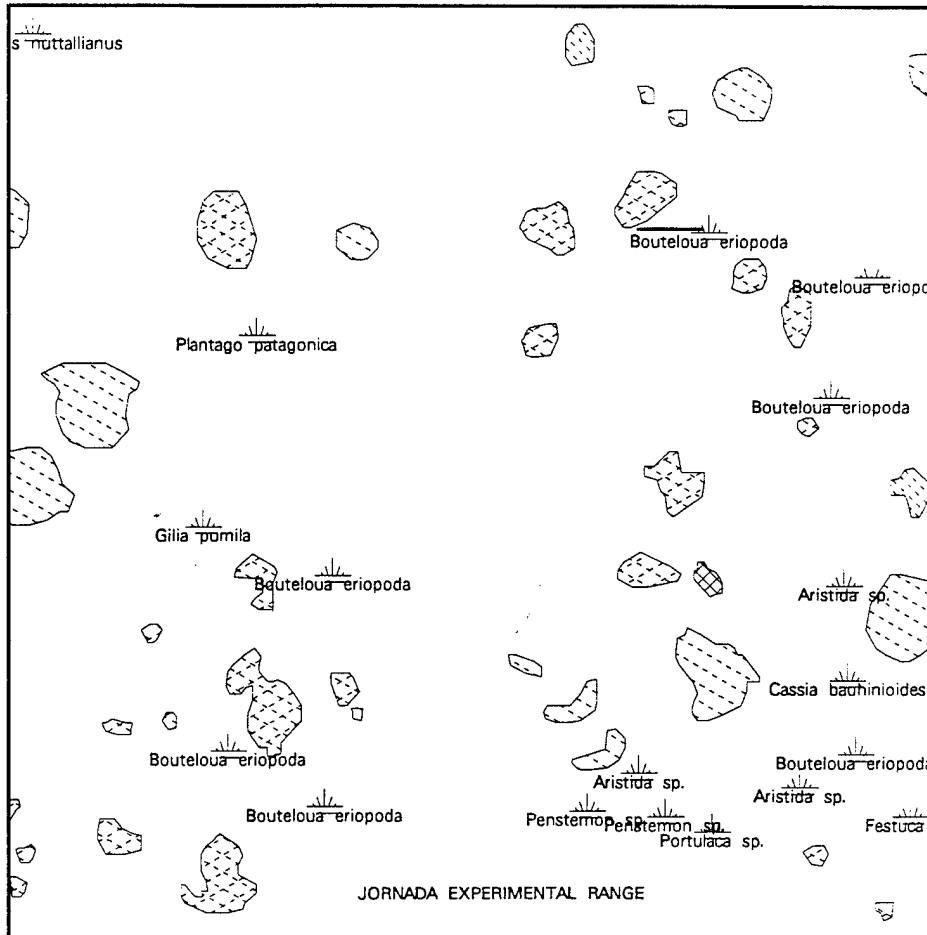

**APPENDIX K  
MAPS AND IMAGES**





LEGEND

-  Aristida sp.
-  Bouteloua eriopoda
-  Evolvulus nuttallianus
-  Portulaca sp.

-  Stolon Representation
-  Shoots



Scale 1:6  
0 12  
Centimeters

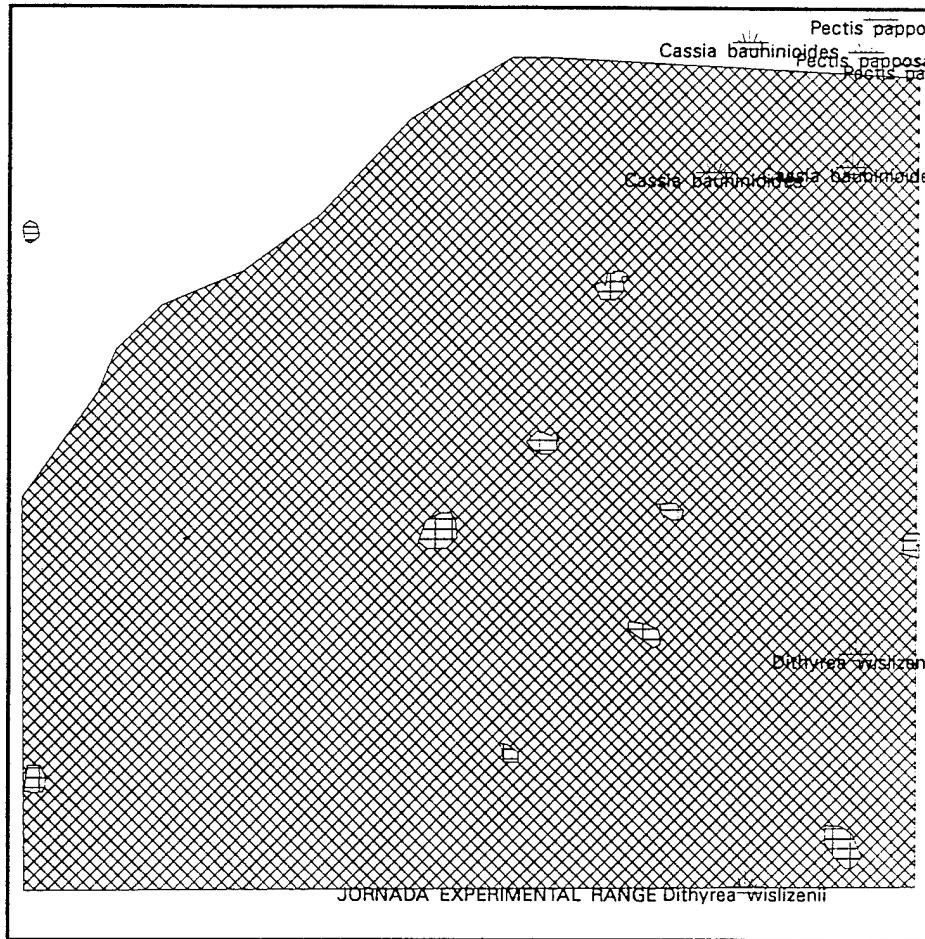

A1 QUADRAT DATA JUNE 1915



LEGEND

-  Gutierrezia sarothrae
-  Prosopis glandulosa
-  Sporobolus flexuosus

 Stolon Representation

 Shoots

Scale 1:6

0 12  
Centimeters

A2 QUADRAT DATA AUGUST 1968

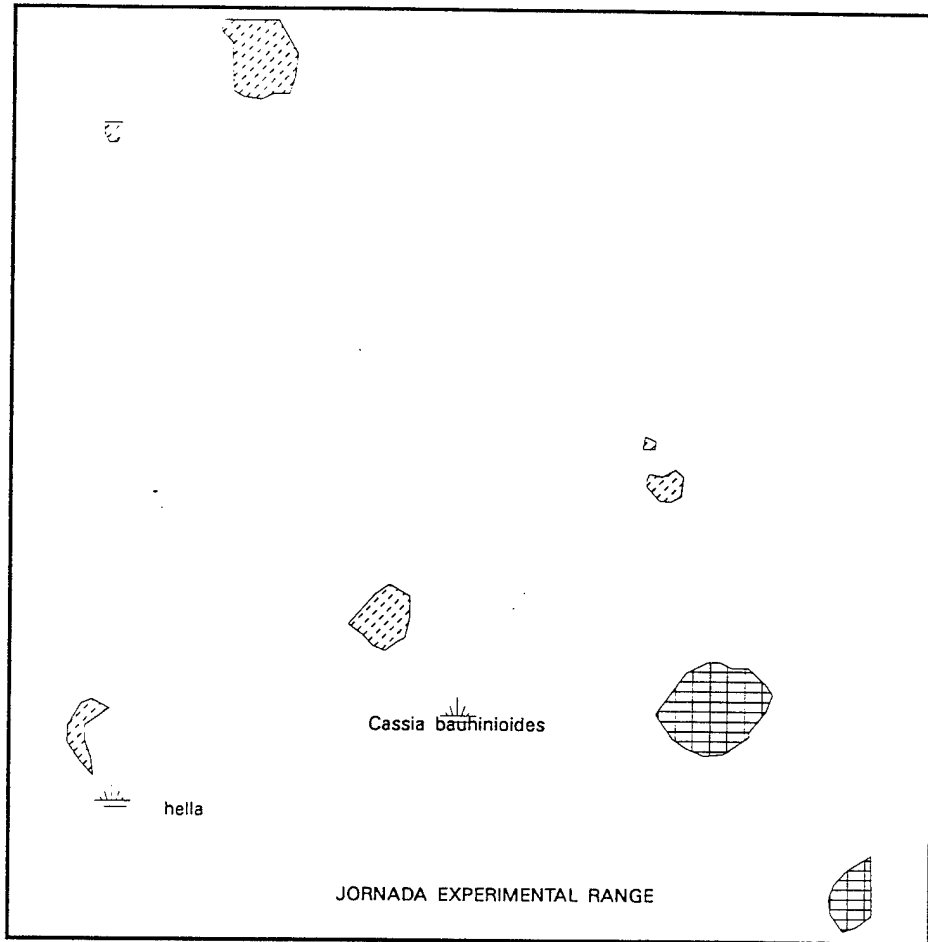

LEGEND



Dasyochloa pulchella



Sporobolus flexuosus



Stolen Representation



Shoots

Scale 1:6

0 12  
Centimeters



A3 QUADRAT DATA JULY 1977

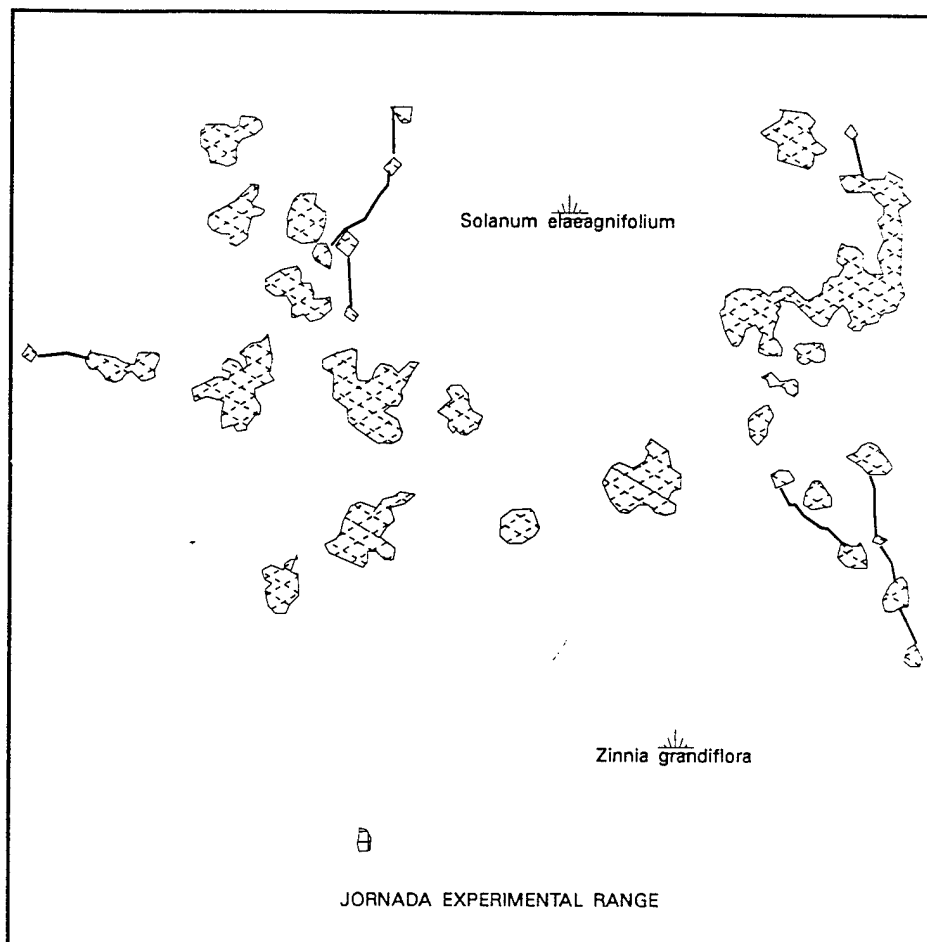

LEGEND

 Bouteloua eriopoda

 Sporobolus sp.

 Stolon Representation

 Shoots

Scale 1:6  
0 12  
Centimeters



A4 QUADRAT DATA AUGUST 1930

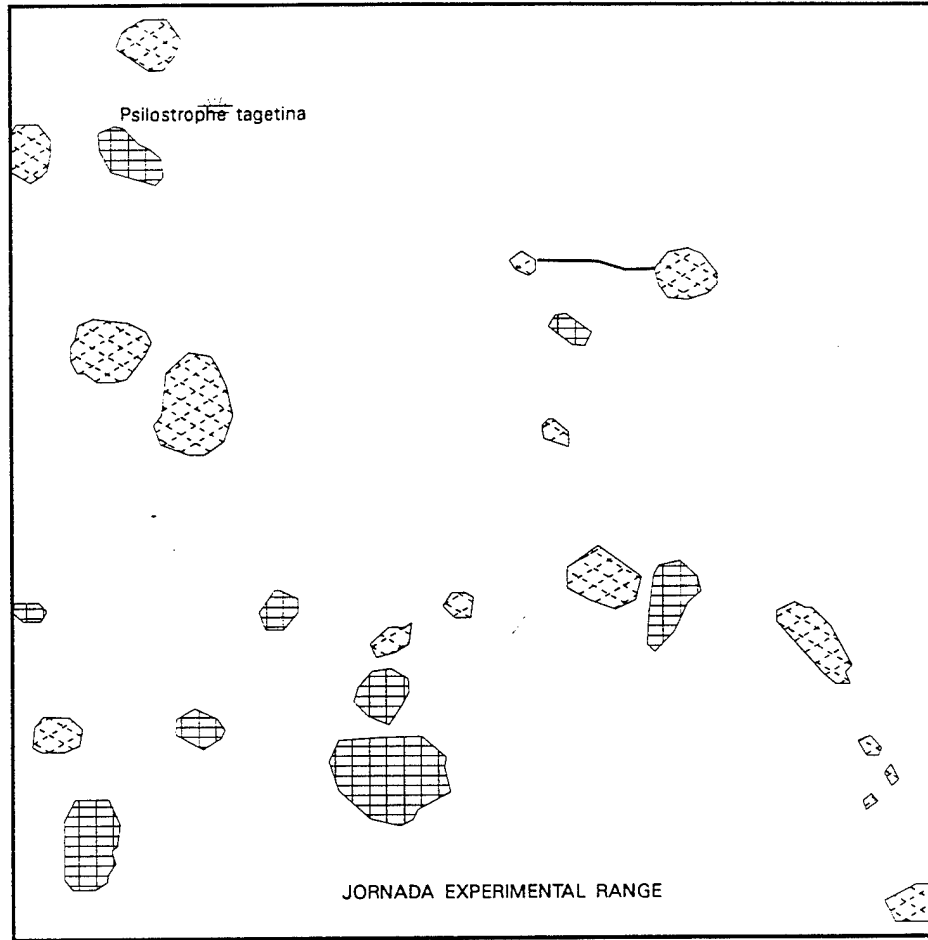

LEGEND



Bouteloua eriopoda



Sporobolus flexuosus



Stolen Representation



Shoots



Scale 1:6

0 12  
Centimeters

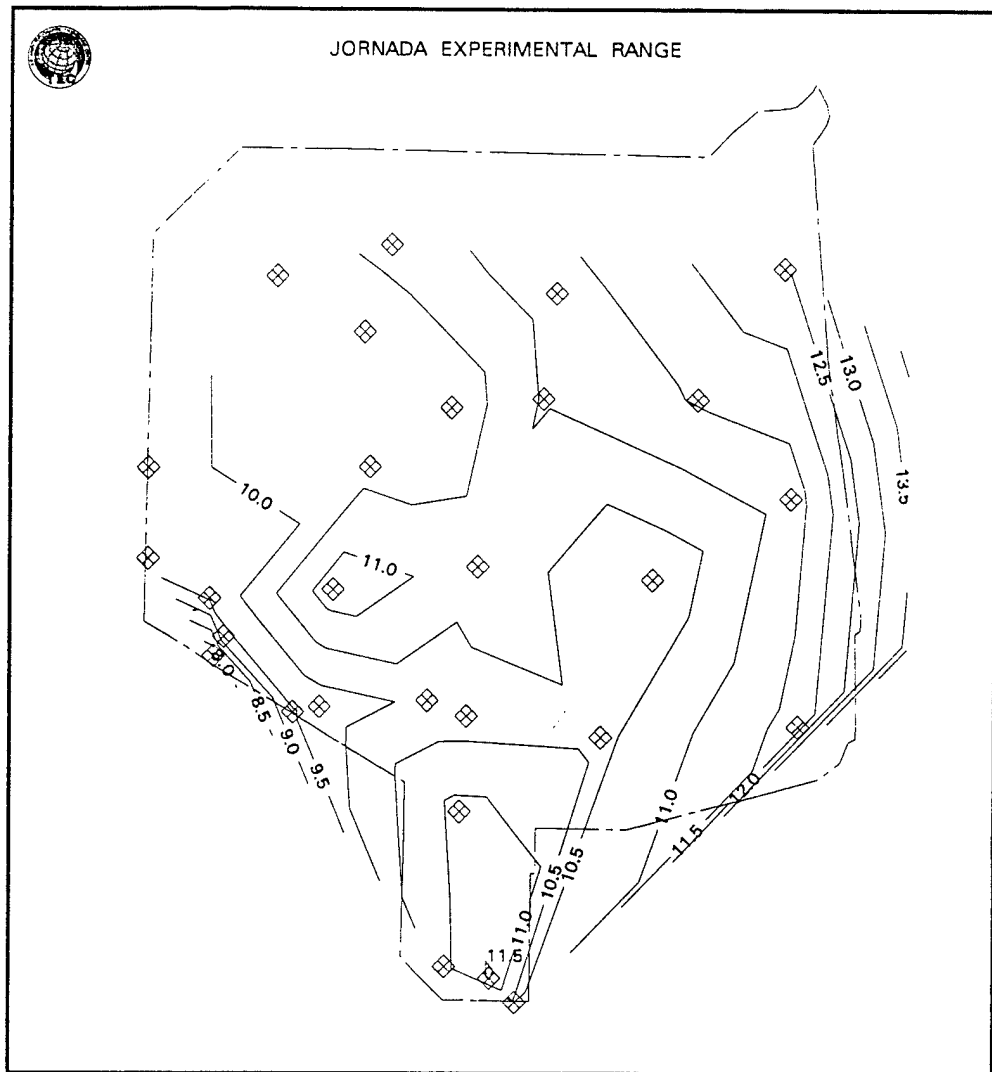
A5 QUADRAT DATA SEPTEMBER 1949



LEGEND

-  GAGING STATION
-  PRECIPITATION CONTOUR OF EQUAL INTERVAL, IN METERS
-  JORNADA EXPERIMENTAL RANGE BOUNDARY

Scale 1:200000



1965 - 1993 AVERAGE YEARLY TOTAL PRECIPITATION CONTOURS

### JER AVG ANNUAL PRECIP (1965-1993)

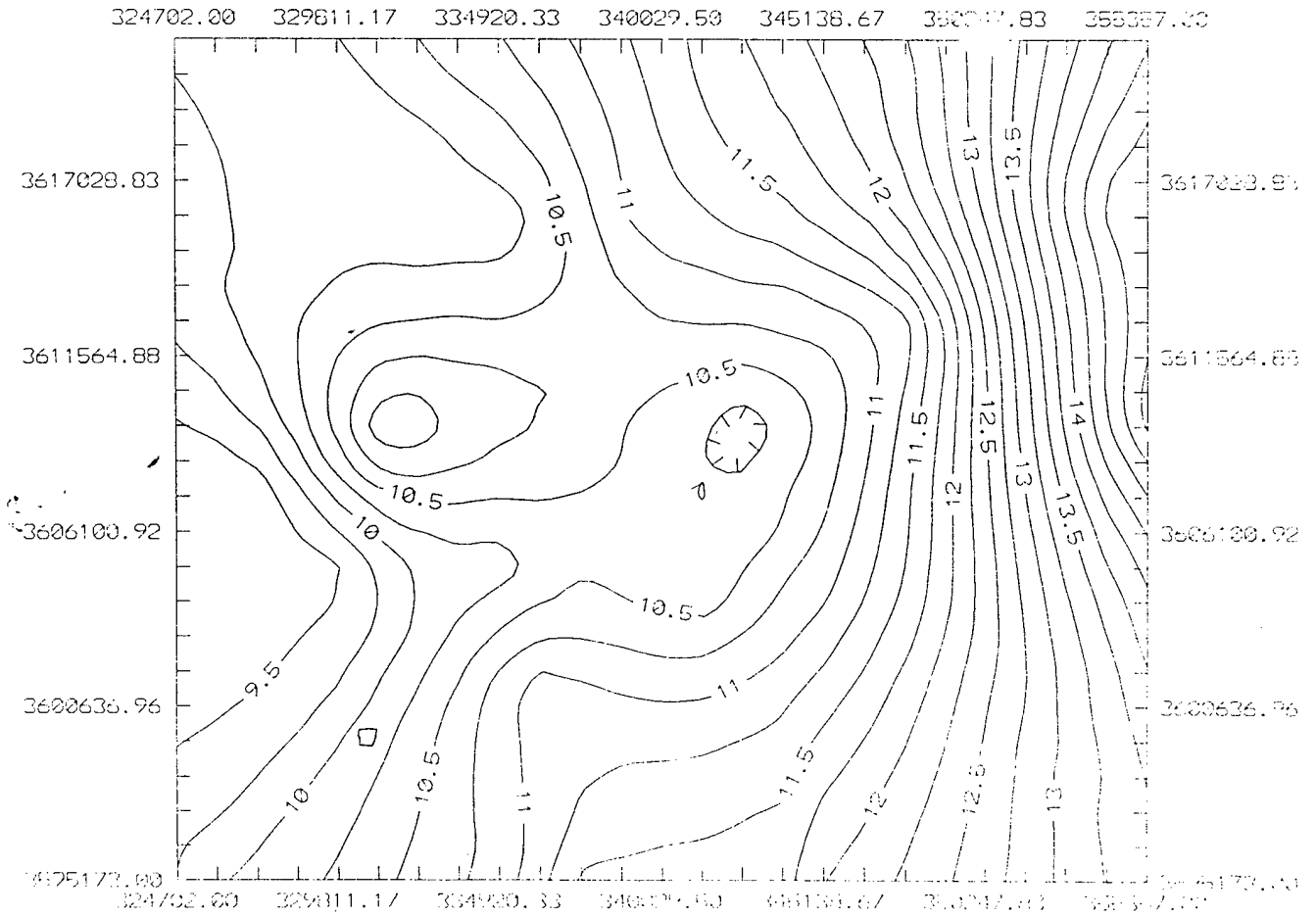



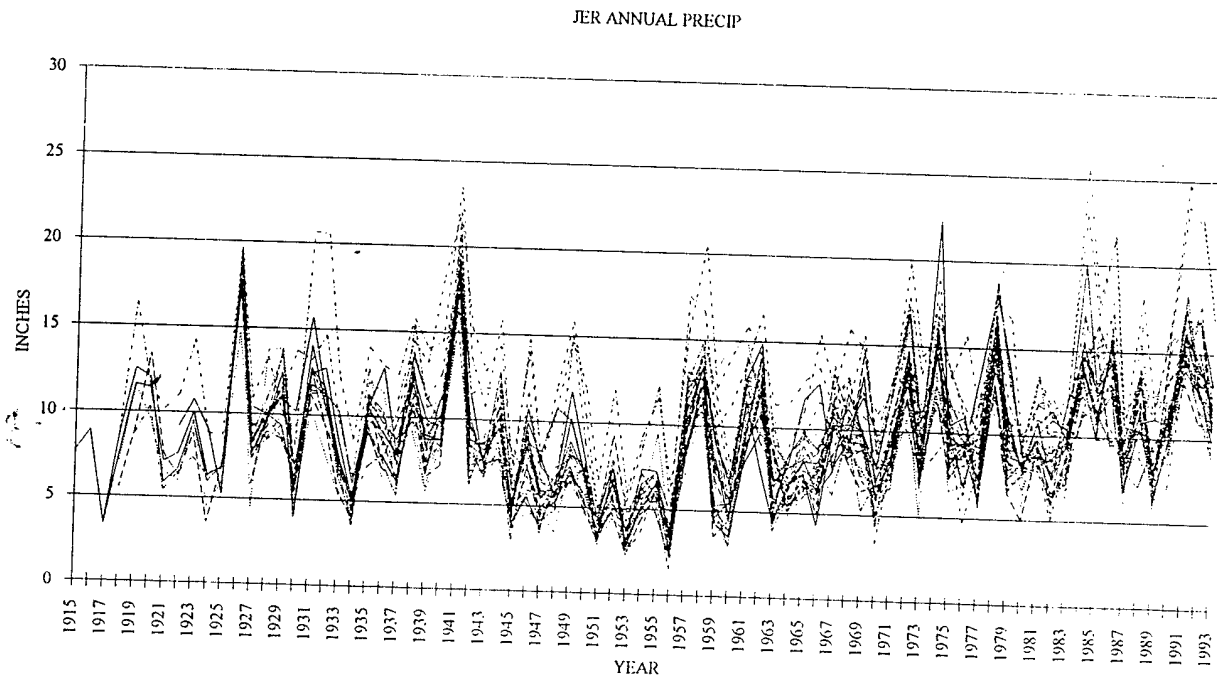

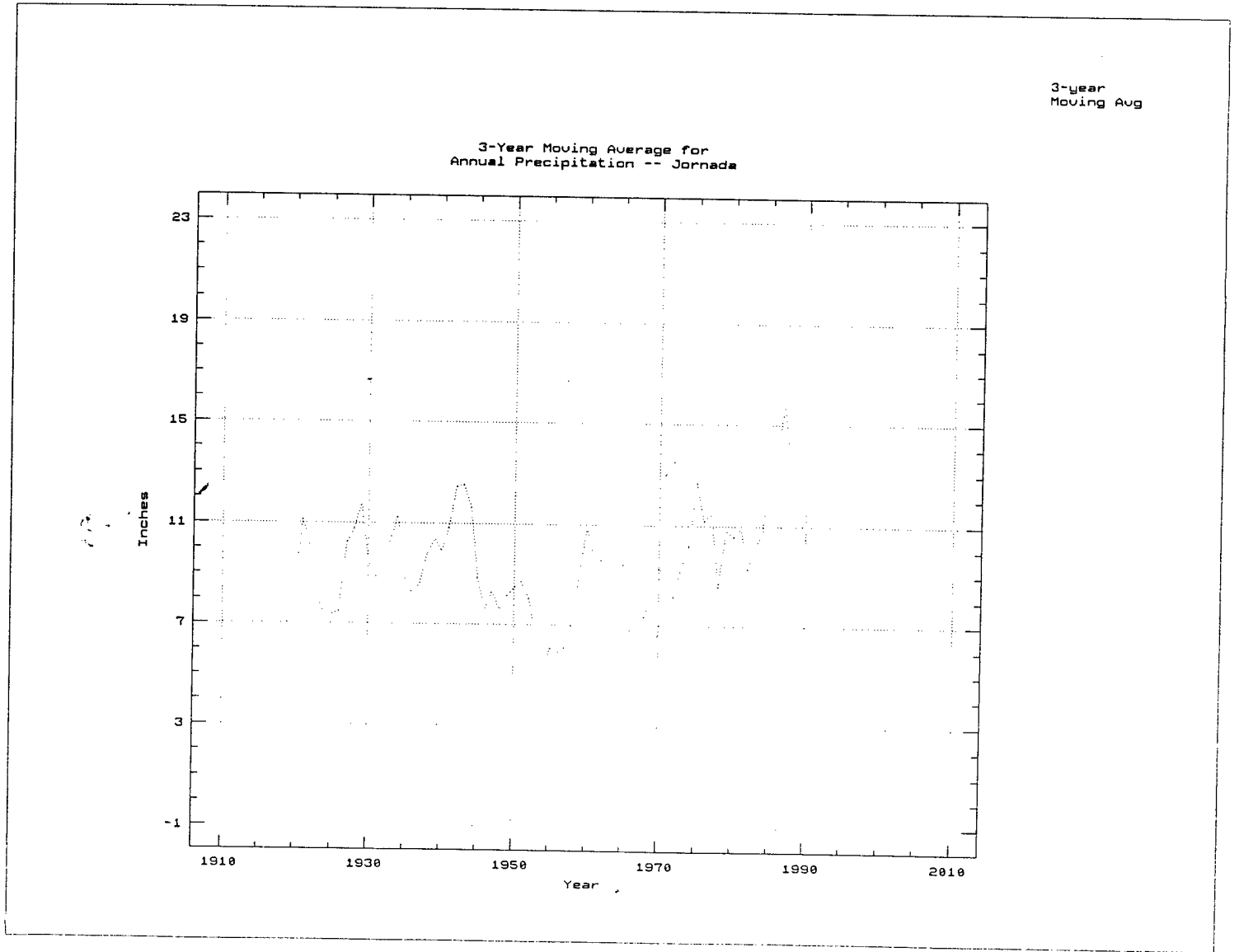

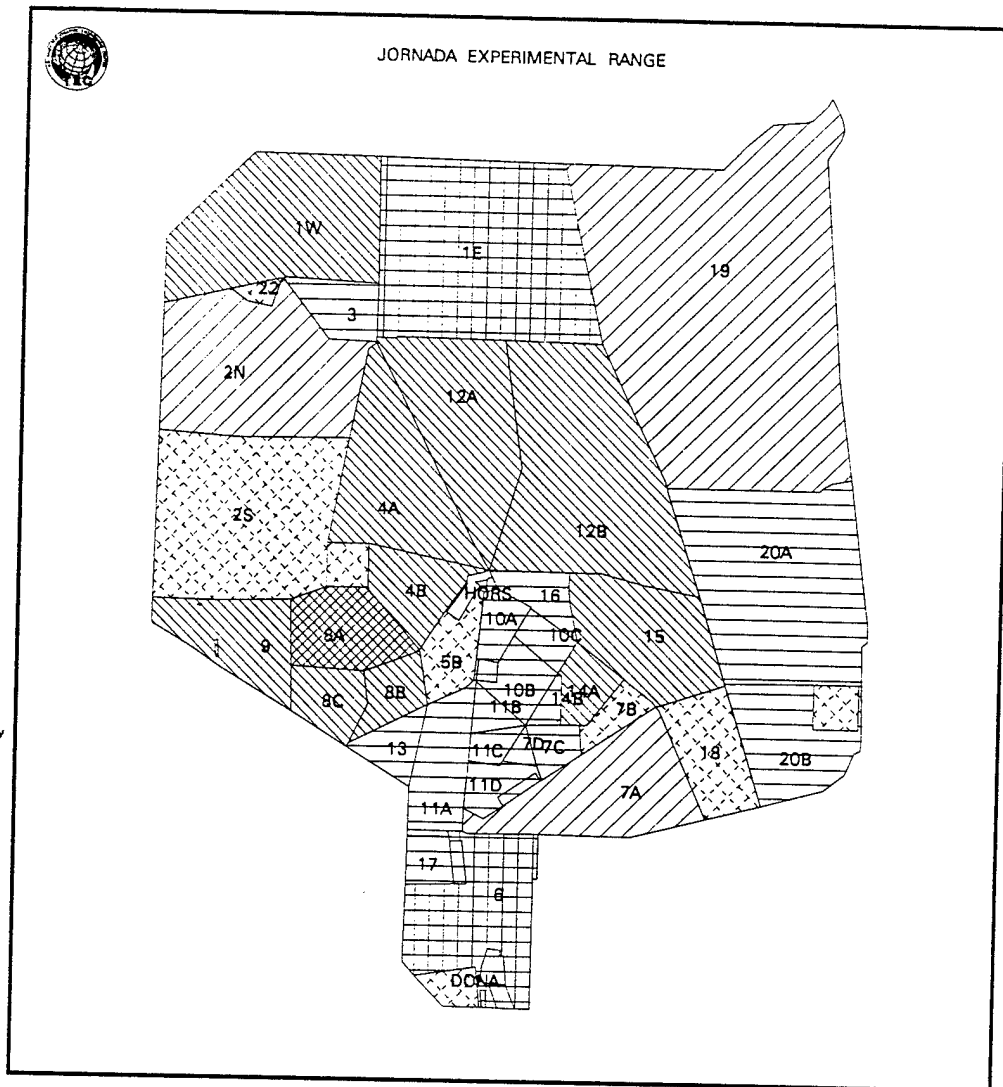
SHEET2.XLS Chart 2







LEGEND

-  0 ACRES / ANIMAL UNIT MONTH
-  1 - 10 ACRES / AUM
-  11 - 20 ACRES / AUM
-  21 - 30 ACRES / AUM
-  31 - 60 ACRES / AUM
-  61 - 170 ACRES / AUM

Scale 1:200000  
 0 4000  
 Meters

GRAZING INTENSITY ANNUAL TOTAL, 1993

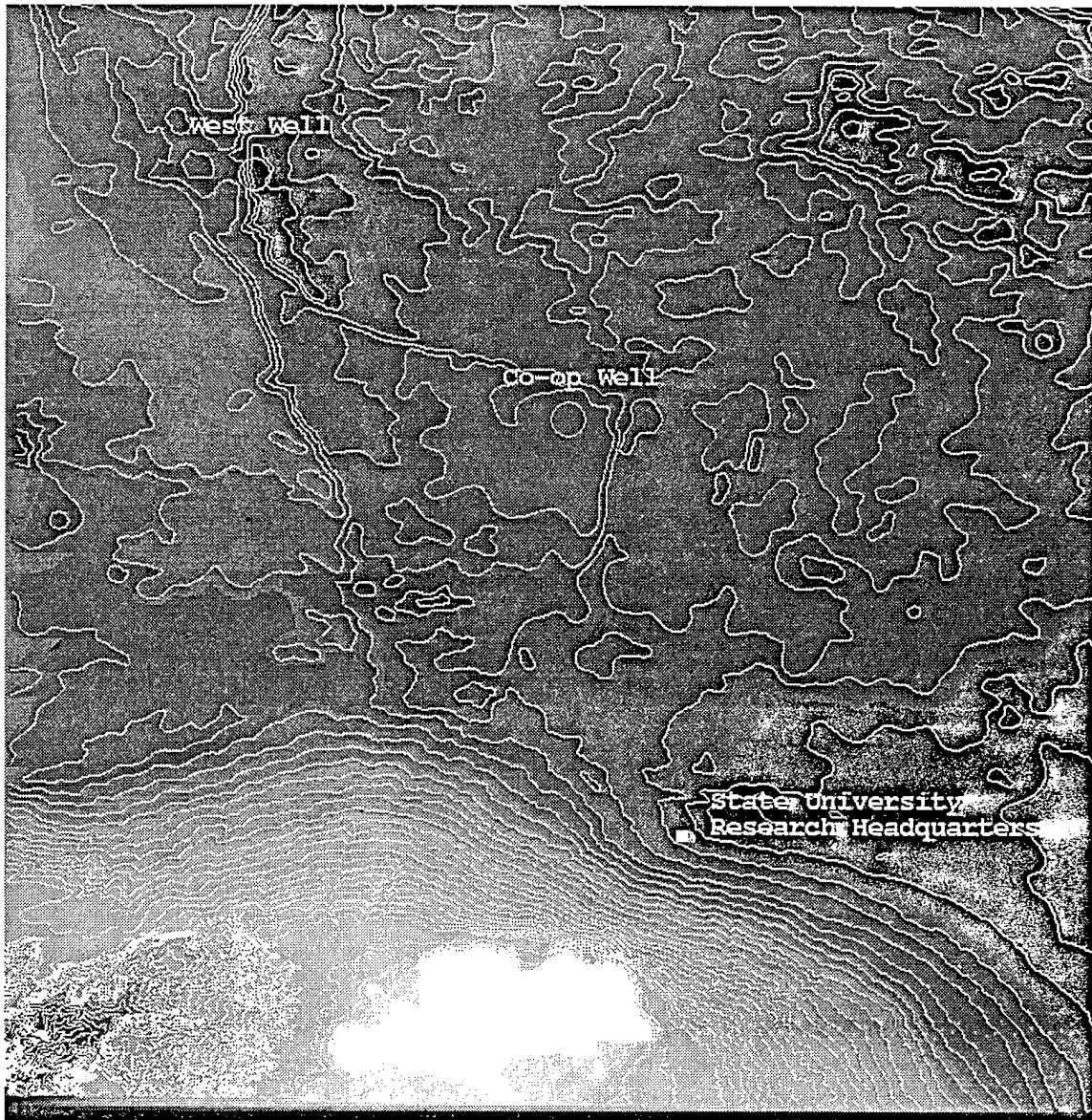

Summerford Mountain Topographic Quadrangle  
DEM Image

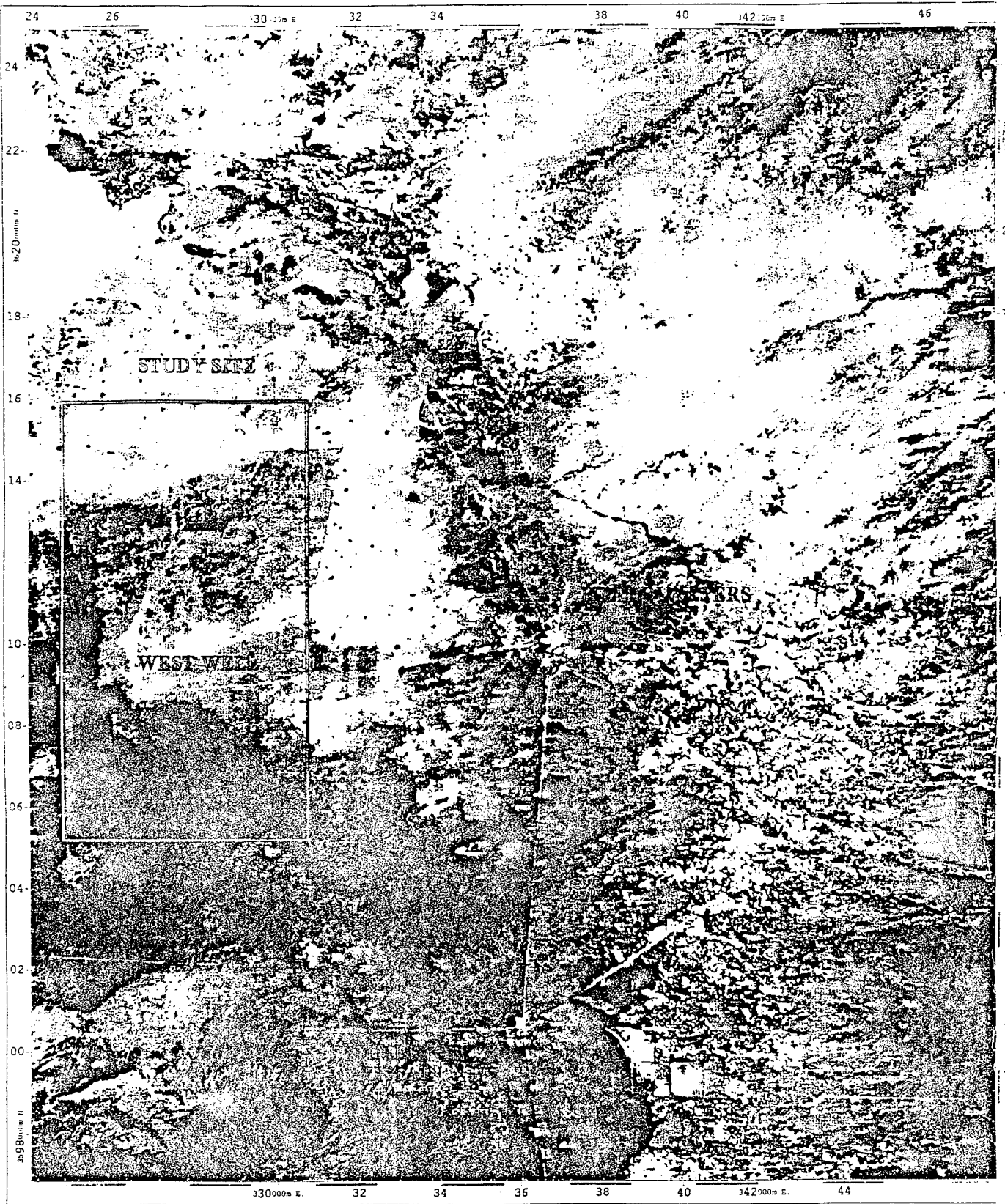

UNSUPERVISED CLASSIFICATION

9 June 1993 SPOTVIEW Imagery

1:100 000 Scale

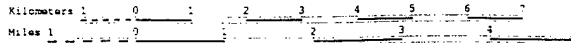

# LAND USE / LAND COVER MAP

## JORNADA EXPERIMENTAL RANGE

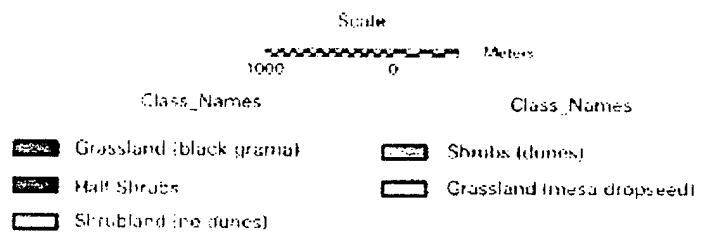
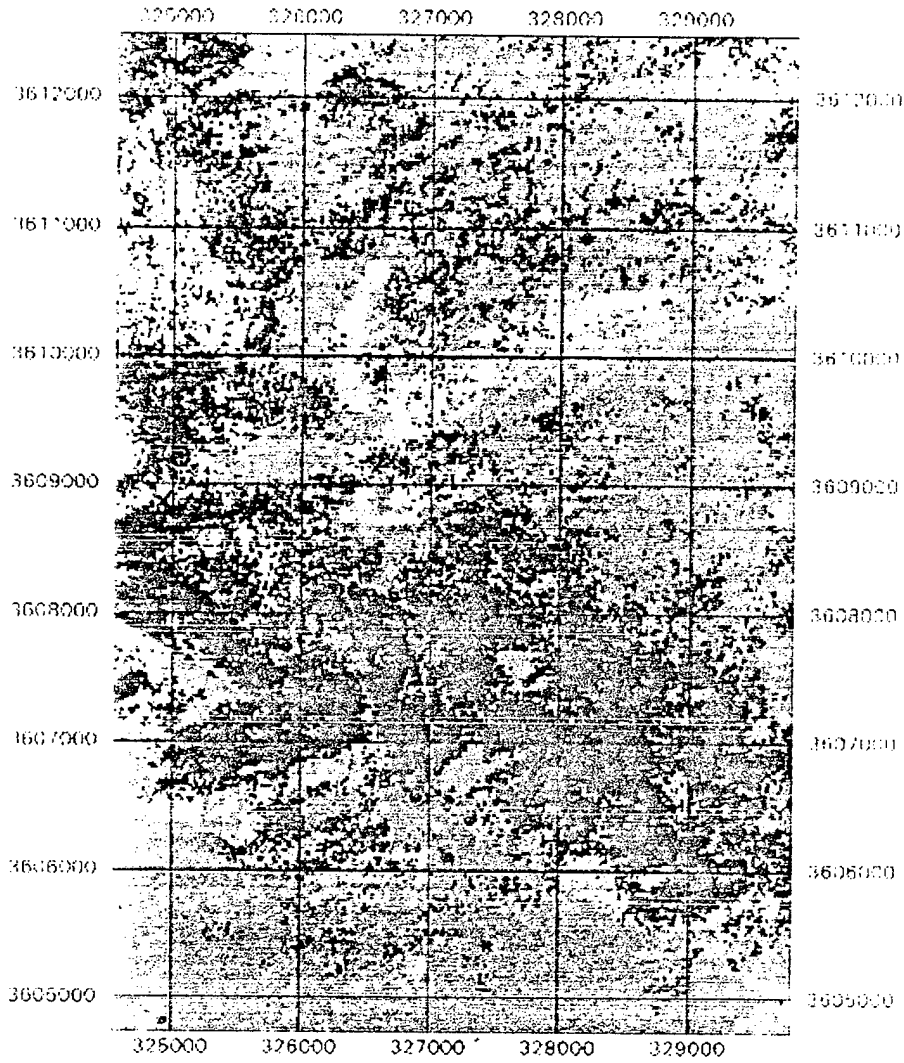

THIS PAGE INTENTIONALLY LEFT BLANK

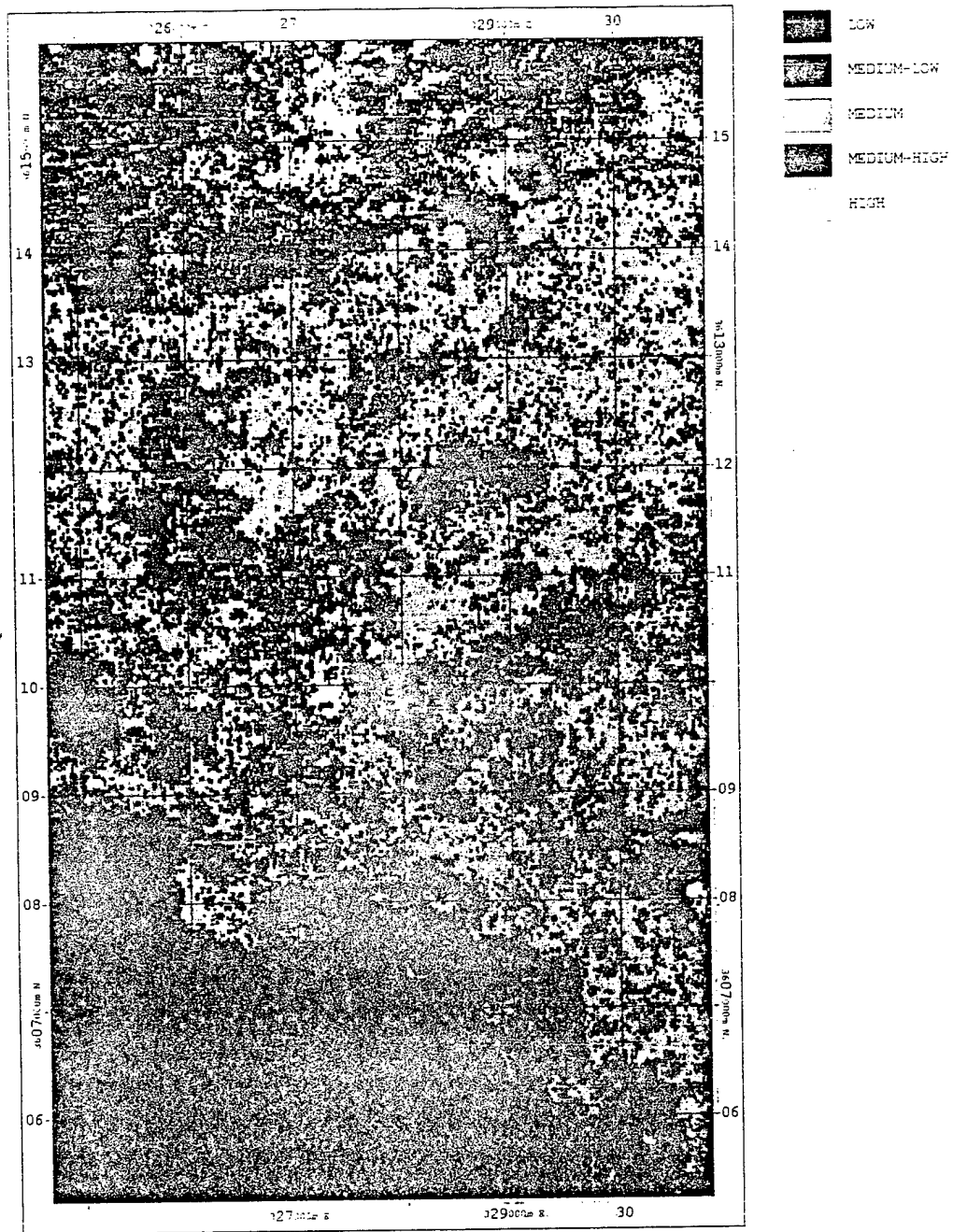

SOIL-ADJUSTED VEGETATION INDEX  
9 June 1993 SPOTVIEW Imagery

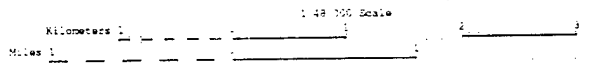

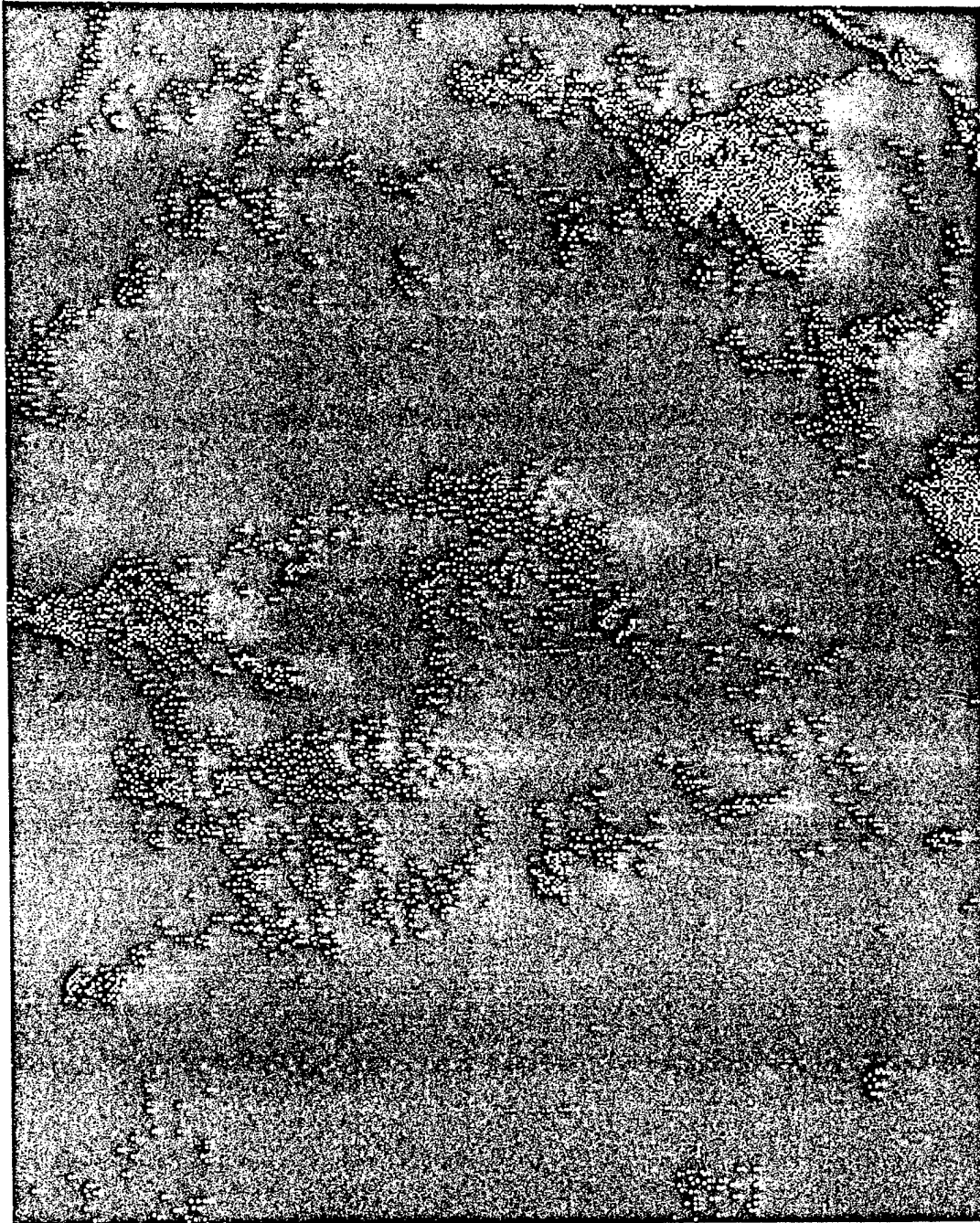

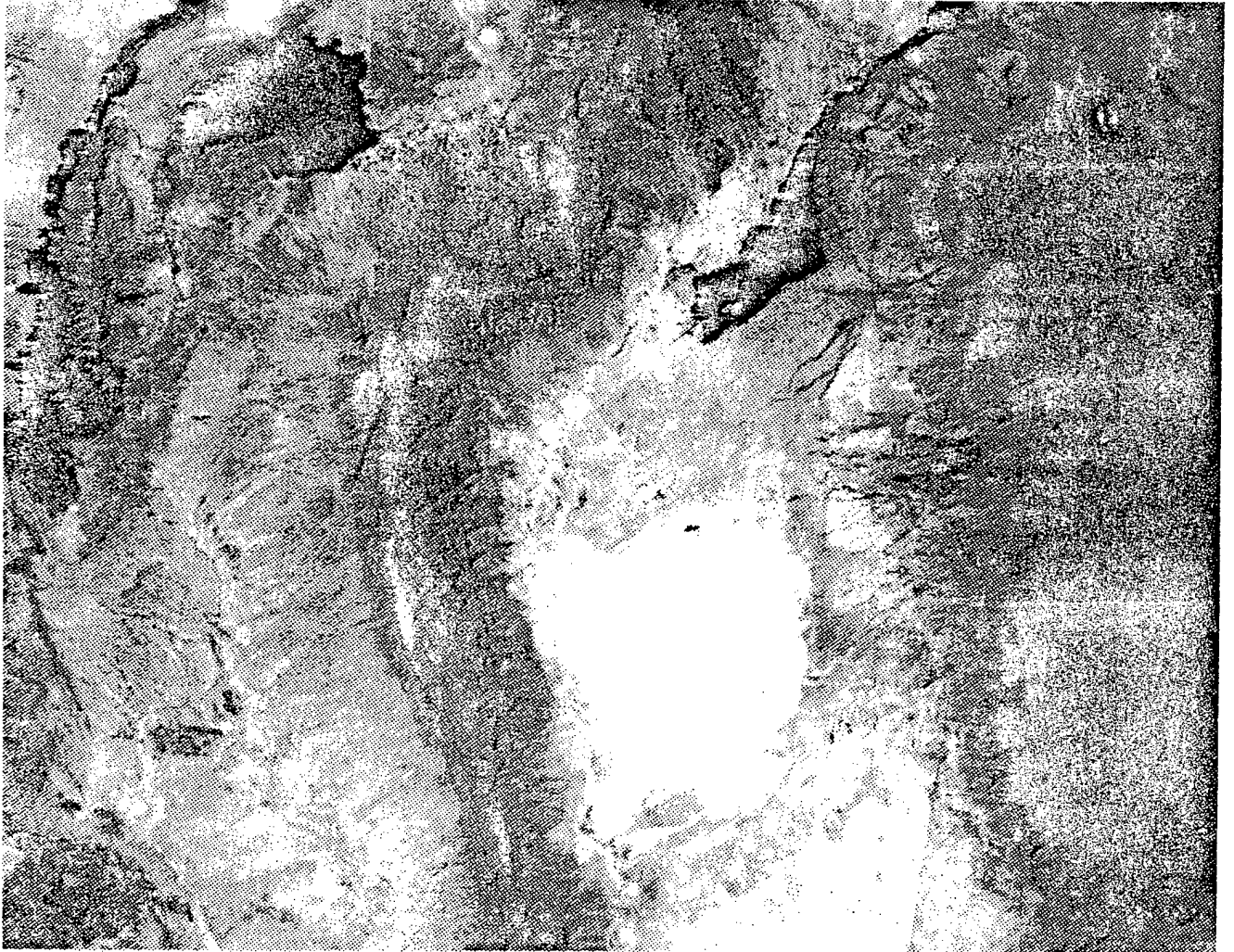

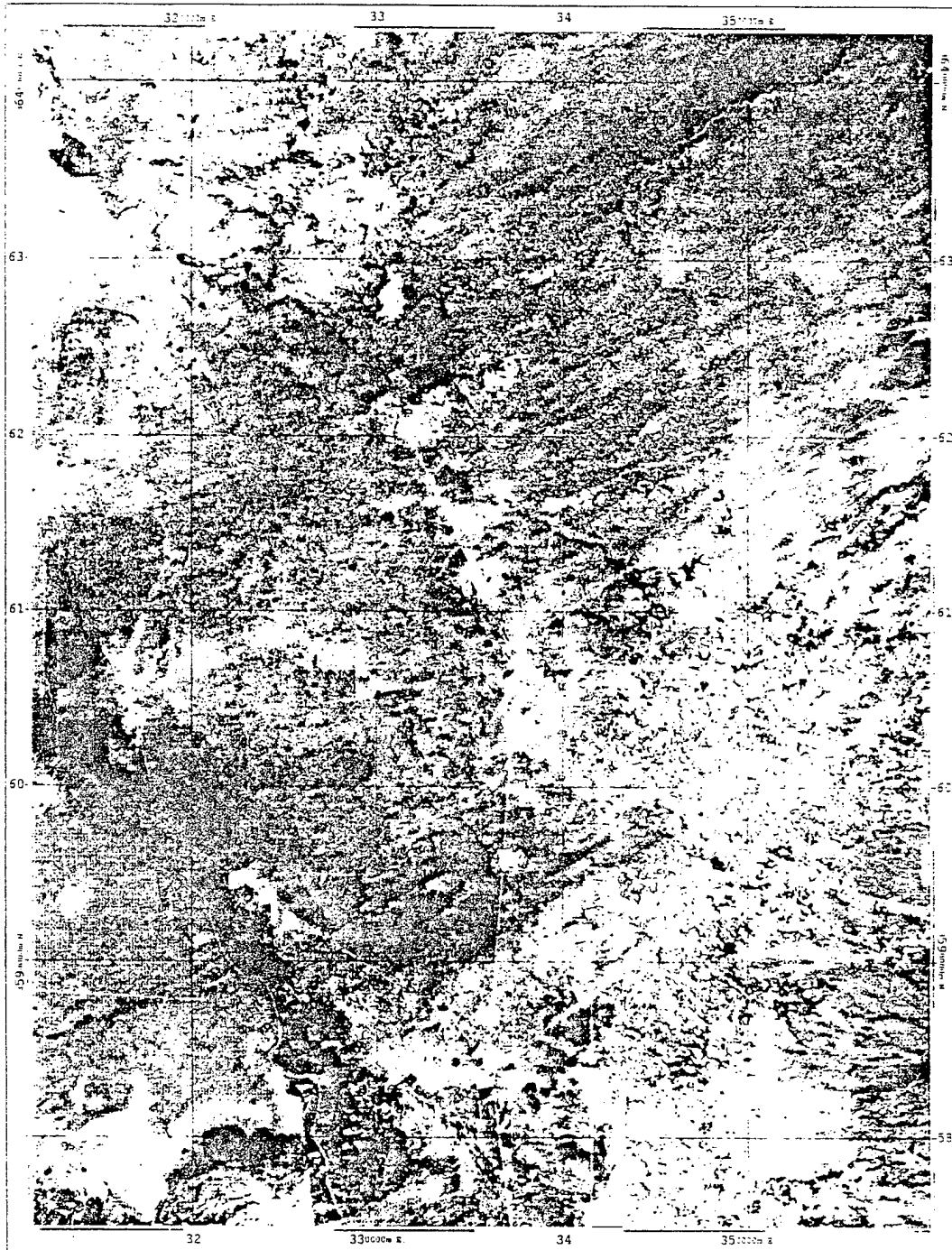

TM - SPOT PANCHROMATIC MERGE  
TM Bands 2, 3, 4 with SPOT Pan