

287023

JPRS 81630

25 August 1982

# Worldwide Report

TELECOMMUNICATIONS POLICY,  
RESEARCH AND DEVELOPMENT

No. 235

19980831 100

**DISTRIBUTION STATEMENT A**  
Approved for public release  
Distribution Unlimited

**FBIS**

FOREIGN BROADCAST INFORMATION SERVICE

REPRODUCED BY  
NATIONAL TECHNICAL  
INFORMATION SERVICE  
U.S. DEPARTMENT OF COMMERCE  
SPRINGFIELD, VA. 22161

6  
36  
A03

#### NOTE

JPRS publications contain information primarily from foreign newspapers, periodicals and books, but also from news agency transmissions and broadcasts. Materials from foreign-language sources are translated; those from English-language sources are transcribed or reprinted, with the original phrasing and other characteristics retained.

Headlines, editorial reports, and material enclosed in brackets [ ] are supplied by JPRS. Processing indicators such as [Text] or [Excerpt] in the first line of each item, or following the last line of a brief, indicate how the original information was processed. Where no processing indicator is given, the information was summarized or extracted.

Unfamiliar names rendered phonetically or transliterated are enclosed in parentheses. Words or names preceded by a question mark and enclosed in parentheses were not clear in the original but have been supplied as appropriate in context. Other unattributed parenthetical notes within the body of an item originate with the source. Times within items are as given by source.

The contents of this publication in no way represent the policies, views or attitudes of the U.S. Government.

#### PROCUREMENT OF PUBLICATIONS

JPRS publications may be ordered from the National Technical Information Service, Springfield, Virginia 22161. In ordering, it is recommended that the JPRS number, title, date and author, if applicable, of publication be cited.

Current JPRS publications are announced in Government Reports Announcements issued semi-monthly by the National Technical Information Service, and are listed in the Monthly Catalog of U.S. Government Publications issued by the Superintendent of Documents, U.S. Government Printing Office, Washington, D.C. 20402.

Correspondence pertaining to matters other than procurement may be addressed to Joint Publications Research Service, 1000 North Glebe Road, Arlington, Virginia 22201.

WORLDWIDE REPORT  
TELECOMMUNICATIONS POLICY, RESEARCH AND DEVELOPMENT

No. 235

CONTENTS

ASIA

AUSTRALIA

Companies Support Standardization of Data Networks  
(THE AUSTRALIAN, 29 Jun 82) ..... 1

NEW ZEALAND

Apple Accused of Dumping in Computer Offer to Schools  
(Various sources, various dates) ..... 3

Local Manufacturer's Complaint  
Customs Duty Required

'Dumping' Duty Imposed on Apple Computers for Schools  
(THE PRESS, 23 Jul 82) ..... 5

Government Ends Funding for Participation in Peacesat  
(THE EVENING POST, 17 Jul 82) . ..... 6

Briefs  
Satellite Receiving Station ..... 7

VIETNAM

More Telecommunications Facilities, Equipment Reported  
(QUAN DOI NHAN DAN, 1 Jul 82) ..... 8

LATIN AMERICA

ECUADOR

Shortage of Telecommunications Equipment Viewed  
(Napoleon Narvaez; EL COMERCIO, 13 Jul 82) ..... 9

JAMAICA

Minister Discusses Need for Local Communications Industry  
(THE DAILY GLEANER, 23 Jul 82) ..... 11

PARAGUAY

Briefs  
New Radio Stations 13  
New Mediumwave Station 13  
New TV Relay Station 13

NEAR EAST AND NORTH AFRICA

ISRAEL

Firms Emphasize Microelectronics R&D  
(Carol Novis; THE JERUSALEM POST, 29 Jul 82) ..... 14

SUB-SAHARAN AFRICA

MOZAMBIQUE

New Improved Public Telephones  
(NOTICIAS, 10 Jul 82) ..... 16

NIGERIA

Oyo State To Have Seven Television Stations  
(DAILY TIMES, 2 Aug 82) ..... 17

SOUTH AFRICA

Nationalists' Use of TV To Impose Own Views Hit  
(Editorial; RAND DAILY MAIL, 24 Jul 82) ..... 18

Briefs  
Johannesburg Television Transmitter 19

ZIMBABWE

Briefs  
GEC Telecommunications Tower 20

WEST EUROPE

INTERNATIONAL AFFAIRS

EEC Deliberates Further on IBM Monopoly Charge  
(Rex Malik; ZERO UN INFORMATIQUE HEBDO, 1 Jun 82) ..... 21

ITALY

Stressed Optical Fibers, Their Use as Polarizing Components  
(Valerio Annovazzi Lodi, Slivano Donati; ALTA FREQUENZA,  
May-Jun 82) ..... 24

## COMPANIES SUPPORT STANDARDIZATION OF DATA NETWORKS

Canberra THE AUSTRALIAN in English 29 Jun 82 p 17

[Text]

IN a major step towards open systems interconnection and networking between equipment supplied by different manufacturers, several major companies have announced their support for a set of local area network standards.

All these companies support the ISO (International Standards Organisation) transport protocol class 4 for the transport layer, which represents international standardisation of prior ECMA (European Computer Manufacturers Association) work.

For the lower layers they will support the new ECMA standard for the physical and data link layers.

The standardisation of these protocols will represent a major step to inter-vendor networking.

At the physical and data link layer these ECMA standards are largely compatible with Ethernet.

The interfacing of such local area networks with the public networks would usually be achieved through X.25.

It will be possible to integrate X.25 services into such local area networks.

The development of these standards, and continuing work within the ECMA community to define standards for networking, is seen as a precursor to international standardisation.

ICL was one of the first

companies to declare its support for the newly ratified ECMA standard for open systems local area networking.

Other companies supporting this initiative include CII-Honeywell Bull, Digital Equipment Corp, Fujitsu Ltd, Intel, Computer Technology Ltd, Office Technology Ltd, Network Technology Ltd, Logica, Mitel Corp, Mostek, Nixdorf, Olteco (Olivetti Telecomunicazioni SPA), Siemens, Three Rivers Corp, Ungermann-Bass, L.M. Ericsson, 3 Com, Hewlett-Packard and Xerox Corp.

Commenting on this development, ICL's managing director Mr Robb Wilmot said: "The rapid spread of networking, based firmly on standardisation, will mean an acceleration of the information technology industry and will provide an opportunity, particularly for British industry, to become more competitive and productive.

"ICL believes this announcement will be recognised in time as being as significant for information technology as canals and railways in their time proved critical to the growth of the economy by providing the essential infrastructure for effective communication."

The standard would provide a sound foundation for the development of integrated office systems.

The key characteristic of a local area network (or LAN) is that it generally operates

over short distances of up to 1.5km or so, to connect terminals of various kinds of one building, or a cluster of buildings on one site.

It has a wide band width and operates in broadcast mode, so that each device connected to the LAN sees all the messages in the network, but acts only upon those addressed to it.

Major advantages of the LAN are said to be high reliability, ease of operation and the ease with which additional devices can be attached.

LANs consist of coaxial cabling with simple methods of connection, allowing many different types of equipment to be connected.

According to ICL, the wide and varied number of suppliers of different computing equipment which have now accepted this standard means the user now has a new and far greater freedom of choice when purchasing equipment.

The announcement concerns two areas of standardisation of which the most important is the transport layer, now an ISO draft proposal, which provides a guaranteed end-to-end data transfer which is universal and which will work over any physical medium.

The link and physical layer standards use CSMA/CD

(carrier sense multiple access with collision detection) techniques approved by ECMA, and related to the physical medium being used, in this case base band coaxial cable.

It is the standardisation of the transport layer which is said to distinguish this new standard from existing Ethernet implementations.

A further reason for adopting this standard is the world-wide multi-discipline support which exists for it, according to ICL.

Through simple gateway devices, local area networks will be connected both to other LANs and to wide area networks (WANs), thus promising real open systems interconnection (OSI).

"The adoption of this standard opens the way to the development of networked systems," Mr Wilmot said.

"Users can plan with confidence, knowing that their investments in equipment can now be carried forward and fully protected.

"Using LANs, the expansion of systems will be easy.

"The range of choice open to users will be wider, both for small and large companies.

"ICL, for its part, is developing its products to implement the new standards."

## APPLE ACCUSED OF DUMPING IN COMPUTER OFFER TO SCHOOLS

## Local Manufacturer's Complaint

Auckland THE NEW ZEALAND HERALD in English 17 Jul 82 p 3

[Text]

About 300 of the 393 state and private secondary schools in New Zealand are expected to take up an American company's special offer of micro-computers.

But the offer is the subject of a Customs Department "dumping" inquiry, and fears have arisen that a virtual monopoly of the school market could mean higher prices for after-sales servicing and additional matching computer ware.

Yesterday, one week before the closing date for the six-week special offer by Apple Computer Incorporated, orders were flooding in at the rate of 15 a day. Now standing at 230, orders are expected to reach 300 by the end of the week.

## Complaint

The non-transferable offer means each school can buy one complete Apple II system for \$1200, a quarter of the normal price.

But Polycorps NZ Ltd has complained that Apple is "dumping" its computers — injuring a local industry unfairly by selling below market price.

If the complaint is upheld by the Customs Department, the Minister of Customs, Mr Templeton, is entitled to

charge a maximum import duty that would effectively lift the price of the micro-computers to market level.

Who would pay the duty is not clear, but the company and the schools would probably negotiate on it.

Further claims by Polycorps that the Apple II is soon to be superseded by a new system have been vigorously denied by Apple's New Zealand distributors.

## Competitive

The director of CED Distributors Ltd, Mr B. Eardley-Wilmot, said the Apple III was a more powerful up-market model that was not intended to supplant the Apple II. The Apple II was being continually improved and the company would not stop making them.

Meanwhile, the general secretary of the Post-Primary Teachers Association, Mr Bruce Webster, has publicly warned schools of the dangers of one company's cornering the market.

He said a contract supply agreement through the Government Stores Board would ensure pricing remained competitive, but a single special offer meant schools would be at the mercy of suppliers later on.

Apple's move, Mr Webster added, pre-empted an evaluation by the Education Department and the Computer Services Division of available microcomputer systems. The evaluation was due to begin in earnest on August 4 after information from more than 30 computer companies has been collated.

## No Govt Funds

The assistant secretary for schools and development, Mr Peter Brice, said the Government evaluation began in January with a listing of specifications required for school computers, and is expected to finish near the end of the year with a stamp of approval for one or more systems that matched those specifications.

The Minister of Education, Mr Wellington, has made it clear that no Government funds would be available "in the foreseeable future" for schools buying microcomputers, but the system recommended most suitable is expected to be made available through the Government Stores Board on a reduced contract rate.

About 200 schools have already bought one or more microcomputers of various brands.

## Customs Duty Required

Wellington THE EVENING POST in English 19 Jul 82 p 5

[Text] AN OFFER of quarter-price Apple computers to schools is commercial dumping, which should be liable for penalty duties, the Customs Department has decided.

The special low price and the injury this could cause to a local manufacturer, Polycorp, meant that the Apple offer was covered by anti-dumping regulations, an assistant controller of customs, Mr George Bathgate, said today.

The only question yet to be decided was the amount of duty which should be imposed.

The department would be recommending the duty to the Minister of Customs, Mr Allen, whose signature was needed to implement it, Mr Bathgate said.

A proposal by the Auckland distributor of Apples, CED Ltd, that the quarter-price offer be replaced by one of two computers for the price of one would also be investigated if it were made, he said.

Since the offer of \$1200 computers was made in mid-June, 271 schools have responded.

The offer would proceed, Mr Brian Eardley-Wilmott, a director of CED said today.

When the computers were imported from California, the schools would be given the option to pay the

duty. If they decided they did not want the Apple at the increased price, CED would pay the duty, take the machine off their hands and sell it through the regular marketplace, he said.

"It has taken a lot of hard work to negotiate with Apple to get this. We can't turn around to say to Apple that they can have these things back.

"We are endeavouring to show schools that they are in a no-risk situation.

"It really is a pity that Poly has done this because, regardless of the reasons for the offer, at least someone is trying to do something positive about computers in schools. But yet again the clobbering machine hits."

Mr Eardley-Wilmott felt the size of the duty would be a political decision, with schools lobbying to get it as low as possible.

The Apple offer had caused a complete halt to sales of Poly computers, the chairman of Polycorp, Mr Murray Smith, said. Until May sales had been pretty well on target.

From the start the Apple offer had been a very deliberate effort to undercut the local product.

The Poly was developed by Wellington Polytechnic and the Education Department. Polycorp is financed by the Development Finance Corporation and Progeni Ltd, a Lower Hutt software company.

Mr Smith said Polycorp was pleased that the Customs Department had accepted its case, "but on the other hand, it's something we didn't want to have to do."

"We hope that it doesn't cause schools embarrassment."

The Poly project was of extreme importance for the proper standardisation of computers in New Zealand schools, something which could only be done with a local company. It was also a top priority for the development of a local electronics industry, as recommended by the Industries Development Commission.

"We recognise that a backlash is likely, and it's something that could react to the disadvantage of Poly, but this whole thing has been caused by Apple. They have led the schools into this on a basis which was unfair, and did not give the full facts," Mr Smith said.

CSO: 5500/9033

'DUMPING' DUTY IMPOSED ON APPLE COMPUTERS FOR SCHOOLS

Christchurch THE PRESS in English 23 Jul 82 p 4

[Text]

PA Wellington  
More than 230 secondary schools which have taken up an offer of American-made Apple computers at \$1200 each — a quarter of their normal price — will now have to pay \$820 in dumping duty to get their machines.  
This comes after a directive by the Customs Department after a dumping complaint against the company.  
The Minister of Customs (Mr Allen) announced yesterday the provisional duty will be taken on any of the microcomputers landed in New Zealand from today.  
Mr Allen said the directive was not retrospective and would not apply to any of the microcomputers already in New Zealand.  
The dumping complaint came from a New Zealand educational computer manufacturer, Polycorp, which objected to the offer on the

ground that it was prejudicial to its marketing of the Poly machine.

Mr Allen did not reveal the amount of duty being applied, but Mr Brian Eardley-Wilmot, director of C.E.D. Distributors, Apple's New Zealand agents, said it was \$820.

He described the duty as "staggering."

Mr Eardley-Wilmot said schools which had taken up the offer would not be "locked in" to the agreement.

They were being written to and asked to confirm their purchase, with the extra \$820 added to the price tag.

Mr Allen said that his direction to secure dumping duty was provisional. It gives

Apple "an opportunity, should it wish, to offer further or updated information relating to its prices and the amount of dumping duty to be applied."

CSO: 5500/9035

## GOVERNMENT ENDS FUNDING FOR PARTICIPATION IN PEACESAT

Wellington THE EVENING POST in English 17 Jul 82 p 44

[Text] **Government funding for Wellington Polytechnic's participation in the Pan Pacific Education and Communication satellite experiment (Peacesat) has been stopped.**

Polytechnic council chairman Mr Martin Kimble said he had received a letter from the Minister of Education, Mr Wellington, telling him Peacesat's funding had been stopped as part of the Government's 3 percent cuts.

"I hope that it may still be possible to continue New Zealand participation in the satellite link," said Mr Wellington in his letter, received by the board at its meeting this week.

"However, now that Peacesat is providing a low-cost experimental communication network across the Pacific, I believe those availing themselves of the link could reasonably be expected to contribute to future running costs."

Wellington Polytechnic became part of the Peacesat network in 1971, operating with equipment set up by tutors and pupils from the school of physics, electronics telecommunications and electrical engineering.

### Below \$20,000

Polytech provided all the materials and equipment needed to establish the station and students set it up at no cost to the Polytech.

The Government's funding pays for the part-time employment of two people when the satellite is in operation, and money for the replacement of faulty parts.

Mr Kimble was unwilling today to disclose the actual amount, but said it was below \$20,000 a year.

The base is the only one in New Zealand, and is part of a network which now comprises 20 countries in the Pacific. The satellite — Applied Technology Satellite number 1 (ATSI) — is owned by the American space

agency, Nasa, and is in earth-stationary orbit above the equator and close to Christmas Island.

Its placement enables coverage of most of the United States and the Pacific.

The network operates for 21 hours a week, and provides the means for a number of groups, including scientists, teachers and religious groups, to exchange ideas and information.

Mr Kimble, who is president of the network's governing body, the Peacesat Consortium, said it was a shame Government had stopped its funding.

### Host country

He said the Polytech station could be maintained for a few months using what was left from last year's funding, but long-term funding would have to be found.

If it could not be, New Zealand might be losing an important link with other countries.

"We have to think about the fact that New Zealand is the host country for very large numbers of people from the Polynesian areas," he said.

"We are providing dialogue with their home countries, and assisting in the understanding of their cultures. A lot of that will certainly disappear if Peacesat can't continue."

The Minister of Science and Technology, Dr Ian Shearer, announced recently the Peacesat network would be used in a new agricultural exchange project between Asian and Pacific countries.

### Discuss it

Mr Kimble has written to Dr Shearer, telling him that Peacesat may not be able to continue.

"I have suggested that he discuss it with the Minister of Education," said Mr Kimble.

The Wellington Polytechnic Council has asked Mr Kimble to continue with his efforts to keep the Polytech station in operation.

## BRIEFS

SATELLITE RECEIVING STATION--Wellington (PA)--The Minister of Science and Technology (Dr Shearer) wants the Government to consider investment in a satellite receiving station. After meeting representatives of the European Space Agency yesterday, he said he planned to ask the Communications Advisory Council to prepare a separate report on such a station, or to include its conclusions in a report it is preparing on satellites in general. Dr Shearer spoke after attending a seminar at the Department of Scientific and Industrial Research at Gracefield, Hutt Valley, held by two representatives of the E.S.A., on its oceanic remote sensing satellite. "Data from this satellite would give us a better idea of the fish resources in our waters," Dr Shearer said. He was told that a basic price for a receiving station in New Zealand could be about \$8 million, with running costs about \$650,000 a year, plus a further \$600,000 for a memorandum of understanding. [Text] [Christchurch THE PRESS in English 17 Jul 82 p 1]

CSO: 5500/9034

## MORE TELECOMMUNICATIONS FACILITIES, EQUIPMENT REPORTED

Hanoi QUAN DOI NHAN DAN in Vietnamese 1 Jul 82 p 1

[Article: "The Telecommunications Sector Increases Communications Equipment and Facilities"]

[Text] In the first half of this year, the telecommunications sector placed additional items of equipment and facilities into use and improved a number of those already available, heightening the capacity of the communications network.

Each part of axis 1A line has been immediately placed into use upon completion. Recently 66 communications channels linking Hanoi and Da Nang have been tested, accepted, and placed into operation; lines 2 and 3 are being installed and equipment is being assembled for a number of technical stations [tram co vu] from Da Nang southward. The copper cable project of the Hanoi-Hai Phong axis is at the stage of building the Hai Duong cable protection house [nha bao ve cap] and the Hai Phong technical house [nha co vu].

Telecommunications units have utilized many kinds of material supplies and items of equipment that was in storage, restored much old equipment, and placed it into use to serve the communications network. In the first half of this year, lines of the cable network were extended, and the number of carrier wave telephones, microwave equipment, and standard telephones increased by 2.5 to 13.7 percent. Twenty seven provinces and cities have been able to communicate directly with central organs without having to go through other telecommunications operators or requiring the combination of many telecommunications modes. Quang Ninh, whose microwave system feeds into the Hanoi-Haiphong line, is able to communicate directly with Hanoi. Communications lines with Laos (via satellite) and with Phnom Penh (via microwave) have been basically established. The communications line linking Ho Chi Minh City with Moscow (Soviet Union) has developed its action of serving oil and gas survey and provides the communication link between Cambodia and the Soviet Union.

With the use of containers, postal matters and parcel posts destined to various countries are transported and managed more favorably than before.

8418

CSO: 5500/5864

SHORTAGE OF TELECOMMUNICATIONS EQUIPMENT VIEWED

Quito EL COMERCIO in Spanish 13 Jul 82 p A-8

[Article by Napoleon Narvaez]

[Text] Quito and the rest of the country are suffering a disturbing shortage of telephone lines. The growth of the cities requires urgently the expansion of this means of communication, but to meet this requirement, an investment of more than 20 billion sucres, one-third of the national budget, is needed. This is an expenditure which the national economy is not in a position to meet, at least at present.

The capital has now about 100,000 electromechanical dial telephone lines and needs more than 300,000. The applications for telephones are in the hundreds, especially in condominium residences built in business and residential sections where in the past there were single-story houses.

According to official announcements, it will take at least 5 years to meet the requirements at the national level and especially in Guayaquil and Quito. This is due to the need to acquire technology and equipment. According to Ecuadorean Telecommunications Institute [IETEL] experts, this will call for bids for equipment for telephone exchanges, transmitters, cables for building the network and TELEX exchanges. All of this has been delayed, first because of the difficult administrative procedures and second the lack of money. According to information supplied by the government, steps have already been taken for calls for bids for 1980-1984.

However, in spite of the lack of resources, IETEL's First Regional Office is carrying out several projects. In the rural area, it has installed exchanges at Tena, Puyo, Coca and Lago Agrio. Similar exchanges have been set up in Tabacundo, Quinche, Guayllabamba, Pido, Puenbo, Salcedo, Alausi and El Carmen. All have a maximum capacity of 250 lines and are linked to the national network and the customer can speak with any other point in the country and abroad.

In the absence of financing, it is hoped that the objectives of the 5-year tele-communications plan can be achieved by acquiring 25,600 central telephone lines with electromechanical technology in order to expand, using as a base existing equipment, the exchanges of Ibarra, Esmeraldas, San Rafael, Cumbaya, Latacunga, Guayaquil, Quevedo, Milagro, Libertad, Portoviejo, Machala, Loja and Huaquillas.

They are also planning to acquire 73,500 digital-controlled local lines for Quito, Guayaquil and Bolivar Province. For their operation, 18,000 exchange lines will be bought for traffic with Quito, Guayaquil and Cuenca. They will also buy 19,000 exchange lines for the capital and the port, equipment for the operations center and for maintenance, administration and management activity in these cities.

It was explained that so-called "poor telephone service" is caused by the insufficient capacity of the lines, long telephone conversations, the insistence on getting a line, often without taking into account the saturation of the calls in relation to the capacity of the telephone equipment and/or the complexity of service, involving extensive networks connecting the telephones through thousands of very small cable and sophisticated equipment.

Nelson Herreria, manager of Region One, promised for INTEL that the service will be improved. He announced that U.S. \$12 million will be invested in new equipment and in the enlargement of exchanges to improve service and prevent the saturation caused by the customers who unknowingly cause congestion. The improvement of the service will be completed between 1982 and 1983. The experts explained that this new equipment does not mean that more lines will be available.

Two electronic exchanges will be bought for the TELEX, GENTEX and DATEX services with a minimum capacity of 3,100 TELEX customers and 900 trunk lines and 50 customers in the DATEX system. These exchanges will be set up in Quito and Quayaquil and they will be complemented by other equipment which will make the system operational at the national level.

To improve Quito's telephone service, IETEL will open up the pavement in many sections to install the primary and secondary networks. It was said that this is to install a technologically improved system. The country is served by 275,000 telephone lines and requires twice that capacity.

Finally, IETEL reported that the country has 28,000 direct dial telephone lines which are located as follows: 2,000 in Tulcan, 3,000 in Ibarra, 2,000 in Cotopaxi, 10,000 in Tungurahua, 6,000 in Chimborazo, the only province which has digital telephones. Bolivar, with 1,000 lines, is a province which has not yet been incorporated into the direct dialing system.

To summarize: in 1981 IETEL had an income of 1,052,000,000 sucres and spent 778 million. It needs adequate financing to carry out a new telecommunications program to have good technical service which is modern and sophisticated and will satisfy the customers.

9204

CSO: 5500/2309

## MINISTER DISCUSSES NEED FOR LOCAL COMMUNICATIONS INDUSTRY

Kingston THE DAILY GLEANER in English 23 Jul 82 p 20

[Text]

**THE MINISTER OF STATE** for Information, the Hon. Mike Henry, has said that the country must begin to lay the foundation for a communications industry, so that both the private and public media can become self-supporting as well as forming an important sector of the industrial community.

Speaking in the sectoral debate on July 14, Mr. Henry said that the country must search for the most scientific and objective forms of information. This meant that the printed word, radio and television programmes, films and audiovisual products must be seriously examined.

Mr. Henry continued: "Added to this, we must begin to lay the foundation for a communications industry, so that not only will the media — both private and public be self-supporting, but they will form an important sector of the industrial community, turning our products which we must now import, as well as exporting specially prepared products.

He said that the communications industry would

require creativity and production.

With regards to the financial aspect, he said it should not be assumed that it is only the government who must spend money in this area.

**HIGH RISK**

He said investment in communications was still regarded as a high risk venture in Jamaica, but it was the most profitable area of speculation for the future.

Speaking on the Information portfolio, Mr. Henry said that the Ministry was putting together a three-pronged programme for the training of Government media personnel to meet immediate needs as well as short and long-term needs.

In this respect, he said the Ministry has already had discussions with representatives of the College of Arts, Science and Technology (CAST) and the University of the West Indies (UWI), as well as representatives of the media:

"We hope that the private media will also place training among their priorities," Mr. Henry said. "We cannot continue stealing staff from each other. We must advance in a coherent and planned fashion. We

must open the world to our creative ability." He said in most national information policies today, audience evaluation, including scientific analysis, marketing surveys and feed-back, is prominently featured.

**HE SAID HIS MINISTRY** has already been involved with two surveys: one through the Jamaica Broadcasting Corporation (JBC) which was a marketing survey, and a second experimental in-depth survey of television viewing for the proposed second television channel.

Mr. Henry said the Ministry was about to commission three more studies, which would keep it abreast of what the information needs were and what Jamaicans feel about the media. Based on such studies the Ministry will make policy — using the latest methods.

**NEW JIS**

Mr. Henry said that an advisory committee is to be named soon to finalize the plans for the reorganization of the Jamaica Information Service.

The committee will be comprised of communications specialists, technicians and bureaucrats who will ensure the most

professional plan of action, as well as a smooth transition for the JIS.

He said it took the government more than the entire first year of its administration to clean up most of the mess which it had inherited at the JIS.

He said the foreign exchange situation was still a major problem in getting the JIS properly equipped to meet current demands.

Some new tape recorders have been put in, new vehicles bought but the service was still behind in the acquisition of television cameras and recorders, colour equipment, portable projectors, film making equipment, photographic equipment and sound machines.

The film unit was only capable of producing eight 10-minute films and three half-hour films annually. Another problem was the rapid turnover of Information Officers.

CSO: 5500/7555

## BRIEFS

NEW RADIO STATIONS--The executive branch has canceled the license granted to Mr Hilarion Antonio Correa to operate radio station "Radiodifusoras Caaguazu" on both medium wave and FM frequencies with the call signs ZP 19 and ZPV 19, respectively. Instead, Mrs Francisca Lujan Vda. De Correa has been authorized to install and to operate two radio stations in the city of Coronel Oviedo: one of medium wave on 1570 khz whose transmitter will not exceed 1 kw; and another FM station on the 101.7 frequency whose transmitter will not exceed 5 kw. [Asuncion HOY in Spanish 3 May 82 p 10 PY]

NEW MEDIUMWAVE STATION--By Decree No 33,863, the executive branch has authorized the national cement industry to install and to operate a medium-wave radio station in Vallemi Port. The station, which will be named ZP29 Radio Vallemi, will broadcast on 650 khz and its transmitting power will not exceed 5 kw. The license will have to be renewed every year. [Asuncion HOY in Spanish 16 Jun 82 p 10 PY]

NEW TV RELAY STATION--The executive branch yesterday authorized Teledifusora Paraguaya Inc. to install and to operate a TV relay station in the city of Pedro Juan Caballero. The station, which will be called Channel 9 Teledifusora Paraguaya Inc., will transmit with a 1-kw power and should be on the air within 8 months from the date of the authorization. [Asuncion HOY in Spanish 7 Jul 82 p 10 PY]

CSO: 5500/2321

## FIRMS EMPHASIZE MICROELECTRONICS R&amp;D

Jerusalem THE JERUSALEM POST in English 29 Jul 82 Supplement p 12

[Article by Carol Novis]

[Text]

THE DEVELOPMENT of micro-processors and electronic digital equipment has had a revolutionary effect on the telecommunications industry throughout the world. And Israeli firms have managed not only to keep up with new developments, but also to create their own profitable niche in world markets.

Telrad, a Koor subsidiary, is one Israeli company which has achieved the transition from electro-mechanical telephone equipment to fully automated telecommunications systems, in the process raising exports from \$1 million in 1978 to \$15 million in 1981 on an annual turnover of \$65 million. This year's export target is \$20 million.

A strong R&D force of 110 employees and an expenditure of 7 per cent of revenues on R&D is one reason the firm gives for its achievements. Says head of the development branch David Raveh: "We can compete with anyone, even the Japanese."

Telrad channels its development activities in two main areas: adaptation and redesign of products for which rights have been acquired abroad, and original development of their own designs.

One of the firm's key products, worked on intensively since 1979, is their Key bx total telephone system, which has achieved substantial sales success. This electronic telephone system has over 20 special features. For example, you can dial with the receiver on the hook, you can store

frequently used numbers and speed dial them. Then you can hold a five-party conference call, and activate a do-not-disturb function which transfers calls automatically to another station.

When a line is busy, the speaker can be informed of a waiting outside call, and other stations can call through the loudspeaker while a telephone conversation is in progress.

The optional digital display on each instrument — a first in the field — shows the time, elapsed time call, call-back station number, busy lines and the number dialed. Research for the Key BX project was sponsored by the American Israel Foundation.

Since the system was introduced, a number of variations have been made available, according to needs of individual customers, such as an extension of the number of trunk lines.

Telrad also manufactures a versatile public-line digital exchange system with up to 5,000 lines. This can transmit voice and data simultaneously on the same line by means of electronically coded digital pulses.

What lies ahead for the modern office? According to Raveh, the main trend for smaller business communication systems seems to be in efforts to increase flexibility and reduce costs and time.

TADIRAN, with 1,600 employees in its telecommunications division, of whom 700 are engineers, and with some \$30 million earned in exports last year, is one of the largest in the telecommunications field in Israel. It is equally optimistic about the prospects for Israel's penetration into the international market.

"We sell brainpower," says division manager Haim Rosen. "You don't need oil for that."

Tadiran also produces a line of sophisticated electronic telephone systems, which does practically everything in an office but make the coffee. Its features include such things as conference calls, call-queuing (if the line you are calling is busy, the system will automatically keep calling and let you know when the line is free) and night answering.

Other central office systems the company has developed include a computerized telephone directory system, sold to governments in Turkey, Finland and Greece, to look up numbers automatically, and an interceptor system, which automatically provides the new number for a caller who dials the old number.

Tadiran also markets a complete computerized rural telephone system to provide small, isolated communities with the same service available to big-city residents.

In the transmission field, a great deal of research has been done into savings on the vast quantities of copper wire needed to make the connection between the user and the switching premises.

The result has been the development of a range of multiplexer equipment which can take many voice channels, transform them into data and transmit them through pulses over a single line.

Tadiran has been active in developing voice and data products, both digital and analogue, with military and civilian applications.

One of the most promising fields of the future is fibre optics, and

Tadiran, which entered the field five years ago, is now testing a fibre-optic telecommunication network system in Israel. The system uses light instead of electro-magnetic signals to transmit. Fibre-optic cables are lighter, smaller and cheaper than copper wire.

Looking into the future, a description of some of the products Tadiran is working on sounds like a science fiction vision of a micro-processor-driven world.

As well as office services systems, which can be linked up to such equipment as copiers, word processors and facsimile machines, Tadiran is experimenting with electronic mail transmission and an electronic voice system which stores a voice message and plays it back at a convenient time.

Ahead, too, lies a cashless community in which shopping, banking and other functions can be done through home terminals. Tadiran plans to be there with the right equipment when that happens.

ANOTHER ISRAELI company which is making efforts to maintain a competitive edge in the expanding computerized communications industry is Motorola Israel Ltd.

Motorola Israel has the advantage of having an American parent firm which is the second largest in the world in semi-conductors and micro-electronic technologies, thus giving them access to the latest state-of-the-art techniques. But the local company also as an extensive R&D programme, on which it spends some 7.5 per cent of its revenue.

Exports amounted to \$24 million in 1981, about 40 per cent of the firm's total sales, and major efforts have been made to penetrate the North American market — with some success: about one-third of all exports go to the U.S. and Canada.

The firm's major products include radio communication systems, data communication systems, radio alarms, motitoring and control equipment, as well as a

wide range of military electronics.

Particularly successful has been automatic irrigation-control systems, which, as far as possible, computerize agriculture. Sensors in a field give information on such factors as wind, temperature and water pressure, and this is transmitted to a central computer which adjusts irrigation accordingly. The result, according to Motorola, is a saving in energy, labour and water, as well as better crops.

In the field of communications, the firm produces an Intrac 2000 radio-control system which enables a central station to communicate safely and accurately with a number of remote, unmanned units. It can be used, for example, by the military, for security and control of ammunition and nuclear storage areas, or for smoke and fire detection.

Motorola plans to devote efforts in the future to the development of communications equipment, such as radio-telephones, digital line communication and computerized command and control stations.

THE ELECTRONICS CORPORATION of Israel Ltd. — ECI — has also helped put Israeli telecommunications products on the world map with their unique Telephone Line Doubler system.

This system can increase the capacity of trunk lines by detecting the silent periods which occur in normal conversation and filling them with voice signals with the use of sophisticated micro-processors and control circuitry.

Thus, congested telephone trunk lines can carry more than twice as many telephone conversations as they normally do, saving substantial amounts of both time and money. The system is compact, portable and easy to install.

The Telephone Line Doubler has achieved success overseas and is now in operation in 14 countries with exports expected to reach some \$9 million this year, up from \$3.5 million last year.

*Carol Novis*

NEW IMPROVED PUBLIC TELEPHONES

Maputo NOTICIAS in Portuguese 10 Jul 82 p 2

[Excerpts] New public telephones will soon be installed in Maputo and subsequently in other provinces of the country, Mozambique Telecommunications Company official Avelino Afua announced. Afua added that 704 instruments imported from England are already in Mozambique.

The new telephones are equipped with an electronic mechanism, replacing the mechanical mechanism, enabling users to make lengthier calls and to place inter-city calls.

The instruments, metal-plated (which makes them highly resistant to abuse), consist of a telephone, an unbreakable metal coin box and a microtelephone cord with steel wires encased in plastic.

Another noteworthy feature of the new telephones is the construction of the microtelephone set, which can only be removed with the use of a special key, thus preventing the blatant theft that occurs with the present instruments.

Booth Construction Under Study

According to Afua, the shortage of lumber is temporarily delaying construction of the booths in which the phones will be installed.

A study of their construction concluded that the booths should be built of solid wood and also designed to withstand abuse of this public property.

Training Installers

Meanwhile, instruction in the installation and mechanical adjustment of the phones is being given in an intensive 15-day mini-course, which began on 7 July at the facilities of the Training Center of the Mozambique Postal Service in Maputo.

The course is being taught by Albert Scrafton, a British technician specialized in this field, and is aimed at training Mozambican technicians to install and service the telephones.

6362  
CSO: 5500/5876

## OYO STATE TO HAVE SEVEN TELEVISION STATIONS

Lagos DAILY TIMES in English 2 Aug 82 p 5

[Text]

**T**HE television service of Oyo State will have seven transmitting stations when it goes into operation this month, the state Chairman, directorate of Information, Mr. Yemi Farounbi, has said.

The seven transmitting stations, he said are to enable all parts of the state to tune to the station.

The stations would be sited at Ogbomosho, Ile-Ife, Ibokun, Agunreke, Shaki, Illa and Ibadan.

Conducting journalists round the permanent site of the television at Iwo, Mr. Farounbi said the television service would adopt a multi-production centre approach and that a sum of over ₦1.5 million had already been spent on the purchase of sophisticated machines for this purpose.

He said initially, the television would start transmission at Ile-Akede, Bashorun, Ibadan with the aid of two outside broadcasting vans and recording centre at the FESTAC Building, Mokola.

Mr. Farounbi said that the permanent site which cost the State Government about ₦7.9 million comprises four production studios, a transmission studio, office complex, a canteen and a small hospital for the welfare of the workers.

He said the first chain of transmitters of the television service is being assembled at the Old Ife Road, Ibadan,

while the 25KW channel 28 transmitters would radiate from aerials on a 200 metre tower now under construction.

Answering a question, Mr. Farounbi said both the state Radio and Television services would be under one board of directors and that the State Government had already spent ₦11 million on the purchase of equipment for the take-off of the television.

## NATIONALISTS' USE OF TV TO IMPOSE OWN VIEWS HIT

Johannesburg RAND DAILY MAIL in English 24 Jul 82 p 5

[Editorial]

[Text]

**T**HIS week's reports that the Government might allow an independent television channel are far too good to be true. One does not have to be an astute television critic to realise how the Nationalists are using the existing TV service to impose their views on the public.

SABC-TV's one-sided coverage of the Ingwavuma and KaNgwane land deal once again provided telling evidence of how Auckland Park serves the Nationalists' cause. To believe that the Government will entertain the idea of relinquishing part of this control by allowing the establishment of a totally independent service, is so far-fetched as to be virtually unthinkable.

It is all very sad, of course, as there is no substitute for competition in the pursuit of excellence. Which is a major reason why both the radio and TV services of the SABC — staffed as they are by some very talented people — seldom get beyond mediocrity.

But while it is unfortunately difficult to imagine the Government sanctioning an independent fourth channel, there does appear to be some hope for discerning viewers. Bophuthatswana wants to set up a TV service which will be able to

beam programmes throughout the Witwatersrand. Mr Henry Howell, chairman of the Bophuthatswana Broadcasting Advisory Board, confirmed this week that talks between the South African and Bophuthatswana governments were continuing.

People living in the Johannesburg area will know that Bophuthatswana already has a successful radio station, Channel 702, which is making strides against the SABC's listenership monopoly. While it is difficult to imagine a homeland's TV service enjoying carte blanche to do exactly as it pleases, it is reasonable to believe that even within the restrictions that might apply, such a service can hardly fail to be a worthwhile competitor to the SABC.

Amidst the talk about possible new channels, it is ironic to have SABC-TV screening Westgate's portrayal of Bonnie Thornton as a controversial television interviewer. Here was TV interviewing at its sharpest and inquiring best. It's the way it should be done. Perhaps some hope remains: if the SABC can allow such good investigative journalism in a soap opera, there's at least a chance that the practice will spill over into real life, into TV's everyday news programmes.

SOUTH AFRICA

BRIEFS

JOHANNESBURG TELEVISION TRANSMITTER--A second TV2-TV3 transmitter in Johannesburg will begin operating full time on 16 August. The transmitter will eventually be used to facilitate either TV2 or TV3 once the second channel has been separated. In the meantime it will be used as an additional transmitter for TV2 or TV3 and the first month of operating will be considered a test period. Normal TV2 and TV3 programs will be broadcast but transmissions may be interrupted during this period without prior warning or apology in order that adjustments or repairs may be made. The transmission will be on channel six and horizontally polarized. VHF receiving antennas color coded blue will give best results. [Text] [LD111625 Johannesburg International Service in English 1600 GMT 9 Aug LD]

CSO: 5500/5885

BRIEFS

GEC TELECOMMUNICATIONS TOWER--The GEC telecom tower off the Hatfield Road in Harare has recently been completed with the addition of a dish aerial. The aerial, which is 3.7 metres in diameter, was added to the 85,5 metre tower last week. The tower has been built as part of the communications system for the NRZ electrification scheme in which GEC Zimbabwe is playing a major role. [Text] [Harare THE FINANCIAL GAZETTE in English 30 Jul 82 p 2]

CSO: 5500/5886

INTERNATIONAL AFFAIRS

EEC DELIBERATES FURTHER ON IBM MONOPOLY CHARGE

Paris ZERO UN INFORMATIQUE HEBDO in French 1 Jun 82 p 40

[Article by Rex Malik]

[Text] The European Community vs. IBM: the case has taken a new turn after the hearing last February before the EEC commission responsible for competition policy within the Common Market (DG IV).

IBM's status has been a major element in the company's defense. As a European company, it pointed out that if convicted of the charge, the Japanese would be the only ones who would benefit. And in the second place, as any action taken against IBM would also affect competition in the United States, the only competent authority in this case is the U.S. government itself, according to IBM's defense arguments.

The hearing followed investigations that have been going on since 1974. The week-long hearing set a precedent, since no company before had been given so much time to speak. Then the normal procedure consists of announcing the steps that IBM would have to take, in order to make the market more competitive. At this stage, the company can either accept or reject the commission's decisions. If it rejects the ruling, it can then appeal to the European Court of Justice. That is the final recourse, at the end of which IBM will have to bow to the court's verdict.

The objections of the European Commission are based on four types of arguments. First of all, in the computer market, IBM enjoys a position from which it has improperly benefited. In what way? By not selling principal computer memories separately from the central units, by providing information only to its direct customers, and finally, by establishing a policy that binds inseparably the operating system and the equipment.

Over 2,000 Pages

Aside from its actual defense, a diplomatic memo indicates that the U.S. secretary of commerce sent his general counsel, Sherman Unger, as a simple observer. But other sources reveal that Mr Unger spent a considerable amount of time with the vice chairman of the commission, Frans Andriessen, and with the director, Manfred Gaspari.

He also publicly stated that the commission should not pursue its action.

The written defense is contained in three huge volumes, totalling over 2,000 pages, with a great deal of testimony as well as the results of studies conducted by IBM.

#### Prejudicial Remedy

The defense arguments include several facets. First of all, IBM claims that the DG IV did not follow the normal and customary procedure used in this type of case. IBM claims that, because of its worldwide operation, the remedies proposed by the commission could not be limited just to Europe, but would also have consequences everywhere else, in particular in the United States.

As the outcome of the case against IBM in the United States favored IBM, it seems difficult (claims IBM) for the European Commission to reach different conclusions. In fact, the commission can not dispute the fact that competition plays the same role in the United States as it does in Europe.

Furthermore, IBM clearly drew the attention of the commission to the fact that the action taken against IBM would benefit only the Japanese. On this issue, however, we can comment that this argument does not take into account the moves by some European companies, such as ICL and Siemens, who recently signed agreements with Japanese companies, such as Fujitsu. The European companies felt this was the only way they could possibly compete with IBM.

Another type of argument attempts to show that the computer market is not like what was described by the commission. IBM explained at length that the market is open, and that all companies have access to it, stating that there is no IBM monopoly. Citing examples, IBM claimed that there are a good number of cases in which IBM supplied the first equipment, which was later completed either with other IBM equipment, or in many instances, with equipment made by other companies.

## Memory Losses?

On the problem of memories, IBM won a tactical victory through the technical presentation of its expert, who is also the commission's expert, explaining the difficulty of separating central units. On this point, an attorney for the Memorex firm turned around the argument. He cited examples of central units of the 370/155 and 370/165 models sold without their memory.

A final element, one whose weight can not be underestimated, was cited by Jacques Maisonrouge. IBM in Europe is among the 10 biggest taxpayers of the European Economic Community. Each year it pays about 500 million ECU [European Currency Units].

Since the hearing, the commission has decided to pursue its action, and there are indications that 2 more years of deliberations will be needed before a conclusion is reached.

7679

CSO: 5500/2304

## STRESSED OPTICAL FIBERS, THEIR USE AS POLARIZING COMPONENTS

Milan ALTA FREQUENZA in English May-Jun 82 pp 159-163

[Article by Valerio Annovazzi Lodi, Slivano Donati, Istituto Di Elettronica, Universita Di Pavia: "Stressed Optical Fibers and Their Use as Polarizing Components"]

[Text]

ABSTRACT - After treating the most common cases of fiber stressing, i.e., bend, twist and transversal compression, we show how to make polarizing components (i.e., wave retarders, rotators and, in principle, polarizers) by means of short pieces of monomode fiber to which a controlled stress or bending is applied.

## I Introduction

Recently, some developments in instrumentation based on monomode optical fibers have dealt with the polarization properties of the mode propagation [1, 2]. This topic is also related to the well-known microbending and stress-induced effects in telecommunication applications of monomode fibers, where usually the polarization state is not maintained. Oppositely, if the waveguide modifications are introduced in a controlled way, we can build a number of polarizing components useful in several applications.

Polarizing components made by short pieces of fiber may be used to implement several functions in electrooptic instrumentation, e.g. modulators, wave retarders, polarization rotators, particularly in all-fiber configurations of interferometers and gyros. Generally, those examples reported so far are of the transversal compression type, and a mechanical actuator or a piezo-transducer is used to stress normally the axis of a short section of a straight fiber sample [3]. In this work we present a different type of retarder, based on a small loop of fiber, which can be easily trimmed to quarter and half-wave: such a device is very stable, reproducible and simple to implement.

Also, we analyze in a unified view the main schematic cases of stress induced birefringence, i.e. flexure, compression and twist. In our analysis we assume a small stress approximation, i.e., a linearity regime, and derive simple but accurate expressions for the evaluation and the design of stressed fiber components.

Finally, we present experimental results that fit adequately well the theoretical expressions.

## II Compression and Torsion Birefringence

## IIa Compression Stress

Let us consider a compressive force  $F$  applied normally to the axis of a circular monomode fiber of length  $L$ , as in fig. 1a. To schematize the effects of compression on the index of refraction distribution, we consider the stress components  $T_1$  and  $T_3$  along the  $x_1$  axis which can be expressed in terms of  $F$  by the following equations [4]:

$$(1) \quad T_1 = \frac{F}{2\pi r L} \cos^2 2\vartheta$$

$$(2) \quad T_3 = \frac{F}{2\pi r L} (1 - 4 \cos^4 \vartheta)$$

where  $r$  is the outer fiber radius and the angular coordinate  $\theta$  is shown in fig. 1. Here, it is  $T_1 > 0$ ,  $T_3 < 0$  according to the definition of stress and to the usual sign convention of the theory of elasticity [5]. We use the standard notation  $S_k = s_k T_1$  to express the strain/stress equation and we note that, in an isotropic material like the fiber can be assumed, the elastic matrix  $s_k$  depends only on the two parameters  $\nu$  and  $E$ , i.e., the Poisson and Young moduli.

The stress distribution produces a variation of the refractive index in the fiber, i.e., a linear birefringence whose principal axes are  $x_1$  and

$x_3$ , by symmetry. Now, we can express the variation of the impermeability tensor components as [5]:

$$(3) \begin{aligned} \Delta k_i &= q_{ij} T_j \\ \Delta k_i &= p_{ij} S_j \end{aligned}$$

where  $q_{ij}$  and  $p_{ij}$  are the stress and strain elasto-optic coefficients which, for an isotropic material, are such that  $q_{11} = q_{22} = q_{33}$ ,  $q_{12} = q_{21} = q_{13} = q_{31}$ ,  $q_{44} = q_{55} = q_{66} = (q_{11} - q_{12})/2$ ,  $q_{ij} = 0$  for  $i+j > 5$ ,  $i \neq j$ . Similar relations hold for the  $p_{ij}$ 's.

From eq. (3), using the definition of  $n$ , we get the variation of the refractive index along the axis  $x_i$  [5]:

$$\Delta n_i = -1/2 n^3 q_{ij} T_j$$

$n$  being the refractive index in unperturbed conditions. We have then:

$$(4) \Delta n_3 - \Delta n_1 = 1/2 n^3 (q_{11} - q_{12})(T_1 - T_3)$$

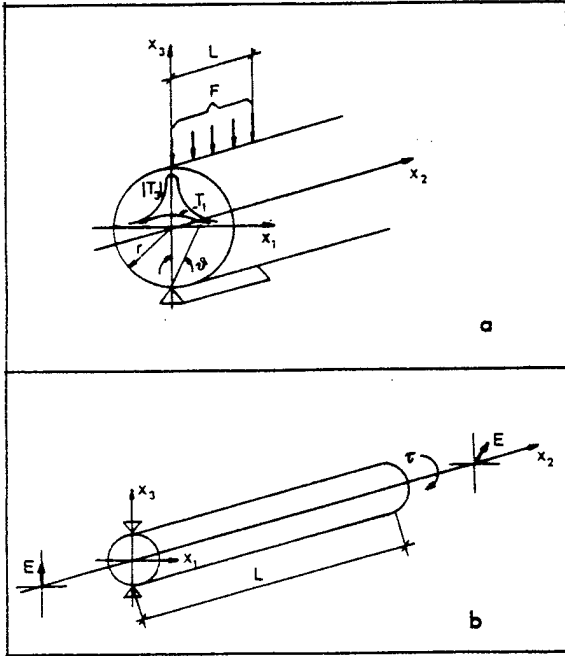

Fig. 1a) - Compression of an optical fibre by a force  $F$ . The strain distribution  $T_3$  and  $T_1$  are also shown.

Fig. 1b) - Twist of an optical fiber by an angle  $\tau$ .

Since both the stress distributions  $T_1$  and  $T_3$  are rather flat around their maxima (located on the  $x_3$ -axis), we may assume a constant birefringence in the core, neglecting mode distortions. Taking the averages of  $T_1$  and  $T_3$  on the core, we get at the first order:

$$(5) \begin{aligned} T_{1C} &= \frac{F}{2\pi r L} \\ T_{3C} &= \frac{-3F}{2\pi r L} \end{aligned}$$

At the fiber output, the relative phase-shift between two modes polarized along the principal axes (i.e., two orthogonally polarized  $LP_{01}$ ) is then:

$$(6) \Delta \Phi_{31} = 2n^3 (q_{11} - q_{12})F / (\lambda r)$$

where  $\lambda$  is the vacuum wavelength. This result can be expressed in terms of  $p$ -coefficients [6] by eqs. (3), obtaining:

$$(7) \Delta \Phi_{31} = 2n^3 \frac{1+\nu}{E} (p_{11} - p_{12}) \frac{F}{r \lambda}$$

From eqs (6), (7), one can see that a linear polarized field fed into the fiber may change into circular or elliptical after propagation, since the fiber acts as a birefringent plate. Since the quantity  $q_{11} - q_{12}$  is negative for silica, the fast and slow axes are that of the applied force and that perpendicular to it, respectively. The differential phase-shift depends on  $F$ , but neither on the length  $L$  nor on the core diameter.

#### IIb. Torsion Stress

Secondly, let us consider the case of a monomode fiber twisted by an angle  $\tau$  around its axis as in fig. 1b: this leads to circular birefringence of the fiber sample.

The only non-zero components of the stress are now, in a first approximation (which disregards the small axial stress  $T_2$ ):

$$(8) T_4 = \frac{\tau}{L} x_1 \frac{E}{2(1+\nu)}$$

$$(9) T_5 = \frac{\tau}{L} x_2 \frac{E}{2(1+\nu)}$$

The  $[\epsilon]$  tensor can be obtained from the  $[k]$  tensor which is directly related to the  $p_{ij}$ 's. We have, at the first order:

$$(10) \begin{aligned} \epsilon_1 &= \epsilon_2 = \epsilon_3 = n^2 \\ \epsilon_3 &= 0 \\ \epsilon_4 &= -\epsilon_5 = -p_{44} \tau r n^4 / L \end{aligned}$$

where the abbreviated notation is used also for the components of  $[\epsilon]$ .

Note that, since the permittivity tensor depends on the coordinates, it is important to consider the fiber as true guiding structure, rather than as an indefinite homogeneous medium; the solution is then found by setting the boundary conditions. By inserting eqs. (8), (9), (10) in Maxwell's equations and carrying on the subsequent modal analysis, one can find [7] for  $\Delta \Psi$ , the circular birefringence phase difference in a monomode fiber:

$$(11) \Delta \Psi = -n^2 p_{44} \tau$$

Therefore, the plane of polarization of a linear-polarized field becomes rotated by an angle:

$$(12) \Delta \Phi = -1/2 n^2 p_{44} \tau$$

Since, for silica,  $p_{44} < 0$ , the optical rotation is in the same sense as the twist angle.

Note that also in this case the total effect does not depend on  $L$ .

From eqs (8) through (12) it appears that all the information needed for expressing the twist birefringence is contained in the matrix  $[p]$  or  $[q]$ . In fact, it is easy verified that the maximum linear birefringence perpendicular to the fiber axis is proportional to the circular birefringence along the fiber axis. Incidentally, we note that the proportionality coefficient is found to be  $2\pi \sin 2\theta$ ,  $\theta$  being the angle that a circular polarized field propagating along the fiber axis makes with the axis itself in its fictitious helicoidal motion.

#### IIc - Experimental Results

Experiments were performed on several pieces of Valtec SMO5 graded index monomode fiber, using a polarized 5 mW He-Ne laser as the source and a photodiode power meter as the detector. Power was fed into the fiber, whose end-faces were prepared by cleavage, through a 10 mm microscope objective. The first 10 cm piece of the fiber served to ensure the propagation of the fundamental mode and to suppress higher-order modes through a tight loop (see next paragraph). The measurements were performed by polarizing plates inserted before the

power meter, as a comparison between unstressed and stressed conditions of the 20 cm piece of fiber following the launch loop. Preliminary evaluation of the fiber showed that its beating length (the length of a  $2\pi$  birefringence phase shift see [1]) was well in excess ( $\gg 1$  m) of the usable pigtail lengths, so that its residual birefringence could be safely neglected.

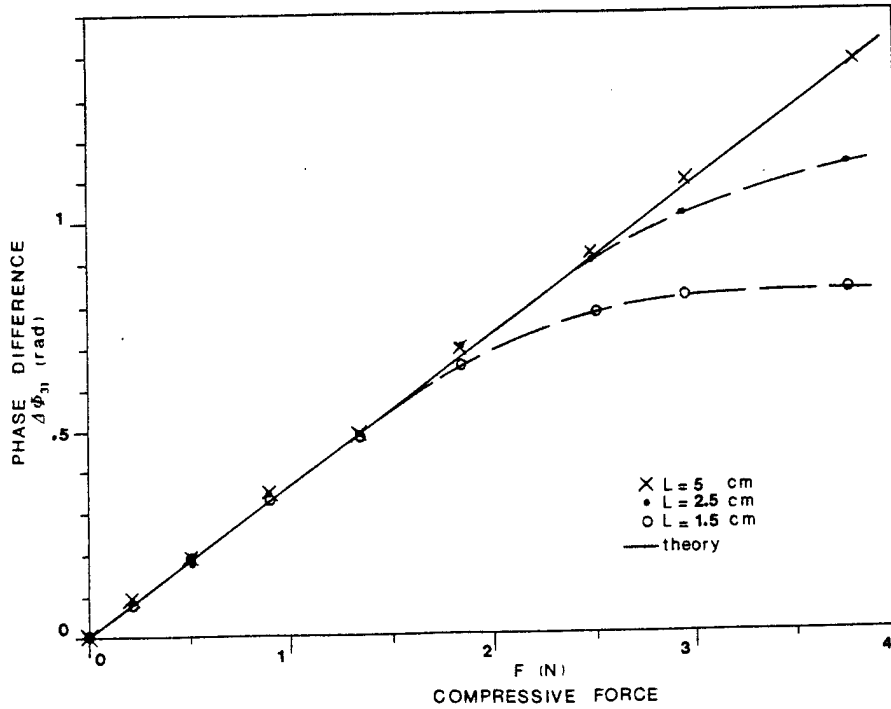

Fig. 2 - Experimental points and theoretical curve for the compression birefringence effect. The range of linearity depends on  $L$ .

In fig. 2 and 3 experimental points and theoretical curves are reported for fiber compression and torsion respectively. The points are the result of a number of measurements performed on several pieces of fiber which showed remarkable reproducibility within the typical error of a few percent; also, no hysteresis was found stressing the fiber up to the points shown in fig 2 and 3. Linearity is well maintained in the former case up to  $F/L = 120$  N/m and in the latter up to the breakage point. For the fiber twist, however, (fig. 3), it was observed a small deviation from the theoretical prediction near the origin; this is difficult to explain since the degree of polarization was not degraded more than a few percent (ruling out residual linear birefringence of the fiber), and the nonlinearity did not depend on the sign of (ruling out circular birefringence).

In our computations we assumed [6]:

$$\begin{aligned} n &= 1.52 \\ r &= 70 \mu\text{m} \\ a &= 8.5 \mu\text{m} \\ \lambda &= 633 \text{ nm} \\ \nu &= 0.17 \\ E &= 7.3 \cdot 10^{10} \text{ m}^2/\text{N} \\ p_{11} &= 0.121 \\ p_{12} &= 0.270 \\ p_{44} &= (p_{11} - p_{12})/2 = 0.15 \end{aligned}$$

Mechanical actuated lateral compression has been used [3] in feedback loops for birefringence compensation; twisting is useful for variable polarization rotators.

While it is not easy to maintain a constant compressive stress for a long time, the birefringent components made by torsion or bending (see next paragraph) are much more stable.

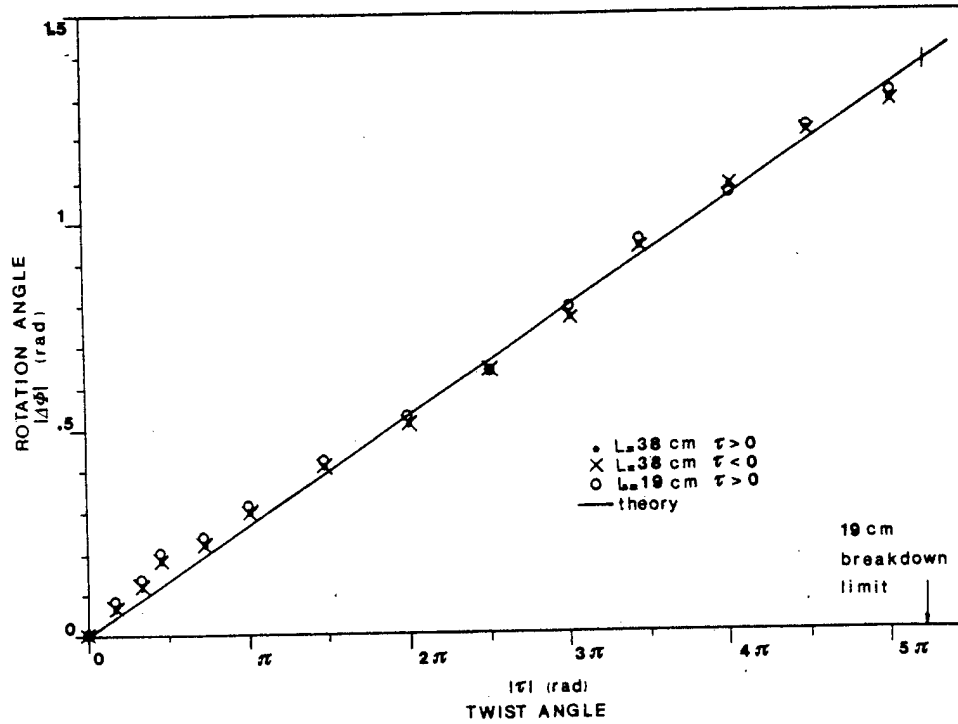

Fig. 3 - Experimental points and theoretical curve for twist birefringence.

$$(13) \quad \Delta\Phi_{31} = \frac{\pi L}{2\lambda} n^3 (\rho_{11} - \rho_{12}) (1 + \nu) r^2 / R^2$$

where  $R$  is the curvature radius.

Eq. (13) was derived by considering the fiber as a homogenous and isotropic bar: the effect of mode distortion was therefore neglected. As a consequence, we found that the predictions of eq. (13) were rather inaccurate when the ratio  $r/R$  was greater than  $10^{-3}$ , resulting, e.g., in an error of about 25% for  $r/R = 8 \cdot 10^{-3}$ .

A more accurate result can be obtained by taking into account the fiber guiding properties. When the fiber is bent, the electric field distribution for both the orthogonal polarized modes is perturbed and its maximum does not lie on the fiber axis but is a little displaced along the bending radius at a point  $M$  whose coordinates have the following dependence [9]:

$$(14) \quad x_{1M} = 0$$

$$(15) \quad x_{3M} = da^2 / R$$

Here,  $a$  is the core radius,  $R$  the radius of curvature and  $d$  is a constant to be determined which depends on the fiber characteristics. The parameter  $d$  can be obtained from the expression of the electric field distribution for the curved fiber [10], [11] along the radius of bending, i.e.:

### III Bending Birefringence

Let us consider a monomode fiber bent along an arc or coiled: we can neglect the torsion component of the strain provided that the radius of curvature is not too small; in other words we assume that the fiber is simply flexed (see fig. 4). Ulrich [8] has evaluated the phase difference due to the stress induced birefringence as:

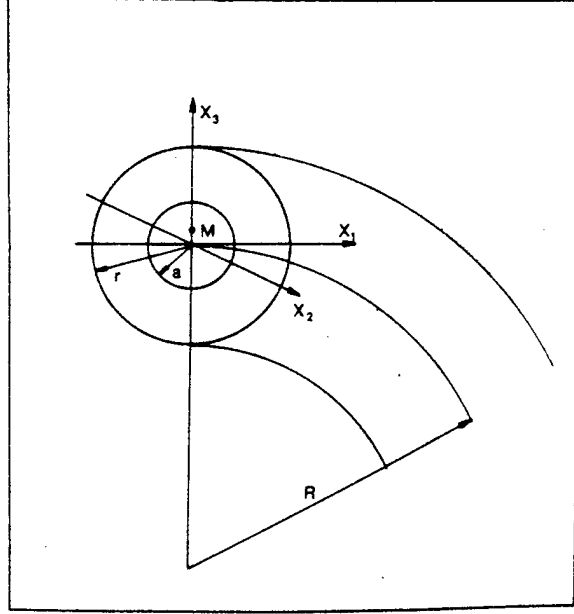

Fig. 4 - Fiber bending schematics; the maximum of the electric field distribution is displaced along the  $x_3$ -axis to point  $M$  (see text).

$$(16) E_{x_i} = J_0(ur/a) - \frac{v^2 u a}{R \delta} \left( \frac{r^2}{4u^2 a^2} + c \right) J_1(ur/a)$$

$$i = 1, 3$$

In this equation,  $\delta$  is the relative refractive index difference of the fiber and parameters  $u, v, c$  can be found in Ref. 11. Since we expect little field distortion to occur under our assumption of small stress, we can use a first order approximation for the derivative of eq. (16) to determine the coordinates of point  $M$ , thus obtaining for the parameter  $d$ :

$$(17) d = \frac{1}{4b\delta}$$

where  $b$  is the normalized propagation constant of the weakly guiding theory [12].

Consider now that the transversal section of the bent fiber cannot be longer considered as circular but becomes distorted [13], thus leading to a variation of the local density or the material as well as of the refractive index. We can easily obtain the refractive index difference for the two distorted  $LP_{01}$  modes corresponding to point  $M$ .

With this aim, we consider the strain distribution along the axis  $x_1$  and  $x_3$  in the fiber section. Making an approximation of the same order of that employed in deriving eq. (13) [8], we can neglect the effect of the strain component  $S_1$ , while  $S_3$  can be expressed as [13]:

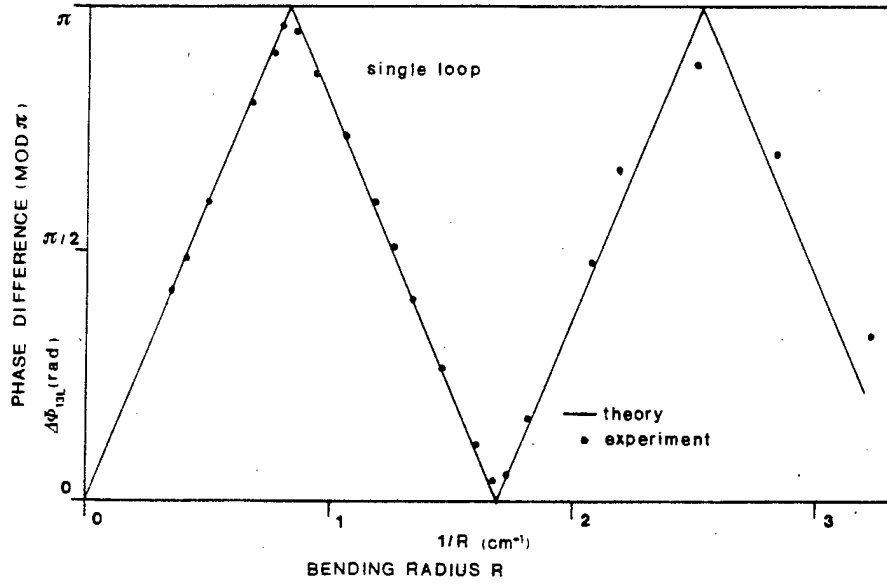

Fig. 5 - Experimental points and theoretical curve for the bending birefringence effect in a single loop of fiber.

$$(18) S_3 = -\alpha x_3/R$$

The refractive index difference in the point  $M$  is then:

$$(19) \Delta n_1 - \Delta n_3 = 1/2 n^3 (p_{12} - p_{11}) \alpha x_{3M}/R \\ = 1/2 n^3 \alpha d (p_{12} - p_{11}) a^2/R$$

Since for silica the quantity  $p_{12} - p_{11}$  is positive, we can conclude that the fast axis coincides with the curvature radius. The relative retardation between the two polarizations is then:

$$(20) \Delta\Phi = \Delta\beta L$$

and since for weakly guiding fibres [12]:

$$\beta = (2\pi/\lambda) n (b\delta + 1)$$

$$\Delta\beta \approx (2\pi/\lambda) (b\delta + 1) \Delta n$$

we have:

$$(21) \Delta\Phi_{13} = (\pi/4\lambda) (b\delta + 1) (b\delta)^{-1} L n^3 (p_{11} - p_{12}) \alpha a^2/R^2$$

This expression is similar to eq. (13) but it shows a dependence on the guide parameters. Moreover, the total effect is found to be proportional to the core (not the clad) radius. Eq. (21) holds under the assumption of linear elastic behaviour, but does not require a negligible field perturbation assumption.

In practice, it is useful to implement birefringent components by making small *loops* or *coils* of optical fiber and then trimming their bending radius; the greater the number of loops, the greater the accuracy, but also the bending attenuation increases. For a single loop eq. (21) gives:

$$(22) \Delta\Phi_{13L} = (\pi^2/2\lambda) (b\delta + 1) (b\delta)^{-1} n^3 (p_{11} - p_{12}) \alpha a^2/R$$

showing a dependence on  $1/R$ .

We have fabricated several samples of  $\lambda/2$  and  $\lambda/4$  retarders by this loop techniques and found that their reproducibility and stability in time were very satisfactory without special requirements of mechanical assembly. In particular we report in fig. 5 theoretical and experimental results pertinent to eq. (22). The agreement is good except for very small values of the bending radius where nonlinear effects are probably present and the strain cannot be longer considered as due to a simple flexion. Computations were made using the parameter values reported in Sec. 2 and furtherly assuming  $b = 0.6$  and  $\delta = 2.2 \times 10^{-3}$  [12].

When a fiber is bent, an attenuation is introduced due to the excitation of radiative modes, the attenuation constant being proportional to  $\exp(-R)$  [14]. For most applications, the radius  $R$  of the birefringent component must be chosen for a minimum attenuation, but in some cases one may exploit this effect for mode filtering, since the attenuation depends on the order of the mode.

We have tested these considerations on a sample of Valtec SMO5 which is two-mode at 630 nm. With radius of the loop around 1 cm. or less, we got a good attenuation of the higher mode. In the range  $5.8 \text{ mm} > R > 12 \text{ mm}$  we have the possibility of obtaining any differential retardation in addition to an efficient mode filtering and a small attenuation of the fundamental mode; a good reproducibility was found for these components.

In fig. 6 we report the measured attenuation for both polarizations of the  $LP_{01}$  mode along with the theoretical attenuation curve for the higher mode  $LP_{11}$  [14].

The attenuation difference between the two orthogonal polarizations of the fundamental mode suggests the possibility of making polarizers and this will be the object of further investigations. Note also that this effect may be partially responsible for the nonlinearity shown in fig. 5 for  $1/R > 2$ .

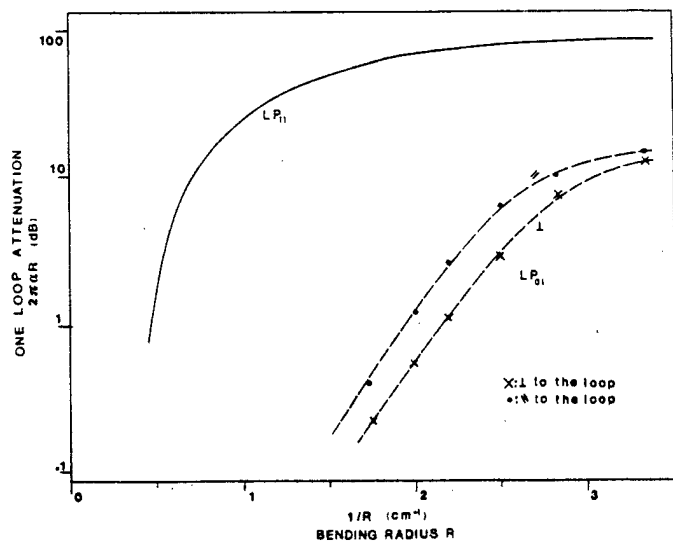

Fig. 6 - Single loop attenuation for the  $LP_{01}$  mode: differential attenuation between the two polarizations has been found. The theoretical curve for the mode  $LP_{01}$  [14] is also reported showing a conspicuous attenuation difference respect to the fundamental mode.

ACKNOWLEDGMENTS. One of us (VAL) performed this work under a fellowship awarded by Selenia Industrie Elettroniche Riunite. The work was also supported by the CNR contract CT 80.02036.07

Manuscript received on 8/1/1982

#### REFERENCES

- [ 1 ] I.P. Kaminov: "Polarization in Optical Fibers" *JQE* 17-1 (1981), 15.
- [ 2 ] R. Ulrich, M. Johnson: "Fiber - ring interferometer: polarization analysis" *Opt. Lett.* 4-5 (1979), 152.
- [ 3 ] R. Ulrich: "Polarization stabilization on single mode fiber" *Appl. Phys. Lett.* 35-11 (1979), 840.
- [ 4 ] O. Belluzzi: "Scienza delle Costruzioni" Vol III, Zanichelli, Bologna (1969).
- [ 5 ] J.F. Nye: *Physical Properties of Crystals*, Clarendon Press, Oxford (1960).
- [ 6 ] D. Gray, ed.: "American Institute of Physics Handbook", Mc Graw Hill, New York (1976).
- [ 7 ] R. Ulrich, A. Simon: "Polarization optics of twisted single mode fibers" *Appl. Opt.* 18-3 (1979), 2241.
- [ 8 ] R. Ulrich, S.C. Rashleigh, W. Eichoff: "Bending induced birefringence in single mode fibers" *Opt. Lett.* 5-6 (1980), 273.
- [ 9 ] D. Marcuse: "Field deformation and loss caused by curvature of optical fibers" *JOSA* 66-4 (1976), 311.
- [10] J. Sakai: "Microbending Loss Evaluation in Arbitrary - Index Single Mode Optical Fibers" *JQE* 16-1 (1980), 36.
- [11] J. Sakai, T. Kimura: "Fields in a curved optical Fiber" *JQE* 17-1 (1981), 29.
- [12] D. Gloge: "Weakly Guiding Fibers" *Appl. Opt.* 10-10 (1971), 2252.
- [13] L. Landau, E. Lifchitz: "Théorie de l'Elasticité", MIR, Moscow (1967).
- [14] H.G. Unger: "Planar Optical Waveguides and Fibres", Clarendon Press, Oxford (1977).