

350107

JPRS 82005

18 October 1982

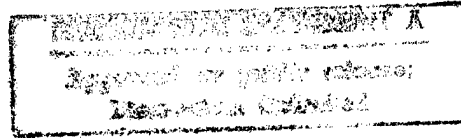

East Europe Report

SCIENTIFIC AFFAIRS

No. 757

19980910 018

FBIS

FOREIGN BROADCAST INFORMATION SERVICE

8
66
A04

NOTE

JPRS publications contain information primarily from foreign newspapers, periodicals and books, but also from news agency transmissions and broadcasts. Materials from foreign-language sources are translated; those from English-language sources are transcribed or reprinted, with the original phrasing and other characteristics retained.

Headlines, editorial reports, and material enclosed in brackets [] are supplied by JPRS. Processing indicators such as [Text] or [Excerpt] in the first line of each item, or following the last line of a brief, indicate how the original information was processed. Where no processing indicator is given, the information was summarized or extracted.

Unfamiliar names rendered phonetically or transliterated are enclosed in parentheses. Words or names preceded by a question mark and enclosed in parentheses were not clear in the original but have been supplied as appropriate in context. Other unattributed parenthetical notes within the body of an item originate with the source. Times within items are as given by source.

The contents of this publication in no way represent the policies, views or attitudes of the U.S. Government.

PROCUREMENT OF PUBLICATIONS

JPRS publications may be ordered from the National Technical Information Service, Springfield, Virginia 22161. In ordering, it is recommended that the JPRS number, title, date and author, if applicable, of publication be cited.

Current JPRS publications are announced in Government Reports Announcements issued semi-monthly by the National Technical Information Service, and are listed in the Monthly Catalog of U.S. Government Publications issued by the Superintendent of Documents, U.S. Government Printing Office, Washington, D.C. 20402.

Correspondence pertaining to matters other than procurement may be addressed to Joint Publications Research Service, 1000 North Glebe Road, Arlington, Virginia 22201.

JPRS 82005

18 October 1982

East Europe Report

SCIENTIFIC AFFAIRS

No. 757

FBIS FOREIGN BROADCAST INFORMATION SERVICE

18 October 1982

EAST EUROPE REPORT SCIENTIFIC AFFAIRS

No. 757

CONTENTS

CZECHOSLOVAKIA

Briefs

Radars Produced for USSR 1

GERMAN DEMOCRATIC REPUBLIC

Data on Industrial Robot Development Presented
(TECHNISCHE GEMEINSCHAFT, various dates) 2

Loading Robots, Manipulators, by E. Paessler
Welding Robots, by Gerhard Schermer, Siegfried Kiese
Welding Robot Component System, by G. Hesse
IR 3-P Loading Robot, by B. Greger

Control Systems for Industrial Robots Described
(H.-J. Bartsch; TECHNISCHE GEMEINSCHAFT, Dec 81) 27

Articulated Robots for Technological Processes Described
(TECHNISCHE GEMEINSCHAFT, Dec 81) 32

Series Production for 1983, by J. Schniese
Electrically Driven Articulated Robots, by M. Schwandtke

Paint-Spraying Robot for Automobile Factory Described
(L. Spreer; TECHNISCHE GEMEINSCHAFT, Dec 81) 41

Industrial Robot IRS 3000 for Drop-Forging Processes
(F. Lange; TECHNISCHE GEMEINSCHAFT, Dec 81) 43

Industrial Robots for Forming Machinery Described
(L. Morgenstern, TECHNISCHE GEMEINSCHAFT, Dec 81) 47

ROMANIA

New Technology Used in Oil, Gas Extraction (STIINTA SI TEHNICA, Jun 82)	51
Increasing Recovery Factor, by I. Sadeanu Well Drilling, by Ion Dobre Automation Program, by Valeriu Patrascu	

CZECHOSLOVAKIA

BRIEFS

RADARS PRODUCED FOR USSR--Tesla enterprise in Pardubice has already delivered over 300 RP-36 radars to the USSR. [Prague LIDOVA DEMOKRACIE in Czech 29 Sep 82 p 4]

CSO: 2402/1

GERMAN DEMOCRATIC REPUBLIC

DATA ON INDUSTRIAL ROBOT DEVELOPMENT PRESENTED

Loading Robots, Manipulators

East Berlin TECHNISCHE GEMEINSCHAFT in German Vol 28 No 2, Feb 80
(signed to press 3 Jan 80) pp 28-32

[Article by Dr. E. Paessler, engineer, first deputy director, research center, Karl-Marx-Stadt Machine Tool Construction Combine and chairman, Machinebuilding Trade Association, Chamber of Technology: "Data on Industrial Robots"]

[Text] To facilitate exchange of experience and to help avoid duplications in development, we have striven for an assemblage of industrial robots from the GDR. The selection was made by professionals from the Research Center of Tool Machine Construction Karl-Marx-Stadt.

Program-controlled manipulators for industrial robots are working machines which are used for the independent handling of work pieces and tools and which can be programmed along several axes of motion as regards their positioning and their working sequence.

Effective use of this technology requires a high degree of planning, organization, and technical-organizational preparation. The following problems generally occur here:

The production means that is to be serviced has too low a level of automation;

the machine which is being loaded is not ready for robot deployment, e.g. control functions which the operator otherwise performs "on the side" must also be automated when industrial robots are used or must be displaced to another work station;

the discharge of chips and auxiliary materials must also be automated.

With first-generation robots, work pieces, which generally are delivered in a disordered state, must be brought into a definite position. Only in the fewest cases do the presuppositions exist in advance for the deployment of industrial robots. In most cases they must first be created. Peripheral equipment is necessary, whose cost can reach 60 to 150 percent of the price of the robot.

As regards the application itself, the most suitable industrial robots must be chosen from a large assortment, which differ, for example, by their mode of construction, their kinematics, their control, handling dimensions, and drive systems, and the most economical solution must be found.

The user must investigate and answer the following questions:

What type of handling technology is suitable for which work stations?

At which work stations can which industrial robots be used?

What additional measures must be initiated and fulfilled to automate the relevant work stations, and especially as concerns the level of automation of the machines that are being loaded and their peripheral equipment?

At the present time, systematic information of this type is often lacking. Such information is obtained from broad user experience.

In the research center for tool machine construction, an appropriate methodology is available for the uniform characterization of industrial robots, for the systematic analysis of work stations that are selected for the deployment of industrial robots, and for working out a project to design technological groups taking into account the necessary peripheral equipment.

We must start from the idea that industrial robot technology, together with other advanced technologies, will span many areas of engineering. This also entails new tasks for our engineering organization. Almost no scientific section and no technical committee remains unaffected thereby. There are many new possibilities for relieving the human person by machines, for the further automation of technological processes. For example, production methods for robot deployment must be modified and/or further developed, new machine elements must be developed, standardization tasks must be solved. Finally, we must note that all this does not happen by itself, and that on a world scale a hard battle is taking place concerning the development and utilization of the most modern technologies and techniques. For us this is a decisive field of class struggle which requires our full engagement. The action of the "scientific-production community of industrial robots" in the region of Karl-Marx-Stadt, which was formed upon the decision of the conference of delegates of the Regional Organization of the SED, should make a contribution towards fully exhausting the advantages for our society for the close connection of science and production.

In this sense, too, the following data concerning industrial robots will surely stimulate many developers and engineers to seek contact with colleagues in other enterprises and institutions, in the interests of their own development, to accept proven solutions, and also to assert their own experiences.

Data on Industrial Robots

Industrial Robot IR 2

Development:

Research Center of Tool Construction in the VEB (state enterprise) tool machine combine "Fritz Heckert" Karl-Marx Stadt. The industrial robot IR 2 is a loading robot in stand-up construction. The standard gripper module is equipped with two gripper tongs. It is used for the in-feed, discharge, and retransmission of work pieces of various outside and inside forms in small and medium-series production. It is possible to load several machines from one or two work-piece storages. The industrial robot has three directions of motion on the basic module and two directions at the gripper module. It works in a maximum action space of 3.3 m diameter and 2.5 m height and moves a maximum useful mass of 20 kg per gripper tong.

Industrial Robot IR 3 P

Development:

Engineering College of Zwickau, Engineering Section of the mvl (expansion unknown), with VEB Sachsenring, Zwickau Automobile works.

The industrial robot IR 3 P is a loading robot in stand-up construction. The standard gripper module is equipped with one gripper tong. It is used to handle different work pieces in the loading of tool machines. It is possible to load two machines from one storage unit. The basic module of the industrial robot has three directions of motion. It works in a maximum action space of 1.7 m diameter and 1.3 m height and moves a maximum useful weight of 3 kg.

Sensor-Controlled Industrial Robot for Assembly

Development:

TH (Technical College) Karl-Marx-Stadt, section of machine components, cooperating partner: Research Center of Tool Machine Construction

The assembly robot consists of a gripper-guidance drive and a sensor-controlled assembly gripper. The gripper-guidance drive moves the gripper to fixed points of the space. Two translational motions and one rotational motion can be executed here. The drive is effected hydraulically through working cylinders and an armature motor. The motions are controlled by servo-valves. The experimental work station for this industrial robot was equipped for inserting a bolt (diameter 60 mm, length 50 mm) into a boring (free play 20 μ m).

The industrial robot was built as a laboratory model to investigate mechanical and information problems with sensor-controlled assembly operations of work pieces that are typical in machine construction.

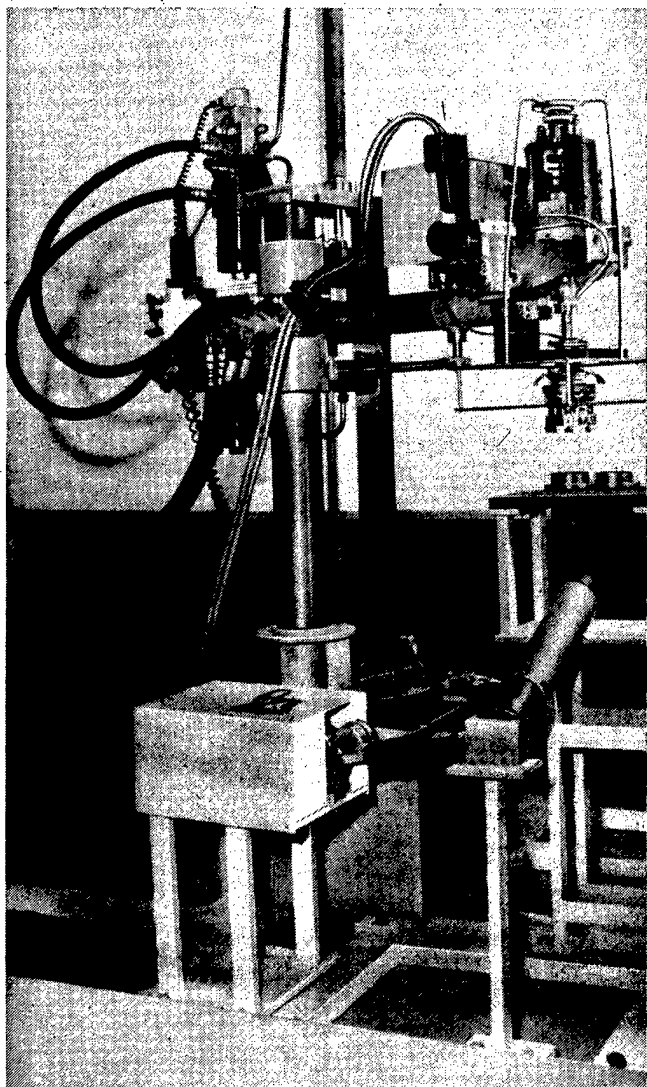
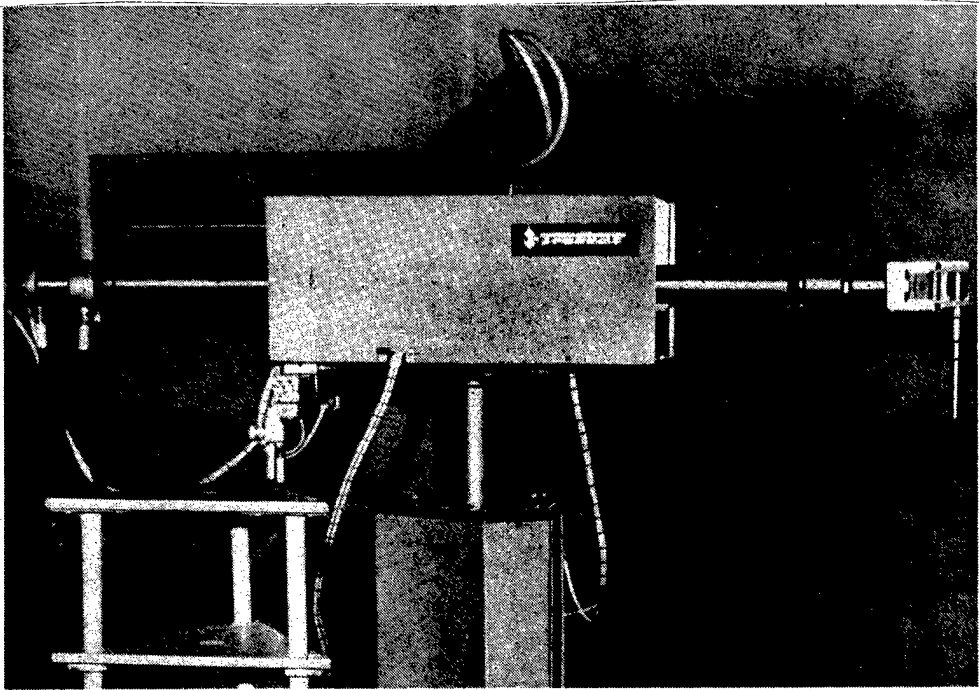

Loading robot IR 3 p (top). Left laboratory model of the sensor-controlled assembly robot.

Freely Programmable Industrial Robot PHM 4

Development:

Trans-enterprise Youth Object of the VEB Combine Robotron Dresden and the TH Ilmenau.

The multi-axis industrial robot is coupled with an optical detection unit. Flat parts that are presented in a disordered state are ordered through the stations "adjust - recognize - grip", and are stored in a magazine. By rapid reprogramming, a large number of different individual parts can be magazined. The PHM 4 is used as an efficiency means in the enterprises of the VEB Combine Robotron. Work is being done on testing further individual cases, e.g. assembly of a "guide arm".

Follow-up use:

Requests are to be directed to the VEB Combine Robotron, Efficiency Section, Weimar, 53 Weimar, Hegelstr. 2 a.

Industrial Robot MIR-1 p

Development:

VEB Mansfeld Combine "Wilhelm Pieck",

The industrial robot is used to load presses and it reduces monotonous manual work. In the particular application, 5760 working hours have been saved.

Site of deployment and follow-up use:

VEB Berlin Foundry Works and Semifinished Goods Works, 119 Berlin, Schnellestr. 131.

Transport Manipulator

Development:

Youth Collective in the VEB Combine on Progress in Agricultural Machines, Neustadt/Sa.

The transport manipulator which has been developed as a prototype is the preliminary state of an industrial robot. Its use leads to greater efficiency in the transport of plow blades which are to be processed in the plow roller lanes. When used in the VEB soil processing devices, Leipzig, a saving of 1800 hours working time as well as quality improvements were gained.

Object Recognition System for Industrial Robots

Development:

TH Ilmenau

The object recognition system and the microcomputer-controlled multicoordinate positioning system are especially suitable to control industrial robots. Furthermore, many processes can be automated, optimized, and monitored thereby. The components of the overall complex consist of a coordinate table, a microcomputer, and a camera.

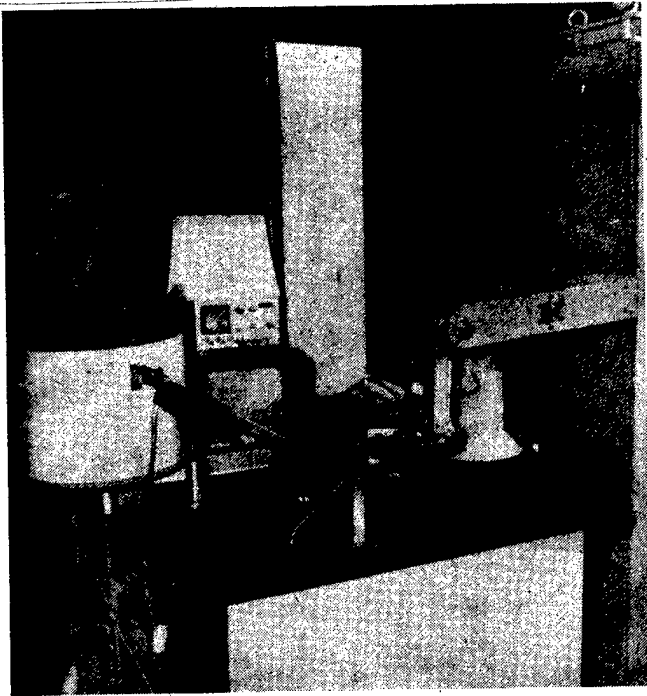

Freely programmable robot PHM 4

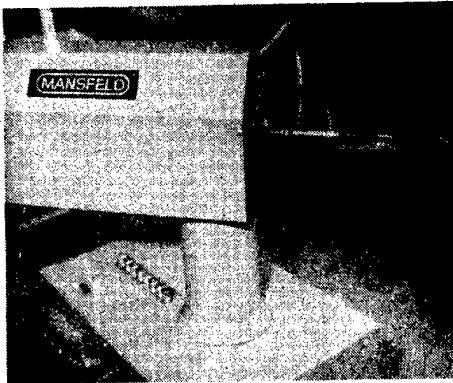

Freiprogrammierbarer Roboter PHM 4

Industrieroboter MIR-1 p

Industrial robot MIR-1 p

Transportmanipulator

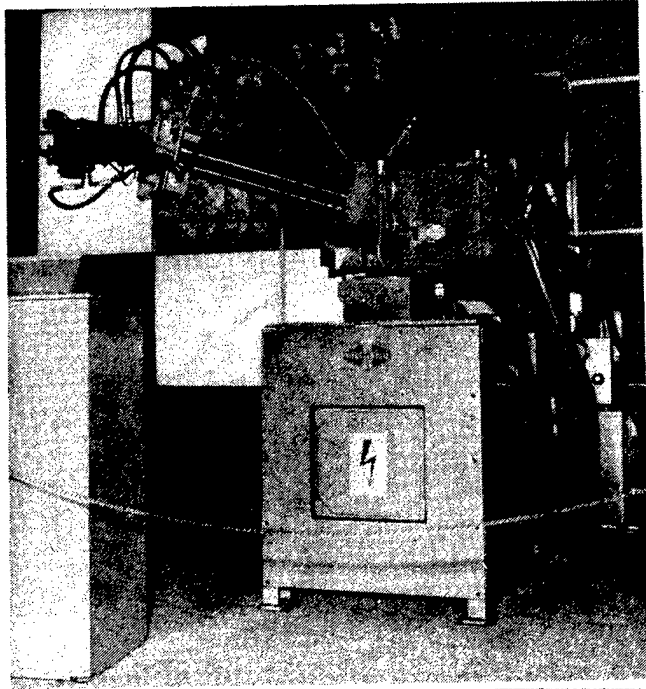

Transport manipulator

The coordinate measuring table is used "digitally" as a positioning system for the x-, y-, ϕ -motion, for the measurement projector MP 320 of the VEB Carl Zeiss Jena. A computer unit with a processing width of eight bits and a cycle of 480 ns is used as a microcomputer. Any software-compatible type can also be used, for example K 1520 of Robotron.

The object recognition system is used industrially, among other places, in the VEB tube factory Neuhaus, in the automated connection of wires on chips (automated transistor production). The VEB Elektromat Dresden is responsible for the preparation of further applications.

Magnetic Pivoting Arm

Development:

VEB Sachsenring, Zwickau Automobile Works

The magnetic pivoting arm functions as an automatic feed-in device for work pieces (rounds) from the transport container to the machine table. The unit works with a pneumatic drive. The grippers are designed as electromagnets (three units in a row). The working program is adjusted individually through limit switches. Follow-up uses in enterprises of the metal-processing industry are possible.

Extraction Device

Development:

Youth Brigade in the VEB Universally Jointed Shaft Works, Stadtilm.

The manipulator works with an hydraulic drive. It is controlled electrohydraulically and, in the particular application, is coupled automatically to the working cycle of a friction-welding machine. The weight of the work pieces being manipulated is maximum 25 kg. In the particular application, the working productivity was increased to 160 percent. The extraction device can be used especially by machine construction systems.

Manually Guided Manipulator

Development:

Engineering School for Machine Construction and Electrical Engineering, Berlin-Lichtenber, jointly with the VEB Elektrodyne and VEB Elektroprojekt and System Construction in Berlin.

The manually guided manipulator is a stationary handling device, preferably for feeding in sheet metal boards with a weight up to 50 kg at guillotine shears. By modifying the gripper mechanism, it can generally be used for the manually guided motion of loads.

It is controlled numerically through DRE-LOBA elements. The gripper is designed as a vacuum load lifting unit for the feeding in of unperforated sheet metal plates. The kinematics of the manipulator correspond to the pantograph principle.

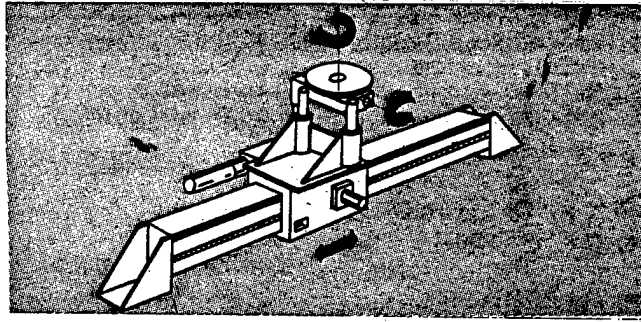

This receiving unit for a welded part is also assembled from modules of the ZIS 995. In this way, the welding robot can be supplemented by three additional motions.

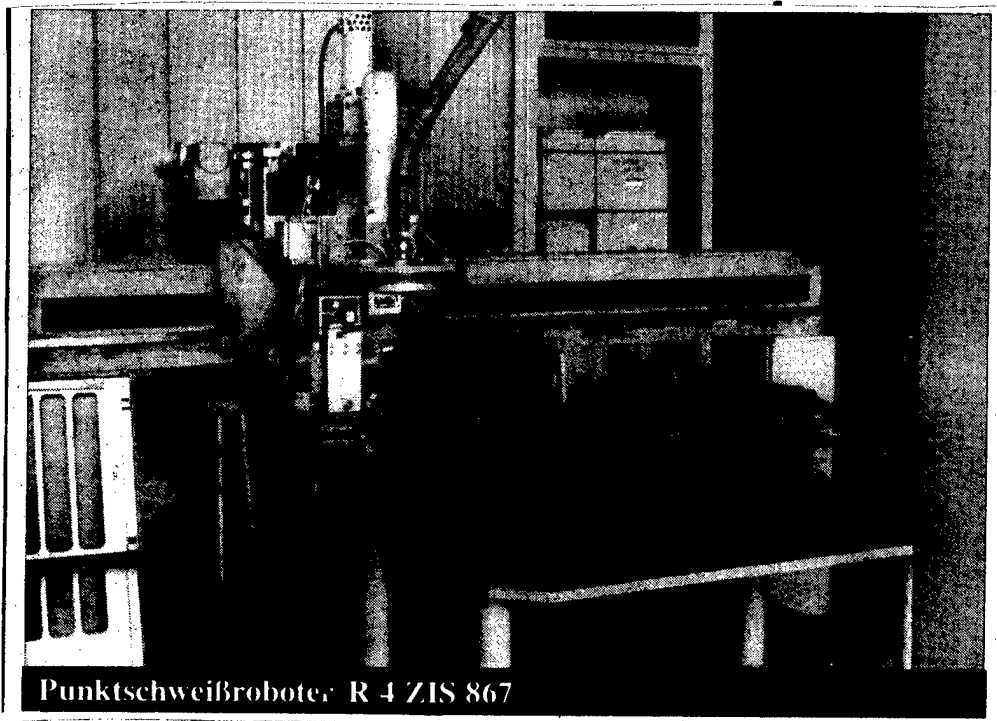

Spot welding robot R 4 ZIS 867

Arc Welding Robot R 5 ZIS 10-41

Development:

ZIS Halle and VEB Soil Processing Devices, Leipzig

Application:

By means of this robot, frame parts for agricultural machines are welded. It is equipped with programs for nine different components. The various receiving units for welded parts are mounted on two indexing tables, which operate in oscillating cycles. They are mutually interchangeable.

The components ZIS 995 are used for the moving apparatus.

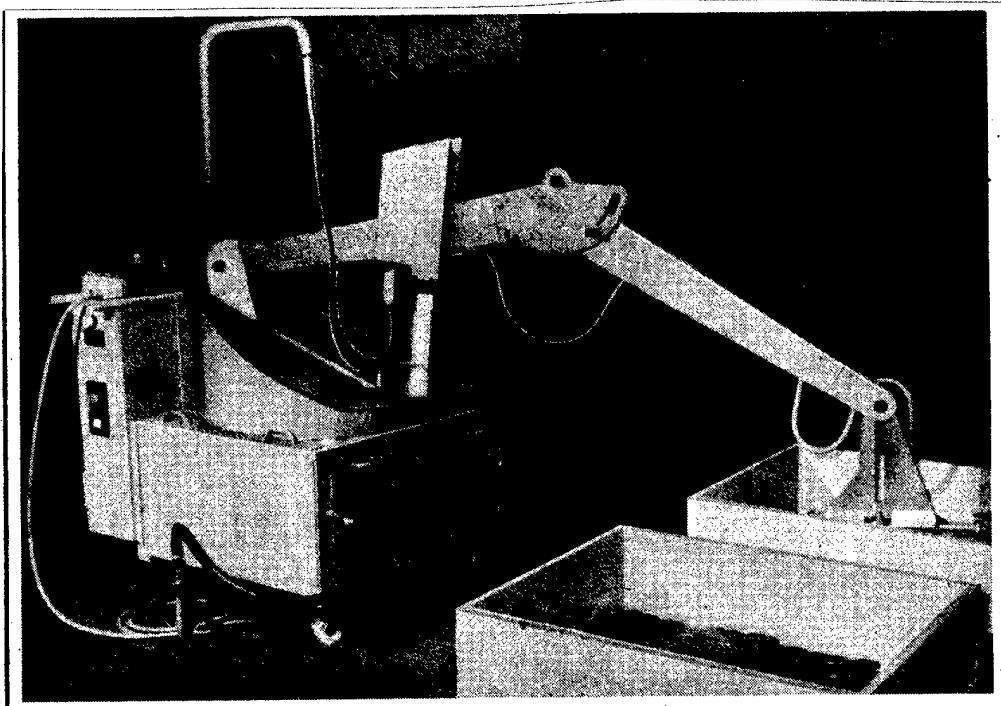

Magnetic pivoting arm

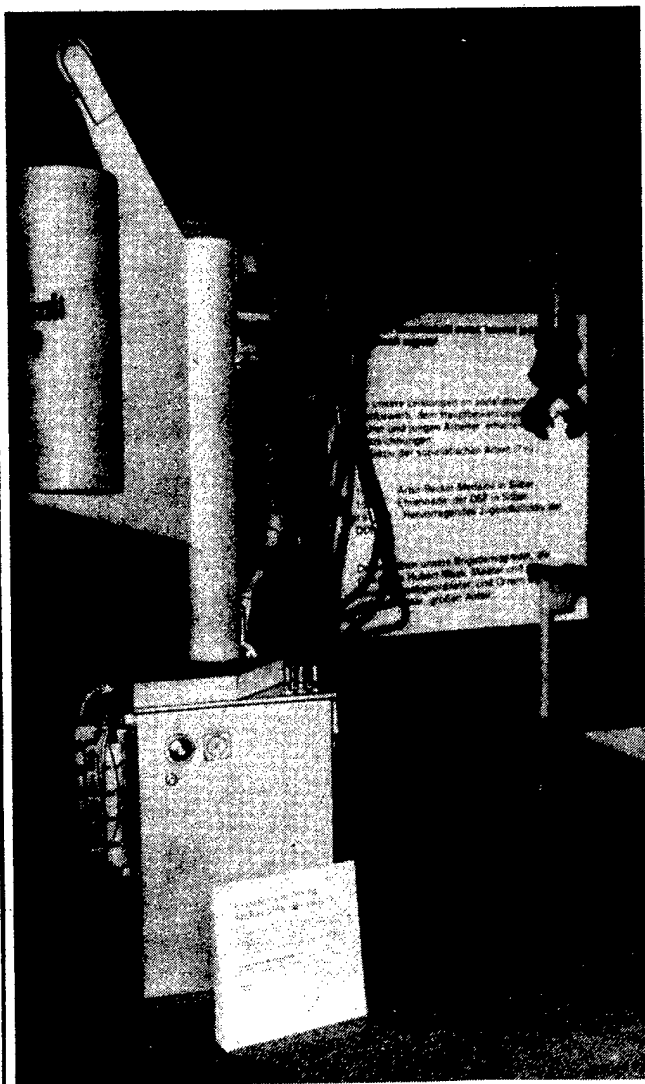

Extraction device

Design radius: max 3000 mm; min 1500 mm; elevation 500 mm; pivoting angle: 180°.

Compensation Lifter:

Development:

Engineering School for Heavy Machine Construction "Walter Ulbricht" Rosswein, together with VEB Heavy Machine Combine TAKREF, VEB Combine ORSTRA Hydraulics, Leipzig, PGH Mechanics Taucha.

The compensation lifter is designed for general handling tasks on tool machines and in assembly, in foundries and in machine construction. It works especially economically with large numbers of units of the same load. The compensation lifter works by the principle of a pneumatic scale. Through its automatic load compensation, it is possible to move objects of different weights without physical effort. The manipulable weight is max 125 kg. The pivoting angle extends up to 360°. Compressed air connection 0.6 MPa. Industrial tests were made in the VEB Mine Lamps of Zwickau (battery shipping). Series production of the device will take place beginning in January 1980 in the PGH Mechanics, Taucha.

Welding Systems with Sensor Control

Development:

TU (Technical University) Dresden, Section on Production Engineering and Tool Machines and ZIS (Central Institute for Welding Technology) Halle.

The welding system is equipped with an inductive sensor system for the noncontacting weld control during automatic welding of fillet welds.

The main components of the welding system are the following: inductive sensor with expander unit, control unit for the welding sequence, active and passive components of the system ZIS 650 and ZIS 995, electromagnetic work piece clamping.

Technical characteristics: A low requirement for positioning accuracy of the welded parts, tolerances with respect to positioning and prefabrication of the parts are compensated fully automatically, the welding of seam contours with limited curvature with the use of two sensor systems and two controllable axes, welding of closed seam patterns with deviations from the circular form.

The industrial follow-up use is agreed upon through the TU Dresden, Area of Production Process Design/Assembly, Prof. Dr. Eng. Blume.

Sensor controlled welding system for fillet seams)
Compensation lifter) Figure captions

Remark of the Editors

Since the beginning of this year, all reproducible solutions of industrial robots, together with further detailed specifications, have been published in the current editions of the WMW (Tool Machines and Tools) catalog for more effective solutions. In the first quarter of 1980, a first special edition with about 20 more widely useable solutions will appear. Likewise in this quarter will begin the training program of "scientific-production association of industrial robots" (WPG) in the Karl-Marx-Stadt region, to prepare for the use of industrial robots. This will be run jointly with the technical association on machine construction of the KDT (Chamber of Technology).

The WPG (expansion unknown), under the management of the General Director of the VEB Tool Machine Combine "Fritz Heckert", coordinates the development, production, the use preparation, and production-effective popularization of modern handling technology.

Requests for FZW (Research Center of Tool Machine Construction) information and training offers as well as for IR (International Counsel) special editions should be directed to the Research Center of Tool Machine Construction, Publicity Department, 9010 Karl-Marx-Stadt, PSF 1061.

Welding Robots

East Berlin TECHNISCHE GEMEINSCHAFT in German Vol 28 No 7, Jul 80
(signed to press 29 May 80) pp 18-21

[Article by Gerhard Schermer and Siegfried Kiese, engineers: "Data on Industrial Robots (Part 2)"]

[Text] The following survey comprises welding robots from the Central Institute for Welding Technology (ZIS), Halle. This continues the publication begun in TG (Technical Association) 2/80, by means of which we promote an exchange of experience in this area and also wish to facilitate in-house construction of these efficiency-increasing means by means of already proven developments.

TG will continue this documentation when the editors receive further information concerning industrial robots capable of wider use.

Since 1975, the ZIS Halle has been developing welding robots. A modular system was generated with the designation ZIS 995. The user can assemble welding robots from the modules, and these robots are optimally adapted to the particular welding task.

The task of the welder to recognize and take into account the component and positioning tolerances must be replaced by corresponding equipment on the welding tools. That is, the welding robot should traverse not only a preprogrammed path but must be capable of recognizing deviations in the pattern of the welded seam and of controlling the welding process so that, despite these deviations, a seam of the appropriate quality is achieved.

Welding robots have high flexibility, so as to facilitate changes on the welded part or in the working sequence with only minimal conversion times and costs. The linkage with production lanes or other technological equipment (e.g. a rotary indexing table) creates the presupposition for the economic use of welding robots.

A welding robot does not consist only of the kinematic chain with the associated path control. To be able to weld, it must be completed with additional technological components, and ZIS is working on their development.

The receiving unit for welded parts and the machine frame are modules which must be tailored to the prevailing geometrical form of the welded part. Consequently, these are designed and built by the user and have a major influence on the

effectiveness of the welding robot. The receiving unit for the welded part must fulfill two essential tasks. It must position the welded part exactly and must supplement the moving apparatus by additional degrees of freedom, so that the welded part can be placed into a position that is favorable for the technological process. For welded parts up to 50 kg weight, such a receiving unit for welded parts can be assembled from the modules of the ZIS 995.

This equipment is also programmed and controlled through the modular robot control ZIS 10-36. The receiving units for welded parts, in conjunction with technological linkage devices such as conveyor lines, oscillating cycle devices, and indexing tables, determine the technical production flow. They are to be disposed so that the welding times and auxiliary times run in parallel.

The moving apparatus of the welding robots is constructed from the assortment of the ZIS 995 modules. By means of the associated modular numerical positioning control ZIS 10-36, axis-parallel and circular seams can be welded. The control can additionally be equipped with positioning sensors. These sensors compensate tolerances at the welded part and conduct the welding work piece with sufficient precision along the welded joint. By means of the control ZIS 10-36, about 80 percent of the automation tasks in welding production can be accomplished.

Welding tools for the robots are the MIG/MAG welding torch and spot-welding tongs. As regards the MIG/MAG torch, at this time one falls back on commercial devices. Development work, especially by the use of sensors, is still required here, so that this torch can be adapted to the needs of robot technology. Machine spot tongs are currently being developed by the ZIS. The planned characteristic values of these lifting and shearing tongs should permit the user a selection of a suitable tong for each welding task. As for the entire moving apparatus and control, the documentation for the spot tongs will also be prepared in such a way that their construction in the business departments for improved efficiency will be possible. The modules of the welding apparatus, both for resistance welding and for arc welding, are available to complete the welding robots.

Data on Industrial Robots (II)

Spot Welding Robot R 4 ZIS 867





Development:

ZIS Halle and Automobile Works Ludwigsfelde

Application:

Body parts for trucks are welded. Two plate-shaped components are rigidly clamped in stationary receiving units for welded parts. A total of 96 points are distributed along their circumference and these are welded in one revolution of the robot. The spot welding system, which must be pivoted by 360°, was specially developed for this application. The modules ZIS 995 are used for the moving apparatus.

Baukastensystem ZIS 995 für Schweißroboter

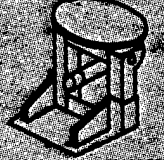
Baueinheit 1		Stellweg 2 (mm, °)	Einbaulage 3	Stellgeschwindigkeit 4 (m/min, °/s)	Belastung (N) 5	
Translation 6		T 100	100	beliebig 10	max. 0,67	100
		T 250	250	beliebig	max. 0,67	100
		T 400	400	beliebig	0,2—7,0	320
		T 1000	1000	beliebig		400
		T 2800	2800	horizontal 11		2500
		T 6300	6300			
Rotation 7		R 360	360	beliebig 10	3,6—150	320
Schwenken 8		S 180	180	beliebig	max. 325	50
Werkstück- bewegung 9		DT 360	Drehen 360 Schwenken 90	vertikal 12 horizontal	Drehen und Schwenken 3,6—150 13	500

Modular system ZIS 995 for welding robots

- 1 construction unit
- 2 positioning path
- 3 installation position
- 4 positioning speed
- 5 load
- 6 translation
- 7 rotation
- 8 pivoting
- 9 work piece motion
- 10 arbitrary
- 11 horizontal
- 12 vertical
- 13 turning and pivoting
- 14 turning
- 15 pivoting

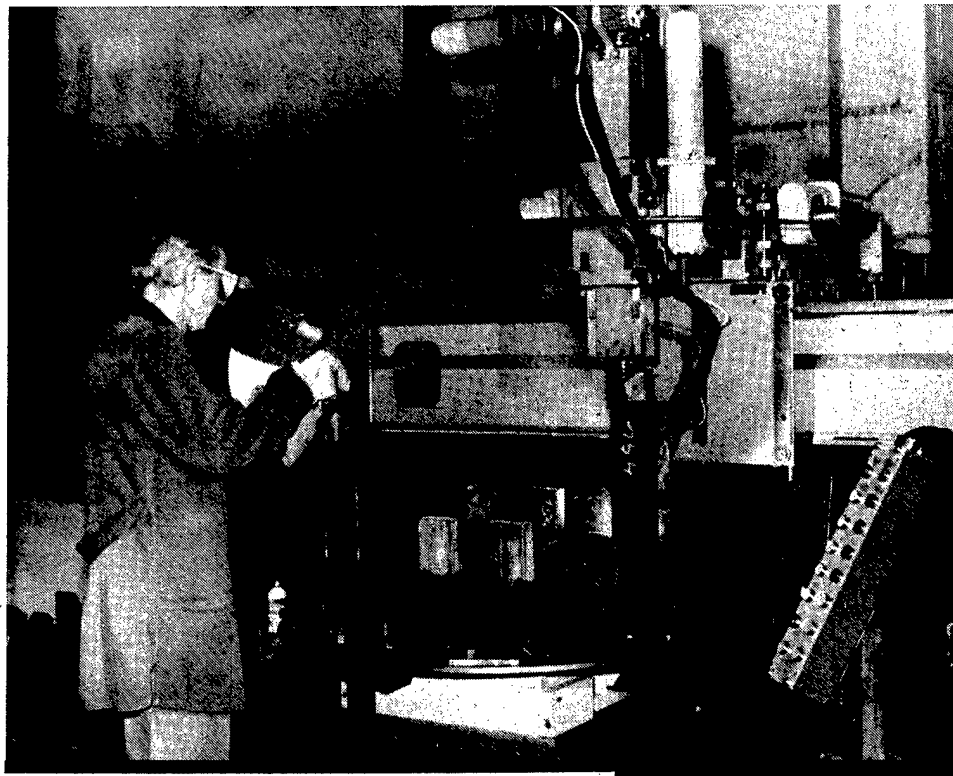

Arc welding robot R 5 ZIS 10-41

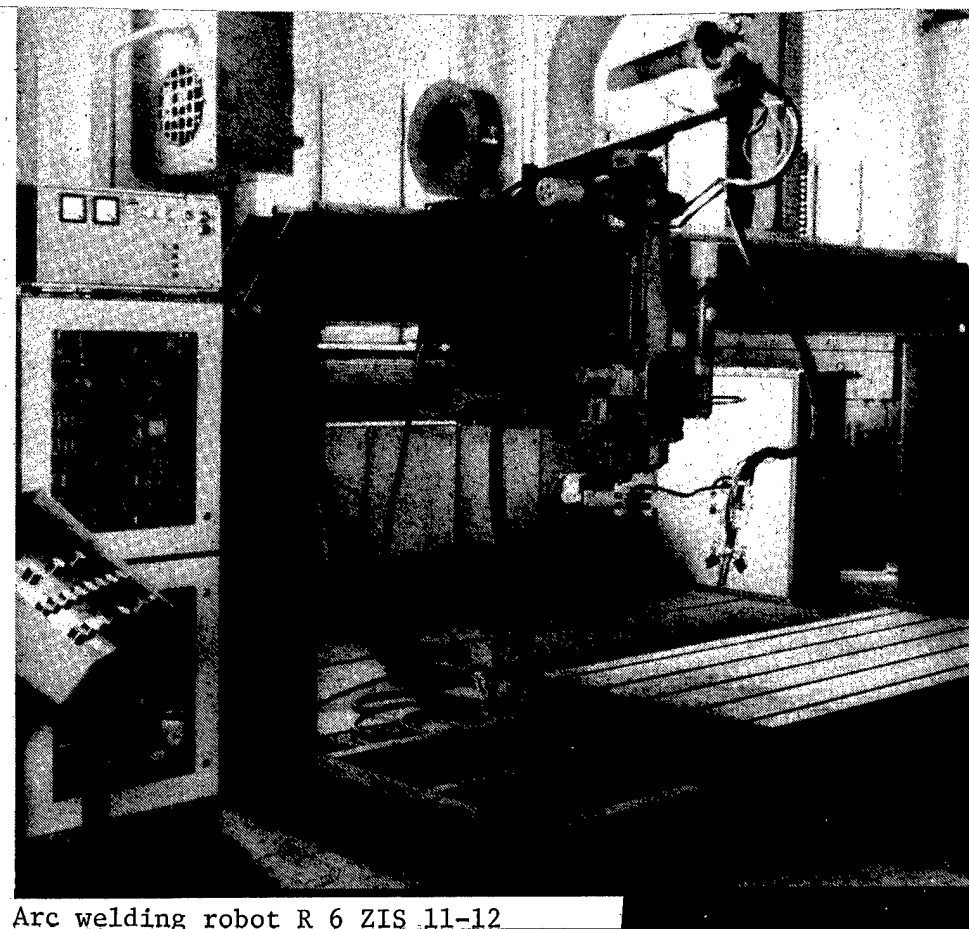

Arc welding robot R 6 ZIS 11-12

Arc Welding Robot R 6 ZIS 11-12

Development:

ZIS Halle

Application:

The welding robot R 6 is primarily designed as a trial model at ZIS Halle. By means of this robot, further applications are to be investigated under contract with industrial enterprises. It is equipped with position sensors for tracing the seam when welding long fillet seams.

The modules ZIS 995 were used for constructing the moving apparatus.

Spot Welding Robot R 7 ZIS 10-70

Development:

ZIS Halle and VEB Automobile Works Zwickau

Application:

The welding robot is used to weld body parts. The component is brought into the welding position by an indexing table which works in an oscillating cycle. While the 18 spots are being welded, a new component is inserted and clamped.

The modules ZIS 995 were used for the moving apparatus.

Spot Welding Robot R 3 ZIS 986

Development:

ZIS Halle and VEB Automobile Works Zwickau

Application:

The robot welds body parts for passenger cars. Two components, each with 30 spots, are always welded at the same time. The work pieces are received by an indexing table, which works in oscillating cycles. Since the welding spots lie at various seam levels, the receiving unit for the welded parts is equipped with a fourth degree of freedom.

The modules ZIS 995 were used for the moving apparatus.

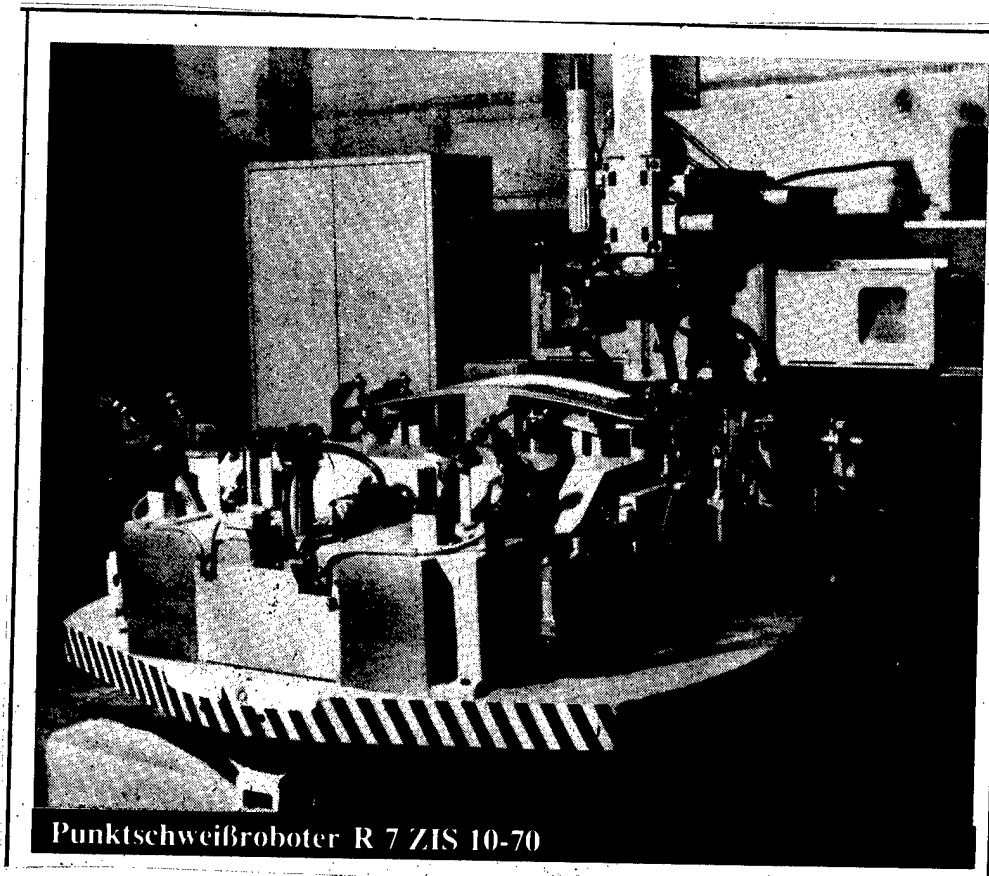

Spot welding robot R 7 ZIS 10-70

Welding Robot Component System

East Berlin TECHNISCHE GEMEINSCHAFT in German Vol 29 No 12, Dec 81
(signed to press 30 Oct 81) pp 33-35

[Article by Dr. G. Hesse, engineer, GDR Central Institute for Welding Technology (ZIS): "Welding Robots From Component Assemblies"]

[Text] The successful use of industrial robots in our industry depends significantly on how successful is the construction of industrial robots in the building of means for improving efficiency on the part of the combines and enterprises. The following contributions make available for this experience and pointers, and describe important components, such as, for example, controls, drives, and peripheral equipment.

Programmable industrial robots are currently being introduced into the welding operations of the GDR. They are mainly produced in the departments for constructing means to improve efficiency, in the combines and enterprises. In this sense, the Central Institute for Welding Technology (ZIS) will make an essential contribution towards automating about 30 to 40 percent of all welding work in the GDR by 1985. Already at the present time, long fillet welds and butt welds are mainly welded automatically. About 300 additional automatic welding machines are put in operation annually. Just for CO₂ welding, the proportion of welding wire that was welded automatically has in recent years risen to 15 percent of the total.

The main application areas for welding robot technology presently are the many short fillet and butt welds, which generally are still executed manually. The welding robots will then automatically move the welding torches, the welding tongs, and the welded parts. As regards positioning and process sequence, they can be programmed.

The technical-economic success of a welding robot depends mainly on the correct technological task definition and its solution. Thus, the ZIS has available the results of component analyses which indicate the points that must be emphasized for the use of arc welding robots (1). In summary, the following use conditions emerge:

Seventy-five percent of the welded parts are produced in annual unit numbers between 100 and 50000, 85 percent have a weight of less than 40 kg, 80 percent of the welded seams are fillet seams, 70 percent of the welded seams have weld heights of 3, 4, or 5 mm, 40 percent of the welded seams are straight, 40 percent are circular, and 85 percent are shorter than two meters.

Consequently, great efforts must be undertaken to use welding robots even in small and medium-series production, in an economic manner. At the present time, welding robot technology is used in already existing production. During the next years, the use of welding robot technology, however, must be technically prepared with new or improved designs in entire production sections. Several working robots then work in production nests or on assembly lines. It appears that welding robots entail further industrial robots. Only when welding robots can perform up to 80 percent of all welding work will economical solutions result (2). The use limits are frequently drawn by the price for robot technology. For this reason, the correct technical concepts must be chosen. Robot development which is matched to the requirements of the national economy requires a simple and cheap construction. Only as much technology may be used as is necessary to solve the anticipated task.

In the ZIS, the development of welding robots began as the development of couplable modules to form the system ZIS 995. Welding robots with rectangular main axes have many advantages for the welding of numerous straight or circular seams when joining sheet metal, sections, or tubes. These advantages are the following:

The largest possible number of assembly variants of one to eight axes as well as a subdivision of the axes to move the welding torch to the welded parts;

parallel position of the coordinates to the welded seams; in this way, the control, the programming, and the use of sensors is simplified;

no direct limitation of the working space; this is especially important when welding larger parts. A portal mode of construction makes possible work on several welding devices which lie next to one another.

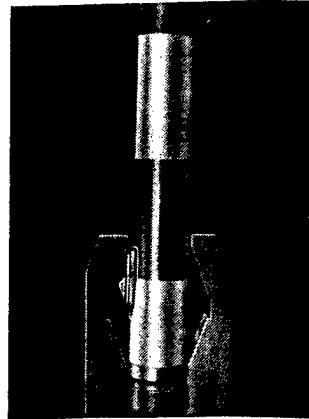

The assortment of ZIS 995 modules consists of six translational units (T100, T250, T400, T1000, T2800 and T6300), one rotational unit R 360, one pivoting unit S 180, and one rotation and pivoting unit. The mechanical axes have electromotor positioning drives with transmissions and toothed rods. The paths are measured with incremental transducers of the type IGR in connection with precision toothed rods. Besides the number of individual axes, e.g. T_x , T_y , T_z , for the base body, the disposition of motional axes plays an essential role in the multiple design of the kinematic frame with respect to the motional program and with respect to stability (Figure 1). In the design of mechanical electrical modules, the following orientation prevailed:

The implementation of all necessary functions for resistance, spot and arc welding robots;

use of modules fabricated in the GDR;

creation of simplified solutions which make possible in-house construction in the departments for constructing means to improve efficiency within the enterprises;

use of existing experience, e.g. with the module set ZIS 650.

These mechanical modules are operated by the control ZIS 10-36 which likewise has a modular structure. The complete variant controls a welding robot consisting of the modules ZIS 995 with six numerical axes, two secondary axes, and two positioning sensors (3). The control works by the principle of a numerical point-distance control and positions the welding tools along axis-parallel straight lines of the coordinates X, Y, and Z as well as about their rotation angles A_x , B_y , C_z .

To compensate component tolerances, two positioning sensors (e.g. Type ZIS 10-67) can be connected (Figure 2). The ZIS Halle is pursuing development in industrial testing of various sensor systems for welding robots (4).

The development result fulfills the main requirements for welding robots. Over 70 enterprises already use this development. The first resistance welding robot (5) was used industrially since September 1977 and the first arc welding robot (6) since October 1979.

The following economic results were here achieved (6):

Use of 469 TM/A (thousands of marks per year); saving of 3 AK (man years).

Furthermore, the following advantages resulted, among others:

Increase of production quality by essentially eliminating the subjective influences of the welder;

improvement of the working and living conditions of the welder by relieving him from heavy physical work and monotony;

secondary working times, which strongly load the capacities of the enterprises both organizationally and economically, could be reduced.

The spot welding robot ZIS-R 7 (in this connection see TG 7/80, page 21) is used for welding car body parts (5). The moving apparatus has only four axes available (T 2800 shortened, T 1000, T 4000, R 360). Included in this welding-device technology is a robot spot welding tong ZIS 10-80, a coupling unit with collision protection, a pressure converter ZIS 579 with a maintenance unit, a high-power transformer, a welding-process control Eltros II as well as hoses and high power cables (product group: resistance welding, combine VEB LEW (Locomotive Construction - Electrical Engineering Works) Hennigsdorf).

The arc welding robot ZIS-R 14 (Figure 3) can be used for the MAG welding of various small parts up to a weight of 30 kg. The torch is guided by three translational and one pivoting axis (T 1000, T 400, T 250, S 180). Two indexing tables type DT 360 are used to receive the welded parts. They pivot or rotate the parts into a position that is favorable for inert gas welding.

The following belong to the welding device technology: an inert gas welding torch, a coupling unit with collision protection, a wire advance unit, a welding rectifier (e.g. G 500 VC), an arc welding control ZIS 11-41, sensors for the welding process or the welding position (as required) as well as lines, hoses, cables, and cable mounts (product group: arc welding, VEB Welding Technology, Finsterwalde).

The objective of further development work is to improve the controls with sensors (e.g. deployment of the IRS 650). This makes possible rapid reprogramming for smaller block sizes (several times per shift), simplified programming (software) by using sensors at the component (the robot "recognizes" significant points at the welded part, such as e.g. the beginning and end of the seam, the position of the component with respect to the main robot axes, etc.), an increase of reliability, and the self diagnosing of troubles at the robot and in the welding process.

The development steps on the mechanical systems themselves will be minimal. What is required is partly higher speed of the axes in fast motion. Further requirements of the development are the conjunction of the operations of transportation, assembly, joining, and welding, as well as the use of several welding torches.

Bauteile 1	Hauptbewegung 2			Zusatzbew. 3		Werkstückbew. 4		Roboter 7	
	Translation			Rotation	Trans.	Rotat.	Drehen u. Schwen		Drehen
	T 2800 / 6300	T 1000	T 400	R 360	T 100/ 250	S 180	5		6
	1 T 2800	1	1						
	1 T 2800	1	1	1					
	1 T 2800	1	1	1					
	1 T 6300	2	1	1					
	1 T 2800	1		1		1			
	1 T 2800				1	1			
	1	1	1	1		1			
	1 T 2800	1	1			1	1		

Figure 1. Design of the kinematic structure with respect to the motional program and stability

- 1 component
- 2 main motion
- 3 supplementary motion
- 4 work piece motion
- 5 turning and pivoting
- 6 turning
- 7 robot

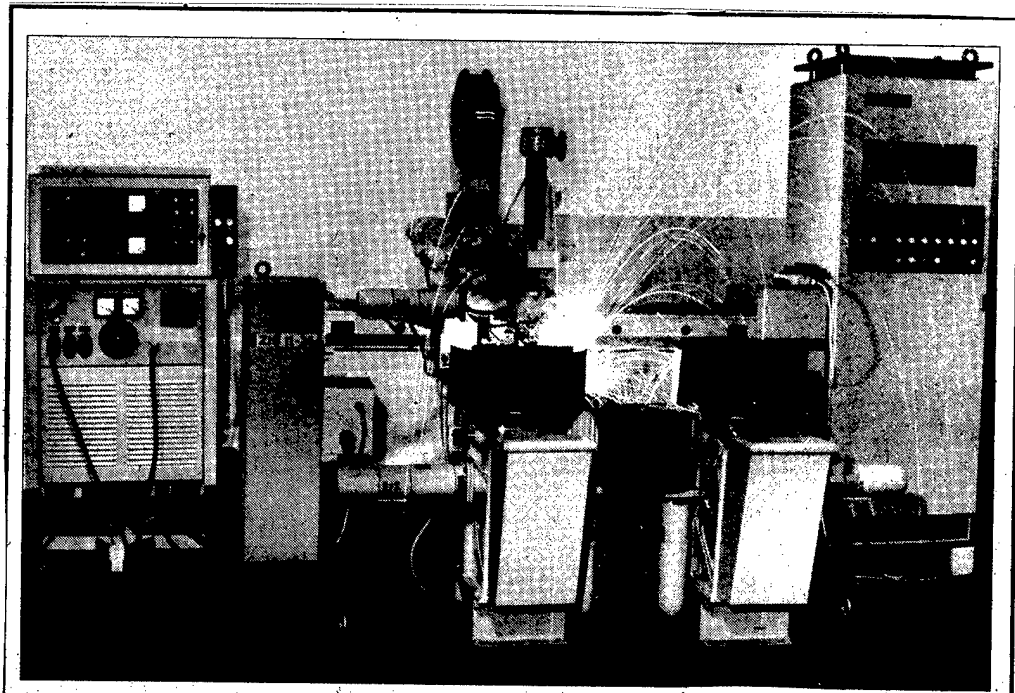

Figure 3:
Arc welding robot ZIS R 14

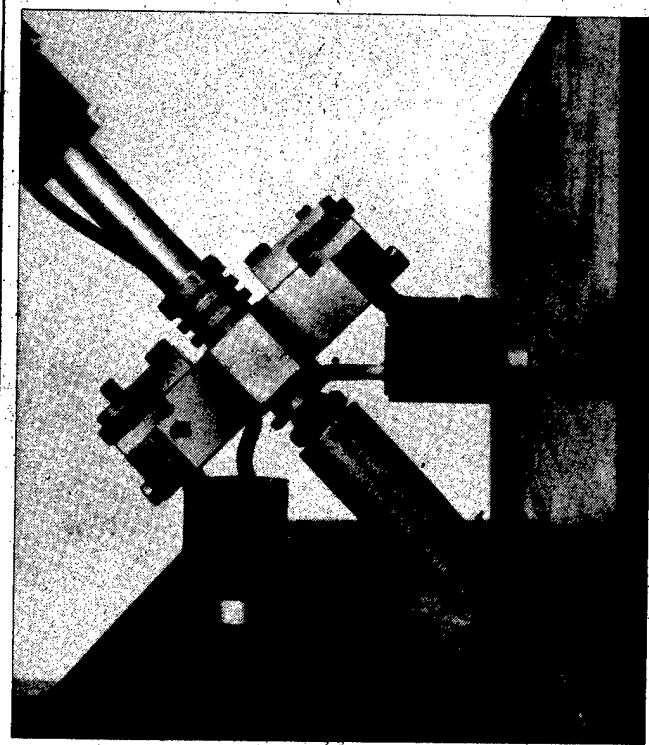

Figure 2: Welding torch with sensor

The following requirements are decisive for the further technical-economic strategy for welding robot development:

The technological task must stand in the foreground when evaluating the deployment of welding robots;

robot development according to overall perspectives of the national economy (i.e. simple, cheap, and only as much technology as is necessary);

improvement of the working and living conditions at selected work stations;

liberation of two to three working forces per robot;

amortization of the investment in less than three years;

wide inclusion of as many combines, enterprises, and development agencies as possible, to create a powerful construction for means to improve efficiency, for the introduction of robots and as a basis of a complex mechanization and automation as well as further use of individual robot modules;

use of as many more welding torches or welding tongs as possible in one welding robot, so as to achieve high productivity;

reduction of auxiliary times by peripheral units such as oscillating tables, indexing tables and longitudinal cycle conveyors, and the use of insertion devices for loading.

BIBLIOGRAPHY

- [1] Lehmann, O., Naumann, E.: Technical component analysis. ZIS Mitteilungen (ZIS Reports), Halle (Saale) 21 (8) 794-803, 1979.
- [2] Gilde, W.: Robots from a module set. EINHEIT HEFT (UNIT ISSUE) 9/81, p. 887-889.
- [3] Göttert, W., Ströfer, M.: Control and drives for welding robots from the modules ZIS 995.
- [4] Schulze, K.-R., Faber, W.: Sensors for welding robots. ZIS Mitteilungen (ZIS Reports), Halle (Saale) 21 (11) 1234-1240, 1979.
- [5] Frankhanel, F. et al. Industrial experience in the use of welding robots in car production for the Trabant 601, SCHWEISSTECHNIK (WELDING ENGINEERING) Berlin 30, 10, 436-440, 1980.
- [6] Herte, K., Rischka, D.: Experience in the use of the first arc welding robot ZIS 10-41 (R 5), SCHWEISSTECHNIK (WELDING ENGINEERING) Berlin 30, 9, 408-410, 1980.

IR 3-P Loading Robot

East Berlin TECHNISCHE GEMEINSCHAFT in German Vol 29 No 12, Dec 81
(signed to press 30 Oct 81) pp 39-40

[Article by B. Greger, engineer, and Dr. G. Mittag, Zwickau Engineering College:
"Construction and Use of the IR 3-P"]

[Text] For many years, the Zwickau Engineering College and the VEB Sachsenring have been collaborating in various areas. It therefore appeared close at hand to bring over into practical application also the research results of the IH (Engineering College) in the area of robot technology in this enterprise.

Since short deadlines existed, it was suggested to coordinate the already designed pneumatic industrial robot IR 3-P with the production requirements of the enterprise. At the same time, the associated technological unit had to be adapted to the most recent conditions and the required peripheral equipment had to be created. The objective was to improve multi-machine operation in the area of transmission production. The special application resulted from the operation of two gear-wheel shaping machines.

The industrial robot IR 3-P (see also TG 2/80, p. 28) is constructed according to the DSS (Data Storage System) principle. The basic device has available three degrees of freedom. Further possibilities of motion, such as e.g. gripping or turning the gripper hand, are possible and provision is made for them in the control. At the central MMM (Exhibition of Tomorrow's Masters) in 1981, the IR 3-P was also shown with a double gripper.

Further data are the following: x-axis = 315 mm; z-axis = 200 mm; c-rotation = 220°; running speed = 1 m/s. To this are added 44 (57) program steps which - inter-linked through a plug panel - allow the free programming of the industrial robot.

Basic investigations and determination of the main data as well as preliminary drafts can be easily integrated into the instructional process of a college. On the other hand, the development and detail work should take place primarily in the manufacturing operation. Only the long years of close collaboration between the VEB Sachsenring and Zwickau Engineering College and the resulting precise information concerning production possibilities allowed the deviation from this principle.

The basic unit was constructed in the VEB Sachsenring, the control at the Zwickau Engineering College (IHZ): A division of work which resulted from an examination of the available capacities and professional capabilities. It lay close at hand to use the laboratories of the IHZ to design the control and to verify experimentally several special features of the pneumatic plug-in panel programming.

In designing the industrial robot IR 3-P, the starting point was a broad use spectrum. This meant that even the special conditions, for example the food-stuff, leather, and ceramic industries, had to be included in the considerations. Thus the working rooms of the production means, the elements being handled, and the storage of elements, both as regards their shape and their dimensions, are quite

different. The basic motion of the IR 3-P is translational (SSD), since standardized piston drives are used. Consequently, follow-up use by inhouse construction is possible even by medium enterprises. The basic structure is composed of modules which are designed so that they can be used individually, but can also be assembled in such a fashion that a reduced degree of freedom results. Where leakage oils have a negative influence on the material being handled or could even destroy it, a hydraulic drive is not applicable. The short operating times and the high loading speeds that become necessary thereby consequently led to the choice of a pneumatic drive.

The connection to the compressed air network had as its consequence that the control was also designed pneumatically. On the basis of the existing control, the VEB Control Works Dresden developed a special variant for the IR 3-P and tested it. This is now available in a mature fashion to the follow-up users.

Between the industrial robot and the control there exists a loosable electrical connection. Thus the distance between the two can be freely selected. Furthermore, it is possible to connect an electronic control. The user who wishes to use only individual modules can indeed connect the complete control from the VEB Control Works, but he is better advised to utilize his own control (possibly at the same time as a coupling unit for the entire production cell).

The handling cycle is programmed through a plug-in panel. By means of hose connections, the program can be inputted step by step. Adjustable damped fixed stops allow a positioning accuracy less than 0.1 mm. This accuracy is especially reached by the fact that all guide elements can be adjusted free of play.

The high utilization of industrial robots with operating times $t_o > 30$ s is derived from multi-machine operation. However, a condition is a large number of program steps and the positioning at several points per axis. The IR 3-P, with its 44 (57) program steps offers high flexibility for this.

However, in the x-axis and in the c-rotation, three positions each can be adjusted, and in the z-axis, two points are adjustable. Consequently, when setting up a production cell, one must note the following points:

The industrial robot is to be disposed within the technological unit, if possible, so that no operating points lie on the forward pivoting radius of the robot. Corresponding adjustment elements underneath the device make possible an adjustment. Already in designing the production cell, measurement pins or similar control devices should already be provided for this. The like also holds for coordinating the height. The work piece support surface in the storage unit is not always a reliable basis for an exact positioning of the work pieces in the gripper hand. In a technological unit for processing pinion shafts, for example, the central boring is the decisive surface. The placing of parts on tips in the plate storage would lead to complications. However, to fulfill the requirement "bring parts for gripping to the same height", a lifting device at the storage output point takes over the positioning of the parts in the storage unit.

Residual cooling and lubricating fluids at the work piece cause severe contamination of the production cell, unless appropriate disposal equipment has been provided in advance in the handling area. The waste handling is especially important. Not only

large chips lead to interferences, but also small dirt particles frequently interrupt the automatic execution sequence.

Experience has shown that only a good process study and a thorough error analysis of previous production allows a reliable design of the technological unit with industrial robots. Also, the operating and monitoring forces should already be familiarized with its special features, while the unit is being constructed, so that they will have a feeling of responsibility and will thus achieve good utilization.

Industrial robot IR 3-P with round storage unit in a production nest with two roller shaping machines (plant photo).(caption)

8348

CSO:2302

CONTROL SYSTEMS FOR INDUSTRIAL ROBOTS DESCRIBED

East Berlin TECHNISCHE GEMEINSCHAFT in German Vol 29 No 12, Dec 81 (signed to press 30 Oct 81) pp 42-44

[Article by Dr H.-J. Bartsch, VEB Karl Marx Numerik (Numerical Controls) Enterprise; Dr R. Waetzig and W. Barth, Karl-Marx-Stadt Machine-Toolbuilding Research Center: "Controls for Industrial Robots"]

[Text] The VEB Numerical Controls "Karl Marx," Karl-Marx-Stadt, is responsible for developing and manufacturing controls for serially produced industrial robots. It has the task of developing controls for satisfying the greatest possible number of recognized end applications and also of offering basic systems which factory engineers can employ in their own development efforts to satisfy future user application requirements. The following control types are now available or are under development:

PS 2000/1: programmable control for manipulators;

IRS 2000: numerical point-to-point control with manually adjustable position reference values for controlling hydraulic servoactuators;

IRS 600: numerical point-to-point control with indirect teach-in for inputting position reference values in cylinder coordinates for controlling hydraulic servoactuators.

IRS 650: numerical multipoint or stepped-path control with indirect teach-in for inputting position values in hinge coordinates for controlling electrical servodrives (expansion to continuous-path control is planned). It is expandable for direct lead-through-teach (LTT) mode of inputting space position values for controlling hydraulic servodrives.

The PS 2000/1 is a memory-programmable control without NC axes in a single cassette with a 4 kbyte semiconductor program memory (EPROM U552). It is expandable to a maximum of 128 I/O channels.

The control can be used for manipulators with bang-bang control of axis motions and a fixed working cycle. The read-only memory does not permit teach-in programming of the logic steps. Programming is accomplished with the aid of a special plug-in programming unit.

The IRS 2000 was derived from the memory-programmable control PS 2000 (the large variant of the above mentioned PS 2000/1) through expansion by 1 or 2 numerically-controlled, position-controlled axes plus operating equipment. The control is designed for the painting robot IR 2/S II and can be coupled with 1 or 2 machine tools and associated peripherals.

The steps for the individual processes are stored in the semiconductor memory of the PS 2000 (EPROM U552, 4 kbyte max) wherein a maximum of 12 different programs can be input via the programming unit and can be selected by the program selector switch. Cyclic logic is used with a maximum cycle time of 18 ms. Up to 230 position reference values can be manually set into precision potentiometers as voltage values between -15 and +15 volts. The control picks off these voltages and solves the motion problem of the industrial robot by comparing the present value to the command value. In the process the present value is proportional to the voltage picked up from the linear potentiometers. The controlled parameter is the oil flow out of the servo-valve; acceleration behavior is determined with electrical ramp generators.

In addition to the 2 NC axes, 3 additional limit-switch-controlled axes can be added. All motions can occur simultaneously. Two counters, 8 time steps; 3 modes of operation (manual, stepwise automatic, automatic) with corresponding operating elements; 156 I/Os for the robots and 144 I/Os for the peripheral equipment are additional features. Because of the EPROM memory, the IRS 2000 is not suited for teach-in programming, a feature which limits flexibility. Increasing the number of programs beyond 12 requires changing the memory boards.

The IRS 600 (TGL 38758) was a joint development involving collectives of the Research Center of the Machine-Tool Enterprise and the VEB Numerical Controls "Karl Marx," with the latter being the manufacturer. User factories will be able to requisition from VEB Berlin Machine-Tool Factory as central robot manufacturer complete robot installations including controls.

Following the international trend, the IRS 600 is designed for computer control (Robotron K 1520) with teach-in programming. The positioning capability includes the simultaneous operation of--depending on expansion level--1 to 3 position-controlled axes; 1 additional cam-controlled axis with stepless drive plus provisions for additional normal cam axes. The IRS 600 is enclosed in an ECS cabinet with dimensions 600 x 600 x 1,800 [mm presumed] with an IP 54 protective system; a computer section; a programmable I/O control (PC); a power supply; a logic section and a power section. The unit is operated via a flexibly connected teach-in key pad which can also be plugged into the front panel of the cabinet (Figure 1). The control is of modular design with respect to the major components: computer section, I/O control and logic power supply.

The IRS 600 employs a dual-bus system consisting of the computer bus and the I/O control bus (Figure 2).

Computer Bus: The following circuit-board component groups (KBG) feed into the computer bus: computer memory K 1520 with central processor unit (ZRE)

K 2521; 2 CMOS memories K 3521 with 4 kbytes each; EPROM memory K 3820 with 16 kbytes.

Position Control Section: The positioning processes are effected with computer-controlled position control circuits.

Sensors: Phase-cyclic sensors are used. Sensor control and analog signal conditioning take place in the basic modules M 1 (using inductosyns) and M 2 (using resolvers). The digital section and the bus connector are located on KBG ME 1, 1 group for each sensed axis.

Output Section: Control of the stepless control drive is accomplished with KBG DA 2 which carries 4 D/A converter channels. An excitation signal of +/- 50 mA is employed for the direct control of servo drives; the output signal level is +/- 10 V for electric drives.

Service Unit: KBG SE makes possible computer service manipulations and a directed fault diagnosis in which the fault-search routines are initiated by inputting program numbers. This form of diagnosis is augmented by the automatic analysis of the initial transient each time the control is turned on. The SE card contains 4 input keys, a selector switch, a 6-place LED display and 8 luminous diodes.

Interface Controls: For program archiving or program input, the IRS 600 possesses a connector for a tape reader/puncher on circuit board AS 4 which connects with a plug on the side panel of the cabinet.

An additional interface control (KBG AS 3) couples the control bus. The modules of the digital I/O control are operated on a separate PC bus which, analogously to the CNC 600 control, is connected with the computer bus via an optically decoupled bus adapter.

Digital I/O Bus: This bus is designed as basic control equipment which can be expanded in accordance with user requirements within reasonable limits. All modules are equipped with front panel plug-in cards employing single-bit-connection technology with the bit display being realized with luminescent diodes.

Input Modules: Contactless input designed for 12 to 24 V and 15 mA is employed. The following modules are used: KBG PE 1: 16 bit; KBG PE 3: 32 bit; KBG PL: 16 bit (with interrupt behavior).

Output Modules: For controlling robots and operating functions, contactless technology is used throughout, while for remote-control coupling the following additional contact component groups are used: KBG PA 6: 8 bit, 2.5 A, 24 V (contactless); KBG PA 7: 16 bit, 200 mA, 24 V (contactless); KBG PA 3: 8 bit, 220 V, 70 VA (circuit-board relays).

Input and Operating Elements: Installed on the cabinet are the main switch as well as buttons for control voltage, hydraulics and emergency disconnect. Programming and operation of the control is accomplished by the teach-in key

board which is attached to the PC via a multiplexer. The key board contains on two KBGs the functional complexes: programmable displays, numerical input, function keys, command input, service keys, selector switch and normal and emergency disconnects.

Input of user software (process programs and facility data base) is accomplished by the user in accordance with the IRS-600 operating and programming instructions. Detailed knowledge of the control's functional software, which was worked out during development and sold to the user stored on EPROM memory chips, is not required. The input of robot programs for painting one to seven machines can be accomplished in the following modes: teach-in, manual, manual with realization of the associated robot movements and by tape reader.

Up to 99 programs stored in a 5.5-kbyte battery-buffered CMOS memory region are addressable. Manual input of a normal painting program into the IRS 600 takes about 3 minutes.

Whereas earlier controls were designed mainly for painting and handling tasks, the IRS-650 control now in development will be used for operating highly articulated industrial robots (IR 10, IR 60, ZIM 10, ZIM 60) designed to do basic technological tasks.

The IRS 650 is a numerical control system of the 600 generation derived from subsystems of earlier designs but incorporating microcomputer technology for position control of up to six axes. Being developed alongside the controls themselves are the TDR 100 actuator and the RSM 10 and 60 positioning motors to serve as servo drives. The maximum required 6 position controllers are housed in the cabinet. The control contains power-buffered CMOS RAMs as memory circuits. Memory space available for teach-in programming is 10 kbyte. Programming is accomplished via a portable teach-in key pad per instructions provided. Filing and input capability is provided.

Planned are 32 (20 mA) digital input and 32 (100 mA) digital output channels; as power outputs 8 KBG channels at 24 V DC, 1A (5 A transient current) are available. The selectable modes of operation are automatic, programming, set up/manual, reference point loading, program input and program output. The axis speeds are calculated proportional to the distance to be traveled along the separate axes.

Caption for Figure 1. Flexibly attached teach-in keyboard

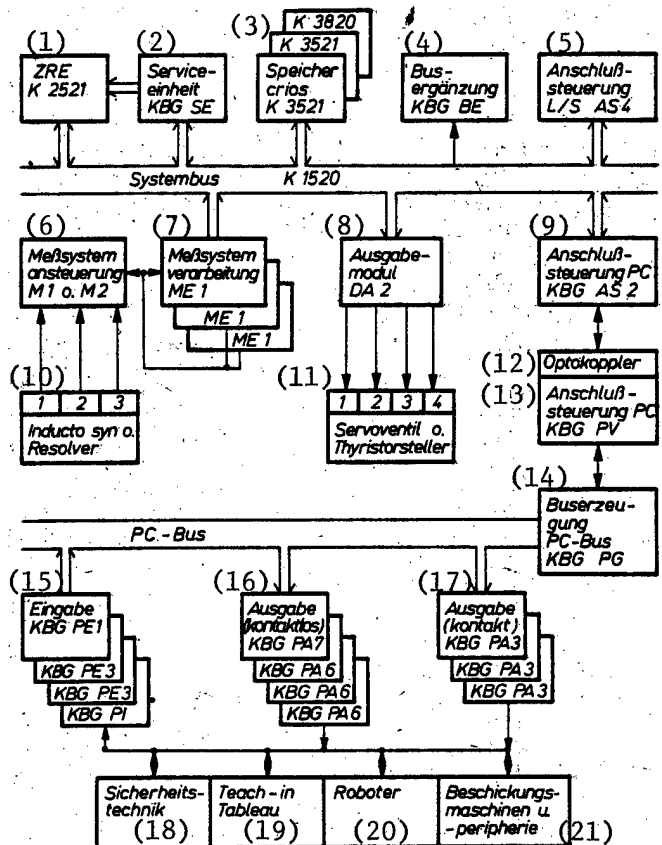

Figure 2. IRS 600 dual bus system

Key:

- | | |
|--|---|
| 1. Central processor unit | 12. Optical coupler |
| 2. Service unit | 13. Programmable control interface control unit |
| 3. Memory units | 14. Bus drive, programmable controller bus |
| 4. Bus expansion unit | 15. Input unit |
| 5. Reader/puncher interface control unit | 16. Output unit (contactless) |
| 6. Sensor control unit | 17. Output unit (contact) |
| 7. Sensor signal conditioning unit | 18. Assurance functions |
| 8. Output module | 19. Teach-in keyboard |
| 9. Programmable control interface control unit | 20. Robots |
| 10. Inductosyns or resolvers | 21. Painting machines and peripheral equipment |
| 11. Servovalves or thyristor power tubes | |

9160
CSO: 2302/10

ARTICULATED ROBOTS FOR TECHNOLOGICAL PROCESSES DESCRIBED

Series Production for 1983

East Berlin TECHNISCHE GEMEINSCHAFT in German Vol 29 No 12, Dec 81
(signed to press 30 Oct 81) pp 28-29

[Article by Dr J. Schniese, VEB Engineering Enterprise for Agricultural Machinery Technology of the Fortschritt Agricultural Machinery Combine, Leipzig: "Robots for Technological Processes"]

[Text] Industrial robots can perform a broad spectrum of process-flexible working operations for tool and work piece handling, with resulting specific technological, technical, and economic aspects. This requires that industrial robots with an articulated design also be made available to solve the extensive and different tasks of our industrial enterprises.

On the basis of researches on the use and design of articulated robots as well as in the evaluation of international development trends, it has been recognized that industrial robots with an articulated design and with selectable drives can perform a large number of technical operations.

At this time, in the GDR, articulated robots with a handling weight range of 10 and 60 kg are being developed and produced in various types:

IR 10 E and IR 60 E by the VEB (state enterprise) Combine on Progressive Agricultural Machines in the Ministry for General Machine Construction, Agricultural Machines, and Vehicle Construction,

ZIM 10, ZIM 60 and ZIM 60 L by the VEB Central Engineering Operation of Metallurgy (ZIM) in the Ministry for Ore Mining, Metallurgy, and Lime.

The abbreviations E and L signify "electrical drive" and "light construction mode".

By means of the articulated robots IR10 E and IR 60 E of the Combine Progress, the design solution of the functional principle should be elucidated in more detail.

The following objectives had to be obtained while shortening the development time:

1983 start up of mass production of articulated robots in the combine operation VEB System Construction IMPULSA Elsterwerda, which corresponds to the advanced international state of the art, for whose production and use in the GDR there exist no interfering protective rights and in which no NSW (Non-Socialist Economic Area) components are used. For this purpose, a close socialist joint operation had to be organized with the previous generators of experience, the ZIM, the VEB Combine Electrical Machine Construction Dresden, the VEB Numeric "Karl-Marx", Karl-Marx-Stadt, and Magdeburg Technical College,

On the basis of agreements that were confirmed for the general directives and agents of the ministries, the three development collectives, the VEB Engineering Enterprise for Agricultural Machine Technology, Leipzig (ILT), and the VEB ZIM, Automation Enterprise Leipzig, fulfilled their task with this objective for the Tenth Party Congress, namely the design and functional model construction of the type IR 10 E, IR 60 E, ZIM 10, ZIM 60 L. In parallel to this, a complex competitive agreement was concluded with the combines responsible for the supplier modules (microcomputer control, d.c. positioning drives, measuring systems, tables, etc.), under the management of the VEB Numeric "Karl-Marx". Thus, beginning in 1983, the need for these requirements will be secured. With the responsible Combine for Welding, Grinding and Deburring Technology that is appropriate for the IRs, as well as the ZIS, Halle, cooperative relations were initiated, so that the coordinated development work on the IR technology could become effective according to plan.

Design Solution and Functional Principle

The articulated robot is a process-flexible industrial robot with five degrees of freedom and/or rotational axes. It is composed of the following three main elements: mechanical system, control system, measurement and servo system.

The mechanical system is an articulated arm - IR, which converts the rotational motion of the motors into the necessary motions and thereby executes the following motional sequence:

Rotational motion of the IR in its base, forwards/backwards motion of the lower arm, upward/downward motion of the upper arm, vertical motion of the hand hinge, rotational motion of the hand hinge.

The kinematic structure of this articulated robot is determined by:

Three rotational hinges in the main axes (C-, B-, and H-axes),

two rotational hinges in the gripper axes (D- and E-axes),

statistical mass compensation through the equalization springs and masses,

auxiliary-energy-free securing of position in the case of "emergency off" for the upper and lower arm for the IR 60 E,

standardized mounting plate at the hand hinge for fastening technological tool and work piece equipment,

possibilities of limiting the final positions through adjustable contacts.

The driving systems consist of:

Electrical d.c. positioning drives for all the axes,

roller-screw drives for the B and H axes,

rotary transmissions with a high step-down ratio, with negative lift and with little play, according to the principle of the shaft transmission for the C-, m D-, and E-axes,

double crank drives for the D and E axes,

Articulated robots require a light construction consistent with obtaining high acceleration with small inertia. For this reason, all housing modules are designed in light metal castings. At the same time, short and light d.c. positioning motors were chosen for the drives which necessarily are arranged in an inertially unfavorable manner.

To shorten the final assembly and repair times, the individual modules of the IRs can be preassembled and are completely interchangeable. The control system consists of the following:

Microcomputer,

storage units (RAM, EPROM),

inputs and outputs for activating the robot,

logical switches for controlling the servo system of the robot,

interlocks and signals for peripheral equipment.

The measurement and servo system consists of low-mass, d.c. motors as well as servo amplifiers. The paths are measured with incremental transducers (incremental measuring methods: new measurement values are obtained by determining the change from the previous measured value) and by subsequent logical processing. As linkage element between the servo system and the mechanical system, one uses the shaft drive or a roller-screw drive. In this way, positioning accuracies of less than +0.4 mm are achieved.

The microcomputer takes over all the control tasks for the industrial robot, coordinates the interaction between the control system, the measuring and servo system, and the mechanical system, and also processes the process-related signals. The necessary basic programs, which guarantee the functional operation of the robots, are stored in read-only memories for the microcomputer.

The connection between the user and the control system is guaranteed through the operating and programming unit.

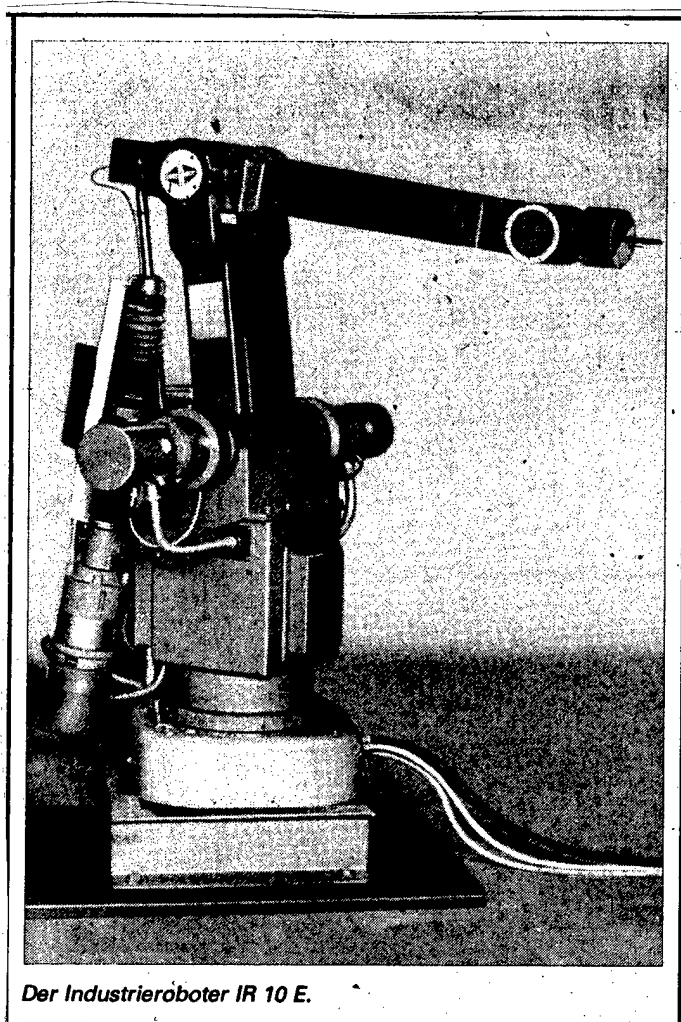

The industrial robot IR 10 E

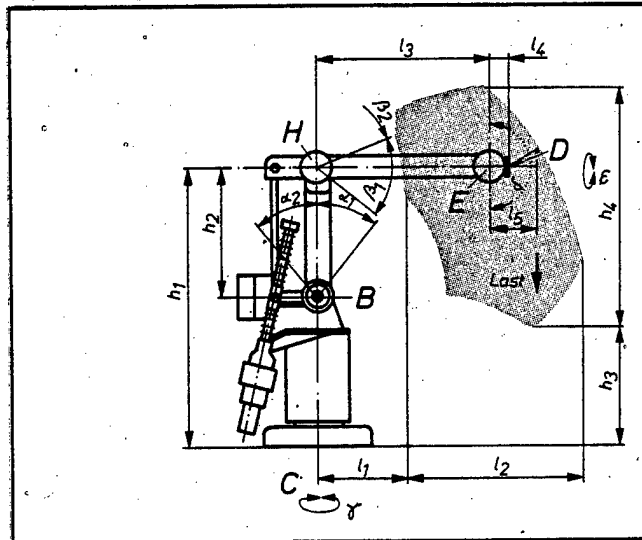

mm	l_1	l_2	l_3	l_4	l_5	h_1	h_2	h_3	h_4
IR 10 E	440	820	800	90	200	1350	600	550	1100
IR 60 E	760	1510	1300	210	400	1810	900	210	2000

Hauptachsen	C	B	H	E	D
Geschwindigkeiten	90°s^{-1}	1000mm s^{-1}	1000mm s^{-1}	100°s^{-1}	200°s^{-1}
Drehwinkel	γ	α_1	α_2	β_1	β_2
IR 10 E	330°	40°	40°	40°	20°
IR 60 E	330°	55°	20°	50°	10°
				δ	ϵ
				180°	360°
				180°	360°

The most important technical parameters, main dimensions, and working spaces of the IR E and IR 60 E

- 1 main axes
- 2 speeds
- 3 rotation angle

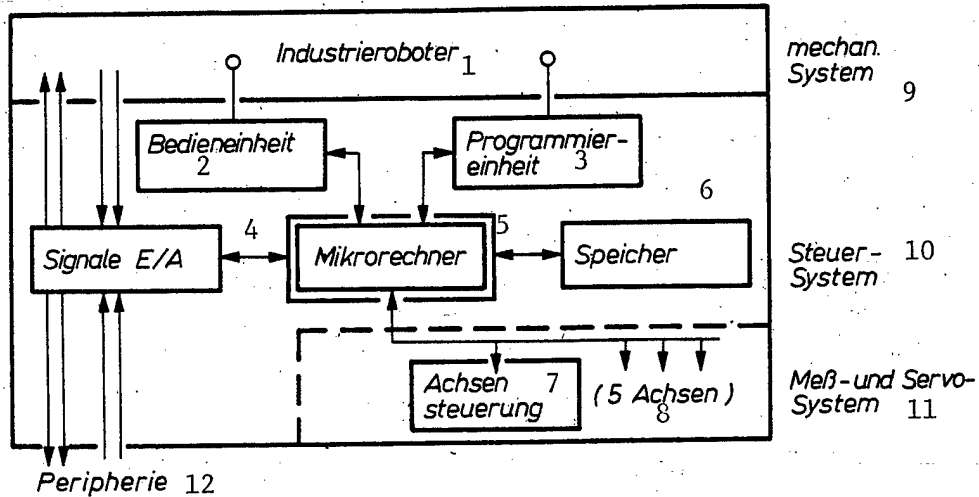

The interaction of the mechanical system, the control system, and the measurement and servo system

- 1 industrial robot
- 2 operating unit
- 3 programming unit
- 4 signals I/O
- 5 microcomputer
- 6 storage
- 7 axis control
- 8 five axes
- 9 mechanical system
- 10 control system
- 11 measuring and servo system
- 12 peripheral equipment

The function of the industrial robot to fulfill work sequences is implemented through a working program which must be generated by the user in accord with the intended working cycle.

Application Areas and Preparation for Applications

The anticipated application areas of the articulated robot with the electrical drive are the handling of tools and work pieces to perform technological operations, which require motions towards prescribed points in space along definite tracks.

Thus, the technical operations like resistance spot welding, arc welding, loading and extraction tasks, the finishing of castings, deburring, steel grid blasting, grinding, polishing, as well as joining and assembly processes can be implemented.

In its function as a combine management agency for IR application, the ILT (expansion unknown) is currently preparing the following technical applications to create typical solutions for a broad group of users.

IR 10 E: MAG (metal-active gas) welding

IR 60 E: resistance spot welding, grinding of cast parts, steel grid blasting of sheet metal parts, loading a scouring turntable PDS 2500 with large disc-shaped parts of ... (text missing) ... and in stack palettes (12 work pieces) with a continuous blasting process.

On the basis of the confirmed IR applications concept of the combines, goal-oriented work is proceeding on the conversion of the IR decision, specification manuals are being worked out for each application, and typical solutions are being created for recurring application areas.

The articulated robot, however, cannot be used as a universal unit for all IR applications.

Electrically Driven Articulated Robots

East Berlin TECHNISCHE GEMEINSCHAFT in German Vol 29 No 12, Dec 81
(signed to press 30 Oct 81) p 27

[Article by Dr M. Schwandtke, VEB Central Engineering Enterprise for Metallurgy, Berlin; chairman, Chamber of Technology Enterprise Section: "Electrically Driven Articulated Robots"]

[Text] In the industrial area of ore mining, metallurgy, and lime (EMK), the articulated robots of the ZIM series are being used as process-flexible industrial robots. These were primarily developed and produced in this area itself and are electrically driven.

They consist of the following components:

electrically driven manipulator in articulated construction mode with five degrees of freedom, all of which are freely programmable;

a control cabinet with a microcomputer MR 88, the axis control, the processing of I/O signals, as well as the necessary operating and programming units;

a manual operating console;

an operating system consisting of a software package;

a programming unit for inputting user programs;

read-only memory card;

a writing unit for the read only memory card.

The robot system is delivered to the customer as a functionally ready, programmable system with client inputs and outputs, without gripper technology and without peripheral equipment. The user has to design the industrial robot application that is tailored to his technological conditions and must implement his application. All combines in the EMK area participate in such problem solutions. Here, one combine always has responsibility for one solution. The application area of a ZIM industrial robot system to solve problems essentially comprise the following:

working out an optimal technology on the basis of the performance data of the robot system and the principle of variant selection;

planning;

development, design, and construction of peripheral equipment;

development, design, and construction of gripper technology;

qualification measures for the operation, handling, maintenance, repair, and programming of the system;

working out the user programs;

testing;

securing continuous operation for IR applications;

demonstrating the economic objectives and

organization of an exchange of experience.

On the basis of these activities, 30 typical problem solutions have up to now been implemented for applications of the ZIM industrial robot system.

With the problem solutions, a deployment collective was simultaneously always qualified, and it consisted of five to ten professionals. It is capable of implementing further applications. Our engineering enterprise is here oriented towards limiting the time interval from the availability of the robot system to the beginning of testing to three months, and towards implementing steady operation after a maximum further three months of testing.

It should be noted that, in application cases which require process development with the utilization of research and development capacities, these time intervals may be exceeded. The ZIM industrial robot system with the IR types ZIM 60 and ZIM 10 (industrial robots with a handling weight range of 60 and 10 kg) is a process flexible system, due to its universal usefulness and its large working space, which can be used in the most various technologies for semifinished or finished goods. Its special advantage consists in the free programmability of the five axes, for which the working programs can be generated by the indirect teach-in method and on the basis of algorithmic programming (background programming).

The background programming makes it possible to use the ZIM industrial robot system especially for batch and non-batch processes, where products with variable parameters and/or dimensions are to be deposited or taken up according to a prescribed model.

The application method for the ZIM robot system, which has been developed and practiced in the EMK area, guarantees that, with each industrial robot produced, there will be associated a production-effective IR application, which gives rise to follow-up use even beyond its own ministerial area, either completely or partly.

The ZIM industrial robots have hitherto essentially been used as technological stacking and servicing and loading industrial robots.

As technological industrial robots, the ZIM robots are suitable for arc welding of straight and curved seams, for grinding and deburring of cast steel parts, for grinding and drilling in subterranean lime operations, for the deslagging of zinc baths in non-ferrous metallurgy.

As stacking industrial robots, the ZIM IR system proves itself in the pyramid-shaped stacking and unstacking of cylindrical bodies, in the stacking of products of the fire-proofing industry, to set-up block-shaped stacks according to set-up diagrams and to occupy bogies, for the single- and multi-layer occupation of palettes with a prescribed set-up scheme, for the stacking of annular composites and products on palettes, for the stacking of filled cartons, the stacking of cubical packets of scrap, and for the stacking of rolled metal foil with a minimum length of 6 m, as well as for the packing and unpacking of boxes and containers with various materials.

As a servicing and loading robot, the ZIM IR system is finally used for the servicing of presses in powder metallurgy, for the servicing of hydraulic presses, for the servicing of NC machines (multi-machine servicing) and for the loading of V-groove pusher furnaces.

Two industrial robots in the VEB rolling plant Finow take over the ready-to-shift stacking of sections of every size. This physically heavy work previously had to be mastered by six rolling mill workers. A computer controls the use of the robot on the basis of a prescribed program. (Photo: ZB/Müller) (caption)

8348
CSO: 2302

GERMAN DEMOCRATIC REPUBLIC

PAINT-SPRAYING ROBOT FOR AUTOMOBILE FACTORY DESCRIBED

East Berlin TECHNISCHE GEMEINSCHAFT in German Vol 29 No 12, Dec 81
(signed to press 30 Oct 81) pp 30-31

[Article by L. Spreer, chief technologist, VEB Sachsenring Automobile Works, Zwickau: "Paint-Spraying Robot in Operation"]

[Text] Between 1976 and 1980, robot technology was introduced for spraying sanding sealer and finish coating as well as for applying the underseal in the VEB (state enterprise) Sachsenring Automobile Works Zwickau. This contributed decisively to productivity and especially towards ameliorating grievous working conditions. This technological peak performance, which even today comes up to international standards, was the result of socialist community work.

First of all, the engineers developed and tested variants of the finish coating for the paint treatment of the Trabant, using a simulation model. On the basis of the results achieved, this measure was taken up into the plan for science and engineering.

We used an hydraulic microprocess-controlled paint spraying robot with six degrees of freedom. The information memory, a magnetic disk, can store 3.2 million bits of information. A microprocessor interrogates all six motional axes 40 times per second and for each of these stores 20 bits of information.

The technological adaptation of this process consisted mainly in a precise positioning of the work piece with especially high reproducibility. What proved difficult was the specification of the program sequence concerning the position at the conveyor means in the spraying cabin. To facilitate program correction of the complicated processing sequence of an automobile car body, we subdivided the running sequence into two program steps. The programs were coded in accord with the pattern of the car body. The programming time of the car body is 2.8 minutes.

When installing the paint spraying robot into our existing spray-cabin system of the finish-coating lane II, the spray cabin width and the robot working range had to be adapted to the room size. For this purpose, the entire spray cabin tract had to be changed through add-ons, conversion of ventilation systems, control of the system, supply lines, and installation of a new conveyor system.

Special attention was paid to adherence to the legal safety tests and explosion protection tests of the paint spraying robots, especially with this application

variant for the spraying of coating materials of hazard class A.II and the pneumatic electrostatic spraying method.

The safety requirements for a maximum transition resistance of $10^{-6} \Omega$ from the work piece cost us considerable efforts. The problem arose because the car body can not be continuously driven on a wagon carrier truck past the paint spray robot with pneumatic-electrostatic spraying gun. With the proven safe ground through the spraying contact to the wagon carrier truck and to the slip contacts therefrom, we achieved the result that the charge carriers which reach the car body through the spraying method are drained off.

The paint spraying robots are equipped with color-changing units for the finishing lacquer to change the hue corresponding to the color program. Every color-change unit can undertake four color-change processes in accord with the assembly line run, on the basis of the existing paint circulating system.

The color-changing valve is connected to a solvent line which is fed from a paint pressure vessel to flush the lines clean between the color-changing battery and the gun. The color-changing process itself takes place in a program pause of the paint spraying robot according to preselection. The sequence is controlled electronically.

Spraying problems with the robots resulted from the fact that the amount of paint to be processed had to be held constant with high precision in order to avoid defective spots.

The preparation of the servicing, maintenance, and repair personnel required training at the actual object with accident and repair training. The training programs were supplemented by exercise programs in mass production.

In May 1976, we deployed the first robot and in June 1977 the second robot for applying the underseal. In May 1976, two spraying robots for the primer began to be used and in April 1978 two spraying robots for the finishing coating. With our spraying robots, we could increase the working productivity by 200 percent, and we could eliminate working forces from the stressful working conditions, as well as attain demonstrable quality improvements.

Articulated robot "TR 79 SZ", suspended design, involved in the wiping (degreasing) of raw car bodies. A joint work between the Mittweida Engineering College and the VEB Sachsenring Zwickau Automobile Works. (caption)

First series utilization of cover-lacquer spraying by means of robots in April 1978. An example of the fully automatic coating of automobile bodies in the VEB Sachsenring Zwickau Automobile works (plant photos). (caption)

8348
CSO: 2302

INDUSTRIAL ROBOT IRS 3000 FOR DROP-FORGING PROCESSES

East Berlin TECHNISCHE GEMEINSCHAFT in German Vol 29 No 12, Dec 81
(signed to press 30 Oct 81) pp 31-32

[Article by F. Lange, engineer, VEB Heinrich Rau Heavy Machine Construction Enterprise, Wildau: "IRS 3000 for Drop-Forging Processes"]

[Text] The use of industrial robots in drop-forging processes is a social concern because the working forces that are used for handling work pieces in these areas are exposed to great stresses from heat, noise, dirt, vibration, and not least of all from the heavy weights of the work pieces. Due to the short cycle times and the monotony associated therewith, these stresses are made still more urgent.

Within the framework of the further development of production processes, the use of robot technology poses the task of liberating these severely stressed working forces from these processes as a result of partial automation and of transferring to them more demanding working tasks.

The industrial robot IRS 3000 was produced by the VEB Heavy Machine Construction "Heinrich Rau" Wildau. It has available the necessary resistance with respect to the environmental stresses which occur in forging processes. It is suitable for handling work pieces in the weight range from 100 to 300 kg (net work piece weight). At the present time, it is the largest industrial robot in the GDR that is provided for mass production.

Its application possibilities are not limited to forging processes. It can be used wherever cyclic handling processes can be automated under constant conditions. In non-automatable processes, working difficulties can be reduced by using manipulator variants (synchronous manipulators), which can be delivered by the VEB Combine GISAG.

The manipulator with the type designation IMG 3000 is based on the basic unit of the IRS 3000 and is equipped with a manual control.

Work pieces with weights up to 300 kg require relatively large paths for their handling in the area of the working space of the production equipment.

By means of articulated arms, a nominal working field of 2500 mm respectively in the horizontal and vertical directions has been achieved. This will fulfill the requirements. Through the 300° rotational motion of the platform, which accepts

the articulated arms, the nominal working space takes up the shape of a hollow cylindrical segment, within which all the handling points must be situated,

The rotatable platform is mounted in a center pin that is connected with the base plate. The bearing play is compensated by pretensioned springs, so as to secure reproducible positioning accuracy. For the mounting of the articulated arms, which are designed rigid with respect to bending and torsion, one uses the same mounting principle.

All motional sequences are effected by hydraulic drives. They achieve speeds in the x and z directions, relative to the gripper connection point, of respectively about 0.75 m/s and, for the rotation about z, about 30°/s.

For the rotary direction, a hydro-motor with a series-connected step-down transmission - likewise with play compensation - is used, but for the rotational motion of the articulated arm, double-acting working cylinders are used.

By using low-friction gaskets, the stick-slip behavior (sudden transitions from adhesive to sliding friction and back) is reduced to a measure that is tolerable for the regulation process. To control and regulate the speed and motion sequences, the volume flow of the circulations is matched through their design status by means of servo valves as positioning elements.

The degree of cleanliness of the hydraulic oil, which is required for functional reliability, is secured by careful rinsing of the circulation. The compressed flow is generated in an hydraulic unit with a cabinet construction by means of rotary piston pumps.

The rotary transmission lead through is included in the center pin of the platform bearing. Through it, the compressed flow is conducted in a functionally reliable manner to the positionally variable working cylinders for the articulated arm and for the gripper functions.

The work piece gripper is connected with the articulated arm through bolts, so that replacement is possible without considerable expenditure of time. The design of the work piece grippers is determined by the work piece spectrum which forms the basis of the particular application.

To limit the design multiplicity, development of a gripper module assortment is anticipated, by means of which process-specific modifications can be tried starting from typical parts. The constant position of the longitudinal gripper axis remains preserved over the motional space by drawing upon a parallel guidance in the articulated arm system.

Relative to the gripper connection point, the IRS 3000 has available three positionally regulated axes (degrees of freedom), which can be supplemented by three motional axes at the gripper to provide a total of maximally six axes.

The gripper axes are preferably fixed-point controlled. This control convenience corresponds to the more general requirements for work piece handling in the application area.

The path information required for the position and speed control is obtained through rotary incremental transducers in combination with play-compensated measurement drives of high resolution. Relative to the gripper connection point, a reproducible position accuracy for the x and z axes of less than ± 1 mm is achieved and for the rotation about z an accuracy less than $\pm 0.1^\circ$ is achieved.

Processes with frequent change of the production task, e.g. drop-forging processes, require for their automation handling devices with high adaptability (flexibility).

This property exists through the control of the IRS 3000, which is freely programmable by the indirect teach-in method.

The control consists of the control cabinet with its logic section, the control computer, and the information memories, the portable manual control console, and the programming unit with display screen playback.

The basic software is delivered together with the IRS 3000, so that the user need only program the special information of the handling process step by step. The programs can be filed on read-only memories (EPROM), and are immediately available for re-use.

Information channels are available as inputs and outputs at the control to provide linkage with the production process or with the peripheral equipment.

The portion of conventional electrical equipment which is necessary to control the hydraulic drive is housed in a separate switch box.

The variable relationship of work piece space and area requirements of the IRS 3000 correspond to the conditions of concentrated arrangement of equipment, which is encountered in forging operations, and which is based, among other factors, on the favorable heat conduction of the work piece.

As is the case with the preparation of applications for industrial robots generally, the level of their implementation also decisively influences the achievable economic effect in the forging process. This starts from a thorough process analysis, which is followed, as a second working step, by design of technological processes in a manner which facilitates automation.

From this result, one derives the equipment structure, whose modelling concentrates on the functionally reliable peripheral equipment. Another point of concentration is to fix the gripper design.

For a specific application, a work piece gripper for automated work piece handling at a deburring press was developed and was designed so that, when the gripper fingers were pivoted inward, the forged part is grasped and, upon pivoting outward, the forged seams lie on the cutting plate, and could be taken up by their outer edge.

The gripper designs for forging processes are afflicted with problems because of the large form changes, high temperatures, and non-symmetric distribution of the masses of the forged parts. This presupposes close collaboration between the user and the manufacturer in the phase of preparing for use.

Clamping of the work piece under the conditions of high acceleration, which is possible only by a positive interlock due to the large form changes, requires relatively large holding forces which are generated through the working cylinders.

In order to exclude a loosening of the clamped work piece during a short interruption of the compressed flow, a pressure reservoir is present in the circulation of the clamping cylinders.

If existing production structures are automated, the geometric arrangement must generally be retained, since large-area foundations exclude a modification. As a result, the industrial robots to be utilized must be adapted to these conditions.

With the development of modular systems of gripper guiding drives (articulated arms), which will in the future be provided for the IRS 3000, these requirements will be fulfilled.

The use of industrial robots of the first generation, among which belongs the IRS 3000, presupposes that work pieces are furnished to the robot in a definite position and orientation, since the robot is not able to perceive an altered state in its environment and to modify the program adaptively.

The furnishing of work pieces in a defined position and orientation is possible only by functionally reliable peripheral equipment which is matched to the specifics of the work pieces. The development of this equipment is the main content of the preparation for use.

By creating typical solutions for automated handling processes, the use preparation can be effectively supported in the application area.

It should not remain unmentioned that the automatic work piece handling by industrial robots can create hazardous situations. With the present state of safety engineering, these can be dictated only by reliable delimitation of the hazardous area, with absolute exclusion of unauthorized access by appropriate electrical interlocks. The qualifications of the employees accordingly must include intense instructions on work safety.

8348

CSO: 2302

GERMAN DEMOCRATIC REPUBLIC

INDUSTRIAL ROBOTS FOR FORMING MACHINERY DESCRIBED

East Berlin TECHNISCHE GEMEINSCHAFT in German Vol 29 No 12, Dec 81
(signed to press 30 Oct 81) pp 38-39

[Article by L. Morgenstern, engineer, Zwickau Research Center for Forming Processes:
"Industrial Robots for Sheet-Metal Forming Processes"]

[Text] With the development of mass production, automated production equipment arose in forming technology as a necessary precondition for effective production. In the area of small and medium series production, the handling of parts by human personnel frequently still predominates. It is necessary here, too, to deploy mechanization and automation technologies at individual presses and lines.

For years, the VEB Combine on Forming Technology "Herbert Warnke" Erfurt has been developing such equipment both for large presses (2, 5) and also for the small and medium presses that are widely distributed in the mvl (abbreviation unknown). For the latter, the Research Center for forming processes Zwickau (FZU) has frequently worked on multiply automated solutions as press complexes and has transferred these into industry.

Two construction sizes of plate feed-in devices with their own drive permit the subsequent automation of the most various press types (3). They are suitable for feeding in plates of different materials and shape from the stack. The construction size of transfer equipment makes possible the use of several processing stations on one press (6, 7). A modular organization here makes possible the adaptation of transfer equipment to various types of presses.

During the past years, a large number of solutions towards increased efficiency by means of handling equipment for use on presses have been generated in the mvl enterprises themselves as in-house designs. For this purpose, a responsible working team under the management of the FZU was formed, whose objective was the acquisition of solutions towards greater efficiency, which had broad follow-up application and organization of an exchange of experience up to the coordination of the in-house construction of efficiency means. These solutions towards increasing efficiency are popularized by means of a catalog which is currently being prepared by the FZU and which will be distributed beginning in January 1982.

The necessity of increasingly using industrial robots likewise manifests itself to the Combine for Forming Technology. Besides the plant application in in-house production, a design for increasing the flexibilities of forming and splitting

machines by means of industrial robots and manipulators was worked out. The development provided therein aimed towards a device technology which is more flexible and complex than the previous mechanization and automation technology and which thus shifts the economic use limit towards smaller lot sizes.

The first industrial robot, the MIRE 4/2, was developed in the FZU in only 18 months. In 1981, it was presented at the Spring Fair as a complex solution towards increasing efficiency in processing plates (4). In contrast to a simple blade feed-in, the IR MIRE 4/2 manipulates the plates according to selectable programs in the tool space in such a fashion that other work pieces can be fabricated from one plate. Up to now, manual handling with a low material utilization was necessary for this.

To use still more the available capacities of the machine parameters, peripheral equipment is also necessary. A plate in-feed constantly makes ready individual plates in constant output position, a roller ejector removes the residual grid from the working space, and a conveyor belt transports the cut-out work pieces from the eccentric press.

The drive of the MIRE 4/2 is pneumatic. All positioning is effected through programmable stops and is controlled through the new cassette variant PS 2000/1, in which programs are called merely by a selection switch in case of a conversion. With this complex of presses, up to 20 work pieces per minute are currently being produced from the residual metal sheets in the truck industry.

In the development of these industrial robots, several special features had to be noted for their deployment in presses. The switching times required at individual presses vary from 12 to 60 minutes and required cycle times of one to four seconds. Such times are not customary for the deployment of loading robots on metal-cutting machinery. The required positioning accuracy is high and, in the present case, is 0.1 mm. Working safety is also considerably improved, since the human personnel is completely separated from the hazardous area of the press (high working speed and high power of the ram of the shaping machine). However, conversion required the replacement of the tool (new stop position) as well as a new program sequence that is permanently associated with the particular working task. The tool change must here be speeded up; change of the program sequence by the operator is not required, however.

In evaluation of the experience gained with the MIRE 4/2, a further development for a press complex is in progress, which is convertible both for plate processing into several work pieces and for multistage processing of smaller plates. It therefore achieves a high degree of flexibility.

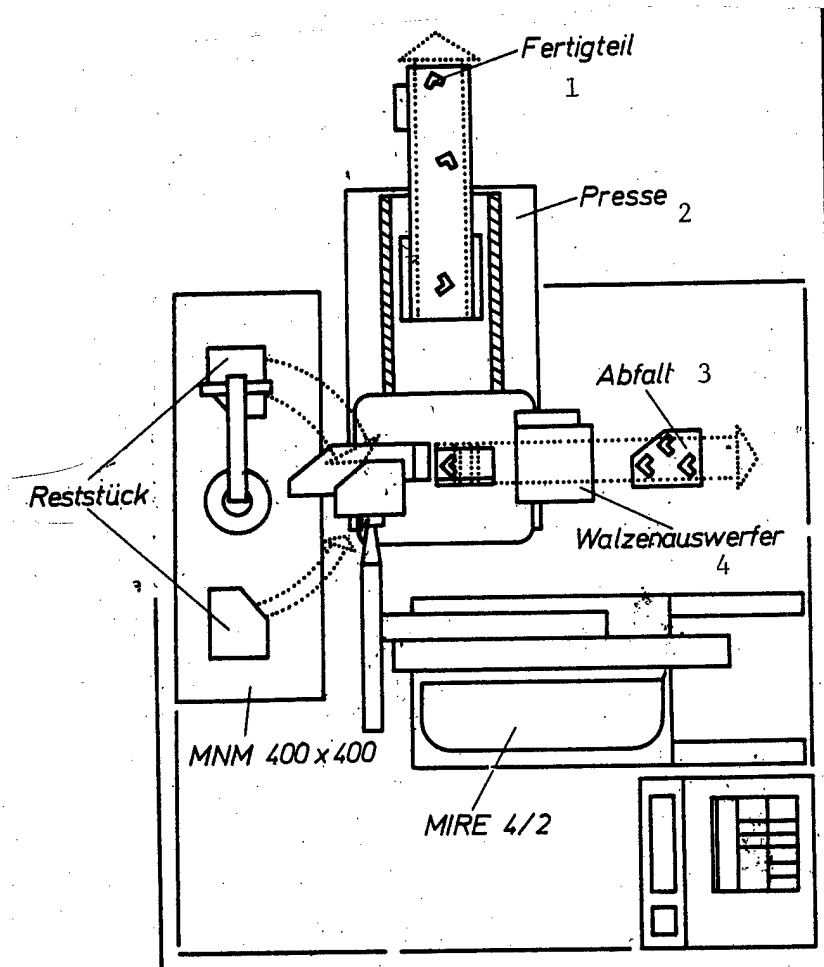

Press complex for the processing of plates

- 1 finished part
- 2 press
- 3 waste
- 4 roll ejector
- 5 residual piece

BIBLIOGRAPHY

- [1] Brochure - Conference on means for increasing efficiency in shaping and splitting technology. FZU Zwickau 1980.
- [2] Schmidt, G.: Automatic press complex with a simply acting two-stand press. PE 4-H-500/2800 x 1800 TS; UMFORMTECHNIK Zwickau (Shaping: Technology, Zwickau) 15 (1) 1-5, 1981.

- [3] Drechsel, M.: Construction series on plate feed-in devices for the automation of presses. UMFORMTECHNIK Zwickau (Shaping Technology, Zwickau) 16 (1) 24-26, 1981.
- [4] Brambauer/Voigt: Industrial robot MIRE 4/2 automates plate processing. UMFORMTECHNIK Zwickau (Shaping Technology, Zwickau) 15 (1) 27-32, 1981.
- [5] Schmidt, G.: Mechanized press complexes with mechanically acting single-axis two-stand press. PE 2-H-500/2800 x 1500 TS; UMFORMTECHNIK Zwickau (Shaping Technology, Zwickau) 14 (1) 1-5, 1980.
- [6] Braumbauer/Mädler: Hydraulic single-stand press PYE 100 SS automates with transfer equipment MTE 250/200. UMFORMTECHNIK Zwickau (Shaping Technology, Zwickau) 13 (1) 3-7, 1979.
- [7] Arnold/Drechsel: Construction series on transfer equipment for the automation of presses. UMFORMTECHNIK Zwickau (Shaping Technology, Zwickau) 12 (5) 41-46, 1978.

8348
CSO:2302

NEW TECHNOLOGY USED IN OIL, GAS EXTRACTION

Increasing Recovery Factor

Bucharest STIINTA SI TEHNICA in Romanian No 6, Jun 82 pp 15-16

[Article by Eng I. Sadeanu, Petroleum Ministry]

[Text] Assuring our country's energy independence, and in particular supplying the hydrocarbon resources for processing and chemification, imply the application of new methods and technologies for increasing the reserves that can be recovered from deposits, and for extracting oil from wells.

An increased volume of reserves is achieved primarily through the discovery of new deposits, as well as through greater recovery of oil from existing deposits. This important objective is stipulated in the Program for Increasing the Final Recovery Factor from Oil Deposits in Romania.

The final recovery factor is the ratio between the quantity of oil that can be extracted with known methods until the end of the exploitation (called the primary recoverable reserve), and the reserves that exist in the deposit (called the initial geologic reserves). The primary recoverable reserve represents the amount of oil that can be extracted using the deposit's own energy, meaning the natural formation dislocation rate toward the well head. The forces acting in this case, are: elastic expansion of rocks and fluids, pressurization of marginal water or gases from the gas dome, and outgasing of gases dissolved in the oil. In general, between 10 percent and a maximum of 40 percent of the initial geologic reserve can be extracted with the deposit's own energy, the remainder being restrained by capillary forces (surface adhesion at the area of contact between fluids and rock), which the deposit's own reduced energy cannot overcome.

In order to continue to increase the recovery factor, and therefore the volume of recoverable reserves, outside intervention with additional energy is necessary even before the deposit's own natural energy is exhausted. The resulting additional recoverable reserve is called the secondary reserve. Methods for increased recovery make use of water and gases as energy carriers (pressure, heat) or as carriers of chemical agents; introduced into injection wells, these can dislocate and push the residual oil from the rock's pores and microfissures toward reaction (production) wells.

Polymer flooding

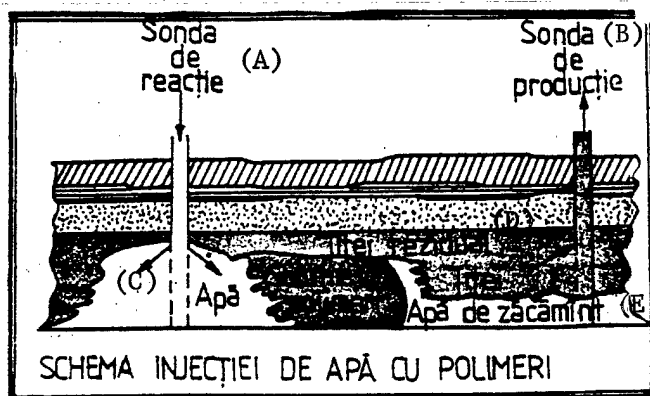

- Key:
- (A) Reaction well
 - (B) Production well
 - (C) Water
 - (D) Residual oil
 - (E) Deposit water

The most widely used fluid is the deposit water, which is available in large quantities, and which after purification and treatment, becomes compatible with the formation into which it is injected and the fluids which it dislocates. Well gases, burned gases, carbon dioxide, and inert gases are more expensive, and their sources are usually removed from the location at which they are used. Water or gas injection has been used in Romania for more than 40 years, either to maintain deposit pressures, or to dislocate oil by washing the rock's pores. In general, water is injected into wells located in the flooded or lower zone of a deposit; this is known as extra-contour injection, or in the production zone, as intra-contour injection. Gases are injected in the gas dome or intra-contour zone. These two categories of classic processes are called conventional methods.

In what follows, we will describe some new methods that are currently used to increase recovery. To begin with, there are the improved conventional methods, which include: water injection with modified drain lines (created by changing the position of injection and reaction wells, to wash the zones bypassed by the wash lines of the previous model), washing with water after gas injection (as secondary method to dislocate residual oil from the gas zone), and cyclic (pulsed) water injection at closed and fissured (carbonated) deposits. These methods are being applied at 53 percent of our country's deposits, with satisfactory results.

The truly new methods include:

Steam injection, which is applied in deposits of viscous oil, located as deep as 850 meters. The steam is supplied by high pressure generators (GIP), manufactured by CUG in Cluj-Napoca. About 800 t/cycle are injected into the well during cyclic injection, after which the well is closed; following cooling, the well is placed back in production, with an oil flow that is higher as a result of lower viscosity and thermal expansion.

Direct combustion

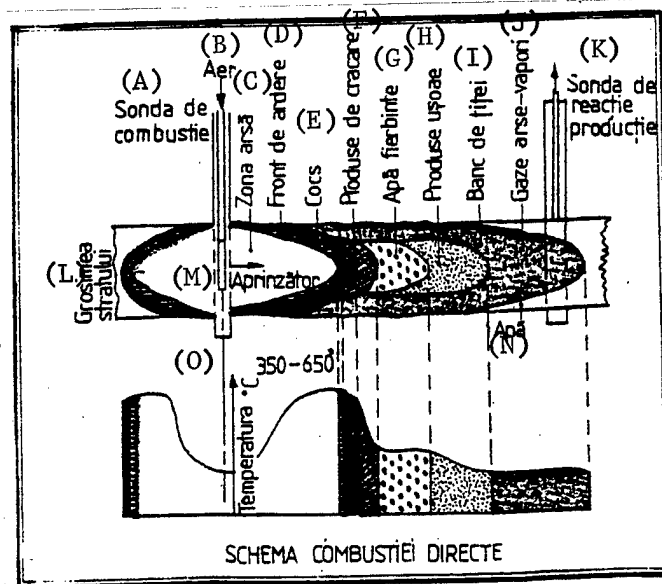

- Key:
- (A) Combustion well
 - (B) Air
 - (C) Burned zone
 - (D) Combustion front
 - (E) Coke
 - (F) Cracking products
 - (G) Hot water
 - (H) Light products
 - (I) Oil bank
 - (J) Burned gases, vapors
 - (K) Reaction production well
 - (L) Formation thickness
 - (M) Igniter
 - (N) Water
 - (O) Temperature 350-650

For continuous injection, successive hot zones are formed between injection and production wells, the oil flow being encouraged by lowered viscosity, vaporization, and dislocation by the hot water. Cyclic injection is being successfully used at Moreni, Videle, Suplacul de Barcau, and so on. A recovery factor of 30-50 percent can be achieved.

Underground combustion is achieved by igniting the oil in the deposit in several combustion wells, and slowly extending the combustion front toward reaction (production) wells by means of air injection through combustion wells.

Specialists at the Research and Design Institute for Oil and Gas Technology (ICPPG) at Cimpina, have developed original technologies for igniting the deposits. Combustion is initiated by means of several procedures, depending on the

characteristics of the deposit: igniting through air injection, with or without use of oxidizers (linseed oil introduced into the well); igniting through air injection, with electric heater introduced into the well, and with (or without) oxidizers; igniting with gas burner introduced into the well, and injection through two pipes (air and gas).

In the case of direct and dry combustion, the combustion front moves in the same direction as the injected air, while in the case of wet combustion, water slugs are introduced intermittently into the air stream to reduce it and increase the dislocation efficiency.

Several zones (vaporization, distillation, and cracking of the oil, as well as condensation) can be distinguished in the deposit combustion. The hot gases and the distillation products move, fluidize, and entrain the hot oil toward the reaction wells.

As secondary method, underground combustion can achieve recovery factors of 40-55 percent, and as tertiary method, factors of 50-65 percent.

At present, more than 10 deposits in Romania are at different phases of exploitation through underground combustion, with Suplacul de Barcau being the largest in the world.

Because of its performance, underground combustion is expected to be extended to other deposits in the future.

In the injection of polymer flooding, the addition of polyacrylamide to the injection water causes its mobility to be lower than the water or oil in the porous medium, and therefore to be less likely to channel into very permeable zones. This makes it possible to obtain a more uniform wash front, and therefore a recovery higher than that obtained with conventional water injection. The injection consists of a slug of polymer solution in a concentration of 300-1300 ppm, amounting to about 30 percent of the pore volume of the producing formation. The slug is then pushed with deposit water that has been purified to remove suspensions and such elements as Mg, Co, and Fe, which can block the formation.

This method can produce recovery factors of 35-55 percent, and is being tested at three deposits. It is used industrially at the Draganesti-Meotian deposit with favorable results.

Miscible displacement with micellar solutions is a chemical method in which a micellar solution (microemulsion) flows through the pores of the rock entraining (miscibly) both the oil and the water. Micellar solutions are composed of kerosene, petroleum sulfonates (surfactants), nonyl phenol, hexanol, alcohol (cosurfactant), and water. A slug of 5-10 percent of the porous volume is injected, followed by a slug of viscous water (with polymer), and the whole is then pushed with purified deposit water.

This method can achieve high final recovery factors of 55-66 percent, and its use in a large number of deposits is being planned.

Injection of carbon dioxide, which is a gas soluble in water, and especially in oil; its effect is to reduce the viscosity of the oil by 10 to 100 times, increase its volume, reduce water/oil/rock interface tension, and increase the permeability of the rock through its acid effect.

The basic materials for this method come from natural carbon dioxide sources, burned gases from thermal power plants, from fertilizer plants, or petrochemical plants. Although it is used at only a few deposits, this method is expected to be expanded in the future because sources of carbon dioxide are available, and because the possible factors that can be achieved are between 30 and 50 percent as secondary method, and between 50 and 65 percent as tertiary method.

Injection of alkaline (caustic) substances, and of surfactants or other surface active agents, is being studied and applied. The alkaline water introduced into deposits comes in contact with the organic acids of some oils (naphthenic) to form soaps which reduce the water/oil interface tension, and which change the wetting of the rock pores. This forms an emulsion which encloses the residual water and oil retained by capillary forces, their effect being partially similar to that of micellar solutions.

The method is promising, achieving recovery factors of 40-50 percent. Two tests have been started at the Baicoi well, one of which will be expanded industrially.

Oil exploitation with mining methods, using gravity draining through rising and dropping underground galleries and wells, is being tested at the Sarata-Monteoru mine, at a level lower than that exploited since 1925.

Geologic and hydrologic prospecting has been carried out at several old shallow deposits at Bustenari, Ochiuri, Moreni, Berca, and Moinesti, to analyze the possibilities for testing and applying oil mining methods safely and efficiently.

Based on these actions for intensifying the application and expansion of new methods for increased recovery, Romania is now among the leading countries which achieve a high level of oil recovery from deposits.

In the area of oil extraction, it is possible to use new methods and technologies designed for several areas. First among these is the need to carry out better openings of productive formations through perforation of casings with explosive or abrasive jets, which have a larger penetration radius behind the casing. Moreover, deterioration of the filter zone around the well will be avoided through the use of drilling and wash fluids without solid suspensions but with the addition of various chemical agents.

The new installations of rotopercussive drilling will avoid the penetration of drilling fluids into low pressure productive formations through the use of percussive drilling.

Using various treatments with complex acid solutions (domestic ACOR-type surfactant substances, micellar solutions, selective or multiple acid fissuring), oil flow in well holes will be increased through reconstruction of the permeability damaged during exploration. This type of operation is being conducted at present with good results.

To combat sand floods in well formations, the latter will be consolidated with sand that has been moistened with resins or plastics, and various types of filters with electrically etched slots will be introduced in wells. One technology successfully used to prevent sand flows into well holes at depths of up to 1200 m, is short term combustion. Similarly, injection of hot air into formations consolidates the oil-bearing sand into coke; when the well is replaced in production, the oil flow is increased and sand flooding is eliminated. These technologies have increased the duration of operation of depth pumps, reduced the number and duration of interventions in wells, and implicitly, raised exploitation and production coefficients.

Displacement of fluids in pipes with nitrogen, and the high-pressure injection of this inert gas into formations, have also reduced the duration of tests and hastened the placement in production. At the same time, new equipment and devices will be used to improve extraction systems and technologies. Some of these are: starting valves for wells exploited by artificial blowout, which save energy and compressed gases; large downwell hydraulic and centrifugal pumps for the exploitation of intermediate and deep wells, which achieve higher outputs and lower energy consumptions compared to rod pumps; centralized remote control installations for deep pumping wells, which allow simultaneous constant control of hundreds of wells. In this way, any defect or interruption in the operation of downwell or surface equipment is immediately detected and efficiently corrected.

By increasing the utilization of well gases in modern ethane removal and desulfuration installations, the production of liquefied gases has been substantially increased, as has been the recovery of large amounts of sulfur from well gases that contain hydrogen sulfide. This method will be widely expanded.

Well Drilling

Bucharest STIINTA SI TEHNICA in Romanian No 6, Jun 82 p 17

[Article by Eng Ion Dobre, Cimpina Research and Design Institute for Oil and Gas Technology]

[Text] The spectacular increase in the consumption of energy, and of hydrocarbons in particular, has led to the steady development and improvement of well drilling technology. New technologies have thus been created, necessary for exploiting deposits located at increasingly greater depths, in arctic regions, underwater, under cities, or in deserts.

The first wells were drilled in 1859, using a percussion process, followed 40 years later by the rotary drilling process on which today's technology is still based. During this period, our country's petroleum industry has steadily developed with the creation of new types of drilling installations, steels for manufacturing tubular equipment, devices and instruments necessary for geophysical investigations, new types of drilling fluids, and so on.

Drill bits have undergone a strong development, with the adoption of sealed or slide bearings, of milled teeth, and of sintered carbide insert bits. As a result of these developments, the drillings depths achieved and the lifetime of drills in holes have steadily increased. The appearance of diamond drills and core bits has made it possible to reduce the time needed to drill wells.

Drilling methods have been steadily improved. Jet drilling is thus no longer a novelty, being commonly used by every group at every well. Today, better correlations are being sought between the mechanical energy and the hydraulic energy transmitted to the drill, in order to achieve rock dislocation in an optimum domain.

To prevent the well hole's natural tendency to deviate from the vertical (a situation encountered in Romania in Paleocene flysch structures in Neocene zones) technologic steps have been taken that are now under investigation.

A first and most rational measure, is to select the surface location of wells so that the use of an optimum, unrestricted drilling program will cause the well to follow a natural deviation tendency, and to meet the production formation at the planned bottom location.

Other procedures require reduced weight on the bit (an undesirable procedure, since it reduces the advance rate and increases drilling costs), increased drill stem diameters above the bit ("pendulum" effect), and stabilization of drill stems.

In the area of downwell motors, large scale experiments have recently been conducted at low-depth wells (1200 m) with a totally new and revolutionary concept, drilling with a flexible FLEXOFORAJ rig. The drill pipe rig consisting of steel pipes is replaced with a flexible armored rubber hose whose walls contain electric conductors that transmit to the bottom electricity to power a downwell motor. The same flexible tube transmits to the well bottom hydraulic power from the drilling fluid, to drive a downwell hydraulic motor (turbine or Dynadrill volumetric motor).

In order to reduce to a minimum the negative effects of the drilling fluid on the advance rate, the modern trend is to use fluids with the lowest density compatible with pressures in the encountered formations, that is, to apply the technology of "equilibrium" drilling. In order to safely apply the equilibrium drilling technology, the pressure in the traversed formations must be known in advance. A number of methods are currently available to determine the pressures in rock pores, starting from data obtained from neighboring wells, monitoring various parameters in wells that are being drilled, and performing geophysical measurements. Equilibrium drilling has the advantage that it does not create differential pressures within formations opened during the drilling, eliminates the danger of jammed drilling rigs, eases the removal of waste from the bottom, and increases the rate of drill advance.

In drilling some wells, deliberate deviations of the well hole are created to avoid crossing a water flooded zone, to drill bunched (multiple) wells from a fixed location on the ground or on sea platforms, to drill wells whose bottoms are in inaccessible areas (under cities or lakes), and to drill recovery wells. In these situations, the use of computers to process and interpret drilling data makes it

possible to establish optimum mechanical and hydraulic parameters for drilling rates, assemble rigid rigs, plan the trajectory of the well hole as a function of specific geophysical conditions, establish cementing programs, and correlate drilling fluid density with pressure gradients and fissuring in geological formations.

One of the difficult situations that can be encountered during the drilling of a well, is the loss of flow as a result of crossing formations with high permeability and with low pore pressures. The consequences of such a situation are very serious (blow-outs, jamming of drilling rigs, collapse of well walls), leading to considerable financial losses. Various procedures are used to correct such situations, such as packing fissures with packing materials added to drilling fluids, drilling with aerated fluids, foam drilling, drilling with air-lift reverse flow, and so on. Reverse flow drilling has also yielded good results in the drilling of old production spaces, injection wells, or even production wells with low formation pressures.

The fabrication of well-mouth seals and blow-out protectors has made it possible to undertake drilling with air or gases in recent years. This drilling is possible in hard rocks, in water-free formations, in porous and spongy rocks, and in oil and gas formations exploited at old sites.

Transmission of the mechanical energy necessary to dislocate rocks at the well bottom, directly to the drill through a mechanical shaft (drilling rig), through the intermediary of a hydraulic fluid (drilling fluid), is a matter that is still being debated throughout the world. Low speed drilling turbines have recently been designed, that have been successfully tested down to 3900 m with roller drills, and to 6468 m with diamond drills. The use of downwell motors offers unquestionable advantages for directed drilling, to deviate wells in the direction desired, an area in which downwell motors are currently finding an extensive application.

Special drilling fluids have been formulated to increase the hydraulic power delivered to the drill; these are inhibitive drilling fluids, fluids based on petroleum products, inverse emulsion fluids, non-dispersed fluids, sea water fluids, and so on. Equipment has been built to clean out waste and other materials entrained in fluids during drilling (modern sieves, sand removers, desilting devices, degasers, and so on).

The instability of well walls is no longer being combatted through uncontrolled introduction of heavier weight fluids, but rather by correlating minimum and maximum density with the pressure and fissuring gradients of the formations encountered.

The need to meet the consumption of oil and gases has launched intensive prospecting, extending to lakes, seas, and oceans. More than 100 countries are currently carrying out offshore drilling.

The special aspect of offshore drilling is not the drilling technology, but the manner of emplacing the drilling installation. These installations are composed of a platform and of the drilling installation itself. The platforms can be fixed or mobile (self-erecting, submersible, semi-submersible, drilling vessel, and so on).

Romania has designed, built, and launched the offshore drilling platform Gloria, which is self-erecting, stands on four legs, and can drill down to 6000 m in 90 meter-deep water.

A great deal of interest currently exists in creating devices and procedures for measuring drilling data during actual drilling (well inclination and azimuth, position of deviation device, and so on), using systems for telemetric data transmission, with or without cable, between bottom and surface equipment. Some electronic measurement and automatic control systems have reached a high degree of sophistication. Drilling data from the well is transformed into digital values printed on punched tape or plots. This data is transmitted to a computer, stored in its memory, and processed. As well depths increase, the cost per drilled meter also increases; the cost for wells beyond 4500 m is double that of wells of average depth, and for offshore wells is 2-4 times higher than that of dry land wells. These high costs are sound reasons for seeking new technologies to increase drilling speed, and for manufacturing new rock removal tools that can operate at the bottom of wells for long periods of time.

All these improvements in well drilling technology are part of the current concern for passing through this period of world energy crisis.

Automation Program

Bucharest STIINTA SI TEHNICA in Romanian No 6, Jun 82 p 18

[Article by Eng Valeriu Patrascu, Ministry of Petroleum]

[Text] For the drilling and extraction of oil and gases, the 1981-1985 five-year plan represents a true technical revolution in terms of specific installations for petroleum activities. The development of the machine building industry, the electrical industry, and especially the electronics industry, in our country, has made it possible to build drilling and extraction installations according to modern technology design and construction standards.

Drilling installations are driven by direct current motors supplied from the alternating current network through high-power thyristor rectifiers (700 A). The 1 Mai enterprise in Ploesti is presently mass producing the 200 t F 200 EC drilling installation, with four 850 kW direct current motors that drive the winch, the rotary rig, and two 2PN-700 drilling fluid pumps.

During 1982, the same enterprise will start mass producing the F 125 EC and F 320 EC drilling installations, while the Tirgoviste Enterprise for Petroleum Equipment will produce the F 100 EC, thus completing an entire line of direct current electric motor drilling installations.

These installations can be connected to 20 kV lines through 20/0.660 kV transformers, or to local micro-power plants composed of three diesel-electric generators with 3000 hp, 12 cylinder engines manufactured by the Resita Machine Building Enterprise, and with 2500 kVA, 660 V alternating current generators made by Electroputere in Craiova.

Electric drilling installations are equipped with safety devices which make it possible to raise the rig when electric power fails as a result of system problems.

The advantages of electric installations in Romania, compared to diesel-hydraulic or diesel-electric drilling, can be found in the following indicators:

Conventional fuel consumption is reduced by an average of 19 percent, and can reach 30 percent in installations that drill deeper than 3000 m;

Drilling time per well is reduced by about 15 percent because the electric motors are more rugged than thermal engines;

Spare parts costs for electric motors and equipment are insignificant compared to those for engines, conventional hydraulic equipment, and mechanical transmissions;

Electrically operated drilling installations allow better monitoring, control, and automation than thermal engine installations;

The density of intermediate voltage electric networks in our country makes it possible to connect 70 percent of the Petroleum Ministry drilling installations to the national network.

Taking into consideration the definite advantages of electric drilling over thermal engines, as well as the directions in which the national energy base will develop during the 1982-1990 period--which establish coal and hydraulic energy as the major sources for electric power--the Petroleum Ministry has established a program for endowment with electric drilling installations, which by 1985 will represent 70 percent of all drilling installations.

The continued development of technology demands that new approaches be used, which will improve the specifications of these installations. The technical directorate of the ministry, together with the Center for Scientific Research and Technical Engineering at the Electroputere enterprise in Craiova, is studying the construction during the 1985-1990 period, of drilling installations operated by asynchronous electric motors, with frequency converter speed controls, thus making it possible to use the simplest and most rugged type of electric motor.

In the oil and gas extraction activity, the concerns of specialists in the Petroleum Ministry for modernizing installations are:

Expanded use of automated monitoring systems for oil and gas extraction wells;

Automation of technical processes for collecting, separating, and processing stored crude oil, as well as a closed system for its transportation to avoid light-fraction losses.

Automatic monitoring of oil extraction wells provides dispatchers with a cathode-ray tube display of well dynamograms and electrograms, and thus makes it possible to know exactly at all times, the status of oil extraction from the well. In cases of electric power interruption, each well can be restarted from the dispatcher station upon resumption of the power. The introduction of load transducers makes it possible to automatically pump and pause as needed.

For 1982-1985, the program provides for the central automation of 5000 oil extraction wells, and 1000 gas extraction ones.

This vast program is carried out with the collaboration of research and design institutes such as the Bucharest Institute for Planning, Automation, Computer Technology, and Telecommunications, the Bucharest Institute for Research and Technical Engineering in Electronics, the Cimpina ICPPG, as well as construction and installation industrial enterprises specializing in this type of operations (Cimpina Enterprise for Electrical Equipment Repair, and Energopetrol in Cimpina). The transportation of crude oil from the well to refineries in closed systems, eliminates the loss of the most valuable light fractions. The process involves the achievement of technologic procedures specific for each location, and the building of installations imposes the need for high technology equipment and instruments.

At present, the Cimpina ICPPG is experimenting at the Boldesti extraction well with equipment and instruments manufactured in Romania, that during the 1983-1985 period are expected to be widely used at all oil and gas extraction wells. The construction of these installations will also automate the injection of water in deposits, reducing the transportation of this water and of course, the power consumption for its pumping.

This presentation of major actions for modernizing technical installations for oil and gas drilling and extraction demonstrates the intrinsic connection that exists among the oil industry, the machine building industry, electrical technology, and electronics, without which this qualitative leap could not have been possible.

11,023
CSO: 2702/16

END