

TECHNICAL REPORT RD-MG-98-33

**A METHOD FOR DETERMINATION OF TARGET ASPECT
ANGLE WITH RESPECT TO AN UNLEVELED RADAR**

**David C. Abell
Willie D. Caraway III
Missile Guidance Directorate
Missile Research, Development, and Engineering Center**

19980910 107

July 1998



U.S. ARMY AVIATION AND MISSILE COMMAND
Redstone Arsenal, Alabama 35898-5000

Approved for public release; distribution is unlimited.

DTIC QUALITY INSPECTED 1

DESTRUCTION NOTICE

FOR CLASSIFIED DOCUMENTS, FOLLOW THE PROCEDURES IN DoD 5200.22-M, INDUSTRIAL SECURITY MANUAL, SECTION II-19 OR DoD 5200.1-R, INFORMATION SECURITY PROGRAM REGULATION, CHAPTER IX. FOR UNCLASSIFIED, LIMITED DOCUMENTS, DESTROY BY ANY METHOD THAT WILL PREVENT DISCLOSURE OF CONTENTS OR RECONSTRUCTION OF THE DOCUMENT.

DISCLAIMER

THE FINDINGS IN THIS REPORT ARE NOT TO BE CONSTRUED AS AN OFFICIAL DEPARTMENT OF THE ARMY POSITION UNLESS SO DESIGNATED BY OTHER AUTHORIZED DOCUMENTS.

TRADE NAMES

USE OF TRADE NAMES OR MANUFACTURERS IN THIS REPORT DOES NOT CONSTITUTE AN OFFICIAL ENDORSEMENT OR APPROVAL OF THE USE OF SUCH COMMERCIAL HARDWARE OR SOFTWARE.

REPORT DOCUMENTATION PAGE

Form Approved
OMB No. 0704-0188

Public reporting burden for this collection of information is estimated to average 1 hour per response, including the time for reviewing instructions, searching existing data sources, gathering and maintaining the data needed, and completing and reviewing the collection of information. Send comments regarding this burden estimate or any other aspect of this collection of information, including suggestions for reducing this burden, to Washington Headquarters Services, Director for Information Operations and Reports, 1215 Jefferson Davis Highway, Suite 1204, Arlington, VA 22202-4302, and to the Office of Management and Budget, Paperwork Reduction Project (0704-0188), Washington, DC 20503.

1. AGENCY USE ONLY (Leave Blank)		2. REPORT DATE July 1998	3. REPORT TYPE AND DATES COVERED Final
4. TITLE AND SUBTITLE A Method for Determination of Target Aspect - Angle with Respect to an Unleveled Radar			5. FUNDING NUMBERS
6. AUTHOR(S) David C. Abell Willie D. Caraway			
7. PERFORMING ORGANIZATION NAME(S) AND ADDRESS(ES) Missile Guidance Directorate Missile Research, Development, and Engineering Center			8. PERFORMING ORGANIZATION REPORT NUMBR TR-RD-MG-98-33
9. SPONSORING/MONITORING AGENCY NAME(S) AND ADDRESS(ES) Commander, U. S. Army Aviation and Missile Command Missile Research, Development, and Engineering Center ATTN: AMSAM-RD-MG Redstone Arsenal, AL 35898			10. SPONSORING/MONITORING AGENCY REPORT NUMBER
11. SUPPLEMENTARY NOTES			
12a. DISTRIBUTION/AVAILABILITY STATEMENT Approved for public release; distribution is unlimited.			12b. DISTRIBUTION CODE A
13. ABSTRACT (Maximum 200) This document is a continuation of work derived in "A Method for the Determination of Target Aspect Angle with Respect to a Radar" by Caraway and Abell [1]. The original paper derived the target aspect angle assuming that the radar would be emplaced level with respect to gravity. With the need for rapid and flexible emplacement, some radars may be designed to allow for unlevel operation. Aspect angle determination is essential in many forms of Noncooperative Target Identification (NCTI). This document presents a rigorous development of the mathematics for solving for target aspect angle given target and radar position and attitude. A method for aspect angle estimation given target track data will also be presented.			
14. SUBJECT TERMS Noncooperative Target Identification (NCTI)			15. NUMBER OF PAGES 15
			16. PRICE CODE
17. SECURITY CLASSIFICATION OF REPORT Unclassified	18. SECURITY CLASSIFICATION OF THIS PAGE Unclassified	19. SECURITY CLASSIFICATION OF THIS ABSTRACT Unclassified	20. LIMITATION OF ABSTRACT SAR

TABLE OF CONTENTS

	Page
I. DEFINITIONS	3
II. ASPECT ANGLE ESMUTION USING THE RADAR TRACK.....	4
III. CLOSED FORM SOLUTION.....	7
BIBLIOGRAPHY.....	9

I. DEFINITIONS

This document is a supplement to "A Method for Determination of Target Aspect Angle with Respect to a Radar" by Caraway and Abell [1]. The aspect angles or radar look angles are given in Equations (1) and (2) (Fig. 1). As shown in Figure 1, the aspect angles are defined by the vector from the aircraft to the radar and are defined in the coordinate system relative to the aircraft. This means that aspect angle is only affected by the position of the radar and is independent of the radar's orientation. An exception is when a linearly polarized radar beam is used. This case requires a third equation for the polarization angle to define the rotation of the aircraft coordinate system with respect to polarization of the radar beam. This is not applicable for circularly polarized beams.

$$\theta = \cos^{-1} \left(\frac{V'_{ARx}}{\sqrt{(V'_{ARx})^2 + (V'_{ARy})^2}} \right) \quad (1)$$

$$\phi = \tan^{-1} \left(\frac{V'_{ARz}}{\sqrt{(V'_{ARx})^2 + (V'_{ARy})^2}} \right) \quad (2)$$

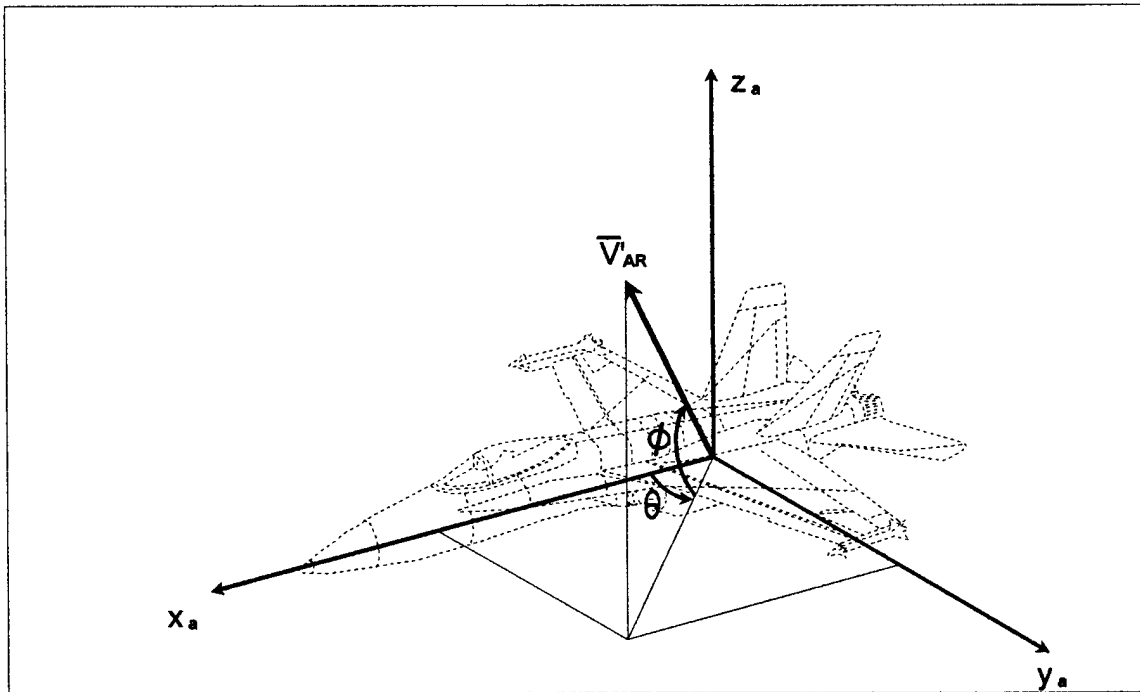

Figure 1. Aircraft Aspect Angles

Polarization angle will not be addressed in this report. When radar measurements are combined with aircraft roll, pitch, and heading in calculating the exact solution of the aspect angles, the orientation of the radar must be taken into account. This is due to the fact that radar measurements are taken with respect to the orientation of the radar while aircraft orientation angles are defined with respect to the plane normal to gravity for roll and pitch and with respect to true north for heading.

II. ASPECT ANGLE ESTIMATION USING THE RADAR TRACK

One way that a tracking radar can estimate the aspect angles is by assuming that the orientation of the aircraft is determined solely by the velocity vector of the aircraft relative to the radar. The pitch and heading can be described by this vector, and since the vector is measured by the radar, these terms are in the plane of the radar. Since the roll of an aircraft is generally a rotation along the axis of flight, it is not measured by this vector. We can assume that for most flight scenarios, the roll of the aircraft is zero with respect to the plane of the horizon for straight and level flight of an aircraft. This induces error with an unlevelled radar due to an inconsistent reference plane. This yields a maximum error (in the elevation aspect angle equal to the maximum angle that the platform is off level) only when the aircraft is perpendicular to the axis of tilt of the radar and the aircraft is traveling tangential to the radar scan. The error goes to zero on inbound and outbound tracks, and on all tracks when the aircraft is along the axis of tilt of the radar. With an aircraft tilt of 5 degrees, the roll estimation error relative to true zero roll is small in most flight profiles. Using these estimations, the aspect angles are shown in Figures 2 and 3.

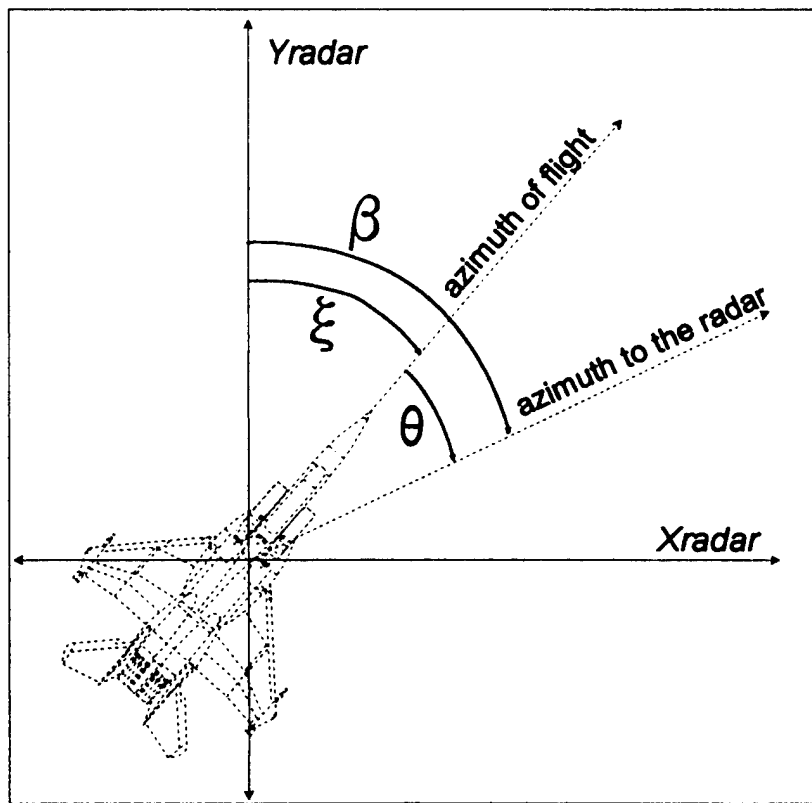

Figure 2. Simplified Estimate of θ

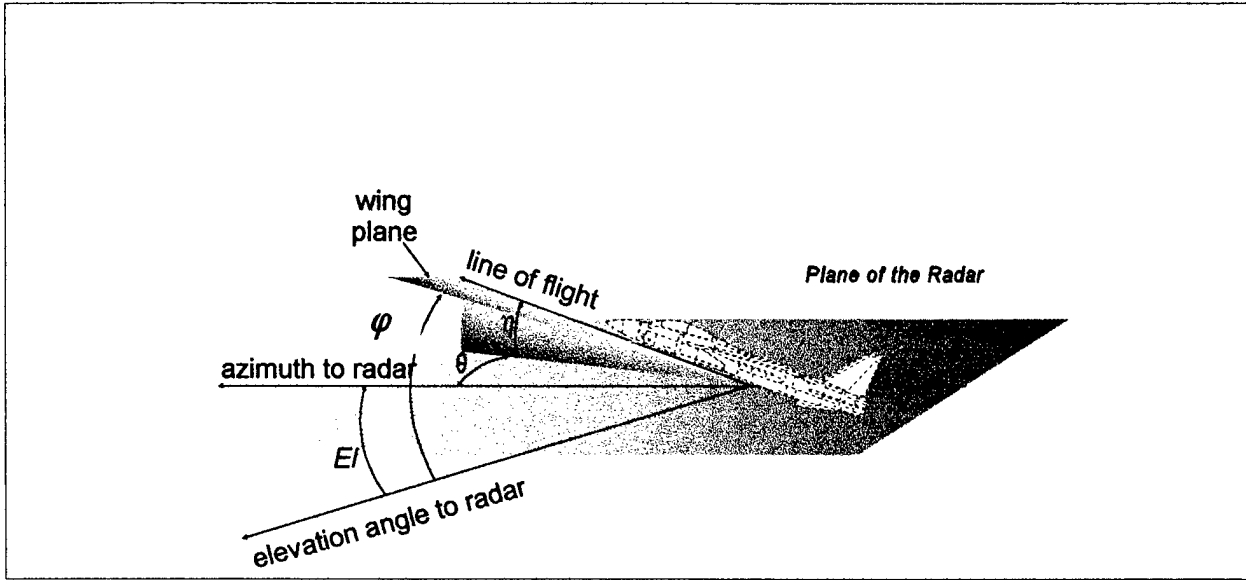

Figure 3. Simplified Estimate of ϕ

To determine the direction of motion of the aircraft, linear travel from the previous target point to the current (or predicted) target point can be used. A predicted or future point is used to take advantage of the radar tracker and spreading the points out in position results in a smoothing effect of radar measurement error. The measurements from the radar are given in range, azimuth, and elevation relative to the radar. These can be converted to an x_r, y_r, z_r coordinate system using

$$x_r = Rng \sin(Az) \cos(El) \quad (3)$$

$$y_r = Rng \cos(Az) \cos(El) \quad (4)$$

$$z_r = Rng \sin(El). \quad (5)$$

The change in $x_r, y_r,$ and $z_r,$ from a previous position to a predicted or future position, is given by:

$$\Delta x = x_f - x_p; \Delta y = y_f - y_p; \Delta z = z_f - z_p. \quad (6)$$

From this, the pitch angle relative to the plane of the radar can be calculated as:

$$\xi = \tan^{-1}(\Delta y_r / \Delta x_r) \quad (7)$$

and the heading angle relative to the radar can be calculated as:

$$\eta = \tan^{-1}(\Delta z_r / \sqrt{(\Delta x_r)^2 + (\Delta y_r)^2}). \quad (8)$$

Now using Figures 2 and 3, the aspect angles can be given by:

$$\theta = \beta - \xi \quad (9)$$

$$\phi = -1(\eta \cos(\theta) + E1) \quad (10)$$

where: β (Fig. 2) = $-1 * Az$, which is the back azimuth from the aircraft to the radar.

This estimation of aspect angle contains assumptions about the aircraft's roll, pitch, and heading. The roll assumption has already been addressed. Pitch is assumed to be along the direction of flight. This ignores the angle of attack which is the amount of pitch up that the aircraft requires to maintain flight. This has been demonstrated to range from 2 to 5 degrees on tests on two fighter aircraft. Heading is assumed to be along the direction of flight. This ignores yaw which can be introduced in this angle due to wind. This is referred to as the crab angle. Better estimations of roll, pitch, and heading can be made; however, these estimations will be relative to the plane of the horizon at the aircraft. An exact solution to the aspect angles of the aircraft relative to an unlevelled radar is required to include these estimations.

III. CLOSED FORM SOLUTION

The equation for the coordinate transformation from the aircraft coordinate system to the radar's is given in Reference 1 as:

$$\begin{bmatrix} x_a \\ y_a \\ z_a \end{bmatrix} = \mathbf{J}^{-1} \begin{bmatrix} x \\ y \\ z \end{bmatrix} \quad (11)$$

where $[x \ y \ z]$ is the coordinate system at the radar for a level, north-aligned radar. The inverse transformation matrix, \mathbf{J}^{-1} , was derived in the original paper to be:

$$\mathbf{J}^{-1} = \begin{bmatrix} \cos(\xi')\cos(\eta) & -\sin(\xi')\cos(\eta) & \sin(\eta) \\ \cos(\xi')\sin(\eta)\sin(\zeta) + \sin(\xi')\cos(\zeta) & -\sin(\xi')\sin(\eta)\sin(\zeta) + \cos(\xi')\cos(\zeta) & -\cos(\eta)\sin(\zeta) \\ -\cos(\xi')\sin(\eta)\cos(\zeta) + \sin(\xi')\sin(\zeta) & \sin(\xi')\sin(\eta)\cos(\zeta) + \cos(\xi')\sin(\zeta) & \cos(\eta)\cos(\zeta) \end{bmatrix} \quad (12)$$

where ξ is the aircraft heading angle and $\xi' = \xi - 90$ degrees. This is due to the fact that the aircraft reference system has the x-axis to the north while the radar system has the x-axis to the east. η is the pitch angle, and ζ is the aircraft roll angle. When the radar is unlevelled, a stabilization matrix must be applied to transform the $[x_u \ y_u \ z_u]$ (unlevelled coordinate system) into $[x \ y \ z]$ (the levelled coordinate system).

$$\begin{bmatrix} x \\ y \\ z \end{bmatrix} = \mathbf{S} \begin{bmatrix} x_u \\ y_u \\ z_u \end{bmatrix} \quad (13)$$

When Equation (13) is substituted into Equation (11), the transformation from the unlevelled radar coordinate system to the aircraft coordinate system becomes:

$$\begin{bmatrix} x_a \\ y_a \\ z_a \end{bmatrix} = \mathbf{J}^{-1} * \mathbf{S} \begin{bmatrix} x_u \\ y_u \\ z_u \end{bmatrix} \quad (14)$$

The next step is to derive the stabilization matrix S . This now becomes a three axis rigid body rotation. Since each rotation is linear, the rotations are separable. The three angles are the radar's north offset (α), the radar's pitch angle (β), and the radar's roll angle (γ). The first transform is due to α and is a rotation about the z-axis and is given by:

$$\begin{bmatrix} x \\ y \\ z \end{bmatrix} = \begin{bmatrix} \cos(\alpha) & \sin(\alpha) & 0 \\ -\sin(\alpha) & \cos(\alpha) & 0 \\ 0 & 0 & 1 \end{bmatrix} \begin{bmatrix} x' \\ y' \\ z' \end{bmatrix} \quad (15)$$

The second transform is due to the pitch angle, β , and is a rotation about they y'-axis and is given by:

$$\begin{bmatrix} x' \\ y' \\ z' \end{bmatrix} = \begin{bmatrix} \cos(\beta) & 0 & -\sin(\beta) \\ 0 & 1 & 0 \\ \sin(\beta) & 0 & \cos(\beta) \end{bmatrix} \begin{bmatrix} x'' \\ y'' \\ z'' \end{bmatrix} \quad (16)$$

The final transform is due to the roll angle, γ , of the radar and is a rotation about the x''-axis and given by:

$$\begin{bmatrix} x'' \\ y'' \\ z'' \end{bmatrix} = \begin{bmatrix} 1 & 0 & 0 \\ 0 & \cos(\gamma) & \sin(\gamma) \\ 0 & -\sin(\gamma) & \cos(\gamma) \end{bmatrix} \begin{bmatrix} x_u \\ y_u \\ z_u \end{bmatrix} \quad (17)$$

Equations (16) and (17) substituted into Equation (15) yields:

$$\begin{bmatrix} x \\ y \\ z \end{bmatrix} = \begin{bmatrix} \cos(\alpha)\cos(\beta) & \sin(\alpha)\cos(\gamma) + \cos(\alpha)\sin(\beta)\sin(\gamma) & \sin(\alpha)\sin(\gamma) - \cos(\alpha)\sin(\beta)\cos(\gamma) \\ -\sin(\alpha)\cos(\beta) & \cos(\alpha)\cos(\gamma) - \sin(\alpha)\sin(\beta)\sin(\gamma) & \cos(\alpha)\sin(\gamma) + \sin(\alpha)\sin(\beta)\cos(\gamma) \\ \sin(\beta) & -\cos(\beta)\sin(\gamma) & \cos(\beta)\cos(\gamma) \end{bmatrix} \begin{bmatrix} x_u \\ y_u \\ z_u \end{bmatrix} \quad (18)$$

Now substituting Equations (12) and (18) into Equation (14) and multiplying will give the complete transformation from the unleveled radar to the coordinate system of the aircraft. This is done in the following equation with S and C used as shorthand for sin()and cos().

$$\begin{bmatrix} x_a \\ y_a \\ z_a \end{bmatrix} = \begin{bmatrix} C\xi'C\eta C\alpha C\beta + S\xi'C\eta S\alpha S\beta + S\eta S\beta \\ (C\xi'S\eta S\zeta + S\xi'C\zeta)C\alpha C\beta - (S\xi'S\eta S\zeta - C\xi'C\zeta)S\alpha C\beta - C\eta S\zeta S\beta \\ (S\xi'S\zeta - C\xi'S\eta C\zeta)C\alpha C\beta - (S\xi'S\eta C\zeta + C\xi'S\zeta)S\alpha C\beta + C\eta C\zeta S\beta \\ (S\alpha C\gamma + C\alpha S\beta S\gamma)C\xi'C\eta + (S\alpha S\beta S\gamma - C\alpha C\gamma)S\xi'C\eta - C\beta S\gamma S\eta \\ (C\xi'S\eta S\zeta + S\xi'C\zeta)(S\alpha C\gamma + C\alpha S\beta S\gamma) + (C\xi'C\zeta - S\xi'S\eta S\zeta)(C\alpha C\gamma - S\alpha S\beta S\gamma) + C\eta S\zeta C\beta S\gamma \\ (S\xi'S\zeta - C\xi'S\eta C\zeta)(S\alpha C\gamma + C\alpha S\beta S\gamma) + (S\xi'S\eta C\zeta + C\xi'S\zeta)(C\alpha C\gamma - S\alpha S\beta S\gamma) - C\eta C\zeta C\beta S\gamma \\ (S\alpha S\gamma - C\alpha S\beta C\gamma)C\xi'C\eta - (C\alpha S\gamma + S\alpha S\beta C\gamma)S\xi'C\eta + C\beta C\gamma S\eta \\ (C\xi'S\eta S\zeta + S\xi'C\zeta)(S\alpha S\gamma - C\alpha S\beta C\gamma) + (C\xi'C\zeta - S\xi'S\eta S\zeta)(C\alpha S\gamma + S\alpha S\beta C\gamma) - C\eta S\zeta C\beta C\gamma \\ (S\xi'S\zeta - C\xi'S\eta C\zeta)(S\alpha S\gamma - C\alpha S\beta C\gamma) + (S\xi'S\eta C\zeta + C\xi'S\zeta)(C\alpha S\gamma + S\alpha S\beta C\gamma) + C\eta C\zeta C\beta C\gamma \end{bmatrix} \begin{bmatrix} x_u \\ y_u \\ z_u \end{bmatrix} \quad (19)$$

Now using Equations (3) through (5) a pointing vector from the radar's location to the aircraft \hat{V}_{RA} , can be defined as:

$$\hat{V}_{RA} = \sin(Az)\cos(EI)\hat{x} + \cos(Az)\cos(EI)\hat{y} + \sin(EI)\hat{z}. \quad (20)$$

Noting that the transform can be written as:

$$\hat{V}_{AR} = \mathbf{J}^{-1} * \mathbf{S}(-\hat{V}_{RA}). \quad (21)$$

And substituting into Equation (20) and expanding:

$$\begin{aligned} V_{AR_x} = & -\sin(Az)\cos(EI)(C\xi'C\eta C\alpha C\beta + S\xi'C\eta S\alpha S\beta + S\eta S\beta) - \\ & \cos(Az)\cos(EI)((S\alpha C\gamma + C\alpha S\beta S\gamma)C\xi'C\eta + (S\alpha S\beta S\gamma - C\alpha C\gamma)S\xi'C\eta - C\beta S\gamma S\eta) - \\ & \sin(EI)(S\alpha S\gamma - C\alpha S\beta C\gamma)C\xi'C\eta - (C\alpha S\gamma + S\alpha S\beta C\gamma)S\xi'C\eta + C\beta C\gamma S\eta \end{aligned} \quad (22a)$$

$$\begin{aligned} V_{AR_y} = & -\sin(Az)\cos(EI)((C\xi'S\eta S\zeta + S\xi'C\zeta)C\alpha C\beta - (S\xi'S\eta S\zeta - C\xi'C\zeta)S\alpha C\beta - C\eta S\zeta S\beta) - \\ & \cos(Az)\cos(EI)((C\xi'S\eta S\zeta + S\xi'C\zeta)(S\alpha C\gamma + C\alpha S\beta S\gamma) + C\xi'C\zeta - S\xi'S\eta S\zeta)(C\alpha C\gamma - S\alpha S\beta S\gamma) + C\eta S\zeta C\beta S\gamma) - \\ & \sin(EI)((C\xi'S\eta S\zeta + S\xi'C\zeta)(S\alpha S\gamma - C\alpha S\beta C\gamma) + (C\xi'C\zeta - S\xi'S\eta S\zeta)(C\alpha S\gamma + S\alpha S\beta C\gamma) - C\eta S\zeta C\beta C\gamma) \end{aligned} \quad (22b)$$

$$\begin{aligned} V_{AR_z} = & -\sin(Az)\cos(EI)((S\xi'S\zeta - C\xi'S\eta C\zeta)C\alpha C\beta - (S\xi'S\eta C\zeta + C\xi'S\zeta)S\alpha C\beta + C\eta C\zeta S\beta) - \\ & \cos(Az)\cos(EI)((S\xi'S\zeta - C\xi'S\eta C\zeta)(S\alpha C\gamma + C\alpha S\beta S\gamma) + \\ & (S\xi'S\eta C\zeta + C\xi'S\zeta)(C\alpha C\gamma - S\alpha S\beta S\gamma) - C\eta C\zeta C\beta S\gamma) - \\ & \sin(EI)((S\xi'S\zeta - C\xi'S\eta C\zeta)(S\alpha S\gamma - C\alpha S\beta C\gamma) + \\ & (S\xi'S\eta C\zeta + C\xi'S\zeta)(C\alpha S\gamma + S\alpha S\beta C\gamma) + C\eta C\zeta C\beta C\gamma) \end{aligned} \quad (22c)$$

Equations (22a) through (22c) are then substituted into Equations (1) and (2) for the exact solution to the aspect angles of an aircraft with an in flight roll of ζ , pitch angle of η , and heading of ξ . The aircraft is at Azimuth (Az) and Elevation (EI) and the platform of the radar is unlevel with a roll of γ , pitch of β , and north offset of α .

BIBLIOGRAPHY

1. Caraway, W. D. and Abell, D. C., "A Method for the Determination of Target Aspect Angle with Respect to a Radar", U. S. Army Aviation and Missile Command, Technical Report RD-MG-96-32, April 1996.

INITIAL DISTRIBUTION LIST

	<u>Copies</u>
IIT Research Institute ATTN: GACIAC 10 W. 35 th Street Chicago, IL 60616	1
AMSAM-RD, Ellen Mahathey	1
AMSAM-RD-OB-R	15
AMSAM-RD-TI (Tech Info)	1
AMSAM-RD-MG, Dr. James Bradus	1
Dr. Paul Jacobs	1
AMSAM-RD-MG-RF, Mr. David Abell	3
Mr. Will Caraway	3
AMSAM-L-G-I, Mr. Fred Bush	1