

293033

JPRS 84199

25 August 1983

East Europe Report

SCIENTIFIC AFFAIRS

No. 787

19980911 108

FBIS FOREIGN BROADCAST INFORMATION SERVICE

REPRODUCED BY
NATIONAL TECHNICAL
INFORMATION SERVICE
U.S. DEPARTMENT OF COMMERCE
FALLS CHURCH, VA. 22161

140
2/10/83

NOTE

JPRS publications contain information primarily from foreign newspapers, periodicals and books, but also from news agency transmissions and broadcasts. Materials from foreign-language sources are translated; those from English-language sources are transcribed or reprinted, with the original phrasing and other characteristics retained.

Headlines, editorial reports, and material enclosed in brackets [] are supplied by JPRS. Processing indicators such as [Text] or [Excerpt] in the first line of each item, or following the last line of a brief, indicate how the original information was processed. Where no processing indicator is given, the information was summarized or extracted.

Unfamiliar names rendered phonetically or transliterated are enclosed in parentheses. Words or names preceded by a question mark and enclosed in parentheses were not clear in the original but have been supplied as appropriate in context. Other unattributed parenthetical notes within the body of an item originate with the source. Times within items are as given by source.

The contents of this publication in no way represent the policies, views or attitudes of the U.S. Government.

PROCUREMENT OF PUBLICATIONS

JPRS publications may be ordered from the National Technical Information Service, Springfield, Virginia 22161. In ordering, it is recommended that the JPRS number, title, date and author, if applicable, of publication be cited.

Current JPRS publications are announced in Government Reports Announcements issued semi-monthly by the National Technical Information Service, and are listed in the Monthly Catalog of U.S. Government Publications issued by the Superintendent of Documents, U.S. Government Printing Office, Washington, D.C. 20402.

Correspondence pertaining to matters other than procurement may be addressed to Joint Publications Research Service, 1000 North Glebe Road, Arlington, Virginia 22201.

JPRS 84199

25 August 1983

East Europe Report

SCIENTIFIC AFFAIRS

No. 787

FBIS FOREIGN BROADCAST INFORMATION SERVICE

25 August 1983

EAST EUROPE REPORT SCIENTIFIC AFFAIRS

No. 787

CONTENTS

INTERNATIONAL AFFAIRS

Soviet-Bloc Scientific-Technical Development, Application Described (Various sources, various dates)	1
Mutually Favorable Technology Transfer Joint Coal Liquefaction Research New Laser Application, by Feliks Danilovskiy	
Development of Soviet Albatross Space Transport System Described (Zhigniew Paprothy; ASTRONAUTYKA, No 1, Jan 83)	5

CZECHOSLOVAKIA

Protein Production From Nontraditional Resources Viewed (Ctibor Perlin; PLANOVANE HOSPODARSTVI, No 4, 1983)	10
--	----

HUNGARY

USSR Scientist on Nuclear Research Cooperation (A. P. Aleksandrov Interview; MAGYAR HIRLAP, 16 Jul 83) .	21
Plans for Production of Variety of Integrated Circuits Elaborated (HETI VILAGGAZDASAG, No 31, 30 Jul 83)	24
Briefs Telephone Factory Makes Personal Computers	28

POLAND

Planner Assesses Scientific Research Development, Application (Jan Kuczma Interview; TRYBUNA LUDU, 20 May 83)	29
--	----

Recent Scientific-Technical Developments Described
(Various sources, various dates) 32

New Technical Progress Strategy, by Adam Peszko
Optic-Fiber Technology, Production, by R. Wolak
Airless Tire Production
Parapsychology Movement, by Jerzy Kubiak
Ocean Mineral Research

SOVIET-BLOC SCIENTIFIC-TECHNICAL DEVELOPMENT, APPLICATION DESCRIBED

Mutually Favorable Technology Transfer

Warsaw ZYCIE WARSZAWY in Polish 4 Jul 83 p 7

[Article by the Soviet Press Agency APN, specially for ZYCIE WARSZAWY:
"From the USSR Experience: Technological Transfer Is Mutually Profit-
able"]

[Text] The West currently tends to overestimate the role of technological import in the scientific and technological development of the USSR and other socialist nations. Multimillion dollar figures are cited, allegedly saved by the Soviet Union through the utilization of resources to the detriment of the West's vital interests. One questions whether this is in fact true.

"It is true, but only partly so," says Oleg Bogomolov, member of the Academy of Sciences of the USSR. "In this case, not only the USSR, but the West also has profited. It is true that in equipment and machinery the trade balance has been in favor of the West, but as far the worth of technology in the form of licenses is concerned, the export and import of scientific and technological items during the past five years (1976-80) has been more or less equal. The use by the West of Soviet basic research potential is difficult to evaluate. For this reason, among scientists of various countries (including the United States) the prevalent view is that it is impossible to measure precisely the value of bilateral transfer of technology, and that this exchange is equally valuable to the West as it is for the East."

Oleg Bogomolov believes that one should not abstain from using the advantages of international technological exchange, this important source of technological progress and cost reduction in the face of recent wave of discriminatory restrictions against socialist nations in this area. He does not want to dramatize this fact, because he believes that common sense will finally prevail, as it has so many times in the past. The scientist believes, nevertheless, that the CEMA countries should be more selective in their plans for cooperation with the West; that they consider reliability of these partners.

Relationships with the CEMA are free of discrimination and promote scientific and technological integration of socialist nations. Thanks to cooperation in computer technology, progress in the past five or six years equalled that of the previous 25 years. The multilateral cooperation now encompasses some 3,000 scientific and technical centers conducting an average of 2,000 annual projects, with 200-300 new or improved designs of machines, equipment and plant systems, and 100-150 industrial processes, and 100-120 new kinds of materials and substances.

Scientific and technological cooperation between socialist nations has been proven to facilitate reduction of dependency on imports from the West. For instance, working on industrial catalysts, positive results have been obtained with developing a group of catalysts for ammonia production in the GDR. Recommendations have been drawn up on this basis for all CEMA nations, allowing to replace catalysts imported from the West.

For the 1980's, CEMA nations have outlined a program of intensive industrial coal production and scientific and technological cooperation which covers main lines of technological progress. An important place is held by development and application of technologies which would reduce labor requirements, as most CEMA nations are experiencing manpower shortages. This involves automation of industrial processes based on digital equipment, introduction of manipulator robots and other means of mechanization of labor-intensive processes and loading/unloading operations.

A promising form of cooperation is joint research groups. One such group is the Design Bureau (USSR, GDR and Czechoslovakia) involved in the development of equipment and production flow lines for stamping sheet metal articles. This has resulted in stamping equipment of the highest quality. Time taken up by the design of new technological equipment has been reduced.

Joint scientific and technological activity can also step up the efforts to surmount the gap in certain areas of technical scientific equipment between the East and West.

The above are some of the problems of developing scientific and technological potential of the USSR and other CEMA nations involved in their participation in international cooperation. As to long-term strategies for technological exchange on a worldwide level, Oleg Bogomolov believes that a different approach should be adopted in dealing with the West. Instead of purchasing equipment for individual branches of production or transportation, we should favor purchasing complete sets of equipment and production processes for certain kinds of manufactured products.

Joint Coal Liquefaction Research

Warsaw PRZEGLAD TECHNICZNY in Polish No 15, 10 Apr 83 p 7

[Article: "In the Laboratories of the Main Institute of Mining"]

[Text] Poland: Years of research on liquefaction of coal conducted by the Institute of Coal Processing of the Main Institute of Mining at Katowice resulted in further progress in this complex and expensive technological-industrial activity. Studies in the laboratory and on a large pilot production installation processing 1,200 tons per day indicate that, in Poland's present condition, the most efficient process for coal liquefaction is direct hydrogenation at medium pressures. To this end, coal from the Wisla region is suitable. Large reserves of coal are found in that region, occurring in favorable mining and geological settings; unprocessed, this coal is difficult to use because of its high sulfur, moisture and ash contents.

The process of direct liquefaction of coal from a mine run by the Jawornicko-Mikolowskie Production Association, developed by the Institute, among other things, eliminates from the process expensive catalysts. Tests indicate that the coal contains mineral components which have a catalytic action. Scientists of the Institute are considering building a combined enterprise that would gasify and liquefy coal as a future model of coal processing for the nation's fuel industry. Further research on coal liquefaction is conducted by Institute scientists in cooperation with Soviet specialists. Based on a government contract for cooperation in development of a process of coal liquefaction in the current five-year period, a technical and industrial project will be completed that would include installation of an annual processing capacity of 150-200,000 tons of coal.

The results obtained thus far by the Institute of Coal Processing on coal liquefaction allowed scientists, in particular, to work out a concept of domestic production of electrode coke by a method similar to liquefaction. The final phase of the design operation included a project of a pilot plant that will generate powdered coal for foundry usage, "Kogran" and "Koform."

New Laser Application

Lublin SZTANDAR LUDU in Polish 15 Jun 83 p 5

[Article by Feliks Danilovskiy, NOVOSTI Press Agency, for SZTANDAR LUDU: "New Laser Application"]

[Text] Polish scientists have developed an optical laser for investigation of the images of small-structure elements which help computers to "view" the microscopic structures of metals and biological tissue. This equipment improves the precision of research and reduces the time of an experiment.

No one is surprised today by the quantum oscillator, the main component of the new equipment. The concept behind this oscillator was advanced back in the 1950's. A major contribution to development of its new applications has been made by Soviet physicists Nobel Prize winner Aleksandr Prokhorov and Nikolay Basov.

Lasers are used today not only in research laboratories but also in industry. There are laser lancets used by surgeons to fight disease. Without the quantum oscillator, there would be no optical electronics creating so much excitement in computer engineering. Using electrooptical equipment, one utilizes the light beam to transmit information through fiber-optics and convert it to electric pulses.

Developing the light energy conversion designs, scientists were confronted with the problem of efficiency of sources. Incandescent lamps did not produce the desired effect when optical signals had to be converted into electric signals, and vice versa, at a rapid enough pace. This is where lasers became irreplaceable. Their coherent, narrowly directed light beam carries tremendous power. Quantum oscillators became the basis of computers with electrooptical equipment. They contain electronic integrated circuits with special optical transducers.

These units will become important in future computer engineering. Today, electronic intelligence can analyze the images of thin fragments of various materials. The laser has an important part to play in this, too. It is incorporated into a coherent optical device which helps the computer to see the microscopic microsection elements.

The "rapid eye" of the electronic brain is, normally, a television camera. Such cameras transmitted the image of an examined object to the electronic logic, which in turn analyzed and processed the light signals, transmitting the data on the structure of the object. Such equipment had one shortcoming. ... The precision of the image transmitted to the electronic brain greatly depended on the illumination of the object. If it was not lit sufficiently, the image was unclear. Its precision also depended on the light-reflecting and transmitting properties of the object. This made experiments longer and more difficult. Soviet scientists proposed to use, instead of television cameras, a special optical device intended for electronic microcomputers PS-300. The principal components are the modulator and the deflector. The unit adjusts the direction of the laser beam according to a special program. As a result, the beam moves in a certain direction, lighting the explored object. The reflect beam falls into photoreceiving units, which transmit the electric pulses to the computer.

Specialists believe that the new optical system will be a useful tool for metallurgists, biologists and precision mechanics engineers. Investigating the properties of metals with this instrument, scientists will identify metal structure rapidly and accurately. Biologists will be able to conduct biochemical analyses rapidly and observe structural changes of living tissue. In precision mechanics it will be used to teach automata to recognize manufactured articles moving on the conveyor belt of a production line.

9922
CSO: 2602/33

DEVELOPMENT OF SOVIET ALBATROSS SPACE TRANSPORT SYSTEM DESCRIBED

Warsaw ASTRONAUTYKA in Polish No 1, Jan 83 pp 17-18

[Article by Zhigniew Paprothy: "A Soviet Shuttle Craft?"]

[Text] Now that the U.S. multiple-use space transport system has completed a series of test flights and the operational phase of the program is about to begin, Soviet efforts to develop a similar system are being mentioned in the western technical journals more and more frequently. First-hand information has been extraordinarily meager until now. (In Poland, one such source was an article which appeared in one of the issues of KRAJ RAD [Soviet Union Affairs-illustrated].) Further details were provided in a publication that was coauthored by G.B. Sinyaref and published in the second half of 1982 in the collective work "K.E. Tsiolkovskiy and the Scientific-Technical Progress" (Moscow, 1982, Nauka). This publication is certainly not the latest report on efforts to develop a Soviet version of the shuttle craft, because it dates back to 1975, when it was presented at the annual conferences dedicated to the contribution of Tsiolkovskiy in various areas of science and technology. However, because the authors, in the version published in the aforementioned book, cite works dating from 1976 and 1978, it should be assumed that the transport system design, which they present, is still being developed, and the text of their publication has been at least partially updated.

General Characteristics

A characteristic feature of the space transport system presented in the aforementioned work is its launching in a horizontal mode from the surface of the water (this explains the name of the design: "Albatross"). In the author's opinion, such a design has many advantages. The most important ones include the absence of any need for launch installations which are expensive to construct and operate and the possibility to transport the large structural components of the Albatross exclusively on waterways (this is far less expensive and sometimes the only way possible). In launching from the surface of the sea, the direction of flight is not limited by the spatial orientation of the launching strip. Moreover, the length of the strip needed for the appropriate acceleration of the Albatross before launching is also unlimited.

Design

The Albatross space transport system is composed of three parts (Diagram 1): two of them form the so-called orbital aircraft, while the third part is the acceleration module, which provides the appropriate, initial velocity for the orbital aircraft and plays a role similar to that of the solid-fuel rockets used in the launching of the U.S. space shuttle. The authors of this collective work refer at this point to K.E. Tsiolkovskiy, who was the first to propose the use of ground facilities for the initial acceleration of spacerockets. The two parts of the Albatross that comprise the orbital aircraft, correspond to the two stages of a rocket vehicle. They are the rocket transport aircraft and the rocket plane which is actually the spacecraft placed "piggyback" on the transport aircraft. The orbital aircraft (i.e., the orbital aircraft plus the rocket plane), in turn, is placed on the acceleration module--a rocket-propelled boat equipped with two types of hydrofoils.

At low velocities (up to 50 meters per second), most of the hydrodynamic lift force is provided by subcavitation hydrofoils which are similar to those used on ordinary hydrofoil crafts. These hydrofoils do not allow cavitation which occurs at high velocities and causes strong vibration leading to the disintegration of the structure. For this reason, the acceleration module, at velocities exceeding 50 meters per second moves on hydrofoils of another kind: supercavitation hydrofoils, which operate in a mode of developed cavitation. They make it possible to attain a velocity of approximately 200 meters per second.

In designing the orbital aircraft, the following data were assumed: launching mass of the orbital aircraft--1,250 tons; payload mass lifted into orbit--20-30 tons; height of orbit--200-220 kilometers; inclination of orbit--40-45 degrees; launching velocity of the orbital aircraft--140-200 meters per second; maximum gravity load--3.35 g.

The rocket engines of both "stages," the orbital aircraft and the acceleration module, are to be powered by liquid oxygen and liquid hydrogen. The use of this particular fuel assembly in launchings from the surface of the sea is convenient, because both components can be obtained directly in the region where the Albatross is launched, if, as the authors note, a nuclear power plant is situated nearby.

Flight Course

In the water-surface acceleration phase, only the engines of the acceleration module are in operation. The Albatross initially starts out as an ordinary hydrofoil craft. After attaining a velocity of 30 meters per second, it rises on its subcavitation hydrofoils until it reaches a velocity of 50 meters per second; above this velocity, it moves exclusively on the supercavitation hydrofoils. Calculations show that the orbital aircraft can take off after attaining a velocity of 140 meters per second and an angle of incidence of 16 degrees. Therefore, 20 seconds before this speed is attained, the nose of the orbital aircraft is raised by a special hydraulic lift in order to attain the

necessary angle of incidence. At 140 meters per second, the engines of the transport aircraft are turned on, and the launch of the orbital aircraft occurs. After the orbital aircraft is separated from the acceleration module, the latter is towed to a dock, where it can be made ready for the next launching of the Albatross. The first stage of the orbital aircraft --the transport aircraft--lifts the rocket plane to an altitude of 55-60 kilometers and provides it with a velocity of 2000-2200 meters per second. Then separation of the rocket plane occurs, after which the transport aircraft glides back to earth and lands at a regular airfield. The sustainer engines of the rocket plane that are started immediately after separation from the transport aircraft accelerate it to its initial space velocity, thereby making it possible to attain a nominal orbit (altitude-220 kilometers; angle of incidence-45 degrees). After completion of the orbital mission, the rocket plane returns to earth on a trajectory which allows the velocity to be reduced and lands on a concrete runway of an airfield.

The principal design features of the Albatross are presented in Table 1.

Computations which have been completed to date for the Albatross space transport system include: ballistics calculations; calculations of thermal characteristics for all phases of the flight of both stages of the orbital aircraft; and computations pertaining to the movement of the acceleration module up to a velocity of 200 meters per second. Designs have also been made for rocket engines with a thrust force of 100, 250 and 300 tons. The mass characteristics have been obtained, and the geometric parameters have been determined for the individual elements of the Albatross system. Strength computations have been completed for the basic structural elements of the system, and the specifications for a launching complex required for implementing the design have been determined. One of the results of this work is the precise determination of 20 tons as the weight for the mass of the payload. In the authors' opinion, the Albatross multiple-use space transport system is not inferior in terms of mass and energy to other prospective systems of the same category and even has a certain superiority over them because of the advantages of launching in a horizontal mode from the surface of the sea.

(Based on the article by G. B. Sinyaref and coauthors: "Transportnaya Kosmicheskaya sistema 'Al'batros':. [Albatross Space Transport System])

Figure 1.

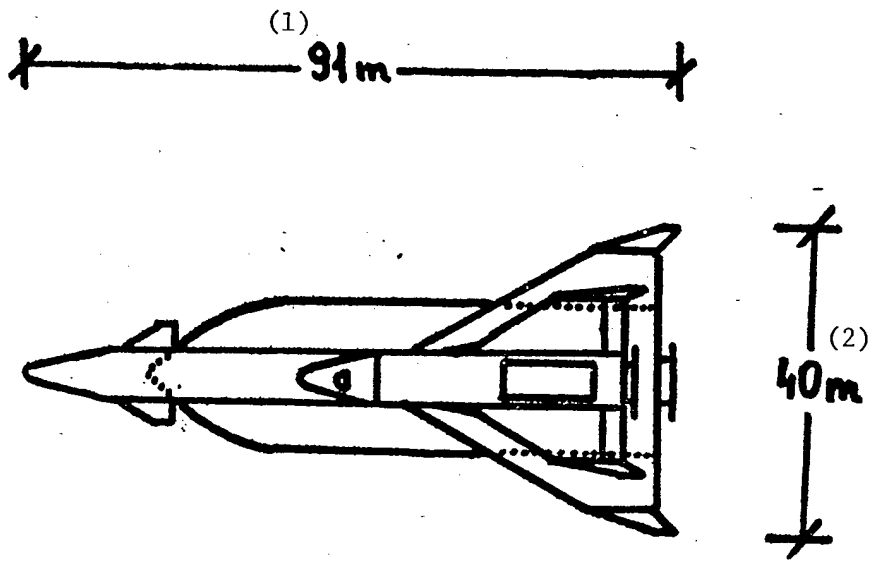

Rys. 1

KEY: (1) 91 meters
(2) 40 meters

Figure 2.

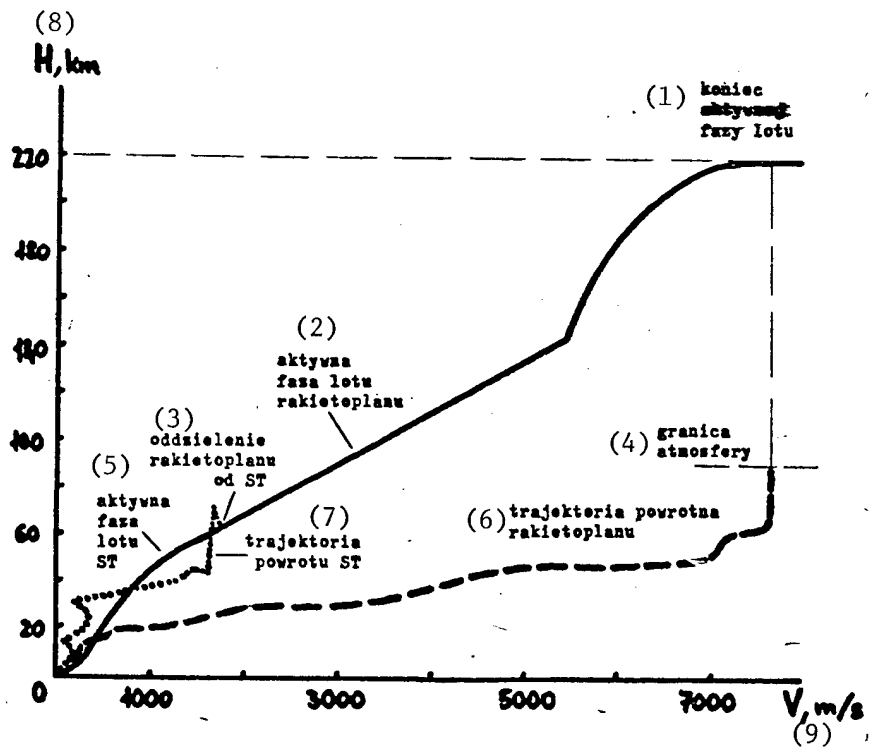

- KEY: (1) End of active phase of flight
 (2) Active phase of flight of rocket plane
 (3) Separation of rocket plane from transport aircraft
 (4) Boundary of atmosphere
 (5) Active phase of flight of transport aircraft
 (6) Return trajectory of rocket plane
 (7) Return trajectory of transport aircraft
 (8) Altitude in kilometers
 (9) Velocity in meters per second

Table 1.

Characteristics	Orbital aircraft		Acceleration module
	Transport aircraft	Rocket plane	
Launching mass, tons	1,250	320	550
Fuel mass, tons	675	238	154
Mass on landing, tons	255	82	396
Total thrust, tons	938	512	(acceleration module--fuel) 1,800
Number of engines	4	5	6
Initial velocity, meters per second	140-150	2,000-2,200	0
Final velocity, meters per second	2,000-2,200	7,800	140-150
Altitude at beginning of active phase, kilometers	0	55-60	-
Altitude at end of active phase, kilometers	55-60	220	-
Length, meters	91	48.5	70
Wingspan, meters	40	25.3	-
Wing surface area, square meters	850	428	46.5
Wing load, kilograms per square meter	1,500 (launch)	200 (landing)	(hydrofoils) -

12209

CSO: 2602/30

PROTEIN PRODUCTION FROM NONTRADITIONAL RESOURCES VIEWED

Prague PLANOVANE HOSPODARSTVI in Czech No 4, 83 pp 37-45

[Article by Eng Ctibor Perlin, ScC, Research Institute for Economy of Agriculture and Nutrition, Prague: "Prospects for the Production of Protein for Food From Nontraditional Sources in the CSSR"]

[Text] The current as well as the future situation of protein resources is one of the most vital problems in human and animal nutrition all over the world. The consumption of food in the CSSR has been shifting gradually from vegetable to animal resources, as demonstrated above all by the growing consumption of meat and meat products which increased from 56.8 kg per citizen per year to 85.6 kg per citizen per year, expressed in values of the meat on the bone. In the same way, the consumption of milk (in liquid milk values) increased from 173 liters to 233 liters and that of eggs from 179 to 316 eggs.

This trend in consumption was also demonstrated by a higher supply of protein per average citizen, which increased from 86 g per day to values just below 100 g (in 1980, 96.9 g). At the same time, mainly animal proteins increased markedly--from 41.2 g to about 57 g, which means that in 1980 animal proteins covered almost 59 percent of the total consumption of proteins. The extreme trend toward the consumption of animal proteins was further reflected in an undesirable phenomenon, namely, a conspicuous consumption of lipids along with the proteins. Expressed in dietary terms, it rose from 102.5 g per citizen per day to 117.7 g per citizen per day, i.e., more than 23 percent above the recommended nutritional intake.

Next to the adverse consequences of increased consumption of animal proteins, almost always connected with an excess of lipids in the raw material, the growing demand for foods of animal origin produces a negative economic impact. Further increase of the production of animal proteins by traditional methods in agriculture, i.e., expanded cattle- and hog-raising, is curtailed by the limited resources of fodder and, moreover, proteins are converted under extremely adverse conditions connected with considerable losses. Livestock production is very demanding, as demonstrated by the following facts:

--8.2 g of proteins in fodder are required on the average for the production of 1 g of animal protein;

--in 1980 the subsidies for the production of animal proteins exceeded Kcs 9 billion;

--losses and unused resources of proteins in production, processing, circulation and consumption amount to as much as 40 percent;

--along with the growing consumption of traditional resources of animal protein (meat, milk), the consumption of fats and, thus, also of energy has undesirably increased.

For those reasons, it seems most feasible to cut the losses of protein raw materials, especially those of animal origin, to use the untapped assets of proteins directly in human nutrition as concentrates (most efficiently as additives in meat products and convenience foods), and finally, to expand utilization of waste in nutrition.

The growing demands for protein-based foods underscore the importance of all resources of proteins, even those that remain underutilized. Food production throughout the world is making a necessary shift of its raw material base toward nontraditional use of the existing resources of proteins and toward potential nontraditional resources. Under the conditions in the CSSR, it is imperative to develop unconventional protein products in the future, particularly as an advanced method for the solution of meat consumption and for the use of proteins in many other food products.

Science, research and technical development are intensively developing methods to isolate proteins of various origin, to modify their nutritional, gustatory and functional values and to use isolated proteins in various areas of food production. Their applicability depends on increasing their nutritional value, on replacing protein raw materials that are either in short supply or expensive, and on improving the colloidal chemical properties of foodstuffs.

In terms of nutrition, new protein products must have an appropriate amino acid structure and cannot contain antinutritional factors, such as enzyme inhibitors or toxic compounds. In their gustatory appeal, proteins must have pleasant smell, taste, color and functional properties. Their main sensory requirement is a light color and neutral taste so that the characteristic gustatory properties of meats and other products not be affected by protein additives. Among the absolutely necessary functional properties of protein concentrates are their ability to bind water and fats, to form gels and emulsions under various conditions, to stabilize and thicken emulsions, as well as masticatory and whipping qualities, solubility, viscosity, etc.

Animal Resources of Nontraditional Proteins

Our meat industry has its own untapped resource in the blood and bone proteins which it can utilize. Accounts of recovered blood used in slaughterhouses demonstrated that, at the current level of slaughterhouse production, about 10,000 tons of proteins may be obtained annually from that source. Thus far a bare minimum of that amount has been used in human diet; only 2.14 percent of recovered blood was utilized in 1980 (2.58 percent in the CSR and 1.12 percent in the SSR).

Total lack of facilities for industrial collection of blood for food production is the main hindrance to more widespread use of blood in human nutrition; furthermore, blood-processing facilities and legislative amendments are needed. The most promising prospect for the nearest future involves separated plasma used as technological water (as ice flakes) in meat production. A plan for such a facility, which calls for imported technological equipment, demonstrated the advantages of the proposed design in its economic section.

With an annual volume of 1 million litres of collected blood, the output of meat products will be up 200 tons and the projected annual profit will be Kcs 3.8 million. Therefore, a facility can process 1,000 tons of blood yielding 60 tons of proteins to be added directly into meat products. Since blood is available in about 12 meat-processing concerns in the CSSR, after the planned technology has been tested in operation and fully implemented, the proposed technological facilities may supply 720 tons of blood proteins (approximately 2,400 tons of meat products).

It seems unrealistic to use the blood cell fraction directly in human diet at present or in the near future, although that fraction is richer in proteins than the plasma. Some of the following problems must be resolved before this component may be used in food products:

--the treatment of blood cells by hydrolysis, splitting of the heme and its absorption, so as to produce a hygienically acceptable concentrate for immediate use;

--the production of fatty emulsion with milk proteins as additives in meat products (at present even homogenized milk protein concentrates are not available);

--the production of stabilized blood dye as an additive to meat products.

Individual options for the utilization of the blood cell fraction are independent on each other.

In conjunction with the problems related to direct use of blood in human diet, it should be underscored that currently this waste in the food industry is used as feed. Here it may be useful to consider replacing the energy-consuming method of drying blood or the blood cell fraction by chemical conservation which helps cut energy consumption to 3 percent of the total energy required for drying and which may better utilize this valuable protein component, if the economic incentives are advantageous. Chemical conservation of blood may be introduced without extensive investments, with machinery and equipment manufactured in the CSSR, however, it calls for organizational solutions of deliveries of the processed feed component to fodder storage centers.

Annual production of technical bones in our meat industry comes near to 60,000 tons, which is 36.5 percent of the potential output of bones of slaughter livestock. It cannot be assumed that this amount and share will substantially increase in the coming years, so long as our meat industry does not drastically expand cutting on location and sales of specially packaged cuts of ready-to-cook meats.

The concept of collecting and processing the technical bone material is based on the most efficient conversion of bones into gelatin. The proposed gelatin factory in Liptovsky Mikulas will lower the demands for imported gelatin even if its consumption increases; it will even make it possible to export certain types of gelatin. Once achieved, this objective will reduce the need for payments in foreign exchange for imported gelatin (amounting to Kcs 28 million); on the contrary, it will bring in foreign exchange (Kcs 36 million).

The CSSR gelatin production requires that the bones be crushed into defatted bone meal. It is necessary to begin here with absolutely reduced transport costs, maintaining the quality of the technical bone material, observing the regulations of environmental protection, and using technological equipment made in the CSSR. A concept prepared by the FMZVz [Federal Ministry of Agriculture and Food] deals with all those problems.

Moreover, it seems that the plan for the construction of a factory producing gelatin from poultry feet may have application in the future. With the production of 300 tons of edible gelatin from poultry feet in the Slovak Poultry Industry Enterprises, annual profits of the processing factories are projected at Kcs 2.3 million; as compared with the production of meat-bone meal, the value of the processed raw material was estimated to be Kcs 8.88 million higher, and as compared with imports of an equivalent amount of gelatin, the profits will amount to Kcs 16 million in foreign exchange. The equipment for the production of gelatin from poultry feet is simpler than bone processing and does not call for any imported technology. The resources of the raw material will enable the CSR food industry to produce twice as much of the raw material from poultry than the SSR.

As for milk, more than 99 percent of its fats, but only 75 percent of its proteins, are used in human diet. A considerable part of proteins is used for feeding; on the average, its share exceeds 36,000 tons of proteins for feeding annually (with 3.2 percent of estimated protein contents in milk).

Some of these protein resources must be used in agricultural production to feed young animals. Of the available amount, which is dried by energy-consuming processes and then used again as feed, at least 50 percent may be used directly in human nutrition. However, that calls for additional technological processing, especially in terms of concentrating valuable components (proteins) and removing components that are undesirable from the viewpoint of the utilization of protein concentrates (lactose) but which may be efficiently utilized in other forms.

Milk protein concentrates may be obtained by means of clotting (casein, caseates, coprecipitates) or ultrafiltration which produces soluble or insoluble components with various functional properties. The construction of a sodium caseate factory in the CSSR with the following indicators is planned:

--annual processing of 117.2 million litres of milk, and production of 3,300 tons of caseates and 7,700 tons of dried whey;

--with the use of caseates in meat products and of whey for feed, 11,760 tons of meat will be produced, while dried skim milk used directly for feeding purposes produces only 3,040 tons of meat;

--total investments amount to Kcs 22.80 per kg of meat in the caseate variant and in the variant for direct feeding to Kcs 44.08 per kg of meat;

--the costs for the production of the caseate variant amount to Kcs 12.80 per kg of meat, with feeding to Kcs 23.76 per kg of meat.

It should be added to this analysis that whey is less nutritious than dried milk, especially in terms of protein contents, and that the production of caseates along with dehydrated whey consumes considerable energy. With the alternative production of thickened milk whey, however, the consumption of energy approached the amount of energy used for dehydration of milk. In view of the resources of raw materials, the potential for using whey for feeding, and deliveries of machinery manufactured in the CSSR, it seems more feasible to plan for the production of milk protein concentrates in several small factories with daily capacities from 50,000 to 100,000 litres of milk. Milk proteins may also be used directly in dairy products (cheeses) which replace meat products in consumption, or in liquid milk products as gustatory substitutes for fat.

Vegetable Resources of Nontraditional Proteins

Economic demands on the production of animal products, mainly meat, forced world producers of meat and convenience foods containing meat to search for less expensive substitutes of meat proteins whose functional properties, however, preserve or even improve the technological, nutritional and gustatory properties of final products. Here concentrated vegetable proteins found acceptance even beyond their use in meat products.

One of the main advantages of vegetable proteins is their relatively good availability and, moreover, the fact that their use does not raise the consumption of fats, as is the case with practically all animal proteins.

For industrial use, vegetable proteins must be preprocessed according to several methods: functional properties and potential application of the resultant products vary.

The simplest method of processing is ordinary grinding and sifting, with meal as the resultant product. Meal may be processed further, for example, by extrusion which yields a porous product able to absorb considerable water. On another level, appear protein concentrates containing usually about 70 percent proteins; their production follows the methods of elution and removal of accompanying undesirable components (saccharides) in the isoelectric point of proteins that are the least soluble under such conditions. Isolates containing about 90 percent protein are produced mainly in several stages by extraction of proteins from the raw material and by their subsequent coagulation. The most complex technology, texturation, consists of weaving the

fibres of vegetable proteins, making it possible to dye and flavor them; the products are on the level of meat analogues.

In our situation, wheat proteins are among our most important resources. Wheat grains contain about 12.5 percent, wheat flour about 11.5 percent (depending on the degree of milling). A significant indicator of the species of wheat in food industry is the content of the protein fraction of gluten whose contents and quality essentially affect the quality of bakery products. In nutritional terms, however, wheat proteins on the whole are characterized by very low contents of lysine (42 percent of reference protein) and threonin (74 percent of reference protein).

The use of wheat, and thus also of wheat proteins, in the food industry is decidedly not one of the nontraditional methods. Its new aspect is the production of wheat proteins in concentrate form and its application in other food products. As for wheat protein concentrates, the production of wheat gluten is practically the only one thus far to have found broad application, namely, in the production of wheat starch. Its side product, vital gluten containing 81 percent proteins in its dry mass, can be used in meat products. The disadvantage of this process is that considerable amounts of the dry mass are lost during the process of production and that wheat of the best nutritional quality with high gluten contents is needed for this purpose.

For that reason, in the future a better method will involve potential use of wheat species grown for industrial processing based on separation of most of the proteins by hydrodynamic treatment of the suspension of the flour in water, which does not require gluten of top quality because the process of separation does not call for making dough. The proposed method produces a wheat protein concentrate containing 35 percent proteins in the dry mass, suitable to replace 2 parts of meat with 1 part of the concentrate, and starch raw material which may be either processed further by conventional methods in the starch industry, or hydrolyzed for feeding purposes. Production of the wheat protein concentrate, including efficient utilization of its starchy components, has now reached a stage where a pilot plant for its testing is under construction, and potential use of all resultant products in the food industry and for feeding purposes is being studied. Presumably as early as in 1985 and 5,000 tons of wheat protein concentrate will be available in our food industry.

--An important resource of vegetable proteins is the seed of oleaginous crops. The most widespread are soy beans, representing more than one-half of the production of oleaginous seeds worldwide, precisely because they also are a valuable source of protein. About 2 percent of potential soy proteins are used at present in human diet. In their composition, they resemble proteins of muscle tissues (high contents of lysine amino acids, low contents of sulfuric amino acids).

However, the climate in the CSSR prevents us from considering more extensive use of soy proteins directly in human nutrition, although it is presumed that soy bean cultivation in south Slovakia and south Moravia will be expanded in the future, if the conditions are economically advantageous. A part of the

groats obtained while pressing soy oil may be used to produce food protein concentrates from soy beans. At present, at least 25,000 tons of imported soy beans are processed every year to produce soy oil which, together with sunflower oil, is an essential factor in the balance of fats, especially since it provides an adequate supply of linoleic acid in the diet. Soy groats may be processed either into soy protein concentrates or into extruded defatted soy meal. Technological equipment for either method and the license for the extruded meal must be purchased abroad. The production of extruded meal which may replace 2 parts of meat in meat products is more advantageous due to higher yield of protein, lower cost and simpler technology. Although the concentrates may replace 2.5 to 3 parts of meat, their production is more complicated.

--Another advantage of the technology for processing proteins from soy groats is that after certain fairly simple adjustments this equipment may also process in the future proteins of our most common oleaginous crop--oil rape. The amino acid composition of rape proteins surpasses even that of soy proteins, however, there are problems with their immediate use because of the high contents of antinutritious substances, glucosinolates, whose removal still involves very laborious industrial processing and is therefore expensive. Crop improvement is a potential solution; reducing the contents of undesirable glucosinolates may not be an impossible, though apparently a long-range prospect. Obvious preconditions call for the maintenance of high oil contents, resistance and yields. Canada, Sweden and France have already advanced in that direction.

--Another option in our circumstances is utilization of pea protein. Peas contain 22-26 percent proteins and yield 2 to 3 tons per hectare. Experience abroad has shown that sifting may yield pea meal with 46 percent proteins and extraction produces concentrates with 65 percent pea proteins. The use of peas (or other such legumes), however, has not reached even the stage of research, although the biological value of pea proteins is equal to that of soy proteins.

--Potato proteins, which are the most advantageous from the biological point of view, have very low contents of proteins in the raw mass (2 percent) and thus, their production is more difficult. Thus far, efforts to utilize them have failed because of the necessary concentration of large amounts of water with low retention of proteins. We cannot count on industrially processed potato proteins either in human diet or in animal nutrition without expensive reconstruction of our starch industry and without introducing new technologies in the production of potato starch, which is a prolonged and costly process. A certain method for utilization of the valuable proteins contained in potatoes as fish food developed from the use of waste water for feeding purposes following spontaneous anaerobic fermentation of the water under strictly controlled contents of oxygen in the water.

Proteins in Biotechnological Production

From the perspectives of industrial production, utilization of the proteins of unicellular organisms seems the most feasible method for the future. It is not

a new idea to use microbes in human diet. We are familiar with the technological processes of beer brewing, winemaking and vinegar-making, yeast fermentation, etc. Nevertheless, the proposal to use the extensive production potential of microorganisms for the production of many substances, among them also proteins, on an industrial scale and to use nontraditional and waste substrates represents a novel concept. After all, of all traditional animals poultry reproduces proteins most rapidly, doubling the amount of proteins in 1 month (hogs in 4 months), while microbes double their protein in 1 to 6 hours. Other advantages of this method of production are the rapid, well-controlled production in industrial conditions, a high share of proteins in the dry mass, the opportunity to select appropriate strains, independence from the external environment, and high labor productivity. According to medical experts, it is preferable to select for such purposes yeast cultures already conventionally used (in many cases they are a natural factor in the diet); as compared with bacterial cultures, they also reduce the risk of undesirable biochemical processes and thus, the development of abiogenic compounds and toxins. Nevertheless, several processes using various strains of bacteria, fungi, algae, etc. for these purposes have been reported.

From the viewpoint of the raw material base, in all probability, processing of conventional yeast substrates (molasses, glucose, brewery and distillery waste) and of expensive petrochemical raw materials (n-alkanes, crude oil, oils, natural gas, ethylene) will steadily taper off. Waste materials from cellulose production will gradually decline because of progressive transition toward the more efficient sulphate method.

Ligno-cellulose materials are the most ample untapped resources of raw materials for the production of microbe proteins. The annual amount of unused resources of the biomass in forest economy is estimated at 3 million tons of dry mass (5 million tons of fresh mass), of which about 2 million tons of fresh mass in the lumber industry alone. For that reason, as long ago as in 1965-1967 two investment plans for the production of yeast for feeding produced from wood scraps in the lumber industry were prepared. The technology planned according to the experience in the USSR proceeded from acid hydrolysis of lignocellulose materials and was tested in its laboratory version, but was not tested in pilot plants. In addition to the principal product--feed yeast (dry mass yielded 20 percent of the raw material dry mass)--it was expected that the lignine waste would be used in the production of organic-mineral fertilizers (yield 30 percent). It should be mentioned that basic research in the SSR is planning a target project entitled "Comprehensive Utilization of Lignocellulose" which adopts the method of chemically treated phytomass and also studies modern biotechnological approaches.

--An important modern source of raw materials for fermentation substrates, whose composition resembles lignocellulose materials, is communal refuse in modern settlements without local heating system. For example, the amount of solid waste in Bratislava is estimated at 100,000 tons annually, half of which is lignocellulose waste. In large residential compounds, such solid waste may become a source of fermentation substrates for the production of microbe proteins, whereby the process of sanitation would be partly transformed into an efficient industrial complex producing materials for animal and human nutrition and for the chemical industry.

--The most widespread has become the production of microbe protein biomass for feeding purposes. For its direct use in food industry it is necessary to eliminate first the main hygienic problems, such as its high contents of nucleic acids, dietetically unacceptable abiogenous fatty acids (odd numbers of carbons, trans-isomers, etc), allergens, to reduce the unsuitably high ash content and to prevent potential toxic peptids. In this direction, the task to study the conditions for the production of yeast proteins for human nutrition has been successfully completed. The result is new technology for the production of comestible proteins from the *Torulopsis utilis* yeast on sulphite eluates, enzymatically hydrolyzed, separated in the form of yeast milk, and desiccated in spray dryers to 90 percent dry mass. The product contains at least 46 percent proteins, at most 1 percent fat, 5 percent cellulose, 5 percent ashes, 2 percent ribonucleic acid and 0.2 percent desoxyribonucleic acid. The product was approved as medically unobjectionable, tested on volunteers and accepted for potential use in meat products. Daily amounts of those proteins should not exceed 0.1 g per kg of body weight; the protein is usable exclusively in heat-processed products in amounts up to 4 percent.

--Next to the principle or the use of fermentation technologies for the production of proteins, we should mention the newly introduced method for the separation of proteins from yeast (wine) lees, which is under study in the VUP [?Research Institute for Food Industry] in Bratislava under the title of desolvation method of extraction. This method is based on the removal of the soluble coat of a high-molecular substance (protein) by means of a non-polar solvent, which reduces the solubility of the isolated substance and results in its precipitation. Wine lees undergo countercurrent extraction of the ethanol and water mixture. The advantage of this technology is the removal of tartrates and bitter substances and a single-stage production of proteins. The proposed method facilitates the production of proteins and other components, such as bitter substances, dyes, tartaric acids, etc, which find good application for the food industry and elsewhere.

Efficient Utilization of Protein Concentrates

Protein concentrates replace a certain amount of meat in meat products. The amount of the substitutes is basically determined by the contents of proteins in the concentrate and the ability of the protein additive to bind water while preserving or increasing the total amount of proteins in the product. The ability to bind water is mostly higher than required in terms of the contents of meat proteins. This estimate is based on the premise that the functional properties of protein additives meet all technological requirements.

The societywide costs involved in the production and processing of 1 kg of pork in meat production (meat and innards) are expressed in the value of Kcs 31 - 33.60, and those of beef--Kcs 51.80 - 55.50. Thus, from the societywide view, average costs per kg of meat products amount to Kcs 42.98.

Efficiency of protein concentrates used in meat substitutes in production is reviewed for comparison in the following table:

<u>Type of concentrate</u>	Price Kcs/kg	<u>Substitute for Meat Product</u>		Savings in societywide costs Kcs/kg
		<u>Kg</u>	<u>Kcs (societywide costs)</u>	
Sodium caseate	35.00	3.25	139.65	104.65
Soy concentrate	14.52	2.75	118.17	103.65
Wheat concentrate	10.00	2.00	85.94	75.94

The above data indicate that in terms of substitutes for meat as raw material the most advantageous is caseate and the least advantageous the wheat protein concentrate. However, these references concern only utilization of those meats in the meat-processing industry and make no allowance for the costs of their production. If we consider the planned wholesale price per kg of these protein concentrates, then the value of caseate is almost equivalent to that of the soy concentrate and the value of wheat protein comes close to both. The nutritional point of view, however, will always prefer lactic protein concentrates before the soy and wheat proteins.

Another question concerns the use of byproducts. Thus, for example, starch used in the food industry or starch hydrolyzates used as feed render the application of wheat proteins more efficient and, similarly, the processing of lactose or the production of lactose syrup sweeteners may upgrade the value of lactic protein.

--Nevertheless, the use of protein concentrates in the meat-processing industry is limited because this raw material may be used practically only in soft and small products in an amount up to 3 percent, in order to preserve the typical taste and technological shaping properties. The annual production of such products amounts to 200,000-250,000 tons, which makes it possible to use 6,000 to 7,500 tons of protein concentrates annually. Furthermore, to some extent they may be used in the production of boiled proteins in preference to soy and wheat proteins.

However, concentrates of nontraditional proteins may be used on a far greater scale in the development of mass-produced meals for communal dining. As concerns the technological viewpoint of the production of convenience foods, homogenous raw materials must be prepared first by the technique of meat reconstitution with the REMA or COMMITROL [expansions unknown] system. According to preliminary data, if 10 percent of the factory and school dining facilities are supplied with industrially prepared convenience foods, about 108,000 tons of such meals will be required in 1985. This is the rock-bottom minimum, while the optimum variant estimates a 20 percent coverage. The projected coverage for 1980 is at least 25 percent, i.e., 350,000 tons of convenience foods (the optimum variant which thus far does not seem realistic anticipates 50 percent coverage of consumption, i.e., about 700,000 tons). The meat component in these meals is about 10 percent; if we consider that 15

percent of nontraditional proteins in the form of concentrates may be used--which is a realistic amount in terms of technology and taste--then the consumption of nontraditional protein concentrates for these purposes would be at least 1,500 tons by 1985 and would increase in 1990 to the optimum of at least 10,000 tons of concentrates. Once more it must be underscored that the optimum means no more than 50 percent of communal dining facilities and that this estimate does not consider in the least public dining and closed systems of institutional dining services (hospitals, military units, etc) where the demand for concentrates would have to be even higher.

--This projection completely disregards the possibility of introducing in the market newly developed products as substitutes for some of the traditional meat products, with different properties and use which would require vigorous initial promotion in order to change the current traditional consumption and to introduce new habits. It is difficult to estimate the consumption of concentrates in this area because thus far no newly developed products of this type have been introduced. So far there has been only sporadic experience abroad and research in our country.

Within the approaching comprehensive solution of the program for our food industry a study is under way in the CSSR, focusing on the most efficient use of all accessible resources for the production of food so as to reduce national economic pressures on animal production and to apply new methods in our food industry in order to expand the use of available raw materials and to cut waste. Also in this sphere of problems are efforts to use untapped accessible resources of proteins efficiently and directly in human diet. Implementation of the outlined projects, however, depends on the investment capacities of our food industry and of our national economy as a whole.

9004

CSO: 2402/58

USSR SCIENTIST ON NUCLEAR RESEARCH COOPERATION

Budapest MAGYAR HIRLAP in Hungarian 16 Jul 83 p 5

[Interview with A.P. Aleksandrov, President, Academy of Sciences of the Soviet Union by Laszlo N. Sandor: "A.P. Alekdandrov, President of the Academy of Sciences of the Soviet Union Speaks. Mutually Beneficial Cooperation"]

Academician Anatoly Petrovich Aleksandrov, the world-renowned nuclear physicist, has recently celebrated his 89th birthday. His extraordinarily many-sided scientific activities have earned him 3 Lenin and state prizes. In 1975 he was named president of the Academy of Sciences of the Soviet Union, but he has continued to direct one of the most important Soviet nuclear physics research centers, the Kurchatov Institute of Moscow.

[Excerpts] Recently, A.P. Aleksandrov was presented a high-level decoration at the Moscow embassy of the Hungarian People's Republic for his efforts in furthering the development of Soviet-Hungarian scientific cooperation. Our correspondent, Laszlo N. Sandor's inquiries were directed mainly at finding out how these ties have developed in recent years and at learning how the president of the Soviet academy views the prospects for expanding cooperation. At the same time, the correspondent's first question also touched on the personal contacts between the president and Hungarian researchers.

[Answer] My personal contacts with Hungarian researchers are not new; they have been intensive and continuous--began the conversation academician Aleksandrov.--I have visited your country on several occasions and your researchers have been at home here. It was 15 years ago today that we agreed with Pal Lenard, then head of the Central Research Institute for Physics, who is now the general secretary of the Hungarian Academy of Sciences regarding future cooperation in the field of physics. We have achieved significant results since then, especially in the area of electronics. I would characterize our relations as constantly and dynamically expanding. The Central Research Institute for Physics in Budapest has done extremely valuable work in the course of its research aimed at finding ways of utilizing fusion energy. As it is well known, in the next few years we

are expecting to complete construction of the Tokamak-15 experimental facility designed to make practical use of fusion energy. The automation for this project is being prepared by Hungarian experts. I might mention that we are talking about an extremely sophisticated guiding system. Our joint activities are highly congenial and admirably friendly.

I believe that this bilateral cooperation is also extremely beneficial to our Hungarian partners since the semiconductor technologies which we have made available to the Hungarian experts are modern and can be successfully used by your researchers for their own purposes. We can report some notable starts in the area of electron-beam lithography. Under this process an electron beam is used to imprint the circuit design onto the semiconductor chip. As a result, we get high-resolution micro-designs. Significant advances have been made in miniaturization. Hungarian experts have also been using our facilities with excellent results. Naturally, it is not only with the Kurchatov Institute that Hungarian experts have exemplary relations with, but also with other institutions. We attach great value, for example, to our joint efforts in the field of computer technology. We have been able to make good use of Hungarian-made displays, but I could also mention our joint achievements in robot-technology which is extremely important for us.

[Question] In what areas do you see possibilities for expanding cooperation?

[Answer] First of all in the area of energetics, biology and biotechnology. The prospects of cooperation in nuclear energetics are also promising. There are at least 30 common topics which promise mutual benefits for both sides. The Paks Nuclear Power Plant, for example, is an actual demonstration of the practical, national-economic benefits which stem from this cooperation. In turn, your achievements in computer technology are also important to us. Hungarian computer technology is well-suited for the control of nuclear power plants. I am also personally satisfied with the results of this cooperation, and your academic leaders have expressed similar opinions on several occasions.

[Question] Do you see any possibility for developing multinational forms of cooperation? A Dubna-type institution, where scientists from the various socialist countries could work together, would be an excellent forum for socialist cooperation.

[Answer] Dubna is indeed an excellent institution, but I should remind you that it is not the only one of its kind in the Soviet Union where Soviet, Hungarian, East German and Bulgarian researchers and scientists from other socialist countries have been able to work together; I am thinking of Serpukhov, for example, where researchers from the fraternal countries have also been able to make use of the particle accelerator. There are also similar places in other branches of science.

[Question] Recently you were asked to answer some questions by an American weekly magazine. The correspondent asked you about the extent to which the American-imposed restrictions on American-Soviet cooperation has affected

the development of Soviet science. As I remember you replied that being compelled to rely on its own resources has also yielded some significant benefits for the Soviet Union in that it has been forced to develop several fields of its own science which otherwise would have faded away. I would expand the question this way: what advantages have resulted from socialist cooperation during the present perturbed period?

[Answer] The accomplishments of Soviet basic research are not bad. We wish, however, that they could be more rapidly put to practical use. This is always the basis I proceed from. It should be pointed out that our long years of undoubtedly very fruitful cooperation with the United States has caused many of our industrial leaders to become somewhat spoiled. They have been eager to buy ready-made technologies from the West which, using already available basic research data, could have been developed here at home at relatively low cost. Hence, due to a lack of incentives, over the years several important areas of research have faded away. Now, whether it wants it or not, industry is forced to rely more on our domestic accomplishments. This is certain to reduce the number of areas in which we presently lag behind. I feel that with the help of cooperation among the socialist countries we can overcome the difficulties brought on by the policy of embargo in any branch of science. This is true in nuclear technology, rocket technology and in many other areas of research which directly serve our industry and agriculture.

[Question] So far I have been questioning you. Allow me to in turn offer you my paper as a forum. Do you have anything to say, any message that you would like to address specifically to our readers?

[Answer] Yes, I do. Right now the circumstances facing mankind have immensely increased the role of science. The so-called traditional sources of energy are running out, hence it is up to science to find new resources. Nuclear energy is only one such resource. But similar shortages can also be found in natural raw and basic materials. And science does find solutions to these problems. Let us recall, for example, such seemingly incredible possibilities as the utilization of ceramic materials in machine production. Mankind also has a stake in the rapid development of food production, if we consider that some 40 million people around the world, mostly children, are dying of hunger and malnutrition. Adding to the problem is the fact that it is precisely some of the developing countries that are so very poor in energy and raw material sources and have such unfavorable food production conditions. Well, in order to alleviate these problems scientists from every country of the world should join forces. This should be done urgently and without delay. It is well known, however, that the world political situation has considerably restricted the possibilities of unselfish international scientific cooperation. Therefore, we must at least take advantage of the opportunities available to us in the socialist countries. I am convinced that we can accomplish a great deal together.

This, of course, is contingent upon our ability to prevent the outbreak of a worldwide thermonuclear catastrophe. But I believe in a better, unclouded message.

[Question] Thank you!

PLANS FOR PRODUCTION OF VARIETY OF INTEGRATED CIRCUITS ELABORATED

Budapest HETI VILAGGAZDASAG in Hungarian No 31, 30 Jul 83 pp 4-7

[Text] It is now over a year that the building of the Communications Technology Research Institute [Hiradastechnikai Kutatóintézet] located on Fóti út has been renamed and serves as headquarters of the Microelectronics Enterprise [MEV, Mikroelektronikai Vállalat]. The major assignment of the newly established enterprise is to produce in large series the integrated circuits urgently needed to upgrade the products of Hungarian equipment manufacturers within the framework of the government microelectronics program. We discussed the status of the MEV chip investment and what the enterprise is doing to familiarize customers with its product with Tamas Strausz, development director of MEV.

Question: When the Council of Ministers approved the central program for production of microelectronic parts in December 1981, it also decided to establish your enterprise. How was the MEV established and what is its most important task at present?

Answer: Our enterprise came into being last year through amalgamation of the Communications Technology Research Institute, the semiconductor fabricating section of United Incandescent and the semiconductor and machine factory of United Incandescent located in Gyongyos. The Gyongyos factory assembles and encapsulates ICs on the basis of a license purchased from the American Fairchild firm. At present, MEV employs 4,500 persons.

We consider establishment in two stages of an annual production capacity of 120,000 semiconductor slices within the frame of the government microelectronic program our most important task at present. During the first stage we must put into operation, with Soviet production equipment, a ship-producing plant which will make so-called MOS chips in 1984 and a chip plant using bipolar technology by 1985 each of which is to have an annual capacity of 60,000 chips. According to the program, we must produce 700,000 custom-made, equipment-oriented circuits by 1985. The remaining capacity must be used to fabricate 19 million mail order-type circuits for routine tasks as well as 135 million discrete semiconductors, chiefly transistors and diodes. Less than 2 billion forints are available for development, 30 percent of which is to come from the central development funds. The balance will be handled as an investment grant on the basis of an agreement with the State Development Bank.

Question: How far has the investments progressed? Doesn't the country's more difficult economic situation hamper acquisition of imported machinery?

Answer: Insofar as investments are concerned, the first stage is proceeding on schedule; import restrictions have had no lasting effect on the import of needed equipment. Since construction of the second chip plant is still in its initial stage, I can say nothing about the future time table. Although it is too soon to speak of a lag, there is already no leeway in the remainder of the program.

Question: The microelectronic program requires your undertaking to be economically sound. Will production of chips be profitable from the outset?

Answer: With its existing production capacity the MEV is making one billion forint's worth of semiconductors annually at present. When the new production lines and devices come on line in 1985, production must be increased by an additional billion forints. We plan to produce equipment oriented, custom-made circuits worth 320 million forints. The planned value of mail order circuits is to be 869 million forints. The latter will consist partly of processing our own chips and partly of processing chips purchased elsewhere. We will make discrete semiconductors worth the remaining 820 million forints. It is still early to predict our rentability precisely; however, preliminary calculations indicate that we will be self-supporting and can hold our ground. It is true that we will not be competitive pricewise with the capitalist producers of semiconductors, but our Hungarian customers won't have to pay much more for our products thanks to the price system and the import mechanism.

On the other hand, what is disturbing our sales and operating plans is the fact that domestic demand for ICs from Hungarian producers has not increased to the extent planned; consequently, we must sell more of our product abroad than initially intended. This places a great burden on EMO [Elektromodul Trade Enterprise] which is in charge of selling our products.

Question: Will EMO be able to find a market for the surplus? To my knowledge commerce in ICs in the socialist countries is currently hampered by the fact that the partners can offer only a limited selection and everyone is trying to obtain broader variety of types.

Answer: We are already buying and selling semiconductors worth several million rubles on the basis of bilateral intergovernmental agreements. However, our long term cooperation agreements motivate us to expand our trade. This is reenforced by the recent capitalist embargoes. The effort applies not only to the end product, chips, but to joint development of production equipment, commerce and cooperative production.

Question: Let us return to the domestic situation. The main objective of the microelectronics program is to improve the supply of parts and components for Hungarian-made equipment. Putting the products of a new enterprise on the market always requires time and careful market research. What are you doing to familiarize yourselves with customers' requirements, to win their confidence?

Answer: We are gathering data on requirements from the records of EMO and also consulting with the major producers of equipment. On the basis of this we plan to put 30 kinds of mail order circuits made of our own elements on the market in 1985; half of these are intended for socialist export. However, the major part of our effort will go into production of equipment-oriented, custom-made circuits. Production of these presupposes close links between producer and user. So far we have concluded contracts with 15 enterprises for delivery of circuits designed to their specifications. To provide this special service, MEV will evolve a computerized circuit designing apparatus which will allow engineers from consumer enterprises to participate in design work. We have also decided to place computer terminals suitable for designing circuits at the plants of major equipment producer and thereby promote joint creative activity.

Question: It seems that you are overstating the role of custom-made circuitry. Will it actually be worth it to the consumer to buy such circuits at greater cost at a time when circuitry functions are becoming increasingly all-purpose?

Answer: International experience indicates that it is worth it. Several semiconductor factories specialize exclusively in custom-made circuitry. We who have undertaken to meet part of domestic demand feel that we can provide a plus with custom-made circuits at the existing technological level. The advantage we offer is primarily technical. Its economic advantage shows up in the fact that our circuits are ultimately cheaper, including the cost of calibrating, installing and storing printed circuits. But it can also happen that there will be demand which will cost more to meet but is still a plus because the circuitry we design will make the equipment in which it is installed sell better.

Question: In the course of our conversation, you said that our ICs will not be competitive on Western markets. In this connection, I will pass on an unflattering opinion of an engineer user. He maintains that Hungarian producers of equipment will be at the mercy of MEV since MEV will have a monopoly on the Hungarian chip market resulting from government support. What is your opinion?

Answer: I consider this a great exaggeration; I feel that producers of some equipment are in a far greater monopoly position, and this can be proved easily in the shops. But leaving aside the economic consideration that a small country cannot afford to split production of highly capital-intensive micro-electronic equipment, let us note that Hungarian manufacturers of equipment and apparatus currently use 3,000 types of IC, and it is inconceivable that the number will fall below 1,500 even in the case of a stricter policy in regard to components. MEV will be able to produce 150-200 types annually. These also constitute repayment for products received from the CEMA countries. However, in addition to domestic production and shipments from the socialist countries, there will continue to be ECs which we will acquire from capitalist firms. So although MEV will be the sole producer of domestic semiconductors, it will provide only part of the selection available to domestic consumers.

Question: In the long run, the decisive question is how quickly electronic components production which is supposed to increase competitiveness of Hungarian apparatus manufacturing industry can overcome the decade-long lag.

Answer: When we worked out the details of the microelectronics program, our goal was to establish foundations for a technology attainable to us, one which would not put undue strain on the economy in its present state and which would, at the same time, satisfy the requirements of Hungarian producers of equipment and apparatus. We could not permit ourselves to aim for a peak product such as production of chips which crowd one million transistor functions a single 256 K-bit chip, because this would have required an investment at least 20 times greater than the present 1.9 billion forint investment. But what does a multi-decade lag actually mean? We have numerous products which are merely 2-3 years below the current state of the art. Furthermore, I think that with out equipment-oriented circuits produced by a technology capable of making 16 K bit chips which can perform 20,000 circuit functions we can soon reach the middle ground in the international semiconductor industry.

CSO: 2502/51

HUNGARY

BRIEFS

TELEPHONE FACTORY MAKES PERSONAL COMPUTERS--Production of personal computers has begun this year at the Telephone Factory in Budapest. Known as the TAP-34 terminal, the computer was developed by the Factory itself. The device can be used for data processing at banks, the railways, as well as at scientific and educational institutions. [Text] [Budapest NEPSZABADSAG in Hungarian 15 Jul 83 p 5]

CSO: 2502/49

PLANNER ASSESSES SCIENTIFIC RESEARCH DEVELOPMENT, APPLICATION

Warsaw TRYBUNA LUDU in Polish 20 May 83 p 4

[Interview with deputy chairman of the Planning Commission of the Council of Ministers, Jan Kuczma, by Tadeusz Belerski]

[Text] The development of technological progress and the practical application of scientific-technological ideas are, especially today, important issues having a vital influence on our exit from the crises. We have already broached this topic in the columns of TRYBUNA LUDU. A PAP reporter spoke on this topic with the deputy chairman of the Planning Commission of the Council of Ministers [RM], Jan Kuczma.

"The accomplishment of long range, as well as current, economic tasks, and the leading of the country out of the crisis demands improvements in efficient management and a distinct, lowered dependence on imports from the second payments area," J. Kuczma stated first of all. "Achieving these goals will not be possible without the application of technological ideas to a considerably broader degree than in the past. In the past years in Poland, we have benefited primarily from foreign technological ideas and also from the purchasing of licenses. We cannot afford this now. We must depend on ourselves to a greater degree and also broaden and improve cooperation in this area with socialist countries."

[Question] What kinds of changes are taking place in the system of guiding technology by research and development? What kind of role in this area falls to the Planning Commission of the Council?

[Answer] Scientific-technological work as well as the application and dissemination of its results should aid in the achieving of the goals and tasks designated in the National Socioeconomic Plan [NPSG]. The trends from this work will be brought into economic practice through the application of government orders as well as indirect influence, with the aid of appropriate mechanisms and stimulators on units of scientific-research subsidiaries, and production and service enterprises also. The concentration of means and the assurance of efficient accomplishment of especially the important scientific-technological solutions, as well as the tasks initiated by organizational units of science, are the aim of the government orders. The Council of Ministers will define the

operating principles for the application of government orders to the area of technological-economic progress as soon as possible. Subjects included in the orders will have priority before other tasks contained in plans for scientific and technological development. The main point here, above all, is the assurance of the essential means for their accomplishment.

It is particularly important to scientific work to make possible the covering of the operations costs from the research operations fund and the development of the central fund from the technological-economic operations, as well as make access to credit possible; and, if it will prove to be imperative, to assure them of preferential conditions for giving credit. They should be given the opportunity to profit from foreign-currency deductions from the claim of the export of goods, from scientific-technological achievements, as well as from the returns from conferences and scientific symposia. These funds could be reserved for an essential import for the management of research-development work through the solutions of scientific-technological implementors.

[Question] Will the initiation of government orders supersede the government programs and crucial issues?

[Answer] The government orders will determine a new form of initiating scientific-research and development and application work, which should be accomplished fully, from the concept to the manufacture. However, the introduction of government orders does not mean a departure from the forms of the organization of research-development tasks used in the past. The government research-development programs and crucial issues will continue to be carried out. By this, it does not mean that the number and sphere of the issues will remain unchanged. Included in the government orders will be those issues recognized by the government to be the most important from the point of view of economic needs. The NPSG for 1983-83 includes 104 scientific-research tasks; the total cost for executing the research-development work connected with the accomplishment of these tasks will amount to 15.8 billion zloty. The tentative cost of the application (in substance, after 1985) is estimated at 128 billion zloty. The objective effects resulting from putting these tasks into practice are well-defined with every assignment. Their financial results are estimated at about 270 billion zloty.

[Question] Which problems in the area of science and technology were recognized as being the most important in the NPSG for 1983-85?

[Answer] Accepted was the principle that, with the modest means which we will have at our disposal in the field of science and technology, the means will have to be concentrated on lines serving to meet the most urgent economic and social needs of the country. Accepted as these lines were the following:

Food, especially the development of insecticides, improvement in the technology and organization of storage, the introduction of new varieties of grain and agricultural products:

Housing construction, the safeguarding of health and the natural environment, and especially the development of the production of housing materials with better insulation and structural characteristics, the development of the technology and construction of single-family housing, the expansion of production of pharmaceuticals and drugs, the halting of the degradation of the natural environment through the construction of sewage treatment plants:

Economizing of raw and other materials, fuel and energy; in this, the development of the production of compression-ignition engines, automation systems, heat suppliers (regulators), new technology and design for generating thermal energy (fluidized bed furnaces), the production of new steel resistant to corrosion:

The export and expediting of import achieved through, among other things, the development of the production of new materials, technology, as well as machinery and fittings with universal parameters. Catalysts for the refining industry, for the desulphurization process, carriers and catalysts based on aluminum oxide, polycarbonate--a construction material; working out the technology of catalysts for the nitrogen flow-line or, ultimately, a new generation of pressure converters, for the chemistry and engineering industry, with microelectronic sensors.

[Question] What are the guarantees for accomplishing these programs under the conditions of the reformed economy?

[Answer] The government orders were closely interrelated with the principles accepted in the reform of the economy. They apply the stimulators in the undertaking of activities bringing profit to the enterprise. For research units, development units, and enterprises undertaking research topics and their initiation, it is proposed to apply a system of economic preferences for those operating efficiently. Their lure should additionally influence the growth of interest in technical progress, and even affect the appearance of competition in the scramble for achieving the assigned research-development tasks or the application tasks, as well. The principle in force in this will be: something for something.

Another form of certain guarantee is the creation, by the government, of a system allowing the realization of capital expenditures, which apply the results of scientific-research work of vital economic significance. They will be, as the possibilities arise, accomplished with the contribution of the means from their own initiating units. For example, the production of microprocessors, therapy and diagnostic devices for malignant tumors, the production of some insecticides, and the like, should be initiated this way. In the case of not meeting the obligations arising from the agreements to carry out the government orders, they have the use of analogous sanctions against those who were obligated by the government orders for materials and goods. Particular agreements can stipulate also other forms of responsibility for material aspects in not meeting the accepted obligations.

9891

CSO: 2602/26

RECENT SCIENTIFIC-TECHNICAL DEVELOPMENTS DESCRIBED

New Technical Progress Strategy

Krakow GAZETA KRAKOWSKA in Polish 29 Jun 83 pp 3, 4

[Article by Dr. (Eng.) Adam Peszko: "How Are We Implementing the New Strategy for Technological Progress?"]

[Text] The economic reform, the anti-inflation and savings program, export development and import management--all are synonymous with one basic notion: technological and organizational progress. Real sources of this progress today lie with the introduction into the units of the economy of the innovations developed by scientific and engineering organizations.

Taking stock of the science policy of the preceding decade and outlining the current tasks of science, the minister of science, higher education and technology, in his speech at the conference held in March 1982, stressed that in the system of planning and management of innovations more attention should be given to tying in the assignments of scientific and technological development with the current needs of producers. It is necessary to draw up a long-term program for scientific and technological development properly coordinated with the strategy for economic development that would provide for concentration (up to 1985) of recovering the industrial and agricultural level we had before the crisis. In 1986-90, we should proceed to reorient the structure of the economy toward enhancement of exports. This will be crucial for increasing the repayment of foreign debts, greater import capacity and ensuring our future position in the world market. An important factor in promoting innovation is the economic reform, which will force producers to continue their concern for technological development and improved quality of products, as well as improved processes and lower production costs.

The main form in which the tasks of scientific and technological progress are translated in the reform's framework are contracts for research, development and industrial implementation, based on direct contacts between and free choice of partners.

Ample occasion for evaluating the extent to which this new strategy has become the practice of Krakow city voivoidship was provided by the session of the Krakow PZPR Committee, which was facilitated by extensive probes and surveys of research and development institutes, design bureaus and enterprises. These studies found no tendency as yet towards a greater share of work based on bilateral contracts between economic units.

While in 1982 ministerial institutes in Krakow carried out (under direct requests from industry) 24 percent of their projects, and research and development centers and central laboratories 58 percent, in 1983 a drop of the share of institutes to 21 percent is envisaged. In research and development centers and central laboratories, a slight growth to 61 percent is expected. Therefore, a large share of centrally financed projects seems to be thus maintained, according to the survey data. Last year it was as high as 62 percent of the total projects performed by Krakow schools, institutes and R&D centers. For comparison, in industrialized nations an average of 70 percent of science potential is involved in projects under contract to industry.

In the face of these statistics, lack of interest on the part of our enterprises in using the results of centrally financed research is alarming. Of 26 industrial enterprises, 12 construction organizations and 13 design bureaus surveyed, only 3 (Lenin Metal Works, Kabel and Telpod) plan to use results of government-sponsored research in 1983. Do managers of Krakow construction organizations and design bureaus believe that they have attained the highest level of technical and organizational perfection and thus let others (weaker units) benefit from centralized research programs? Or do they have excessive funds and want themselves to order all the research they need from scientific organizations? Let us take a closer look at bilateral cooperation between science and industry. At the surveyed enterprises, the number of research projects performed under bilateral contracts in 1981, 1982 and 1983 was 85, 165 and 142, respectively; while spending was 65, 94 and 193 million zlotys. Cooperation grew at a slower pace in construction, where, in the same years, 10, 10 and 28 contracts were concluded at a cost of 6, 23 and 10 million zlotys. Design bureaus placed orders for research with R&D centers only sporadically, and that mostly for expert analyses. Despite the fact that projects under bilateral contract are effective and, on average, turn in a 1.5 zloty effect per 1 zloty cost, they still receive a small share in industrial financing. In 1983, R&D projects were allotted less than 0.4 percent of revenues in industry, 0.07 percent in construction and 0.5% by design bureaus.

On a larger time scale, R&D spending showed a tendency to decrease. From 1979 to 1983, relative research spending declined: while changed prices resulted in a 103 percent rise of total product value, research financing grew by just 10 percent, and subsidies from central fund in the meantime decreased by as much as 50 percent compared to baseline. Simultaneously,

innovators' activity was shrinking between 1979 and 1982, with an overall drop in the number of innovators' proposals in surveyed industrial enterprises of 64 percent, and in construction 86 percent. In construction, the economic effect of introduction of such innovations decreased (!) by a whopping 81 percent, while a 4 percent rise in obtained effects in industrial enterprises was equivalent to a relative decrease when adjusted for higher producer costs. These data give no grounds for optimism; and economic reform has not yet generated concern for technological progress nor a striving for improved quality and reduced costs through broader use of research and development results. To make things worse, local technological initiative of the staffs at enterprises is flagging.

In 1982, it was relatively easy to achieve a favorable financial result by raising the prices of products. A great number of enterprises took advantage of this, disregarding the repercussions for the national economy, such as exacerbated inflation. The national economy, however, has a limited amount of materials and semifinished products at its disposal, as well as limited energy capacities. In industrialized nations, during the 1950's, it was realized that the decisive factor of economic reform in this day and age is dissemination of knowledge and application of the results of scientific research, while capital accumulation and growth of employment constitute just the background for development. The use of scientific and technological ideas facilitates introduction of new products, efficiency of production processes and enhanced fulfillment of society's needs. New production methods save materials and are less energy-intensive. This provides opportunities for further production growth with the same material and energy base.

The high material- and energy-intensiveness of our economy stems from the low innovation ratio in industry. Our economic growth has been mainly based on accumulation, high levels of investment and purchases of foreign licenses, which were rarely truly innovative (and therefore not economical in terms of materials and energy), because such licenses are not usually for sale, as their holders prefer to use them for their production. The economic reform provided legal and organizational premises for unhindered utilization of scientific innovation in the shaping of enterprise growth.

Further improvement of the former mechanisms will result from linking the financial results of an enterprise with lowering of production costs. Even the most perfect economic and financial mechanisms, however, will be rendered ineffective if there is no change in the mind set of management and staff. The current resistance should be broken down, and there must be an openness to innovation based on research and development. This is confirmed by the experience of foreign nations, as well as by the practice of many Krakow factories (Lenin Metal Works, Kabel, Telpod, Krakow Measurement Instrumentation Factory, Fire Refractory Materials Works at Skawin, the chemical plant in Alwernia and the Kuznia Machine Tool Factory in Sulkowicy). The economic effect of projects introduced in 1982, and evaluated by surveyed enterprises as most efficient, was high; even in the first year it exceeded 5 zlotys per 1 zloty of investment.

The problem boils down to overcoming the ingrained habits and mastering by enterprise management of the skills to define assignments for research and development centers, and for using the results these provide. The other party's mentality, however, must also change. The nation's economic situation requires of all research and development centers greater openness to current economic problems. Despite appearances, these are not simple problems, and we should not fear that greater involvement in their solution may lower the level of Polish science. On the contrary, it will come closer to reality, and more young scientists will understand the root cause of the scientific success of such people as Professor Budryk and Professor Grzymek, whose anniversary has been celebrated recently.

Research and development centers should adopt a more aggressive approach in relation to industry. They must study the industry's needs, offer specific suggestions, widen the scope of information on concepts that are ready for implementation. The spread of scientific and technological progress should not be the concern of solely a narrow group of specialists and technologists. This is a general social process of a higher rank, and it requires the engagement of politicians in a substantial role in the day-to-day promotion of cooperation between research and development centers and units of the national economy. Party organizations, acting through promotion of innovative, creative and active attitudes among men and women of science and working people in all categories, and through providing the political and organizational conditions favoring introduction of new technical ideas, can greatly enhance this process. This has a bearing on personnel policy, selection of creative people for management positions and provisions for planned personnel rotation. Party organizations so far have given insufficient attention to these problems, and have not used effective methods to deal with the situation. These new forms of work should be created through promotion and maintenance of uninterrupted working contacts between party organizations of enterprises, design and technology bureaus, and research and development centers. Industrial enterprises should utilize more fully the capabilities of Scientific and Technological Associations NOT, units of the Polish Economic Society and the Society of Scientific Organizations and Management. Activists of these organizations can, for instance, prepare analyses for evaluation of the work of enterprise management for basic and higher level party organizations.

Optic-Fiber Technology, Production

Warsaw TRYBUNA LUDU in Polish 6 Jul 83 p 3

[Article by R. Wolak: "Light Used for Telephone Conversations: Optic Fibers from Lublin Available Soon"]

[Text] After three years of construction, the optic fiber factory in Lublin will soon be commissioned.

In the early days of July 1983, tests will be started of machinery and equipment that by the end of the year will produce the first optic fibers of the so-called first generation, with an outer diameter of 125 micrometers inner multilayer core 50 micrometers (on the average) in diameter, adapted for multiple telephone conversations over a dozen or so kilometers.

Optic-fibers and their production technology were developed several years ago at the physical chemistry enterprises of the UMCS in Lublin. Since 1979, a pilot optic-fiber telephone line has been in experimental operation in Lublin, the first such in a CEMA nation, connecting two telephone exchanges over a distance of 2.5 km.

Like a 6-km optic-fiber line built later in Lodz, it operates smoothly, although it is undergoing continual studies, changes and modifications. The work is being performed by the District Laboratory of Post and Telecommunications in Lublin, which is one of the investors in the optic-fiber producing plant, in close cooperation with the UMCS optic-fiber technology laboratory.

The fact that production of quartz optic-fiber cables has now attained an industrial scale does not mean, however, that the existing telephone lines will soon be replaced with voice transmission through cable by means of light, enabling simultaneous conduction of a dozen or so thousand conversations, immune to weather conditions and electromagnetic interference, and having smaller weight--and price-- than the existing copper cables. Years of research and testing will be needed before this happens.

The Lublin plant was created in an extraordinarily short period of time, considering the fact that it was started from design and construction of machines and equipment that did not exist in the country, rather than from the actual construction of the factory.

The assembly (three process lines) for optic-fiber cable production has been built at the Krakow Cable Machine Enterprises, based on documentation prepared jointly by the District Laboratory of Post and Telecommunications in Lublin, while equipment for production of the optic-fiber itself is made by the Lublin FSC, assisted by Swidnice WSK, and the control systems for fiber production were developed by Poznan Elektromontaz.

Airless Tire Production

Warsaw RZECZPOSPOLITA in Polish 23 Jun 83 p 4

[Article by (J.D.): "Airless Tires"]

[Text] The Metal Works Transport Equipment Enterprise at Czestochowa has no problems with tire supplies for slow-moving construction machines, because it has introduced an interesting technological solution not known earlier on a large scale. It is based on filling a tire volume with poly-

urethane foam instead of air. This largely increases the life of the tire and makes it resistant to the mechanical damage, so frequent at construction sites.

The new tires have been found to meet the specifications required of air-filled tires, while having a several times longer service life.

Developing new technical ideas, the enterprise works in cooperation with the Research and Development Center of the Tire Industry in Poznan, which manufactures the required equipment. In the next few months, a new production line is to be set in motion at Chestochowa. It will fill 6,000 tires with foam annually.

Parapsychology Movement

Gdansk GLOS WYBRZEZA in Polish 11 Mar 83 p 6

[Article by Jerzy Kubiak: "Useful Parapsychology"]

[Text] Parapsychology sounds mysterious. The Parapsychological Society recently formed in Szczecin, the first of its kind in the country, does not seek such a mysterious aura, though. Just the opposite. Its members insist that the goal of the organization (as stated in its charter) is to expand knowledge of all realms of parapsychology which may prove useful in practice. In many industrialized nations, a network of institutes are working on parapsychological studies.

The Pomeranian Parapsychology Society in Szczecin is comprised of six sections: astrology (headed by Leszek Szuman, who is a well known author of several books in the field, is popular in Poland and abroad, and is also chairman of the new society), divining, unconventional therapeutic methods, yoga and related methods of body improvement, psychotronics and the history of parapsychology.

The importance of some of these areas need not to be affirmed even to a layman. Divining has proved its usefulness in the search for water, oil, minerals and diagnosis of certain diseases. It helps determine, with great accuracy, sites that are harmful to human health, and is quite necessary and useful for spotting the places where one can work and rest most effectively. These studies could also be used to confirm sites for foundations of future factories--to ensure that they are not washed out by groundwater.

Acupuncture and bioenergetic therapy, which fall under the concern of the section for unconventional therapeutic methods, have also proved their practical utility. Suffice it to say that acupuncture clinics in Szczecin are frequented by an increasing number of patients--more than they can treat. They have also achieved good therapeutic results. Great interest was also aroused by the section on yoga and related methods of body awareness, which allow one to better relax and concentrate attention. Psychotronics, generally less well known, includes, among other

things, studies in telepathy, the possibilities of remote transmission of images and concepts.

The section on the history of parapsychology strives to study its history and development and disseminate relevant publications.

Finally, the astrology section will be concerned with publications, studies, etc.

With regard to intentions, it should be stressed that members of the Parapsychological Society resolutely dissociate themselves from all kinds of quackery and pseudoscientific research. They want to refine its usefulness in an enlightened scientific manner.

The creation of the Parapsychological Society in Szczecin has evoked lively interest. The conference hall, where the founding meeting was held, was filled to capacity. Members of different professions and people with different educational levels (from scientists involved in shipbuilding to doctors to economists to engineers and workers) attended in the hope of joining. The society decided to hold a series of conferences and seminars on such subjects as "Who Can be a Dowser?"; "Therapeutic Methods"; etc.

Whether parapsychology, as defined by the society (free of quackery and based on enlightened scientific research), can find its proper place remains to be seen. At any rate, the activity of the society deserves our attention.

Ocean Mineral Research

Warsaw KURIER POLSKI in Polish 31 May 83 p 1

[Article by (JB): "The Treasury of the Sea: Oil Found in the Baltic Sea at a Depth of 2500 m"]

[Text] Reserves of the four basic groups of raw materials--energy, metal, chemical and rocks--do not only occur in the earth's interior but also on the ocean floor. These are obviously reserves for the future, and their exploitation is envisaged after the year 2000.

Many teams have taken part in searches for "geological submarine treasures." Poles are no exception. For 10 years, they have been taking part in research in the Baltic Sea and the Atlantic Ocean, implementing the Intermorgeo program of the CEMA nations.

What is the object of these searches? Mainly, sources of energy--oil and gas. Nonferrous metal deposits are also being sought. In the Baltic Sea, in addition to crude oil (established at a depth of some 2500 m), deposits of silica sands and construction gravel have been found, which are already

being mined on a large scale from the so-called Slupsk bed. Lately, heavy minerals (such as zircon and ilmenite) have been found here, which may prove to have great industrial importance. The Baltic Sea may reveal more of its secrets to us as the research continues.

In the framework of the Intermorgeo program, our country takes part in the study of iron-manganese nodules in the Atlantic and Pacific. The results thus far indicate the occurrence of concentrated zones of these nodules, which in the remote future may be utilized because of their heightened content of iron and manganese, as well as other metals (such as copper, nickel and cobalt).

Research, consisting of several stages, is much more extensive than that carried out on land. It requires special types of equipment, instruments and installations for exploration, documentation and industrial exploitation.

At the latest session of Intermorgeo, it was decided that yearly international expeditions on research vessels will be organized, including the "Alexander Humboldt" and probably "Professor Siedlicki," as well as Soviet ships. The expeditions will be working in remote aquatoria of the Atlantic and Pacific.

END

9922
CSO: 2602/34