

R

059119

JPRS 82608

10 January 1983

19980909 127

West Europe Report

SCIENCE AND TECHNOLOGY

No. 133

DISTRIBUTION STATEMENT A
Approved for public release,
Distribution Unlimited

FBIS FOREIGN BROADCAST INFORMATION SERVICE

10
35
A03

NOTE

JPRS publications contain information primarily from foreign newspapers, periodicals and books, but also from news agency transmissions and broadcasts. Materials from foreign-language sources are translated; those from English-language sources are transcribed or reprinted, with the original phrasing and other characteristics retained.

Headlines, editorial reports, and material enclosed in brackets [] are supplied by JPRS. Processing indicators such as [Text] or [Excerpt] in the first line of each item, or following the last line of a brief, indicate how the original information was processed. Where no processing indicator is given, the information was summarized or extracted.

Unfamiliar names rendered phonetically or transliterated are enclosed in parentheses. Words or names preceded by a question mark and enclosed in parentheses were not clear in the original but have been supplied as appropriate in context. Other unattributed parenthetical notes within the body of an item originate with the source. Times within items are as given by source.

The contents of this publication in no way represent the policies, views or attitudes of the U.S. Government.

PROCUREMENT OF PUBLICATIONS

JPRS publications may be ordered from the National Technical Information Service, Springfield, Virginia 22161. In ordering, it is recommended that the JPRS number, title, date and author, if applicable, of publication be cited.

Current JPRS publications are announced in Government Reports Announcements issued semi-monthly by the National Technical Information Service, and are listed in the Monthly Catalog of U.S. Government Publications issued by the Superintendent of Documents, U.S. Government Printing Office, Washington, D.C. 20402.

Correspondence pertaining to matters other than procurement may be addressed to Joint Publications Research Service, 1000 North Glebe Road, Arlington, Virginia 22201.

WEST EUROPE REPORT
SCIENCE AND TECHNOLOGY

No. 133

CONTENTS

ENERGY

Combined-Cycle Power Plant Test Operation Successful (VDI NACHRICHTEN, 17 Sep 82).....	1
Low Quality Fuel Usable Interview With Project Head, Willy Meyer Interview	
Chemical Coal-Conversion Method May Be Economical (FRANKFURTER ZEITUNG/BLICK DURCH DIE WIRTSCHAFT, 8 Nov 82).....	7
Briefs	
Gasification Plans	9

SCIENCE POLICY

Briefs	
Research Ministry Budget	10

TRANSPORTATION

Italy Reluctant To Buy, Build Airbuses (Arnaud Rodier; LES ECHOS, 8 Nov 82).....	11
LPG, Hydrogen: Automobile Fuels of Tomorrow Discussed (LE MATIN, 11 Oct 82).....	13
Liquéfied Petroleum Gas, by Philippe Hazan Hydrogen Fuel, by Jacques Girardon	

ATR 42 Will Have Ultramodern, Innovative Cockpit, Avionics
(Serge Brosselin; AVIATION MAGAZINE INTERNATIONAL,
1 Nov 82)..... 19

Fiat Researchers Study Ceramics Applications in Diesels
(A. Giachello, et al.; ATA--INGEGNERIA AUTOMOTORISTICA,
Sep 82)..... 23

ENERGY

COMBINED-CYCLE POWER PLANT TEST OPERATION SUCCESSFUL

Low Quality Fuel Usable

Duesseldorf VDI NACHRICHTEN in German 17 Sep 82 p 5

[Text] In the presence of many notables, including Federal Research Minister Dr Andreas von Buelow and Saarland Minister President Werner Zeyer, on 26 August the Voelklingen model power plant of Saarberg AG was officially put into operation. The model character of this 230-MW hard-coal power plant manifested itself for one thing in the extensive measures taken for the protection of the environment, and secondly in a revolutionary thermodynamic linkage: On the one hand, fluidized-bed furnaces heat up air for a gas turbine, and on the other hand they help run a conventional steam generator. With that, for the first time coal with a very low calorific value is being made usable for the generation of electricity.

Crowded together on the power-plant premises by the Saar are three coal-fired power plants from three different generations. The two older ones, Fenne 2 and 3, loom menacingly with monotonous, blackened faces and enormous smokestacks, while the newest contrasts pleasantly with these, in having horizontally structured boiler house and power house done in brown and beige and with a light-colored cooling tower--but without a smokestack. At heights of 100 m and 90 m respectively, the cooling tower and boiler house cannot be inconspicuous, but other buildings of this type and size are certainly less "attractive."

The noise background which is familiar from other coal-fired power plants is completely lacking. The competent authority allows 37 decibels at neighboring residences. Therefore the outside walls of the boiler and power houses are soundproofed. And even the wet-type cooling tower, elsewhere a source of acoustic disturbances, is rigorously designed with an eye to the avoidance of noise. The water runs over corrugated packing without dripping, and whatever is generated nevertheless in the way of noises is suppressed by a soundproofing wall all around the tower.

But the fact that the cooling stack is placed around the periphery at the base and therefore the cooling tower is of the cross-flow natural draft type is the result of space considerations. That is, the interior contains the stack-gas desulfurization system, or REA for short. In the prevailing "pea-soup fog," the upper surface of this structure, which is almost 40 m above the floor, can scarcely even be discerned. The REA operates according to the Saarberg-Hoelter process. This wet process using milk of lime was applied previously at the Weiher III power plant near Saarbruecken on a portion of the stack gas, and it has been developed to such an extent there that here at the model power plant

they are venturing for the first time to treat the entire stack gas by this process. At full load, this amounts to 770,000 m³/h, for which 1 ton of lime must be used and 3 tons of gypsum must be "disposed of." A minimum separation efficiency of 80 percent for SO₂, fluorine, and HCl has been stipulated. With respect to SO₂, this means a maximum content of 547 mg/m³ of cleaned gas. An amount less than 500 mg/m³ is being achieved.

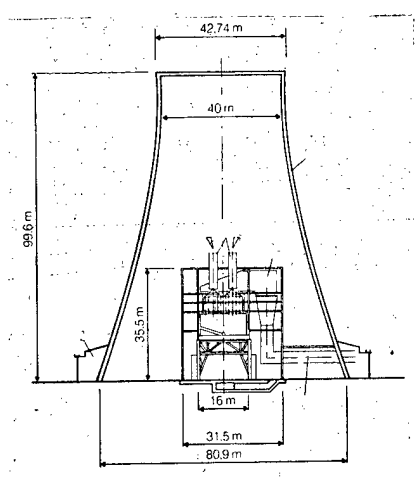

Figure 1: The cooling tower contains the stack-gas desulfurization system. The following are designated: Cooling-tower shell (1), cross-flow cooling fill (2), stack-gas desulfurization system (3), crude-gas inlet (4), cleaned-gas stacks (5).

The incorporation of the REA within the cooling tower produces the advantage that the contaminants which are unavoidably contained in the cleaned gas are distributed better into the environment than would be possible by way of a tall stack.

When one steps into the boiler house, he sees familiar things next to unfamiliar ones. The things that are familiar--in a hard-coal power plant--are the mills, elevators, and bunkers for the coal dust as well as the conventional steam generator. On the other hand, what is new--and never before seen in a power plant--are two coal-fired fluidized-bed furnaces (each 11 m in outside diameter and 13 m in height) and their connection with the steam generator and a gas turbine. To be sure, the latter is found also in combined-cycle power plants. But whereas in those plants it operates on gas or oil, in the model power plant it derives the bulk of its heat energy from the fluidized-bed furnaces and thus from the solid fuel of coal.

This technology is based on a farsighted consideration. Graduate Engineer Willy Meyer, initiator and project head of the model power plant (see also article below) had been pursuing for a long time all those investigations which were concerned with whether and how low-grade waste coal could be used in an economical way for the generation of energy. Indeed, in many countries there are enormous quantities of energy in the form of waste coal lying unused on the waste heap or in the ground. But all the studies came to the conclusion that--with the conventional technology--it was not worthwhile to dig up these resources: Because of the high inerts content of such coal, its calorific value is too low to permit those temperatures to be achieved which are necessary for the generation of high-pressure steam. 2

Waste Coal Available Worldwide

Now Meyer's idea was to use waste coal not to generate steam but to heat air in a fluidized-bed furnace and with this hot air to drive a turbine with generators. Then the exhaust air of the turbine was to flow as combustion air both into the fluidized-bed furnace and also into a conventional steam generator. The greatest hurdle in the way of putting this idea into practice was obviously the coal fluidized-bed furnace, because it did not exist in the requisite size even for the heating of air.

One thing was clear: Since the heat transfer from the fire to the air--which is performed via corrosion-resistant pipes in the fluidized bed--is much worse than when using the customary medium of water, the pipe surface area had to be made considerably larger. But there were no experiences at hand concerning such a large immersion heating surface. Thus a test facility was built (at the neighboring power plant of Fenne 3 and for more than DM 1 million) with a grate area of 3 m² and a fluidized-bed height of 2 m. It was started up in 1980, and in 7,000 hours of operation it provided findings which found expression in the two furnaces of the model power plant: For each unit, 2,400 nozzles supply a good volume of combustion air (on a grate area of almost 80 m²), the area of the immersion heating surface comes to 1,360 m², the fluidized bed is 1.8 m high in the quiescent condition and 2.2 m high in the fluidized state, and the "belt charging" with coal (and limestone) is done from above. Some 60 percent of the sulfur (more with the addition of limestone) is retained in the ash.

On the day that it opened, the power plant already was running with an output of 100 MW. The fluidized-bed system was not yet quite finished, but it should be completed by the end of 1982. Then the system will function as follows: The compressor of the gas turbine draws in outside air and compresses it to 6.4 bars, causing it to rise to a temperature of 280°C. This air is now heated at the immersion heating surfaces of the fluidized-bed furnaces to about 700°C, and--in a path concentric with the feed-in--it is brought to the combustion chamber of the gas turbine. Here it reaches 820°C through the combustion of gas and is allowed to expand in the turbine. The output of the gas turbo-generator is 32.3 MW. The turbine off-gases serve further as a combustion air for the fluidized-bed furnaces and for the steam generator, and there remains even enough for in-the-mill drying of the coal dust.

The combustion gases of the fluidized-bed furnaces, which are at a temperature of 900°C, are also used a second time by being introduced into the firebox of the steam generator. There they contribute 20 percent of the energy needed for the steam generation. The output of the steam turbo-generator set is 195 MW (with live steam at 190 bars and 335°C). There are plans to draw off a maximum of 130 Gcal of steam per hour from the steam turbine for the Saar district-heating transmission line. The reduced electric output would amount to 26 MW, but the overall efficiency of the power plant would rise from 38.5 percent (without a draw-off for district heating) to 62 percent.

The capital-expenditure costs are estimated at DM 550 million (of which the Federal Ministry for Research and Technology (BMFT) will contribute about a third within the framework of the competition "The Environmentally Compatible

Coal-fired Power Plant"). At 13 to 14 pfennigs per kilowatt-hour, the electricity cost price will be close to a normal level for coal-fired power plants. The Voelklingen model power plant is a masterful linking of electric-power plant, namely the conventional portion of the system, and a test facility--the fluidized-bed furnaces with the gas turbine. People will be looking forward to seeing whether and to what extent the model power plant will gain acceptance. Actually there are two models in one here--the first involving environmental protection in connection with coal-fired power plants, the other involving the utilization of otherwise unusable waste coal.

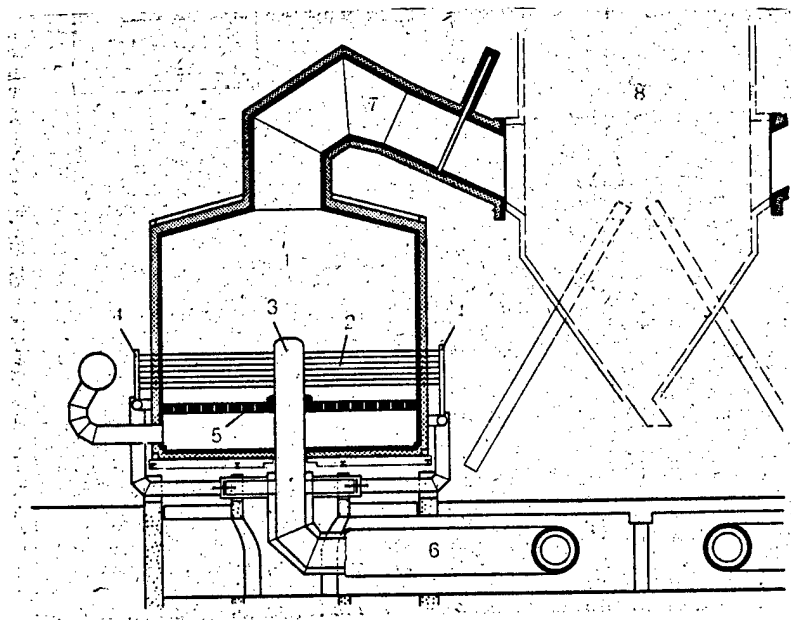

Figure 2: The fluidized-bed furnace, consisting of: Fluidized-bed combustion chamber (1), immersion heating surface (2), inner header (3), outer header (4), nozzle bottom (5), coaxial line (6), off-gas channel (7), and steam generator (8).

Interview with Project Head

Duesseldorf VDI NACHRICHTEN in German 17 Sep 82 p 2

[Interview with Graduate Engineer Willy Meyer, managing director of Saarberg-Interplan, by Rudolf Weber]

[Text] The hard-coal power plant of Saarberg AG, which officially went into operation on 26 August (see above report) will be the first in the world using a combined-cycle operation run exclusively on a solid-fuel basis. The technology being applied here gives hopes of making accessible a previously uneconomical and therefore unused energy source--that is, low-grade coal with a low calorific

value. VDI NACHRICHTEN spoke with the initiator and project head of the model power plant, Graduate Engineer Willy Meyer, managing director of the Saarberg subsidiary Saarberg-Interplan.

VDI NACHRICHTEN: Mr Meyer, first a compliment for the outward appearance of the model power plant. The brown tones and the absence of a smokestack make it seem as well fitted into the surroundings as it can ever be with such a structure.

Meyer: Many thanks, but I must also pass on the compliment to the responsible town council, which played a prominent part in creating the design.

VDI NACHRICHTEN: But you would not demur to being described as the father of this model power plant?

Meyer: As long as I do not have to pay any child support for this, no.

VDI NACHRICHTEN: Then how and when was the idea for this born, especially with respect to the combination of fluidized-bed furnace, gas turbine, and conventional coal boiler?

Meyer: The initial conceptions occurred to us around 1970. In the following years, the individual components took shape in our minds, and in 1977 the power plant existed as a dream. That is, we knew that it was technically feasible. But at first nobody dared to think about its realization.

VDI NACHRICHTEN: And how then did the construction come about after all?

Meyer: Soon after the "dream" came into being, the Federal Ministry for Research and Technology (BMFT) announced the competition of ideas entitled "The Environmentally Compatible Hard-coal Power Plant." We took part, and our proposal was subjected to feasibility studies by three independent groups, the outcome being that it was not only feasible, but also attractive.

VDI NACHRICHTEN: And as one learns from the BMFT, your proposal was also far the best, so that a construction subsidy was granted. Did this subsidy give the starting signal?

Meyer: Yes, because after all it makes up a third of the construction costs, which finally reached DM 550 million.

VDI NACHRICHTEN: With the laying of the foundation stone in March 1980 and the initial startup in August 1982, the construction really has made speedy progress. What has been accomplished with the initial startup, and how is the program of the near future shaping up?

Meyer: In fact, the fluidized-bed furnaces are not quite finished as yet. Our goal is to put them and the gas turbine in operation by the end of 1982. Then this will be the first combined-cycle operation in the world which is run exclusively on a solid-fuel basis. Subsequent to that, we will run through what I like to call the "innovative operation"--the possibilities both of the overall process and also of the individual components. An extreme example of the latter is to run the conventional boiler as an off-gas boiler of the fluidized-bed facility.

VDI NACHRICHTEN: How long is this testing phase to last?

Meyer: Probably until 1985. However, based on the experiences which we have gained by the construction, even now concrete projects for new facilities are appearing on the horizon. For one such project, the decision has even been taken already, in fact in one of our neighboring countries. There, a unit is being designed in such a way with respect to output and generation capabilities that it just uses up the material in the pit heaps existing in the area in the course of the plant's total useful life.

VDI NACHRICHTEN: With the possibility of burning dirty coal with a low calorific value in the fluidized-bed furnaces, is not a previously unused source of energy being made accessible?

Meyer: One can say that as well. Our tests with a small furnace model have shown that the very poorest-grade coal and even automobile tires can burn in the fluidized bed. Such low-grade fuels and especially pit heaps have remained unexploited hitherto as sources of energy in many countries. With a technology based on this model power plant, these waste heaps could be used for the generation of electricity and heat. Thus we have had inquiries already about this from Australia, America, and Asia.

12114

CSO: 3698/116

ENERGY

CHEMICAL COAL-CONVERSION METHOD MAY BE ECONOMICAL

Frankfurt/Main FRANKFURTER ZEITUNG/BLICK DURCH DIE WIRTSCHAFT in German 8 Nov 82 p 7

[Article: "Coal Gasoline Could Still Pay Off"]

[Text] A. L. Alkali-Hydrid BmbH, Wuppertal. At a coal price of DM 160 to 180 per ton and an electrical energy cost of between DM 0.07 and 0.10 per kWh, the firm considers the production of gasoline or diesel oil from coal to be worth thinking about. Although conventional coal gasification--even with considerable monetary support--has proven to be uneconomical, Alkali-Hydrid believes it has in its process for chemical conversion of coal into liquid hydrocarbons a promising starting point toward reducing dependence on oil imports.

In particular, the company has to say in this regard: "The erroneous assumption appears to be in the starting point since until now only processes have been considered in which coal is gasified by combustion and thus requires about 4.5 kg of coal--3.1 kg in the most favorable case--for the production of 1 kg of liquid hydrocarbons like gasoline or diesel oil; whereas, through pure chemical conversion following the Alkali-Hydrid process, only 1.9 kg of coal is needed. The method can also process soft lignite or plant products like wood and straw. With soft lignite 2.2 kg and with plant products 3.2 kg is required per kg of gasoline or similar hydrocarbon. In view of these data, coal is much too valuable to simply be burned.

The investment cost for the production of 1 ton of gasoline or diesel oil per hour is about DM 8 million with the Alkali-Hydrid process. In the past, facilities using conventional combustion processes with 25 times this output and costs in the billions have been discussed. On the basis of an economic feasibility study, Alkali-Hydrid figures that with their process a gasoline sales price of DM 1.425 per liter, including 13 percent value-added tax, will be required. The fixed cost for amortization, interest, insurance, management, repairs, service and personnel will amount to about 14 percent. Processing, sales, transportation and storage costs amount to about 17 percent. The remainder of about 56 percent is variable and today depends on realistic potential coal and electricity prices.

According to the company, the preceeding figures can be realized if coal and electricity are available at the quoted prices. Alkali-Hydrid figures, in addition, that through the construction of the associated facilities employment will be provided for the machine building industry, favored among other things by the export of such facilities. In addition, the firm's process makes it possible to recover uranium from coal residues.

9160

CSO: 3698/86

ENERGY

BRIEFS

GASIFICATION PLANS--A cooperative agreement on surface coal gasification and the treatment of the gas produced has just been signed by the three nationalized firms French Coal Company, EDF [French Electricity Company] and GDF [French Gas Company]. This cooperation, which covers all the processes likely to be studied, whether energy-autonomous or not, specifically applies to the research and development effort involving pilot or demonstration units whose high cost and long development periods require a joint effort. Considering the objectives of the partners, which more specifically apply to the production of gas or hydrogen for chemical syntheses, the use of electricity generating units (gas turbines, motors, boilers), the production of industrial gas for heating purposes, or of gas to substitute for natural gas, the cooperation will involve basically the following areas: gasification of coal by oxygen-steam mixture (oxyvapogasification), applying new processes that can use a broad range of coals, as well as the secondary products from the preparation of coal and, ultimately, of other residue; purification and treatment of the gasification gases; optimal chemical and energy development of the gases from gasification; and liquefaction and gasification by hydrogenation that could supply GNS [Synthetic Natural Gas] and fuels. [Text] [Paris SEMAINE DE L'ENERGIE in French 17 Oct. 82 p 10] 9969

CSO: 3698/66

SCIENCE POLICY

BRIEFS

RESEARCH MINISTRY BUDGET--The proposed Federal Budget for fiscal year 1983 provides in detail plan 30 for the business area of the Federal Ministry for Research and Technology (BMFT) a total outlay of DM 7.062 billion (all figures rounded in the last place) which is 7.3 percent more than appropriated for 1982. The following amounts are provided for the categories listed: DM 2.738 billion for energy research and technology; DM 373.5 million for raw material stock-piling and material development; DM 184.9 for marine research and technology; DM 38.6 million for innovation support; DM 82.0 million for physical technologies and manufacturing technology; DM 299.7 million for electronics; DM 56.6 million for data processing; DM 920.2 million for space research and technology; DM 80.7 million for aeronautical research and technology; DM 499.0 million for health, nutrition and environments; DM 118.0 million for humanization of work life; DM 263.5 million for transportation and traffic technologies plus construction research; DM 166.3 million for technical communications and information technology; DM 72.6 million for information and documentation; DM 575.9 million for general research support; DM 624.1 million for basic research in physical chemistry (various amounts for basic research are contained in the other support areas) and DM 48.4 million for administration. [Excerpt] [Duesseldorf ATOMWIRTSCHAFT-ATOMTECHNIK in German Nov 82 p 590] 9160

CSO: 3698/86

TRANSPORTATION

ITALY RELUCTANT TO BUY, BUILD AIRBUSES

Paris LES ECHOS in French 8 Nov 82 p 7

[Article by Arnaud Rodier: "Italy Making Life Difficult for Airbus Industrie"]

[Text] Italy prefers the United States to Europe while the latter only has eyes for Italy. Airbus Industrie betrayed at the very moment the consortium is proposing that Aeritalia work with it and is offering a 15-percent share in the A-320 program. Bernard Lathiere, managing director of Airbus Industrie, who just a few days ago was in the United States, must be fuming. He is the one who maintained that Alitalia remained one of the rare large markets open to the Airbus A-320 in the coming 2 years and he did not see it coming.

But the health of airline companies is such that planes can no longer be sold like any other product. You have to lower prices drastically, make attractive financing proposals, put up complicated side offers. Alitalia's decision to take an option on 30 Super-80 DC-9's built by McDonnell-Douglas to renew its fleet perfectly illustrates two things: the dumping war that all the manufacturers are engaged in and the importance of bonds that traditionally unite a client nation to a selling nation.

To sell its planes, McDonnell Douglas first proposes to Italy a lower price than that of the international market. A DC-9 costs a little over \$22 million, but Alitalia will not pay that price. Then, the American manufacturer is also promising to take not only the company's old DC-9's but also the Boeing-727's that it no longer wants to operate. The European consortium had also made specific proposals to Alitalia by offering it a contract including, with the sale of the Airbus A-310 [sic], taking back the company's old DC-9's. But that was forgetting that Italy has long had privileged relationships with the United States.

For Airbus, the disappointment is all the greater because the selection of the DC-9 80 sinks the chances of the A-320 in Italy. However, Bernard Lathiere never hoped to chase his American rivals from the Italian market. "We want to persuade Italy that it would be good to buy four or five Airbuses while ordering other planes on the side," comments the boss of the European consortium. A process similar to that of Airbus Industrie when it proposes that Aeritalia, the aircraft manufacturer, participate in the building of the A-320.

"The broadening of Airbus Industrie will give us a firmer footing and, since neither Alitalia nor Fokker can launch a plane all alone, with whom will they go?" asks Bernard Lathiere. And adds, "To varying degrees, all of the countries of Europe are working on the Airbuses except Italy. However, we are not asking them to drop the United States." Diplomatic language, and reasonable language, too. However, Rome still needs a lot of persuading. And if the government is taking so long to respond to the Europeans, it is obviously because American pressure is very strong.

The selection of McDonnell-Douglas by Alitalia is a serious warning for Airbus. But it is not yet a failure, especially since the final decision is subject to the approval of the Italian authorities.

There remains the fact that Italy's attitude, during this period of aeronautical crisis proves that the smallest customer can be important. And that it is not enough to be European to be Airbus Industrie customer. For the European group, that is truly a lesson.

9969

CSO: 3698/66

TRANSPORTATION

LPG, HYDROGEN: AUTOMOBILE FUELS OF TOMORROW DISCUSSED

Liquefied Petroleum Gas

Paris LE MATIN in French 11 Oct 82 pp 18-19

[Article by Philippe Hazan]

[Text] In Italy, 450,000 cars are running on liquefied gas. This is now becoming a fashion in France. In the United States, researchers may have succeeded in lowering the cost of hydrogen, which will perhaps be the fuel of the third millenium.

Will hydrogen one day supplant petroleum, its derivatives and substitutes, thus once and for all brushing aside the frightening threat of a shortage? Most everywhere in the world, teams of researchers are making an effort to overcome the use of this inexhaustible fuel. A recent report written by scientists of the Batelle Institute in Geneva, discussing this research, shows that these difficulties are far from being overcome. In the United States, the advanced studies division at Ford, associated with the NASA and with the aeronautical motor specialist Garrett Air Research, which has been working in this direction since 1979, has failed for the time being. Nevertheless, at the University of Texas, the American petroleum kingdom, the team at College Station has perhaps taken one step forward. By using solar energy, it may have succeeded, using the electrolysis of water, in substantially lowering the cost of production of hydrogen fuel. When asked about this result, the consulting offices of French constructors are, as far as they are concerned, extremely skeptical. None of them expect to see any major mode of combustion other than gasoline by the year 2000. And researchers at Ford themselves do not hope to obtain concrete results before that date. Finally, specialists at PSA and the Regie Renault estimate that the use of hydrogen--which comprises enormous technical constraints--would require the radical modification of the internal structure of motors.

While waiting for the third millenium, a beginning in the displacement of gasoline can be seen, due, in particular, to liquefied petroleum gas or LPG. Since 1979, when the government--through the Agency for Economy of Energy--has allowed its use as an automobile fuel, LPG has gathered followers: approximately 22,500 private cars are presently using this new source of energy in France. LPG has also made a thrust in Japan. And, as far as our neighbors are

concerned, Italy is the country in which this system has become most widespread: last year, there were 450,000 private cars running on LPG. LE MATIN explains the reasons for this success.

The Advantages of the LPG System: Economy and Reliability

It can save up to 45 percent of the fuel budget and extend the life of the motor.

Three years after the introduction of LPG (liquefied petroleum gas) in France, it is time to focus on this "fashion" which is slowly but surely developing. In comparison with gasoline combustion, LPG has a certain number of advantages: a lower noise level, greater motor longevity, but especially an economy of approximately 45 percent for the fuel budget alone, provided at least 45,000 km are covered per year. But two drawbacks are also to be considered: the cost of installation (between Fr 4,000 and 6,000) and the scattering of supply stations; however, this factor seems to be improving. Unfortunately, the fiscal advantage granted in France to LPG does not compensate for the prohibition of double combustion which makes it possible to use either gas or gasoline, both systems being present in the same vehicle.

However, there is an encouraging sign: imitating their American, Italian and Japanese counterparts, certain insurance companies have lowered their rates by 20 percent on the basis of the fact (demonstrated technically) that a car running on LPG is, in case of accident, potentially less dangerous than its gasoline equivalent.

To drive on gas, in France, was something difficult to visualize as recently as 2 years ago. Technically, the different systems for feeding the carburetor were not sufficiently reliable. Furthermore, there were no more than approximately 20 LPG supply stations, the majority of which were distributed around Paris. Finally the gasoline-gas parity was not in the latter's favor. In conclusion, it was less economical at the time to drive on gasoline than on LPG.

Today, things have changed considerably. Provided a minimum of 35,000 km per year are covered, LPG, in spite of its specificity--and the fact that it is imperative to choose between gas and gasoline, mixing being forbidden in France in order to limit demand--liquefied petroleum gas becomes a very valid solution. It may even be said that it is directly competitive with diesel.

Indeed, LPG is cheaper than gas oil (Fr 2.80 per liter as opposed to 3.55 for gas oil, Fr 4.38 for gasoline and Fr 4.69 for super). Adapting of a conversion kit costs from Fr 4,000 to 6,000, depending on whether this adaptation is made when a new car is ordered or on a used model. With regard to the competition between diesel and LPG, it can easily be explained by taking a specific example. A 505 GL equipped with the LPG system costs today Fr 61,000. The same model as a diesel version is marketed at Fr 64,000. This corresponds to a difference of Fr 3,000 in favor of the "gas car." Since it is known, on the other hand, that a liter of gas oil is more expensive than a liter of LPG, that diesel pollutes and that the performances of a model running on gas are

practically the same as those of its gasoline equivalent, whereas when diesel is used (in spite of progress accomplished in the past 2 years by motorists) they decrease by approximately 20 percent, the solution therefore seems to be clear: let us all drive with LPG!

As a matter of fact, all is not as simple as it appears. First of all, the supply problem has to be dealt with. There are in France, at present, 800 service stations which are specially equipped and this number will increase to 1,500 in 1983. There are approximately 50 in and around Paris but only 3 in the Hautes-Alpes, 2 in Corsica and a single 1 in the Meuse! The distribution of stations is far from being satisfactory at the present time. Furthermore, a liquefied gas tank can range in volume from 43 to 150 liters but, in all cases, it takes up a certain amount of space in the trunk of a private car. This corresponds somewhat to having with you one or more large suitcases. Finally, the use of LPG in a used car requires the drawing up of a specific registration card after presentation to the Mines Department.

It is nonetheless true that, with regard to the advantages, in addition to those mentioned above, LPG cancels the dilution of gasoline in oil and therefore considerably spaces drains, providing a saving for the motor in the proportion of 40 percent since the latter is subjected to smaller thermal constraints.

As regards the resale value of such a vehicle, it is to be compared with that of a diesel car.

Besides the Italians, who were the European precursors of this type of system as early as 1977, Japan, the United States, Belgium and the Netherlands are the most assiduous users of LPG. All these countries had the intelligent idea to accept the gasoline-gas combination, which makes it possible for a driver, using a simple handle, to change the supply mode while driving.

A very important last point: LPG is not dangerous in case of accidents and presents no explosion hazards. Indeed, this is a petroleum by-product consisting of saturated hydrocarbons (butane and propane) associated in unequal proportions and bears no relationship to what is commonly termed natural gas. Furthermore, all LPG equipment is mounted in a safety case which prevents leaks in case of shattering. Because of the use of self-closing valves (of the same type as those used on formula 1 tanks) all pipes are automatically closed, which thus avoids leaks of liquid gas. This system has especially proved its value when a vehicle has overturned.

These factors are probably the reason why insurance companies such as the Drouot group or the Mutuelles du Mans are lowering the amount of their premium by 20 percent for a vehicle operating on LPG. It is true that in Italy, this value can be as high as 40 percent....

Comparative Performances of Gasoline-Gas-Diesel

Vehicle: Peugeot 504 GR, 8,000 km (Montlhery speed ring)

	<u>400 m</u>	<u>1,000 m</u>	<u>Maximum speed km/h</u>
Gasoline	19"12	37"56	156,789
Gas	19"89	38"08	158.109
Diesel	22"42	41"04	136.109

The Italian Example

[Boxed insert by P.H.]

Of all the European countries, Italy is by far the one which has the largest number of cars running on LPG. This phenomenon developed in 1977 in that country, and today there are 450,000 private cars running on LPG. It is estimated that this number will increase to 600,000 by the end of 1983.

The tremendous difference between French and Italian legislation lies in the possibility for the user to have available in his car two supply systems: gasoline and gas. A simple handle is actuated on the dashboard to switch from one to the other. LPG is substantially more flexible in the city at a low engine speed but gasoline offers a better pick-up and more sustained acceleration on the road. The compromise is therefore ideal for the Italian motorist.

Furthermore, there are 4,800 supply points and the price of a liter of LPG is 47 percent lower than that of super whereas, in France, this difference is only 34 percent. All Italian constructors and the majority of importers propose versions in their catalogue which are equipped with LPG and a complete installation costs approximately 800,000 liras (Fr 4,000). Finally, it should be specified that part of the LPG equipment marketed in France is manufactured in Italy by OMT Tartarini; this company exports, in addition, a quarter of its production to Japan where almost 500,000 cars are being driven on this system.

All countries using LPG authorize alternate operation with gasoline except France. This is probably due to the concern of government authorities as regards the maintenance of gas consumption (butane and propane) for automobile use at extremely reasonable levels, petroleum gases representing only 3.5 percent of refinery production.

Hydrogen Fuel

Paris LE MATIN in French 11 Oct 82 p 19

[Article by Jacques Girardon]

[Text] The objective of research workers is to first lower production costs of what will undoubtedly be the energy of the future.

Hydrogen is the energy of tomorrow. The only real obstacle to its massive use is, at present, the cost of its production. A team in Texas has just developed a new ingenious method to extract hydrogen from water which might lower the costs. But we are still far away today from the all-hydrogen era.

The "must" of fuels, the one which supplies the combustion needs of the sun and stars, which gives its power to the most terrible of bombs, hydrogen, is alas the most abundant element in the universe. If this fabulous energy potential is not widely used, it is because its small atoms--consisting of a single electron gravitating around a single proton--are difficult to tame. Turbulent because of its volatility--it is the lightest of all substances--"inflammable air," as the alchemists called it, boils at -253°C . To use it in liquid form is therefore not a sinecure. Engineers at the National Center for Space Research have recently had this bitter experience with the third stage of the Ariane rocket....

But difficult does not mean impossible. Proof: Ariane has already flown without any incident, and is it not true that the Americans are presently mastering the use of liquid hydrogen as a rocket fuel? Everywhere in the world, research is being carried out on this energy source of the third millenium. Advances are real even if they are less spectacular than some might wish to have people believe: the hydrogen car is not for the next Automobile Show, but some day it will exist. Tens of thousands of vehicles are already using methane. Switching over to hydrogen would not amount to a revolution.

However, two obstacles must still be overcome:

--Storage: either extremely large or much heavier tanks would be necessary if hydrogen is to be transported under pressure. But it should be possible to solve this problem through the use of certain hydrides (combinations of H_2 with alkali metals) which contain, for equal volumes, much more hydrogen than the pure gas, even under pressure.

--Production cost: this is the major problem. Hydrogen can be produced using several processes: "steamforming" [in English] which consists in projecting a mixture of hydrocarbons and superheated water vapor onto a catalyst. But the price of the gas thus obtained is increased by that of the hydrocarbons and heat: too expensive. It might be possible to dissociate water directly using heat. But the reaction occurs only at $2,500^{\circ}\text{C}$! Eliminated. The electrolysis of water still remains as a possibility: here again, electricity is necessary to start with. In all cases, it is the same vicious cycle: in order to produce hydrogen, large quantities of that very same energy which hydrogen is supposed to replace are consumed.

The method just developed by researchers at the University of Texas, at College Station, is rather intriguing: it consists in using solar collectors to effect the electrolysis (i.e., the electrochemical separation) of water using a low electrical intensity. The results obtained for the last 3 weeks are encouraging and Dr John Brockris, who heads this research, believes that within 6 months

the efficiency of the method will make it possible to exceed the 20 percent of usable hydrogen presently obtained. He estimates that the gas which he produces according to his process might be sold for \$1 per gallon (3.78 l).

It is clear that if the cost of production of hydrogen might be substantially lowered, things might move very quickly: this gas is easy to transport--"hydrogen pipelines already exist and a 204 km network is even operating in the Ruhr. It is nonpolluting--which might make it possible for cities to become breathable again. Finally, it is not very dangerous: a concentration of 4 percent is necessary for it to ignite, whereas 1 percent is enough for butane. Furthermore, its extreme lightness causes it to disperse very quickly in case of a leak.

Hydrogen could replace not only gasoline but also city gas--the burners of gas ranges would simply be replaced. It could supply electric, thermal or thermonuclear power stations. It could be used as a fuel for airplanes. This might be difficult but NASA is studying the question.

The era of all-hydrogen will undoubtedly come. When? Since the obstacles are more economical than technological, we will switch over to hydrogen only when petroleum becomes really too expensive.

How Much Does an LPG Installation Cost?

[Boxed insert by P.H.]

Peugeot: 505 GL (Fr 6,000)

French constructors have available options listed in catalogues which exempt the user from dealing with the Department of Mines. On the other hand, this formality is indispensable when mounting a foreign kit.

Price of adaptations:

Peugeot: 505 GL (Fr 6,000)
--504 GR (Fr 6,000) - 305 (Fr 5,700).

Citroen: 2 CV Acadiane (Fr 4,850)--LNA (Fr 54,940)--GSA (Fr 5,050)--
CX 20 and 20 TRE (ex-Reflex and Athena) (Fr 4,800).

Renault: R 4 T 1. (Fr 33,632).

Talbot: light van 100 VF 2 and VF 3 (Fr 5,791).

There are, on the other hand, personalized kits marketed by Motor Gaz, for all French vehicles and the majority of foreign cars. These kits vary essentially with regard to the throttle chamber and the carburetor and consist of a Century carburetor and all necessary connections for adapting this motor-combustion equipment.

Motor-Gaz, one of the main distributors in France, offers these kits at a price ranging from Fr 4,000-5,000.

TRANSPORTATION

ATR 42 WILL HAVE ULTRAMODERN, INNOVATIVE COCKPIT, AVIONICS

Paris AVIATION MAGAZINE INTERNATIONAL in French 1 Nov 82 pp 38-39

[Article by Serge Brosselin: "First Flight Planned for September 1984"]

As one learns from reading the preceding document, the idea of regional aviation has considerably broadened, if only in the area of its capacities. It is not less evident that above and beyond the special operational needs, the 20- to 30-seat categories on one hand and the 40- to 60-seat categories on the other hand correspond to distinct and clearly defined commercial needs. It is the latter category which the ATR-42 is planned for, an ambitious operation envisioning a vast and promising potential market, and, what is more, brought forth by two builders who have considerable resources.

After having worked at preliminary projects on a strictly national level (the AS-35 in France and the AIT-230 in Italy), it was in mid-1980 that Aerospatiale and Aeritalia noticed that their concepts of future regional aviation were extremely similar. A little later the two companies signed an agreement and enlarged the dialogue with no less than 110 cargo network and regional carriers, a prelude to the establishment, in the first weeks of 1981, of a common project, the ATR-42.

Since then, several decisive steps have been taken: the choice of the Pratt and Whitney PW 120 motor with 1,800 horsepower at takeoff, signatures on several contracts for options and intentions to purchase first, and then firm orders (45 orders have been placed at present, and, last February, the formation of an economic interest group called "Regional Transport Aircraft," with headquarters in Toulouse.

This aircraft, already described in our publication (see AVIMAG 824 of 15 April 1982), with a maximum mass at takeoff of 14,900 kg will incorporate in its basic version a payload of 5 tons, corresponding to 42 passengers and their baggage, and will cruise at 511 kilometers per hour. It will later be introduced in a longer version, the ATR-42-200, with 49 seats, all-cargo variations, and convertible passenger or freight versions, and, later, as the ATR-XX with a somewhat larger capacity. Besides this, Aeritalia is

especially interested in identifying a military market, which did not, however, play a determining role in the general concept of the machine.

The first ATR-52 will leave the factory in July 1984, will be flight tested in September of the same year, and will obtain its flight readiness certificate during the third trimester of 1985. The fabrication of the flight surfaces will be the responsibility of the Naples factory of Aeritalia, the fuselage will be produced at Saint-Nazaire, and the cockpit layout, the installation of the engines, and the final assembly will be accomplished at Toulouse.

Avionics: Innovation in the Service of Safety

But in the commuter aircraft market, it is assuredly in the domain of avionic systems design that the arrival of the ATR-42 will open a new era. Of course it is only logical for the other manufacturers to envision moving, in time, into the market thus opened up by Aerospatiale and Aeritalia, but it will always be remembered that two companies were the precursors; they had the courage to introduce modern technical solutions, and even innovations on a grand scale--with this particular type of aircraft--because the choice taken in favor of introducing a bidirectional multiplexed bus with digital linkage which increases the applications for civil aviation--a revolutionary concept, we must emphasize--was certainly not an easy choice to make. From now on what is certain is that it will probably be very hard to go backward.

From the time of the establishment of the project, the objective was clearly formulated in favor of a digital avionic system. It was the American firm of Sperry, ahead of all of the other competitors (SFENA and Thompson-CSF, and especially Collins) that was finally chosen. Such a choice couldn't, after all, be felt by GIE "ATR" as a handicap, since, commercially speaking, it couldn't help but facilitate the penetration of the American market. But before going further into the heart of this avionic system and the resolute designing of new systems, it would be useful to review certain detailed characteristics of the project plans.

First, speaking of the arrangement of the cockpit of the ATR-42, it is a good idea to recall that the choices made for motion efficiency reflect an identical approach to that which was used for the construction of the Airbus cockpit. We can point out the stress placed by Aerospatiale in that area by the fact that the spacing between the control columns is 1,060 mm on the Airbus and 990 mm on the ATR-42, a figure which, taking into account the size difference between the two aircraft, brings out clearly to what point the desire to optimize the arrangement of the cockpit for crew comfort was taken into consideration from the beginning. The correct technical solutions for improving the passengers' comfort were necessarily also studied very closely. It is thus that, taking into account the operational altitude of the aircraft (cruising ceiling 7,620 m) and the turbulence that it is likely to encounter (more than at 10,000 or 11,000 meters), a wind gust detector will be installed as basic equipment. Generalized Active Control therefore imposes itself as one of the technical solutions which couldn't reasonably be left out. And that is one good place where credit must be given to the

research department of Aerospatiale when one learns the sensitivity with which cantilever wings can indicate that the aircraft is traversing a vertical shear zone. It is in the area of new generation digital equipment, developed by the Sperry avionics division--the digital flight control systems (DAFCS)--that the avionics of the ATR-42 were conceived. We notice in passing that, in the long term, Aerospatiale is planning to offer an FMS (flight management system) as an option on the ATR-42.

But in the immediate future the aircraft's equipment will be as follows: the cathodic visual displays in color proposed as an option for the ATR-42 contain four EFIS (Electronic Flight Instrument System) tubes consisting of two EADI's and two EHSI's on the left side; and, on the right side, a Primus 8000 color radar as well as a screen designed to show the functional modes of the automatic pilot. Let us remember, however, that the basic version of the ATR-42 is proposed with classic electromechanical equipment, the aircraft having been designed, however, with the possibility of being retrofitted with electronic display tubes. In other words, in aircraft fitted with EFIS tubes the MTO radar images are displayed on the EHSI screen, whereas in cockpits fitted with electromechanical instruments, the MTO situation is of course still read on the traditional screen, the screen which is associated with the radar operational mode control box.

One quickly notices, by studying the construction of the system developed by Sperry, that the integration problems and the search for solutions leading to a reduction of the work load on the equipment have been the object of serious research.

In this system, the ASCB multiplexed digital bus is the essential element through which the interconnections with the different instruments and receptors is effected.

This interconnection permits, for example, the transmission of the information furnished by the correctly functioning equipment to another generator, in case of the failure of one of the digital symbol generators of the EFIS visual displays. In the same manner, if an inherent failure takes place simultaneously in the tube itself in the EADI and the EHSI, the digital bus authorizes a reconfiguration of the information, so that the information, in all possible problem situations, can be read out at the left as well as at the right seat. This redundancy aspect, which assures the security of the system, is also found in the interconnections that the line bus allows between the other receptors of the DAFCS. For example, in case of a failure of one of the two AHRS, "strap down" type, digital data systems for course or for vertical flight attitude, or of one of the two aerodynamic data systems integrated with the ASCB, the operational redundancy of the assembly is in any case assured by information transfer furnished by the operational equipment.

Finally, two supplementary possibilities offered by the DAFCS provide evidence that in the minds of the Sperry technicians, from the beginning, the concept of an evolving system design was uppermost. At the beginning the DAFCS could be coupled with a surface navigational system (the EHSI, displaying the route by use of a cartographic mode). The possibility of adding an interface to it for the possible future addition of an M.L.S. was taken into account.

PHOTO CAPTIONS

1. p 38. Mockup of the ATR-42. The performance data for the aircraft are as follows. On one motor (at 97 percent of the maximum mass and an ISA of +10 C). Ceiling: 4,085 m. Takeoff distance at sea level: 950 m, and at 3000 ft, with an ISA of +10, 1,150 meters. Landing run: 910 meters.
2. p 39. Drawing 3. Views of the ATR-42. Absolute length: 22.59 m; wing span: 24.37 m; wing surface 54 m²; wing aspect ratio: 11. Time, start to finish, for a flight of 185 km: 32 min. Fuel consumption for that distance: 273 kg.

Boxed Information

ATR-42: The Principal Sources of Equipment

Propellers: Hamilton Standard

Landing gear: Messier-Hispano

Air conditioning: Garret

Electrical generation: Auxilec

Pressurization: Softair (the regulator is digital)

Brakes and wheels: Goodyear

Fuel system: Bronzavia

De-icing system: Kleber-Colombes

Radio communication: King (Gold Crown III)

Hydraulic unit for flap control, and trim control switches for altitude and roll control: SAAM

12230

CSO: 3698/77

TRANSPORTATION

FIAT RESEARCHERS STUDY CERAMICS APPLICATIONS IN DIESELS

Turin ATA--INGEGNERIA AUTOMOTORISTICA in Italian Sep 82 pp 675-679

[Article by A. Giachello, S. Guerra and P.C. Martinengo*: "Use of Silicon-Nitride Ceramics for Automotive-Engine Applications"]

[Excerpts] Introduction

It is known that the use of engineered ceramic materials can considerably improve the efficiency of internal-combustion engines by minimizing the heat losses and recovering mechanical energy from the exhaust gases (1, 2, 3). In particular, such materials' resistance to high temperatures, low coefficient of expansion and very low heat conductivity constitute the basis for development of partially or totally ceramicized engines running in high heat cycles.

From this angle, sintered silicon nitride has a fundamental role, inasmuch as:

--it combines the greatest number of characteristics required for applications of this type;

--it is obtained from raw materials that are not strategic and are very moderate in cost (silicon and nitrogen);

--it is "formable" by industrial processes in common use in the area of sintered materials (cold isostatic pressing) and plastics (injection molding).

The principal automotive and ceramics industries, with Ford and the Japanese in the lead, have undertaken many research projects on this type of material, directed toward development of the material and its application in automotive components (4, 5).

The engines on which greatest interest has been centered and where the most concrete possibilities of success are perceived are the diesel engines in both the traditional and turbocompressor versions, not to overlook the latest possibility of making systems that are adiabatic and lubrication-free.

Figure 1 shows the components that theoretically can be "ceramicized" in a turbocompressed version of a diesel.

* A. Giachello, S. Guerra and P.C. Martinengo of the FIAT SpA Research Center, Metallurgical Technologies.

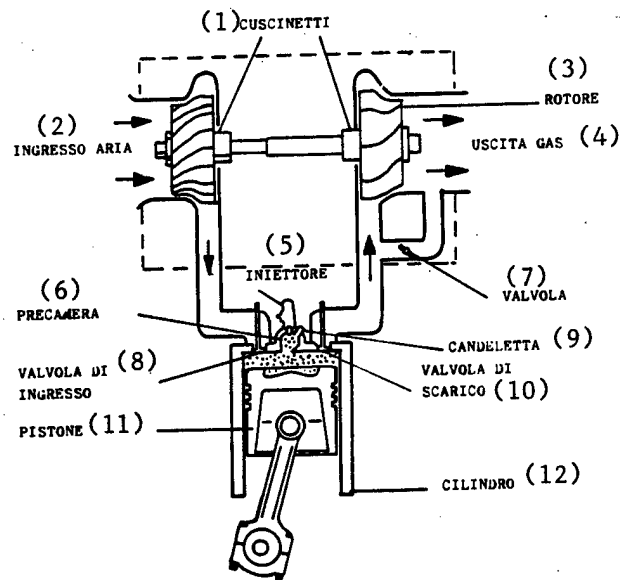

Figure 1. Diesel-engine components that could be made with ceramic material

Key:

- | | |
|--------------------------|-------------------|
| 1. Bearings | 7. Valve |
| 2. Air intake | 8. Intake valve |
| 3. Rotor | 9. Glow plug |
| 4. Gas exhaust | 10. Exhaust valve |
| 5. Injector | 11. Piston |
| 6. Precombustion chamber | 12. Cylinder |

The FIAT Research Center (CRF) has also done work in this area, developing and patenting (6, 7, 8) different types of silicon-nitride-based sintered materials that meet the requirements for engine applications and with which some of the diesel-engine components shown in the diagram have been made.

Materials and Processes

Essentially two types of sintered silicon nitride have been developed by the CRF under the basic condition of making materials with high-grade mechanical properties obtainable by mass-production processes: one obtained from silicon dusts, and the other from silicon-nitride dusts.

The most immediate observation made from the whole of the values resulting is that both materials have a density very close to the theoretical one and are substantially similar, even though, in the case of the sintered material obtained from silicon, the mechanical resistance can prove significantly higher.

Overall, their properties can be considered very close to those of hot-pressed silicon nitride, which constitutes the generic reference-point for identifying the maximum properties obtainable from a sintered ceramic.

The important differences between the two products, apart from the abovementioned one of mechanical strength, are to be attributed to the preparation processes, as can be deduced from Figure 2.

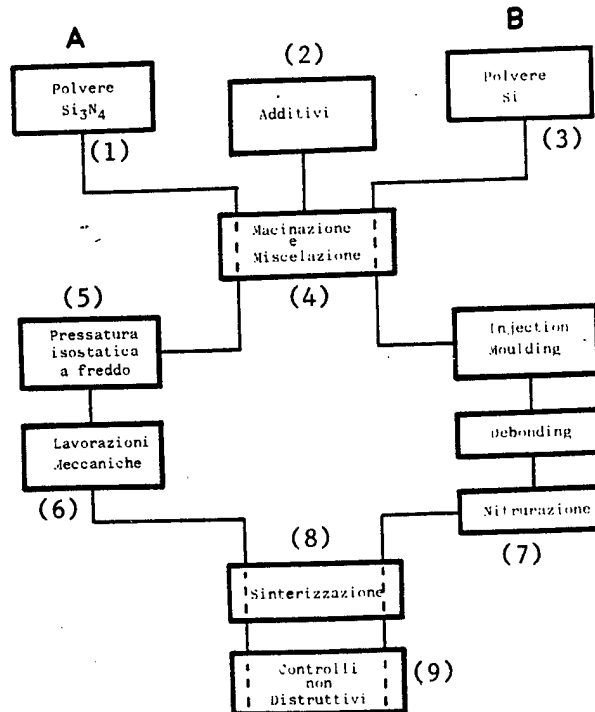

Figure 2. Diagram of preparation processes, starting from Si_3N_4 dust or Si dust

Key:

- | | |
|---------------------------------|---------------------------|
| 1. Si_3N_4 dust | 6. Mechanical washings |
| 2. Additives | 7. Nitriding |
| 3. Si dust | 8. Sintering |
| 4. Crushing and mixing | 9. Nondestructive testing |
| 5. Cold isostatic pressing | |

The nitriding heat treatment that occurs only in the sequence relative to production of sintered material from silicon dusts constitutes the substantial difference between the two processes, as well as the critical part of the entire cycle in both technical and economic terms.

However, the greater cost of the process because of the nitriding heat treatment is amply compensated for, not so much by the elimination of machine working as by the substantial difference in the cost of the powders started with—the difference being of a different order of magnitude as regards silicon nitride (Si_3N_4 costs around Lit 50,000 per kg; Si is around Lit 5,000 per kg).

It follows from this that a technological choice for mass production of components should be oriented toward cycle B at this time; the situation could be reversed by development of a low-cost process for preparation of nitride pow-

ders, for the achievement of which the CRF has already obtained positive indications and which Japanese and English experts are working on also (9).

Making of Engine Components

The principal diesel-engine components that have been made so far with the raw materials indicated are precombustion chambers, ceramic-insert pistons and glow plugs.

Preliminary indications have also been obtained for other parts indicated in the initial scheme as as potentially "ceramicizable," but the results relative to them are to be considered solely at the level of component feasibility.

Precombustion chambers

Precombustion chambers are the type of component that one approaches most readily in analysis of the possibilities of use of special ceramics in engine applications. This is both on account of their particular conditions of use and because of the relative ease of practical fabrication by comparison with other components that operate at high temperature.

The combustion chambers that were considered are those of the Diesel 2000 and 2500 engines (SOFIM [expansion unknown]) for the Ritmo and the 127. In the case of 1700, 2000 and 2500 engines, the changeover to silicon nitride involved part of the chamber presently made with precision-cast Nimocast (precombustion-chamber plug), which constitutes the hottest part of the combustion zone, while in the case of the 1300 engine, the entire precombustion chamber was made with sintered silicon nitride.

This solution was indeed the one most suitable for complete judgment of the technical benefits obtainable from the use of ceramic, but it is also the one most difficult to carry out. The various components made are represented in Figure 3.

Whereas hundreds of hours of tests, as regards the precombustion-chamber plugs, were carried out on engines on the test bench, in the various versions, the functional evaluations for the complete precombustion chamber have still not been made.

In any case, the results so far obtained under different operating conditions have made it possible to note that:

- the thermal and mechanical operating stresses do not generate notable alterations in the ceramic material;
- operating differences in comparison with the tests carried out with the precombustion chambers made of normal-production nickel-based super-alloy are not encountered.

Since the process diagrammed in Figure 2 as "B" makes it possible to hypothesize a precombustion-chamber plug cost lower than that of the present approaches, the preceding indications take on a particular aspect and enable one

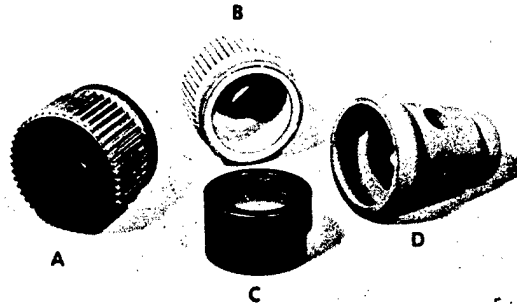

Figure 3. Different types of precombustion chamber made of sintered Si_3N_4 :
A) SOFIM 2500; B) SOFIM 2000; C) Ritmo; D) 127.

to propose the use of sintered silicon nitride not as a method for improving the efficiency of the engine but only as an economically valid alternative to the super-alloy in use.

In any case, the hypothesis of technical benefits is still interesting but remains to be verified on a completely ceramicized chamber, of which the 127 represents a significant example.

Insert-Type Pistons

The primary purpose of the adoption of silicon nitride as an insert in pistons for reciprocating engines is insulation of the piston's material from the high temperatures generated in the combustion chamber, thus making it possible to achieve higher heat regimes--for example, in supercharged engines and in direct-injection diesel engines.

However, the substantial difference between the coefficients of expansion of the two materials, metal and ceramic, makes it difficult to achieve a joining by which detachment of the ceramic insert from its seat in the piston during operation can be avoided. It follows from this that evaluation of the performance characteristics of ceramicized pistons that are not of integral mode depends on development of adequate design and technological solutions that make it possible for them to be fabricated and to survive under the operating conditions envisioned.

The development work done took into consideration pistons for direct-injection diesel engines in which, practically speaking, only the part corresponding to the combustion chamber was ceramicized.

By this solution, the ceramic insert is kept adhering to the piston crown by means of an appropriately preloaded super-alloy spring which in turn is kept in place by an aluminum ring.

An approach of this type obviously does not represent any concrete production possibilities but does constitute a working hypothesis from which to begin experimentation with this type of piston. In this regard, casting-assembly solutions theoretically compatible with production processes, in which the different coefficients of heat expansion of nitride and aluminum are compensated for not only by springs but also by fasteners appropriately designed and inserted directly into the shell were worked out and analyzed experimentally.

Figure 5 [not reproduced] shows pistons made with sintered-Si₃N₄ inserts of type "A," per the preceding diagram, and Figure 6 [not reproduced] shows the cross-section of a piston of the same type in which the insert was incorporated directly at the moment of casting of the piston.

Pistons of the model indicated and ones similar but of smaller dimensions have been subjected to preliminary bench tests in 4-cylinder engines under various stress conditions for a total of about 18 hours of operation.

In both versions made, the tests were interrupted at 3,500-4,000 RPM and under heavy load conditions by detachment of one of the ceramic inserts from its seat, thus showing the necessity of fuller development of the method of insertion of the insert in the piston, and at the same time, the sufficient thermal and mechanical strength of sintered nitride under the operating conditions considered.

Glow Plugs

Diesel-engine glow plugs are certainly components that have less impact on the engine than precombustion chambers and pistons, discussed above; but they do constitute a further interesting possibility of application of silicon nitride.

The coated resistor that constitutes the core of the plug is currently made with nickel-base super-alloy and presents problems of corrosion resistance under the operating conditions (about 1,050 °C) in which it functions. A characteristic of silicon nitride that can be exploited in this case is its unalterability in oxidizing atmospheres and in the presence of combustion gases, even at very high temperatures (1,200 °C). For this specific application, this property must be combined with high insulating power, from the electrical point of view, and good resistance to the thermal and mechanical stresses present in the component in operation.

Since these conditions were theoretically compatible with the types of sintered nitride described at the beginning, prototypes of glow plug were made per the design shown in Figure 7. This project represents only a demonstration of com-

ponent feasibility with a casing of ceramic material and does not indicate the most appropriate solution, from either the manufacturing or performance-characteristics point of view.

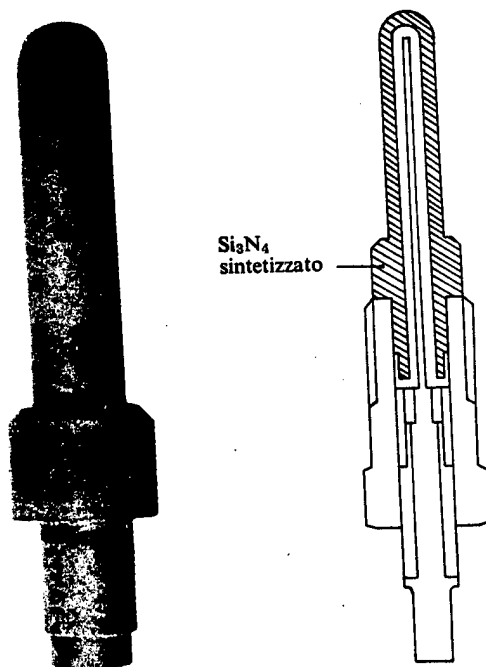

Figure 7. Prototype of glow plug for diesel engine

Key: Synthesized Si₃N₄

In any case, preliminary experimentation with this model has led to a positive judgment about the possibilities of use of silicon nitride for this specific application, and appropriate development is in progress.

Conclusions

Use of silicon nitride in engine components can now be considered possible; the development of specific solutions of this type is a result of the particular properties of this ceramic material, but especially of the acquired availability of production processes for sintered components of low cost and with high performance characteristics.

Precombustion chambers and glow plugs for conventional diesel engines made with sintered silicon nitride are approaches that can be envisioned today. Ceramized pistons, adiabatic engines and ceramic turbines are examples of the evolution in the use of this special ceramic material in the transportation field.

BIBLIOGRAPHY

1. Godfrey, D.J., "The Use of Ceramics in Engines," PROC BRIT CER SOC, No 26, July 1978.
2. McLaughlin, D., "Ceramic Applications in Diesel Engines," PROC BRIT CER SOC, No 26, July 1978.
3. Kamo, R., Woods, M.E. and Geary, W.C., "Ceramics for Adiabatic Diesel Engine," in ENERGY AND CERAMICS, ed by Vincenzini, Elsevier, 1980.
4. Mangels, J.A. and Tennenhouse, G.J., "Densification of Reaction Bonded Silicon Nitride," AM CERAMIC BULLETIN, Vol 59, No 12, 1980.
5. Inaba, M., "Diesel Engine with Ceramic Parts Is Tested in Auto," AM MET MARKET METALWORKING NEWS, February 1982.
6. Giachello, A., Martinengo, P.C. and Tommasini, G., "Sintering of Silicon Nitride in Powder Bed," JOURNAL OF MATERIAL SCIENCE, 14 (1979, pp 2825-2830.
7. Giachello, A., Martinengo, P.C., Tommasini, G. and Popper, P., "Sintering and Properties of Silicon Nitride Containing Y_2O_3 and MgO ," CERAMIC BULLETIN, Vol 59, No 12, 1980.
8. Martinengo, P.C., Giachello, A., Tommasini, G. and Pooper, P., "Process for Sintering Reaction Bonded Silicon Nitride," UK Pat Appl 2010915A, 5 July 1979.
9. Sweda, A., Hendry, A. and Jack, K.H., "The Preparation of Si_3N_4 from Silica by Sol-Gel Processing," PROC OF THE 7TH SYMP OF SPEC CER, The British Ceramic Society, December 1980.

11267
CSO: 3698/100

END